

(21) Application No: 1500445.0  
(22) Date of Filing: 27.06.2013  
Date Lodged: 12.01.2015  
(30) Priority Data:  
(31) 1256798 (32) 13.07.2012 (33) FR  
(86) International Application Data:  
PCT/FR2013/051511 Fr 27.06.2013  
(87) International Publication Data:  
WO2014/009626 Fr 16.01.2014

(51) INT CL:  
B60J 10/08 (2006.01) B60J 10/00 (2006.01)  
B62D 25/07 (2006.01)  
(56) Documents Cited:  
DE 003614506 A1 FR 002094969 A5  
JPS5871265  
(58) Field of Search:  
INT CL B60J, B60R, B61D, B61D, B62D, E06B  
Other: EPO-Internal

(71) Applicant(s):  
Faiveley Transport  
3 rue du 19 mars 1962, GENNEVILLIERS, 92230,  
France (including Overseas Departments and Territories)  
(72) Inventor(s):  
Christophe Proust  
Bruno Salins  
(74) Agent and/or Address for Service:  
Novagraaf UK  
2nd Floor Renown House, 33-34 Bury Street,  
LONDON, EC3A 5AR, United Kingdom

(54) Title of the Invention: Device for sealing an outer door wing of a railroad vehicle  
Abstract Title: Device for sealing an outer door wing of a railroad vehicle

(57) The invention relates to a device for sealing an outer door wing (2) of a railroad vehicle, including a frame (3) of the vehicle, a wing (2) extending longitudinally and movably mounted relative to the frame (3), a longitudinal body (4) for protecting an upper inner space (5) located between an upper portion of the wing (2) and the vehicle frame (3), said longitudinal protection body (4) being secured to the wing (2), the device (1) having a longitudinal space (8) for passing between an upper portion (6) of the longitudinal protection body (4) and the frame (3) of the vehicle, a first longitudinal channel (9a) for discharging water outside of the wing (2) and at least one second longitudinal channel (9b,9c) for discharging water outside of the wing (2).

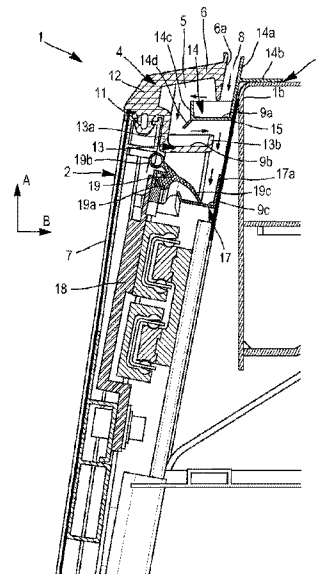

FIG. 1