



US 20140008695A1

(19) **United States**

(12) **Patent Application Publication**
KOBAYAKAWA

(10) **Pub. No.: US 2014/0008695 A1**

(43) **Pub. Date: Jan. 9, 2014**

(54) **SEMICONDUCTOR LIGHT-EMITTING DEVICE**

(30) **Foreign Application Priority Data**

(71) Applicant: **ROHM CO., LTD.**, Kyoto-shi (JP)

Mar. 30, 2007 (JP) JP2007-092879

(72) Inventor: **Masahiko KOBAYAKAWA**, Kyoto-shi (JP)

Publication Classification

(73) Assignee: **ROHM CO., LTD.**, Kyoto-shi (JP)

(51) **Int. Cl.**
H01L 33/62 (2006.01)

(21) Appl. No.: **14/021,501**

(52) **U.S. Cl.**
CPC **H01L 33/62** (2013.01)
USPC **257/99**

(22) Filed: **Sep. 9, 2013**

(57) **ABSTRACT**

Related U.S. Application Data

(60) Continuation of application No. 13/414,294, filed on Mar. 7, 2012, now Pat. No. 8,541,808, which is a continuation of application No. 12/890,964, filed on Sep. 27, 2010, now Pat. No. 8,154,045, which is a division of application No. 12/079,760, filed on Mar. 28, 2008, now Pat. No. 7,825,426.

A semiconductor light-emitting device includes a lead frame, a semiconductor light-emitting element mounted on the top surface of the bonding region, and a case covering part of the lead frame. The bottom surface of the bonding region is exposed to the outside of the case. The lead frame includes a thin extension extending from the bonding region and having a top surface which is flush with the top surface of the bonding region. The thin extension has a bottom surface which is offset from the bottom surface of the bonding region toward the top surface of the bonding region.

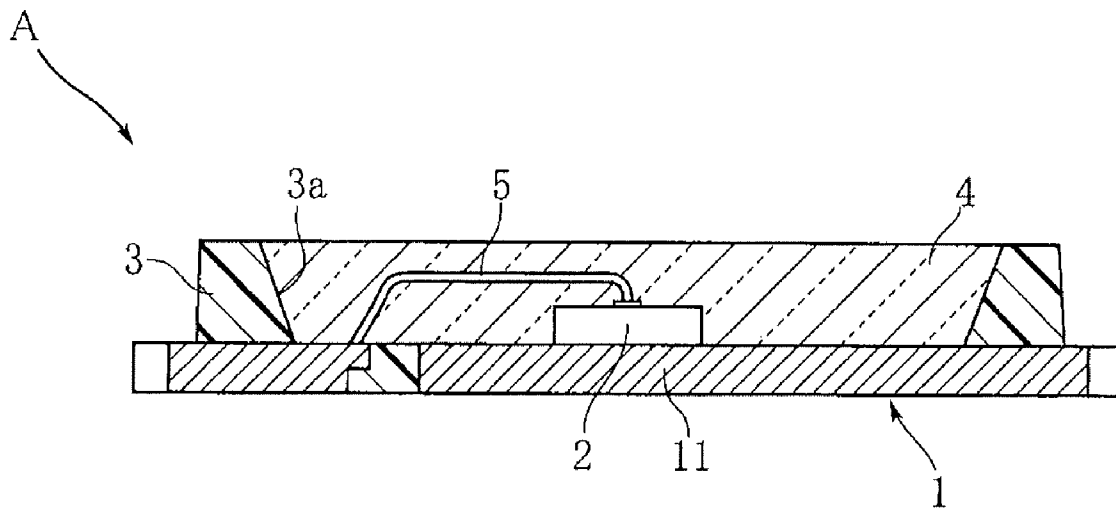

Fig.1

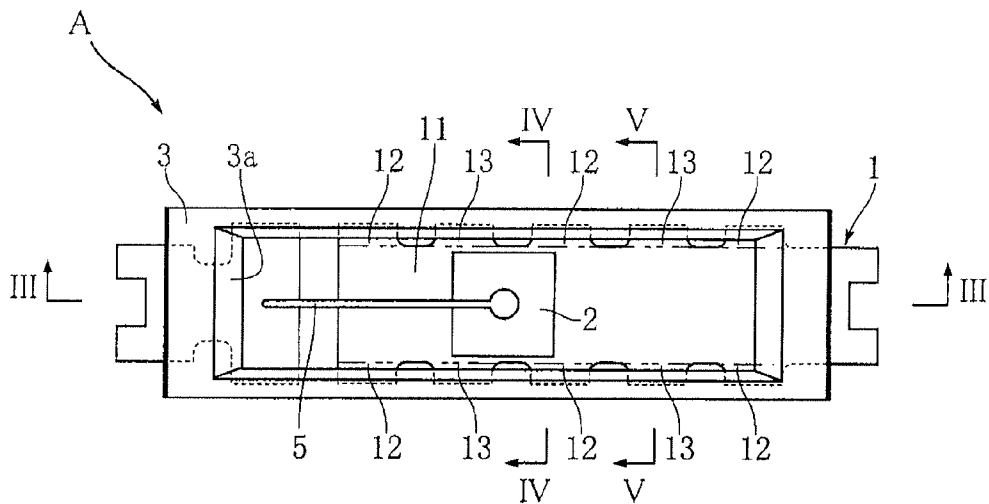
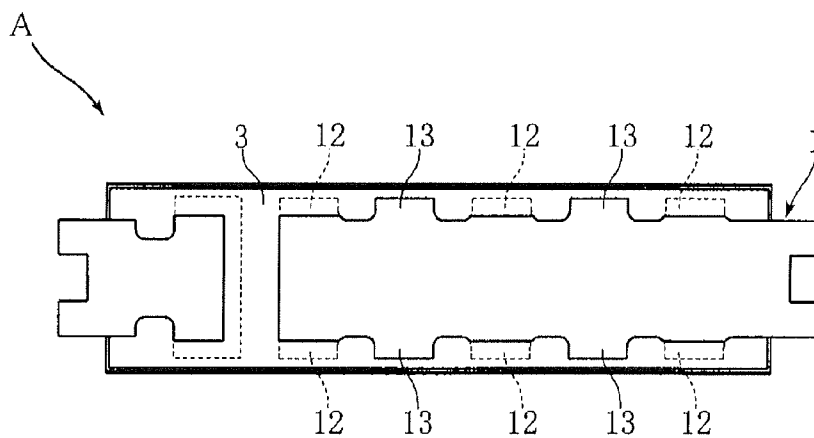

Fig.2



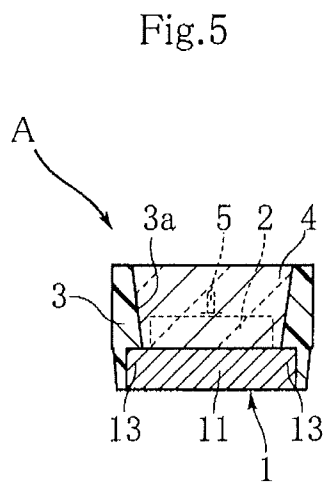
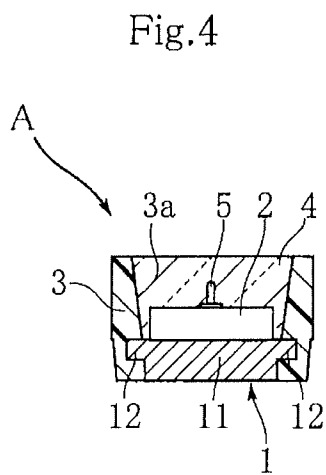
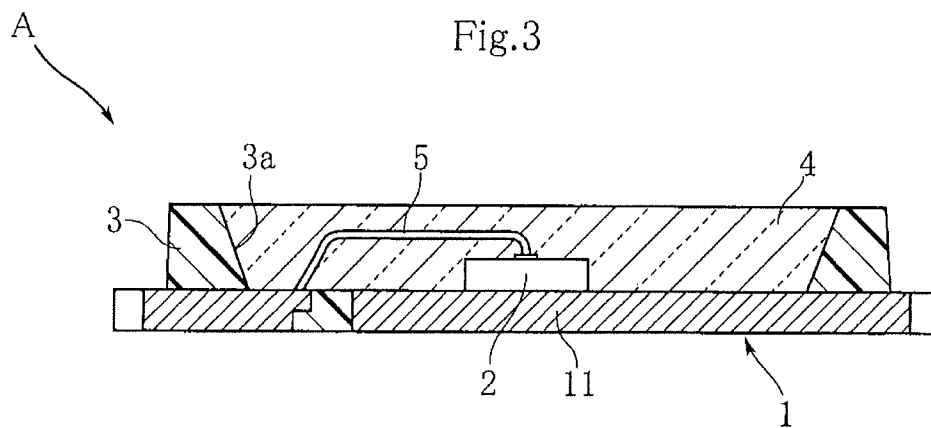

Fig.6

Prior Art

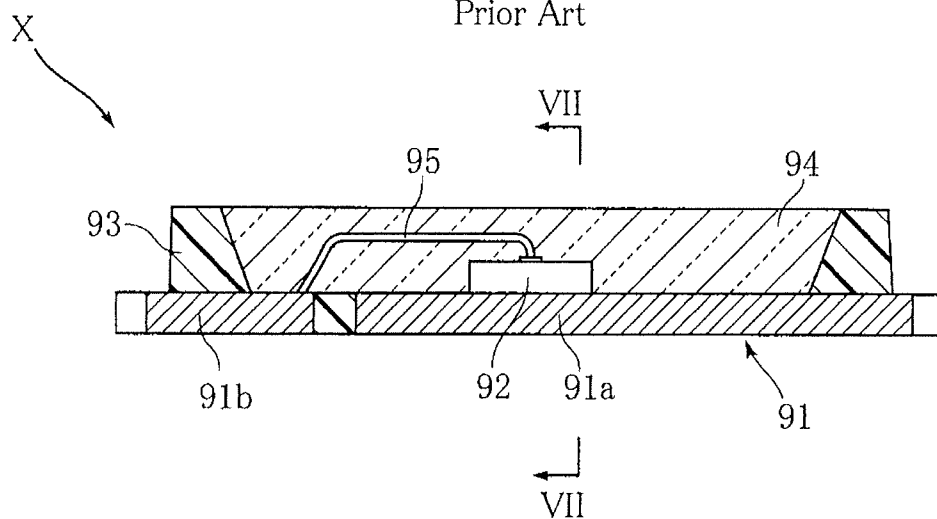
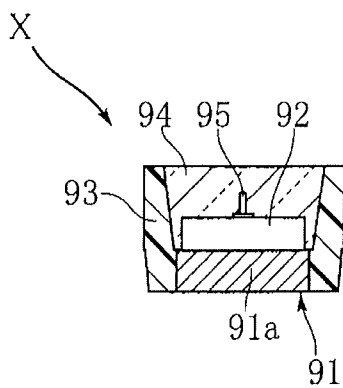

Fig.7

Prior Art



SEMICONDUCTOR LIGHT-EMITTING DEVICE

[0001] This application is a Continuation of application Ser. No. 13/414,294, filed Mar. 7, 2012, which is a Continuation of application Ser. No. 12/890,964, filed Sep. 27, 2010, which is a Division of application Ser. No. 12/079,760, filed Mar. 28, 2008, which applications are incorporated herein by reference.

BACKGROUND OF THE INVENTION

[0002] 1. Field of the Invention

[0003] The present invention relates to a semiconductor light-emitting device provided with a semiconductor light-emitting element.

[0004] 2. Description of the Related Art

[0005] FIGS. 6 and 7 illustrate an example of conventional semiconductor light-emitting device (see JP-A-2005-353914, for example). The illustrated semiconductor light-emitting device X includes a lead frame 91, an LED chip 92, a case 93, and a transparent resin 94. The lead frame 91 includes two strip portions, i.e., a relatively long portion 91a and a relatively short portion 91b, as seen from FIG. 6. These two portions, having the same width as seen from FIG. 7, are fitted into a lower space in the case 93 in a manner such that the bottom surface of the lead frame 91 is exposed out of the case 93. The LED chip 92 serves as a light source of the semiconductor light-emitting device X, and is bonded to the longer strip portion 91a of the lead frame 91. The LED chip 92 is connected to the shorter strip portion 91b of the lead frame 91 via a wire 95. The light-emitting device X may be mounted on a printed circuit board, for example.

[0006] In order to obtain stronger light emission from the semiconductor light-emitting device X, it is required to apply greater electrical power to the LED chip 92. Inevitably, the amount of heat generated by the LED chip 92 is increased, and for maintaining the proper light emission, the heat should be conducted from the longer strip portion 91a to the circuit board. One way to facilitate the heat conduction is to broaden the strip portion 91a (hence the lead frame 91) to which the LED chip 92 is attached.

[0007] While the width of the longer strip portion 91a is to be increased, the overall size of the case 93 may be unchanged so that the light-emitting device X is kept compact. In this case, the side walls of the case 93 need to be made thinner to permit the size increase of the longer strip portion 91a. This configuration, however, will weaken the frame-holding force of the case 93, which may allow the lead frame 91 to drop off from the case 93.

SUMMARY OF THE INVENTION

[0008] The present invention has been proposed under above-described circumstances, and thus an object of the present invention is to provide a semiconductor light-emitting device that is compact and capable of emitting bright light.

[0009] According to the present invention, there is provided a semiconductor light-emitting device comprising: a lead frame including a bonding region having a top surface and a bottom surface; a semiconductor light-emitting element mounted on the top surface of the bonding region; and a case covering part of the lead frame. The bottom surface of the bonding region is exposed to an outside of the case. The lead frame includes a thin extension extending from the bonding region and having a top surface and a bottom surface. The top

surface of the thin extension is flush with the top surface of the bonding region, while the bottom surface of the thin extension is offset from the bottom surface of the bonding region toward the top surface of the bonding region.

[0010] Preferably, the semiconductor light-emitting device of the present invention may further comprise a thick extension extending from the bonding region and having a top surface and a bottom surface. The thick extension is arranged adjacent to the thin extension and is the same in thickness as the bonding region. The bottom surface of the thick extension is exposed to the outside of the case.

[0011] Other features and advantages will be apparent from the following description with reference to the accompanying drawings.

BRIEF DESCRIPTION OF THE DRAWINGS

[0012] FIG. 1 is a plan view illustrating the principal portions of a semiconductor light-emitting device according to the present invention.

[0013] FIG. 2 is a bottom view illustrating the semiconductor light-emitting device shown in FIG. 1.

[0014] FIG. 3 is a sectional view taken along lines III-III in FIG. 1.

[0015] FIG. 4 is a sectional view taken along lines IV-IV in FIG. 1.

[0016] FIG. 5 is a sectional view taken along lines V-V in FIG. 1.

[0017] FIG. 6 is a sectional view illustrating a conventional semiconductor light-emitting device.

[0018] FIG. 7 is a sectional view taken along lines VII-VII in FIG. 6.

DETAILED DESCRIPTION OF THE PREFERRED EMBODIMENTS

[0019] Preferred embodiments of the present invention will be described below with reference to the accompanying drawings.

[0020] FIGS. 1-5 illustrate a semiconductor light-emitting device according to the present invention. The semiconductor light-emitting device A includes a lead frame 1, a light-emitting diode (LED) chip 2, a case 3, and a protection resin 4 that allows the passage of light emitted from the LED chip 2. The light-emitting device A is a small rectangular parallelepiped having a length of about 4 mm, a width of about 1 mm, and a height of about 0.6 mm. In FIG. 1, for convenience of explanation, the protection resin 4 is not shown.

[0021] The lead frame 1 is made of Cu, Ni, or an alloy containing Cu and/or Ni. As shown in FIG. 2, the lead frame 1 is exposed out of the case 3 at its bottom surface, and is divided into a longer primary portion and a shorter secondary portion. The primary portion includes a bonding region 11, a plurality of thin extensions 12, and a plurality of thick extensions 13. In FIG. 1, the boundary between the bonding region 11 and the extensions 12, 13 is indicated by double-dot broken lines.

[0022] The bonding region 11 is a strip-shaped region on part of which the LED chip 2 is mounted. Each of the thin extensions 12 extends out from the bonding region 11, and has a thickness which is about half the thickness of the bonding region 11, for example. As shown in FIG. 4, the top surfaces of the thin extensions 12 are flush with the top surface of the bonding region 11. The bottom surfaces of the thin extensions 12 are positioned higher than the bottom

surface of the bonding portion **11**, as viewed vertically in FIG. **4** (in other words, the bottom surfaces of the thin extensions **12** are offset toward the top surface of the bonding region **11** from the bottom surface of the bonding region **11**). The bottom surfaces of the thin extensions **12** are covered by the case **3**.

[0023] As shown in FIG. **5**, each of the thick extensions **13** extends out from the bonding region **11**, and has a thickness which is substantially the same as the thickness of the bonding region **11**. The top surfaces of the thick extensions **13** are flush with the top surface of the bonding region **11**, and the bottom surfaces of the thick extensions **13** (which are flush with the bottom surface of the bonding region **11**) are exposed to the outside of the case **3**. As shown in FIGS. **1** and **2**, the thin extensions **12** and the thick extensions **13** are arranged alternately in the longitudinal direction of the lead frame **1**.

[0024] The LED chip **2** as a light source of the light-emitting device **A** is configured to emit light of a predetermined wavelength. The LED chip **2** is made of a semiconductor material such as GaN, for example, and emits blue light, green light, or red light by the recombination of electrons and holes at an active layer sandwiched by an n-type semiconductor layer and a p-type semiconductor layer. The LED chip **2** is connected to the shorter portion of the lead frame **1** via a wire **5**.

[0025] The case **3** is made of a white resin, for example, and is a generally rectangular frame. As shown in FIGS. **3-5**, the inner surfaces of the case **3** serve as a reflector **3a** that tapers downward. The reflector **3a** upwardly reflects light which is emitted laterally from the LED chip **2**. As shown in FIG. **4**, the case **3** is held in unreleasable engagement with the thin extensions **12**. Further, as shown in FIG. **2**, the case **3** is in mesh with the thin extensions **12** and the thick extensions **13**.

[0026] The protection resin **4** is made of a transparent or transparent epoxy resin, for example, filled in a space defined by the case **3**. The protection resin **4** covers the LED chip **2**, and while protecting the LED chip **2**.

[0027] Next, the functions of the semiconductor light device **A** will be described below.

[0028] As described above, the case **3** is held in unreleasable engagement with the thin extensions **12**. Thus, the lead frame **1** is reliably held by the case **3**, to be prevented from dropping off from the case **3**. As a result, though the light-emitting device **A** has a very small width (about 1 mm), the lead frame **1** is exposed out of the case **3** in a relatively large area, as seen from FIG. **2**. Therefore, heat can be efficiently conducted from the LED chip **2** to a printed circuit board, for example, which contributes to attaining light emission of desired intensity.

[0029] As described above, the thin extensions **12** and the thick extensions **13** are arranged to alternate with each other, and the bottom surfaces of the thick extensions **13** are exposed to the outside of the case **3**, as shown in FIG. **2**. In this manner, the exposed area of the lead frame **1** can be increased. Advantageously, this facilitates the heat dissipation from the led chip **2**.

1-2. (canceled)

3. A semiconductor device comprising:

- a first lead frame including an upper surface and a lower surface spaced from each other in a thickness direction;
- a semiconductor element mounted on the upper surface of the first lead frame;

- a second lead frame spaced apart from the first lead frame in a first direction, the second lead frame including an upper surface and a lower surface;

- a case covering a part of each of the first lead frame and the second lead frame; and

- a wire connecting an upper surface of the semiconductor element and the upper surface of the second lead frame; wherein the first lead frame includes a first exposed portion provided with an upper surface and a lower surface that is exposed from the case,

- the second lead frame includes a second exposed portion provided with an upper surface and a lower surface that is exposed from the case,

- the first lead frame includes a first thin extension smaller in thickness than the first exposed portion, the first thin extension extending from the first exposed portion in a second direction perpendicular to both the first direction and the thickness direction,

- the second lead frame includes a second thin extension smaller in thickness than the second exposed portion, the second thin extension extending from the second exposed portion in the second direction,

- the first thin extension includes an upper surface and a lower surface, the upper surface of the first thin extension being flush with the upper surface of the first exposed portion, the lower surface of the first thin extension being covered with the case, and

- the second thin extension includes an upper surface and a lower surface, the upper surface of the second thin extension being flush with the upper surface of the second exposed portion, the lower surface of the second thin extension being covered with the case.

4. The semiconductor device according to claim **3**, wherein the first lead frame includes a first end and a second end opposite to the first end, the first end being closer to the second lead frame than the second end is, the first thin extension being disposed at the first end of the first lead frame.

5. The semiconductor device according to claim **3**, wherein the second lead frame includes a first end and a second end opposite to the first end of the second lead frame, the first end of the second lead frame being closer to the first lead frame than the second end of the second lead frame is, the second thin extension being disposed at the first end of the second lead frame.

6. The semiconductor device according to claim **3**, wherein the semiconductor element is mounted on the first exposed portion.

7. The semiconductor device according to claim **3**, wherein the second exposed portion includes a wire bonding region to which the wire is bonded.

8. The semiconductor device according to claim **3**, wherein the second lead frame includes a third thin extension smaller in thickness than the second exposed portion, the third thin extension extending from the second exposed portion in the first direction.

9. The semiconductor device according to claim **8**, wherein the second thin extension and the third thin extension are continuously connected to each other along an edge of the second exposed portion.

10. The semiconductor device according to claim **3**, wherein the first lead frame includes a fourth thin extension smaller in thickness than the first exposed portion and disposed adjacent to the first thin extension, and the first lead frame is formed with a first recess located between the first

thin extension and the fourth thin extension, the first recess being indented in the second direction relative to both the first thin extension and the fourth thin extension.

11. The semiconductor device according to claim **10**, wherein the first lead frame includes a thick extension greater in thickness than both the first thin extension and the fourth thin extension and located between the first thin extension and the fourth thin extension.

12. The semiconductor device according to claim **10**, wherein the first lead frame includes a fifth thin extension smaller in thickness than the first exposed portion and disposed adjacent to the fourth thin extension, and wherein the first thin extension, the fourth thin extension and the fifth thin extension are arranged at same intervals in the first direction.

13. The semiconductor device according to claim **7**, wherein the case covers the second lead frame in a manner such that the wire bonding region is exposed from the case.

14. The semiconductor device according to claim **3**, wherein the second lead frame includes a terminal opposite to the first lead frame and is formed with a second recess located between the terminal and the second thin extension, the second recess being indented in the second direction relative to the second thin extension.

15. The semiconductor device according to claim **10**, wherein the first thin extension and the fourth thin extension are aligned in the first direction.

16. The semiconductor device according to claim **3**, wherein the case includes a bottom surface flush with the lower surface of the first exposed portion.

17. The semiconductor device according to claim **3**, wherein the first thin extension includes an end spaced from the first exposed portion in the second direction and embedded in the case.

18. The semiconductor device according to claim **10**, wherein the first lead frame includes a terminal protruding from the case in the first direction, the first lead frame is formed with an additional recess facing the first recess in the second direction, and a distance between the first recess and the additional recess is equal to a size of the terminal of the first lead frame in the second direction.

19. The semiconductor device according to claim **3**, wherein the lower surface of the first thin extension is parallel to the upper surface of the first exposed portion.

20. The semiconductor device according to claim **3**, wherein the first lead frame includes an upright portion connected to both the lower surface of the first exposed portion and the first thin extension, the upright portion being perpendicular to the upper surface of the first exposed portion.

21. The semiconductor device according to claim **10**, wherein the first lead frame is elongated in the first direction, and the first recess corresponds in position to the semiconductor element in the first direction.

* * * * *