

(12) **United States Patent**
Hopkins

(10) **Patent No.:** US 10,549,907 B2
(45) **Date of Patent:** *Feb. 4, 2020

(54) **PORTABLE CONTAINMENT SYSTEM FOR HAZARDOUS OR OTHER MATERIALS**

(71) Applicant: **TitanLiner, Inc.**, Midland, TX (US)
(72) Inventor: **Joshua D. Hopkins**, Midland, TX (US)
(73) Assignee: **TitanLiner, Inc.**, Midland, TX (US)

(*) Notice: Subject to any disclaimer, the term of this patent is extended or adjusted under 35 U.S.C. 154(b) by 0 days.

This patent is subject to a terminal disclaimer.

(21) Appl. No.: **16/188,810**

(22) Filed: **Nov. 13, 2018**

(65) **Prior Publication Data**
US 2019/0077590 A1 Mar. 14, 2019

Related U.S. Application Data
(63) Continuation of application No. 15/800,614, filed on Nov. 1, 2017, now Pat. No. 10,131,494, which is a (Continued)

(51) **Int. Cl.**
B65D 90/24 (2006.01)
B65D 88/16 (2006.01)
F16N 31/00 (2006.01)

(52) **U.S. Cl.**
CPC **B65D 88/16** (2013.01); **B65D 90/24** (2013.01); **F16N 31/006** (2013.01)

(58) **Field of Classification Search**
CPC B65D 88/16; B65D 90/22; B65D 90/24; F16N 31/006; B08B 17/00; B64D 1/16
(Continued)

(56) **References Cited**

U.S. PATENT DOCUMENTS

3,933,002 A 1/1976 Vickery
5,090,588 A 2/1992 Van Romer et al.
(Continued)

FOREIGN PATENT DOCUMENTS

WO 02/083493 A1 10/2002

OTHER PUBLICATIONS

International Search Report dated Jan. 22, 2013 in connection with International Patent Application No. PCT/US2012/055342, 2 pages.
(Continued)

Primary Examiner — Andrew T Kirsch
Assistant Examiner — Elizabeth J Volz

(57) **ABSTRACT**

An apparatus includes a containment structure having a floor and one or more free-standing flexible walls extending along an outer perimeter of the floor and surrounding a central portion of the floor. The floor includes one or more pieces of fabric, and each free-standing flexible wall includes one or more pieces of shape memory material and extending above the floor. The one or more pieces of shape memory material are attached to the one or more pieces of fabric via a liquid-impervious material applied to the one or more pieces of fabric along the outer perimeter of the floor. The liquid-impervious material is located on the one or more pieces of fabric and the one or more pieces of shape memory material such that the floor and the one or more free-standing flexible walls are liquid-impervious and define a space configured to retain liquid in the containment structure.

20 Claims, 15 Drawing Sheets

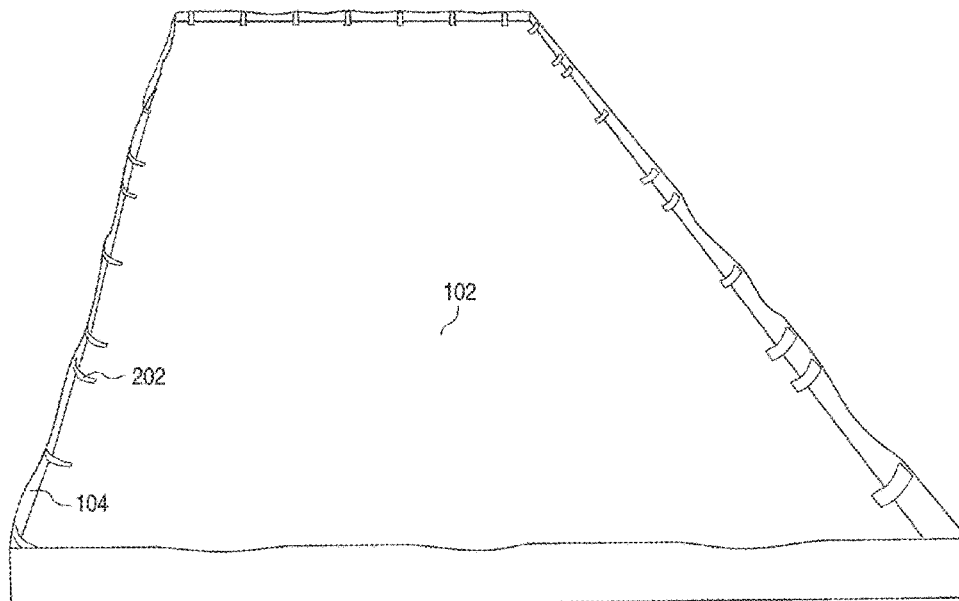

Related U.S. Application Data

continuation of application No. 14/840,863, filed on Aug. 31, 2015, now Pat. No. 9,828,173, which is a continuation of application No. 14/223,425, filed on Mar. 24, 2014, now Pat. No. 9,126,745, which is a continuation-in-part of application No. 13/616,602, filed on Sep. 14, 2012, now Pat. No. 8,998,013.

- (60) Provisional application No. 61/535,760, filed on Sep. 16, 2011.
- (58) **Field of Classification Search**
USPC 220/9.1, 4.12, 9.4, 573, 605; 156/278; 264/257
See application file for complete search history.

- (56) **References Cited**

U.S. PATENT DOCUMENTS

5,464,492	A	11/1995	Gregory et al.	
5,567,259	A	10/1996	Gregory et al.	
5,743,984	A *	4/1998	Gregory	B08B 17/00 156/242
5,762,233	A	6/1998	Van Romer	
5,800,091	A	9/1998	Van Romer	
5,968,814	A	10/1999	Blake et al.	
6,019,243	A	2/2000	Marino	
6,092,686	A	7/2000	Shaw et al.	
6,880,720	B2	4/2005	Van Romer	
7,168,568	B2	1/2007	Van Romer	
7,452,433	B2	11/2008	Shin et al.	
7,736,097	B2	6/2010	D'Andreta et al.	
8,191,722	B1	6/2012	Town	
8,740,006	B2	6/2014	Matson	
9,126,745	B2	9/2015	Hopkins	
9,828,173	B2	11/2017	Hopkins	
2003/0053865	A1 *	3/2003	Ianniello	B09B 1/00 405/129.1

2008/0102242	A1	5/2008	Hamdar et al.	
2008/0223857	A1	9/2008	Palley et al.	
2010/0140262	A1 *	6/2010	Whitener	B65D 90/24 220/4.12
2012/0189810	A1	7/2012	Whitener	

OTHER PUBLICATIONS

Written Opinion of the International Searching Authority dated Jan. 22, 2013 in connection with International Patent Application No. PCT/US2012/055342, 6 pages.
 "Collapsible Wall Spill Berm", Interstate Products, Inc., printed on Apr. 3, 2012, http://www.interstateproducts.com/collapsible_wall_spill_berm.htm, 2 pages.
 "Falcon Equipment Pad, High-Tech Wellsite Protection", Falcon Technologies and Services, Inc., 2012, 2 pages.
 "Flex Wall Spill Berm", Interstate Products, Inc., printed on Apr. 3, 2012, http://interstateproducts.com/flex_wall_spill_berms.htm, 2 pages.
 "Portable Fol-Da-Tank", printed on Apr. 3, 2012; http://www.fol-da-tank.com/page/secondary_containment.aspx, 9 pages.
 "Rain for Rent—SpillGuard Portable Berms" printed from Internet Apr. 3, 2012; [http://www.rainforrent.com/products/Spillguards/spiliguardspro . . .](http://www.rainforrent.com/products/Spillguards/spiliguardspro...), 1 page.
 "Spill Containment Berms", Interstate Products, Inc., printed on Apr. 3, 2012, http://www.interstateproducts.com/spill_berms.htm, 3 pages.
 "Versa-Berm", Versatech Products, Inc., printed on Apr. 3, 2012, <http://versatecg.com/versa-berm.html>, 4 pages.
 Office Action dated Jun. 4, 2014 in connection with U.S. Appl. No. 13/616,602, 11 pages.
 Office Action dated Jan. 14, 2015 in connection with U.S. Appl. No. 14/284,641, 13 pages.
 Office Action dated Apr. 30, 2015 in connection with U.S. Appl. No. 14/284,641, 19 pages.
 Examiner-Initiated Inter view Summary and Advisory Action dated Jul. 1, 2015 in connection with U.S. Appl. No. 14/284,641, 6 pages.

* cited by examiner

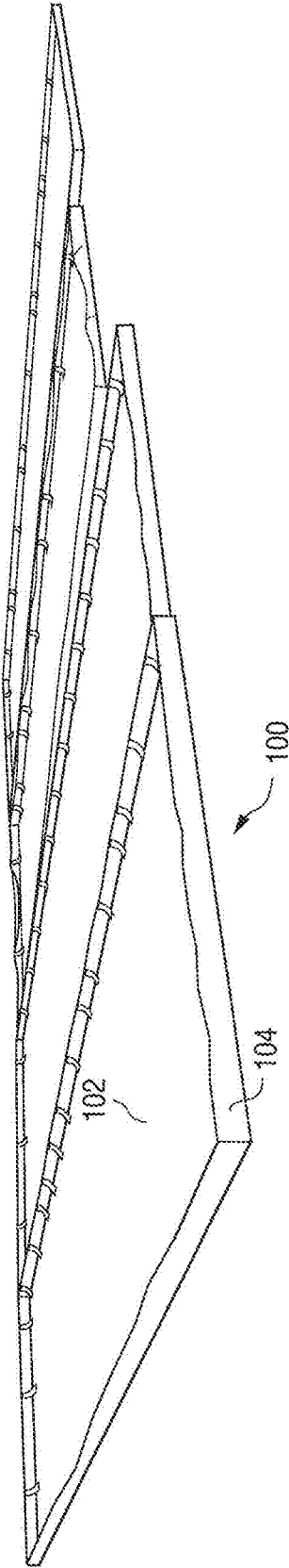

FIG. 1

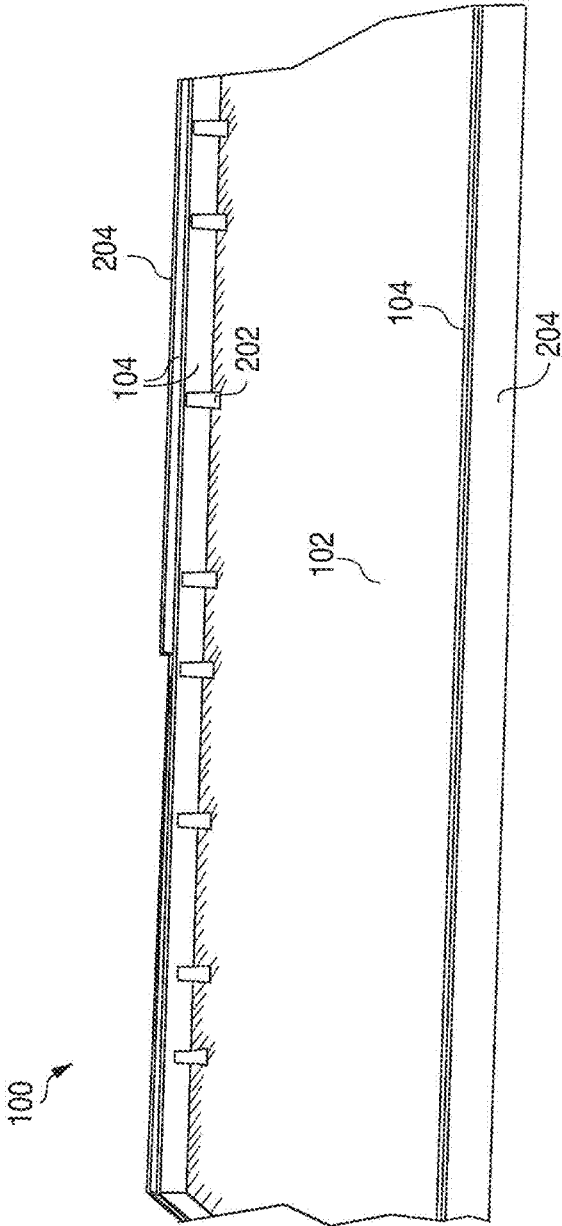

FIG. 2

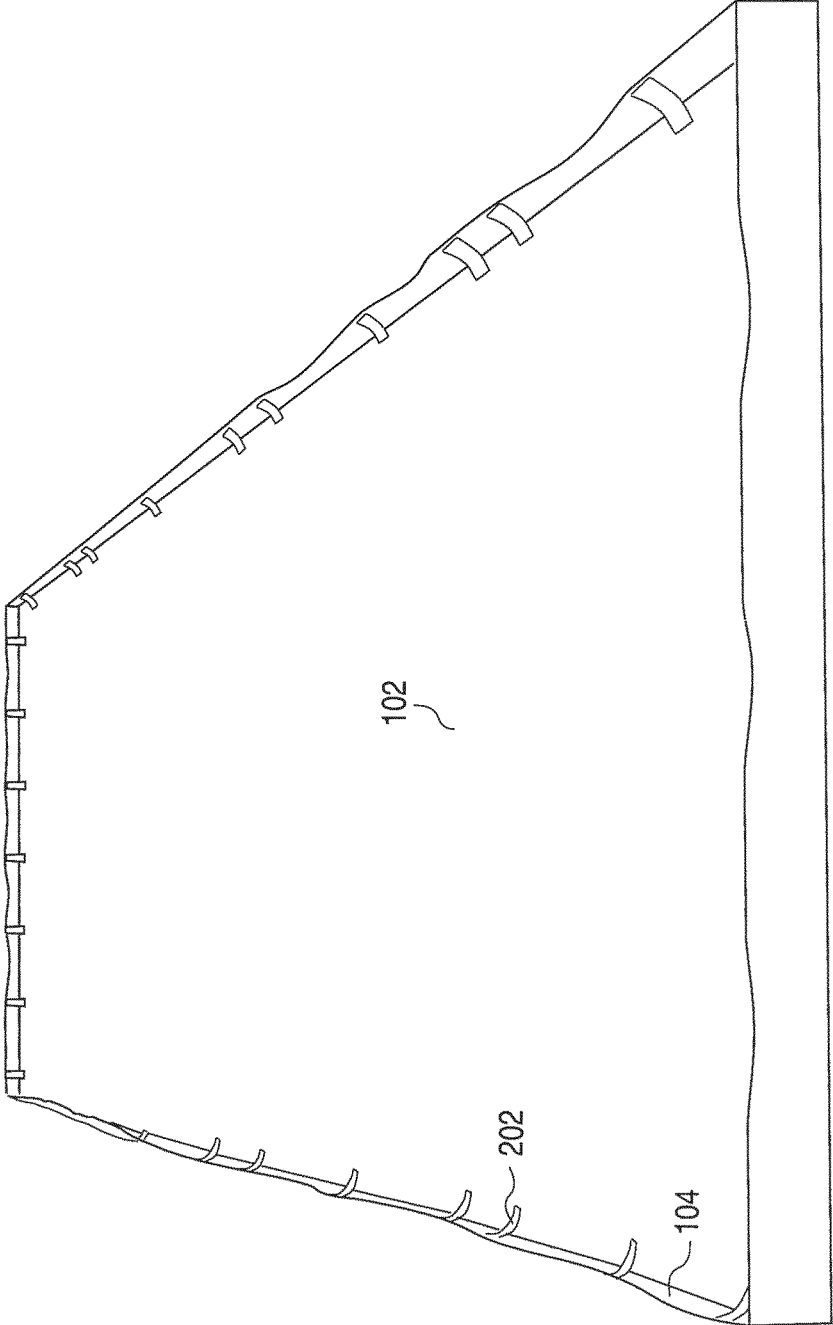

FIG. 3

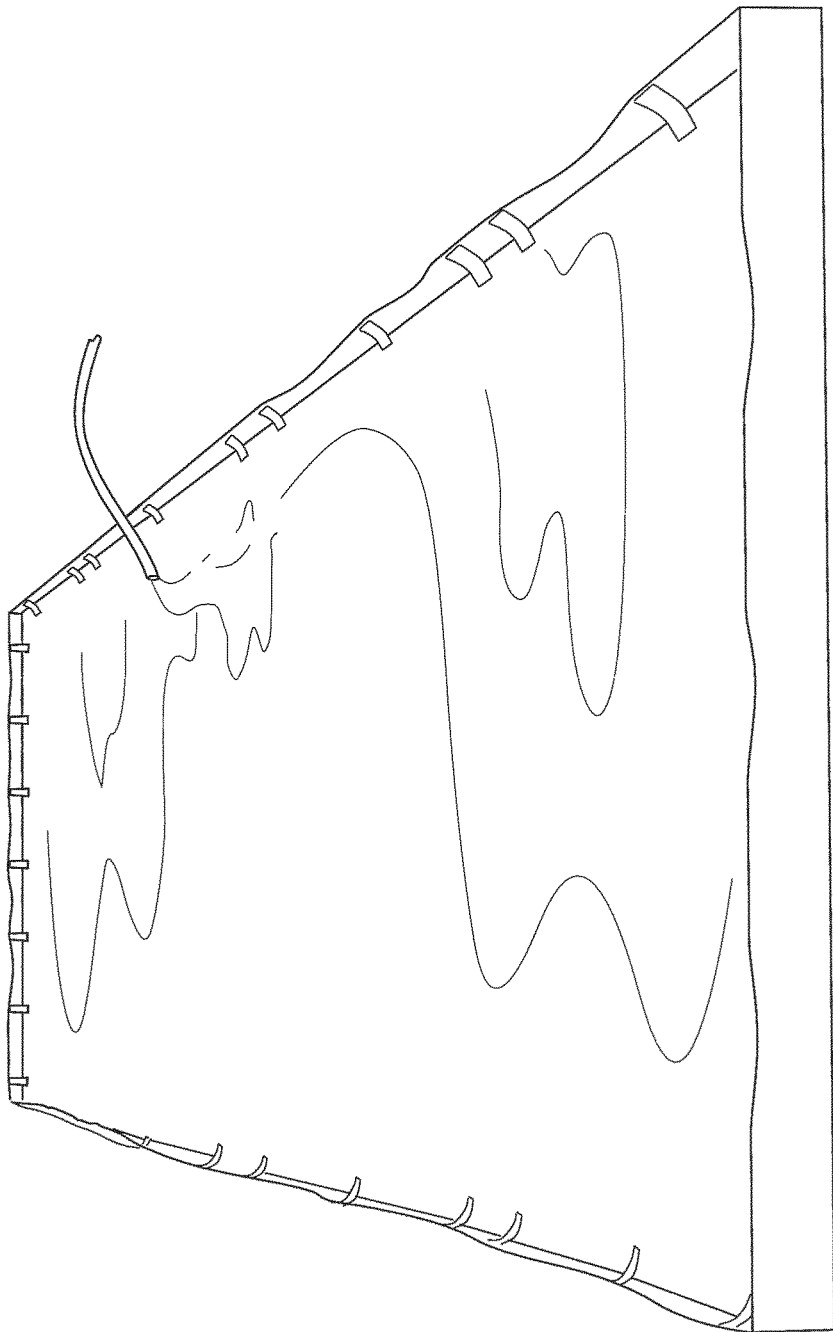

FIG. 4

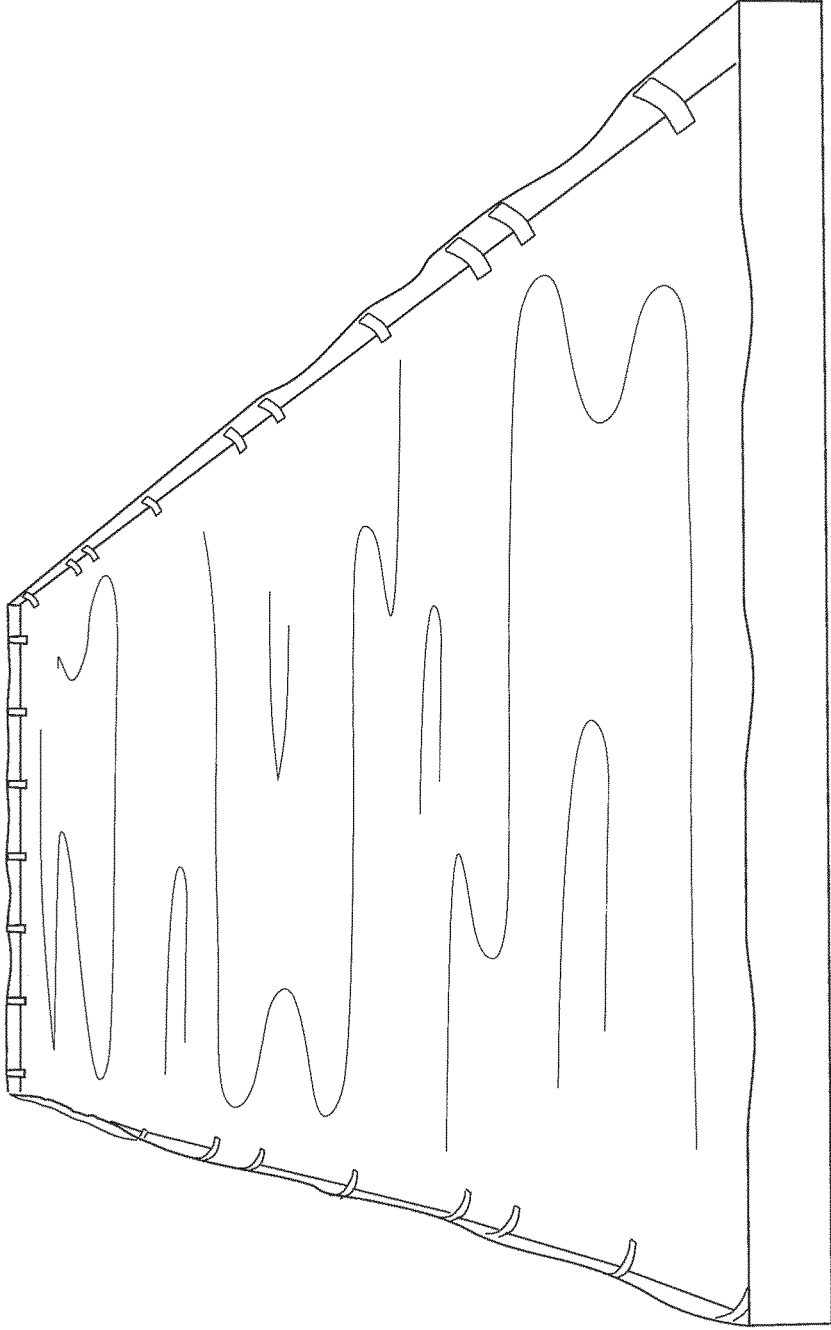

FIG. 5



FIG. 6

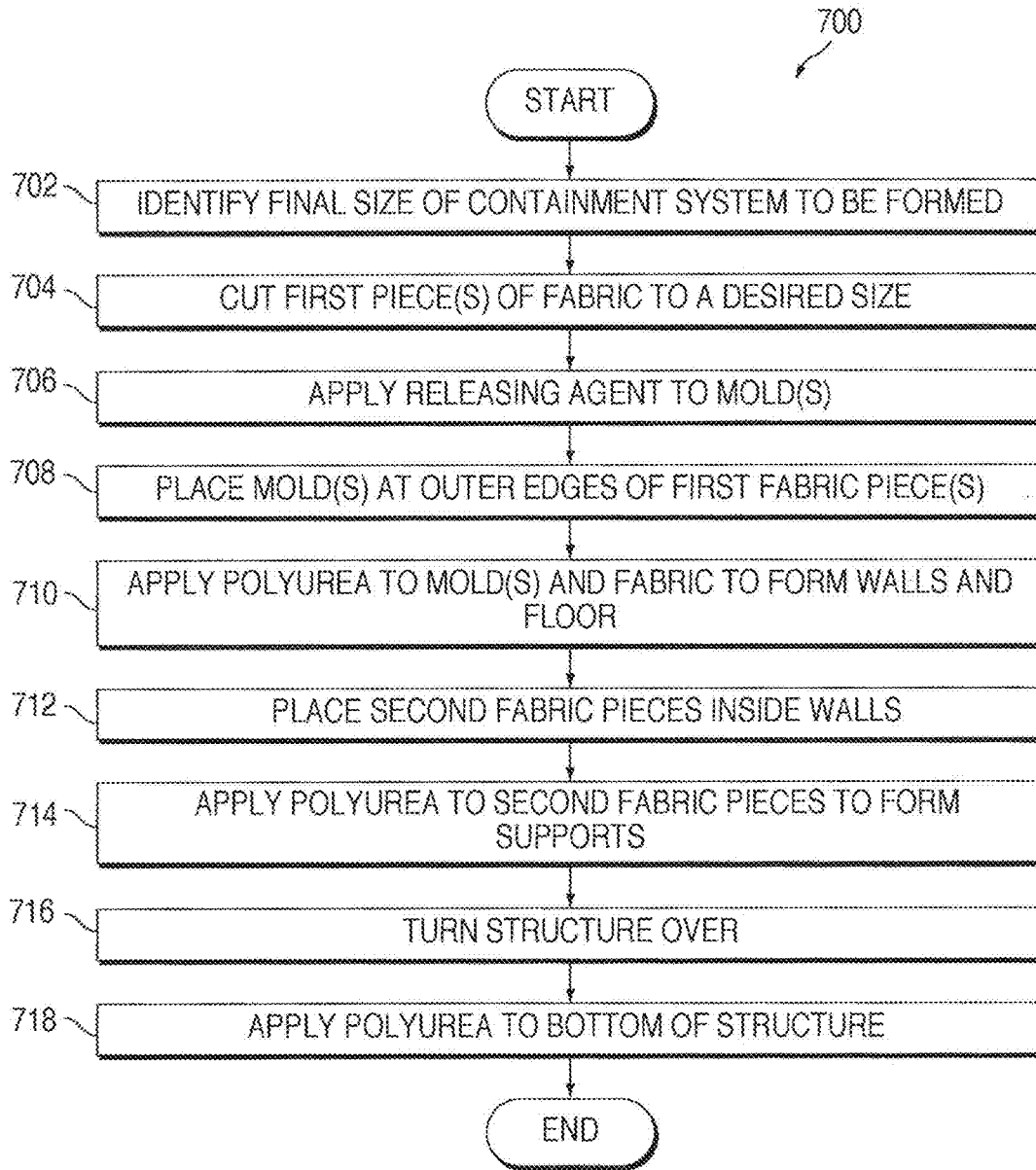

FIG. 7

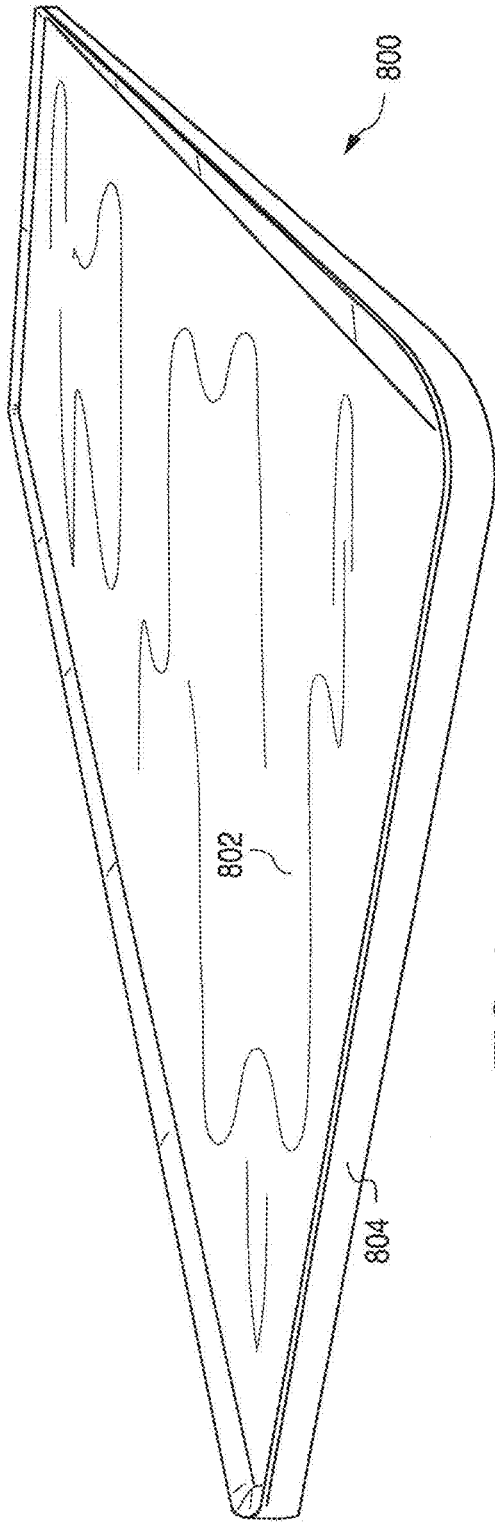

FIG. 8

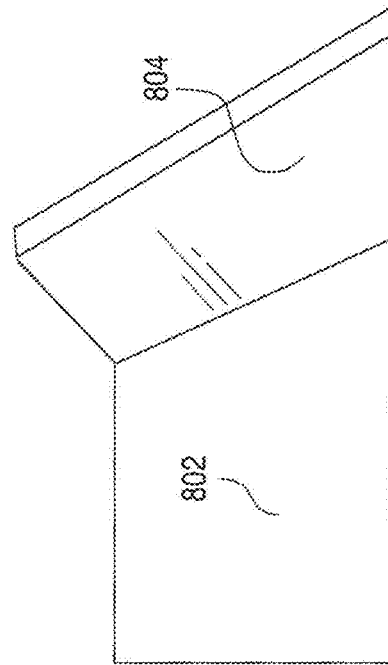

FIG. 9

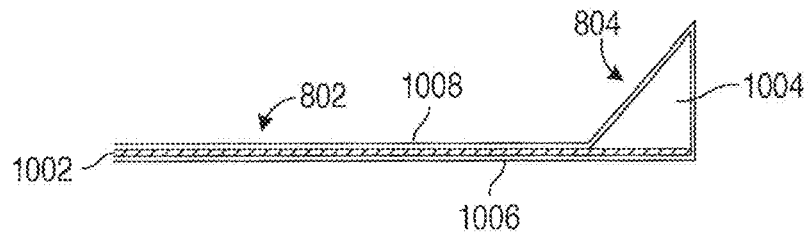

FIG. 10

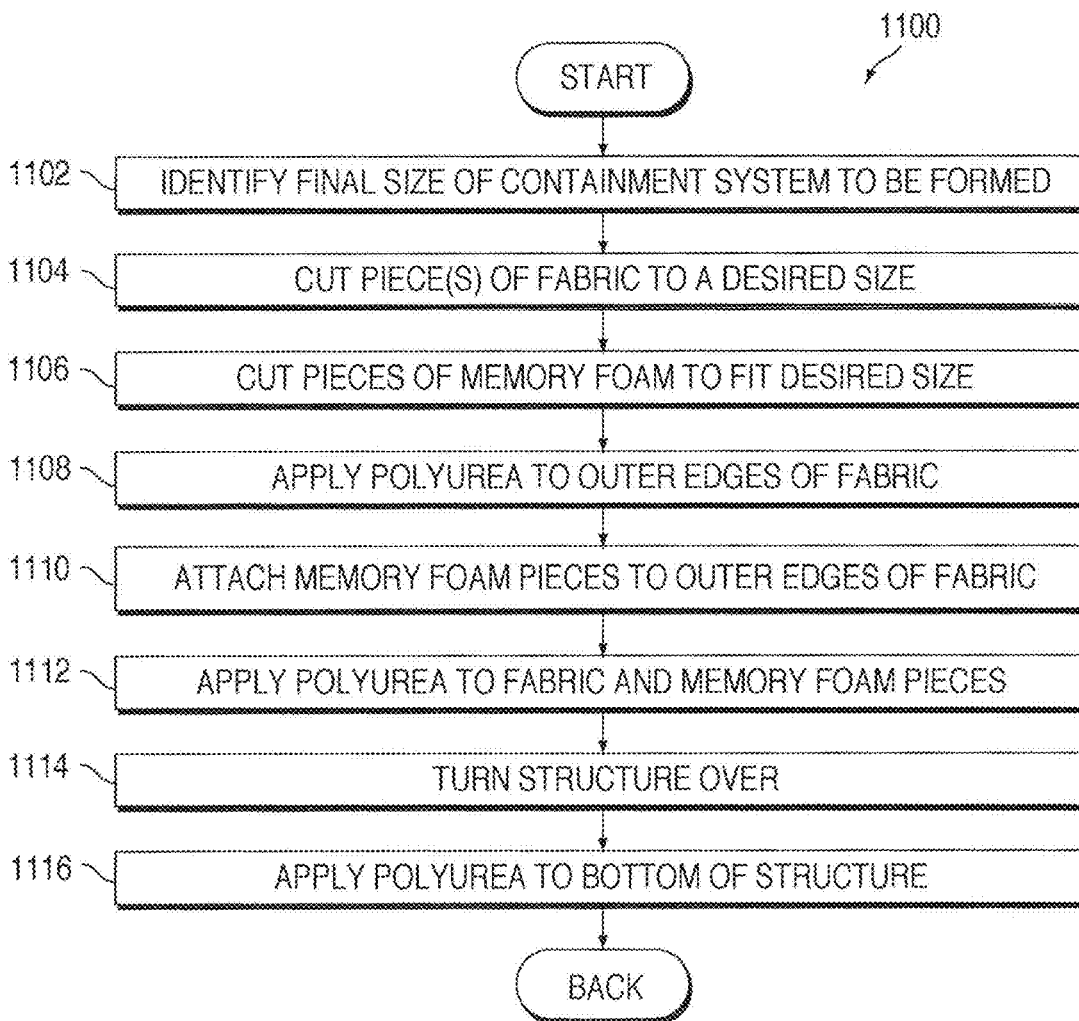

FIG. 11

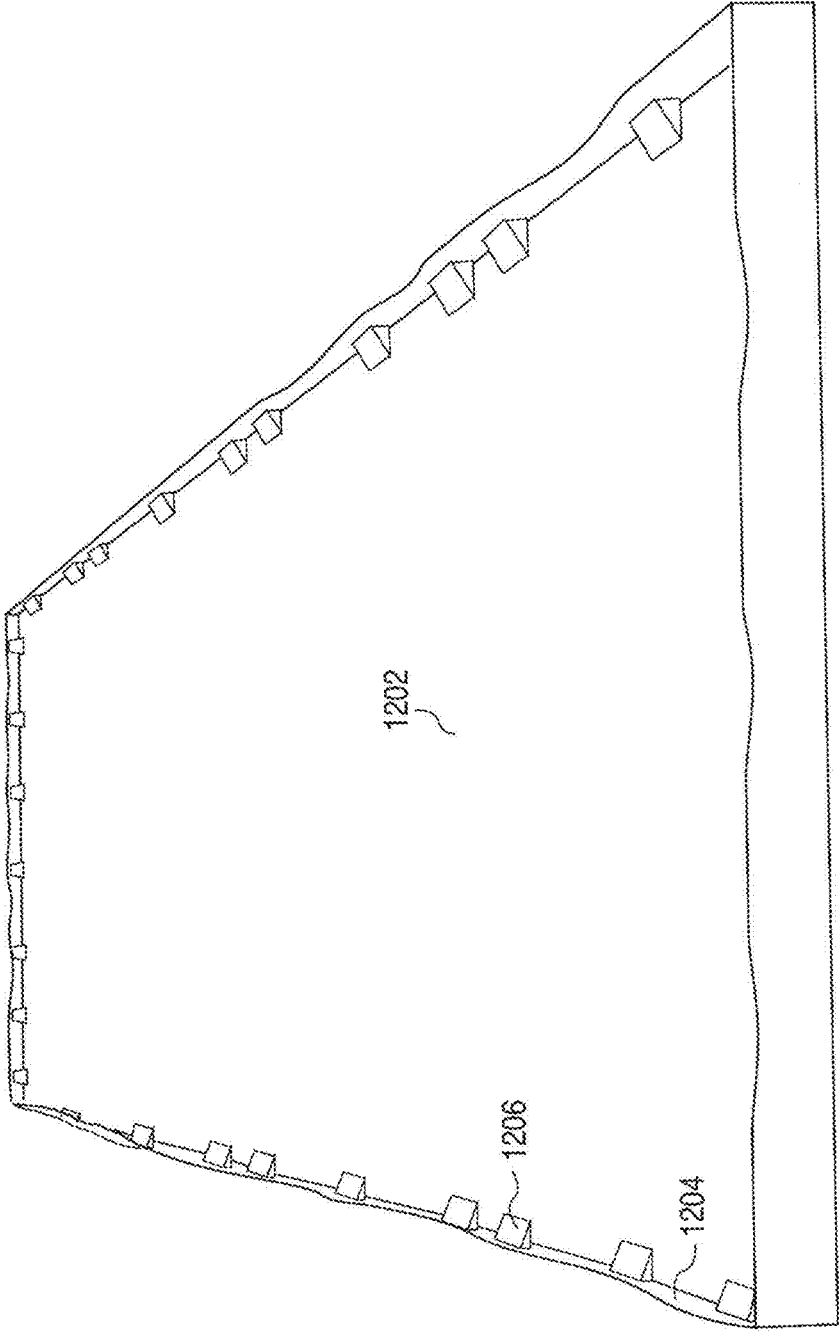

FIG. 12

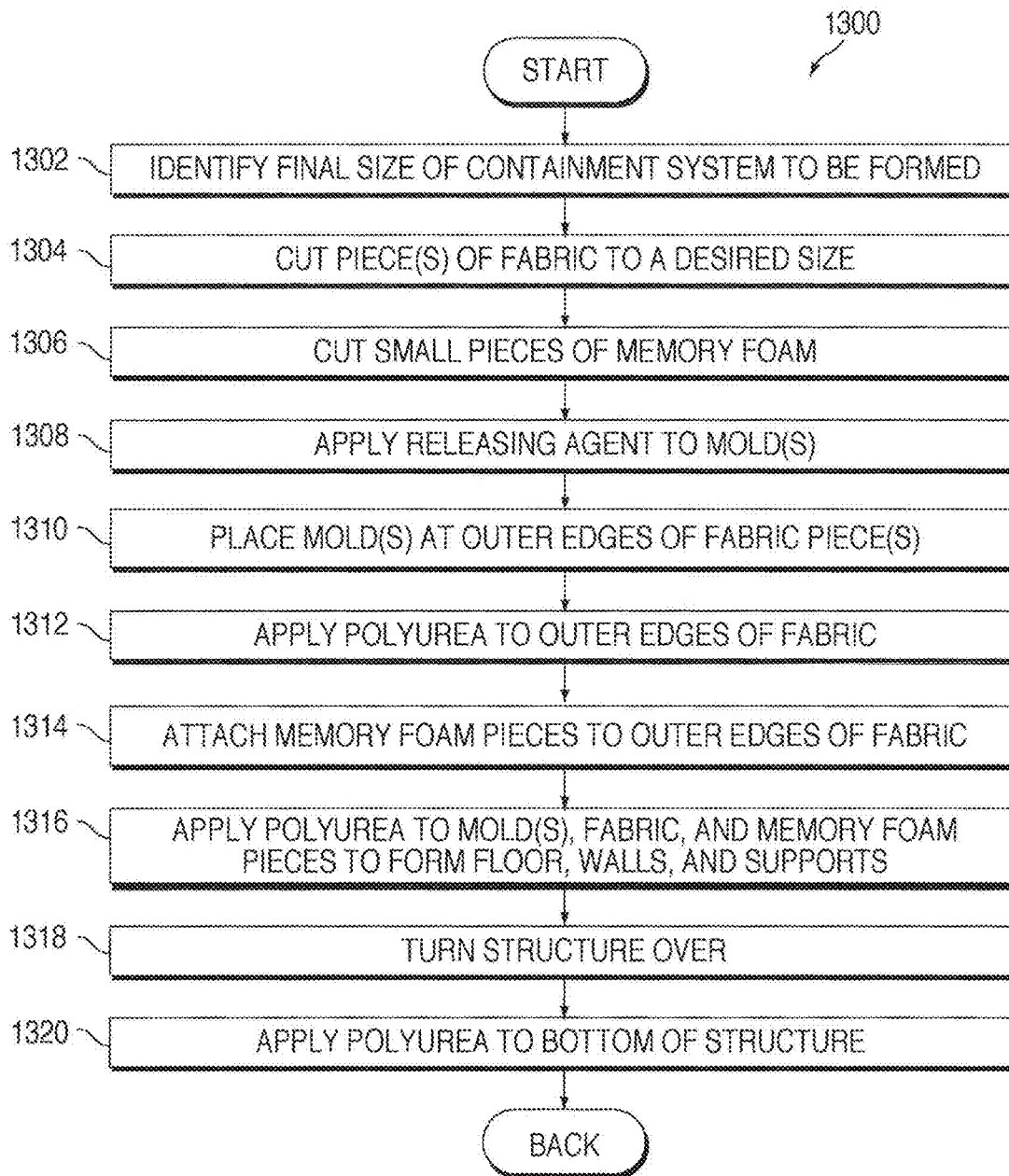

FIG. 13

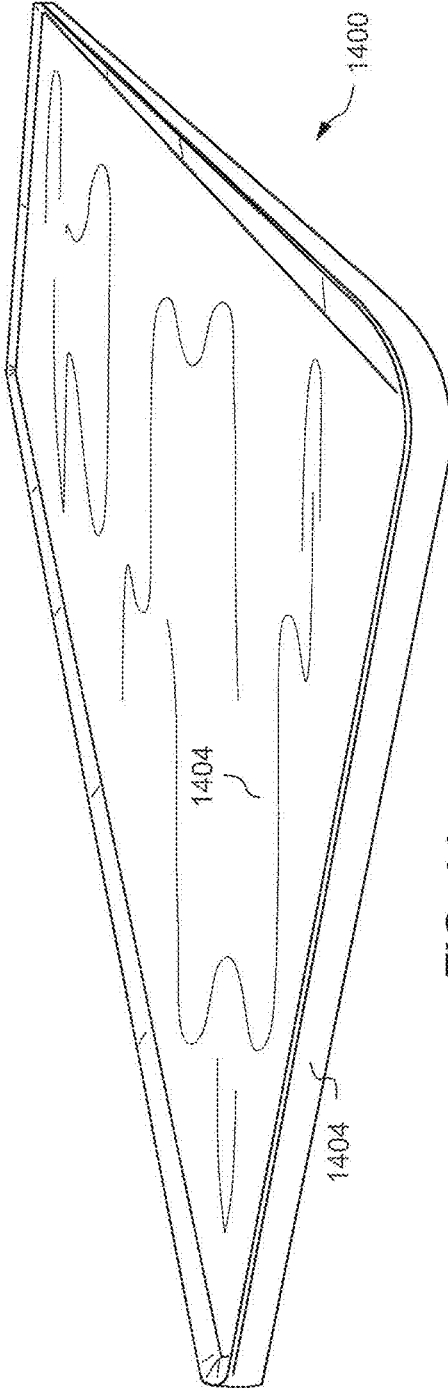

FIG. 14

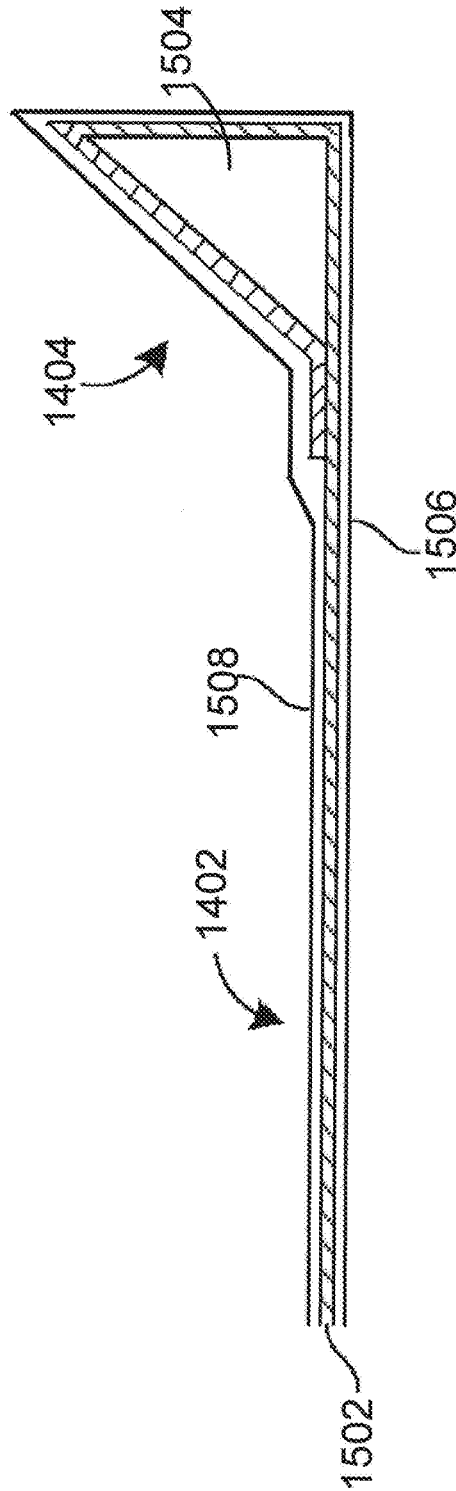

FIG. 15

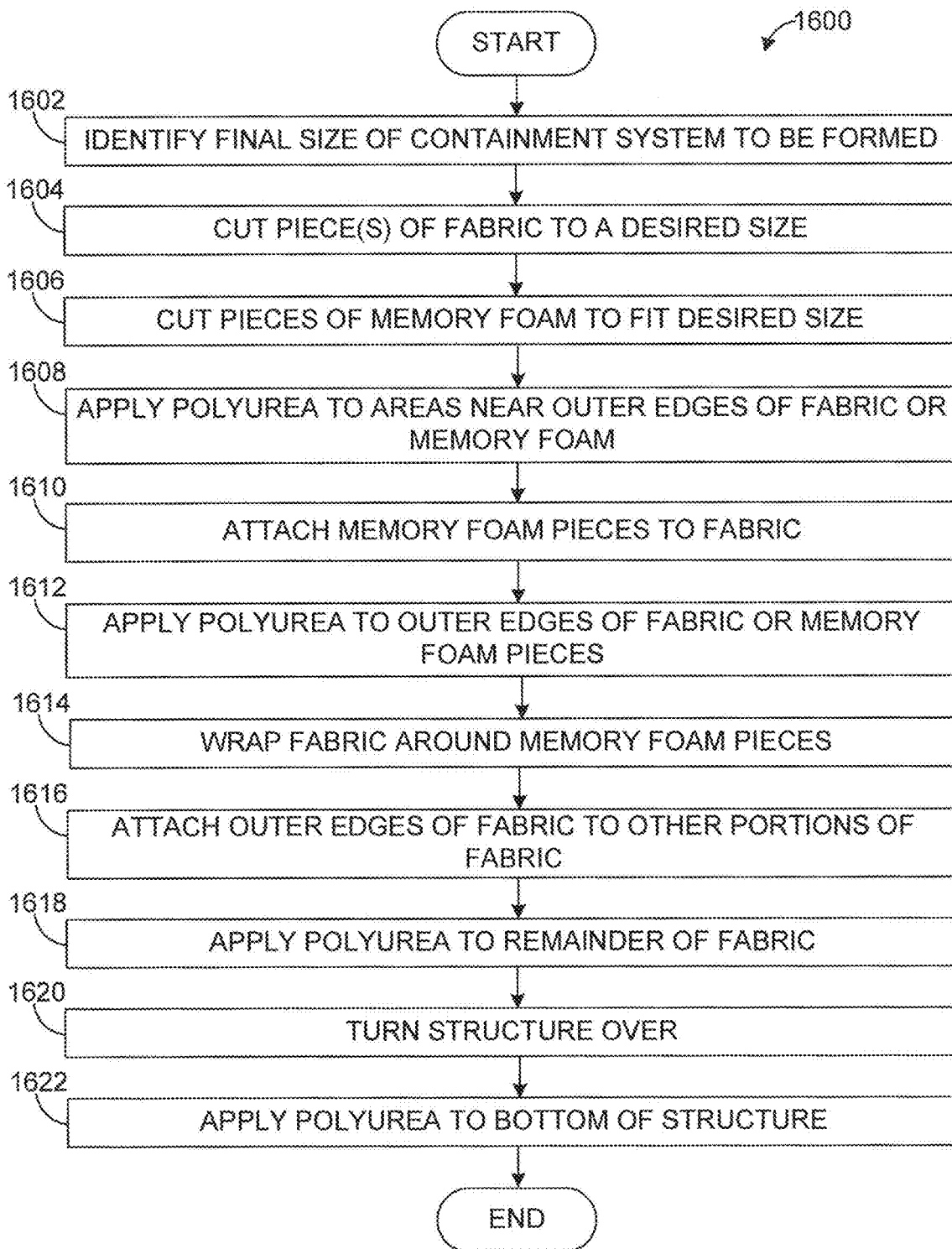

FIG. 16

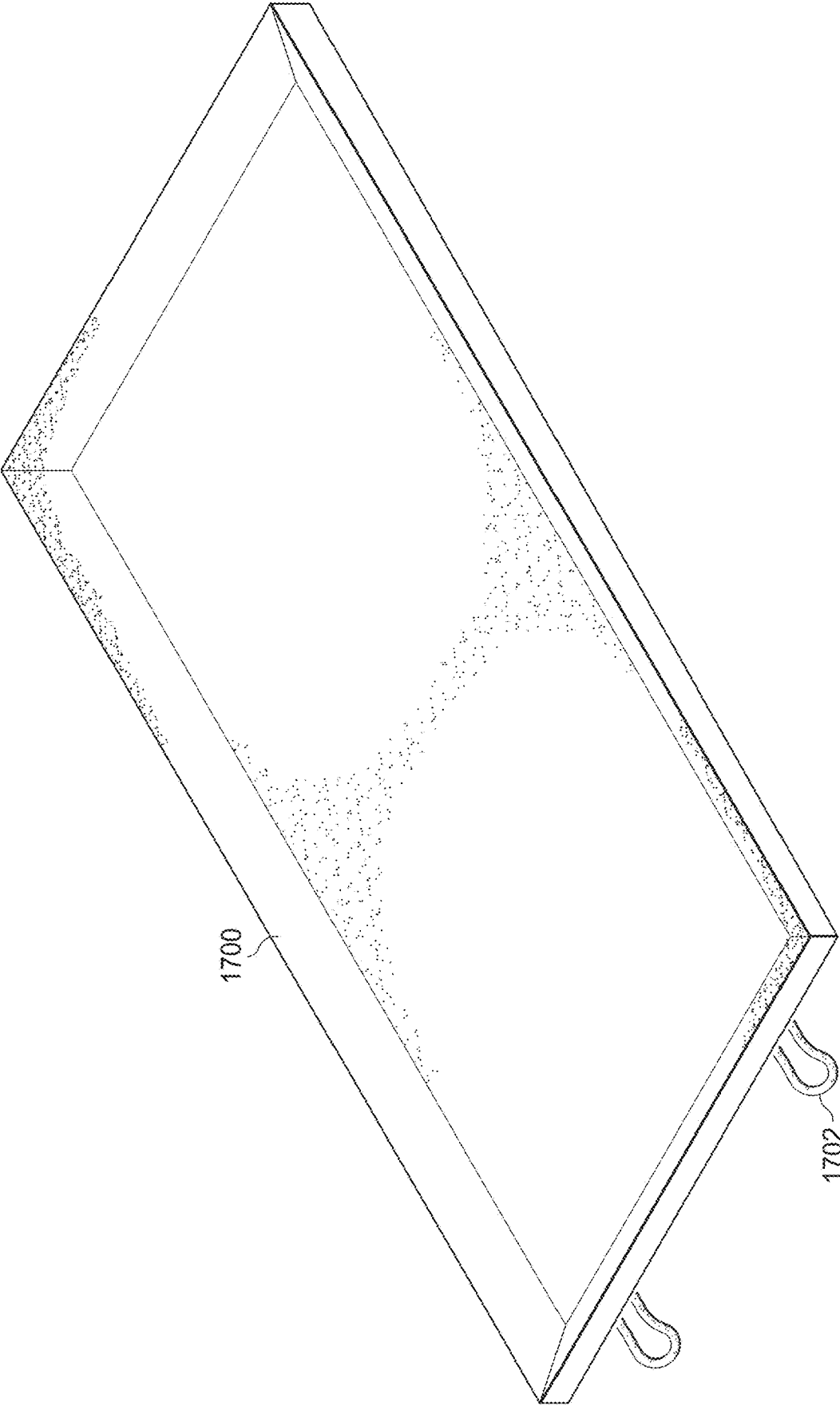

FIG. 17

PORTABLE CONTAINMENT SYSTEM FOR HAZARDOUS OR OTHER MATERIALS

CROSS-REFERENCE TO RELATED APPLICATIONS AND PRIORITY CLAIM

This application is a continuation of U.S. patent application Ser. No. 15/800,614 filed on Nov. 1, 2017 (now U.S. Pat. No. 10,131,494), which is a continuation of U.S. patent application Ser. No. 14/840,863 filed on Aug. 31, 2015 (now U.S. Pat. No. 9,828,173), which is a continuation of U.S. patent application Ser. No. 14/223,425 filed on Mar. 24, 2014 (now U.S. Pat. No. 9,126,745), which is a continuation-in-part of U.S. patent application Ser. No. 13/616,602 filed on Sep. 14, 2012 (now U.S. Pat. No. 8,998,013), which claims priority under 35 U.S.C. § 119(e) to U.S. Provisional Patent Application No. 61/535,760 filed on Sep. 16, 2011. All of these patent applications are hereby incorporated by reference.

TECHNICAL FIELD

This disclosure is generally directed to containment systems. More specifically, this disclosure is directed to a portable containment system for hazardous or other materials.

BACKGROUND

Often times, it is necessary or desirable to prevent material from being released or absorbed into the ground. For example, the release of hazardous or other materials into the ground could contaminate ground water or cause other problems. As a particular example, hazardous or other materials are often stored in tanks. Any spills or leaks of materials from the tanks could lead to contamination as well as civil or regulatory fines.

SUMMARY

This disclosure provides a portable containment system for hazardous or other materials.

In a first embodiment, an apparatus includes a containment structure having a floor and one or more free-standing flexible walls extending along an outer perimeter of the floor and surrounding a central portion of the floor. The floor includes one or more pieces of fabric, and each free-standing flexible wall includes one or more pieces of shape memory material and extending above the floor. The one or more pieces of shape memory material are attached to the one or more pieces of fabric via a liquid-impervious material applied to the one or more pieces of fabric along the outer perimeter of the floor. The liquid-impervious material is located on the one or more pieces of fabric and the one or more pieces of shape memory material such that the floor and the one or more free-standing flexible walls are liquid-impervious and define a space configured to retain liquid in the containment structure.

In a second embodiment, a method includes obtaining one or more pieces of shape memory material and arranging one or more pieces of fabric to form a floor of a containment structure. The method also includes applying a liquid-impervious material to the one or more pieces of fabric along an outer perimeter of the floor. The method further includes attaching the one or more pieces of shape memory material to the one or more pieces of fabric via the liquid-impervious material to form one or more free-standing flexible walls

extending along the outer perimeter of the floor, surrounding a central portion of the floor and extending above the floor. In addition, the method includes depositing the liquid-impervious material onto the one or more pieces of fabric and the one or more pieces of shape memory material such that the floor and the one or more free-standing flexible walls are liquid-impervious and define a space configured to retain liquid in the containment structure.

Other technical features may be readily apparent to one skilled in the art from the following figures, descriptions, and claims.

BRIEF DESCRIPTION OF THE DRAWINGS

For a more complete understanding of this disclosure, reference is now made to the following description, taken in conjunction with the accompanying drawings, in which:

FIGS. 1 through 6 illustrate a first example portable containment system in accordance with this disclosure;

FIG. 7 illustrates an example method for forming the portable containment system of FIGS. 1 through 6 according to this disclosure;

FIGS. 8 through 10 illustrate a second example portable containment system in accordance with this disclosure;

FIG. 11 illustrates an example method for forming the portable containment system of FIGS. 8 through 10 according to this disclosure;

FIG. 12 illustrates a third example portable containment system in accordance with this disclosure;

FIG. 13 illustrates an example method for forming the portable containment system of FIG. 12 according to this disclosure;

FIGS. 14 and 15 illustrate a fourth example portable containment system in accordance with this disclosure;

FIG. 16 illustrates an example method for forming the portable containment system of FIGS. 14 and 15 according to this disclosure; and

FIG. 17 illustrates example handles integrated into a portable containment system according to this disclosure.

DETAILED DESCRIPTION

FIGS. 1 through 17, discussed below, and the various embodiments used to describe the principles of the present invention in this patent document are by way of illustration only and should not be construed in any way to limit the scope of the invention. Those skilled in the art will understand that the principles of the invention may be implemented in any type of suitably arranged device or system.

FIGS. 1 through 6 illustrate a first example portable containment system 100 in accordance with this disclosure. FIG. 1 illustrates multiple instances of the portable containment system 100. The containment system 100 includes a bottom portion or floor 102 and free-standing walls 104. The containment system 100 operates to contain and hold material between the walls 104 and over the floor 102, thereby helping to prevent the material from being absorbed into the ground. In some embodiments, the containment system 100 is a seamless structure formed from polyurea and felt. However, the containment system 100 could be formed from any other suitable materials. Also, the containment system 100 can be used to hold and prevent release of any hazardous and nonhazardous material(s).

An example containment system 100 is shown in greater detail in FIGS. 2 through 6. For example, in FIGS. 2 and 3, the containment system 100 is shown with its floor 102 and free-standing walls 104. Multiple supports 202 attached to

3

the walls **104** and floor **102** help to support the walls **104** of the containment system **100**. For example, if liquid or other material leaks into the containment system **100**, the supports **202** can help retain the walls **104** in an upright position to hold the material within the containment system **100**. The supports **202** include any suitable structures for supporting the walls **104**, such as flexible supports.

One or more molds **204** are used to help form the containment system **100**. As described in more detail below, the molds **204** can be used to help form the walls **104** of the containment system **100**. Each mold **204** includes any suitable structure for helping to form at least part of the containment system **100**. For example, each mold **204** could represent an L-shaped wooden mold that is six inches tall and four inches wide. Other types of molds could also be used, such as carbon fiber molds. Moreover, molds having other sizes and shapes, such as rounded corners, could be used.

As shown in FIGS. **4** and **5**, once the containment system **100** is formed, the molds **204** can be removed, and material can be placed within the containment system **100**. In this case, water is being placed into the containment system **100** for testing purposes. The supports **202** help to keep the walls **104** upright as the containment system **100** is being filled with water.

The containment system **100** here is flexible and can be rolled or otherwise placed into a suitable form for transport. An example of this is shown in FIG. **6**, where the containment system **100** has been rolled for transport. Once at its intended destination, the containment system **100** can be placed on the ground and unrolled or otherwise placed into a suitable form for use, and equipment (such as one or more storage tanks) can be placed on the containment system **100**. When the equipment is being placed onto the containment system **100**, people or machinery can be used to drag or carry the equipment onto the containment system **100**. The walls **104** of the containment system **100** can flex or be pressed down during this time, and the walls **104** may return substantially to their pre-flexed shape (although some deformation of a wall **104** is permissible). This helps to facilitate easier placement of the equipment on the containment system **100**.

Note that the containment system **100** here does not require the use of metallic or other solid supports to hold the walls **104** of the containment system **100** upright. Among other things, this can enable simpler transport and use of the containment system **100**. For instance, the containment system **100** could be easily rolled into the form shown in FIG. **6** without requiring metallic or other solid supports to first be removed from the containment system **100**. Also, the containment system **100** could be easily unrolled into the form shown in FIG. **1** for use without requiring metallic or other solid supports to first be inserted into the containment system **100**.

Although FIGS. **1** through **6** illustrate a first example of a portable containment system **100**, various changes may be made to FIGS. **1** through **6**. For example, the containment system **100** could have any suitable size, shape, and dimensions. As particular examples, the containment system **100** could be of virtually any size as long as there is enough space to create walls for containing material meant to be contained. Also, the shape could be typically square or rectangular, although circular or other shapes could also be used. Further, the walls **104** could have any suitable height(s), such as six inches. Note that non-uniform heights are also possible. In addition, while the use of certain materials (such as polyurea and felt) is described here, any

4

other suitable materials can be used to form the containment system **100**. For instance, any suitable textiles or other fabrics could be used in the containment system **100** and covered with polyurea or other liquid-impervious material(s).

FIG. **7** illustrates an example method **700** for forming the portable containment system of FIGS. **1** through **6** according to this disclosure. As shown in FIG. **7**, a desired final size of the containment system is identified at step **702**. One or more first pieces of felt or other fabric are cut to a desired size at step **704**. Each first fabric piece could have any suitable size and shape, such as a rectangle four feet by twelve feet. One or multiple first pieces of fabric could be used here.

A releasing agent is applied to one or more molds at step **706**. The releasing agent could represent any suitable material(s) to help prevent bonding of the containment system **100** to the mold(s) **204**, such as a polyurea releasing agent. The molds are placed along outer edges of the first fabric piece(s) at step **708**. The molds define where the walls **104** are being formed and can be placed so that the walls **104** define a containment system **100** having the desired final shape. If the molds **204** are L-shaped, this step could include placing outer edges of the first fabric pieces on the bottom portions of the molds **204**.

Polyurea is applied to the mold(s) and fabric and cured to form the walls and floor of the containment system at step **710**. This could include, for example, spraying polyurea onto the molds **204** and first fabric pieces and allowing the polyurea to cure. Any suitable amount of polyurea can be applied to the walls **104** and floor **102** of the containment system **100**.

To form supports for the walls, second felt or other fabric pieces are placed inside the walls of the containment system at step **712**. This could include, for example, cutting pieces of fabric and placing the fabric pieces spaced apart along the inner walls **104** of the containment structure. In particular embodiments, the second fabric pieces can be about two inches by eight inches, and the second fabric pieces can be placed about 3.5 feet apart. Note that any other suitable uniform or non-uniform sizes and spacings can be used. Polyurea is applied to the second fabric pieces to form the supports at step **714**.

The containment structure is turned over at step **716**, and polyurea is applied to the bottom of the structure at step **718**. The polyurea used here could represent a light application of polyurea meant to protect the underside of the structure. Once completed, the containment system can be used in any suitable manner.

Although FIG. **7** illustrates one example of a method **700** for forming the portable containment system **100** of FIGS. **1** through **6**, various changes may be made to FIG. **7**. For example, while shown as a series of steps, various steps in FIG. **7** could overlap, occur in parallel, or occur in a different order. Also, while the use of certain materials (such as polyurea and felt) is described here, any other suitable materials can be used to form the containment system. In addition, note that spraying represents one way of depositing a liquid-impervious material onto a structure and that other deposition techniques could be used.

FIGS. **8** through **10** illustrate a second example portable containment system **800** in accordance with this disclosure. FIG. **8** illustrates multiple instances of the portable containment system **800**. The containment system **800** includes a bottom portion or floor **802** and free-standing walls **804**. The containment system **800** operates to contain and hold material between the walls **804** and over the floor **802**, thereby

5

helping to prevent the material from being absorbed into the ground. In some embodiments, the containment system **800** is a seamless structure formed from polyurea, felt, and memory foam. However, the containment system **800** could be formed from any other suitable materials. Also, the containment system **800** can be used to hold and prevent release of any hazardous and nonhazardous material(s).

A portion of the containment system **800** is shown in greater detail in FIG. **9** and in cross-section in FIG. **10**. In FIG. **9**, the containment system **800** is shown with its floor **802** and a free-standing wall **804**. The wall **804** here is generally triangular in shape, although the wall **804** could have any other desired shape(s). If liquid or other material leaks into the containment system **800**, the walls **804** remain in an upright position to hold the material within the containment system **800**. The walls **804** can be formed using memory foam material or other type of shape memory material(s), which allows the walls **804** to be deformed during use.

As shown in FIG. **10**, the wall **804** of the containment system **800** could be formed using felt **1002** and memory foam material **1004**. The felt **1002** and memory foam material **1004** can be covered by layers **1006-1008** of polyurea to create a liquid-impervious structure. Once again, note that the memory foam material **1004** could have any other desired shape, and any other material(s) could be used in place of the felt **1002**.

The containment system **800** here is flexible and can be rolled or otherwise placed into a suitable form for transport (similar to that shown in FIG. **6**). Once at its intended destination, the containment system **800** can be placed on the ground and unrolled or otherwise placed into a suitable form for use, and equipment (such as one or more storage tanks) can be placed on the containment system **800**. When the equipment is being placed onto the containment system **800**, people or machinery can be used to drag or carry the equipment onto the containment system **800**. The walls **804** of the containment system **800** can be depressed, and the walls **804** may return substantially to their pre-depressed shape (although some deformation of a wall **804** is permissible). This helps to facilitate easier placement of the equipment on the containment system **800**.

Note that the containment system **800** here does not require the use of metallic or other solid supports to hold the walls **804** of the containment system **800** upright. Among other things, this can enable simpler transport and use of the containment system **800**. For instance, the containment system **800** could be easily rolled into a form similar to that shown in FIG. **6** without requiring metallic or other solid supports to first be removed from the containment system **800**. Also, the containment system **800** could be easily unrolled into the form shown in FIG. **8** for use without requiring metallic or other solid supports to first be inserted into the containment system **800**.

Although FIGS. **8** through **10** illustrate a second example of a portable containment system **800**, various changes may be made to FIGS. **8** through **10**. For example, the containment system **800** could have any suitable size, shape, and dimensions. As particular examples, the containment system **800** could be of virtually any size as long as there is enough space to create walls for containing material meant to be contained. Also, the shape could be typically square or rectangular, although circular or other shapes could also be used. Further, the walls **804** could have any suitable height(s), and non-uniform heights are also possible. In addition, while the use of certain materials (such as polyurea, felt, and memory foam) is described here, any other

6

suitable materials can be used to form the containment system **800**. For instance, any suitable textiles or other fabrics could be used in the containment system **800** and covered with polyurea or other liquid-impervious material(s). Moreover, any suitable shape-memory material(s) could be used in the walls **804** of the containment system **800**.

FIG. **11** illustrates an example method **1100** for forming the portable containment system of FIGS. **8** through **10** according to this disclosure. As shown in FIG. **11**, a desired final size of the containment system is identified at step **1102**. One or more pieces of felt or other fabric are cut to a desired size at step **1104**. Each fabric piece could have any suitable size and shape, such as a rectangle four feet by twelve feet. One or multiple pieces of fabric could be used here.

One or more pieces of memory foam are cut to fit the desired size at step **1106**. The memory foam could be cut so that one or more pieces fit along the outer edges of the fabric piece(s). The memory foam pieces define where the walls **804** are being formed.

Polyurea is applied to the outer edges of the fabric at step **1108**, and the memory foam pieces are attached to the outer edges of the fabric at step **1110**. The memory foam pieces are therefore attached to the outer edges of the fabric when the polyurea cures.

Polyurea is applied onto the fabric and memory foam pieces at step **1112**. The containment structure is turned over at step **1114**, and polyurea is applied to the bottom of the structure at step **1116**. Any suitable amount of polyurea can be applied to the walls **804** and floor **802** of the containment system **800**. Once completed, the containment system can be used in any suitable manner.

Although FIG. **11** illustrates one example of a method **1100** for forming the portable containment system of FIGS. **8** through **10**, various changes may be made to FIG. **11**. For example, while shown as a series of steps, various steps in FIG. **11** could overlap, occur in parallel, or occur in a different order. Also, while the use of certain materials (such as polyurea, felt, and memory foam) is described here, any other suitable materials can be used to form the containment system. In addition, note that spraying represents one way of depositing a liquid-impervious material onto a structure and that other deposition techniques could be used.

FIG. **12** illustrates a third example portable containment system **1200** in accordance with this disclosure. As shown in FIG. **12**, the containment system **1200** includes a floor **1202** and walls **1204**. The floor **1202** can be formed using felt or other fabric(s), and the floor **1202** and the walls **1204** can be formed using polyurea or other liquid-impervious material(s). These structures could be formed in the same or similar manner as in the containment system **100** described above.

The containment system **1200** also includes multiple supports **1206** attached to the walls **1204** and floor **1202**. The supports **1206** can be formed using memory foam material or other type of shape memory material(s). These structures could be formed in the same or similar manner as in the containment system **800** described above, except the shape memory material in the supports **1206** is not continuous around the entire containment system **1200**. The walls **1204** and supports **1206** here can be deformed during use and may return substantially to their pre-flexed shape (although some deformation of a wall **1204** or support **1206** is permissible).

Although FIG. **12** illustrates a third example of a portable containment system **1200**, various changes may be made to FIG. **12**. For example, the containment system **1200** could have any suitable size, shape, and dimensions. As particular examples, the containment system **1200** could be of virtually

any size as long as there is enough space to create walls for containing material meant to be contained. Also, the shape could be typically square or rectangular, although circular or other shapes could also be used. Further, the walls **1204** could have any suitable height(s), and non-uniform heights are also possible. Moreover, the supports **1206** could have any suitable size and shape, and any number of supports **1206** could be used. In addition, while the use of certain materials (such as polyurea, felt, and memory foam) is described here, any other suitable materials can be used to form the containment system **1200**. For instance, any suitable textiles or other fabrics could be used in the containment system **1200** and covered with polyurea or other liquid-impervious material(s). Beyond that, any suitable shape-memory material(s) could be used in the supports **1206** of the containment system **1200**.

FIG. **13** illustrates an example method **1300** for forming the portable containment system of FIG. **12** according to this disclosure. As shown in FIG. **13**, a desired final size of the containment system is identified at step **1302**. One or more pieces of felt or other fabric are cut to a desired size at step **1304**. Each fabric piece could have any suitable size and shape, such as a rectangle four feet by twelve feet. One or multiple pieces of fabric could be used here. Multiple pieces of memory foam are cut at step **1306**. The memory foam could be cut so that the supports **1206** have any suitable size and shape, such as triangular wedges.

A releasing agent is applied to one or more molds at step **1308**. The releasing agent could represent any suitable material(s) to help prevent bonding of the containment system **1200** to the mold(s), such as a polyurea releasing agent. The molds are placed along outer edges of the fabric piece(s) at step **1310**. If the molds are L-shaped, this step could include placing outer edges of the fabric pieces on the bottom portions of the molds.

Polyurea is applied to the outer edges of the fabric at step **1312**, and the memory foam pieces are attached to the outer edges of the fabric at step **1314**. The memory foam pieces are therefore attached to the outer edges of the fabric when the polyurea cures.

Polyurea is applied to the mold(s), fabric, and memory foam pieces and cured to form the floor, walls, and supports of the containment system at step **1316**. This could include, for example, spraying polyurea onto the molds, fabric pieces, and memory foam pieces and allowing the polyurea to cure. Any suitable amount of polyurea can be applied to the floor **1202**, walls **1204**, and supports **1206** of the containment system **1200**.

The containment structure is turned over at step **1318**, and polyurea is applied to the bottom of the structure at step **1320**. The polyurea used here could represent a light application of polyurea meant to protect the underside of the structure. Once completed, the containment system can be used in any suitable manner.

Although FIG. **13** illustrates one example of a method **1300** for forming the portable containment system **1200** of FIG. **12**, various changes may be made to FIG. **13**. For example, while shown as a series of steps, various steps in FIG. **13** could overlap, occur in parallel, or occur in a different order. Also, while the use of certain materials (such as polyurea, felt, and memory foam) is described here, any other suitable materials can be used to form the containment system. In addition, note that spraying represents one way of depositing a liquid-impervious material onto a structure and that other deposition techniques could be used.

FIGS. **14** and **15** illustrate a fourth example portable containment system **1400** in accordance with this disclosure.

In FIG. **14**, the portable containment system **1400** has the same general structure as the portable containment system **800** shown in FIG. **8**. The portable containment system **1400** includes a bottom portion or floor **1402** and free-standing walls **1404**. The containment system **1400** operates to contain and hold material between the walls **1404** and over the floor **1402**, thereby helping to prevent the material from being absorbed into the ground. In some embodiments, the containment system **1400** is a seamless structure formed from polyurea, felt, and memory foam. However, the containment system **1400** could be formed from any other suitable materials. Also, the containment system **1400** can be used to hold and prevent release of any hazardous and nonhazardous material(s). In addition, the walls **1404** could have any suitable cross-sectional shape.

As shown in FIG. **15**, the wall **1404** of the containment system **1400** could be formed using felt **1502** and memory foam material **1504** (or other shape memory material). The felt **1502** and memory foam material **1504** can be covered by layers **1506-1508** of polyurea to create a liquid-impervious structure. Once again, note that the memory foam material **1504** could have any other desired shape, and any other material(s) could be used in place of the felt **1502**.

Unlike the approach shown in FIG. **10**, the felt **1502** here wraps around the memory foam material **1504**. The bottom of the memory foam material **1504** can be attached to the felt **1502**, such as by using polyurea, at a location that is spaced some distance from the edge of the felt **1502**. The felt **1502** could then be wrapped up and over the memory foam material **1504**, possibly while being attached to the sides of the memory foam material **1504** (such as with polyurea). Finally, the outer edge of the felt **1502** can be secured to another portion of the felt **1502**, such as by using polyurea, before the top surface of the structure is covered in the layer **1508** of polyurea. Effectively, the memory foam material **1504** is wrapped in and possibly attached to the felt **1502**.

The containment system **1400** here is flexible and can be rolled or otherwise placed into a suitable form for transport (similar to that shown above). Once at its intended destination, the containment system **1400** can be placed on the ground and unrolled or otherwise placed into a suitable form for use, and equipment (such as one or more storage tanks) can be placed on the containment system **1400**. When the equipment is being placed onto the containment system **1400**, people or machinery can be used to drag or carry the equipment onto the containment system **1400**. The walls **1404** of the containment system **1400** can be depressed, and the walls **1404** may return substantially to their pre-depressed shape (although some deformation of a wall **1404** is permissible). This helps to facilitate easier placement of the equipment on the containment system **1400**.

Note that the containment system **1400** again does not require the use of metallic or other solid supports to hold the walls **1404** of the containment system **1400** upright. This can provide various advantages, such as those discussed above.

Although FIGS. **14** and **15** illustrate a fourth example of a portable containment system **1400**, various changes may be made to FIGS. **14** and **15**. For example, the containment system **1400** could have any suitable size, shape, and dimensions. As particular examples, the containment system **1400** could be of virtually any size as long as there is enough space to create walls for containing material meant to be contained. Also, the shape could be typically square or rectangular, although circular or other shapes could also be used. Further, the walls **1404** could have any suitable height(s), and non-uniform heights are also possible. In addition, while the use of certain materials (such as polyu-

rea, felt, and memory foam) is described here, any other suitable materials can be used to form the containment system **1400**. For instance, any suitable textiles or other fabrics could be used in the containment system **1400** and covered with polyurea or other liquid-impervious material(s). Moreover, any suitable shape-memory material(s) could be used in the walls **1404** of the containment system **1400**.

FIG. **16** illustrates an example method **1600** for forming the portable containment system of FIGS. **14** and **15** according to this disclosure. As shown in FIG. **16**, a desired final size of the containment system is identified at step **1602**. One or more pieces of felt or other fabric are cut to a desired size at step **1604**. Each fabric piece could have any suitable size and shape, such as a rectangle four feet by twelve feet. One or multiple pieces of fabric could be used here. One or more pieces of memory foam are cut to fit the desired size at step **1606**. The memory foam could be cut so that one or more pieces fit close to (but are spaced some distance apart from) the outer edges of the fabric piece(s). The memory foam pieces define where the walls **1404** are being formed.

Polyurea is applied near the outer edges of the fabric and/or the memory foam pieces at step **1608**, and the memory foam pieces are attached to the fabric at step **1610**. The memory foam pieces are therefore attached close to (but spaced apart from) the outer edges of the fabric when the polyurea cures. Polyurea is applied onto the outer edges of the fabric or the memory foam pieces at step **1612**, and the fabric is wrapped around the memory foam pieces at step **1614**. This wraps the fabric around the memory foam pieces. Note, however, that a side of the memory foam piece(s) could also be secured to the fabric along the outer edge, and the memory foam piece(s) could then be rolled to wrap the memory foam piece(s) in fabric. As a result, any suitable technique for wrapping a memory foam piece in fabric could be used here.

The outer edges of the fabric are attached to other portions of the fabric at step **1616**. This could include, for example, using the polyurea along the outer edges of the fabric to attach the outer edges of the fabric to other areas of the fabric. Polyurea is applied onto the remainder of the fabric at step **1618**. The containment structure is turned over at step **1620**, and polyurea is applied to the bottom of the structure at step **1622**. Any suitable amount of polyurea can be applied to the walls **1404** and floor **1402** of the containment system **1400**. Once completed, the containment system **1400** can be used in any suitable manner.

Although FIG. **16** illustrates one example of a method **1600** for forming the portable containment system of FIGS. **14** and **15**, various changes may be made to FIG. **16**. For example, while shown as a series of steps, various steps in FIG. **16** could overlap, occur in parallel, or occur in a different order. Also, while the use of certain materials (such as polyurea, felt, and memory foam) is described here, any other suitable materials can be used to form the containment system. In addition, note that spraying represents one way of depositing a liquid-impervious material onto a structure and that other deposition techniques could be used.

FIG. **17** illustrates example handles integrated into a portable containment system **1700** according to this disclosure. In this example, two handles **1702** are integrated into the portable containment system **1700**. The handles **1702** can be used to maneuver the portable containment system **1700**.

In some embodiments, the handles **1702** could be formed by cutting relief slits in the flooring of the portable containment system **1700** and bringing the handles **1702** to the perimeter of the portable containment system **1700**. At that

point, the handles **1702** are allowed to hang free from the portable containment system **1700**. The structure is then sprayed with polyurea to attach the handles to the floor of the portable containment system **1700**.

In other embodiments, the handles **1702** can be formed along the walls or floor of the containment system **1700** using a “cut and weave” design to attach the handles to the felt pieces. The structure is then sprayed with polyurea to seal the handles **1702** to the structure.

Although FIG. **17** illustrates one example of handles **1702** integrated into a portable containment system **1700**, various changes may be made to FIG. **17**. For example, while the portable containment system **1700** appears to have continuous walls formed using memory foam material, any of the portable containment systems described above could include handles **1702** formed in the same or similar manner. Also, while the portable containment system **1700** is shown as having two handles along a shorter edge of the containment system, a portable containment system could include any number of handles in any suitable arrangement.

Note that the containment systems **100**, **800**, **1200**, **1400**, **1700** could include any other suitable features as desired depending on the implementation. For example, at one end of the containment system **100**, **800**, **1200**, **1400**, **1700**, multiple tabs can be formed with holes or openings. As a particular example, multiple tabs formed by felt covered in polyurea can be placed at one end of the containment system **100**, **800**, **1200**, **1400**, **1700**, such as tabs formed using one foot by two foot pieces of felt. The tabs could include oblong openings, such as openings of around one inch by five inches in size. A forklift operator can place the forklift’s fingers into the openings of the tabs, allowing the forklift operator to raise and lower the containment system **100**, **800**, **1200**, **1400**, **1700** without requiring the forklift to physically touch the floor and walls of the containment system **100**, **800**, **1200**, **1400**, **1700**. As another example, serial number tags, company logos, or other components can be attached to a containment system **100**, **800**, **1200**, **1400**, **1700** before, during, or after fabrication of the containment system **100**, **800**, **1200**, **1400**, **1700**. Any other or additional features could be used in the containment system **100**, **800**, **1200**, **1400**, **1700**.

It may be advantageous to set forth definitions of certain words and phrases that have been used within this patent document. The terms “include” and “comprise,” as well as derivatives thereof, mean inclusion without limitation. The term “or” is inclusive, meaning and/or. The phrase “associated with” and derivatives thereof may mean to include, be included within, interconnect with, contain, be contained within, connect to or with, couple to or with, be communicable with, cooperate with, interleave, juxtapose, be proximate to, be bound to or with, have, have a property of, have a relationship to or with, or the like.

While this disclosure has described certain embodiments and generally associated methods, alterations and permutations of these embodiments and methods will be apparent to those skilled in the art. Accordingly, the above description of example embodiments does not define or constrain this invention. Other changes, substitutions, and alterations are also possible without departing from the spirit and scope of this invention as defined by the following claims.

What is claimed is:

1. An apparatus comprising:

a containment structure comprising a floor and one or more free-standing flexible walls extending along an outer perimeter of the floor and surrounding a central portion of the floor, the floor comprising one or more

11

pieces of fabric, each free-standing flexible wall comprising one or more pieces of shape memory material and extending above the floor;

wherein the one or more pieces of shape memory material are attached to the one or more pieces of fabric via a liquid-impervious material applied to the one or more pieces of fabric along the outer perimeter of the floor; wherein the liquid-impervious material is located on the one or more pieces of fabric and the one or more pieces of shape memory material such that the floor and the one or more free-standing flexible walls are liquid-impervious and define a space configured to retain liquid in the containment structure; and wherein the floor does not extend beyond the one or more free-standing flexible walls.

2. The apparatus of claim 1, wherein at least one of the one or more pieces of fabric is at least partially wrapped around the one or more pieces of shape memory material.

3. The apparatus of claim 2, wherein the at least one of the one or more pieces of fabric wrapped at least partially around the one or more pieces of shape memory material is attached via liquid-impervious material.

4. The apparatus of claim 1, wherein the liquid-impervious material is located on a bottom side of the one or more pieces of fabric to protect an underside of the containment structure.

5. The apparatus of claim 1, wherein:

the one or more pieces of fabric comprise one or more pieces of felt;

the one or more pieces of shape memory material comprise one or more pieces of memory foam; and

the liquid-impervious material comprises polyurea.

6. The apparatus of claim 1, wherein the one or more free-standing flexible walls comprise multiple pieces of shape memory material attached to one another via liquid-impervious material.

7. The apparatus of claim 1, wherein the one or more free-standing flexible walls comprise a single piece of shape memory material.

8. An apparatus comprising:

a containment structure comprising a floor and one or more free-standing flexible walls extending along an outer perimeter of the floor and surrounding a central portion of the floor, the floor comprising one or more pieces of fabric, each free-standing flexible wall comprising one or more pieces of shape memory material and extending above the floor;

wherein the one or more pieces of shape memory material are attached to the one or more pieces of fabric via a liquid-impervious material applied to the one or more pieces of fabric along the outer perimeter of the floor; and

wherein the liquid-impervious material is located on the one or more pieces of fabric and the one or more pieces of shape memory material such that the floor and the one or more free-standing flexible walls are liquid-impervious and define a space configured to retain liquid in the containment structure; and

multiple tabs located at one end of the containment structure, each tab comprising liquid-impervious material on one or more additional pieces of fabric, the tabs defining openings configured to receive fingers of a forklift.

9. An apparatus comprising:

a containment structure comprising a floor and one or more free-standing flexible walls extending along an outer perimeter of the floor and surrounding a central

12

portion of the floor, the floor comprising one or more pieces of fabric, each free-standing flexible wall comprising one or more pieces of shape memory material and extending above the floor;

wherein the one or more pieces of shape memory material are attached to the one or more pieces of fabric via a liquid-impervious material applied to the one or more pieces of fabric along the outer perimeter of the floor; and

wherein the liquid-impervious material is located on the one or more pieces of fabric and the one or more pieces of shape memory material such that the floor and the one or more free-standing flexible walls are liquid-impervious and define a space configured to retain liquid in the containment structure; and

one or more handles, each handle connected to the containment structure and sealed to the containment structure using liquid-impervious material.

10. The apparatus of claim 9, wherein the floor does not extend beyond the one or more free-standing flexible walls.

11. A method comprising:

obtaining one or more pieces of shape memory material; arranging one or more pieces of fabric to form a floor of a containment structure;

applying a liquid-impervious material to the one or more pieces of fabric along an outer perimeter of the floor; attaching the one or more pieces of shape memory material to the one or more pieces of fabric via the liquid-impervious material to form one or more free-standing flexible walls extending along the outer perimeter of the floor, surrounding a central portion of the floor and extending above the floor; and

depositing the liquid-impervious material onto the one or more pieces of fabric and the one or more pieces of shape memory material such that the floor and the one or more free-standing flexible walls are liquid-impervious and define a space configured to retain liquid in the containment structure;

wherein the floor does not extend beyond the one or more free-standing flexible walls.

12. The method of claim 11, further comprising: wrapping at least one of the one or more pieces of fabric at least partially around the one or more pieces of shape memory material.

13. The method of claim 12, further comprising: attaching the at least one of the one or more pieces of fabric wrapped at least partially around the one or more pieces of shape memory material via liquid-impervious material.

14. The method of claim 11, further comprising: depositing the liquid-impervious material onto a bottom side of the one or more pieces of fabric to protect an underside of the containment structure.

15. The method of claim 11, wherein the free-standing flexible walls are configured to be repeatedly depressed and to return substantially to their pre-depressed shape.

16. The method of claim 11, further comprising: rolling up the containment structure without removing any portion of the free-standing flexible walls.

17. The method of claim 11, further comprising: attaching multiple pieces of shape memory material to one another via liquid-impervious material to form the one or more free-standing flexible walls.

18. A method comprising:

obtaining one or more pieces of shape memory material; arranging one or more pieces of fabric to form a floor of a containment structure;

13

applying a liquid-impervious material to the one or more pieces of fabric along an outer perimeter of the floor; attaching the one or more pieces of shape memory material to the one or more pieces of fabric via the liquid-impervious material to form one or more free-standing flexible walls extending along the outer perimeter of the floor, surrounding a central portion of the floor and extending above the floor;

depositing the liquid-impervious material onto the one or more pieces of fabric and the one or more pieces of shape memory material such that the floor and the one or more free-standing flexible walls are liquid-impervious and define a space configured to retain liquid in the containment structure; and

forming multiple tabs located at one end of the containment structure, each tab comprising liquid-impervious material on one or more additional pieces of fabric, the tabs defining openings configured to receive fingers of a forklift.

19. The method of claim 18, wherein the floor does not extend beyond the one or more free-standing flexible walls.

14

20. A method comprising:

obtaining one or more pieces of shape memory material; arranging one or more pieces of fabric to form a floor of a containment structure;

applying a liquid-impervious material to the one or more pieces of fabric along an outer perimeter of the floor; attaching the one or more pieces of shape memory material to the one or more pieces of fabric via the liquid-impervious material to form one or more free-standing flexible walls extending along the outer perimeter of the floor, surrounding a central portion of the floor and extending above the floor;

depositing the liquid-impervious material onto the one or more pieces of fabric and the one or more pieces of shape memory material such that the floor and the one or more free-standing flexible walls are liquid-impervious and define a space configured to retain liquid in the containment structure; and

forming one or more handles, each handle connected to the containment structure and sealed to the containment structure using liquid-impervious material.

* * * * *