

(19) **United States**

(12) **Patent Application Publication**  
**Baik et al.**

(10) **Pub. No.: US 2015/0204590 A1**  
(43) **Pub. Date: Jul. 23, 2015**

(54) **VARIABLE VOLUME RECEIVER FOR REFRIGERATING CYCLE, REFRIGERATING CYCLE COMPRISING THE VARIABLE RECEIVER, AND METHOD FOR CONTROLLING THE REFRIGERATING CYCLE**

(30) **Foreign Application Priority Data**

Aug. 30, 2012 (KR) ..... 10-2012-0095486

**Publication Classification**

(71) Applicant: **KOREA INSTITUTE OF ENERGY RESEARCH**, Daejeon (KR)

(51) **Int. Cl.**  
*F25B 49/02* (2006.01)  
*F25B 43/00* (2006.01)

(72) Inventors: **Young Jin Baik**, Daejeon (KR);  
**Minsung Kim**, Daejeon (KR);  
**Ki-Chang Chang**, Daejeon (KR);  
**Young-Soo Lee**, Seoul (KR); **Ho-Sang Ra**, Daejeon (KR)

(52) **U.S. Cl.**  
CPC ..... *F25B 49/02* (2013.01); *F25B 43/00* (2013.01)

(73) Assignee: **KOREA INSTITUTE OF ENERGY RESEARCH**, Daejeon (KR)

(57) **ABSTRACT**

(21) Appl. No.: **14/419,947**  
(22) PCT Filed: **Aug. 28, 2013**  
(86) PCT No.: **PCT/KR2013/007716**  
§ 371 (c)(1),  
(2) Date: **Feb. 6, 2015**

A variable volume receiver for a refrigerating cycle, according to the present invention, can adjust the capacity of storing a refrigerant according to changes in driving conditions, such as outside air temperature or a load-side temperature, and can secure a proper degree of sub-cooling even when the driving conditions change, thereby providing the advantage of enabling optimum driving regardless of changes in the outside air temperature or the load-side temperature.

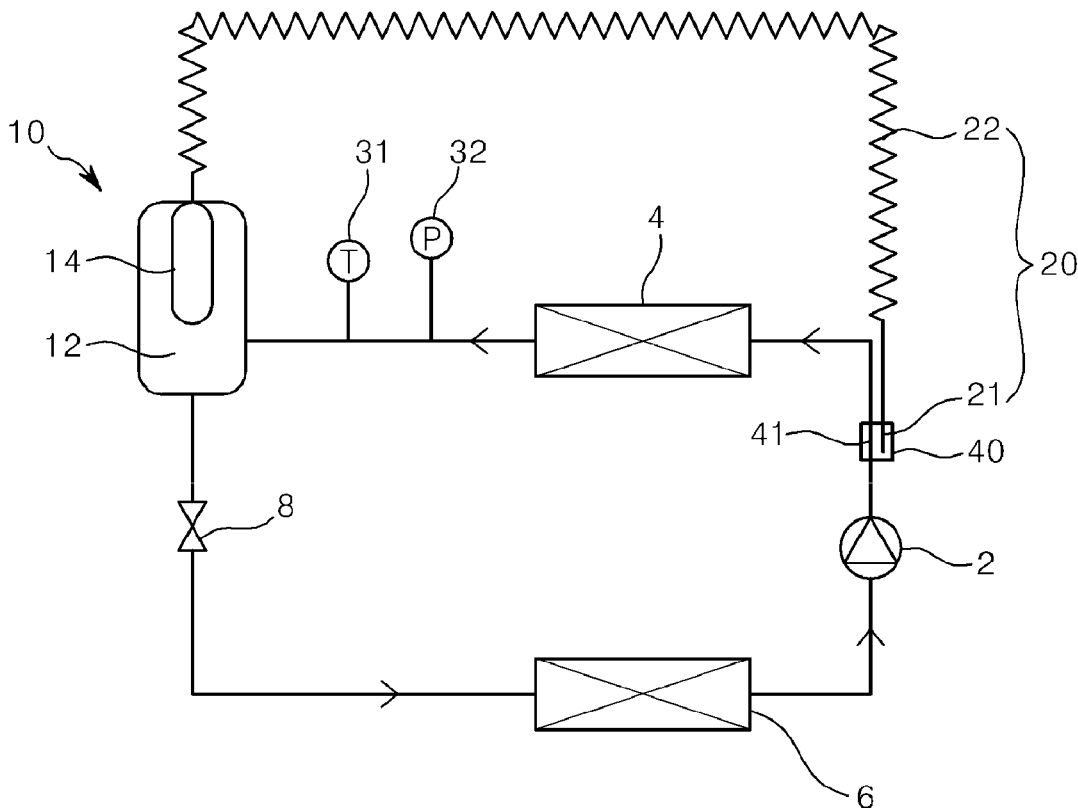

FIG. 1

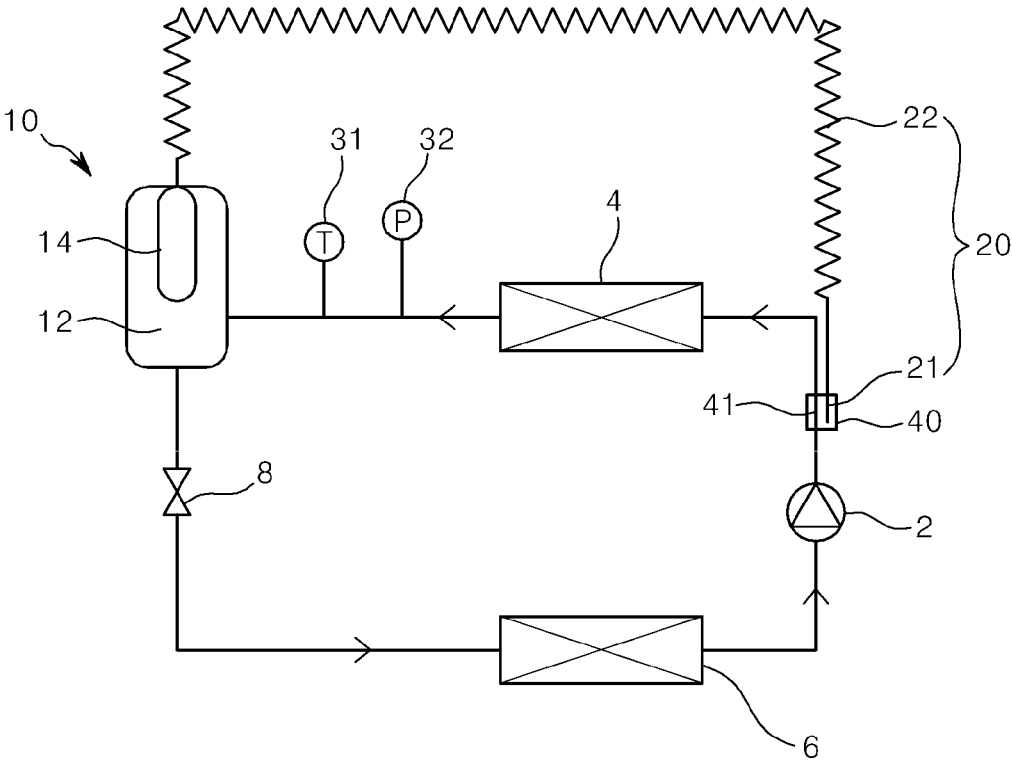

FIG. 2

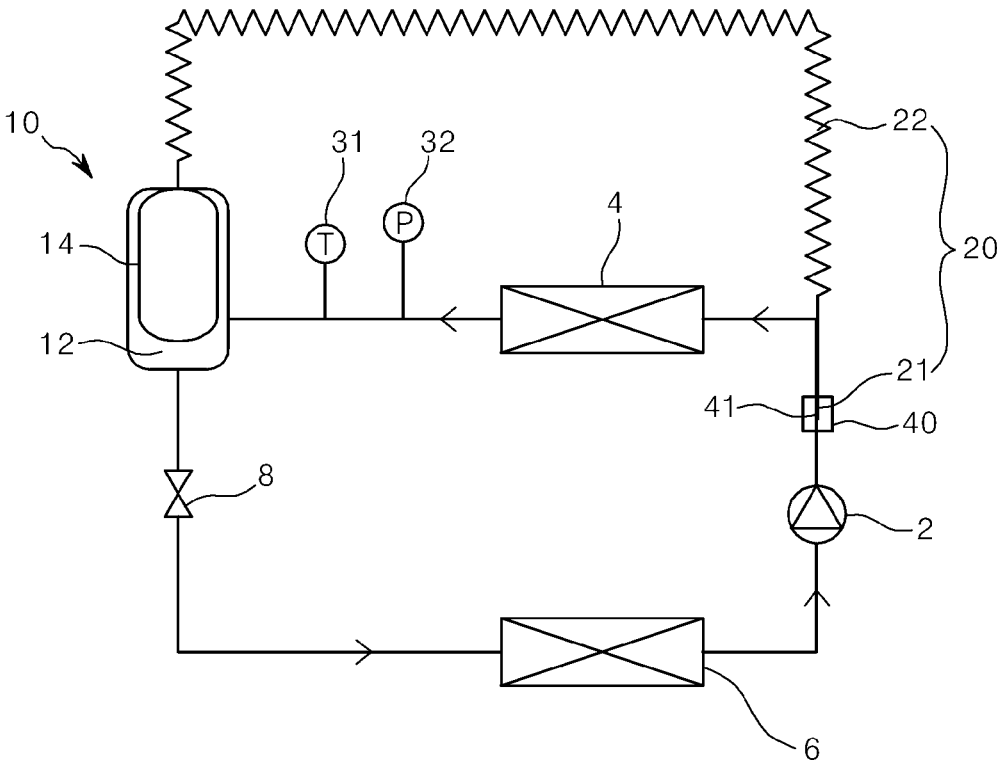

FIG. 3

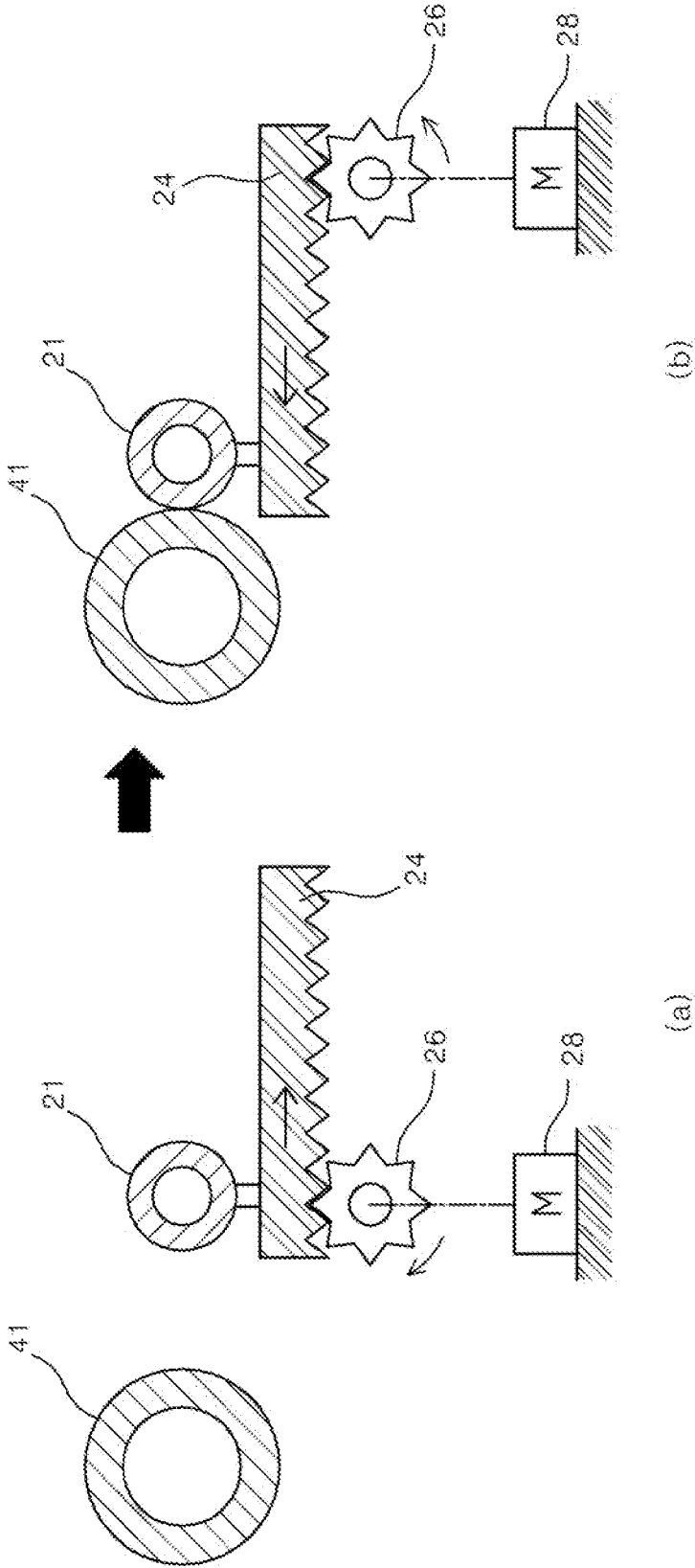

FIG. 4

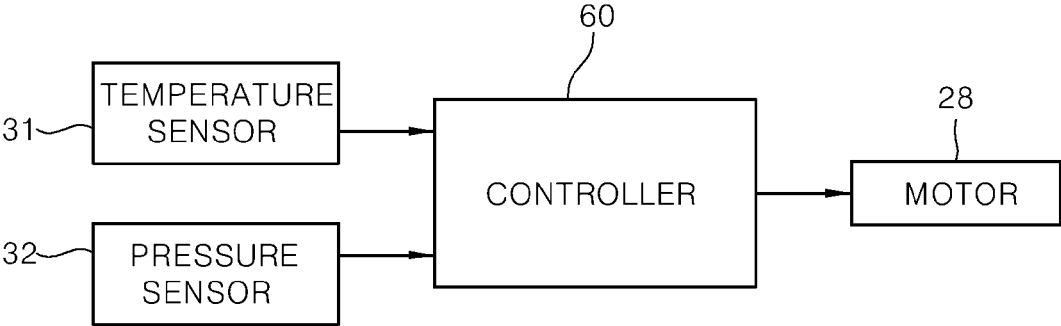

FIG. 5

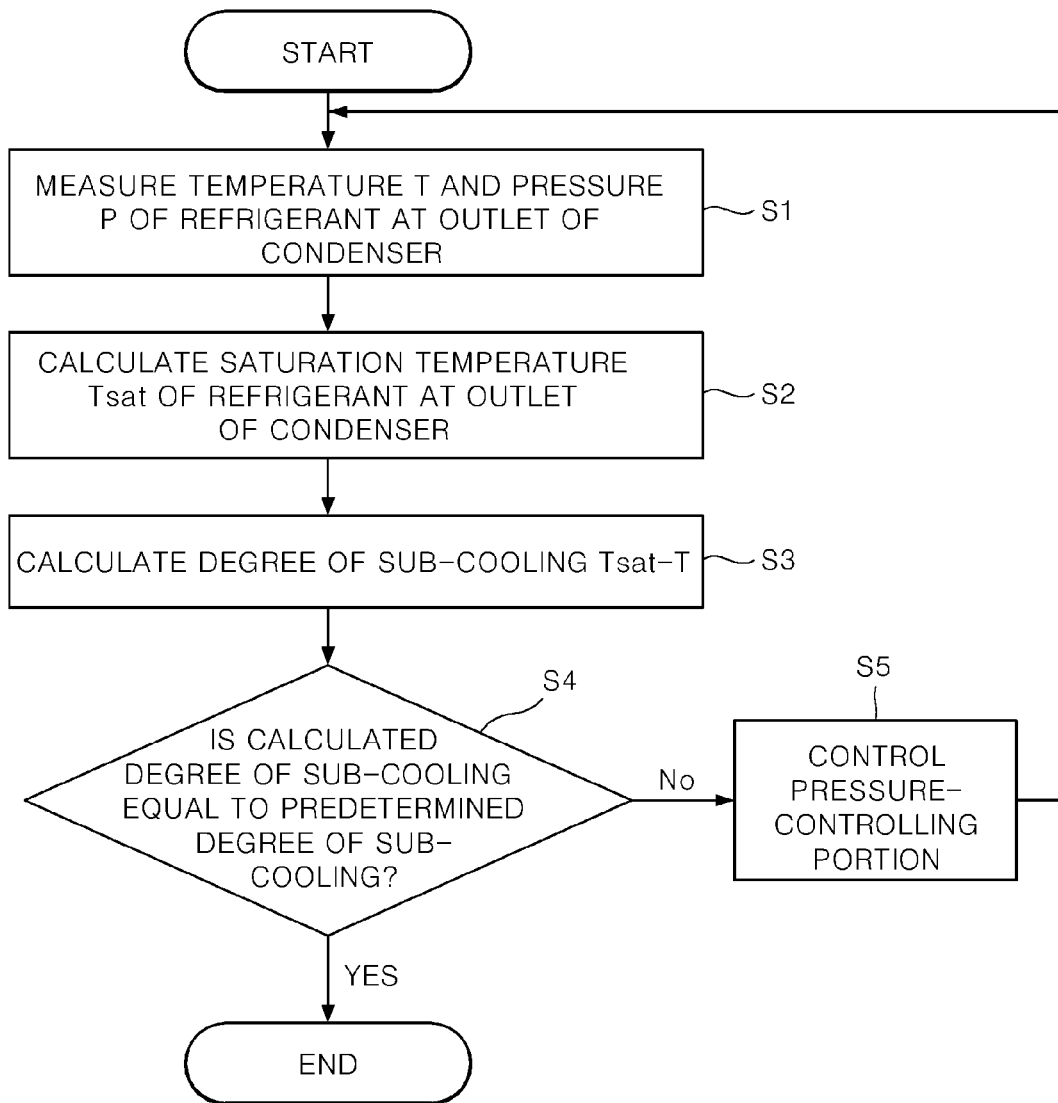

FIG. 6

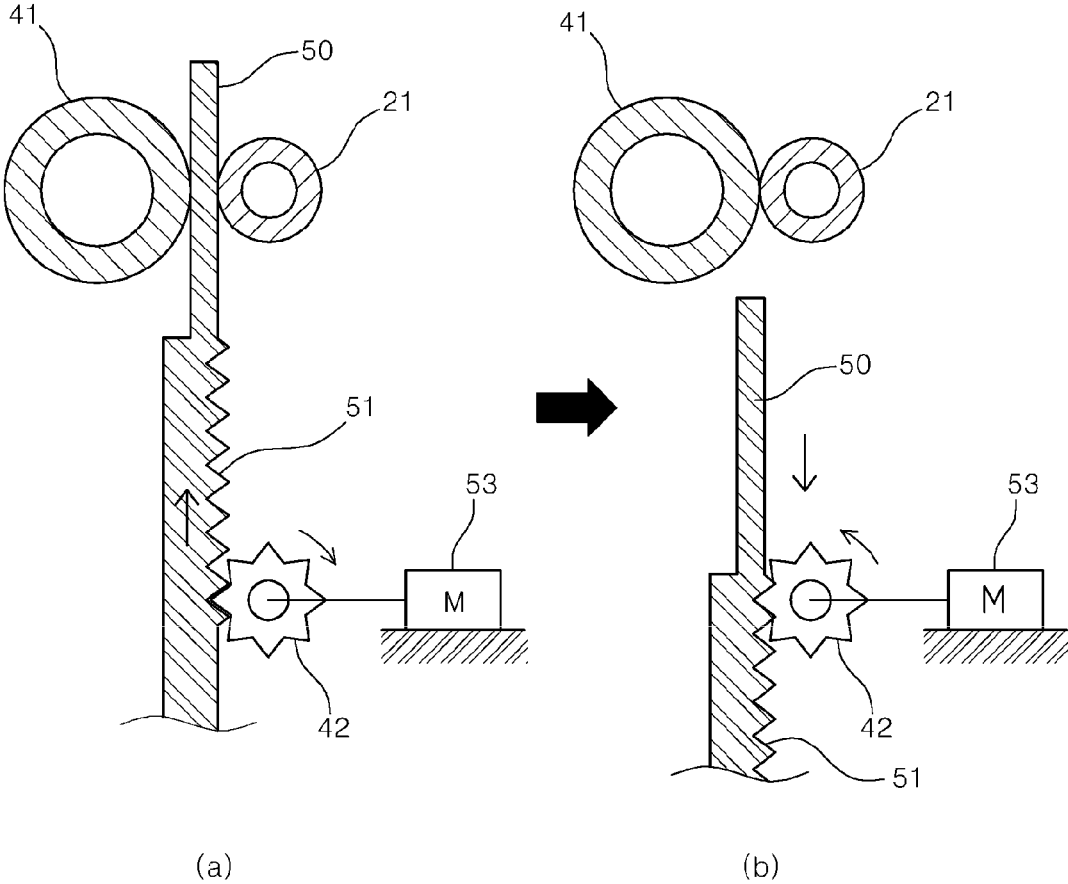

FIG. 7

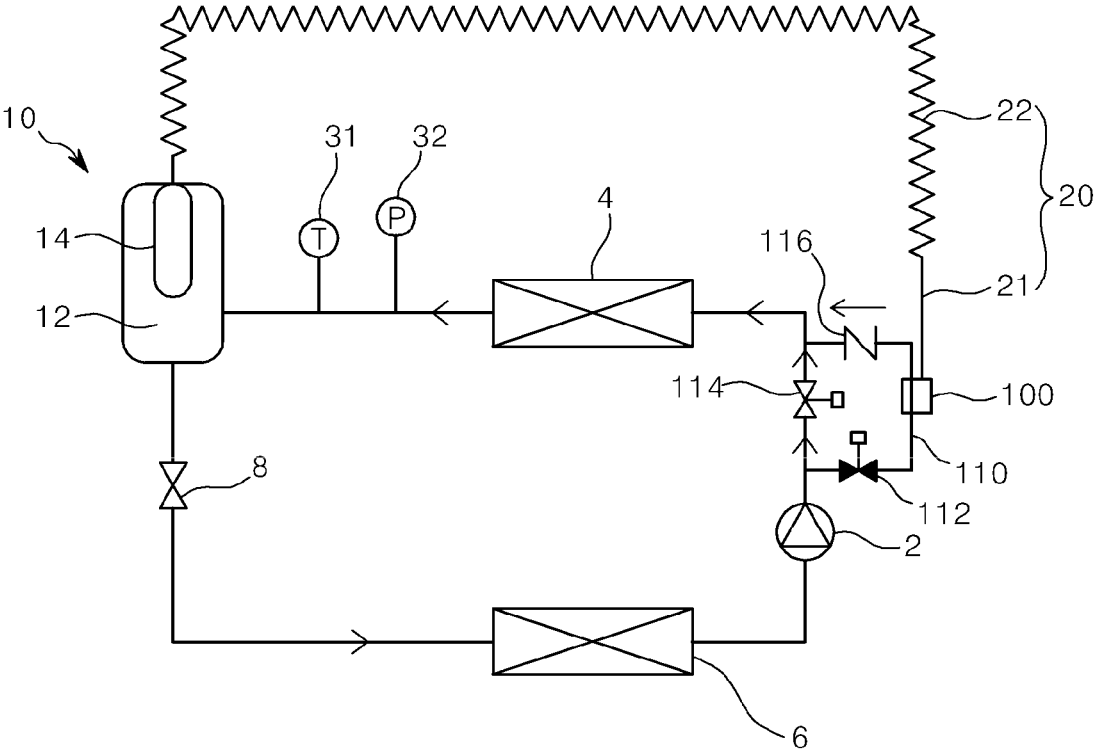



FIG. 8

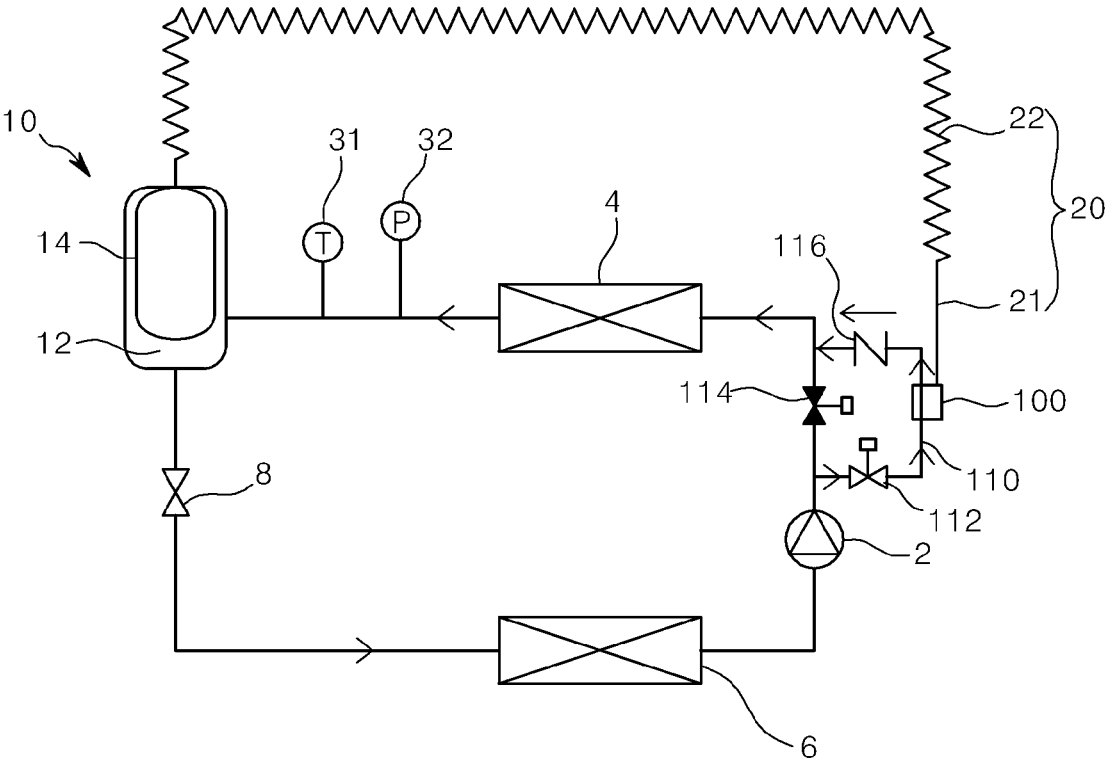

FIG. 9

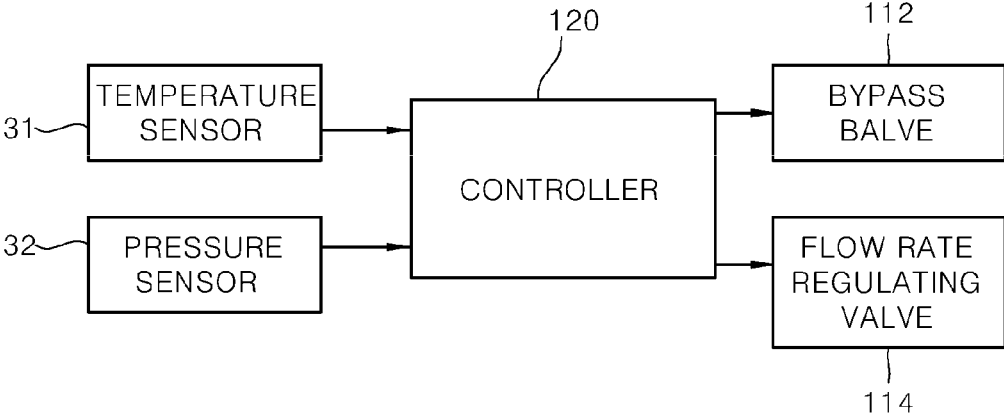

FIG. 10

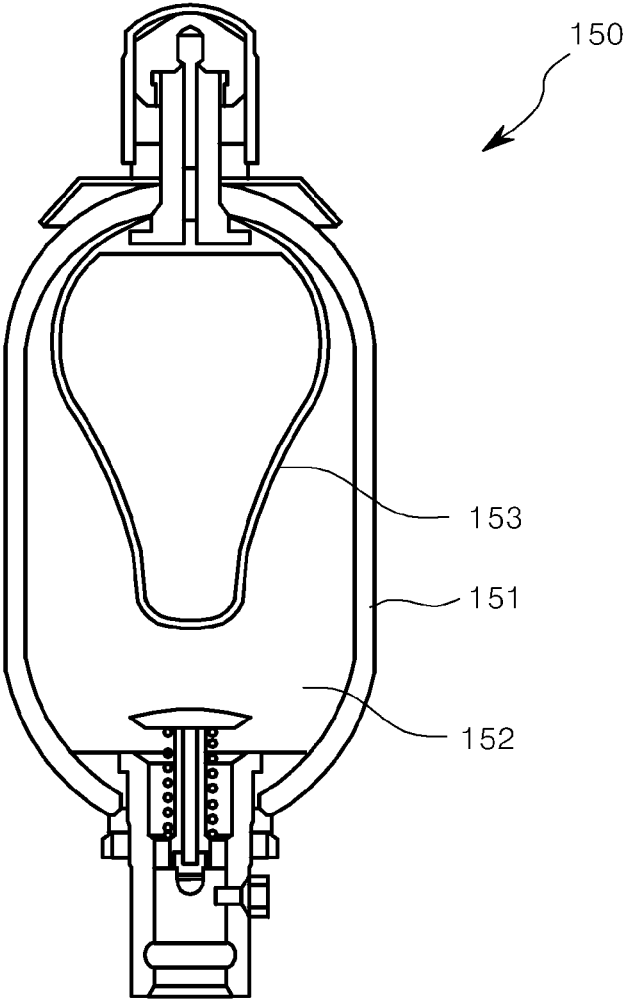

FIG. 11

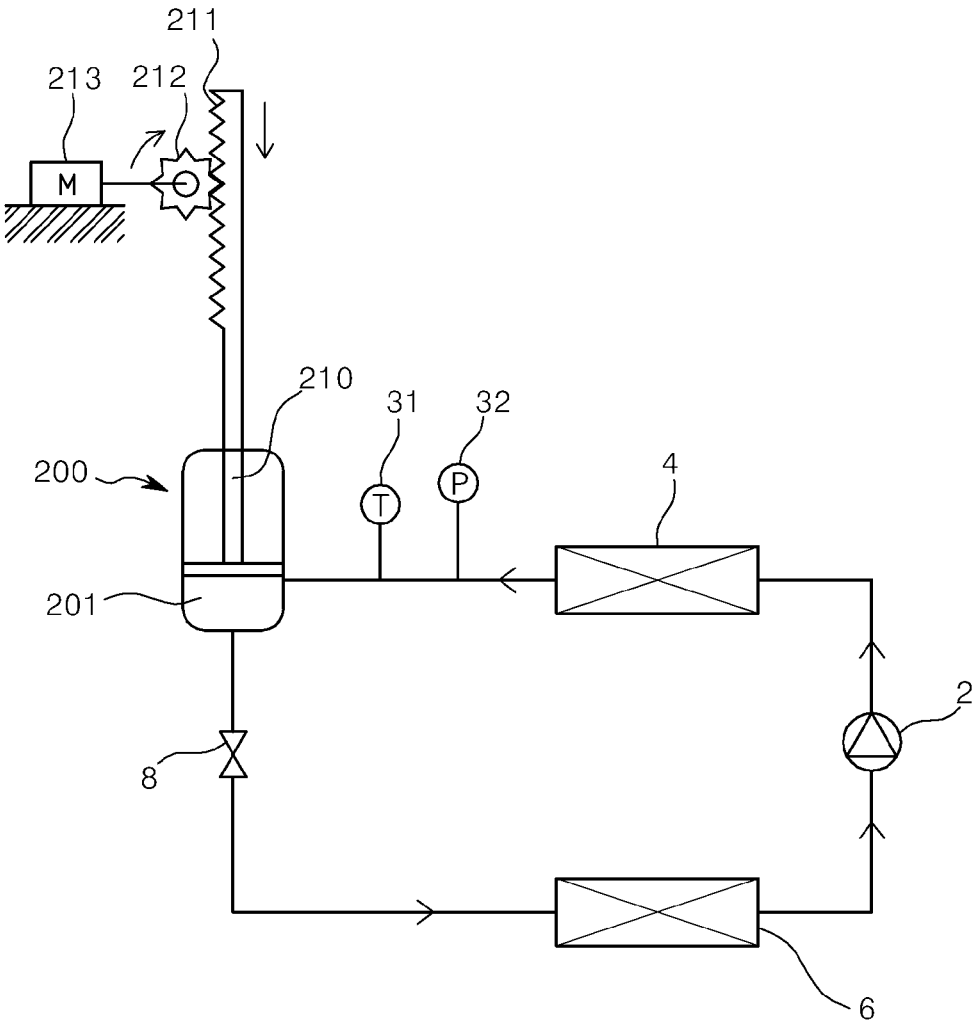
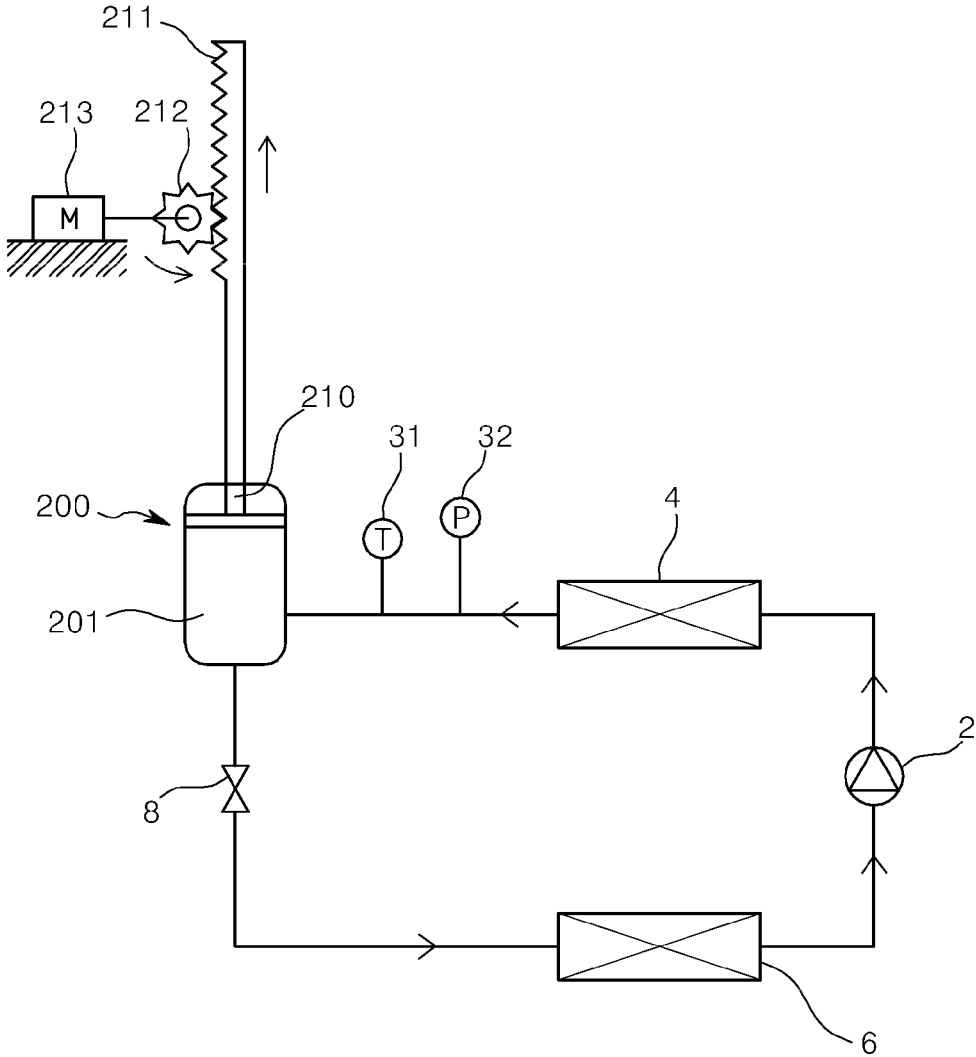

FIG. 12



**VARIABLE VOLUME RECEIVER FOR  
REFRIGERATING CYCLE, REFRIGERATING  
CYCLE COMPRISING THE VARIABLE  
RECEIVER, AND METHOD FOR  
CONTROLLING THE REFRIGERATING  
CYCLE**

TECHNICAL FIELD

**[0001]** The present invention relates to a variable volume receiver for a refrigerating cycle, a refrigerating cycle including the variable volume receiver, and a method for controlling the refrigerating cycle, and more particularly, to a variable volume receiver for a refrigerating cycle in which a proper degree of sub-cooling can be secured by changing the volume of a receiver according to driving conditions, thereby enabling optimum driving, a refrigerating cycle including the variable volume receiver, and a method for controlling the refrigerating cycle.

BACKGROUND ART

**[0002]** In general, driving conditions, such as an outside air temperature, change in various ways during driving of a refrigerating cycle. Thus, a proper amount of refrigerant required for cycle driving also changes. In this regard, a refrigerant filling amount is determined based on a case where a required proper amount is large, and when a surplus amount occurs during driving, the surplus amount is stored in a receiver. In this way, the receiver serves to cause the cycle to be stably driven in various conditions. However, a storable space of the receiver is pre-determined and thus, the receiver is selected to have enough space.

**[0003]** Meanwhile, an optimum degree of overheating and an optimum degree of sub-cooling that may maximize performance in given conditions respectively exist in the refrigerating cycle. The degree of overheating can be controlled using an electronic expansion valve or the like, but the degree of sub-cooling that is affected by the refrigerant filling amount is not generally controlled. In particular, in the case of a system to which the receiver is applied, the degree of sub-cooling cannot be actively controlled due to enough space of the receiver. Thus, driving in a state of an optimum degree of sub-cooling in which the performance of the cycle can be maximized, cannot be guaranteed.

**[0004]** Meanwhile, in Prior-art patent JP 2550632, the volume of a refrigerant storing space inside the receiver is increased directly using a refrigerant that is circulated in the refrigerating cycle. However, when a refrigerant at a discharging side of a compressor is used, a control operation for reducing the volume of a variable capacity body is not smoothly performed, and when a refrigerant at a suction side of the compressor is used, a control operation for increasing the volume of the variable capacity body is not smoothly performed. Since a refrigerant that is circulated in the refrigerating cycle is directly used, there is a possibility that a refrigerating capacity will be reduced. Thus, in actuality, there is a very large limitation in utility.

DETAILED DESCRIPTION OF THE INVENTION

Technical Problem

**[0005]** The present invention provides a variable volume receiver for a refrigerating cycle in which the amount of a refrigerant that may be stored can be controlled according to

driving conditions so that a degree of sub-cooling of a cycle can be actively controlled and optimum driving can be performed, a refrigerating cycle including the variable volume receiver, and a method for controlling the refrigerating cycle

Technical Solution

**[0006]** According to an aspect of the present invention, there is provided a variable volume receiver for a refrigerating cycle, including: a receiver tank that is connected to a refrigerant flow path and constitutes a refrigerant storing space in which the refrigerant that passes through the refrigerant flow path is temporarily stored; a variable bladder that is disposed in the receiver tank and is contracted or expanded so that a volume of the refrigerant storing space is reduced or decreased; a pressure-controlling portion that is installed separately from the refrigerant flow path, communicates with the variable bladder, is sealed from an outside and controls pressure in the variable bladder when a fluid that communicates with the variable bladder and is filled in the variable bladder receives heat of the refrigerant at an outlet of a compressor in the refrigerating cycle; and a controller that controls the pressure-controlling portion according to driving conditions, changes the volume of the refrigerant storing space and controls an amount of the refrigerant that is capable of being stored in the refrigerant storing space.

**[0007]** According to another aspect of the present invention, there is provided a variable volume receiver for a refrigerating cycle, including: a receiver tank that is connected to a refrigerant flow path and constitutes a refrigerant storing space in which the refrigerant that passes through the refrigerant flow path is temporarily stored; a piston that is coupled to the receiver tank so as to linearly make a reciprocating motion and increases or reduces a volume of the refrigerant storing space while linearly making a reciprocating motion; a linearly moving mechanism that linearly makes a reciprocating motion of the piston; and a controller that controls the linearly moving mechanism according to driving conditions, changes the volume of the refrigerant storing space and controls an amount of the refrigerant that is capable of being stored in the refrigerant storing space.

**[0008]** According to still another aspect of the present invention, there is provided a refrigerating cycle including a compressor, a condenser, an expansion mechanism, an evaporator, and a controller, further including a variable volume receiver, wherein the variable volume receiver includes a refrigerant storing portion which is installed on a refrigerant flow path that connects the condenser and the expansion mechanism and in which a refrigerant discharged from the condenser is temporarily stored, and a volume-controlling portion controls a volume of the refrigerant storing portion while being contracted or expanded by a pressure-controlling portion that is installed separately from the refrigerant flow path and sealed from an outside, and the controller controls pressure of a fluid in the volume-controlling portion according to driving conditions, changes the volume of the refrigerant storing portion and controls an amount of the refrigerant stored in the variable volume receiver.

**[0009]** According to still another aspect of the present invention, there is provided a refrigerating cycle including a compressor, a condenser, an expansion mechanism, an evaporator, and a controller, further including a variable volume receiver, wherein the variable volume receiver includes a receiver tank that is installed on a refrigerant flow path that connects the condenser and the expansion mechanism and

constitutes a refrigerant storing space in which a refrigerant discharged from the condenser is temporarily stored, a variable bladder that is disposed in the receiver tank and reduces or increases a volume of the refrigerant storing space while being contracted or expanded, and a pressure-controlling portion that is installed separately from the refrigerant flow path, communicates with the variable bladder, is sealed from an outside and controls pressure in the variable bladder when a fluid filled in the variable bladder receives heat of the refrigerant at an outlet of the compressor, and the controller calculates a degree of sub-cooling according to temperature and pressure of the refrigerant at an outlet of the condenser and controls the pressure-controlling portion according to the calculated degree of sub-cooling.

**[0010]** According to still another aspect of the present invention, there is provided a refrigerating cycle including a compressor, a condenser, an expansion mechanism, an evaporator, and a controller, further including a variable volume receiver, wherein the variable volume receiver includes a receiver tank that is connected to a refrigerant flow path and constitutes a refrigerant storing space in which a refrigerant that passes through the refrigerant flow path is temporarily stored, a piston that is coupled to the receiver tank so as to linearly make a reciprocating motion and increases or reduces a volume of the refrigerant storing space while linearly making a reciprocating motion, and a linearly moving mechanism that linearly makes a reciprocating motion of the piston, and the controller calculates a degree of sub-cooling according to temperature and pressure of the refrigerant at an outlet of the condenser and controls the linearly moving mechanism according to the calculated degree of sub-cooling.

**[0011]** According to still another aspect of the present invention, there is provided a method for controlling a refrigerating cycle, including: a degree of sub-cooling calculating operation of calculating a degree of sub-cooling by measuring temperature and pressure of a refrigerant at an outlet of a condenser; and a volume-controlling operation of increasing or reducing a volume of a refrigerant storing portion of a variable volume receiver according to the calculated degree of sub-cooling by controlling pressure of a fluid filled in a volume-controlling portion of the variable volume receiver using heat of the refrigerant at an outlet of a compressor, wherein the volume-controlling operation includes: if the calculated degree of sub-cooling is equal to or greater than a predetermined degree of sub-cooling, preventing heat of the refrigerant at the outlet of the compressor from being transferred to the fluid filled in the volume-controlling portion, thereby reducing pressure in the volume-controlling portion and increasing the volume of the refrigerant storing portion; and if the calculated degree of sub-cooling is less than the predetermined degree of sub-cooling, increasing pressure in the volume-controlling portion and reducing the volume of the refrigerant storing portion when the fluid filled in the volume-controlling portion receives heat of the refrigerant at the outlet of the compressor.

#### Effects of the Invention

**[0012]** A variable volume receiver for a refrigerating cycle according to the present invention can control the capacity for storing a refrigerant according to changes in driving conditions, such as an outside air temperature or a load-side temperature, and can secure a proper degree of sub-cooling even when the driving conditions change, thereby enabling opti-

imum driving regardless of changes in the outside air temperature or the load-side temperature.

**[0013]** In addition, the variable volume receiver for the refrigerating cycle according to the present invention is configured to expand a variable bladder by increasing a fluid pressure in a pressure-controlling pipe using heat of a high-temperature refrigerant discharged from a compressor. Thus, an additional heat source or mechanism for increasing the fluid pressure in the pressure-controlling pipe is not required.

**[0014]** Furthermore, the variable volume receiver for the refrigerating cycle according to the present invention uses an additional fluid without using the refrigerant that is circulated in the refrigerating cycle when the variable bladder is contracted or expanded, so that all amounts of the refrigerant discharged from the compressor can be introduced into a condenser without any loss.

#### DESCRIPTION OF THE DRAWINGS

**[0015]** FIG. 1 is a view of a state in which the volume of a refrigerant storing portion is increased, in a refrigerating cycle according to a first embodiment of the present invention;

**[0016]** FIG. 2 is a view of a state in which the volume of the refrigerant storing portion is reduced, in the refrigerating cycle illustrated in FIG. 1;

**[0017]** FIG. 3 is a view of an operation of a heat-exchanging portion illustrated in FIGS. 1 and 2;

**[0018]** FIG. 4 is a control block diagram of the refrigerating cycle illustrated in FIG. 1;

**[0019]** FIG. 5 is a control flowchart of the refrigerating cycle illustrated in FIG. 1;

**[0020]** FIG. 6 is a view of an operation of a heat-exchanging portion according to a second embodiment of the present invention;

**[0021]** FIG. 7 is a view of a state in which the volume of the refrigerant storing portion is increased, in a refrigerating cycle according to a third embodiment of the present invention;

**[0022]** FIG. 8 is a view of a state in which the volume of the refrigerant storing portion is reduced, in the refrigerating cycle illustrated in FIG. 7;

**[0023]** FIG. 9 is a control block diagram of the refrigerating cycle illustrated in FIG. 7;

**[0024]** FIG. 10 is a modified example of a variable volume receiver illustrated in FIG. 7;

**[0025]** FIG. 11 is a view of a state in which the volume of the refrigerant storing portion is reduced, in a refrigerating cycle according to a fifth embodiment of the present invention; and

**[0026]** FIG. 12 is a view of a state in which the volume of the refrigerant storing portion is increased, in the refrigerating cycle illustrated in FIG. 11.

#### MODE OF THE INVENTION

**[0027]** Hereinafter, a refrigerating cycle including a variable volume receiver according to embodiments of the present invention will be described.

**[0028]** FIG. 1 is a view of a state in which the volume of a refrigerant storing portion is increased, in a refrigerating cycle according to a first embodiment of the present invention. FIG. 2 is a view of a state in which the volume of the refrigerant storing portion is reduced, in the refrigerating cycle illustrated in FIG. 1. FIG. 3 is a view of an operation of

a heat-exchanging portion illustrated in FIGS. 1 and 2. FIG. 4 is a control block diagram of the refrigerating cycle illustrated in FIG. 1.

[0029] Referring to FIGS. 1 and 2, the refrigerating cycle according to the first embodiment of the present invention includes a compressor 2, a condenser 4, a variable volume receiver 10, an expansion valve 8, and an evaporator 6.

[0030] The variable volume receiver 10 is installed on a refrigerant flow path that connects the condenser 4 and the expansion valve 8. The variable volume receiver 10 includes a receiver tank that constitutes a refrigerant storing portion 12 in which a refrigerant at an outlet of the condenser 4 is temporarily stored, a variable bladder 14 that is disposed in the receiver tank and is contracted or expanded, and a pressure-controlling portion that controls a pressure of a fluid filled in the pressure-controlling pipe 20 that will be described later, so as to contract or expand the variable bladder 14.

[0031] The receiver tank is connected to the refrigerant flow path, temporarily stores a liquid refrigerant discharged from the condenser 4 and then sends the liquid refrigerant to the expansion valve 8.

[0032] A bladder that is a synthetic rubber bag having good elasticity is used as the variable bladder 14, and the variable bladder 14 is connected to the pressure-controlling pipe 20. The variable bladder 14 is expanded when the pressure of the fluid in the pressure-controlling pipe 20 is increased, and is contracted when the pressure of the fluid in the pressure-controlling pipe 20 is decreased. When the variable bladder 14 is contracted, a portion of the variable bladder 14 in the receiver tank is reduced so that the volume of the refrigerant storing portion 12 is increased. When the variable bladder 14 is expanded, the portion of the variable bladder 14 in the receiver tank is increased so that the volume of the refrigerant storing portion 12 is reduced.

[0033] The pressure-controlling portion is installed separately from the refrigerant flow path. The pressure-controlling portion communicates with the variable bladder 14 and is sealed from the outside. The pressure-controlling portion controls a pressure of the variable bladder 14 when the fluid filled in the pressure-controlling portion receives heat of the refrigerant at an outlet of the compressor 2, is evaporated and expanded. The pressure-controlling portion includes a heat-exchanging portion 40 installed at a discharge side of the compressor 2 and the pressure-controlling pipe 20 that transfers the pressure of the fluid in a heat-exchanging pipe 21 that will be described later to the variable bladder 14. The same refrigerant as the refrigerant that is circulated in the refrigerating cycle may also be used as the fluid, and a fluid having a larger volume expansion coefficient than that of the refrigerant may also be used as the fluid. When the volume expansion coefficient of the fluid is large, contraction or expansion of the fluid is well performed by heat exchanging so that contraction or expansion of the variable bladder 14 in which the fluid is filled, can also be well performed.

[0034] The heat-exchanging portion 40 includes a discharging pipe 41 of the compressor 2, the pressure-controlling pipe 20, and a linearly moving mechanism. Heat-exchanging between the discharging pipe 41 and the pressure-controlling pipe 20 is performed by the heat-exchanging portion 40.

[0035] The discharging pipe 41 of the compressor 2 is provided to pass through the heat-exchanging portion 40. The refrigerant that is compressed by the compressor 2 at a high

temperature under a high pressure passes through the discharging pipe 41 of the compressor 2.

[0036] The pressure-controlling pipe 20 includes the heat-exchanging pipe 21 and a capillary tube 22. All sections of the pressure-controlling pipe 20 are configured of the capillary tube 22 except for a portion of the pressure-controlling pipe 20 connected to the discharging portion 41 of the compressor 2 and a portion that communicates with the variable bladder 14. The capillary tube 22 accelerates a pressure transfer speed, and an inside of the pressure-controlling pipe 20 is in a two-phase state, i.e., in a state in which both a liquid fluid and a vapor fluid exist. The liquid fluid is concentrated on the heat-exchanging pipe 21. When the liquid fluid is in contact with the discharging pipe 41, the liquid fluid is evaporated and expanded by receiving heat of the high-temperature refrigerant that flows in the discharging pipe 41.

[0037] The linearly moving mechanism adjusts a distance between the heat-exchanging pipe 21 and the discharging pipe 41 of the compressor 2. The linearly moving mechanism linearly moves the heat-exchanging pipe 21 to be in contact with or spaced apart from the discharging pipe 41 of the compressor 2. The linearly moving mechanism includes a rack 24 coupled to the heat-exchanging pipe 21, a pinion 26 engaged with the rack 24, and a motor 28 that rotates the pinion 26. The rack 24 is coupled to one side of the heat-exchanging pipe 21 and linearly moves when the pinion 26 is rotated by driving the motor 28.

[0038] In this way, in the present embodiment, the rack 24 is coupled to the heat-exchanging pipe 21. However, embodiments of the present invention are not limited thereto, and the pinion 26 may also be coupled to the heat-exchanging pipe 21. Also, in the present embodiment, the position of the discharging pipe 41 is fixed, and the heat-exchanging pipe 21 is linearly moved. However, embodiments of the present invention are not limited thereto, and the position of the heat-exchanging pipe 21 may be fixed, and the discharging pipe 41 may be linearly moved, or both the heat-exchanging pipe 21 and the discharging pipe 41 may be linearly moved.

[0039] A motor that may be bidirectionally rotated is used as the motor 28, and a rotation direction of the motor 28 changes according to signals of a controller 60.

[0040] The refrigerating cycle further includes a temperature sensor 31 that measures temperature T of the refrigerant at an outlet of the condenser 4 and a pressure sensor 32 that measures pressure P of the refrigerant at the outlet of the condenser 4.

[0041] The controller 60 calculates a degree of sub-cooling according to values detected by the temperature sensor 31 and the pressure sensor 32, compares the calculated degree of sub-cooling with a predetermined range of sub-cooling and controls an operation of the motor 28 according to the result of comparison. In the present embodiment, the controller 60 controls the operation of the motor 28 according to the degree of sub-cooling. However, embodiments of the present invention are not limited thereto, and the controller 60 may control the operation of the motor 28 according to an outside air temperature or other driving conditions, thereby adjusting the volume of the variable volume receiver 10.

[0042] A method for controlling the refrigerating cycle having the above configuration according to a first embodiment of the present invention will be described as below.

[0043] Referring to FIG. 5, the temperature T and the pressure P of the refrigerant at the outlet of the condenser 4 are measured (S1). The temperature sensor 31 measures the tem-



perature T of the refrigerant at the outlet of the condenser 4, and the pressure sensor 32 measures the pressure P of the refrigerant at the outlet of the condenser 4. A saturation temperature  $T_{sat}$  can be known from the pressure P of the refrigerant measured by the pressure sensor 32 (S2).

[0044] By calculating a difference between the saturation temperature  $T_{sat}$  of the refrigerant and the measured temperature T, a degree of sub-cooling can be calculated (S3). It is compared whether a value of the calculated degree of sub-cooling is equal to a value of a predetermined degree of sub-cooling (S4). If the two values are different from each other, the pressure-controlling portion is controlled so that the variable bladder 14 is contracted or expanded and thus, the volume of the refrigerant storing portion 12 is reduced or increased (S5). Changes in the volume of the refrigerant storing portion 12 change a substantial filling amount of a cycle defined as the sum of the compressor 2, the condenser 4, the expansion valve 8, the evaporator 6, and the amount of the refrigerant filled in a connection pipe thereof, except for the amount of the refrigerant stored in the variable volume receiver 10. This finally causes changes in the degree of sub-cooling and thus, the degree of sub-cooling can be controlled by controlling the pressure-controlling portion.

[0045] In this case, if the calculated degree of sub-cooling is equal to or greater than the predetermined degree of sub-cooling, it is determined that the substantial filling amount is larger than an optimum filling amount. Thus, the volume of the variable bladder 14 in the variable volume receiver 10 is reduced, and the amount of the refrigerant stored in the refrigerant storing portion 12 is increased by increasing the volume of the refrigerant storing portion 12.

[0046] Referring to FIGS. 2 and 3(a), in order to reduce the volume of the variable bladder 14, the discharging pipe 41 of the compressor 2 and the heat-exchanging pipe 21 are spaced apart from each other so that heat-exchanging is not performed by the heat-exchanging portion 40. When the motor 28 is rotated clockwise, the rack 24 moves backward, and the heat-exchanging pipe 21 is spaced apart from the discharging pipe 41. When the heat-exchanging pipe 21 and the discharging pipe 41 are spaced apart from each other, the fluid in the heat-exchanging pipe 21 does not receive heat from the discharging pipe 41, and the fluid in the pressure-controlling pipe 20 is maintained in a room temperature state. Since the fluid in the room temperature state is a two-phase fluid in which a liquid phase and a vapor phase are mixed with each other and has a lower pressure than that of the refrigerant at the outlet of the condenser 4, a pressure in the variable bladder 14 is reduced, and the variable bladder 14 is contracted. When the variable bladder 14 is contracted, the volume of the refrigerant storing portion 12 is relatively increased. Thus, the amount of the refrigerant that may be stored in the variable volume receiver 10 is increased. When the amount of the refrigerant stored in the variable volume receiver 10 is increased, the substantial filling amount in the refrigerating cycle is reduced, and the amount of the refrigerant in the condenser 4 is also reduced. Thus, the degree of sub-cooling of the refrigerant is reduced and is adjusted in the range of the predetermined degree of sub-cooling.

[0047] Meanwhile, when the calculated degree of sub-cooling is less than the predetermined degree of sub-cooling, it is determined that the substantial filling amount in the refrigerating cycle should be increased. Thus, the volume of the variable bladder 14 in the variable volume receiver 10 is increased, and the volume of the refrigerant storing portion 12

is reduced so that the amount of the refrigerant stored in the refrigerant storing portion 12 can be reduced.

[0048] Referring to FIGS. 1 and 3(b), in order to increase the volume of the variable bladder 14, the discharging pipe 41 of the compressor 2 and the heat-exchanging pipe 21 are in contact with each other so that heat-exchanging is performed by the heat-exchanging portion 40. When the motor 28 is rotated counterclockwise, the rack 24 moves forward, and the heat-exchanging pipe 21 moves forward toward the discharging pipe 41 and thus is in contact with the discharging pipe 41. When the heat-exchanging pipe 21 and the discharging pipe 41 are in contact with each other, the fluid in the heat-exchanging pipe 21 receives heat from the high-temperature refrigerant that passes through the discharging pipe 41. Due to heat transferred from the discharging pipe 41, a temperature of the fluid in the pressure-controlling pipe 20 rises, and the liquid fluid is evaporated so that a proportion of the vapor fluid in the entire fluid is increased. Thus, temperature and pressure in the pressure-controlling pipe 20 are increased, and the pressure in the variable bladder 14 is increased so that the variable bladder 14 is expanded. When the variable bladder 14 is expanded and its volume is increased, the volume of the refrigerant storing portion 12 is relatively reduced. The volume of the refrigerant storing portion 12 is reduced and the amount of the refrigerant that may be stored in the variable volume receiver 10 is reduced, the substantial filling amount is increased, and the amount of the refrigerant in the condenser 4 is increased so that the degree of sub-cooling of the refrigerant is increased.

[0049] As described above, the volume of the variable bladder 14 is contracted or expanded so that the volume of the refrigerant storing portion 12 can be reduced or increased. Thus, the degree of sub-cooling of the refrigerant can be adjusted in a predetermined range.

[0050] FIG. 6 is a view of an operation of a heat-exchanging portion according to a second embodiment of the present invention.

[0051] Referring to FIG. 6, the heat-exchanging portion according to the second embodiment of the present invention is different from the heat-exchanging portion according to the first embodiment in that a sheet 50 that linearly makes a reciprocating motion between the discharging pipe 41 of the compressor 2 and the heat-exchanging pipe 21 is installed. The difference will be described in detail.

[0052] The sheet 50 may be an insulating sheet that insulates a space between the discharging pipe 41 and the heat-exchanging pipe 21 or a heat transfer sheet that transfers heat of the discharging pipe 41 to the heat-exchanging pipe 21. In the present embodiment, the sheet 50 is the insulating sheet that insulates the space between the discharging pipe 41 and the heat-exchanging pipe 21.

[0053] The heat-exchanging portion further includes a linearly moving mechanism that linearly makes a reciprocating motion of the sheet 50 between the discharging pipe 41 and the heat-exchanging pipe 21. The linearly moving mechanism includes a rack 51 that is formed integrally with the sheet 50 or coupled to the sheet 50, a pinion 42 engaged with the rack 51, and a motor 53 that rotates the pinion 42. However, embodiments of the present invention are not limited thereto, and of course, the pinion 42 may be coupled to the rack 51.

[0054] When the discharging pipe 41 and the heat-exchanging pipe 21 are heat-exchanged, the heat-exchanging portion having the above configuration rotates the motor 53

counterclockwise and moves the sheet 50 downward, as illustrated in FIG. 6(b). The heat-exchanging pipe 21 is provided to have elasticity in a direction of the discharging pipe 41 so that the heat-exchanging pipe 21 and the discharging pipe 41 are in contact with each other and thus heat-exchanging is performed. The fluid in the heat-exchanging pipe 21 receives heat from the discharging pipe 41 and is evaporated and expanded, thereby expanding the variable bladder 14.

[0055] Meanwhile, when the discharging pipe 41 and the heat-exchanging pipe 21 are not heat-exchanged, as illustrated in FIG. 6(b), the motor 53 is rotated clockwise. When the motor 53 is rotated clockwise, the sheet 50 is moved upward and is inserted into a space between the discharging pipe 41 and the heat-exchanging pipe 21 so that heat of the discharging pipe 41 can be prevented from being transferred to the heat-exchanging pipe 21. When heat is not transferred to the heat-exchanging pipe 21, the fluid in the heat-exchanging pipe 21 is cooled and contracted so that the variable bladder 14 is also contracted.

[0056] FIG. 7 is a view of a state in which the volume of the refrigerant storing portion is increased, in a refrigerating cycle according to a third embodiment of the present invention. FIG. 8 is a view of a state in which the volume of the refrigerant storing portion is reduced, in the refrigerating cycle illustrated in FIG. 7. FIG. 9 is a control block diagram of the refrigerating cycle illustrated in FIG. 7.

[0057] Referring to FIGS. 7 and 8, the refrigerating cycle according to the third embodiment of the present invention further includes a refrigerant bypass flow path 110, a bypass valve 112, a heat-exchanging portion 100, and a pressure-controlling pipe 20.

[0058] On the bypass flow path 110, the refrigerant discharged from the discharging pipe of the compressor 2 is bypassed toward the heat-exchanging portion 100. A check valve 116 is installed at an outlet of the bypass flow path 110.

[0059] The bypass valve 112 is a valve that opens/closes the bypass flow path 110 according to signals of a controller 120.

[0060] A flow rate regulating valve 114 that opens/closes a flow path is installed at the discharging pipe of the compressor 2.

[0061] The heat-exchanging portion 100 performs heat-exchanging between the refrigerant bypassed on the bypass flow path 110 and the heat-exchanging pipe 21 of the pressure-controlling pipe 20.

[0062] The controller 120 calculates a degree of sub-cooling according to the temperature and pressure detected by the temperature sensor 31 and the pressure sensor 32, compares the calculated degree of sub-cooling with a predetermined degree of sub-cooling and controls the bypass valve 112 and the flow rate regulating valve 114 according to the result of comparison.

[0063] A difference between the method for controlling the refrigerating cycle having the above configuration according to the third embodiment of the present invention and that according to the first embodiment of the present invention will be described.

[0064] First, when the calculated degree of sub-cooling is equal to or greater than the predetermined degree of sub-cooling according to the temperature and pressure detected by the temperature sensor 31 and the pressure sensor 32, it is determined that the substantial filling amount in the cycle is larger than an optimum filling amount, and the volume of the refrigerant storing portion 12 of the variable volume receiver 10 is increased.

[0065] The controller 120 closes the bypass valve 112 and opens the flow rate regulating valve 114 so that the refrigerant discharged from the compressor 2 is not bypassed on the bypass flow path 110. Thus, since heat of the high-temperature refrigerant discharged from the compressor 2 is not transferred to the fluid in the heat-exchanging pipe 21, the fluid in the pressure-controlling pipe 20 is maintained in a room temperature state. Since the fluid in the room temperature state is a two-phase fluid in which a liquid phase and a vapor phase are mixed with each other and has a lower pressure than that of the refrigerant at the outlet of the condenser, pressure in the variable bladder 14 is also reduced, and the variable bladder 14 is contracted. When the variable bladder 14 is contracted, the volume of the refrigerant storing portion 12 is relatively increased. Thus, the amount of the refrigerant that may be stored in the variable volume receiver 10 is increased. When the amount of the refrigerant stored in the variable volume receiver 10 is increased, the substantial filling amount in the refrigerating cycle is reduced, and the amount of the refrigerant in the condenser 4 is also reduced. Thus, the degree of sub-cooling of the refrigerant is reduced.

[0066] Thus, when the calculated degree of sub-cooling is higher than the predetermined degree of sub-cooling, the degree of sub-cooling of the refrigerant may be reduced and adjusted to the predetermined degree of sub-cooling.

[0067] Meanwhile, when the calculated degree of sub-cooling is less than the predetermined degree of sub-cooling, it is determined that the substantial filling amount is insufficient compared to the optimum filling amount, and the volume of the refrigerant storing portion 12 of the variable volume receiver 10 is reduced.

[0068] The controller 120 opens the bypass valve 112 and closes the flow rate regulating valve 114. The refrigerant discharged from the compressor 2 is bypassed on the bypass flow path 110, and heat of the high-temperature refrigerant discharged from the compressor 2 is transferred to the fluid. Due to heat transferred from the discharging pipe 41, temperature of the fluid in the pressure-controlling pipe 20 is increased, and a proportion of the vapor fluid in the entire fluid is increased when the liquid fluid is evaporated. Thus, the temperature and pressure in the pressure-controlling pipe 20 are increased, and the pressure in the variable bladder 14 is also increased so that the variable bladder 14 is expanded. When the variable bladder 14 is expanded and the volume of the variable bladder 14 is increased, the volume of the refrigerant storing portion 12 is relatively reduced. When the volume of the refrigerant storing portion 12 is reduced and the amount of the refrigerant that may be stored in the variable volume receiver 10 is reduced, the substantial filling amount is increased, and the amount of the refrigerant in the condenser 4 is increased, and the degree of sub-cooling of the refrigerant is increased.

[0069] Thus, when the calculated degree of sub-cooling is less than the predetermined degree of sub-cooling, the degree of sub-cooling of the refrigerant may be increased and adjusted to the predetermined degree of sub-cooling, as described above.

[0070] Meanwhile, as illustrated in FIG. 10, a variable bladder type accumulator 150 may be used as the variable volume receiver. The variable bladder type accumulator has a structure in which a variable bladder 153 that is a synthetic rubber bag is installed at an upper side of an inside of a pressure tank 151 and a fluid in the pressure tank 151 and a fluid in the variable bladder 153 are spaced apart from each

other. When the variable bladder 153 is contracted or expanded, the volume of an internal space 152 of the pressure tank is increased or reduced.

[0071] Meanwhile, a linearly moving mechanism of a variable volume receiver according to a fourth embodiment of the present invention is different from that according to the third embodiment of the present invention in that the linearly moving mechanism of the fourth embodiment of the present invention includes a magnetic body (not shown) installed at one of the pressure-controlling pipe 20 and the discharging pipe 41 of the compressor 2, an electromagnet (not shown) installed at the other one thereof and a power supplying portion that applies power to the electromagnet (not shown) according to signals of the controller 120. Thus, the controller 120 applies or blocks power to or from the electromagnet (not shown), thereby adjusting a distance between the pressure-controlling pipe 20 and the discharging pipe 41 of the compressor 2 so that the pressure of the fluid in the pressure-controlling pipe 20 can be increased or reduced using heat of the discharging pipe 41 of the compressor 2.

[0072] FIG. 11 is a view of a state in which the volume of the refrigerant storing portion is reduced, in a refrigerating cycle according to a fifth embodiment of the present invention. FIG. 12 is a view of a state in which the volume of the refrigerant storing portion is increased, in the refrigerating cycle illustrated in FIG. 11.

[0073] Referring to FIGS. 11 and 12, a variable volume receiver 200 for a refrigerating cycle according to the fifth embodiment of the present invention includes a receiver tank in which a refrigerant storing portion 201 is formed, a piston 210, and a linearly moving mechanism.

[0074] The piston 210 is coupled to the receiver tank so as to linearly make a reciprocating motion, linearly makes a reciprocating motion and increases or reduces the volume of the refrigerant storing portion 201. A sealing member that prevents leakage of the refrigerant stored in the refrigerant storing portion 201 is installed between the piston 210 and the receiver tank.

[0075] The linearly moving mechanism linearly moves the piston 210. The linearly moving mechanism includes a rack 211 that is formed integrally with or couple to a rod of the piston 210, a pinion 212 engaged with the rack 211, and a motor 213 that rotates the pinion 212.

[0076] A difference between a method for controlling the refrigerating cycle having the above configuration and the method according to the first embodiment will be described.

[0077] First, when a calculated degree of sub-cooling is less than a predetermined degree of sub-cooling according to the temperature and pressure detected by the temperature sensor 31 and the pressure sensor 32, it is determined that the substantial filling amount is insufficient compared to an optimum filling amount, and the volume of the refrigerant storing portion 201 of the variable volume receiver 200 is reduced.

[0078] Referring to FIG. 11, when the pinion 212 is rotated clockwise, the rack 211 moves downward, and the piston 210 reduces the volume of the refrigerant storing portion 201. When the volume of the refrigerant storing portion 201 is reduced, the amount of the refrigerant that may be stored in the refrigerant storing portion 201 is reduced. When the amount of the refrigerant that may be stored in the refrigerant storing portion 201 is reduced, the substantial filling amount is increased, and the amount of the refrigerant in the condenser 4 is increased so that the degree of sub-cooling of the refrigerant is increased.

[0079] Thus, when the calculated degree of sub-cooling is less than the predetermined degree of sub-cooling, the degree of sub-cooling of the refrigerant may be increased and adjusted to the predetermined degree of sub-cooling, as described above.

[0080] Meanwhile, when the calculated degree of sub-cooling is equal to or greater than the predetermined degree of sub-cooling, it is determined that the substantial filling amount is larger than the optimum filling amount, and the volume of the refrigerant storing portion 201 of the variable volume receiver 200 is increased.

[0081] Referring to FIG. 12, when the pinion 212 is rotated counterclockwise, the rack 211 moves upward, and the piston 210 moves upward so that the volume of the refrigerant storing portion 201 is increased. When the volume of the refrigerant storing portion 201 is increased, the amount of the refrigerant that may be stored in the refrigerant storing portion 201 is increased. When the amount of the refrigerant that may be stored in the refrigerant storing portion 201 is increased, the substantial filling amount is reduced, and the amount of the refrigerant in the condenser 4 is reduced. Thus, the degree of sub-cooling of the refrigerant is reduced.

[0082] Thus, when the calculated degree of sub-cooling is higher than the predetermined degree of sub-cooling, the degree of sub-cooling of the refrigerant may be reduced and adjusted to the predetermined degree of sub-cooling, as described above.

[0083] While the present invention has been particularly shown and described with reference to exemplary embodiments thereof, it will be understood by those of ordinary skill in the art that various changes in form and details may be made therein without departing from the spirit and scope of the present invention as defined by the following claims.

#### INDUSTRIAL APPLICABILITY

[0084] According to the present invention, a variable volume receiver for a refrigerating cycle that enables optimum driving and the refrigerating cycle including the same can be manufactured.

1. A variable volume receiver for a refrigerating cycle, comprising:

a receiver tank that is connected to a refrigerant flow path and constitutes a refrigerant storing space in which the refrigerant that passes through the refrigerant flow path is temporarily stored;

a variable bladder that is disposed in the receiver tank and is contracted or expanded so that a volume of the refrigerant storing space is reduced or decreased;

a pressure-controlling portion that is installed separately from the refrigerant flow path, communicates with the variable bladder, is sealed from an outside and controls pressure in the variable bladder when a fluid that communicates with the variable bladder and is filled in the variable bladder receives heat of the refrigerant at an outlet of a compressor in the refrigerating cycle; and

a controller that controls the pressure-controlling portion according to driving conditions, changes the volume of the refrigerant storing space and controls an amount of the refrigerant that is capable of being stored in the refrigerant storing space.

2. A variable volume receiver for a refrigerating cycle, comprising:

a receiver tank that is connected to a refrigerant flow path and constitutes a refrigerant storing space in which the refrigerant that passes through the refrigerant flow path is temporarily stored;

a piston that is coupled to the receiver tank so as to linearly make a reciprocating motion and increases or reduces a volume of the refrigerant storing space while linearly making a reciprocating motion;

a linearly moving mechanism that linearly makes a reciprocating motion of the piston; and

a controller that controls the linearly moving mechanism according to driving conditions, changes the volume of the refrigerant storing space and controls an amount of the refrigerant that is capable of being stored in the refrigerant storing space.

3. A refrigerating cycle comprising a compressor, a condenser, an expansion mechanism, an evaporator, and a controller, further comprising a variable volume receiver, wherein the variable volume receiver comprises a refrigerant storing portion which is installed on a refrigerant flow path that connects the condenser and the expansion mechanism and in which a refrigerant discharged from the condenser is temporarily stored, and a volume-controlling portion controls a volume of the refrigerant storing portion while being contracted or expanded by a pressure-controlling portion that is installed separately from the refrigerant flow path and sealed from an outside, and

the controller controls pressure of a fluid in the volume-controlling portion according to driving conditions, changes the volume of the refrigerant storing portion and controls an amount of the refrigerant stored in the variable volume receiver.

4. A refrigerating cycle comprising a compressor, a condenser, an expansion mechanism, an evaporator, and a controller, further comprising a variable volume receiver, wherein the variable volume receiver comprises a receiver tank that is installed on a refrigerant flow path that connects the condenser and the expansion mechanism and constitutes a refrigerant storing space in which a refrigerant discharged from the condenser is temporarily stored, a variable bladder that is disposed in the receiver tank and reduces or increases a volume of the refrigerant storing space while being contracted or expanded, and a pressure-controlling portion that is installed separately from the refrigerant flow path, communicates with the variable bladder, is sealed from an outside and controls pressure in the variable bladder when a fluid filled in the variable bladder receives heat of the refrigerant at an outlet of the compressor, and

the controller calculates a degree of sub-cooling according to temperature and pressure of the refrigerant at an outlet of the condenser and controls the pressure-controlling portion according to the calculated degree of sub-cooling.

5. A refrigerating cycle comprising a compressor, a condenser, an expansion mechanism, an evaporator, and a controller, further comprising a variable volume receiver, wherein the variable volume receiver comprises a receiver tank that is connected to a refrigerant flow path and constitutes a refrigerant storing space in which a refrigerant that passes through the refrigerant flow path is temporarily stored, a piston that is coupled to the receiver tank so as to linearly make a reciprocating motion and increases or reduces a volume of the refrigerant storing space while linearly making a

reciprocating motion, and a linearly moving mechanism that linearly makes a reciprocating motion of the piston, and

the controller calculates a degree of sub-cooling according to temperature and pressure of the refrigerant at an outlet of the condenser and controls the linearly moving mechanism according to the calculated degree of sub-cooling.

6. The refrigerating cycle of claim 4, wherein the pressure-controlling portion comprises a pressure-controlling pipe which communicates with the variable bladder and in which a fluid that is evaporated by receiving heat of a high-temperature refrigerant at the outlet of the compressor is filled.

7. The refrigerating cycle of claim 4, wherein the pressure-controlling portion comprises a pressure-controlling pipe which communicates with the variable bladder and in which the fluid is filled; and

a heat-exchanging portion that is installed at a discharging side of the compressor and performs or blocks heat-exchanging between the high-temperature refrigerant at the outlet of the compressor and the fluid of the pressure-controlling pipe according to signals of the controller.

8. The refrigerating cycle of claim 7, wherein the heat-exchanging portion comprises a linearly moving mechanism that linearly moves at least one of the discharging pipe of the compressor and the pressure-controlling pipe to be spaced apart from each other so that a distance between the discharging pipe of the compressor and the pressure-controlling pipe is adjusted according to signals of the controller.

9. The refrigerating cycle of claim 8, wherein the linearly moving mechanism comprises a rack coupled to the pressure-controlling pipe, a pinion engaged with the rack, and a motor that rotates the pinion according to signals of the controller.

10. The refrigerating cycle of claim 8, wherein the linearly moving mechanism comprises a magnetic body installed at one of the pressure-controlling pipe and the discharging pipe of the compressor, an electromagnet installed at the other one thereof, and a power supplying portion that applies power to the electromagnet according to signals of the controller.

11. The refrigerating cycle of claim 7, wherein the heat-exchanging portion comprises an insulating sheet that linearly makes a reciprocating motion between the discharging pipe of the compressor and the pressure-controlling pipe and prevents heat of the discharging pipe of the compressor from being transferred to the pressure-controlling pipe, and a linearly moving mechanism that linearly makes a reciprocating motion of the insulating sheet according to signals of the controller.

12. The refrigerating cycle of claim 7, wherein the heat-exchanging portion comprises a heat transfer sheet that linearly makes a reciprocating motion between the discharging pipe of the compressor and the pressure-controlling pipe according to signals of the controller and transfers heat of the discharging pipe of the compressor to the pressure-controlling pipe, and a linearly moving mechanism that linearly makes a reciprocating motion of the heat transfer sheet.

13. The refrigerating cycle of claim 4, wherein the pressure-controlling portion comprises:

a pressure-controlling pipe which communicates with the variable bladder and in which the fluid is filled;

a refrigerant bypass flow path on which the refrigerant at the outlet of the compressor is bypassed toward the pressure-controlling pipe; and

a bypass valve that opens/closes the refrigerant bypass flow path.

- 14. The refrigerating cycle of claim 7, wherein the pressure-controlling pipe comprises a capillary flow path.
- 15. The refrigerating cycle of claim 7, wherein the fluid is used the same refrigerant on the refrigerant flow path.
- 16. The refrigerating cycle of claim 7, wherein a volume expansion coefficient of the fluid filled in the pressure-controlling pipe and the variable bladder is equal to or greater than a volume expansion coefficient of the refrigerant.
- 17. A method for controlling a refrigerating cycle, comprising:
  - a degree of sub-cooling calculating operation of calculating a degree of sub-cooling by measuring temperature and pressure of a refrigerant at an outlet of a condenser; and
  - a volume-controlling operation of increasing or reducing a volume of a refrigerant storing portion of a variable volume receiver according to the calculated degree of sub-cooling by controlling pressure of a fluid filled in a volume-controlling portion of the variable volume receiver using heat of the refrigerant at an outlet of a compressor,

- wherein the volume-controlling operation comprises:
  - if the calculated degree of sub-cooling is equal to or greater than a predetermined degree of sub-cooling, preventing heat of the refrigerant at the outlet of the compressor from being transferred to the fluid filled in the volume-controlling portion, thereby reducing pressure in the volume-controlling portion and increasing the volume of the refrigerant storing portion; and
  - if the calculated degree of sub-cooling is less than the predetermined degree of sub-cooling, increasing pressure in the volume-controlling portion and reducing the volume of the refrigerant storing portion when the fluid filled in the volume-controlling portion receives heat of the refrigerant at the outlet of the compressor.
- 18. The refrigerating cycle of claim 13, wherein the pressure-controlling pipe comprises a capillary flow path.
- 19. The refrigerating cycle of claim 13, wherein the fluid is used the same refrigerant on the refrigerant flow path.
- 20. The refrigerating cycle of claim 13, wherein a volume expansion coefficient of the fluid filled in the pressure-controlling pipe and the variable bladder is equal to or greater than a volume expansion coefficient of the refrigerant.

\* \* \* \* \*