



US 20170149976A1

(19) **United States**

(12) **Patent Application Publication**
CONWAY et al.

(10) **Pub. No.: US 2017/0149976 A1**

(43) **Pub. Date: May 25, 2017**

(54) **ADAPTIVE OCCUPANCY REAL-TIME PREDICTIVE ROUTING**

continuation of application No. 14/049,082, filed on Oct. 8, 2013, now abandoned, which is a continuation of application No. 13/828,154, filed on Mar. 14, 2013, now Pat. No. 9,137,372.

(71) Applicant: **Mattersight Corporation**, Chicago, IL (US)

Publication Classification

(72) Inventors: **Kelly CONWAY**, Lake Bluff, IL (US); **David GUSTAFSON**, Lake Bluff, IL (US); **Douglas BROWN**, Austin, TX (US); **Michael Glen GATES**, Lakeway, TX (US); **William Duane SKEEN**, Austin, TX (US); **Brendan JOYCE**, Chicago, IL (US)

(51) **Int. Cl.**
H04M 3/523 (2006.01)
H04M 3/51 (2006.01)
(52) **U.S. Cl.**
CPC **H04M 3/5232** (2013.01); **H04M 3/5175** (2013.01); **H04M 2203/551** (2013.01)

(21) Appl. No.: **15/425,803**

(57) **ABSTRACT**

(22) Filed: **Feb. 6, 2017**

The methods, apparatus, and systems described herein are designed to route customer communications to the best agent or best available agent. The methods include receiving a customer communication, predicting a demographic profile of the customer associated with the customer communication, monitoring real-time agent performance data and modifying a predetermined work threshold based on the real-time agent performance data, and providing a routing recommendation to route the customer to an agent based on the prediction and historical customer data for agents who have not exceeded the predetermined work threshold.

Related U.S. Application Data

(63) Continuation of application No. 14/818,082, filed on Aug. 4, 2015, now Pat. No. 9,565,312, which is a continuation of application No. 14/518,423, filed on Oct. 20, 2014, now Pat. No. 9,137,373, which is a continuation of application No. 14/090,949, filed on Nov. 26, 2013, now Pat. No. 8,867,733, which is a

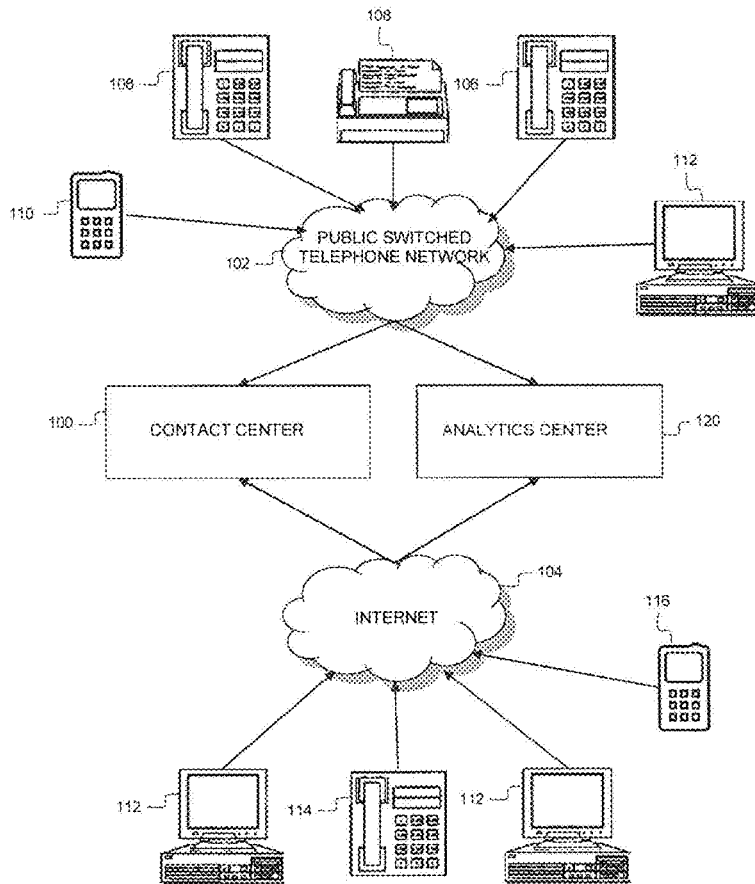

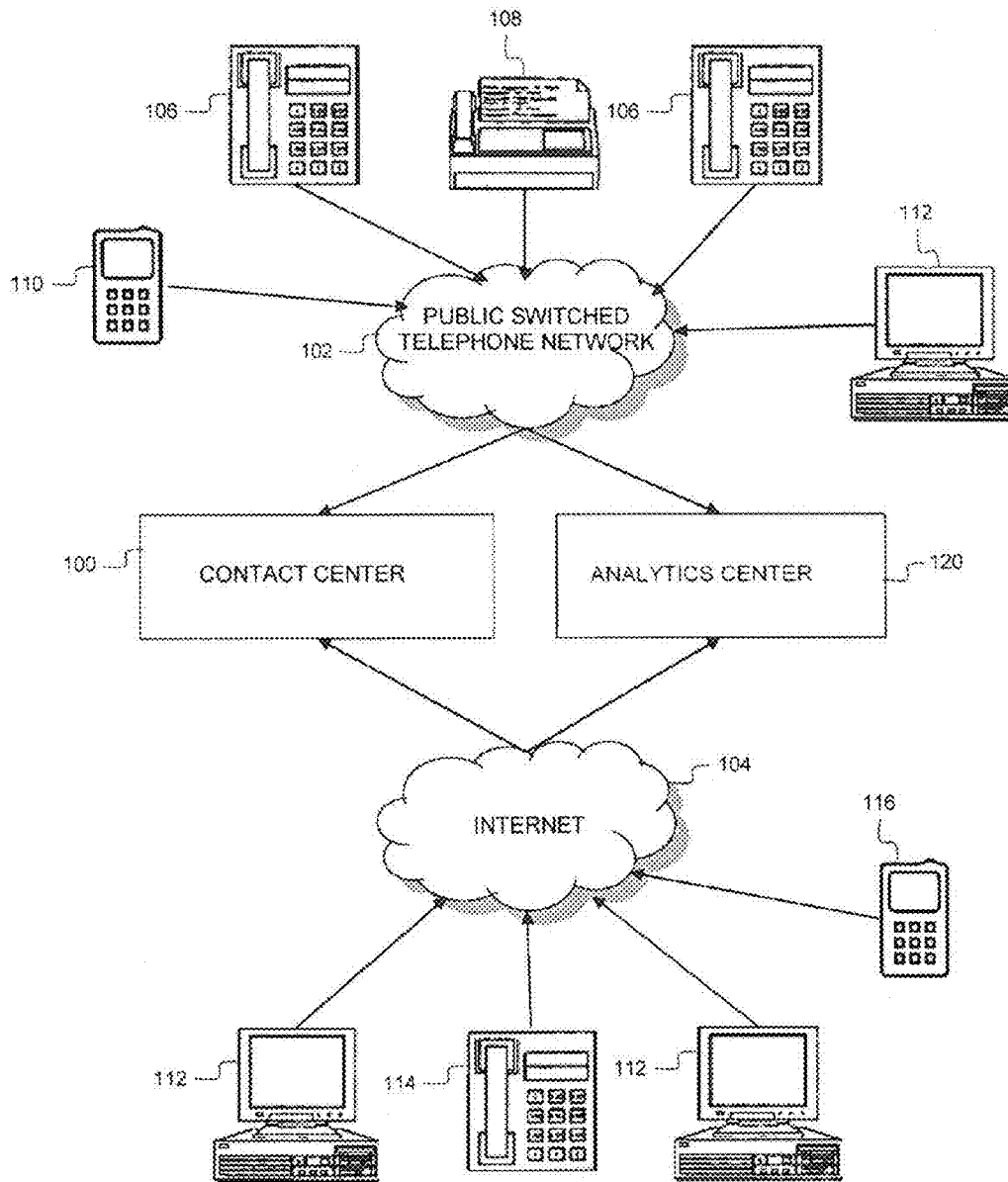

FIG. 1

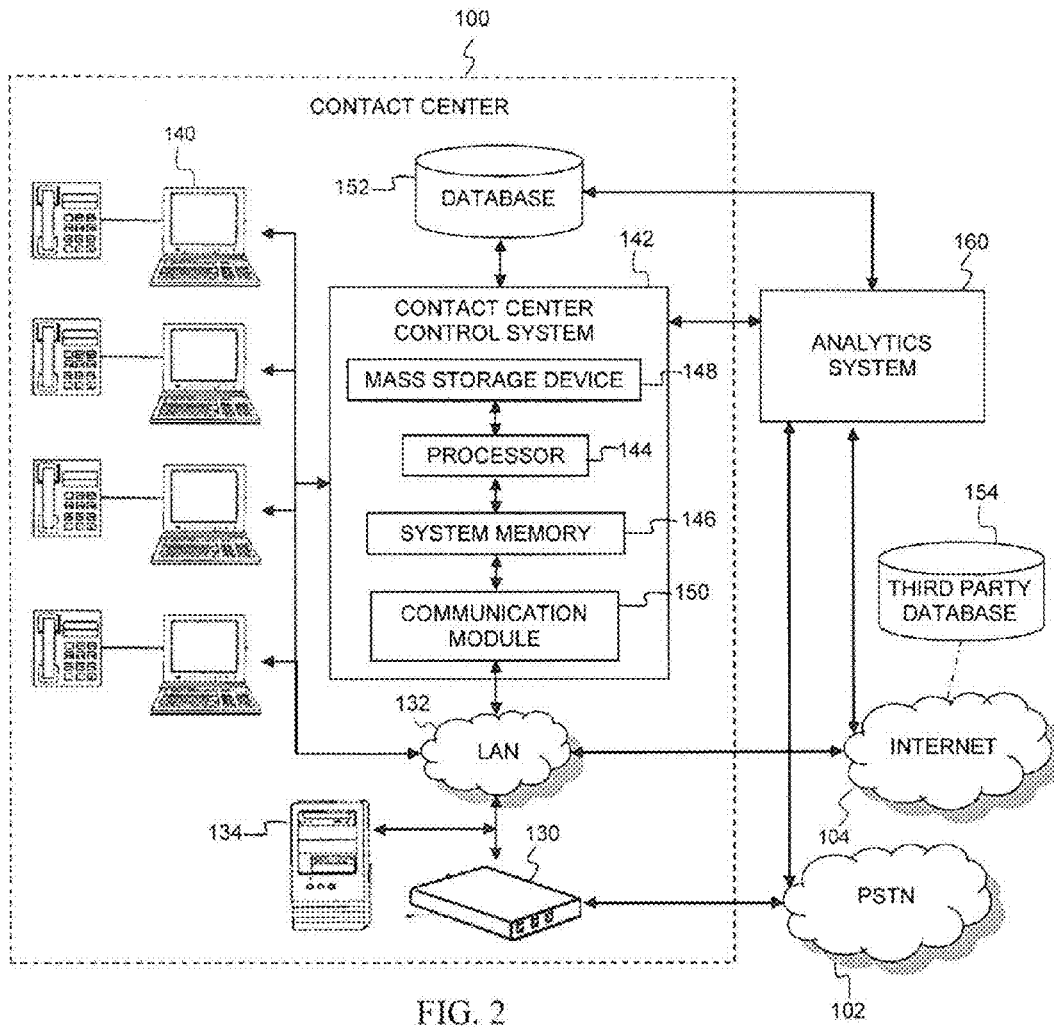

FIG. 2

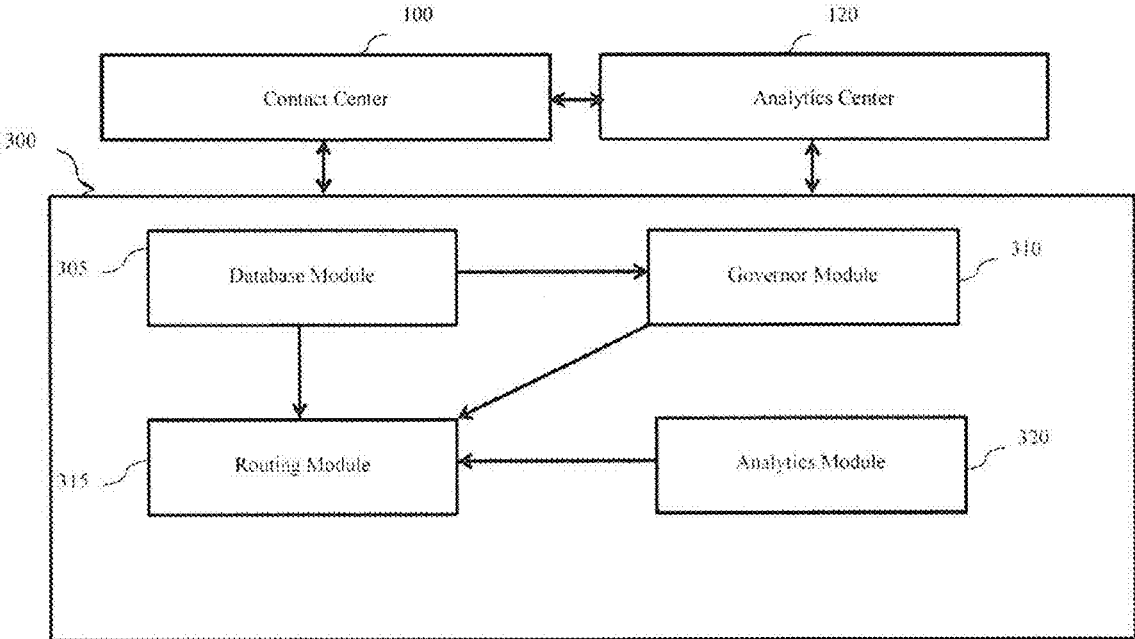

FIG. 3

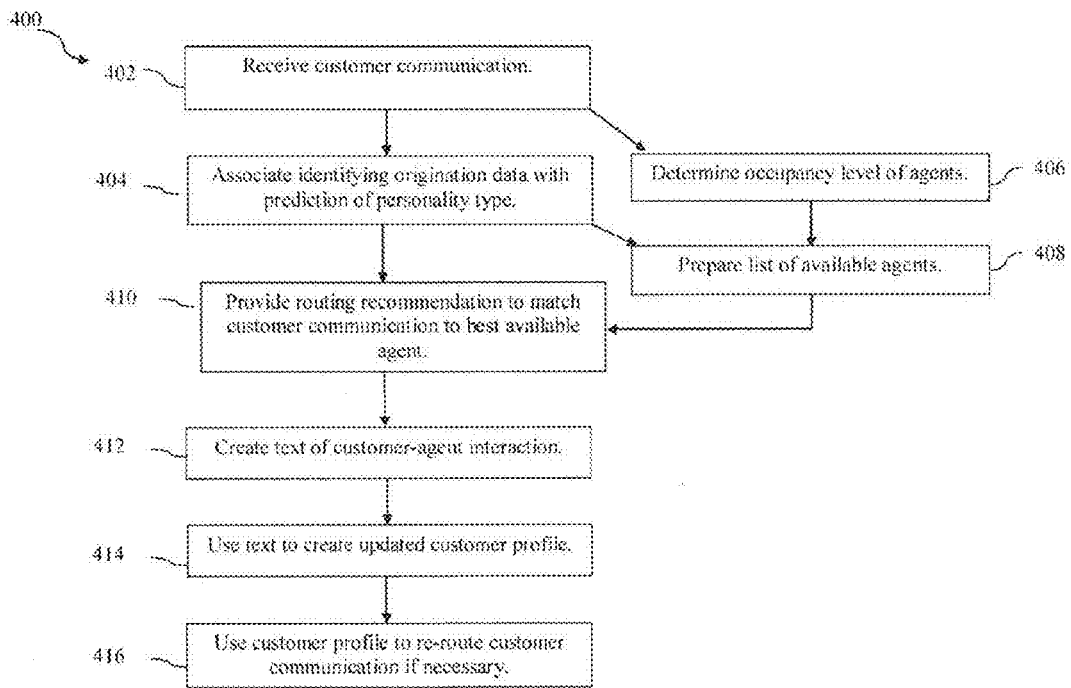

FIG. 4

500 ↘

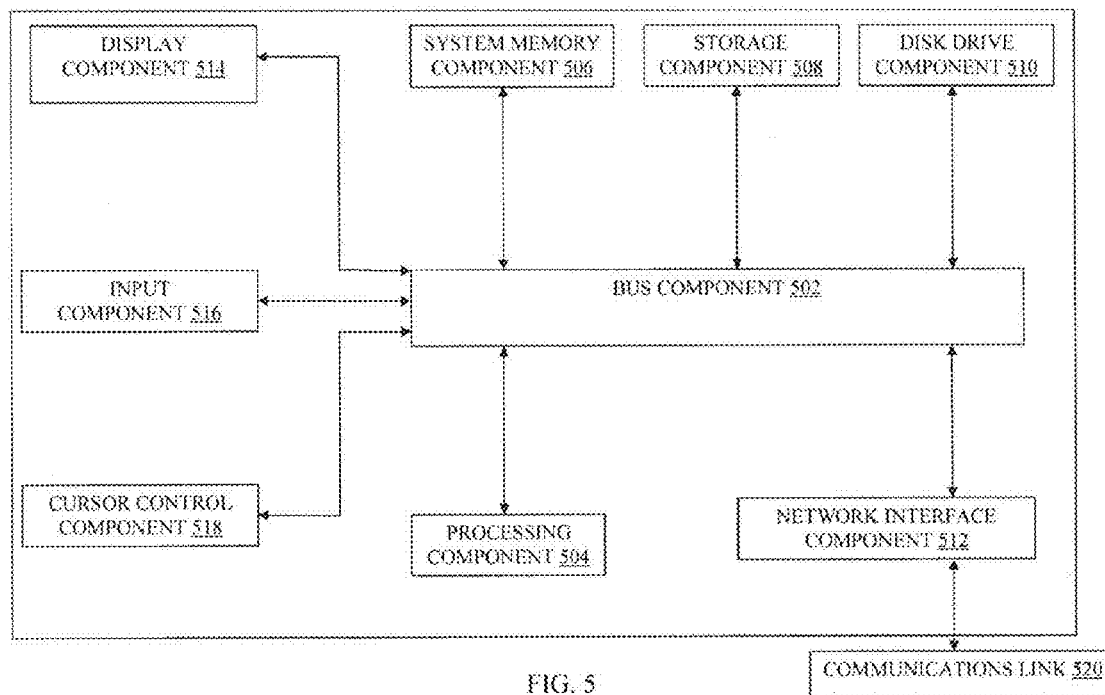

FIG. 5

ADAPTIVE OCCUPANCY REAL-TIME PREDICTIVE ROUTING

CROSS-REFERENCE TO RELATED APPLICATIONS

[0001] This application is a continuation of U.S. application Ser. No. 14/818,082, filed Aug. 4, 2015, now allowed, which is a continuation of U.S. application Ser. No. 14/518,423, filed Oct. 20, 2014, now U.S. Pat. No. 9,137,373, which is a continuation of U.S. application Ser. No. 14/090,949, filed Nov. 26, 2013, now U.S. Pat. No. 8,867,733, which is a continuation of U.S. application Ser. No. 14/049,082, filed Oct. 8, 2013, now abandoned, which is a continuation of Ser. No. 13/828,154, filed Mar. 14, 2013, now U.S. Pat. No. 9,137,372, the entire contents of each of which is hereby incorporated herein its entirety by express reference thereto.

TECHNICAL FIELD

[0002] The present disclosure generally relates to a method, apparatus, and system for routing customer communications, and more particularly to providing routing recommendations based on predicted customer personalities and agent availability.

BACKGROUND OF THE DISCLOSURE

[0003] Call-routing ability and efficiency is important. The time it takes to connect a caller to an agent affects customer satisfaction and hence business image. Mistakes in routing, connecting callers for example to overloaded centers or to agents not prepared to help with the client's difficulty or desire, is troublesome.

[0004] Automatic call distribution systems are known. Often an organization disseminates a single telephone number to its customers and to the public in general as a means of contacting the organization. As calls are directed to the organization from the public switch telephone network, the automatic call distribution system directs the calls to its agents based upon some type of criteria. For example, where all agents are considered equal, the automatic call distributor may distribute the calls based upon which agent has been idle the longest.

[0005] Automatic call distributors are used in communications handling centers, such as telephone call centers, that forward incoming communications, such as telephone calls, for processing by one of several associated call-handling agents. Other communications centers may be used to forward voice-over-internet protocol communications; electronic mail messages; facsimiles or the like, to associated handling agents.

[0006] One concern in designing an automatic call distributor system is ensuring that calls are efficiently routed to an agent, so as to minimize the amount of time that any particular call is placed on hold. One basic technique of minimizing on-hold time is to employ a first-in/first-out call handling technique. The first-in/first-out technique requires that calls be routed to the next available agent in the order in which the calls are received. In many cases, however, the first-in/first-out technique is not appropriate. For example, there may be agents with specialized knowledge or expertise. Utilizing a first-in/first-out technique in such a situation is inappropriate because a caller with a specific question related to a specific area may be routed to an agent not

having specialized knowledge in that area. Improvements in routing techniques and speeds are therefore needed.

SUMMARY

[0007] A customer calls, or otherwise communicates with a contact center. Using identifying origination data from the customer communication, the personality type of the customer is predicted. Agents available to handle the customer communication are also determined and ranked. A routing recommendation is provided based on the predicted personality type and the available agent's proficiency at handling customers with the predicted personality type. In some instances, real-time customer-agent interaction may be analyzed to determine whether the customer communication should be re-routed to another agent.

[0008] The systems, apparatus, and methods disclosed herein may be used to distribute customer tasks or communications to the best available agent on duty at the moment based on personality type and other factors, while excluding all agents who have exceeded their work threshold. The present disclosure describes how to efficiently route customer communications, increase customer satisfaction, and maximize contact center performance.

[0009] In a first aspect, the invention encompasses a system for routing incoming customer tasks that includes a node comprising a processor and a computer readable medium operably coupled thereto, the computer readable medium comprising a plurality of instructions stored in association therewith that are accessible to, and executable by, the processor, where the plurality of instructions includes, instructions, that when executed, receive a customer task, instructions, that when executed, return a list of available agents, wherein the list of available agents excludes agents that exceed a predetermined work threshold, and instructions, that when executed, provide a routing recommendation modified by (including being based on) predicted customer personality type, task type, customer data, agent data, or a combination thereof.

[0010] In a second aspect, the invention encompasses a system for routing incoming customer communications, that includes a database module to associate identifying origination data of a customer with a prediction of a personality type of the customer, a governor module to monitor agent work load and provide a list of available agents, wherein the list of available agents excludes agents that exceed a predetermined work threshold, and a routing module to match customer communications to available agents based on the predicted customer personality type and the available agents' proficiency at handling customers with the predicted personality type.

[0011] In a third aspect, the invention encompasses a method for routing incoming customer communications that includes, receiving a customer communication, predicting a personality type of the customer associated with the customer communication, providing a list of available agents to permit routing of the customer communication, wherein the list of available agents excludes agents that have exceeded a predetermined work threshold, and providing a routing recommendation based on the personality type prediction and the available agent's proficiency at handling customers with the predicted personality type.

[0012] In a fourth aspect, the invention encompasses a computer readable medium comprising a plurality of instructions that includes instructions, that when executed,

receive a customer communication, instructions, that when executed, predict a personality type of the customer associated with the customer communication, instructions, that when executed, determine which agents are available by calculating occupancy for each agent from a list of agents and by excluding all agents from the list who exceed a predetermined work threshold, instructions, that when executed, rank the available agents based on their proficiency at handling customers with the predicted personality profile, and instructions, that when executed, provide a recommendation that directs the customer communication to the best available agent based on the ranking, task type, customer data, agent data, or a combination thereof.

[0013] In a fifth aspect, the present disclosure encompasses a system for routing incoming customer tasks that includes a node comprising a processor and a computer readable medium operably coupled thereto, the computer readable medium comprising a plurality of instructions stored in association therewith that are accessible to, and executable by, the processor, where the plurality of instructions includes: instructions that, when executed, identify origination data for a customer contacting a contact center with a customer task; instructions that, when executed, determine a predicted personality type of the customer based on the identified origination data; and instructions that, when executed, provide a routing recommendation to route the customer to an agent based on the predicted customer personality type and historical customer data.

[0014] In a sixth aspect, the present disclosure encompasses a system for routing incoming customer communications that includes a database module to associate identifying origination data of a customer contacting a contact center, an analytics module to determine a predicted personality type of the customer based on the identified origination data, and a routing module to match a customer communication to an available agent based on the predicted customer personality type and the historical customer data.

[0015] In a seventh aspect, the present disclosure encompasses a method for routing incoming customer communications that includes receiving a customer communication, predicting a personality type of the customer associated with the customer communication, and providing a routing recommendation to route the customer to an agent based on the personality type prediction and historical customer data. In a preferred embodiment, the method further includes providing a list of available agents to permit routing of the customer communication, wherein the list of available agents excludes agents that have exceeded a predetermined work threshold.

[0016] In an eighth aspect, the present disclosure encompasses a non-transitory computer readable medium including a plurality of instructions that include instructions, that when executed, receive a customer communication and identify origination data for the customer contacting the contact center; instructions, that when executed, predict a personality type of the customer associated with the customer communication based on the identified origination data; and instructions, that when executed, provide a routing recommendation that directs the customer communication to the best available agent based on the predicted customer personality type and historical customer data.

[0017] In a ninth aspect, the present disclosure encompasses a system configured to route incoming customer tasks based on agent performance, including a node that includes

a processor and a non-transitory computer readable medium operably coupled thereto, the non-transitory computer readable medium comprising a plurality of instructions stored in association therewith that are accessible to, and executable by, the processor, where the plurality of instructions includes: instructions that, when executed, identify origination data for a customer contacting a contact center with a customer task, instructions that, when executed, monitor real-time agent performance data and modify a predetermined work threshold based on the real-time agent performance data, instructions that, when executed, provide a routing recommendation to a communication distributor to route the customer to an agent based on historical customer data, wherein the agent has not exceeded the predetermined work threshold, and instructions that, when executed, route the communication via the communication distributor to the agent based on the routing recommendation.

[0018] In a tenth aspect, the present disclosure encompasses a system configured to route incoming customer communications that includes a database module to associate identifying origination data of a customer contacting a contact center, a governor module to monitor real-time agent performance data and modify a predetermined work threshold based on the real-time agent performance data, a routing processor to match a customer communication to an available agent based on historical customer data for the customer, wherein the available agent has not exceeded the predetermined work threshold, and a communication distributor that routes the customer communication to the available agent based on the routing match.

[0019] In an eleventh aspect, the present disclosure encompasses a method for routing incoming customer communications, which includes receiving, by one or more processors, a customer communication, monitoring, by the one or more processors, real-time agent performance data and modifying a predetermined work threshold based on the real-time agent performance data, and providing, by the one or more processors, a routing recommendation to a communication distributor to route the customer to an agent based on historical customer data, wherein the agent has not exceeded the predetermined work threshold.

[0020] In a twelfth aspect, the present disclosure encompasses a system configured to simulate a real-time predictive routing system to route incoming customer tasks, including a node that includes a processor and a non-transitory computer readable medium operably coupled thereto, the non-transitory computer readable medium comprising a plurality of instructions stored in association therewith that are accessible to, and executable by, the processor, where the plurality of instructions includes: instructions that, when executed, identify origination data for a customer contacting a contact center with a customer task, instructions that, when executed, monitor agent workload and stop assigning customer tasks to each agent at any time that the agent has exceeded a predetermined work threshold, instructions that, when executed, provide a routing recommendation to route the customer to an agent based on historical customer data, wherein the agent has not exceeded the predetermined work threshold, instructions that, when executed, route the customer to an agent via a communications distributor when the agent has not exceeded the predetermined work threshold, instructions that, when executed, create an actual routing summary of the routing, and instructions that, when executed, compare a recommended routing summary based

on the routing recommendations over a period of time to the actual routing summary over the period of time, and display the comparison to a user on a user display.

[0021] In a thirteenth aspect, the present disclosure encompasses a system configured to route incoming customer communications, including a database module to associate identifying origination data of a customer contacting a contact center, a governor module to monitor real-time agent performance data and modify a predetermined work threshold based on the real-time agent performance data, a routing processor to provide a routing recommendation to route a customer communication to an available agent based on historical customer data for the customer, wherein the available agent has not exceeded the predetermined work threshold, a communication distributor that routes the customer communication to the available agent based on the routing match and creates an actual routing summary of the routes over a period of time, and a simulation module that compares a recommended routing summary based on the routing recommendations over the period of time to the actual routing summary over the period of time, and displays the comparison to a user on a user display.

[0022] In a fourteenth aspect, the present disclosure encompasses a method for routing incoming customer communications, which includes receiving, by one or more processors, a customer communication, monitoring, by the one or more processors, real-time agent performance data and modifying a predetermined work threshold based on the real-time agent performance data, providing, by the one or more processors, a routing recommendation to route the customer to an agent based on historical customer data, wherein the agent has not exceeded the predetermined work threshold, routing the customer to an agent when the agent has not exceeded the predetermined work threshold, creating an actual routing summary of one or more of the routings over a period of time, and comparing a recommended routing summary based on the routing recommendations to the actual routing summary over the period of time, and display the comparison to a user.

BRIEF DESCRIPTION OF THE DRAWINGS

[0023] The present disclosure is best understood from the following detailed description when read with the accompanying figures. It is emphasized that, in accordance with the standard practice in the industry, various features are not drawn to scale. In fact, the dimensions of the various features may be arbitrarily increased or reduced for clarity of discussion.

[0024] FIG. 1 is a simplified block diagram of an embodiment of a contact center according to various aspects of the present disclosure.

[0025] FIG. 2 is a more detailed block diagram of the contact center of FIG. 1 according to aspects of the present disclosure.

[0026] FIG. 3 is simplified block diagram of an embodiment of a contact center, analytics center, and a system for routing customer communications according to various aspects of the present disclosure.

[0027] FIG. 4 is a flowchart illustrating a preferred method of routing customer communications according to aspects of the present disclosure.

[0028] FIG. 5 is a block diagram of a computer system suitable for implementing one or more components in FIG. 3 according to one embodiment of the present disclosure.

DETAILED DESCRIPTION OF THE PREFERRED EMBODIMENTS

[0029] The present disclosure advantageously provides for methods for routing incoming customer communications. These methods typically include receiving a customer communication, predicting a personality type of the customer associated with the customer communication, providing a list of available agents to permit routing of the customer communication, and providing a routing recommendation, which is typically based on the personality type prediction and the available agent's proficiency at handling customers with the predicted personality type. Systems and apparatuses for carrying out these methods are also part of the present disclosure. An exemplary system to route incoming customer tasks includes, for example, a node including a processor and a computer readable medium operably coupled thereto, the computer readable medium comprising a plurality of instructions stored in association therewith that are accessible to, and executable by, the processor, where the plurality of instructions includes instructions, that when executed, receive a customer task, provide a list of available agents (e.g., wherein the list of available agents excludes agents that exceed a predetermined work threshold), and provide a routing recommendation modified by (including being based on) predicted customer personality type, task type, customer data, agent data, or a combination thereof.

[0030] For the purposes of promoting an understanding of the principles of the present disclosure, reference will now be made to the embodiments illustrated in the drawings, and specific language will be used to describe the same. It is nevertheless understood that no limitation to the scope of the disclosure is intended. Any alterations and further modifications to the described devices, systems, and methods, and any further application of the principles of the present disclosure are fully contemplated and included within the present disclosure as would normally occur to one of ordinary skill in the art to which the disclosure relates. In particular, it is fully contemplated that the features, components, and/or steps described with respect to one embodiment may be combined with the features, components, and/or steps described with respect to other embodiments of the present disclosure. For the sake of brevity, however, the numerous iterations of these combinations will not be described separately.

[0031] FIG. 1 is a simplified block diagram of an embodiment of a contact center 100 according to various aspects of the present disclosure. A "contact center" as used herein can include any facility or system server suitable for receiving and recording electronic communications from customers. Such communications can include, for example, telephone calls, facsimile transmissions, e-mails, web interactions, voice over IP ("VoIP") and video. Various specific types of communications contemplated through one or more of these channels include, without limitation, email, SMS data (e.g., text), tweet, instant message, web-form submission, smartphone app, social media data, and web content data (including but not limited to internet survey data, blog data, microblog data, discussion forum data, and chat data), etc. In various aspects, real-time communication, such as voice, video, or both, is preferably included. It is contemplated that these communications may be transmitted by and through any type of telecommunication device and over any medium suitable for carrying data. For example, the communications may be transmitted by or through telephone lines, cable, or

wireless communications. As shown in FIG. 1, the contact center 100 of the present disclosure is adapted to receive and record varying electronic communications and data formats that represent an interaction that may occur between a customer (or caller) and a contact center agent during fulfillment of a customer and agent transaction. In one embodiment, the contact center 100 records all of the customer calls in uncompressed audio formats. In the illustrated embodiment, customers may communicate with agents associated with the contact center 100 via multiple different communication networks such as a public switched telephone network (PSTN) 102 or the Internet 104. For example, a customer may initiate an interaction session through traditional telephones 106, a fax machine 108, a cellular (i.e., mobile) telephone 110, a personal computing device 112 with a modem, or other legacy communication device via the PSTN 102. Further, the contact center 100 may accept internet-based interaction sessions from personal computing devices 112, VoIP telephones 114, and internet-enabled smartphones 116 and personal digital assistants (PDAs).

[0032] Often, in contact center environments such as contact center 100, it is desirable to facilitate routing of customer contacts, particularly based on agent availability and prediction of personality type of the customer occurring in association with a customer interaction, be it a telephone-based interaction, a web-based interaction, or other type of electronic interaction over the PSTN 102 or Internet 104. Traditionally, limited categories of customer data are used to create predictive models. As a result, such models tend not to be as accurate as possible because of limited data inputs and because of the heterogeneous nature of interaction data collected across multiple different communication channels. As one of ordinary skill in the art would recognize, the illustrated example of communication channels associated with a contact center 100 in FIG. 1 is just an example, and the contact center may accept customer interactions, and other analyzed interaction information and/or routing recommendations from an analytics center, through various additional and/or different devices and communication channels whether or not expressly described herein.

[0033] For example, in some embodiments, internet-based interactions and/or telephone-based interactions may be routed through an analytics center 120 before reaching the contact center 100 or may be routed simultaneously to the contact center and the analytics center (or even directly and only to the contact center). In some instances, the analytics center 120 is a third-party analytics company that captures multi-channel interaction data associated with the contact center 100 and applies predictive analytics to the data to generate actionable intelligence for the contact center. For example, the analytics center 120 may provide a routing recommendation according to the present disclosure, a database module to associate identifying origination data of a customer and/or generate a prediction of a personality type of the customer, a governor module to monitor agent work load and provide a list of available agents, a routing module to match customer communications to available agents based on the predicted customer personality type and the available agents' proficiency at handling customers with the predicted personality type, or any combination thereof, as well as providing all of the above functionality. Also, in some embodiments, internet-based interactions may be received and handled by a marketing department associated

with either the contact center 100 or analytics center 120. The analytics center 120 may be controlled by the same entity or a different entity than the contact center 100. Further, the analytics center 120 may be a part of, or independent of, the contact center 100.

[0034] FIG. 2 is a more detailed block diagram of an embodiment of the contact center 100 according to aspects of the present disclosure. As shown in FIG. 2, the contact center 100 is communicatively coupled to the PSTN 102 via a distributed private branch exchange (PBX) switch 130. The PBX switch 130 provides an interface between the PSTN 102 and a local area network (LAN) 132 within the contact center 100. In general, the PBX switch 130 connects trunk and line station interfaces of the PSTN 102 to components communicatively coupled to the LAN 132. The PBX switch 130 may be implemented with hardware or virtually. A hardware-based PBX may be implemented in equipment located local to the user of the PBX system. In contrast, a virtual PBX may be implemented in equipment located at a central telephone service provider that delivers PBX functionality as a service over the PSTN 102. Additionally, in one embodiment, the PBX switch 130 may be controlled by software stored on a telephony server 134 coupled to the PBX switch. In another embodiment, the PBX switch 130 may be integrated within telephony server 134. The telephony server 134 incorporates PBX control software to control the initiation and termination of connections between telephones within the contact center 100 and outside trunk connections to the PSTN 102. In addition, the software may monitor the status of all telephone stations coupled to the LAN 132 and may be capable of responding to telephony events to provide traditional telephone service. In certain embodiments, this may include the control and generation of the conventional signaling tones including without limitation dial tones, busy tones, ring back tones, as well as the connection and termination of media streams between telephones on the LAN 132. Further, the PBX control software may programmatically implement standard PBX functions such as the initiation and termination of telephone calls, either across the network or to outside trunk lines, the ability to put calls on hold, to transfer, park and pick up calls, to conference multiple callers, and to provide caller ID information. Telephony applications such as voice mail and auto attendant may be implemented by application software using the PBX as a network telephony services provider.

[0035] In one embodiment, the telephony server 134 includes a trunk interface that utilizes conventional telephony trunk transmission supervision and signaling protocols required to interface with the outside trunk circuits from the PSTN 102. The trunk lines carry various types of telephony signals such as transmission supervision and signaling, audio, fax, or modem data to provide plain old telephone service (POTS). In addition, the trunk lines may carry other communication formats such T1, ISDN or fiber service to provide telephony or multimedia data images, video, text or audio.

[0036] The telephony server 134 includes hardware and software components to interface with the LAN 132 of the contact center 100. In one embodiment, the LAN 132 may utilize IP telephony, which integrates audio and video stream control with legacy telephony functions and may be supported through the H.323 protocol. H.323 is an International Telecommunication Union (ITU) telecommunications pro-

ocol that defines a standard for providing voice and video services over data networks. H.323 permits users to make point-to-point audio and video phone calls over a local area network. IP telephony systems can be integrated with the public telephone system through an IP/PBX-PSTN gateway, thereby allowing a user to place telephone calls from an enabled computer. For example, a call from an IP telephony client within the contact center **100** to a conventional telephone outside of the contact center would be routed via the LAN**132** to the IP/PBX-PSTN gateway. The IP/PBX-PSTN gateway would then translate the H.323 protocol to conventional telephone protocol and route the call over the PSTN **102** to its destination. Conversely, an incoming call from a customer over the PSTN **102** may be routed to the IP/PBX-PSTN gateway, which translates the conventional telephone protocol to H.323 protocol so that it may be routed to a VoIP-enable phone or computer within the contact center **100**.

[0037] The contact center **100** is further communicatively coupled to the Internet **104** via hardware and software components within the LAN **132**. One of ordinary skill in the art would recognize that the LAN **132** and the connections between the contact center **100** and external networks such as the PSTN **102** and the Internet **104** as illustrated by FIG. **2** have been simplified for the sake of clarity and the contact center may include various additional and/or different software and hardware networking components such as routers, switches, gateways, network bridges, hubs, and legacy telephony equipment.

[0038] In various embodiments, the contact center **100** includes a communication distributor that distributes customer communications or tasks to agents. Generally, the communication distributor is part of a switching system designed to receive customer communications and queue them. In addition, the communication distributor distributes communications to agents or specific groups of agents according to a prearranged scheme.

[0039] As shown in FIG. **2**, the contact center **100** includes a plurality of agent workstations **140** that enable agents employed by the contact center to engage in customer interactions over a plurality of communication channels. In one embodiment, each agent workstation **140** may include at least a telephone and a computer workstation. In other embodiments, each agent workstation **140** may include a computer workstation that provides both computing and telephony functionality. Through the workstations **140**, the agents may engage in telephone conversations with the customer, respond to email inquiries, receive faxes, engage in instant message conversations, respond to website-based inquiries, video chat with a customer, and otherwise participate in various customer interaction sessions across one or more channels. Further, in some embodiments, the agent workstations **140** may be remotely located from the contact center **100**, for example, in another city, state, or country. Alternatively, in some embodiments, an agent may be a software-based application configured to interact in some manner with a customer. An exemplary software-based application as an agent is an online chat program designed to interpret customer inquiries and respond with pre-programmed answers.

[0040] The contact center **100** further includes a contact center control system **142** that is generally configured to provide recording, voice analysis, behavioral analysis, storage, and other processing functionality to the contact center.

In the illustrated embodiment, the contact center control system **142** is an information handling system such as a computer, server, workstation, mainframe computer, or other suitable computing device. In other embodiments, the control system **142** may be a plurality of communicatively coupled computing devices coordinated to provide the above functionality for the contact center **100**. The control system **142** includes a processor **144** that is communicatively coupled to a system memory **146**, a mass storage device **148**, and a communication module **150**. The processor **144** can be any custom made or commercially available processor, a central processing unit (CPU), an auxiliary processor among several processors associated with the control system **142**, a semiconductor-based microprocessor (in the form of a microchip or chip set), a macroprocessor, a collection of communicatively coupled processors, or any device for executing software instructions. The system memory **146** provides the processor **144** with non-transitory, computer-readable storage to facilitate execution of computer instructions by the processor. Examples of system memory may include random access memory (RAM) devices such as dynamic random access memory (DRAM), synchronous DRAM (SDRAM), solid state memory devices, and/or a variety of other memory devices known in the art. Computer programs, instructions, and data, such as known voice prints, may be stored on the mass storage device **148**. Examples of mass storage devices may include hard discs, optical disks, magneto-optical discs, solid-state storage devices, tape drives, CD-ROM drives, and/or a variety of other mass storage devices known in the art. Further, the mass storage device may be implemented across one or more network-based storage systems, such as a storage area network (SAN). The communication module **150** is operable to receive and transmit contact center-related data between local and remote networked systems and communicate information such as customer interaction recordings between the other components coupled to the LAN **132**. Examples of communication modules may include Ethernet cards, 802.11 WiFi devices, cellular data radios, and/or other suitable devices known in the art. The contact center control system **142** may further include any number of additional components, which are omitted for simplicity, such as input and/or output (I/O) devices (or peripherals), buses, dedicated graphics controllers, storage controllers, buffers (caches), and drivers. Further, functionality described in association with the control system **142** may be implemented in software (e.g., computer instructions), hardware (e.g., discrete logic circuits, application specific integrated circuit (ASIC) gates, programmable gate arrays, field programmable gate arrays (FPGAs), etc.), or a combination of hardware and software.

[0041] According to one aspect of the present disclosure, the contact center control system **142** is configured to record, collect, and analyze customer voice data and other structured and unstructured data, and other tools may be used in association therewith to increase efficiency and efficacy of the contact center. As an aspect of this, the control system **142** is operable to record unstructured interactions between customers and agents occurring over different communication channels including without limitation telephone conversations, email exchanges, website postings, social media communications, smartphone application (i.e., app) communications, fax messages, instant message conversations. For example, the control system **142** may include a hardware or software-based recording server to capture the audio of a

standard or VoIP telephone connection established between an agent workstation **140** and an outside customer telephone system. Further, the audio from an unstructured telephone call or video conference session may be transcribed manually or automatically and stored in association with the original audio or video. In one embodiment, multiple communication channels (i.e., multi-channel) may be used according to the invention, either in real-time to collect information, for evaluation, or both. For example, control system **142** can receive, evaluate, and store telephone calls, emails, and fax messages. Thus, multi-channel can refer to multiple channels of interaction data, or analysis using two or more channels, depending on the context herein.

[0042] In addition to unstructured interaction data such as interaction transcriptions, the control system **142** is configured to capture structured data related to customers, agents, and their interactions. For example, in one embodiment, a “cradle-to-grave” recording may be used to record all information related to a particular telephone call from the time the call enters the contact center to the later of: the caller hanging up or the agent completing the transaction. All or a portion of the interactions during the call may be recorded, including interaction with an interactive voice response (IVR) system, time spent on hold, data keyed through the caller’s key pad, conversations with the agent, and screens displayed by the agent at his/her station during the transaction. Additionally, structured data associated with interactions with specific customers may be collected and associated with each customer, including without limitation the number and length of calls placed to the contact center, call origination information, reasons for interactions, outcome of interactions, average hold time, agent actions during interactions with customer, manager escalations during calls, types of social media interactions, number of distress events during interactions, survey results, and other interaction information. In addition to collecting interaction data associated with a customer, the control system **142** is also operable to collect biographical profile information specific to a customer including without limitation customer phone number, account/policy numbers, address, employment status, income, gender, customer “value” data (i.e., customer tenure, money spent as customer, etc.), personality type (as determined by past interactions), and other relevant customer identification and biological information. The control system **142** may also collect agent-specific unstructured and structured data including without limitation agent personality type, gender, language skills, performance data (e.g., customer retention rate, etc.), tenure and salary data, training level, average hold time during interactions, manager escalations, agent workstation utilization, and any other agent data relevant to contact center performance. Additionally, one of ordinary skill in the art would recognize that the types of data collected by the contact center control system **142** that are identified above are simply examples and additional and/or different interaction data, customer data, agent data, and telephony data may be collected and processed by the control system **142**. The control system **142** may store recorded and collected interaction data in a database **152**, including customer data and agent data. In certain embodiments, agent data, such as agent scores for dealing with customers, are updated daily.

[0043] The control system **142** may store recorded and collected interaction data in a database **152**. The database **152** may be any type of reliable storage solution such as a

RAID-based storage server, an array of hard disks, a storage area network of interconnected storage devices, an array of tape drives, or some other scalable storage solution located either within the contact center or remotely located (i.e., in the cloud). Further, in other embodiments, the contact center control system **142** may have access not only to data collected within the contact center **100** but also data made available by external sources such as a third party database **154**. In certain embodiments, the control system **142** may query the third party database for customer data such as credit reports, past transaction data, and other structured and unstructured data.

[0044] Additionally, in some embodiments, an analytics system **160** may also perform some or all of the functionality ascribed to the contact center control system **142** above. For instance, the analytics system **160** may record telephone and internet-based interactions, perform behavioral analyses, predict customer personalities, and perform other contact center-related computing tasks. The analytics system **160** may be integrated into the contact center control system **142** as a hardware or software module and share its computing resources **144**, **146**, **148**, and **150**, or it may be a separate computing system housed, for example, in the analytics center **120** shown in FIG. 1. In the latter case, the analytics system **160** includes its own processor and non-transitory computer-readable storage medium (e.g., system memory, hard drive, etc.) on which to store predictive analytics software and other software instructions.

[0045] The multi-channel interaction data collected in the context of the control center **100** may be subject to a linguistic-based psychological behavioral model to assess the personality of customers and agents associated with the interactions. For example, such a behavioral model may be applied to the transcription of a telephone call, instant message conversation, or email thread, between a customer and agent to gain insight into why a specific outcome resulted from the interaction.

[0046] In one embodiment, interaction data is mined for behavioral signifiers associated with a linguistic-based psychological behavioral model. In particular, the contact center control system **142** searches for and identifies text-based keywords (i.e., behavioral signifiers) relevant to a predetermined psychological behavioral model. In a preferred embodiment, multi-channels are mined for such behavioral signifiers.

[0047] FIG. 3 illustrates an exemplary predictive routing system **300** operatively associated with contact center **100**. In one embodiment, parts or the whole of predictive routing system **300** is integrated into contact center **100**. In another embodiment, parts or the whole of predictive routing system **300** is operated separately from contact center **100**, such as by a processing/analytics company (i.e., in this unshown embodiment, the contact center **100** may be replaced with an analytics center **120** in whole or in part), and predictive routing system **300** provides routing recommendations to contact center **100**. As shown, predictive routing system **300** includes database module **305**, governor module **310**, routing module **315**, and analytics module **320**.

[0048] As shown, database module **305** receives customer communication data from contact center **100** and associates identifying origination data of the customer with a prediction of what personality type the customer is likely to be. Identifying origination data typically includes a contact number or network address, or any combination thereof. The

contact number may include at least one of a telephone number, a text message number, short message service (SMS) number, multimedia message service (MMS) number, or a combination thereof. The network address can include at least one of an email address, electronic messaging address, voice over IP address, IP address, social media identifier (e.g., Facebook identifier, Twitter identifier, chat identifier), or a combination thereof. These identifiers are associated with personality types based on the linguistic model.

[0049] It is well known that certain psychological behavioral models have been developed as tools to evaluate and understand how and/or why one person or a group of people interacts with another person or group of people. The Process Communication Model™ (“PCM”) developed by Dr. Taibi Kahler is a preferred example of one such behavioral model. Specifically, PCM presupposes that all people fall primarily into one of six basic personality types: Reactor, Workaholic, Persister, Dreamer, Rebel and Promoter. Although each person is one of these six types, all people have parts of all six types within them arranged like a “six-tier configuration.” Each of the six types learns differently, is motivated differently, communicates differently, and has a different sequence of negative behaviors in which they engage when they are in distress. Importantly each PCM personality type responds positively or negatively to communications that include tones or messages commonly associated with another of the PCM personality types. Thus, an understanding of a communicant’s PCM personality type offers guidance as to an appropriate responsive tone or message. Exemplary methods of applying a psychological behavioral model to contact center communications are described in U.S. Pat. Nos. 7,995,717 and 8,094,803, and U.S. patent application Ser. No. 13/782,522, filed Mar. 1, 2013, entitled “Customer-Based Interaction Outcome Prediction Methods and System,” the entire contents of each of which is incorporated herein in its entirety by express reference thereto.

[0050] In one embodiment, the prediction of customer personality type is based on past calls or communications to that contact center and other organizations. For instance, the prediction can be based on previous transactions between the customer and contact center, the answers to menu choices, past purchase history, past calling history, past survey responses, etc. This prediction can be created and/or stored in the database module 305 from past interaction with the customer.

[0051] The database module 305 contains the aggregated summary of scores across the six personality types in a linguistic model and predicts which personality type the customer is most likely to be. The aggregated summary of scores weighs certain communications differently to predict the personality type of the customer in one embodiment. For example, if there are multiple calls from a single telephone number, more recent calls are given more weight than older calls. Also, the time of day can be taken into account to predict personality type of the customer if more than one personality type is associated with a single telephone number. For example, if the telephone number is associated with an emotions based customer during the day, and a thoughts based customer at night, the database module 305 can return a customer personality type prediction based on that pattern.

[0052] In various embodiments, one or more copies of the database module 305 may be housed close to or in the

contact center 100 to decrease the time needed to transfer the information from the database module 305 to the routing module 315 (when the routing module 315 is integrated in contact center 100), and to help minimize router decision time. The original may be stored at an analytics center or datafarm site. Because the database module 305 is typically very large, the data should be carefully structured so that the database module 305 can return results within a very short period of time, as the data returned from the database module 305 is used to route the customer communication or task to an agent. When the original or a copy are stored near the contact center 100, the database module 305 may be mirrored at the contact center 100 to improve result times, and any copies may be updated periodically (e.g., weekly) with new customer data. In some embodiments, the database module 305 is updated and copied out every night.

[0053] The governor module 310 monitors agent workload and stops assigning customer tasks to agents once agents have exceeded a predetermined work threshold. This can be based on, e.g., legal requirements, such as a maximum permitted workweek, agent preference, determination of an optimum maximum threshold beyond which performance degrades, or the like, or any combination thereof. In some embodiments, governor module 310 is in communication with an agent queue of contact center 100. The governor module 310 calculates the amount of utilization time for each agent, so that once agents have reached a predetermined work threshold they will be taken out of the queue for assignment by the routing module 315 until their occupancy level drops below the predetermined work threshold. In some embodiments, the utilization calculations are done in real-time. “Utilization time,” as used herein, means the time agents spend communicating with a customer and time spent doing additional customer related tasks after the communication.

[0054] Occupancy level is calculated using the following equation:

$$\text{Utilization time/logged in time.}$$

[0055] When the governor module 310 is queried by the contact center to return a list of available agents for an incoming customer task, agents that are above the predetermined work threshold are excluded from the group considered for the task, and the remaining agents are ranked. In certain embodiments, the agents are ranked based on their proficiency for handling customers with the predicted personality type and/or the type of task.

[0056] In one embodiment, when all agents are working above the predetermined work threshold, a routing recommendation may not be provided. Instead, a supervisor or other authorized user may raise the predetermined work threshold to a higher second predetermined work threshold. In certain embodiments, the authorized user has the ability to adjust the governor module 310 at any time. A routing recommendation may then be provided based on the higher second predetermined work threshold.

[0057] In another embodiment, the governor module 310 recognizes that all agents are above the occupancy level and continues to make routing recommendations. The governor module 310 can automatically raise the predetermined threshold to a higher second predetermined work threshold that is triggered when all agents are above the initial predetermined work threshold.

[0058] The governor module **310** dynamically determines occupancy rate in real time, or near-real time. For example, near-real time may be necessitated by communication delays between inputs from a contact center and receipt and processing by an analytics center, causing a delay, e.g., of about 1 to 10 seconds. Once an agent's occupancy rate falls below the adapted threshold, that agent will be returned to the queue. For example, if the predetermined work threshold is 75%, and an agent's occupancy level is 85%, that agent will be taken out of the queue. Once the agent's occupancy level is below 75%, the agent is placed back in the queue by the governor module.

[0059] In various embodiments, the governor module **315** is integrated with a contact center's existing environment, communication distributor hardware, and software. The governor module **315** does not handle call control or reserve agents, but informs the communication distributor of a contact center which agents should be taken out of the queue. The governor module **315** tracks agent utilization for all agents in the queue and measures agent availability and agent occupancy.

[0060] In certain embodiments, the governor module **315** allows the occupancy level to be adjusted to a customized level that is called the "adapted threshold." The industry standard is presently about an 80-85% adapted threshold for full utilization. The occupancy level customization for the adapted threshold also allows occupancy to be attributed in different ways for different types of incoming customer tasks. For example, agents receiving complaint calls can have a different threshold than sales call agents. In addition, the threshold can be set differently based on agent skills and communication type, so that top quartile sales agents will be worked to 85% occupancy and the rest of the agents to 80% occupancy or some other lower occupancy. The threshold may also be set based on personality type, so that the governor module **315** may use a different threshold if there is an 80% utilized agent, but is a top quartile thoughts-based agent.

[0061] The routing module **315** matches incoming customer tasks and their related customer personality type predictions with agents made available by the governor module **310**. The match-ups can be made based on the customer personality type prediction and information from an agent database that includes the agent's proficiency scores for handling customers with that personality type. The match-ups can also be made based on a number of other factors, such as the type of task, the agent's training, and the agent's workload.

[0062] In one embodiment, routing module **315** is in communication with the communication distributor of the contact center. Routing module **315** provides a routing recommendation to the communication distributor, which can then distribute the customer task to the best available agent.

[0063] In certain embodiments, the routing module **315** provides a route summary including the number of routes produced, the number of times the recommended routes were adopted, and an estimate of the amount of money saved. In some embodiments, the routing module **315** provides real-time hourly and daily reporting. The reporting function of the routing module **315** allows the contact center to see that the routing module **315** is actually providing routing recommendations for routing customer contacts,

rather than having a default system (e.g., communication distributor of the contact center) route the customer contacts.

[0064] In other embodiments, the routing module **315** may include a simulator that shows simulated routing on top of the default system, so that the contact center can compare the default system to the routing module **315**.

[0065] Analytics module **330** analyzes customer-agent interaction during the customer task. If the task involves speaking or other forms of voice-based communication, snippets of that communication are sent to an analytics server to analyze the task interaction as it is happening. This gives the agent more information about the customer and provides a more accurate secondary routing personality prediction so that, if the task requires additional routing during the customer contact, the routing module **315** or an agent can use that information to provide routing recommendations regarding the best available agent. Information that may be determined by the analytics module **320** includes, without limitation, personality type of the customer, engagement, state of mind, distress, life events, and purpose of contact/task.

[0066] An exemplary method **400** of routing customer tasks or communications will now be described with respect to FIG. 4. At step **402**, a customer communication or task is received at contact center **100**. Again in FIG. 4, the contact center **100** in one embodiment may be replaced by, or be associated with, an analytics center **120** as seen in FIG. 3. The communication type may include voice calls, voice over IP, facsimiles, emails, web page submissions, internet chat sessions, wireless messages (e.g., text messages such as SMS (short messaging system) messages or paper messages), short message service (SMS), multimedia message service (MMS), or social media (e.g., Facebook identifier, Twitter identifier, etc.), IVR telephone sessions, voicemail messages (including emailed voice attachments), or any combination thereof.

[0067] The database module **305** then receives a request from the contact center **100** including identifying origination data of the customer. At step **404**, the database module **305** associates the identifying origination data with a prediction of the personality type of the customer. The database module **305** accesses and retrieves customer characteristics and scores and provides the governor module **310** and routing module **315** with this information. In one embodiment, it provides a prediction of the customer personality type.

[0068] At step **406**, the governor module **310** determines the occupancy level of agents, e.g., by obtaining agent data from the contact center **100**. The governor module **310** dynamically monitors occupancy level of the agents to determine availability and addresses the real-time performance metrics of the agent. This real-time (or near-real time) dynamic data is typically used to select a destination for the customer communication. Unlike conventional sequential routing schemes, preference in this embodiment is based on both customer information and agent availability.

[0069] At step **408**, the governor module **310** prepares a list of available agents and ranks the available agents based on certain selected criteria, e.g., agent's proficiency in handling customers with the predicted personality type. Available agents are those agents who have not exceeded a predetermined work threshold. This list of available agents is provided to routing module **315**.

[0070] At step **410**, the routing module **315** provides a routing recommendation that matches the customer commu-

nication to the best available agent. Based on the customer personality prediction type, available agents, agent data, task type (which may be from IVR), customer data, customer contact events, environmental events, etc., the routing module 315 provides the communication distributor of the contact center with the available agent best suited to take the customer communication. Agent data includes, but is not limited to agent performance metrics, tenure, agent personality type analytics scores, and other data about the agent. Customer data includes, but is not limited to, customer ID, account history with the contact center, customer contact frequency or history (including prior instances of distress), and other relevant available customer attributes.

[0071] The routing module 315 may make routing decisions based on comparing various customer data and agent data, which may include, e.g., performance based data, demographic data, psychographic data, and other business-relevant data. The routing module 315 assesses the skills of available agents to establish which agents possess the skills that are most needed for the customer communication.

[0072] After the customer task is routed to an initial agent, at step 412, the contact center 100 may create a text of the initial customer-agent interaction in step 412. The contact center 100 sends a text of the customer interaction to the analytics server of analytic module 320, which will then return information regarding customer personality type to build an updated profile of the customer in near real-time at step 414. Alternatively, in an unshown embodiment, the analytics center 120 receives the initial customer-agent interaction, or a text thereof, for processing by the analytics server of analytic module 230. If the customer contact is a telephone call, the audio of the call can be recorded, transmitted and analyzed. If the customer communication is already text based (on-line chat, email, social media contact, text message, etc.), then the text can be sent directly to the analytics module 320 and processed similarly. For example, the analytics server can analyze the extracted text to identify one or more customer issues. These issues may require attention and be routed appropriately, or may be used to create a new prediction for that customer that is stored in the national database or other appropriate database.

[0073] The analytics server of the analytics module 320 may use the following inputs to create the updated customer profile: text, linguistic algorithms (distress, personality styles, life events, engagements), previously stored results, and the results of additional analytics added to the profile, and any combination thereof. The analytics server creates a profile of the customer progressively based on these small segments during the customer interaction. The updated customer profile is sent to the routing module 315 in step 416, so that if the customer needs to be transferred to a second agent, the routing module 315 can use the newly updated profile of the customer to determine which available agents are the best agents for the transfer.

[0074] The real-time (or near real-time) routing function of method 400 can operate on both the initial agent assignment and possible secondary transfer agent assignment. A communication distributor of a contact center assigns each incoming communication to the agent who is the best match for the communications based on inputs from database module 305, the governor module 310, the routing module 315, and a database containing agent personality information and customer personality information. In some embodiments, inputs from the analytics module 320 are also used.

[0075] Referring now to FIG. 5, illustrated is a block diagram of a system 500 suitable for implementing embodiments of the present disclosure, including database module 305, governor module 310, routing module 315, and analytics module 320 depicted in FIG. 3. System 500, such as part a computer and/or a network server, includes a bus 502 or other communication mechanism for communicating information, which interconnects subsystems and components, including one or more of a processing component 504 (e.g., processor, micro-controller, digital signal processor (DSP), etc.), a system memory component 506 (e.g., RAM), a static storage component 508 (e.g., ROM), a network interface component 512, a display component 514 (or alternatively, an interface to an external display), an input component 516 (e.g., keypad or keyboard), and a cursor control component 518 (e.g., a mouse pad).

[0076] In accordance with embodiments of the present disclosure, system 500 performs specific operations by processor 504 executing one or more sequences of one or more instructions contained in system memory component 506. Such instructions may be read into system memory component 506 from another computer readable medium, such as static storage component 508. These may include instructions to associate identifying origination data with a predicted personality type, provide a list of available agents based on occupancy level and a predetermined work threshold, provide a routing recommendation of the best available agent, actually route the customer communication to the best available agent, etc. In other embodiments, hard-wired circuitry may be used in place of or in combination with software instructions for implementation of one or more embodiments of the disclosure.

[0077] Logic may be encoded in a computer readable medium, which may refer to any medium that participates in providing instructions to processor 504 for execution. Such a medium may take many forms, including but not limited to, non-volatile media, volatile media, and transmission media. In various implementations, volatile media includes dynamic memory, such as system memory component 506, and transmission media includes coaxial cables, copper wire, and fiber optics, including wires that comprise bus 502. Memory may be used to store visual representations of the different options for searching or auto-synchronizing. In one example, transmission media may take the form of acoustic or light waves, such as those generated during radio wave and infrared data communications. Some common forms of computer readable media include, for example, RAM, PROM, EPROM, FLASH-EPROM, any other memory chip or cartridge, carrier wave, or any other medium from which a computer is adapted to read.

[0078] In various embodiments of the disclosure, execution of instruction sequences to practice the disclosure may be performed by system 500. In various other embodiments, a plurality of systems 500 coupled by communication link 520 (e.g., networks 102 or 104 of FIG. 1, LAN, WLAN, PTSN, or various other wired or wireless networks) may perform instruction sequences to practice the disclosure in coordination with one another. Computer system 500 may transmit and receive messages, data, information and instructions, including one or more programs (i.e., application code) through communication link 520 and communication interface 512. Received program code may be

executed by processor 504 as received and/or stored in disk drive component 510 or some other non-volatile storage component for execution.

[0079] In view of the present disclosure, it will be appreciated that various methods and systems have been described according to one or more embodiments for routing incoming customer communications and tasks.

[0080] Where applicable, various embodiments provided by the present disclosure may be implemented using hardware, software, or combinations of hardware and software. Also where applicable, the various hardware components and/or software components set forth herein may be combined into composite components comprising software, hardware, and/or both without departing from the spirit of the present disclosure. Where applicable, the various hardware components and/or software components set forth herein may be separated into sub-components comprising software, hardware, or both without departing from the spirit of the present disclosure. In addition, where applicable, it is contemplated that software components may be implemented as hardware components, and vice-versa.

[0081] Software in accordance with the present disclosure, such as program code and/or data, may be stored on one or more computer readable mediums. It is also contemplated that software identified herein may be implemented using one or more general purpose or specific purpose computers and/or computer systems, networked and/or otherwise. Where applicable, the ordering of various steps described herein may be changed, combined into composite steps, and/or separated into sub-steps to provide features described herein.

[0082] The foregoing outlines features of several embodiments so that a person of ordinary skill in the art may better understand the aspects of the present disclosure. Such features may be replaced by any one of numerous equivalent alternatives, only some of which are disclosed herein. One of ordinary skill in the art should appreciate that they may readily use the present disclosure as a basis for designing or modifying other processes and structures for carrying out the same purposes and/or achieving the same advantages of the embodiments introduced herein. One of ordinary skill in the art should also realize that such equivalent constructions do not depart from the spirit and scope of the present disclosure, and that they may make various changes, substitutions and alterations herein without departing from the spirit and scope of the present disclosure.

[0083] The Abstract is provided to comply to allow a quick determination of the nature of the technical disclosure. It is submitted with the understanding that it will not be used to interpret or limit the scope or meaning of the claims.

What is claimed is:

1. A system configured to route incoming customer tasks based on agent performance, comprising:

a node comprising a processor and a non-transitory computer readable medium operably coupled thereto, the non-transitory computer readable medium comprising a plurality of instructions stored in association therewith that are accessible to, and executable by, the processor, where the plurality of instructions comprises:

instructions that, when executed, identify origination data for a customer contacting a contact center with a customer task;

instructions that, when executed, monitor real-time agent performance data and modify a predetermined work threshold based on the real-time agent performance data;

instructions that, when executed, provide a routing recommendation to a communication distributor to route the customer to an agent based on historical customer data, wherein the agent has not exceeded the predetermined work threshold; and

instructions that, when executed, route the communication via the communication distributor to the agent based on the routing recommendation.

2. The system of claim 1, wherein the predetermined work threshold is lowered if the real-time agent performance data is lower than previously determined real-time agent performance data.

3. The system of claim 1, wherein the real-time agent performance data includes one or more of the agent's proficiency score, the agent's workload, or a combination thereof.

4. The system of claim 2, wherein the agent's proficiency score is for a type of task, a customer having a particular personality type, or both.

5. The system of claim 1, wherein the predetermined work threshold is set higher for a top percentage of agents and at one or more lower values for the remaining agents.

6. The system of claim 1, the historical customer data comprises past interaction data with the customer, one or more previous transactions between the customer and a contact center, past purchase history, past calling history, past survey responses, or a combination thereof.

7. The system of claim 1, which further comprises instructions that, when executed, analyze one or more received, real-time interactions between the customer and an initial available agent.

8. The system of claim 7, which further comprises instructions that, when executed, create or update a customer profile based on the analysis.

9. A system configured to route incoming customer communications, comprising:

a database module to associate identifying origination data of a customer contacting a contact center;

a governor module to monitor real-time agent performance data and modify a predetermined work threshold based on the real-time agent performance data;

a routing processor to match a customer communication to an available agent based on historical customer data for the customer, wherein the available agent has not exceeded the predetermined work threshold; and

a communication distributor that routes the customer communication to the available agent based on the routing match.

10. An analytics center comprising the system of claim 9.

11. A method for routing incoming customer communications, which comprises:

receiving, by one or more processors, a customer communication;

monitoring, by the one or more processors, real-time agent performance data and modifying a predetermined work threshold based on the real-time agent performance data; and

providing, by the one or more processors, a routing recommendation to a communication distributor to route the customer to an agent based on historical

customer data, wherein the agent has not exceeded the predetermined work threshold.

12. The method of claim **11**, which comprises lowering the predetermined work threshold if the real-time agent performance data is lower than previously determined real-time agent performance data.

13. The method of claim **11**, wherein the real-time agent performance data is selected to include one or more of the agent's proficiency score, the agent's workload, or a combination thereof.

14. The method of claim **12**, wherein the agent's proficiency score is selected to comprise a type of task, a customer having a particular personality type, or both.

15. The method of claim **11**, wherein the predetermined work threshold is set higher for a top percentage of agents and at one or more lower values for the remaining agents.

16. A system configured to simulate a real-time predictive routing system to route incoming customer tasks, which comprises:

a node comprising a processor and a non-transitory computer readable medium operably coupled thereto, the non-transitory computer readable medium comprising a plurality of instructions stored in association therewith that are accessible to, and executable by, the processor, where the plurality of instructions comprises:

instructions that, when executed, identify origination data for a customer contacting a contact center with a customer task;

instructions that, when executed, monitor agent workload and stop assigning customer tasks to each agent at any time that the agent has exceeded a predetermined work threshold;

instructions that, when executed, provide a routing recommendation to route the customer to an agent based on historical customer data, wherein the agent has not exceeded the predetermined work threshold;

instructions that, when executed, route the customer to an agent via a communications distributor when the agent has not exceeded the predetermined work threshold;

instructions that, when executed, create an actual routing summary of the routing; and

instructions that, when executed, compare a recommended routing summary based on the routing recommendations over a period of time to the actual routing summary over the period of time, and display the comparison to a user on a user display.

17. The system of claim **16**, wherein the routing recommendations are based on a different predetermined work threshold for each agent than the routing.

18. The system of claim **17**, wherein the different predetermined work threshold is based on an agent's real-time performance data.

19. The system of claim **16**, wherein the display shows one or more routing recommendations over the routing.

20. The system of claim **16**, wherein the display shows the recommended routing summary over the actual routing summary, each for the period of time, for one or more agents.

21. A system configured to route incoming customer communications, comprising:

a database module to associate identifying origination data of a customer contacting a contact center;

a governor module to monitor real-time agent performance data and modify a predetermined work threshold based on the real-time agent performance data;

a routing processor to provide a routing recommendation to route a customer communication to an available agent based on historical customer data for the customer, wherein the available agent has not exceeded the predetermined work threshold;

a communication distributor that routes the customer communication to the available agent based on the routing match and creates an actual routing summary of the routes over a period of time; and

a simulation module that compares a recommended routing summary based on the routing recommendations over the period of time to the actual routing summary over the period of time, and displays the comparison to a user on a user display.

22. An analytics center comprising the system of claim **21**.

23. A method for routing incoming customer communications, which comprises:

receiving, by one or more processors, a customer communication;

monitoring, by the one or more processors, real-time agent performance data and modifying a predetermined work threshold based on the real-time agent performance data;

providing, by the one or more processors, a routing recommendation to route the customer to an agent based on historical customer data, wherein the agent has not exceeded the predetermined work threshold;

routing the customer to an agent when the agent has not exceeded the predetermined work threshold;

creating an actual routing summary of one or more of the routings over a period of time; and

comparing a recommended routing summary based on the routing recommendations to the actual routing summary over the period of time, and display the comparison to a user.

24. The method of claim **23**, wherein the routing recommendations are selected based on a different predetermined work threshold for each agent than the routing.

25. The method of claim **24**, wherein the different predetermined work threshold is selected based on an agent's real-time performance data.

26. The method of claim **23**, wherein the display shows one or more routing recommendations over the routing for the period of time.

27. The method of claim **23**, wherein the display shows the recommended routing summary over the actual routing summary, each for the period of time, for one or more agents.

* * * * *