



(19) **United States**

(12) **Patent Application Publication**
Bragstad et al.

(10) **Pub. No.: US 2015/0334155 A1**

(43) **Pub. Date: Nov. 19, 2015**

(54) **DEPLOYING A PORTION OF A STREAMING APPLICATION TO ONE OR MORE VIRTUAL MACHINES ACCORDING TO COST**

Publication Classification

(71) Applicant: **International Business Machines Corporation**, Armonk, NY (US)

(51) **Int. Cl.**
H04L 29/06 (2006.01)
H04L 29/08 (2006.01)
H04L 12/927 (2006.01)

(72) Inventors: **Lance Bragstad**, Pine Island, MN (US);
Michael J. Branson, Rochester, MN (US);
Bin Cao, Rochester, MN (US);
James E. Carey, Rochester, MN (US);
Mathew R. Odden, Rochester, MN (US)

(52) **U.S. Cl.**
CPC *H04L 65/80* (2013.01); *H04L 47/805* (2013.01); *H04L 67/10* (2013.01)

(21) Appl. No.: **14/304,893**

(22) Filed: **Jun. 14, 2014**

Related U.S. Application Data

(63) Continuation of application No. 14/276,156, filed on May 13, 2014.

(57) **ABSTRACT**

A streams manager monitors cost of one or more VMs hosting a streaming application, determines when cost can be reduced, and requests a cloud manager provision one or more VMs that have a lower cost. In response, the cloud manager provisions the VM(s) that have the lower cost. The streams manager then deploys a portion of the streaming application to the VM(s), thereby reducing the cost of running the streaming application.

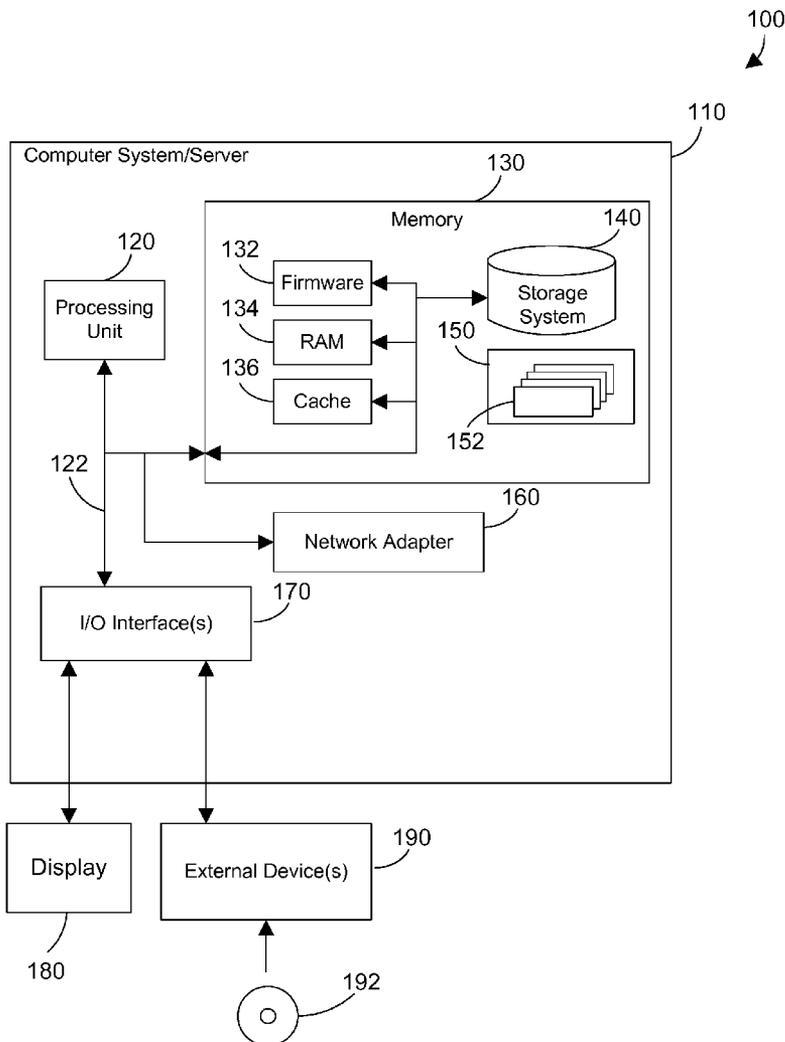

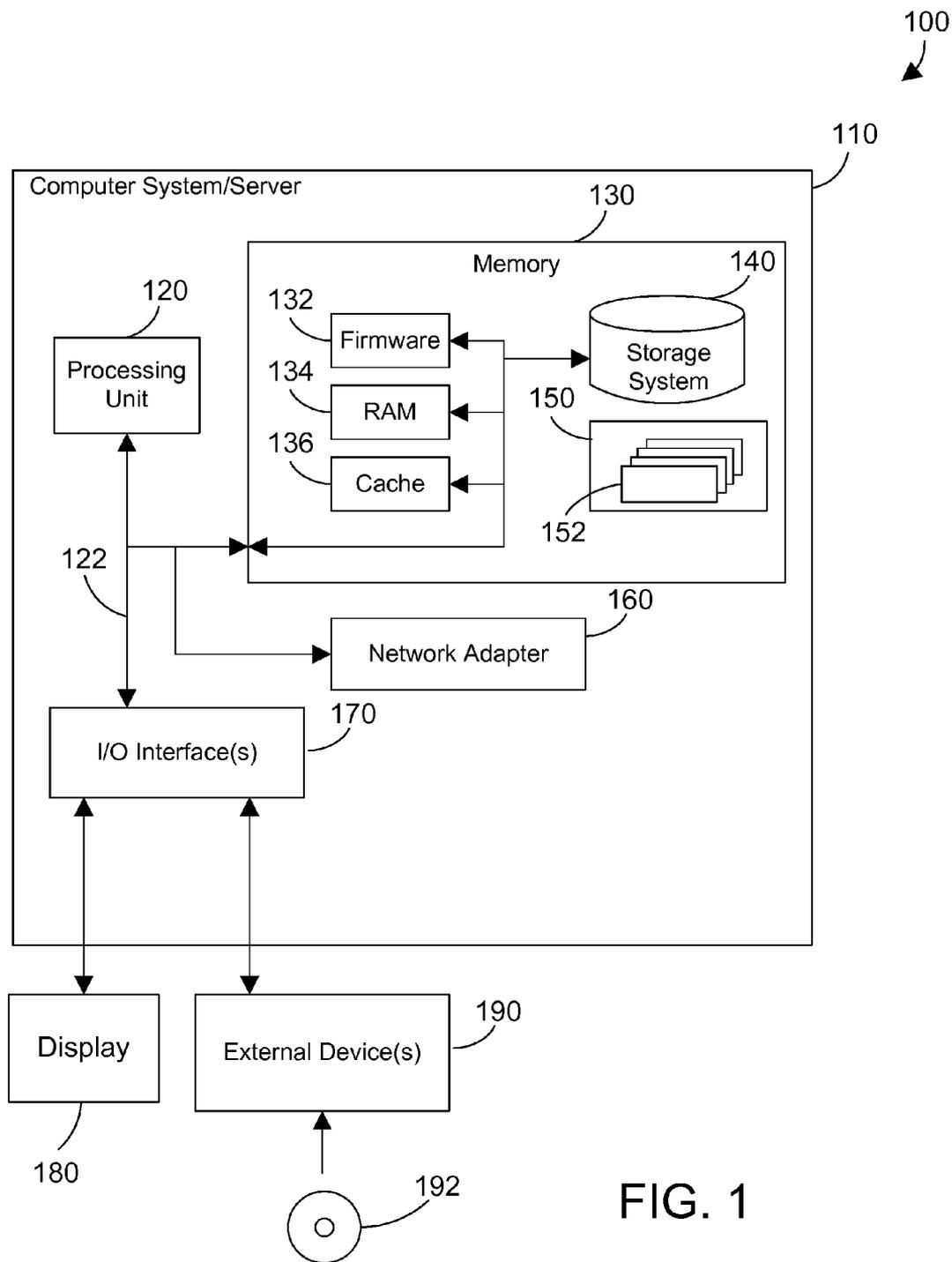

FIG. 1

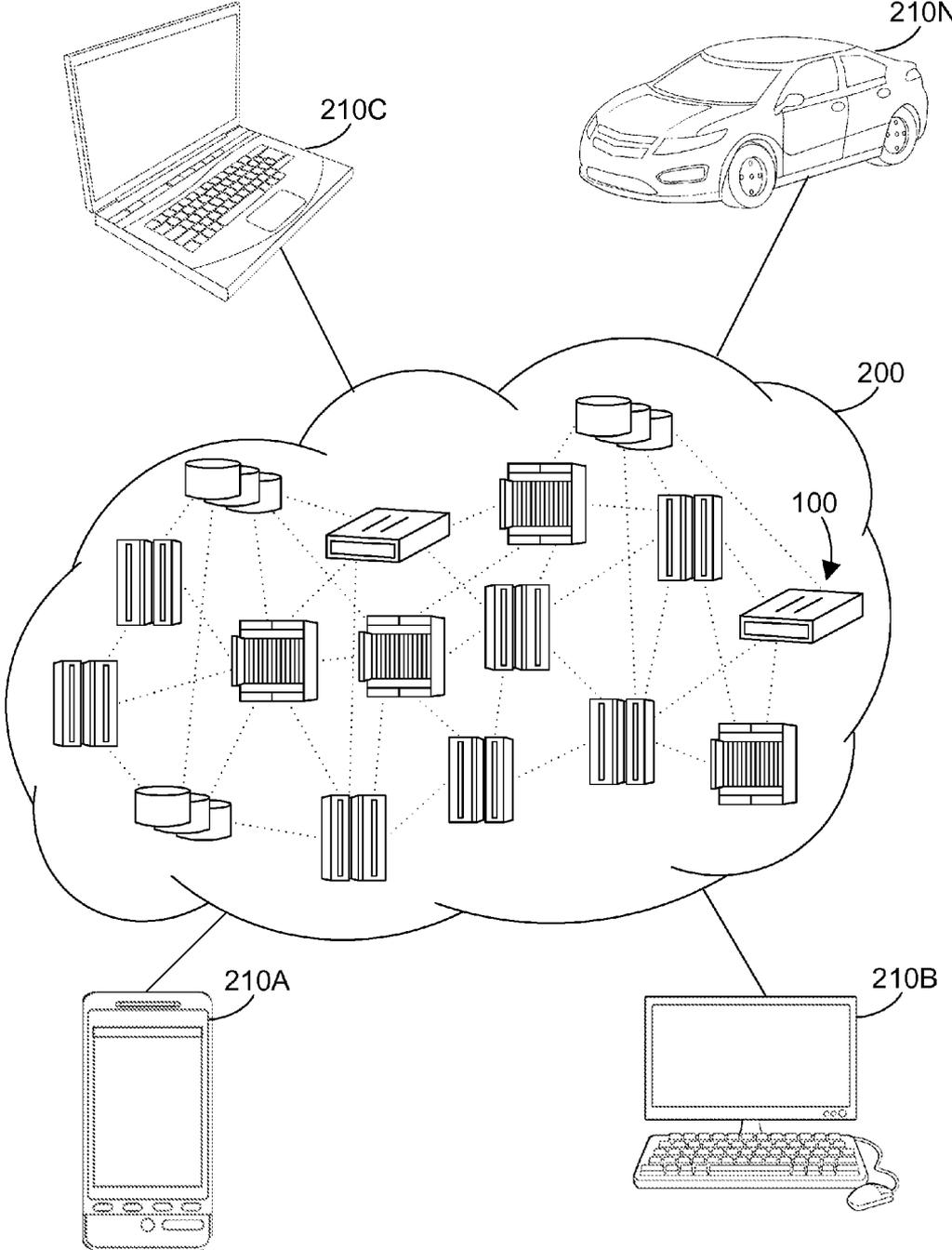

FIG. 2

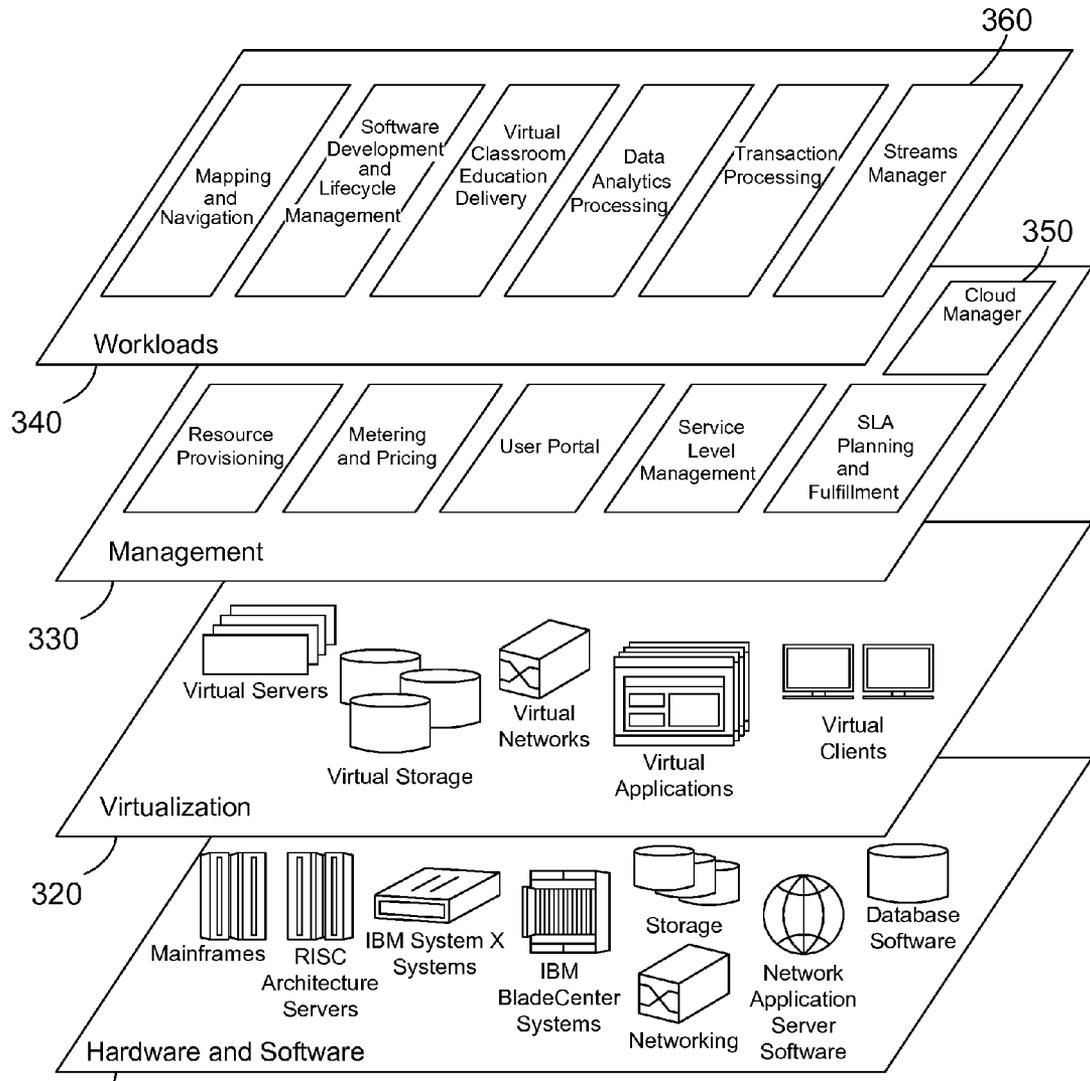

FIG. 3

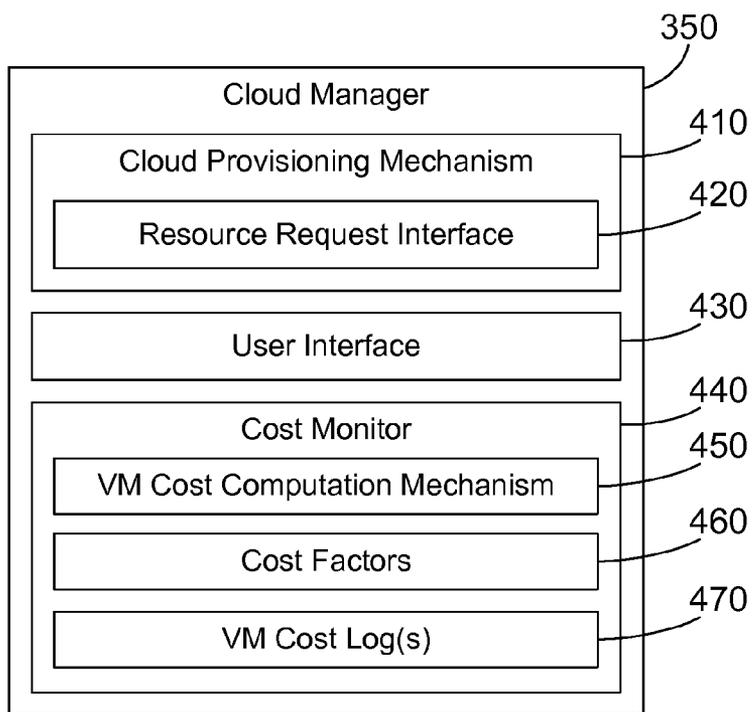

FIG. 4

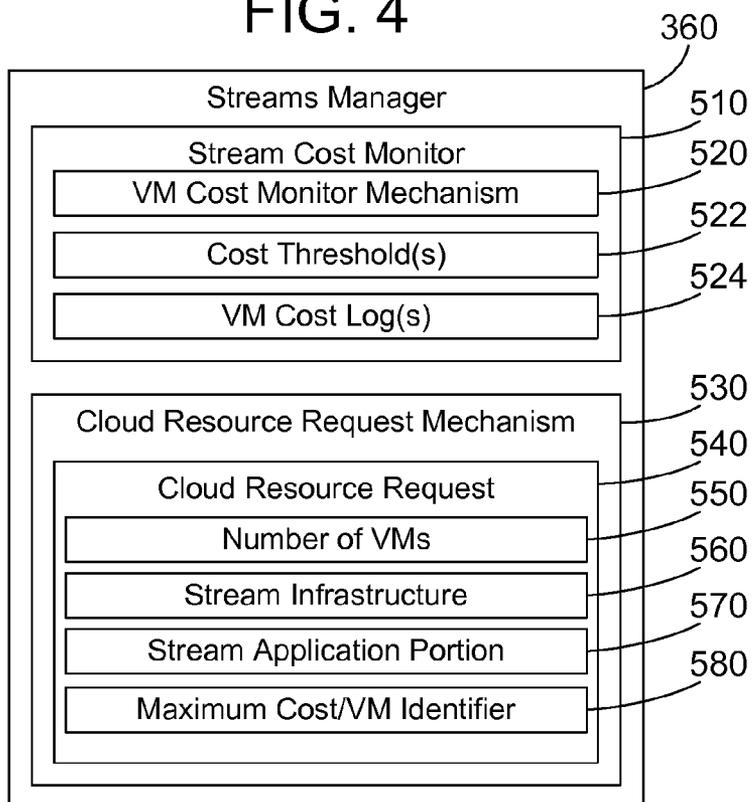

FIG. 5

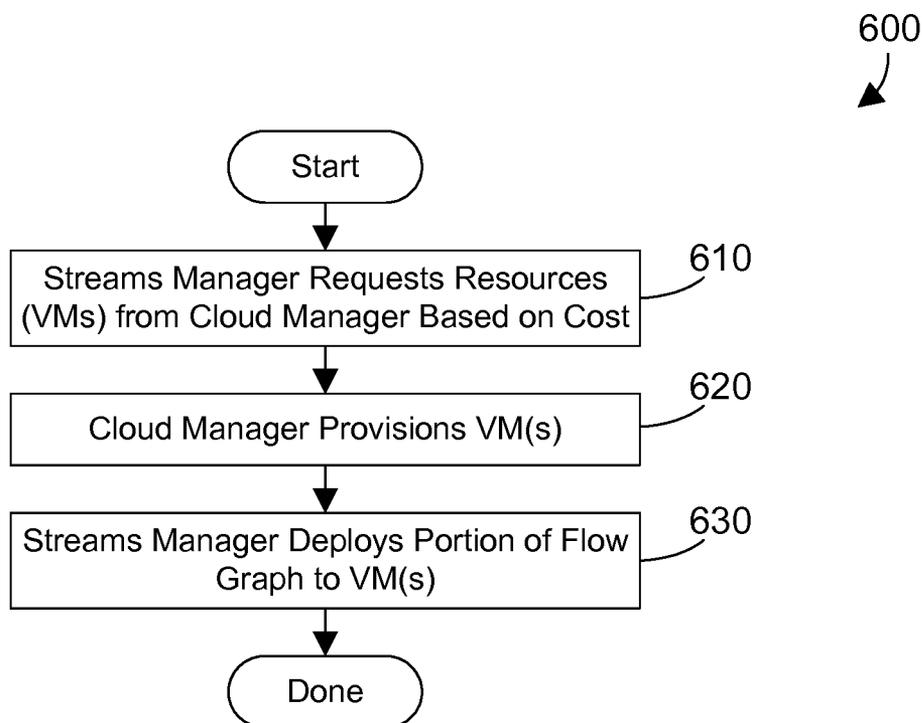

FIG. 6

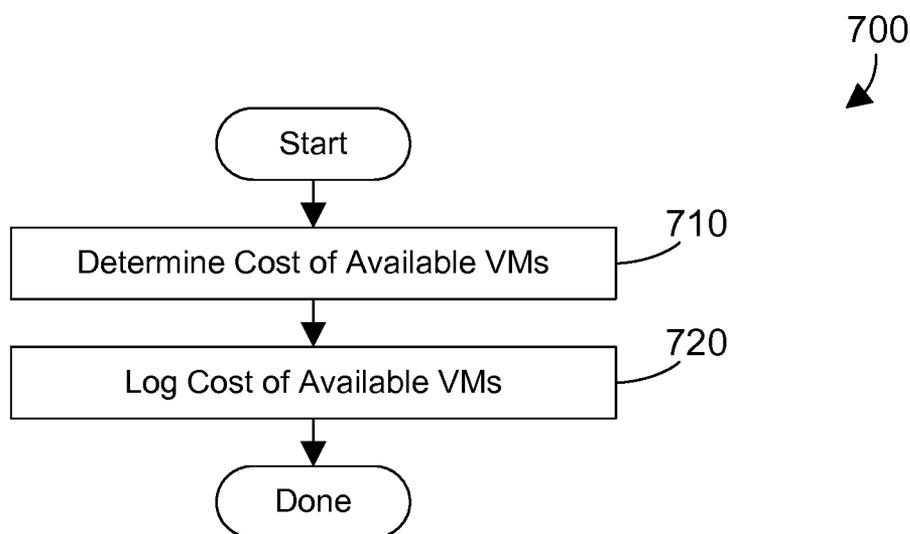

FIG. 7

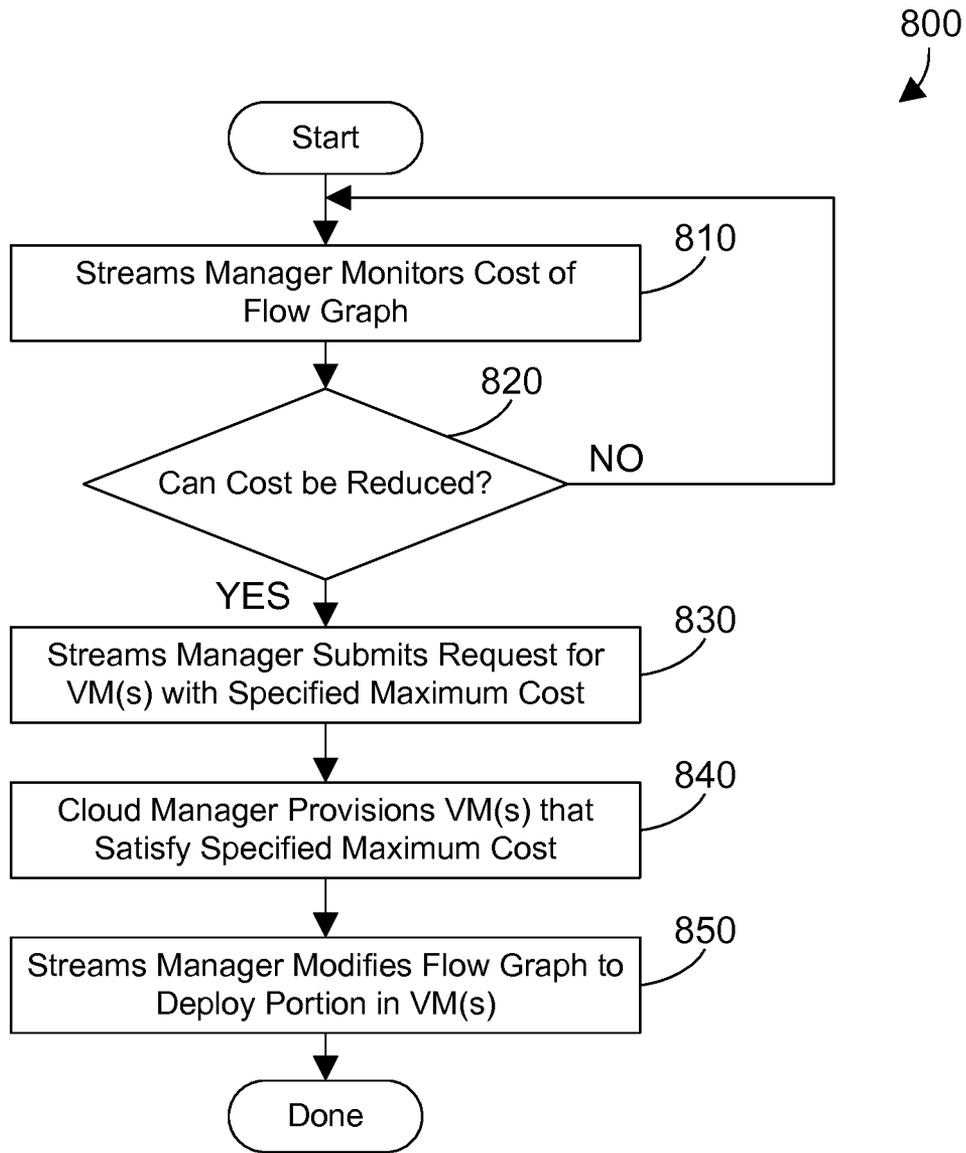

FIG. 8

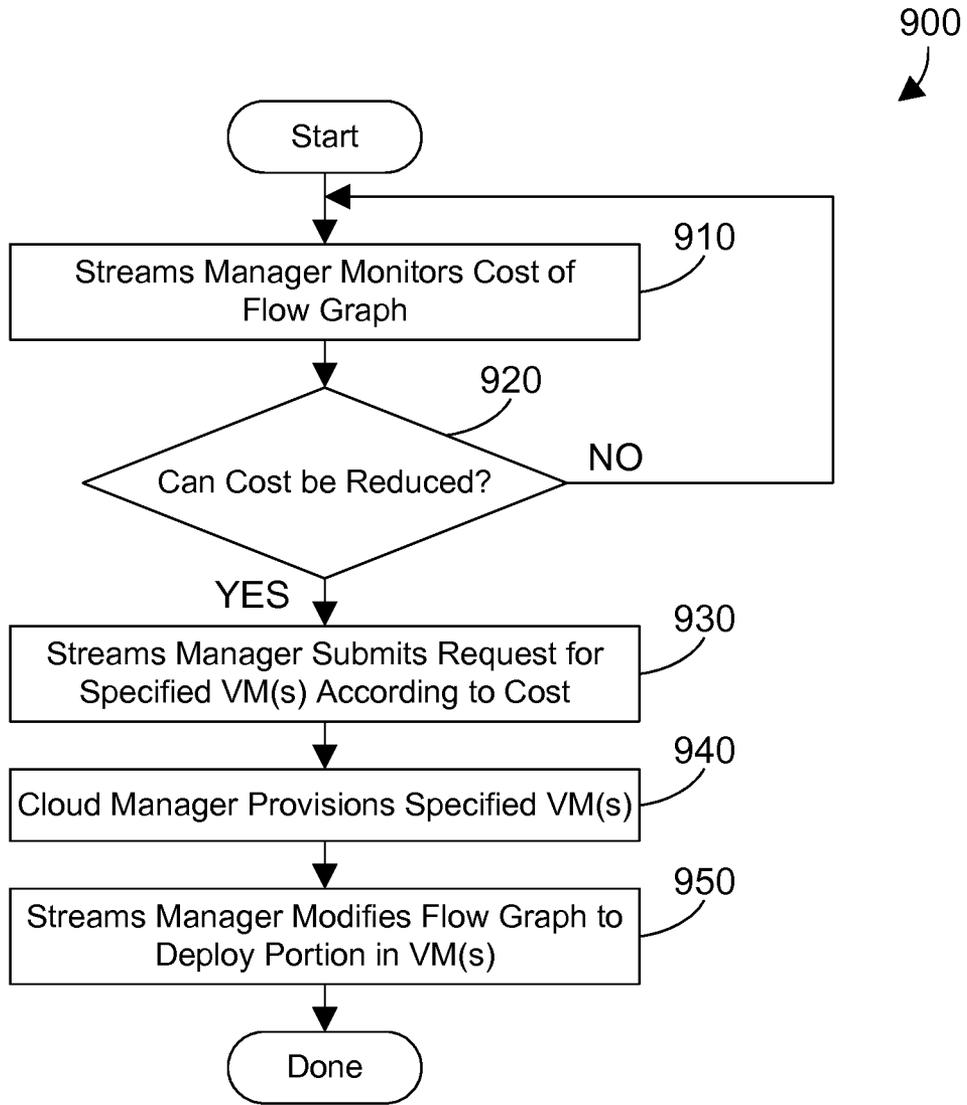

FIG. 9

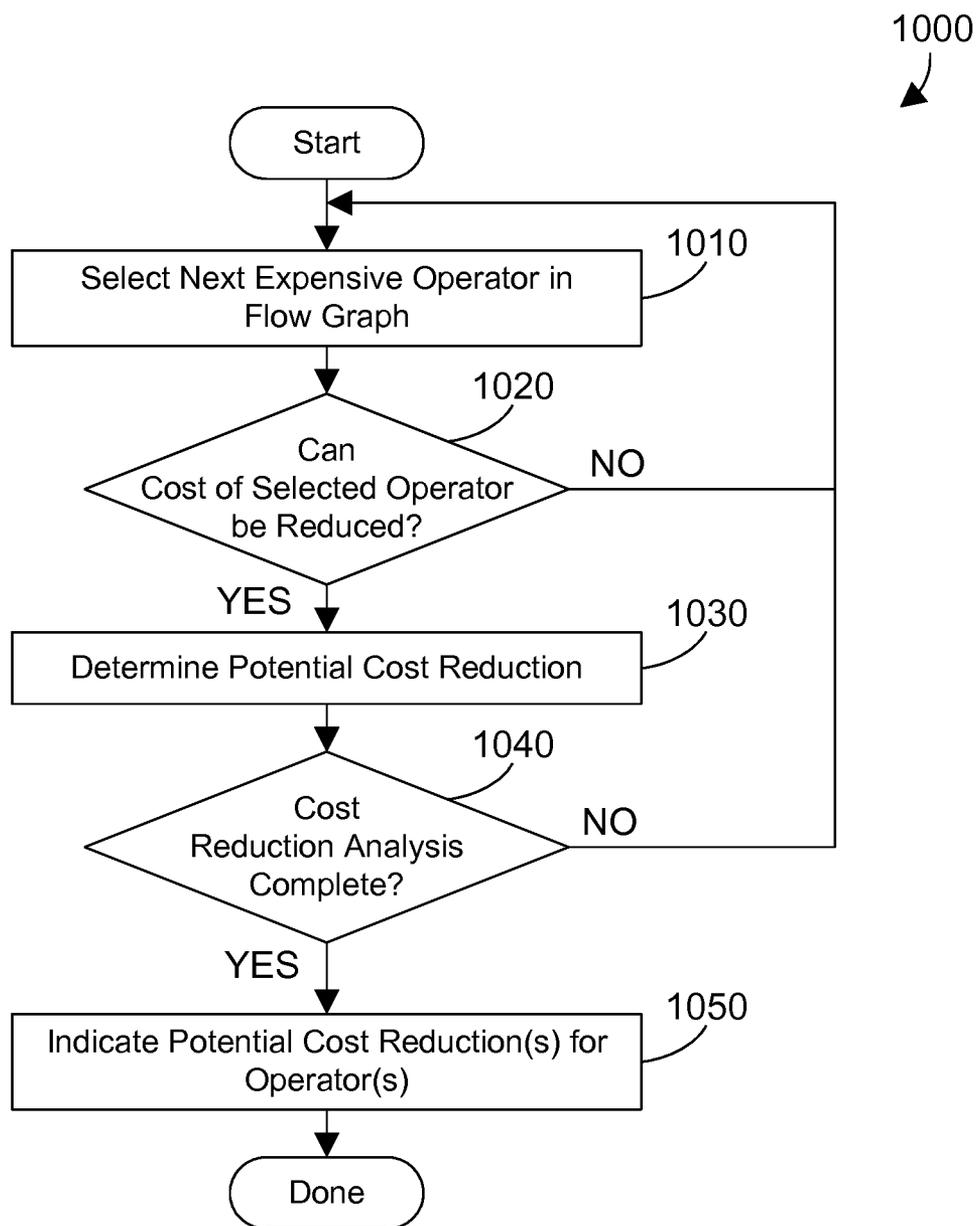

FIG. 10

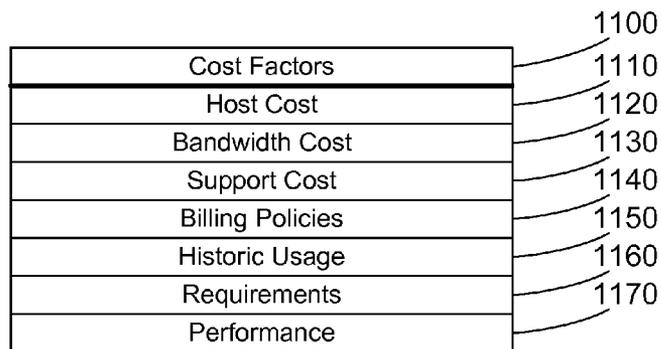

FIG. 11

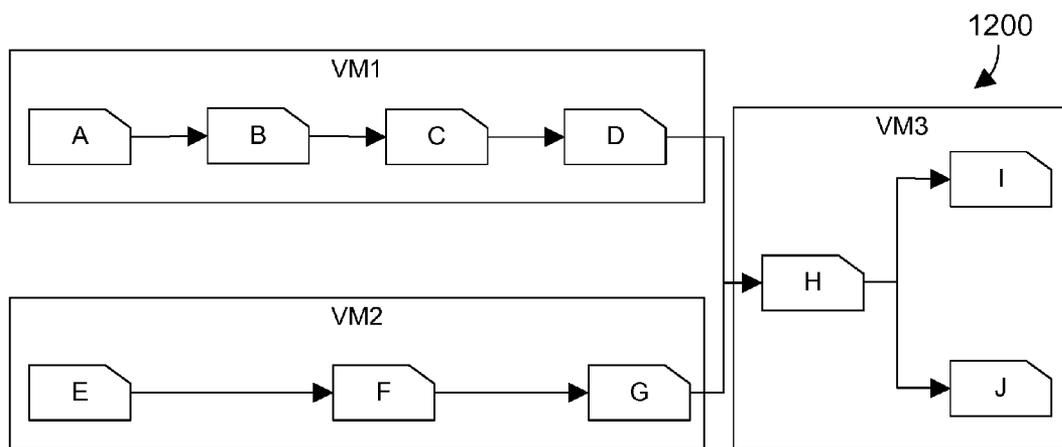

FIG. 12

Cost Thresholds	
VM1	\$1.50/hour
VM2	\$1.00/hour
VM3	\$4.00/hour

FIG. 13

Current Cost	
VM1	\$1.20/hour
VM2	\$1.40/hour
VM3	\$3.50/hour

FIG. 14

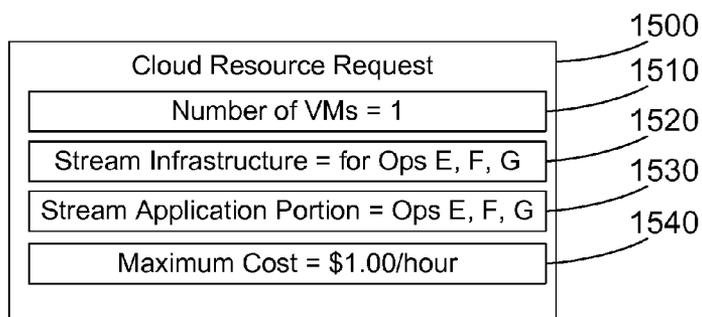

FIG. 15

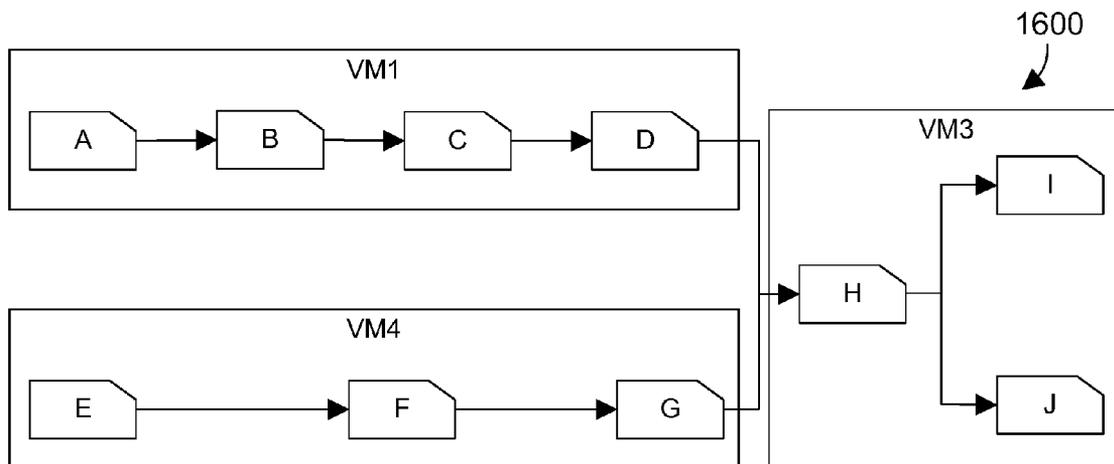

FIG. 16

**DEPLOYING A PORTION OF A STREAMING
APPLICATION TO ONE OR MORE VIRTUAL
MACHINES ACCORDING TO COST**

BACKGROUND

[0001] 1. Technical Field

[0002] This disclosure generally relates to streaming applications, and more specifically relates to lowering the cost of running a streaming application by deploying a portion of the streaming application to one or more virtual machines according to cost of the virtual machines.

[0003] 2. Background Art

[0004] Streaming applications are known in the art, and typically include multiple operators coupled together in a flow graph that process streaming data in near real-time. An operator typically takes in streaming data in the form of data tuples, operates on the tuples in some fashion, and outputs the processed tuples to the next operator. Streaming applications are becoming more common due to the high performance that can be achieved from near real-time processing of streaming data.

[0005] Many streaming applications require significant computer resources, such as processors and memory, to provide the desired near real-time processing of data. However, the workload of a streaming application can vary greatly over time. Allocating on a permanent basis computer resources to a streaming application that would assure the streaming application would always function as desired (i.e., during peak demand) would mean many of those resources would sit idle when the streaming application is processing a workload significantly less than its maximum. Furthermore, what constitutes peak demand at one point in time can be exceeded as the usage of the streaming application increases. For a dedicated system that runs a streaming application, an increase in demand may require a corresponding increase in hardware resources to meet that demand.

BRIEF SUMMARY

[0006] A streams manager monitors cost of one or more VMs hosting a streaming application, determines when cost can be reduced, and requests a cloud manager provision one or more VMs that have a lower cost. In response, the cloud manager provisions the VM(s) that have the lower cost. The streams manager then deploys a portion of the streaming application to the VM(s), thereby reducing the cost of running the streaming application.

[0007] The foregoing and other features and advantages will be apparent from the following more particular description, as illustrated in the accompanying drawings.

BRIEF DESCRIPTION OF THE SEVERAL
VIEWS OF THE DRAWING(S)

[0008] The disclosure will be described in conjunction with the appended drawings, where like designations denote like elements, and:

[0009] FIG. 1 is a block diagram of a cloud computing node;

[0010] FIG. 2 is a block diagram of a cloud computing environment;

[0011] FIG. 3 is a block diagram of abstraction model layers;

[0012] FIG. 4 is a block diagram showing some features of a cloud manager;

[0013] FIG. 5 is a block diagram showing some features of a streams manager;

[0014] FIG. 6 is a flow diagram of a method for a streams manager to request and receive from a cloud manager virtual machines to improve cost of executing a streaming application;

[0015] FIG. 7 is a flow diagram of a method for a cloud manager to log cost for available virtual machines;

[0016] FIG. 8 is a flow diagram of a first exemplary method for improving cost of executing a streaming application by deploying one or more portions of a flow graph to one or more VMs according to a specified maximum cost;

[0017] FIG. 9 is a flow diagram of a second exemplary method for improving cost of executing a streaming application by deploying one or more portions of a flow graph to one or more specified VMs that have a desired cost;

[0018] FIG. 10 is a flow diagram of a method for a streams manager to determine potential cost reductions for operators in a flow graph;

[0019] FIG. 11 is a block diagram showing cost factors that can be taken into account when computing cost for a virtual machine;

[0020] FIG. 12 is a flow diagram of a sample streaming application deployed on three different virtual machines;

[0021] FIG. 13 is a block diagram showing specified cost thresholds for the three virtual machines shown in FIG. 12;

[0022] FIG. 14 is a block diagram showing current cost for the three virtual machines shown in FIG. 12;

[0023] FIG. 15 is a sample cloud resource request for requesting a VM from the cloud manager that has a cost less than a specified maximum cost; and

[0024] FIG. 16 is a block diagram showing the flow diagram in FIG. 12 after the operators E, F and G have been deployed to a different virtual machine to improve the cost of executing the streaming application.

DETAILED DESCRIPTION

[0025] A streams manager monitors cost of one or more VMs hosting a streaming application, determines when cost can be reduced, and requests a cloud manager provision one or more VMs that have a lower cost. In response, the cloud manager provisions the VM(s) that have the lower cost. The streams manager then deploys a portion of the streaming application to the VM(s), thereby reducing the cost of running the streaming application. The cost at issue in this patent application is monetary value of resources, as described in detail below.

[0026] It is understood in advance that although this disclosure includes a detailed description on cloud computing, implementation of the teachings recited herein are not limited to a cloud computing environment. Rather, embodiments of the present invention are capable of being implemented in conjunction with any other type of computing environment now known or later developed.

[0027] Cloud computing is a model of service delivery for enabling convenient, on-demand network access to a shared pool of configurable computing resources (e.g., networks, network bandwidth, servers, processing, memory, storage, applications, virtual machines, and services) that can be rapidly provisioned and released with minimal management effort or interaction with a provider of the service. This cloud model may include at least five characteristics, at least three service models, and at least four deployment models.

[0028] Characteristics are as follows:

[0029] On-demand self-service: a cloud consumer can unilaterally provision computing capabilities, such as server time and network storage, as needed automatically without requiring human interaction with the service's provider.

[0030] Broad network access: capabilities are available over a network and accessed through standard mechanisms that promote use by heterogeneous thin or thick client platforms (e.g., mobile phones, laptops, and PDAs).

[0031] Resource pooling: the provider's computing resources are pooled to serve multiple consumers using a multi-tenant model, with different physical and virtual resources dynamically assigned and reassigned according to demand. There is a sense of location independence in that the consumer generally has no control or knowledge over the exact location of the provided resources but may be able to specify location at a higher level of abstraction (e.g., country, state, or datacenter).

[0032] Rapid elasticity: capabilities can be rapidly and elastically provisioned, in some cases automatically, to quickly scale out and rapidly released to quickly scale in. To the consumer, the capabilities available for provisioning often appear to be unlimited and can be purchased in any quantity at any time.

[0033] Measured service: cloud systems automatically control and optimize resource use by leveraging a metering capability at some level of abstraction appropriate to the type of service (e.g., storage, processing, bandwidth, and active user accounts). Resource usage can be monitored, controlled, and reported providing transparency for both the provider and consumer of the utilized service.

[0034] Service Models are as follows:

[0035] Software as a Service (SaaS): the capability provided to the consumer is to use the provider's applications running on a cloud infrastructure. The applications are accessible from various client devices through a thin client interface such as a web browser (e.g., web-based e-mail). The consumer does not manage or control the underlying cloud infrastructure including network, servers, operating systems, storage, or even individual application capabilities, with the possible exception of limited user-specific application configuration settings.

[0036] Platform as a Service (PaaS): the capability provided to the consumer is to deploy onto the cloud infrastructure consumer-created or acquired applications created using programming languages and tools supported by the provider. The consumer does not manage or control the underlying cloud infrastructure including networks, servers, operating systems, or storage, but has control over the deployed applications and possibly application hosting environment configurations.

[0037] Infrastructure as a Service (IaaS): the capability provided to the consumer is to provision processing, storage, networks, and other fundamental computing resources where the consumer is able to deploy and run arbitrary software, which can include operating systems and applications. The consumer does not manage or control the underlying cloud infrastructure but has control over operating systems, storage, deployed applications, and possibly limited control of select networking components (e.g., host firewalls).

[0038] Deployment Models are as follows:

[0039] Private cloud: the cloud infrastructure is operated solely for an organization. It may be managed by the organization or a third party and may exist on-premises or off-premises.

[0040] Community cloud: the cloud infrastructure is shared by several organizations and supports a specific community that has shared concerns (e.g., mission, security requirements, policy, and compliance considerations). It may be managed by the organizations or a third party and may exist on-premises or off-premises.

[0041] Public cloud: the cloud infrastructure is made available to the general public or a large industry group and is owned by an organization selling cloud services.

[0042] Hybrid cloud: the cloud infrastructure is a composition of two or more clouds (private, community, or public) that remain unique entities but are bound together by standardized or proprietary technology that enables data and application portability (e.g., cloud bursting for loadbalancing between clouds).

[0043] A cloud computing environment is service oriented with a focus on statelessness, low coupling, modularity, and semantic interoperability. At the heart of cloud computing is an infrastructure comprising a network of interconnected nodes.

[0044] Referring now to FIG. 1, a block diagram of an example of a cloud computing node is shown. Cloud computing node **100** is only one example of a suitable cloud computing node and is not intended to suggest any limitation as to the scope of use or functionality of embodiments of the invention described herein. Regardless, cloud computing node **100** is capable of being implemented and/or performing any of the functionality set forth hereinabove.

[0045] In cloud computing node **100** there is a computer system/server **110**, which is operational with numerous other general purpose or special purpose computing system environments or configurations. Examples of well-known computing systems, environments, and/or configurations that may be suitable for use with computer system/server **110** include, but are not limited to, personal computer systems, server computer systems, tablet computer systems, thin clients, thick clients, handheld or laptop devices, multiprocessor systems, microprocessor-based systems, set top boxes, programmable consumer electronics, network PCs, minicomputer systems, mainframe computer systems, and distributed cloud computing environments that include any of the above systems or devices, and the like.

[0046] Computer system/server **110** may be described in the general context of computer system executable instructions, such as program modules, being executed by a computer system. Generally, program modules may include routines, programs, objects, components, logic, data structures, and so on that perform particular tasks or implement particular abstract data types. Computer system/server **110** may be practiced in distributed cloud computing environments where tasks are performed by remote processing devices that are linked through a communications network. In a distributed cloud computing environment, program modules may be located in both local and remote computer system storage media including memory storage devices.

[0047] As shown in FIG. 1, computer system/server **110** in cloud computing node **100** is shown in the form of a general-purpose computing device. The components of computer system/server **110** may include, but are not limited to, one or

more processors or processing units **120**, a system memory **130**, and a bus **122** that couples various system components including system memory **130** to processing unit **120**.

[0048] Bus **122** represents one or more of any of several types of bus structures, including a memory bus or memory controller, a peripheral bus, an accelerated graphics port, and a processor or local bus using any of a variety of bus architectures. By way of example, and not limitation, such architectures include Industry Standard Architecture (ISA) bus, Micro Channel Architecture (MCA) bus, Enhanced ISA (EISA) bus, Video Electronics Standards Association (VESA) local bus, and Peripheral Component Interconnect (PCI) bus.

[0049] Computer system/server **110** typically includes a variety of computer system readable media. Such media may be any available media that is accessible by computer system/server **110**, and it includes both volatile and non-volatile media, removable and non-removable media. An example of removable media is shown in FIG. **1** to include a Digital Video Disc (DVD) **192**.

[0050] System memory **130** can include computer system readable media in the form of volatile or non-volatile memory, such as firmware **132**. Firmware **132** provides an interface to the hardware of computer system/server **110**. System memory **130** can also include computer system readable media in the form of volatile memory, such as random access memory (RAM) **134** and/or cache memory **136**. Computer system/server **110** may further include other removable/non-removable, volatile/non-volatile computer system storage media. By way of example only, storage system **140** can be provided for reading from and writing to a non-removable, non-volatile magnetic media (not shown and typically called a “hard drive”). Although not shown, a magnetic disk drive for reading from and writing to a removable, non-volatile magnetic disk (e.g., a “floppy disk”), and an optical disk drive for reading from or writing to a removable, non-volatile optical disk such as a CD-ROM, DVD-ROM or other optical media can be provided. In such instances, each can be connected to bus **122** by one or more data media interfaces. As will be further depicted and described below, memory **130** may include at least one program product having a set (e.g., at least one) of program modules that are configured to carry out the functions described in more detail below.

[0051] Program/utility **150**, having a set (at least one) of program modules **152**, may be stored in memory **130** by way of example, and not limitation, as well as an operating system, one or more application programs, other program modules, and program data. Each of the operating system, one or more application programs, other program modules, and program data or some combination thereof, may include an implementation of a networking environment. Program modules **152** generally carry out the functions and/or methodologies of embodiments of the invention as described herein.

[0052] Computer system/server **110** may also communicate with one or more external devices **190** such as a keyboard, a pointing device, a display **180**, a disk drive, etc.; one or more devices that enable a user to interact with computer system/server **110**; and/or any devices (e.g., network card, modem, etc.) that enable computer system/server **110** to communicate with one or more other computing devices. Such communication can occur via Input/Output (I/O) interfaces **170**. Still yet, computer system/server **110** can communicate with one or more networks such as a local area network (LAN), a general wide area network (WAN), and/or a public

network (e.g., the Internet) via network adapter **160**. As depicted, network adapter **160** communicates with the other components of computer system/server **110** via bus **122**. It should be understood that although not shown, other hardware and/or software components could be used in conjunction with computer system/server **110**. Examples, include, but are not limited to: microcode, device drivers, redundant processing units, external disk drive arrays, Redundant Array of Independent Disk (RAID) systems, tape drives, data archival storage systems, etc.

[0053] Referring now to FIG. **2**, illustrative cloud computing environment **200** is depicted. As shown, cloud computing environment **200** comprises one or more cloud computing nodes **100** with which local computing devices used by cloud consumers, such as, for example, personal digital assistant (PDA) or cellular telephone **210A**, desktop computer **210B**, laptop computer **210C**, and/or automobile computer system **210N** may communicate. Nodes **100** may communicate with one another. They may be grouped (not shown) physically or virtually, in one or more networks, such as Private, Community, Public, or Hybrid clouds as described hereinabove, or a combination thereof. This allows cloud computing environment **200** to offer infrastructure, platforms and/or software as services for which a cloud consumer does not need to maintain resources on a local computing device. It is understood that the types of computing devices **210A-N** shown in FIG. **2** are intended to be illustrative only and that computing nodes **100** and cloud computing environment **200** can communicate with any type of computerized device over any type of network and/or network addressable connection (e.g., using a web browser).

[0054] Referring now to FIG. **3**, a set of functional abstraction layers provided by cloud computing environment **200** in FIG. **2** is shown. It should be understood in advance that the components, layers, and functions shown in FIG. **3** are intended to be illustrative only and the disclosure and claims are not limited thereto. As depicted, the following layers and corresponding functions are provided.

[0055] Hardware and software layer **310** includes hardware and software components. Examples of hardware components include mainframes, in one example IBM System z systems; RISC (Reduced Instruction Set Computer) architecture based servers, in one example IBM System p systems; IBM System x systems; IBM BladeCenter systems; storage devices; networks and networking components. Examples of software components include network application server software, in one example IBM WebSphere® application server software; and database software, in one example IBM DB2® database software. IBM, System z, System p, System x, BladeCenter, WebSphere, and DB2 are trademarks of International Business Machines Corporation registered in many jurisdictions worldwide.

[0056] Virtualization layer **320** provides an abstraction layer from which the following examples of virtual entities may be provided: virtual servers; virtual storage; virtual networks, including virtual private networks; virtual applications and operating systems; and virtual clients.

[0057] In one example, management layer **330** may provide the functions described below. Resource provisioning provides dynamic procurement of computing resources and other resources that are utilized to perform tasks within the cloud computing environment. Metering and Pricing provide cost tracking as resources are utilized within the cloud computing environment, and billing or invoicing for consumption

of these resources. In one example, these resources may comprise application software licenses. Security provides identity verification for cloud consumers and tasks, as well as protection for data and other resources. User portal provides access to the cloud computing environment for consumers and system administrators. Service level management provides cloud computing resource allocation and management such that required service levels are met. Service Level Agreement (SLA) planning and fulfillment provides pre-arrangement for, and procurement of, cloud computing resources for which a future requirement is anticipated in accordance with an SLA. A cloud manager **350** is representative of a cloud manager as described in more detail below. While the cloud manager **350** is shown in FIG. 3 to reside in the management layer **330**, cloud manager **350** can span all of the levels shown in FIG. 3, as discussed below.

[0058] Workloads layer **340** provides examples of functionality for which the cloud computing environment may be utilized. Examples of workloads and functions which may be provided from this layer include: mapping and navigation; software development and lifecycle management; virtual classroom education delivery; data analytics processing; transaction processing; and a streams manager **360**, as discussed in more detail below.

[0059] The present invention may be a system, a method, and/or a computer program product. The computer program product may include a computer readable storage medium (or media) having computer readable program instructions thereon for causing a processor to carry out aspects of the present invention.

[0060] The computer readable storage medium can be a tangible device that can retain and store instructions for use by an instruction execution device. The computer readable storage medium may be, for example, but is not limited to, an electronic storage device, a magnetic storage device, an optical storage device, an electromagnetic storage device, a semiconductor storage device, or any suitable combination of the foregoing. A non-exhaustive list of more specific examples of the computer readable storage medium includes the following: a portable computer diskette, a hard disk, a random access memory (RAM), a read-only memory (ROM), an erasable programmable read-only memory (EPROM or Flash memory), a static random access memory (SRAM), a portable compact disc read-only memory (CD-ROM), a digital versatile disk (DVD), a memory stick, a floppy disk, a mechanically encoded device such as punch-cards or raised structures in a groove having instructions recorded thereon, and any suitable combination of the foregoing. A computer readable storage medium, as used herein, is not to be construed as being transitory signals per se, such as radio waves or other freely propagating electromagnetic waves, electromagnetic waves propagating through a waveguide or other transmission media (e.g., light pulses passing through a fiber-optic cable), or electrical signals transmitted through a wire.

[0061] Computer readable program instructions described herein can be downloaded to respective computing/processing devices from a computer readable storage medium or to an external computer or external storage device via a network, for example, the Internet, a local area network, a wide area network and/or a wireless network. The network may comprise copper transmission cables, optical transmission fibers, wireless transmission, routers, firewalls, switches, gateway computers and/or edge servers. A network adapter card or network interface in each computing/processing device

receives computer readable program instructions from the network and forwards the computer readable program instructions for storage in a computer readable storage medium within the respective computing/processing device.

[0062] Computer readable program instructions for carrying out operations of the present invention may be assembler instructions, instruction-set-architecture (ISA) instructions, machine instructions, machine dependent instructions, microcode, firmware instructions, state-setting data, or either source code or object code written in any combination of one or more programming languages, including an object oriented programming language such as Smalltalk, C++ or the like, and conventional procedural programming languages, such as the "C" programming language or similar programming languages. The computer readable program instructions may execute entirely on the user's computer, partly on the user's computer, as a stand-alone software package, partly on the user's computer and partly on a remote computer or entirely on the remote computer or server. In the latter scenario, the remote computer may be connected to the user's computer through any type of network, including a local area network (LAN) or a wide area network (WAN), or the connection may be made to an external computer (for example, through the Internet using an Internet Service Provider). In some embodiments, electronic circuitry including, for example, programmable logic circuitry, field-programmable gate arrays (FPGA), or programmable logic arrays (PLA) may execute the computer readable program instructions by utilizing state information of the computer readable program instructions to personalize the electronic circuitry, in order to perform aspects of the present invention.

[0063] Aspects of the present invention are described herein with reference to flowchart illustrations and/or block diagrams of methods, apparatus (systems), and computer program products according to embodiments of the invention. It will be understood that each block of the flowchart illustrations and/or block diagrams, and combinations of blocks in the flowchart illustrations and/or block diagrams, can be implemented by computer readable program instructions.

[0064] These computer readable program instructions may be provided to a processor of a general purpose computer, special purpose computer, or other programmable data processing apparatus to produce a machine, such that the instructions, which execute via the processor of the computer or other programmable data processing apparatus, create means for implementing the functions/acts specified in the flowchart and/or block diagram block or blocks. These computer readable program instructions may also be stored in a computer readable storage medium that can direct a computer, a programmable data processing apparatus, and/or other devices to function in a particular manner, such that the computer readable storage medium having instructions stored therein comprises an article of manufacture including instructions which implement aspects of the function/act specified in the flowchart and/or block diagram block or blocks.

[0065] The computer readable program instructions may also be loaded onto a computer, other programmable data processing apparatus, or other device to cause a series of operational steps to be performed on the computer, other programmable apparatus or other device to produce a computer implemented process, such that the instructions which execute on the computer, other programmable apparatus, or other device implement the functions/acts specified in the flowchart and/or block diagram block or blocks.

[0066] The flowchart and block diagrams in the Figures illustrate the architecture, functionality, and operation of possible implementations of systems, methods, and computer program products according to various embodiments of the present invention. In this regard, each block in the flowchart or block diagrams may represent a module, segment, or portion of instructions, which comprises one or more executable instructions for implementing the specified logical function(s). In some alternative implementations, the functions noted in the block may occur out of the order noted in the figures. For example, two blocks shown in succession may, in fact, be executed substantially concurrently, or the blocks may sometimes be executed in the reverse order, depending upon the functionality involved. It will also be noted that each block of the block diagrams and/or flowchart illustration, and combinations of blocks in the block diagrams and/or flowchart illustration, can be implemented by special purpose hardware-based systems that perform the specified functions or acts or carry out combinations of special purpose hardware and computer instructions.

[0067] FIG. 4 shows one suitable example of the cloud manager 350 shown in FIG. 3. The cloud manager 350 includes a cloud provisioning mechanism 410 that includes a resource request interface 420. The resource request interface 420 allows a software entity, such as the streams manager 360, to request virtual machines from the cloud manager 350 without human intervention. The cloud manager 350 also includes a user interface 430 that allows a user to interact with the cloud manager to perform any suitable function, including provisioning of VMs, destruction of VMs, performance analysis of the cloud, etc. The difference between the resource request interface 420 and the user interface 430 is a user must manually use the user interface 430 to perform functions specified by the user, while the resource request interface 420 may be used by a software entity to request provisioning of cloud resources by the cloud mechanism 350 without input from a human user.

[0068] The cloud manager 350 also includes a cost monitor 440. The cost monitor 440 includes a virtual machine cost computation mechanism 450, one or more cost factors 460, and virtual machine cost logs 470. The virtual machine cost computation mechanism 450 computes the cost of virtual machines according to the cost factors 460, discussed in more detail below. The cost of available virtual machines is logged to one or more VM cost logs 470. By logging the cost of available virtual machines to one or more VM cost logs 470, the cloud manager can easily determine the cost for available virtual machines based on the logged cost rather than having to compute the cost for each virtual machine when a virtual machine is requested. Of course, the one or more VM cost logs 470 are optional, because the VM cost computation mechanism 450 could alternatively determine cost of available hosts after a virtual machine is requested. Of course, cloud manager 350 could include many other features and functions known in the art that are not shown in FIG. 4.

[0069] FIG. 5 shows one suitable example of the streams manager 360 shown in FIG. 3. The streams manager 360 is software that manages one or more streaming applications, including creating operators and data flow connections between operators in a flow graph that represents a streaming application. The streams manager 360 includes a stream cost monitor 510 that includes a VM cost monitor mechanism 520, one or more cost thresholds 522, and one or more VM cost logs 524. The VM cost monitor mechanism 520 monitors the

cost of VMs used to execute a streaming application. Cost thresholds 522 includes one or more cost thresholds that each specifies a maximum cost for one or more virtual machines. For example, if a streaming application is executed by three VMs, the cost thresholds 522 could include three different cost thresholds, one for each VM. In the alternative, a single cost threshold 522 could specify maximum cost for any VM in the streaming application. Cost threshold(s) 520 can include static thresholds, such as a cost in a given currency for a given time period, and can also include any suitable heuristic for specifying cost of a streaming application as a whole or for specifying cost of one or more operators in a streaming application or one or more operators deployed to a virtual machine. Cost thresholds 520 may include, for example, different thresholds and metrics at the operator level, at the level of a group of operators, and/or at the level of the overall performance of the streaming application.

[0070] One or more VM cost logs 524 may include cost of VMs used to execute a streaming application, and may also include cost of one or more VMs available to the cloud manager 350. The cost of VMs available to the cloud manager could be copied from the VM cost logs 470 in the cloud manager to the VM cost logs 524 in the streams manager. Making the cost of available VMs available to the streams manager gives the streams manager some flexibility in determining how the request VMs to reduce the cost of executing a streaming application, as discussed below with reference to FIGS. 8 and 9.

[0071] The streams manager 360 determines a portion of the streaming application to deploy to one or more VMs. Note the portion of the streaming application may be a single operator or may be multiple operators. The streams manager 360 uses a cloud resource request mechanism 530 to formulate a cloud resource request 540, which can include information such as a number of VMs to provision 550, stream infrastructure needed in each VM 560, a stream application portion 570 (e.g., one or more operators) for each VM, and other information such as a maximum cost or identifiers of one or more VMs to provision 580.

[0072] The cloud resource request can be formatted in any suitable way. A simple example will illustrate two suitable ways for formatting a cloud resource request. Let's assume the streams manager determines it needs two VMs, where both have common stream infrastructure, with a first of the VMs hosting operator A and the second of the VMs hosting operator B. The cloud resource request 540 in FIG. 5 could specify two VMs at 550, could specify the common stream infrastructure, such as an operating system and middleware, at 560, could specify operator A and operator B at 570, and could specify a maximum cost at 580. In response, the cloud manager would provision two VMs on one or two servers with the common stream infrastructure that have a cost less than the specified maximum cost, with the first of the VMs hosting operator A and the second of the VMs hosting operator B. In the alternative, the cloud resource request 540 could be formulated such that each VM is specified with its corresponding stream infrastructure and stream application portion. In this configuration, the cloud resource request would specify a first VM with the common stream infrastructure and operator A with a maximum cost for the first VM, and a second VM with the common stream infrastructure and operator B with a maximum cost for the second VM.

[0073] Referring to FIG. 6, a method 600 shows one suitable example for reducing cost of executing a streaming

application, and is preferably performed by the streams manager **360** interacting with the cloud manager **350**. The streams manager requests resources, such as VMs, from the cloud manager based on cost (step **610**). The cloud manager provisions the VMs (step **620**). The streams manager then deploys a portion of the flow graph to the VMs (step **630**). When the streaming application is not initially hosted in the cloud, the result will be a hybrid implementation of the streams application, with some portions hosted on a dedicated computer system and other portions hosted by one or more VMs in the cloud.

[**0074**] FIG. 7 shows one suitable example of a method **700** for a cloud manager to log cost information for VMs which it can provision. The cost of available VMs is determined (step **710**). The cost of VMs in a public cloud, such as Amazon's Elastic Compute Cloud (EC2), is easy to determine because the cost of VMs in public clouds is published by the cloud provider. The cost of the available VMs is also logged (step **720**). The cost log of available VMs in step **720** can be the VM cost logs **470** shown in FIG. 4. By logging cost information for available VMs, the cloud manager can fulfill requests from the streams manager to deploy one or more operators to virtual machines based on cost without the need to determine cost of available VMs after the request is received.

[**0075**] Referring to FIG. 8, a first method **800** shows how a streams manager can reduce the cost of executing a streaming application by deploying a portion of the streaming application to one or more VMs in a cloud. Method **800** is one specific implementation for method **600** shown in FIG. 6. The streams manager monitors cost of a flow graph corresponding to a streaming application (step **810**). When the cost cannot be reduced (step **820**=NO), method **800** loops back to step **810** and continues. When the cost can be reduced (step **820**=YES), the streams manager generates and submits to the cloud manager a request for one or more VMs with a specified maximum cost (step **830**). Cloud resource request **540** shown in FIG. 5 and discussed above is one suitable example of such a request. In response to receiving the request from the streams manager, the cloud manager provisions one or more VMs that satisfy the specified maximum cost (step **840**). The streams manager then modifies the flow graph to deploy a portion of the flow graph to the one or more VMs (step **850**). Method **800** is then done.

[**0076**] Referring to FIG. 9, a second method **900** shows how a streams manager can reduce the cost of executing a streaming application by deploying a portion of the streaming application to one or more VMs in a cloud. Method **900** is another specific implementation for method **600** shown in FIG. 6. The streams manager monitors cost of a flow graph corresponding to a streaming application (step **910**). When the cost cannot be reduced (step **920**=NO), method **900** loops back to step **910** and continues. When the cost can be reduced (step **920**=YES), the streams manager generates and submits to the cloud manager a request for one or more specified VMs (step **930**). Cloud resource request **540** shown in FIG. 5 and discussed above is one suitable example of such a request. In response to receiving the request from the streams manager, the cloud manager provisions the one or more specified VMs (step **940**). The streams manager then modifies the flow graph to deploy a portion of the flow graph to the one or more VMs (step **950**). Method **900** is then done.

[**0077**] One of the differences between method **800** in FIG. 8 and method **900** in FIG. 9 is whether the streams manager or the cloud manager selects the one or more VMs. In method

800 in FIG. 8, the streams manager simply specifies a maximum cost for each VM, and the cloud manager then selects the one or more VMs that satisfy the specified maximum cost. In method **900** in FIG. 9, in contrast, the streams manager identifies from its one or more VM cost logs **524** the cost of available VMs, then specifies to the cloud manager a VM identifier. Note the identifier does not necessarily specify a particular VM, but in the most preferred implementation specifies characteristics or attributes of a particular VM. For example, if the one or more VM cost logs **524** indicate a VM deployed to Amazon's EC2 has a desired cost less than the current cost of a VM executing a portion of the streaming application, the VM identifier **580** in the cloud resource request **540** could specify a VM in EC2. In an alternative implementation, the one or more VM cost logs **524** may include cost for specific VMs available to the cloud manager **350**, which would allow the VM identifier **580** to specify a particular VM.

[**0078**] FIG. 10 shows a method **1000** that could be implemented to determine whether cost can be reduced, as shown at **820** in FIGS. 8 and **920** in FIG. 9. The streams manager initially selects the most expensive operator in the flow graph (step **1010**). Most expensive operator in this context means the operator that uses the highest monetary value of resources. When the cost of the selected operator cannot be reduced (step **1020**=NO), method **1000** loops back to step **1010** and continues. When cost of the selected operator can be reduced (step **1020**=YES), the potential cost reduction is determined (step **1030**). When the cost reduction analysis is not complete (step **1040**=NO), method **1000** loops back and continues by selecting the next most-expensive operator (step **1010**). When the cost reduction analysis is complete (step **1040**=YES), the potential cost reduction(s) for the selected operator(s) is indicated to the streams manager (step **1050**). Method **1000** is then done. Note the determination of when the cost reduction analysis is complete in step **1040** can be made in many different ways. For example, the cost reduction analysis could be complete when enough operators have been processed to get the overall cost of a portion of the streaming application or the streaming application as a whole below some specified cost threshold. In the alternative, the cost reduction analysis could be complete when a specified number of operators have been selected and processed. In yet another alternative, the cost reduction analysis could be complete based on the time spent executing method **1000**. In still another alternative, it may be impossible to reduce the cost of a portion of the streaming application or the streaming application as a whole, so the cost reduction analysis could be complete once all operators have been analyzed, or once all operators that exceed some cost threshold have been analyzed, even if there are no potential cost reductions. The disclosure and claims expressly extend to any suitable way for determining when the cost reduction analysis is complete.

[**0079**] The cost of a VM can depend on many different factors, some of which are shown by way of example in FIG. 11. Cost factors **1100** shown in FIG. 11 include host cost **1110**, which is the cost of hosting the VM. The bandwidth cost **1120** is a cost of the bandwidth used to and from the VM. Support cost **1130** may also be taken into account, which can include any cost associated with supporting the VM. For example, there is a minimum power a host computer system requires even if there one only one VM running on the host computer system. This cost can vary widely since the host may be a stand-alone server that can host a limited number of

VMs or may be a massively parallel computer system that can support many VMs. In addition, support cost **1130** can indicate whether a server can be shut down by moving a VM to a different server, and can also indicate whether a server must be started to host a VM. While these incremental costs may be less relevant to immediate optimization, they would be valuable input into longer term planning for internal support. Billing policies **1140** can influence a cost-based decision. Billing policies **1140** can include such things as discounts and overage charges. Discounts could be available based on number of operators or number of VMs. For example, if discounts for increased usage are available, the cost analysis can look at moving enough operators to get the discount, even though their current individual cost is less where they are. In the case of overage charges, the cost of a VM can be partially determined by the overages charges. For example, by ensuring enough buffer remains to ensure the overage is unlikely to occur, this can influence the cost of potential cost reductions.

[0080] Historic usage **1150** is another potential cost factor. Historic usage of the host can be used to determine if a peak usage is upcoming or if it will have excess capacity that allows the cost estimate to be adjusted. This could require that a streams manager know how long an operator is needed. For example, if a parallel operator is added to increase throughput, the historic usage can indicate the times when the parallel operator was needed. Another function of historic usage **1150** is to set an expiration for logged costs. Thus, a cost is specified with an expiration time. As the expiration time approaches or is reached, a cost analysis could be repeated to determine if one or more operators should be moved.

[0081] Requirements **1160** can also be a potential cost factor. Requirements **1160** can be anything that is a requirement for one or more operators in the streaming application or for the streaming application as a whole. For example, when one or more operators process sensitive or confidential data, the operator(s) could be prevented from being moved to a public cloud. In the alternative, the operator(s) could be moved to a public cloud as long as the sensitive portion of the tuple is encrypted as it leaves the private cloud and is decrypted when it returns from the public cloud. In this scenario, the cost of operators to perform the encryption and decryption may be included in the cost for moving the operator(s) to the public cloud.

[0082] Performance **1170** can be another potential cost factor. For example, due to performance or reliability requirements, one instance of the operator in a private cloud may need to be replaced with two instances of the operator in a public cloud. The cost analysis can include the cost of the additional operator as dictated by performance **1170**.

[0083] A simple example is provided in FIGS. **12-16** to illustrate some of the concepts discussed above. Referring to FIG. **12**, a streaming application **1200** includes operators A, B, C, D, E, F, G, H, I and J as shown. Operator A originates a stream of tuples, which is processed by operator B, which outputs tuples. The tuples from operator B are processed by operator C, which outputs tuples to operator D, which processes the tuples and outputs its tuples to operator H. In similar fashion, operator E originates a stream of tuples, which is processed by operator F, which outputs tuples that are processed by operator G, which outputs tuples to operator H. Note that operator H receives tuples from both operator D and operator G. Operator H processes the tuples it receives from operator D and from operator G, and outputs its tuples to operators I and J. This example assumes the streaming appli-

cation **1200** has operators deployed to three different VMs, as shown in FIG. **12**, namely: operators A, B, C and D are deployed to VM1; operators E, F and G are deployed to VM2; and operators H, I and J are deployed to VM3.

[0084] We assume there are three cost thresholds specified for VM1, VM2 and VM3, as shown in FIG. **13**. The cost thresholds in FIG. **13** are suitable examples of cost thresholds **522** shown in FIG. **5**, expressed in U.S. dollars per hour. Of course, other currencies and other units could be used. For example, suitable cost thresholds could be expressed in Japanese Yen per processor cycle, Euros per unit of memory, or Mexican Peso per unit of input/outputs (I/Os). These cost thresholds in FIG. **13** are preferably maximum cost for each VM. The current cost of each VM is shown in FIG. **14**. The current cost for each VM is preferably computed by the VM cost monitor mechanism **520** shown in FIG. **5**. When current cost exceeds the cost thresholds in FIG. **13**, the streams manager will take action in an attempt to reduce the cost so each VM operates under its specified cost threshold shown in FIG. **13**. For this example, we see the current cost of \$1.40 per hour for VM2 in FIG. **14** is greater than the cost threshold \$1.00 per hour for VM2 in FIG. **13**. As a result, the streams manager determines that deploying VM2 to a server in a cloud results in a lower cost. The streams manager then generates a cloud resource request **1500** as shown in FIG. **15**. Note that cloud resource request **1500** is one suitable example for cloud resource request **540** in FIG. **5**. Cloud resource request **1500** in FIG. **15** specifies to create one VM at **1510**, specifies stream infrastructure (i.e., operating system and middleware) for operators E, F and G at **1520**, specifies that operators E, F and G are to be deployed on the one requested VM at **1530**, and specifies a maximum cost of \$1.00 per hour at **1540**. In response, the cloud manager finds a VM that has a cost less than the specified maximum cost of \$1.50 per hour, provisions the requested VM, and returns the requested VM to the streams manager. In response, the streams manager deploys operators E, F and G on the newly provisioned VM in the cloud, which is shown as VM4 in FIG. **16**. The flow diagram **1600** shows the streaming application in FIG. **12** after the operators that were deployed to VM2 in FIG. **12** have been moved to VM4.

[0085] A streams manager monitors cost of one or more VMs hosting a streaming application, determines when cost can be reduced, and requests a cloud manager provision one or more VMs that have a lower cost. In response, the cloud manager provisions the VM(s) that have the lower cost. The streams manager then deploys a portion of the streaming application to the VM(s), thereby reducing the cost of running the streaming application.

[0086] One skilled in the art will appreciate that many variations are possible within the scope of the claims. Thus, while the disclosure is particularly shown and described above, it will be understood by those skilled in the art that these and other changes in form and details may be made therein without departing from the spirit and scope of the claims.

1. An apparatus comprising:
 - at least one processor;
 - a memory coupled to the at least one processor;
 - a streaming application residing in the memory and executed by the at least one processor, the streaming application comprising a flow graph that includes a plurality of operators that process a plurality of data tuples; and

a streams manager residing in the memory and executed by the at least one processor, the streams manager determining cost of executing the streaming application, and when cost of executing at least a portion of the streaming application can be reduced, the streams manager submits a request to a cloud manager to provision at least one virtual machine according to cost, and after the cloud manager provisions the at least one virtual machine, the streams manager modifies the flow graph to deploy the portion of the streaming application to the at least one virtual machine.

2. The apparatus of claim 1 wherein the streams manager specifies in the request to the cloud manager a maximum cost, wherein the cloud manager selects and provisions the at least one virtual machine that has a cost less than the maximum cost specified in the request.

3. The apparatus of claim 1 wherein the streams manager selects the at least one virtual machine according to cost, and specifies in the request to the cloud manager the at least one virtual machine.

4. The apparatus of claim 1 wherein the portion of the streaming application deployed to the at least one virtual machine comprises a single operator.

5. The apparatus of claim 1 wherein the portion of the streaming application deployed to the at least one virtual machine comprises a plurality of operators.

6. The apparatus of claim 1 wherein the streams manager determines when the cost of the streaming application can be reduced by comparing current cost of at least one portion of the streaming application to at least one cost threshold.

7. The apparatus of claim 1 wherein the cost of executing the streaming application includes cost of hosting virtual machines that execute the streaming application and further includes bandwidth cost for the virtual machines that execute the streaming application.

8. The apparatus of claim 7 wherein the cost of executing the streaming application includes cost of supporting the virtual machines that execute the streaming application and further includes at least one billing policy for the at least one virtual machine.

9. The apparatus of claim 8 wherein the cost of executing the streaming application includes historic usage, requirements and performance.

* * * * *