



US 20160300589A1

(19) **United States**

(12) **Patent Application Publication**

**Chen et al.**

(10) **Pub. No.: US 2016/0300589 A1**

(43) **Pub. Date: Oct. 13, 2016**

(54) **NEAR-FIELD TRANSDUCER WITH ENLARGED REGION, PEG REGION, AND HEAT SINK REGION**

(52) **U.S. Cl.**  
CPC ..... *G11B 5/3133* (2013.01); *G11B 5/4866* (2013.01); *G11B 5/6088* (2013.01); *G11B 5/314* (2013.01); *G11B 2005/0021* (2013.01)

(71) Applicant: **Seagate Technology LLC**, Cupertino, CA (US)

(72) Inventors: **Weibin Chen**, Bloomington, MN (US); **Chubing Peng**, Eden Prairie, MN (US); **Werner Scholz**, Camberwell (AU)

(21) Appl. No.: **15/183,065**

(22) Filed: **Jun. 15, 2016**

**Related U.S. Application Data**

(63) Continuation of application No. 13/961,638, filed on Aug. 7, 2013, now Pat. No. 9,384,770.

**Publication Classification**

(51) **Int. Cl.**  
*G11B 5/31* (2006.01)  
*G11B 5/60* (2006.01)  
*G11B 5/48* (2006.01)

(57) **ABSTRACT**

A near-field transducer includes an enlarged region having a top side adjacent to a magnetic pole, a base side opposite the top side, and a circumference that extends from proximal to a media-facing surface to distal to a media-facing surface. The near-field transducer includes a peg region in contact with a region of the base side of the enlarged region, the peg region extending from the enlarged region towards the media-facing surface. The near-field transducer also includes a heat sink region having a contact side, a base side, and a circumference that extends from proximal to the media-facing surface to distal from the media-facing surface. The contact side of the heat sink region is in thermal contact with both the peg region and at least a region of the base side of the enlarged region.

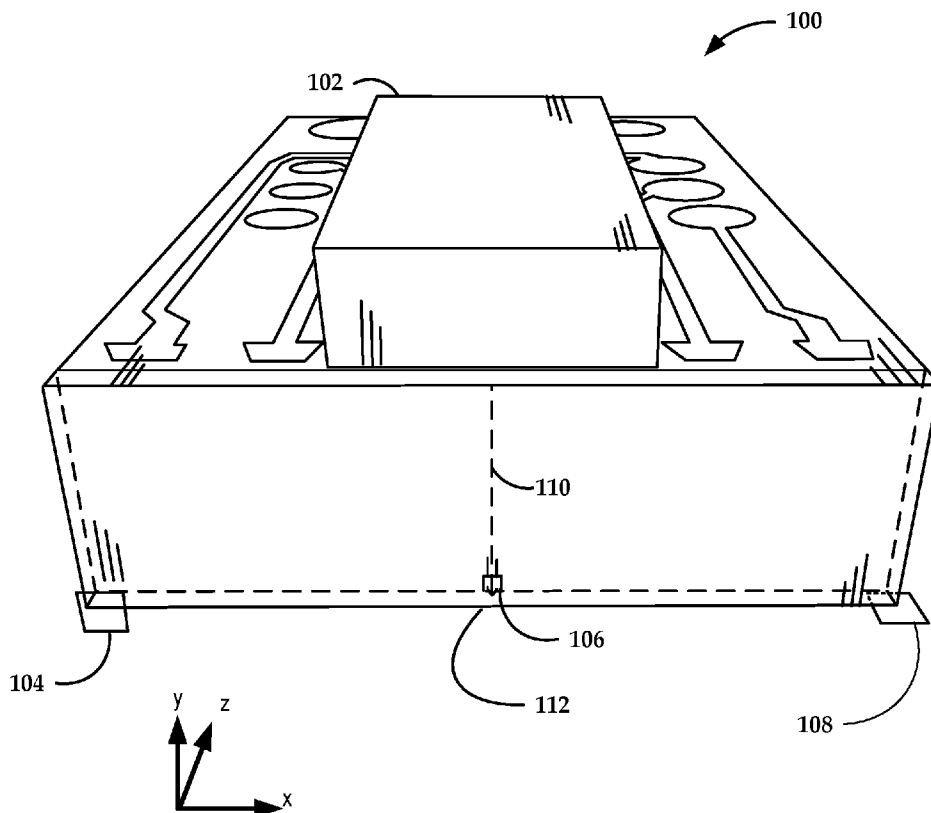

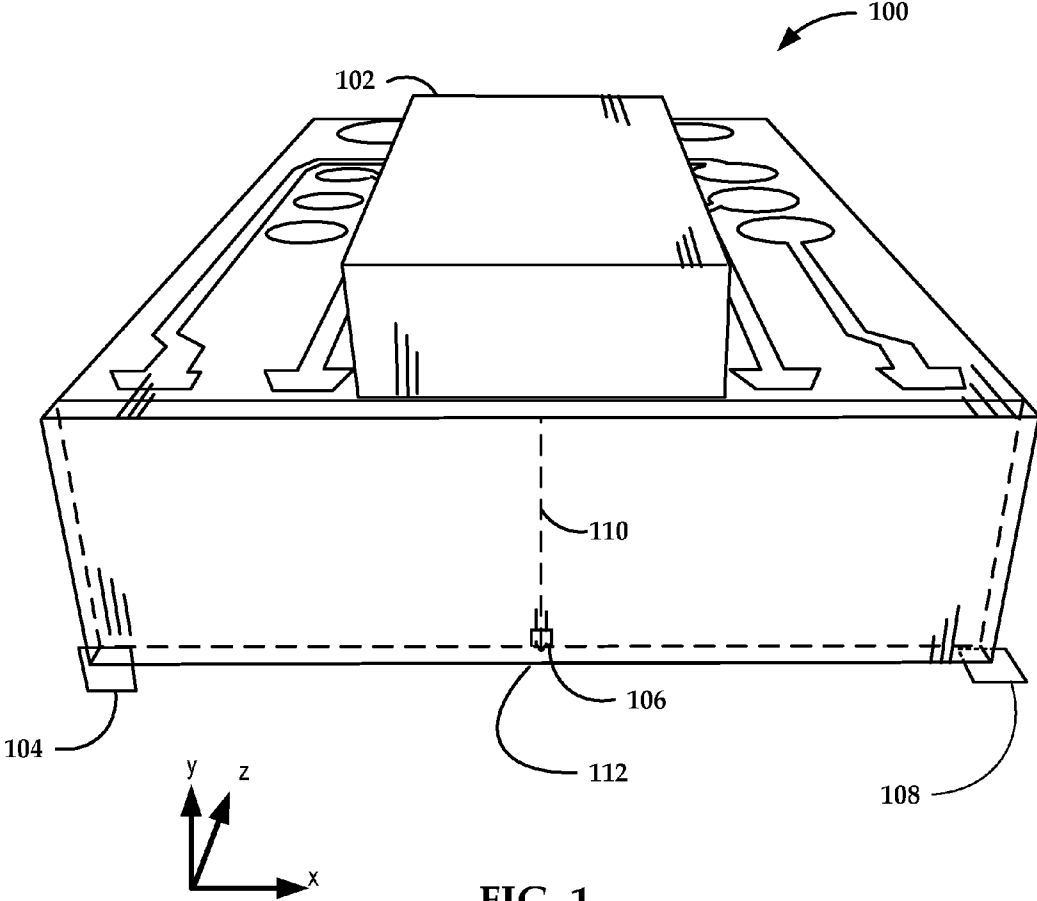

FIG. 1

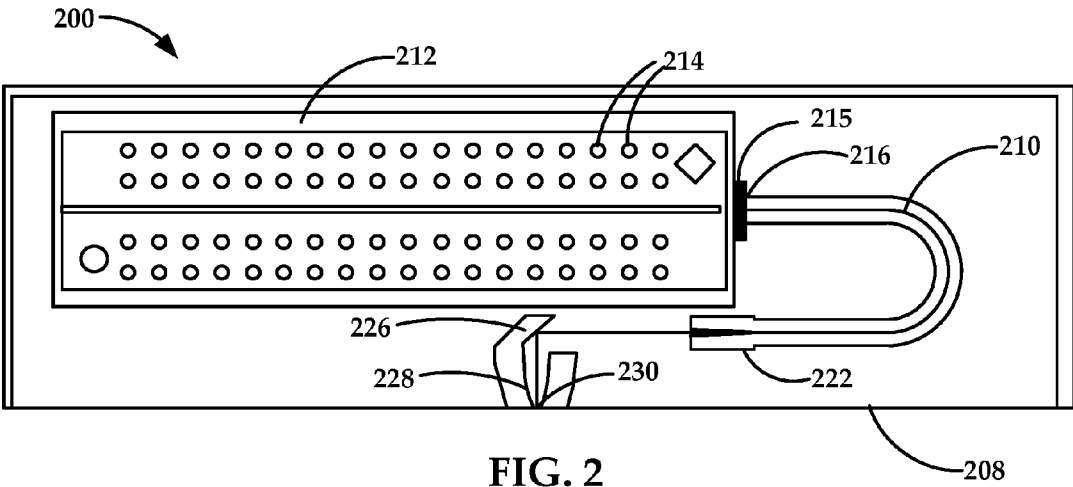

FIG. 2

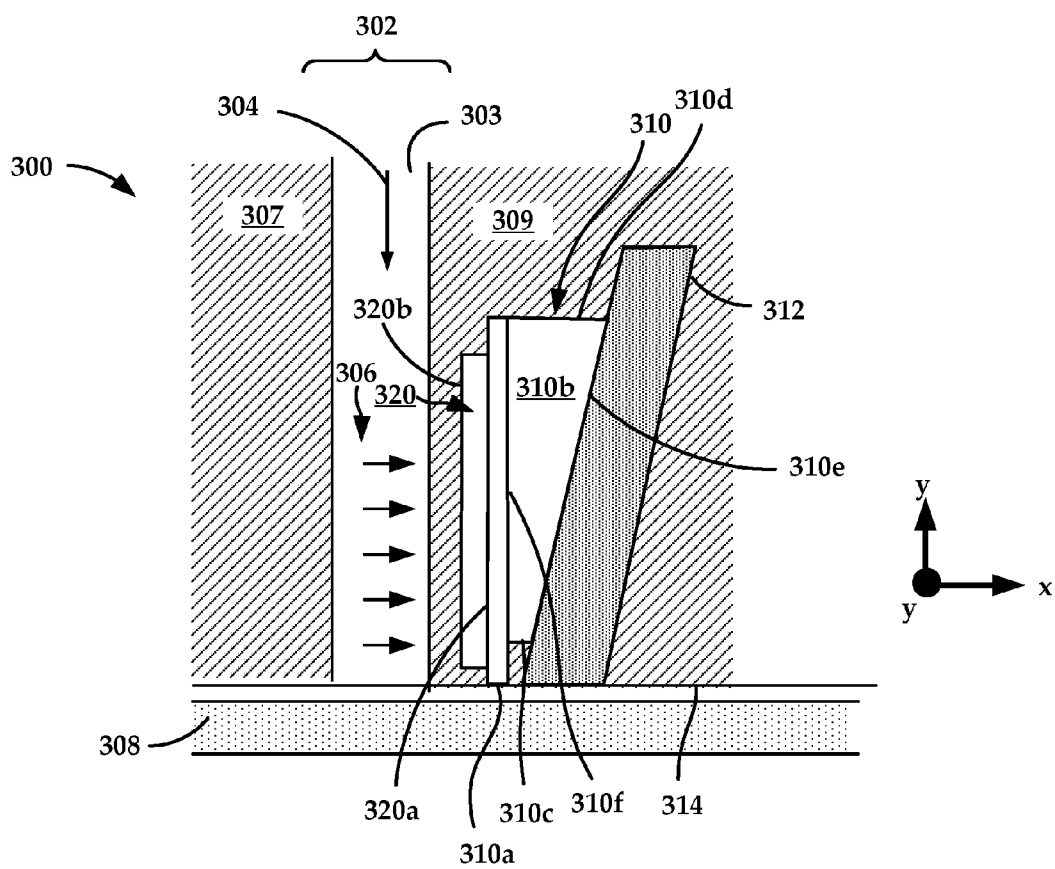

FIG. 3

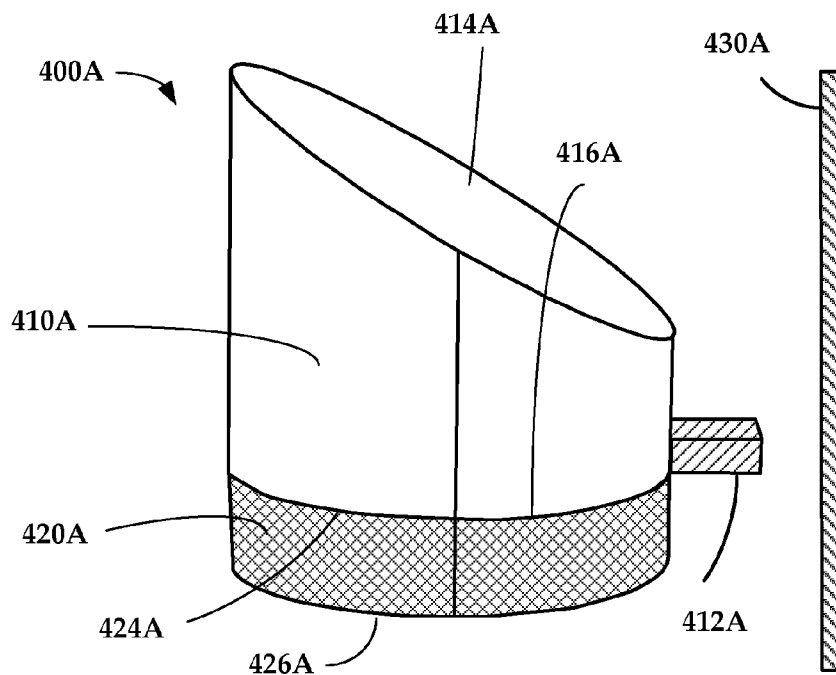

FIG. 4A

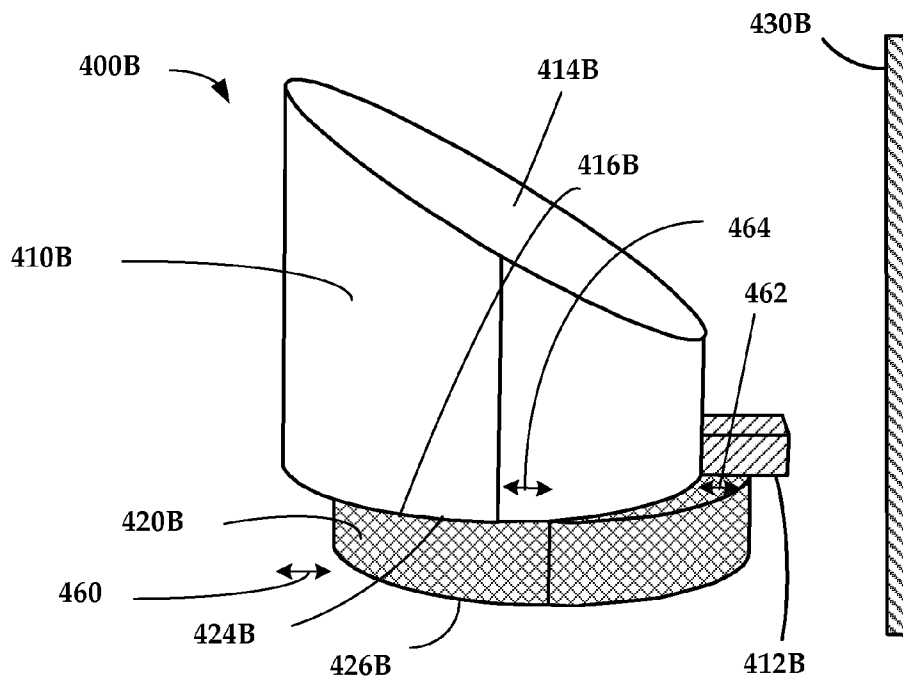

FIG. 4B

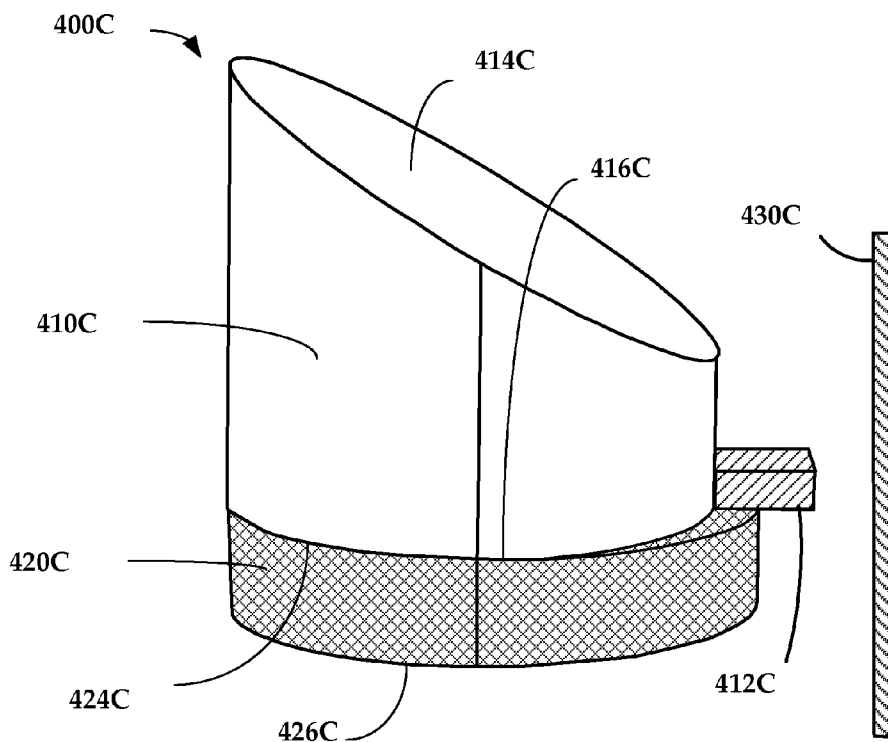

FIG. 4C

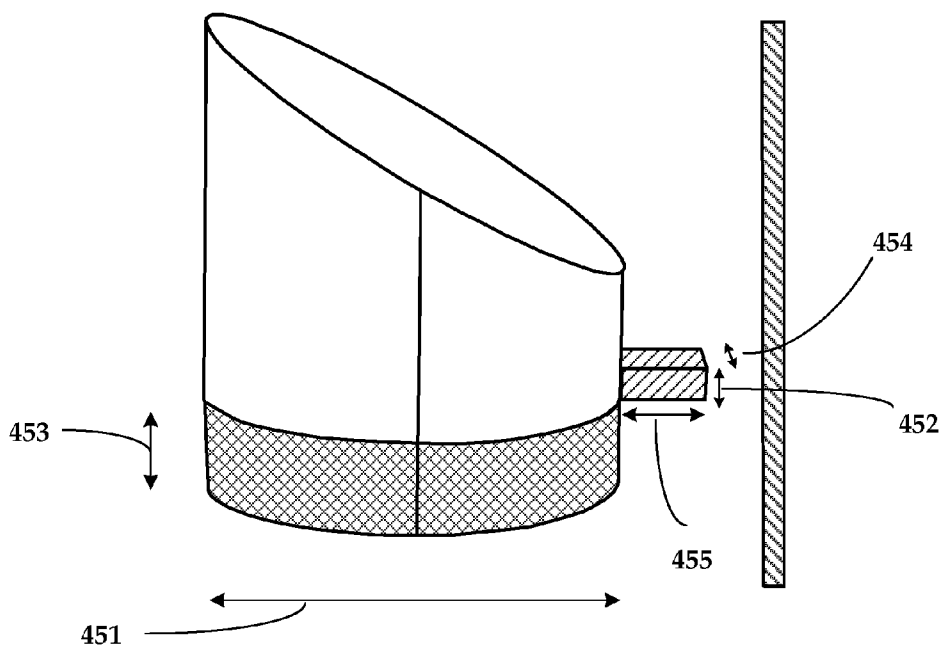

FIG. 4D

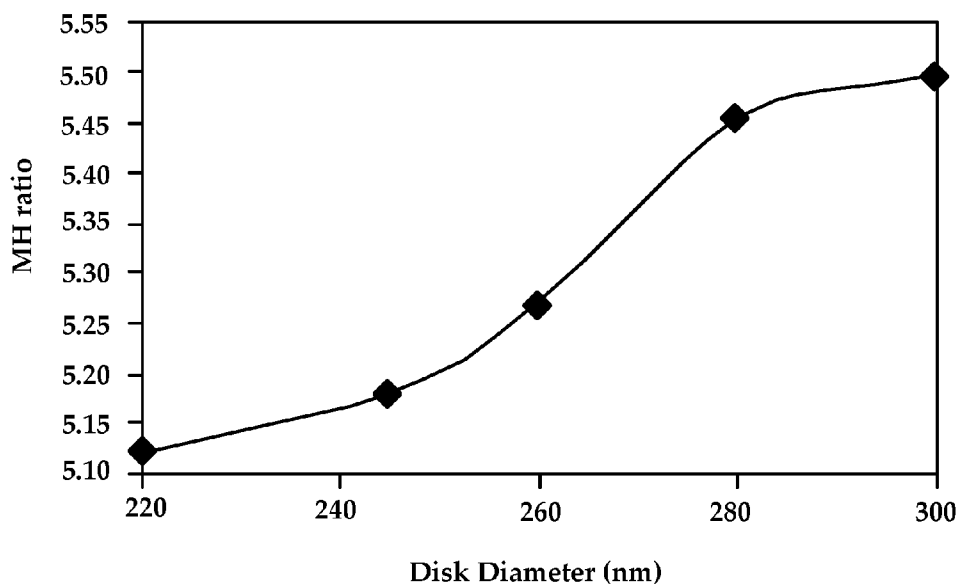

FIG. 5A

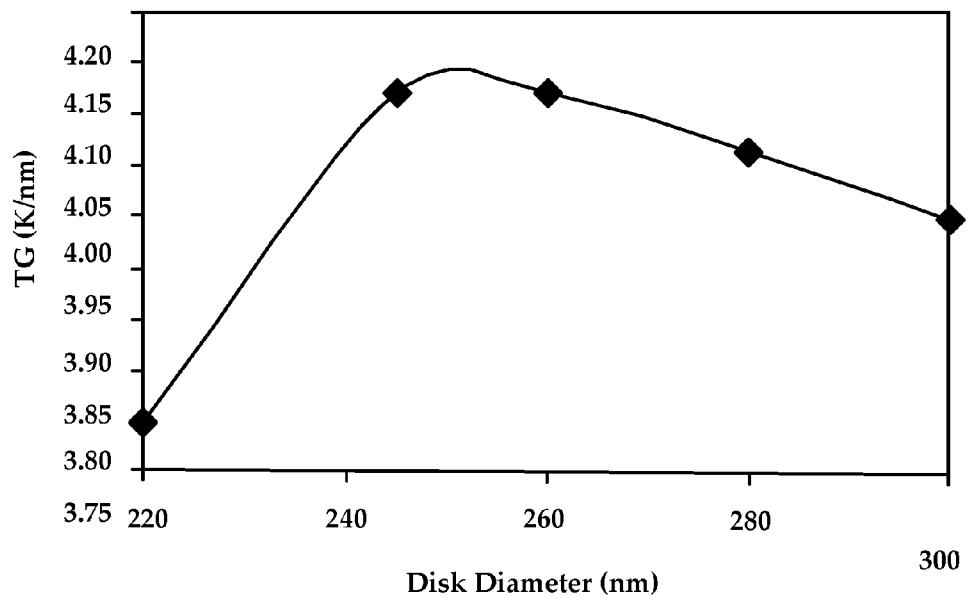

FIG. 5B

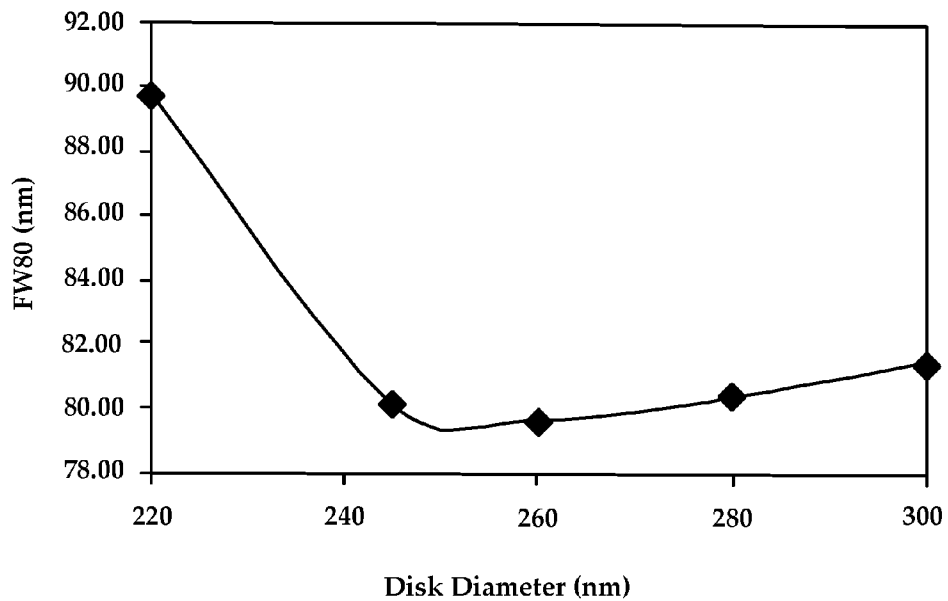

FIG. 5C

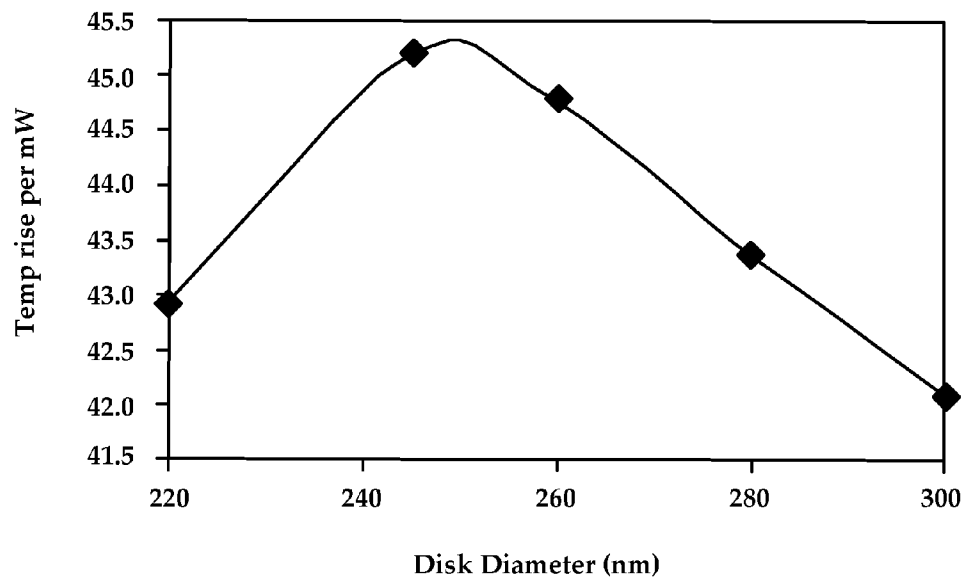

FIG. 5D



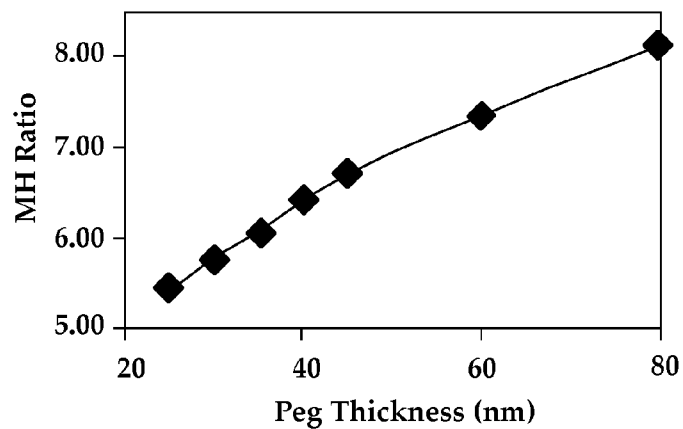

FIG. 6A

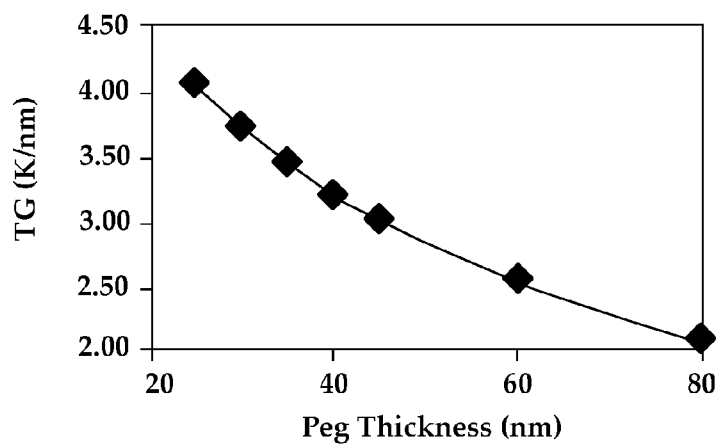

FIG. 6B

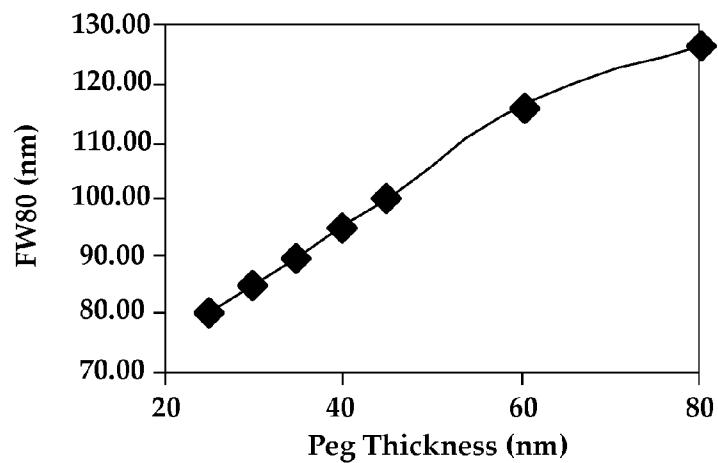

FIG. 6C

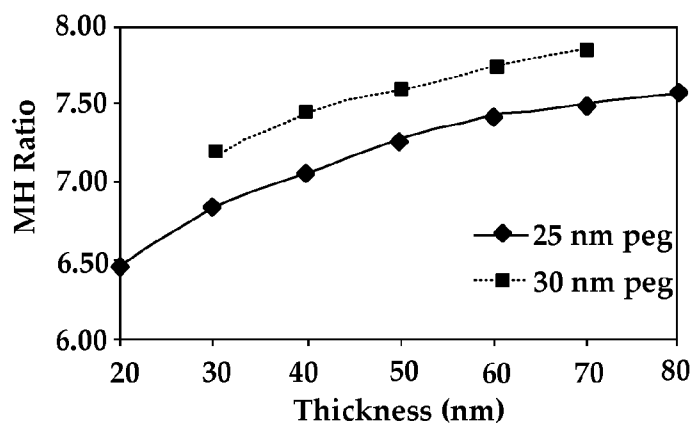

FIG. 7A

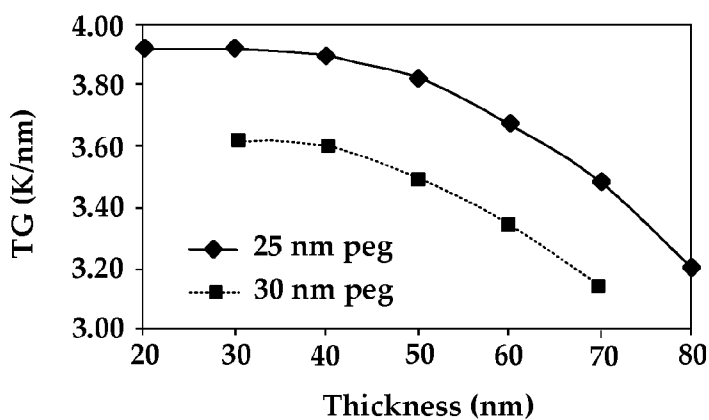

FIG. 7B

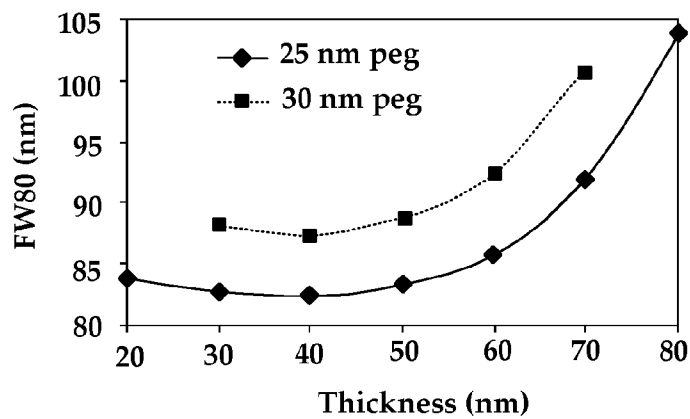

FIG. 7C

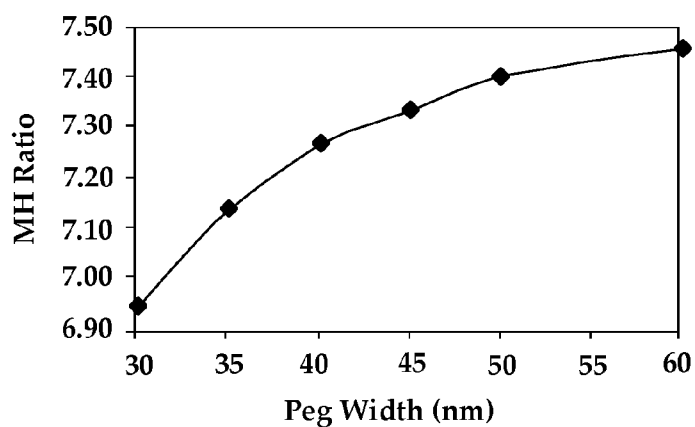

FIG. 8A

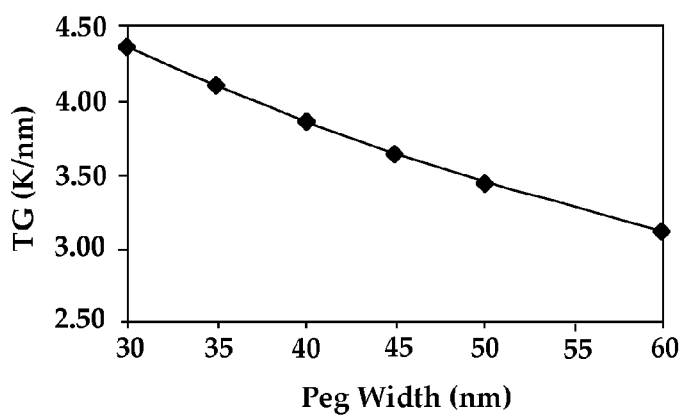

FIG. 8B

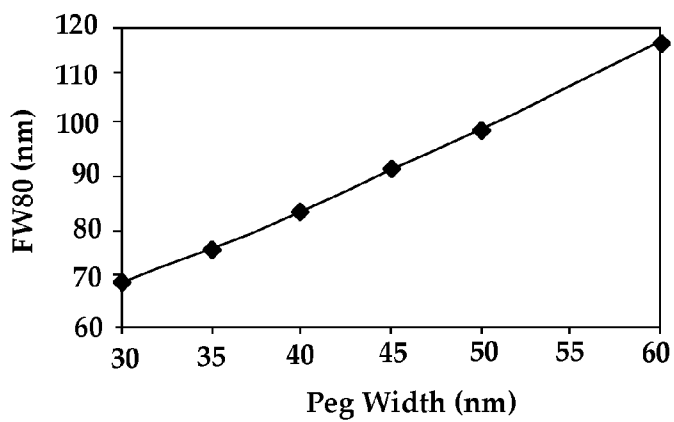

FIG. 8C

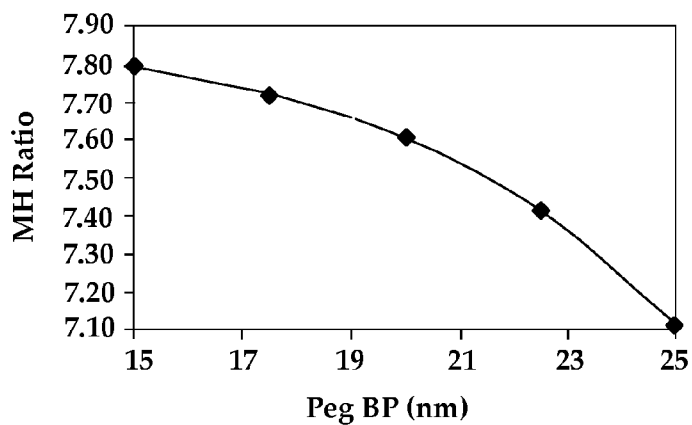

FIG. 9A

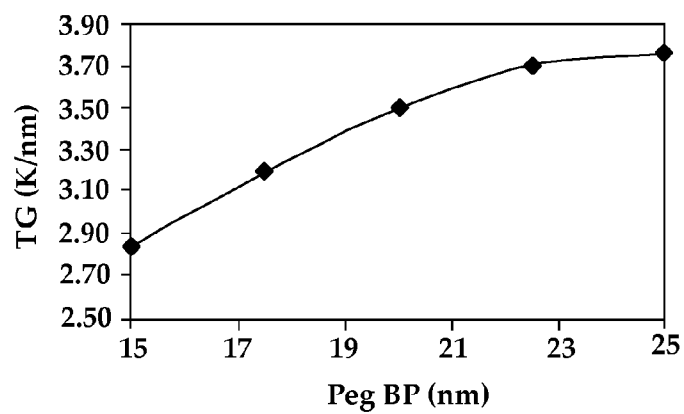

FIG. 9B

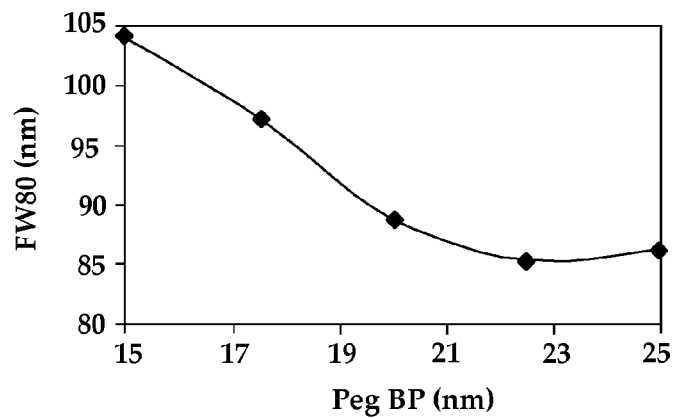

FIG. 9C

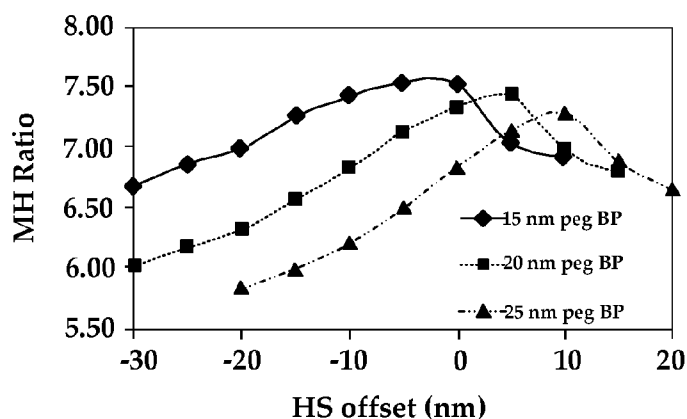

FIG. 10A

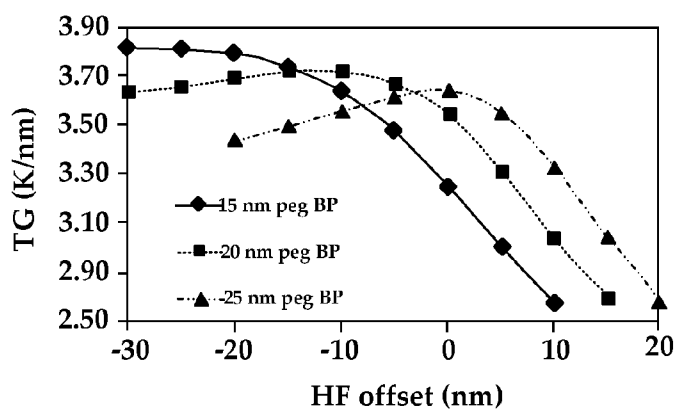

FIG. 10B

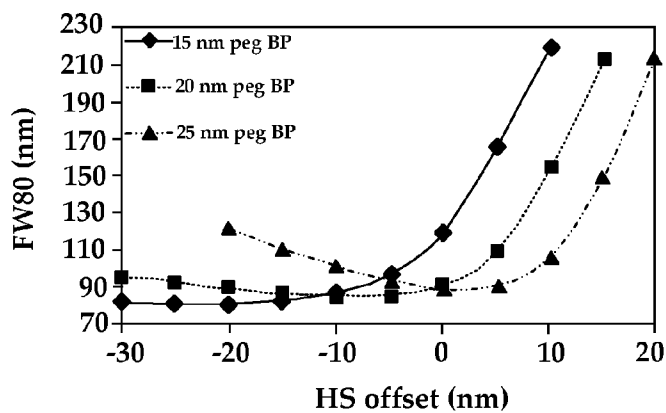

FIG. 10C

**NEAR-FIELD TRANSDUCER WITH ENLARGED REGION, PEG REGION, AND HEAT SINK REGION**

**CROSS REFERENCE TO RELATED CASES**

[0001] This is a continuation of U.S. patent application Ser. No. 13/961,638, filed Aug. 7, 2013, which is hereby incorporated by reference in its entirety.

**SUMMARY**

[0002] Embodiments are directed to a near-field transducer comprising an enlarged region having a top side adjacent to a magnetic pole, a base side opposite the top side, and a circumference that extends from proximal to a media-facing surface to distal from the media-facing surface. The near-field transducer also includes a peg region in contact with at least a portion of the base side of the enlarged region and extending from the enlarged region towards the media-facing surface and a heat sink having a contact side and a base side, and a circumference that extends from proximal to the media-facing to distal from the medial-facing surface. The contact side of the heat sink is in thermal contact with both the peg region and at least a portion of the base side of the enlarged region.

[0003] Embodiments are directed magnetic recording system comprising a hard drive slider that includes a near-field transducer. The near-field transducer comprises an enlarged region having a top side adjacent to a magnetic pole, a base side opposite the top side, and a circumference that extends from proximal to a media-facing surface to distal from the media-facing surface. A peg region is in contact with at least a region of the base side of the enlarged region and extends from the enlarged region towards the media-facing surface. A heat sink region has a contact side and a base side, and a circumference that extends from proximal to the media-facing to distal from the medial-facing surface. The contact side of the heat sink region is in thermal contact with both the peg region and at least a region of the base side of the enlarged region.

[0004] The above summary is not intended to describe each disclosed embodiment or every implementation of the present disclosure. The figures and the detailed description below more particularly exemplify illustrative embodiments

**BRIEF DESCRIPTION OF THE DRAWINGS**

[0005] Throughout the specification reference is made to the appended drawings, where like reference numerals designate like elements, and wherein:

[0006] FIG. 1 is a perspective view of a hard drive slider that includes a disclosed near-field transducer.

[0007] FIG. 2 is a more detailed front view of the hard drive slider shown in FIG. 1.

[0008] FIG. 3 is a side cross-sectional view of a provided near-field transducer and waveguide according to an example embodiment;

[0009] FIGS. 4A-4C are plan views of embodiments of provided near-field transducers.

[0010] FIG. 4D is a plan view of FIG. 4A with various modeled parameters identified.

[0011] FIGS. 5A-5D are graphs of media to head temperature (“MH”) ratio, thermal gradient (“TG”), full width at

80% maximum (“FW80”), and temperature rise vs. heat sink disk diameter (in nm) for an embodied provided near-field transducer.

[0012] FIGS. 6A-6C are graphs of MH ratio, TG, and FW80 ratio vs. peg thickness for an embodied provided near-field transducer.

[0013] FIGS. 7A-7C are graphs of MH ratio, TG, and FW80 vs. heat sink disk thickness (in nm) for an embodied provided near-field transducer.

[0014] FIGS. 8A-8C are graphs of MH ratio, TG, and FW80 vs. peg width for an embodied provided near-field transducer.

[0015] FIGS. 9A-9C are graphs of MH ratio, TG, and FW80 vs. peg break point length (in nm) for an embodied provided near-field transducer.

[0016] FIGS. 10A-10C are graphs of MET ratio, TG, and FW80 vs. HF offset as a function of various peg lengths (in nm) for an embodied provided near-field transducer.

[0017] The figures are not necessarily to scale. Like numbers used in the figures refer to like components. However, it will be understood that the use of a number to refer to a component in a given figure is not intended to limit the component in another figure labeled with the same number.

**DETAILED DESCRIPTION**

[0018] In the following description, reference is made to the accompanying set of drawings that form a part of the description hereof and in which are shown by way of illustration several specific embodiments. It is to be understood that other embodiments are contemplated and may be made without departing from the scope of the present disclosure. The following detailed description, therefore, is not to be taken in a limiting sense.

[0019] Unless otherwise indicated, all numbers expressing feature sizes, amounts, and physical properties used in the specification and claims are to be understood as being modified in all instances by the term “about.” Accordingly, unless indicated to the contrary, the numerical parameters set forth in the foregoing specification and attached claims are approximations that can vary depending upon the desired properties sought to be obtained by those skilled in the art utilizing the teachings disclosed herein. The use of numerical ranges by endpoints includes all numbers within that range (e.g. 1 to 5 includes 1, 1.5, 2, 2.75, 3, 3.80, 4, and 5) and any range within that range.

[0020] Various embodiments disclosed herein are generally directed to systems and apparatuses that facilitate coupling a laser diode to a magnetic writer that includes a magnetic write head. The systems and apparatuses include a plasmonic near-field transducer for heat-assisted magnetic recording (HAMR). Plasmonic near-field transducers can generate a large amount of heat in their writing tip. Disclosed are apparatuses and methods directed to managing heat buildup in the writing tip of plasmonic near-field transducers for heat-assisted magnetic recording.

[0021] The present disclosure is generally directed to read-write heads used in magnetic recording devices such as hard drives. In particular, this disclosure relates to heat-assisted magnetic recording (HAMR), which can be used to increase areal data density of magnetic media. In a HAMR device, information bits are recorded in a storage layer at elevated temperatures in a specially configured magnetic media. The use of heat can overcome superparamagnetic effects that might otherwise limit the areal data density of the

media. As such, HAMR devices may include magnetic write heads for delivering electromagnetic energy to heat a small confined media area (spot size) at the same time the magnetic write head applies a magnetic field to the media for recording.

**[0022]** One way to achieve a tiny confined hot spot is to use an optical near-field transducer (NFT), such as a plasmonic optical antenna or an aperture, located near an air-bearing surface of a hard drive slider. Light may be launched from a light source (e.g., a laser diode) into optics integrated into a slider. An example of such integrated optics includes a waveguide formed from core and cladding layers with high contrast between respective refractive indices. Light propagating in the waveguide may be directed to an optical focusing element, such as a planar solid immersion mirror (PSIM). The PSIM may concentrate the energy into a NFT. The NFT causes the energy to be delivered to the media in a very small spot.

**[0023]** A waveguide, NFT, and PSIM are examples of integrated optical devices that are formed within the slider. The field of integrated optics generally relates to the construction of optics devices on substrates, sometimes in combination with electronic components, to produce functional systems or subsystems. For example, light may be transferred between components via waveguides that are built up on a substrate using layer deposition techniques. These waveguides may be formed as a layer of materials, with a middle core layer having a relatively high refractive index, and top/bottom cladding layers of relatively low refractive index. Other optical components may be formed in similar fashion, including the NFT and PSIM discussed above.

**[0024]** In a HAMR slider, light is launched into these integrated optics components from a light source such as a laser diode. One way to launch light into a slider is from an externally mounted laser via an optical waveguide or grating coupler fabricated in a slider. Another way is to place a laser light source, such as a laser diode, into the slider, called laser-in-slider (LiS) light delivery. In laser-in-slider configurations, light is launched from the emitting facet of a laser diode into an optical waveguide. Laser-in-slider light delivery can be integrated at a wafer level and may be suitable for mass production.

**[0025]** FIG. 1 is a perspective view of a hard drive slider that includes a disclosed plasmonic near-field transducer (NFT). HAMR slider 100 includes laser diode 102 located on top of HAMR slider 100 proximate to trailing edge surface 104 of HAMR slider 100. Laser diode 102 delivers light proximate to read/write head 106, which has one edge on air-bearing surface (also referred to as “media-facing surface”) 108 of HAMR slider 100. Air-bearing surface 108 is held proximate to a moving media surface (not shown) during device operation.

**[0026]** Laser diode 102 provides electromagnetic energy to heat the media at a point near to read/write head 106. Optical coupling components, such as a waveguide 110, are formed integrally within HAMR slider 100 to deliver light from laser diode 102 to the media. In particular, local waveguide 110 and NFT 112 may be located proximate read/write head 106 to provide local heating of the media during write operations. Laser diode 102 in this example may be an integral, edge-emitting device, although it will be appreciated that waveguide 110 and NFT 112 may be used

with any light source and light delivery mechanisms. For example, a surface emitting laser (SEL) may be used instead of an edge firing laser.

**[0027]** While the example in FIG. 1 shows laser diode 102 integrated with HAMR slider 100, NFT 112 discussed herein may be useful in any type of light delivery configuration. For example, in a free-space light delivery configuration, a laser may be mounted externally to the slider, and coupled to the slider by way of optic fibers and/or waveguides. The slider in such an arrangement may include a grating coupler into which light is coupled and delivered to slider-integrated waveguide 110 which energizes NFT 112.

**[0028]** A HAMR device utilizes the types of optical devices described above to heat a magnetic recording media (e.g., hard disc) in order to overcome superparamagnetic effects that limit the areal data density of typical magnetic media. When writing to a HAMR medium, the light can be concentrated into a small hotspot over the track where writing takes place. The light propagates through waveguide 110 where it is coupled to NFT 112 either directly from the waveguide or by way of a focusing element. Other optical elements, such as couplers, mirrors, prisms, etc., may also be formed integral to the slider. The optical elements used in HAMR recording heads are generally referred to as integrated optics devices.

**[0029]** As a result of what is known as the diffraction limit, optical components cannot be used to focus light to a dimension that is less than about half the wavelength of the light. The lasers used in some HAMR designs produce light with wavelengths on the order of 700-1550 nm, yet the desired hot spot is on the order of 50 nm or less. Thus the desired hot spot size is well below half the wavelength of the light. Optical focusers cannot be used to obtain the desired hot spot size, being diffraction limited at this scale. As a result, NFT 112 is employed to create a hotspot on the media.

**[0030]** NFT 112 is a near-field optics device designed to reach local surface plasmon resonance at a designed wavelength. A waveguide and/or other optical element concentrates light on a transducer region (e.g., focal point) where NFT 112 is located. NFT 112 is designed to achieve surface plasmon resonance in response to this concentration of light. At resonance, a high electric field surrounds NFT 112 due to the collective oscillations of electrons at the metal surface. Part of this field will tunnel into a storage medium and get absorbed, thereby raising the temperature of a spot on the media as it being recorded. NFTs generally have a surface that is made of a material that supports surface plasmons (“plasmonic metal”) such as aluminum, gold, silver, copper, or alloys thereof. They may also have other materials but they must have a material that supports surface plasmons on their outer surface.

**[0031]** FIG. 2 is a front view of a disclosed apparatus showing electrical and optical interface features of slider assembly 200 that mates with an edge-emitting laser diode (e.g., laser diode 102 in FIG. 1). Cavity 212, solder bumps 214, waveguide input 216, waveguide 210, and air-bearing surface 208 seen here, were previously illustrated in FIG. 1. Solder bumps 214 on slider assembly 200 are configured to interface with the plurality of solder pads on the lower surface of a laser diode. The laser diode may include an output facet on one end that launches light into waveguide input 216 of waveguide 210 for delivery to the recording media. Integrated optics associated with light delivery may

include coupling elements, beam expanders **222**, collimators, focusing elements **226**, such as PSIM, concentrating elements, **228** such as a plasmonic near-field transducer focused adjacent to focal point **230**. Furthermore, located at the edge of cavity **212** between the laser diode and waveguide input **216** is gap **215**. The size of gap **215** may depend on the alignment of the laser diode to cavity **212**, but a typical size may be from about 0.25-1.0  $\mu\text{m}$  and up to about 10  $\mu\text{m}$ . Gap **215** may also have an aspect ratio of about 5 to 6. The aspect ratio is the ratio between depth of cavity **212** and the width of cavity **212**.

**[0032]** NFTs that include an enlarged region and a peg region have been disclosed. In the context of describing an NFT, the term “region” is used interchangeably with “portion” and refers to a bounded three-dimensional feature in which the boundaries may either be physical boundaries or may be arbitrarily chosen for exemplary reasons. These NFTs can include a disk-shaped enlarged region that can be made of a plasmonic metal and is configured to receive light from a laser diode. The peg region is in optical and/or electrical communication with the disk-shaped enlarged region and I creates a focal point for the energy received by the enlarged region. In the context of describing an NFT, the term “disk” refers to three-dimensional shapes that include a cylinder, a base side, and a top side that may or may not be in a plane parallel with the base side.

**[0033]** Temperature increase inside the peg region of NFTs is a challenge in HAMR write heads. It would be desirable to design an NFT that has less of a temperature increase than NFTs known in the art. To reduce the temperature of the peg region of an NFT the thermal resistance of the peg should be reduced. However, the thermal resistance of the peg must also be reduced without substantially compromising the transducer performance (i.e. coupling efficiency). The coupling efficiency is the percentage of energy absorbed into the media surface, divided by the energy input at the incident plane of the PSIM from the energy source.

**[0034]** Also, related to the temperature increase is the thermal resistance. Thermal resistance of an object is directly proportional to the length of the object and inversely proportional to the cross-sectional area and thermal conductivity of the object (Fourier’s Law). A typical material for constructing an NFT is gold, which has good mechanical and optical/plasmonic properties compared to other materials. Varying the NFT material may not substantially increase the thermal conductivity. Therefore, other means are required for reducing the thermal resistance of the peg region. In one aspect, to minimize thermal resistance the length of the peg region may be decreased. In another aspect, to minimize thermal resistance the cross-sectional area of the peg may also be increased. However, the cross-sectional area of the peg at the air-bearing surface, nearest the recording media, is dictated by the parameters required for magnetic recording. Additionally, specific wavelength of light from the laser diode dictates the size of the enlarged region of the NFT and the peg length in order to get optimal (maximum) coupling efficiency of the laser light to the NFT.

**[0035]** The present disclosure relates to systems and apparatuses that include plasmonic near-field transducers. FIG. 3 is a side cross-sectional view of an exemplary provided near-field transducer and waveguide according to an example embodiment that illustrates features disclosed herein. In reference now to FIG. 3, a cross-sectional view

shows details of an NFT **310** and waveguide **302** of a HAMR apparatus **300** according to an example embodiment. The NFT **310**, waveguide **302**, and other components are built on a substrate plane, which is parallel to the xy-plane in this view. NFT **310** is located proximate a media-facing surface **314** (e.g., ABS), which is held near a recording medium **308** during device operation, e.g., magnetic disk. In the orientation of FIG. 3, the media-facing surface **314** is arranged parallel to the x-y plane. Elongated waveguide core **303** may be disposed proximate the NFT **310**, NFT **310** being located at or near the media-facing surface **314**.

**[0036]** Waveguide core **303** is shown configured as a planar waveguide, and is surrounded by cladding layers **307** and **309** that have different indices of refraction than core **303**. Other waveguide configurations may be used instead of a planar waveguide, e.g., channel waveguide. Light **304** propagates through the waveguide core **303** along the negative y-direction. Electrical field lines **306** emanate from the waveguide core **303** and excite NFT **310**. NFT **310** delivers surface plasmon-enhanced, near-field electromagnetic energy along the negative y-direction where it exits at the media-facing surface **314**. This may result in a highly localized hot spot (not shown) on media **308**. Further illustrated in FIG. 3 is magnetic recording pole **312** that is located alongside NFT **310**. Magnetic pole **312** generates a magnetic field (e.g., perpendicular field) used in changing the magnetic orientation of the hotspot during writing.

**[0037]** NFT **310** includes enlarged region **310b** of plasmonic material (e.g., gold, silver, copper, and combinations or alloys thereof). Enlarged region **310b** has top side **310e** adjacent to magnetic pole **312**, base side **310f** opposite top side **310e**, and a circumference that extends from proximal **310c** to media-facing surface **314** to distal the media-facing surface **310d** (for example, along the y-axis). The NFT **310** further includes peg region **310a** of plasmonic material that is in contact with at least a portion of base side **310f** of enlarged region. Peg region **310a** extends from enlarged region **310b** towards media-facing surface **314**. As will be described in greater detail below, the projection of enlarged region **310b** onto the xy-plane is narrowed at the output end.

**[0038]** NFT **310** also includes heat sink **320**. Heat sink **320** has contact side **320a**, base side **320b** and a circumference that extends from proximal media-facing surface **314** to distal from media-facing surface **314** in a manner analogous to that of enlarged region **310b**. Contact side **320a** of heat sink **320** is in thermal contact with both peg region **310a** and at least a portion of base side **310f** of enlarged region **310**. FIG. 3 shows a line between enlarged region **310b** and peg region **310a**. This line is for illustrative purposes only. Commonly, enlarged region **310b** and enlarged region **310a** are one piece and make up NFT **310**. Thus, peg region **310a** may extend from part of the circumference of NFT **310** as will be illustrated later.

**[0039]** NFT **310** is excited by a waveguide mode of the planar waveguide **302**, polarized with dominant electric field **306** normal to the plasmonic metal surfaces of the NFT **310**, e.g. circumference of enlarged region **310b**. Enlarged region **310b** also includes top side **310e** that faces, and in this example directly contacts, magnetic pole **312**. Enlarged region **310b** of NFT **310** is shaped to condense the field and the peg **310a** is designed to resonate such that the NFT



efficiency is enhanced on one hand, and on the other hand scattering of the field is reduced along the circumference of the enlarged region **310b**.

**[0040]** Excitation of NFT **310** may occur over a large region of enlarged region **310b** and heat sink region **320**, however, there is no limitation as to where or how NFT **310** may be excited by energy delivered by the waveguide **302**. Generally, it will be understood that NFT **310** is designed to direct the surface plasmons from the output end of peg region **310a** to media **308** when media **308** is proximate to the media-facing surface **314**. The end peg region **310a** protrudes out from elongated region **310b** near media-facing surface **314**. This protrusion can improve NFT efficiency and thermal gradient for writing sharp magnetic transitions. Surface plasmon waves are generated mainly at surfaces of peg region **310a** and enlarged region **310b** nearest planar waveguide core **303**. The tip of the peg region may have different cross-section and or size from the body of the peg region.

**[0041]** The waveguide mode is  $TE_{00}$ , which is fundamental and transverse-electric polarized. The dominant electric field **306** is along x-direction and normal to base side **310f** of enlarged region **310**. The mode index of dielectric waveguide **302** is close to that of the surface-plasmon waves, therefore surface-plasmon waves are efficiently excited on enlarged region **310b** and heat-sink region **320**. The elongated peg **310a** functions as a monopole antenna. At resonance, it interacts with the dielectric waveguide mode as well as the surface-plasmon waves generated on the circumferences of enlarged region **310b** and heat sink region **320**, which pulls the field toward itself and delivers the optical energy into the recording media **308**. The presence of heat sink **320** helps to increase the coupling efficiency and to reduce the temperature of the writing tip of peg region **310a**.

**[0042]** FIGS. 4A-4C are plan views of various embodiments of provided NFTs. FIG. 4A is an illustration of one embodiment, **400A**. NFT **400A** includes enlarged region **410A** that has top side **414A** adjacent to a magnetic pole (not shown) and base side **424A** opposite (but not necessarily parallel to) top side **414A**. Enlarged region has a circumference that extends from proximal media-facing surface **430A** to distal media-facing surface **430A**. In the embodiment illustrated in FIG. 4A, the circumference is cylindrical, having a cross-section parallel to the base side of the enlarged region that is circular, however other shapes of enlarged region are also contemplated. In some embodiments, the circumference can be conical. In some embodiments, the circumference of the enlarged region may be elliptical.

**[0043]** When the circumference of the enlarged region has circular or elliptical cross-section, the enlarged region can be sometimes referred to as a disk. In some embodiments, a plane that includes the top side of the enlarged region can be at an angle with respect to a plane that includes the base side of the enlarged region. In some other embodiments, the circumference of the enlarged region may be the sides of a regular or irregular rectangular or triangular parallelepiped having a cross-section that is a square, rectangle, triangle, regular or irregular polygon. In some embodiments, the area of the top side of the enlarged region is substantially the same as the area of the base side of the enlarged region. More complex geometrical shapes of the enlarged region can also be within the scope of this disclosure.

**[0044]** NFT **400A** also has peg region **412A** that is in contact with at least a portion of base side **424A** of enlarged region **410A** and extends from enlarged region **410A** towards media-facing surface **430A**. As shown in FIG. 3, peg region **412A** is an extension of enlarged region **410A**. FIG. 4A shows the end of peg region **412A** (the region closest to media-facing surface **430A**) as having a non-tapered end. However, the end may be tapered to provide a smaller surface area at the tip of the peg region to better focus the energy from the NFT onto a small spot on the media.

**[0045]** NFT **400A** includes heat sink **420A** that has contact side **424A** and base side **426A**. Heat sink **420A** also has a circumference that extends from proximal media-facing surface **430A** to distal media-facing surface **430A**. Contact side **424A** of heat sink **420A** is in thermal contact with both peg region **412A** and at least a portion of base side **424A** of enlarged region **410A**. When the circumference of the heat sink region is circular or elliptical, the heat sink region can be sometimes referred to as a disk. In some embodiments, the area of the contact side of the heat sink region is the same as the area of the base side of the heat sink region.

**[0046]** FIG. 4B is an illustration of another embodiment of a provided NFT. NFT **400B** includes enlarged region **410B** that has top side **414B** adjacent to a magnetic pole (not shown) and base side **424B** opposite (but not necessarily parallel to) top side **414B**. Enlarged region **410B** has a circumference that extends from proximal media-facing surface **430B** to distal media-facing surface **430B**. NFT **400B** also has peg region **412B** that is in contact with at least a region of base side **424B** of enlarged region **410B** and extends from enlarged region **410B** towards media-facing surface **430B**. NFT **400B** includes heat sink **420B** that has contact side **424B** and base side **426B**. Heat sink **420B** also has a circumference that extends from proximal media-facing surface **430B** to distal media-facing surface **430B**. Contact side **424B** of heat sink **420B** is in thermal contact with both peg region **412B** and at least a portion of base side **424B** of enlarged region **410B**. The circumference of enlarged region **410B** proximal to media-facing surface **430B** is offset in a direction away from media-facing surface **430B** with respect to heat sink **420B** as shown in FIG. 4B. Also the circumference of enlarged region **410B** distal to media-facing surface **430B** is offset away from media-facing surface **430B** with respect to heat sink **420B**.

**[0047]** FIG. 4C is an illustration of another embodiment of a provided NFT. NFT **400C** includes enlarged region **410C** that has top side **414C** adjacent to a magnetic pole (not shown) and base side **424C** opposite (but not necessarily parallel to) top side **414C**. Enlarged region has a circumference that extends from proximal media-facing surface **430C** to distal media-facing surface **430C**. NFT **400C** also has peg region **412C** that is in contact with at least a region of base side **424C** of enlarged region **410C** and extends from enlarged region **410C** towards media-facing surface **430C**. NFT **400C** includes heat sink **420C** that has contact side **424C** and base side **426C**. Heat sink **420C** also has a circumference that extends from proximal media-facing surface **430C** to distal media-facing surface **430C**. Contact side **424C** of heat sink **420C** is in thermal contact with both peg region **412C** and at least a portion of base side **424C** of enlarged region **410C**. The circumference of enlarged region **410C** proximal to media-facing surface **430C** is offset in a direction away from media-facing surface **430C** with respect

to heat sink 420C as shown in FIG. 4C. The circumference of enlarged region 410C distal to media-facing surface 430C is not offset from media-facing surface 430C with respect to the circumference of the heat sink region 420C proximal to media-facing surface 430C.

[0048] The enlarged region and the peg region of disclosed near-field transducers can comprise a substrate which has been at least partially covered with a thin layer of plasmonic material. The substrate can comprise any material capable of supporting a thin layer of plasmonic material. Typical substrates include silicon wafers, inorganic and organic dielectrics, polymer dielectrics, glass, non-conductive metals and ceramics. Typical plasmonic materials include at least one of aluminum, silver, copper, gold, and alloys thereof. Gold is a typically used material due to its good mechanical properties, coupling efficiency and its ability to generate surface plasmons. The heat sink region can include materials that have a high heat conductivity. Materials useful for the heat sink region include gold, silver, or alloys thereof.

[0049] During the operation of the plasmonic near-field transducer, the plasmonic near-field transducer experiences a temperature rise. Modeling (finite element analysis of heat flow) has shown that the temperature rise is highest in the peg region of the near-field transducer. The models indicate that the electromagnetic field generated within the near-field transducer during the recording operation is highest within the peg region. Models show that the amplitude of the electromagnetic field is directly proportional to the energy absorption level. The disclosed plasmonic near-field transducers may include a heat sink region for cooling the NFT through improved heat dissipation from the peg region to the heat sink region.

[0050] Finite element analysis of various near-field transducer configurations was performed to identify the most important structural features of the near-field transducers that provide for improved (e.g., maximum) performance efficiency in HAMR recording heads. The responses of interest were recording media to recording head temperature ratio ("MH" ratio), thermal gradient ("TG"), and full width at 80% maximum thermal spot size ("FW80") in the media heated with the modeled transducers. Based upon modeling, it was determined that NFTs with a combination of higher MH ratio, and lower TG and FW80, provide for improved performance efficiency. The models were based upon designs of provided near-field transducers made in SiO<sub>2</sub>. The modeled NFTs had circular cross-sections and were generally for the structure of NFT illustrated in FIG. 4A. For the different models with results disclosed herein, the variables were heat sink disk diameter in nm (451 in FIG. 4D), peg thickness in nm (452 in FIG. 4D), thickness of heat sink with various peg thicknesses (453 in FIG. 4D), peg width in nm (454 in FIG. 4D) and peg length from the break point in nm (455 in FIG. 4D). In the modeled NFT, the disk diameter was 280 nm, the peg height was 20 nm, the peg thickness was 25 nm, and the closest distance of the sunken region to the waveguide core was 25 nm. In this disclosure, the term "break point" refers to the location in a peg region of a near-field transducer that is on the circumference of the enlarged region of a near-field transducer nearest to an air-bearing surface.

[0051] FIGS. 5A-5C show the modeled effect of heat sink disk diameter on MH ratio, TG, and FW80 for a silica NFT as illustrated in FIG. 4A. FIG. 5D illustrate the relationship

of heat sink disk diameter to temperature rise per mW of input laser power. To maximize MH, temperature rise per mW input laser power, and to minimize FW80, it can be seen that a disk diameter of from about 150 nm to about 350 nm, from about 240 nm to about 260 nm, or about 250 nm gives the best combination of desired properties.

[0052] FIGS. 6A-6C show the modeled effect of peg thickness on MH ratio, TG, and FW80 for a silica NFT as illustrated in FIG. 4A. In order to maximize MH ratio and TG and to minimize FW80, the best peg thickness is from about 25 nm to about 40 nm or about 35 nm.

[0053] FIGS. 7A-7C show the modeled effect of heat sink disk thickness on MH ratio, TG, and FW80 for two different peg thicknesses (25 nm and 30 nm). The 30 nm thick peg is seen to have a higher MH ratio but lower TG for all thicknesses of heat sink disks. A thicker peg gives a larger thermal spot (FW80). In order to maximize MH ratio and TG and to minimize FW80, a heat sink disk thickness of from about 10 nm to about 80 nm, from about 30 nm to about 60 nm, from about 35 nm to about 40 nm, or about 35 nm is desired along with a peg thickness of from about 25 nm to about 30 nm.

[0054] FIGS. 8A-8C show the modeled effect of peg width on MH ratio, TG, and FW80. To maximize MH ratio and TG, and minimize FW80, a peg width of from about 35 nm to about 40 nm or about 35 nm has the best combination of properties.

[0055] FIGS. 9A-9C show the modeled effect of peg length from the break point ("Peg BP") on MH ratio, TG, and FW80. Here the MH ratio is highest at a lower peg length from the break point, but the TG and FW80 increase with higher peg length from the break point. The peg region can extend from about 10 nm to about 30 nm from the break point on the enlarged region of the NFT.

[0056] NFT configurations that have an offset (shown as 464 in FIG. 4B) of the center of the enlarged region with respect to the center of the heat sink disk as shown in FIG. 4B were modeled as a function of three different peg lengths from the break point ("peg BP")—15 nm, 20 nm, and 25 nm. An offset of 0 indicates that the heat sink region lines up with the enlarged region as shown in FIG. 4A. A positive offset indicates the enlarged region of the NFT is offset towards the media-facing surface. A negative offset indicates the enlarged region of the NFT is offset away from the media-facing surface. The heat sink disk diameter was 280 nm, the heat sink disk thickness was 50 nm, the peg thickness was 25 nm, and the peg width was 45 nm. The overmill (shown as 462 in FIG. 4B) was 6 nm. The modeling results show a 15 nm peg length to break point with a -20 nm heat sink offset gives the best reliability of performance.

[0057] The effect of overhang of the enlarged region of the NFT compared to the heat sink region (460 in FIG. 4B) was modeled using an NFT with a structure as shown in FIG. 4B with a various heat sink disk diameters, a heat sink thickness of 50 nm, a peg thickness of 25 nm, a peg width of 45 nm, a peg length from the break point of 15 nm, an offset of -15 nm, with an overmill of 6 nm, and various overhangs in which the distal circumference of the enlarged region of the NFT overhangs the distal circumference of the heat sink region of the NFT (see 460 in FIG. 4B). Table 1 shows the modeled MH ratio, TG, and FW80 as a function of heat sink diameter and subsequently overhang.

TABLE 1

Modeled MH ratio, TG, and FW80 Changes as Function of Overhang				
HS Diameter (nm)	Overhang (nm)	MH ratio	TG	FW80
265	0	-3.45%	+1.37%	-1.94%
280	15	0	0	0
310	45	+2.74%	-3.20%	-3.22%

The data in Table 1 show that overhang can improve the MH ratio but reduce TG and increase FW80.

[0058] All references and publications cited herein are expressly incorporated herein by reference in their entirety into this disclosure except to the extent they may directly contradict this disclosure. Although specific embodiments have been illustrated and described herein, it will be appreciated by those of ordinary skill in the art that a variety of alternate and/or equivalent implementations can be substituted for the specific embodiments shown and described without departing from the scope of the present disclosure. This application is intended to cover any adaptations or variations of the specific embodiments discussed herein. Therefore, it is intended that this disclosure be limited only by the claims and the equivalents thereof. All references cited within are herein incorporated by reference in their entirety.

What is claimed is:

1. An apparatus, comprising:
  - a near-field transducer of a heat-assisted magnetic recording slider comprising:
    - a peg region formed from plasmonic material;
    - an enlarged region formed from plasmonic material and having a top side configured to contact a magnetic pole of the slider, a base side opposite the top side, and a circumference that extends from proximal an air bearing surface (ABS) of the slider to distal the ABS; and
    - a heat sink region having a contact side, a base side, and a circumference that extends from proximal the ABS to distal the ABS, wherein the contact side of the heat sink region is in physical contact with at least a region of the base side of the enlarged region, and the heat sink region is formed from plasmonic material and configured to enhance coupling efficiency of the near-field transducer;
  - wherein the circumference of the enlarged region is offset from the circumference of the heat sink region.
2. The apparatus of claim 1, wherein the circumference of the enlarged region is offset from the circumference of the heat sink region relative to the ABS.
3. The apparatus of claim 1, wherein the circumference of the enlarged region is offset from the circumference of the heat sink region in a direction away from the ABS.
4. The apparatus of claim 1, wherein a distal circumference of the enlarged region overhangs a distal circumference of the heat sink region.
5. The apparatus of claim 1, wherein an overmill region is defined between the proximal circumferences of the enlarged and heat sink regions.
6. The apparatus of claim 1, wherein an area of the top side of the enlarged region is the same as an area of the base side of the enlarged region.

7. The apparatus of claim 1, wherein an area of the contact side of the heat sink region is the same as an area of the base side of the heat sink region.

8. The apparatus of claim 1, wherein the heat sink region has a diameter of about 150 nm to about 350 nm.

9. The apparatus of claim 1, wherein the heat sink region has a diameter of about 240 nm to about 300 nm.

10. The apparatus of claim 1, wherein the heat sink region has a thickness of about 30 nm to about 50 nm.

11. An apparatus, comprising:

a slider of a heat-assisted magnetic recording head comprising:

a writer comprising a write pole;

an optical waveguide; and

a near-field transducer optically coupled to the optical waveguide, the near-field transducer comprising:

a peg formed from plasmonic material;

an enlarged disk formed from plasmonic material and having a top side configured to contact the write pole of the writer, a base side opposite the top side, and a circumference that extends from proximal an air bearing surface (ABS) of the slider to distal the ABS; and

a heat sink disk having a contact side, a base side, and a circumference that extends from proximal the ABS to distal the ABS, wherein the contact side of the heat sink disk is in physical contact with at least a region of the base side of the enlarged disk, and the heat sink disk is formed from plasmonic material and configured to enhance coupling efficiency of the near-field transducer;

wherein the circumference of the enlarged disk is offset from the circumference of the heat sink disk.

12. The apparatus of claim 11, wherein the circumference of the enlarged disk is offset from the circumference of the heat sink disk relative to the ABS.

13. The apparatus of claim 11, wherein the circumference of the enlarged disk is offset from the circumference of the heat sink disk in a direction away from the ABS.

14. The apparatus of claim 11, wherein a distal circumference of the enlarged disk overhangs a distal circumference of the heat sink disk.

15. The apparatus of claim 11, wherein an overmill region is defined between the proximal circumferences of the enlarged and heat sink disks.

16. The apparatus of claim 11, wherein an area of the top side of the enlarged disk is the same as an area of the base side of the enlarged disk.

17. The apparatus of claim 11, wherein an area of the contact side of the heat sink disk is the same as an area of the base side of the heat sink disk.

18. The apparatus of claim 11, wherein the heat sink disk has a diameter of about 150 nm to about 350 nm.

19. The apparatus of claim 11, wherein the heat sink disk has a diameter of about 240 nm to about 300 nm.

20. The apparatus of claim 11, wherein the heat sink disk has a thickness of about 30 nm to about 50 nm.

\* \* \* \* \*