



US 20180199655A1

(19) **United States**

(12) **Patent Application Publication**  
**LYTTLE et al.**

(10) **Pub. No.: US 2018/0199655 A1**

(43) **Pub. Date: Jul. 19, 2018**

(54) **COMPOSITE UPPER FOR SHOE WITH SELECTIVELY DISPOSED BONDING AGENT**

(52) **U.S. Cl.**

CPC ..... *A43B 1/00* (2013.01); *A43B 23/026* (2013.01); *A43B 23/0255* (2013.01); *A43B 23/0235* (2013.01); *A43B 23/0295* (2013.01); *B32B 7/14* (2013.01); *Y10T 156/1062* (2015.01); *Y10T 428/24851* (2015.01); *A41D 31/02* (2013.01)

(71) Applicant: **NIKE, Inc.**, Beaverton, OR (US)

(72) Inventors: **Amy LYTTLE**, Beaverton, OR (US);  
**Todd W. MILLER**, Portland, OR (US)

(21) Appl. No.: **15/920,642**

(57) **ABSTRACT**

(22) Filed: **Mar. 14, 2018**

Footwear fabrication methods are disclosed, having reduced material consumption and/or waste requirements, compared to conventional methods, as well as the footwear articles made by such methods. The fabrication methods and articles are characterized by the selective use of a bonding agent, in the form of a powder or tackified (e.g., preheated) powder, to bond various material panels, such substrate, mesh, and/or skin panels in the formation of a composite panel (e.g., a bonded mesh composite panel), which may in turn be used to provide a footwear upper and ultimately an article of footwear. The bonding agent is particularly applicable to fabrication processes utilizing a combination of heat and pressure for bonding or fusing material panels, each having a suitable composition, size, shape, and thickness, into the particular configuration of the footwear upper.

**Related U.S. Application Data**

(62) Division of application No. 15/075,372, filed on Mar. 21, 2016, now Pat. No. 9,949,524, which is a division of application No. 13/599,610, filed on Aug. 30, 2012, now Pat. No. 9,320,312.

**Publication Classification**

(51) **Int. Cl.**

*A43B 1/00* (2006.01)  
*A43B 23/02* (2006.01)  
*A41D 31/02* (2006.01)  
*B32B 7/14* (2006.01)

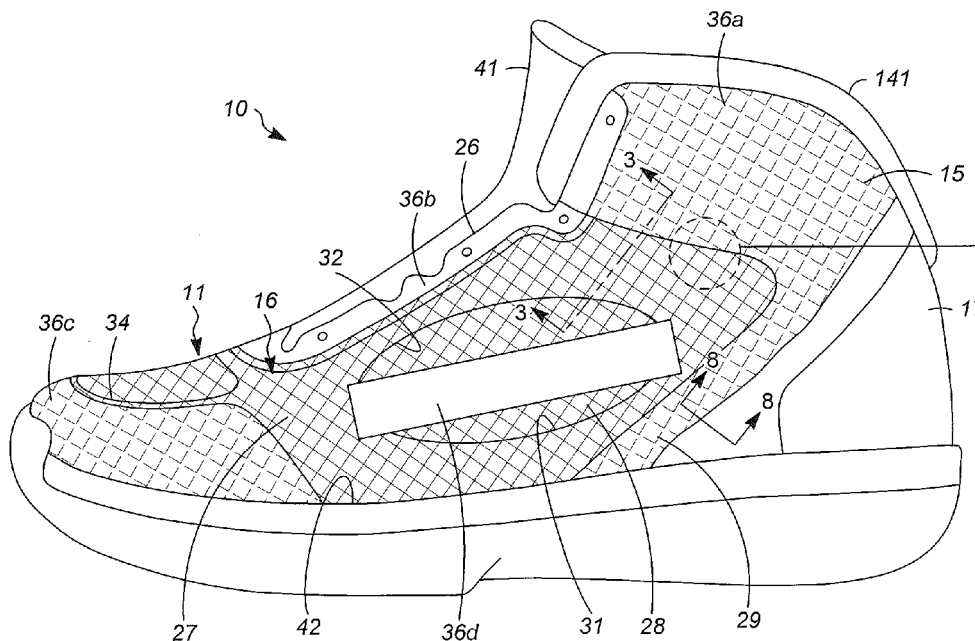

**FIG. 1C**



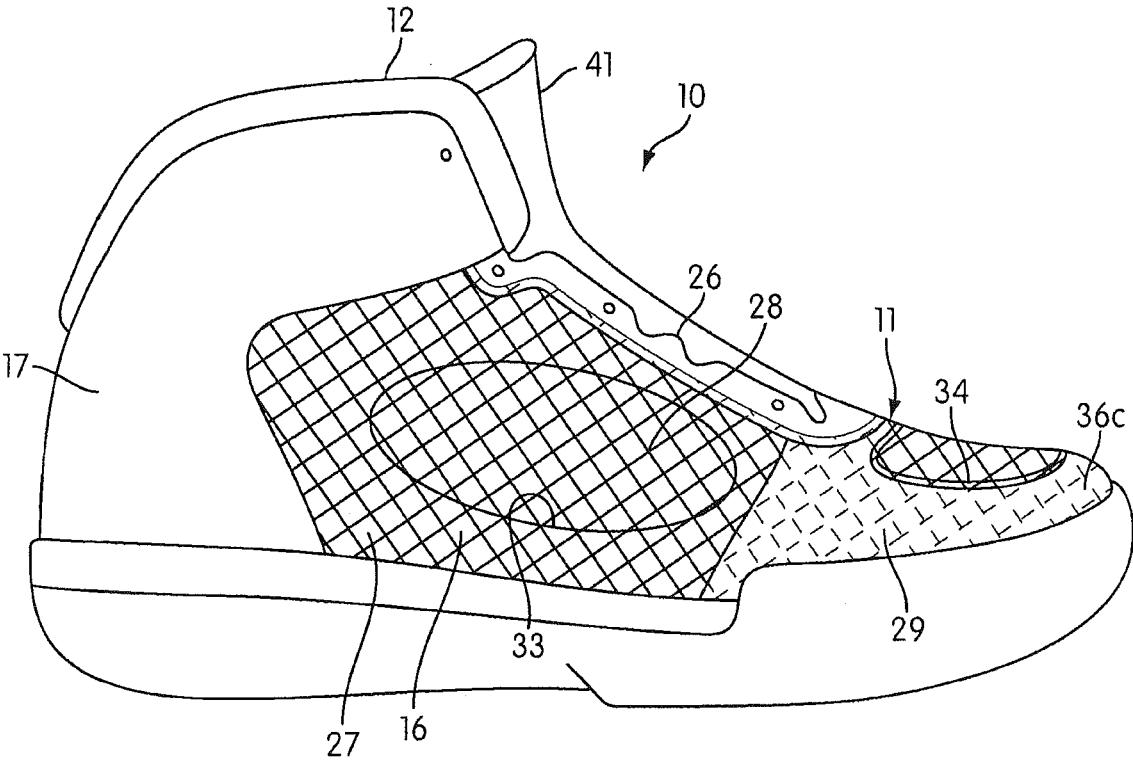

FIG. 1B

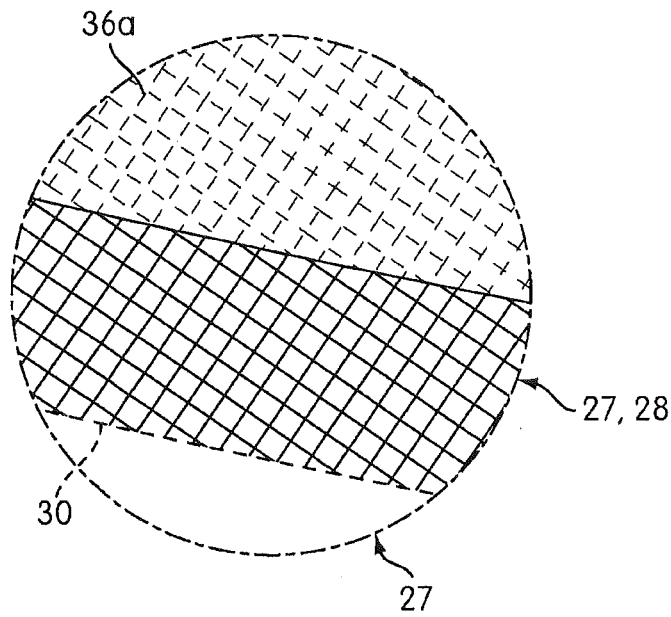

FIG. 1C

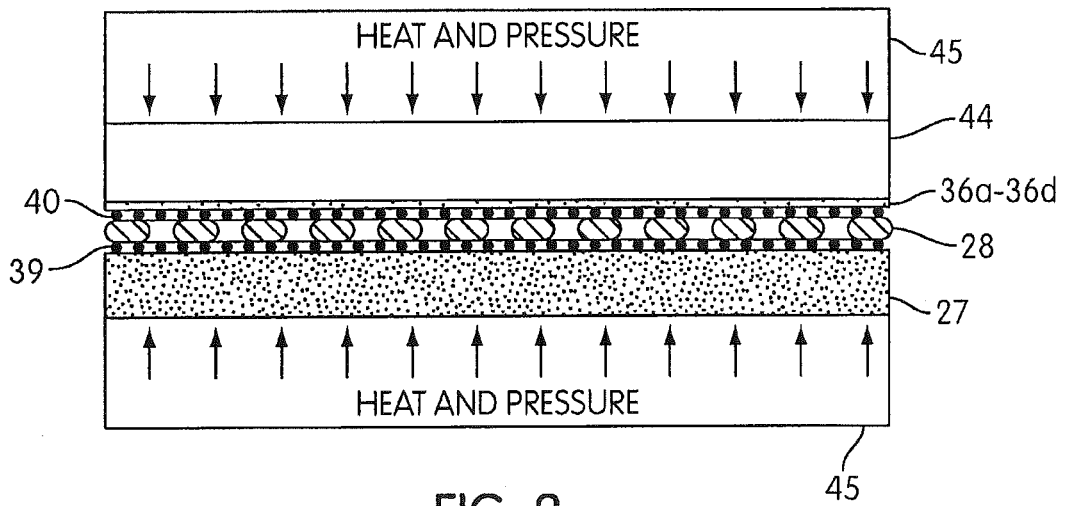

FIG. 2

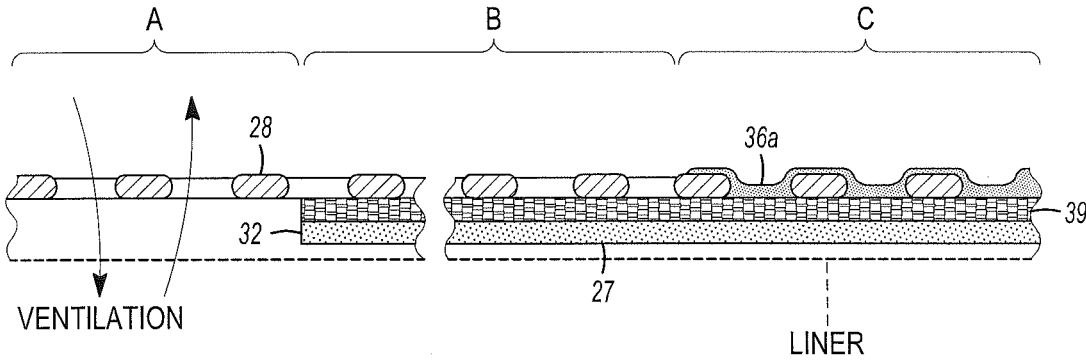

FIG. 3

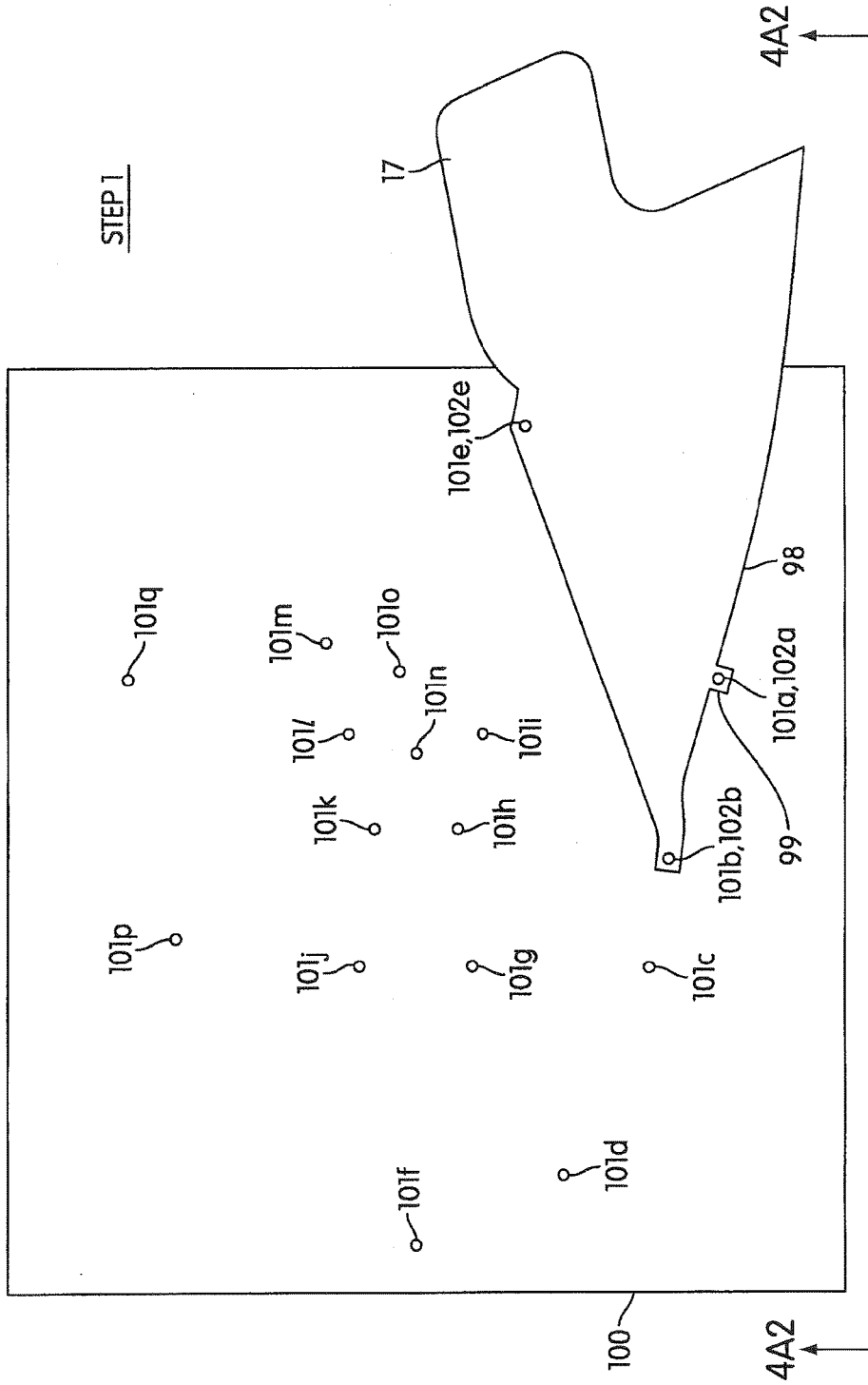

FIG. 4A1

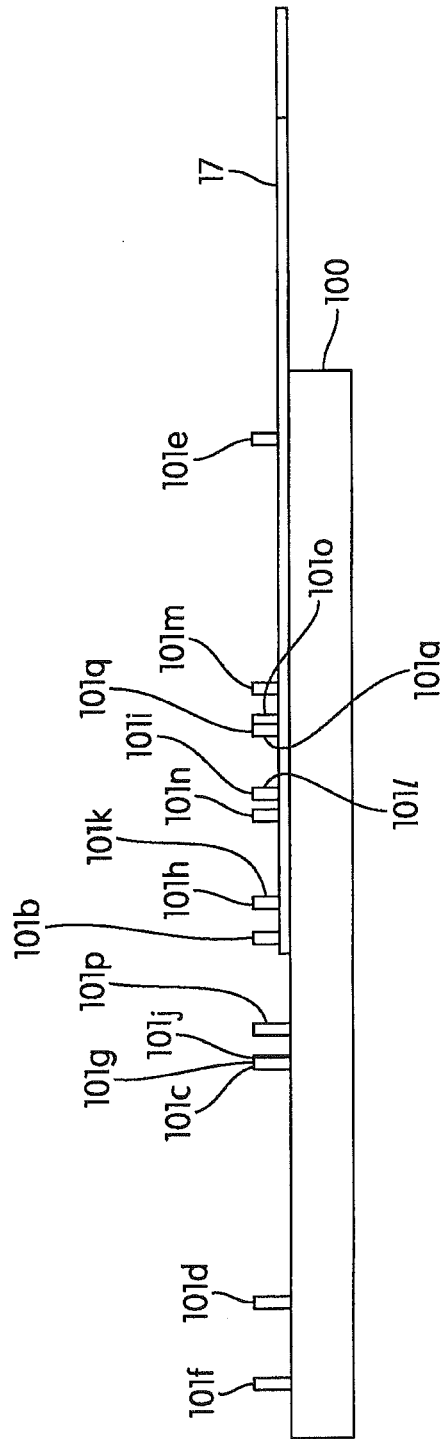

FIG. 4A2

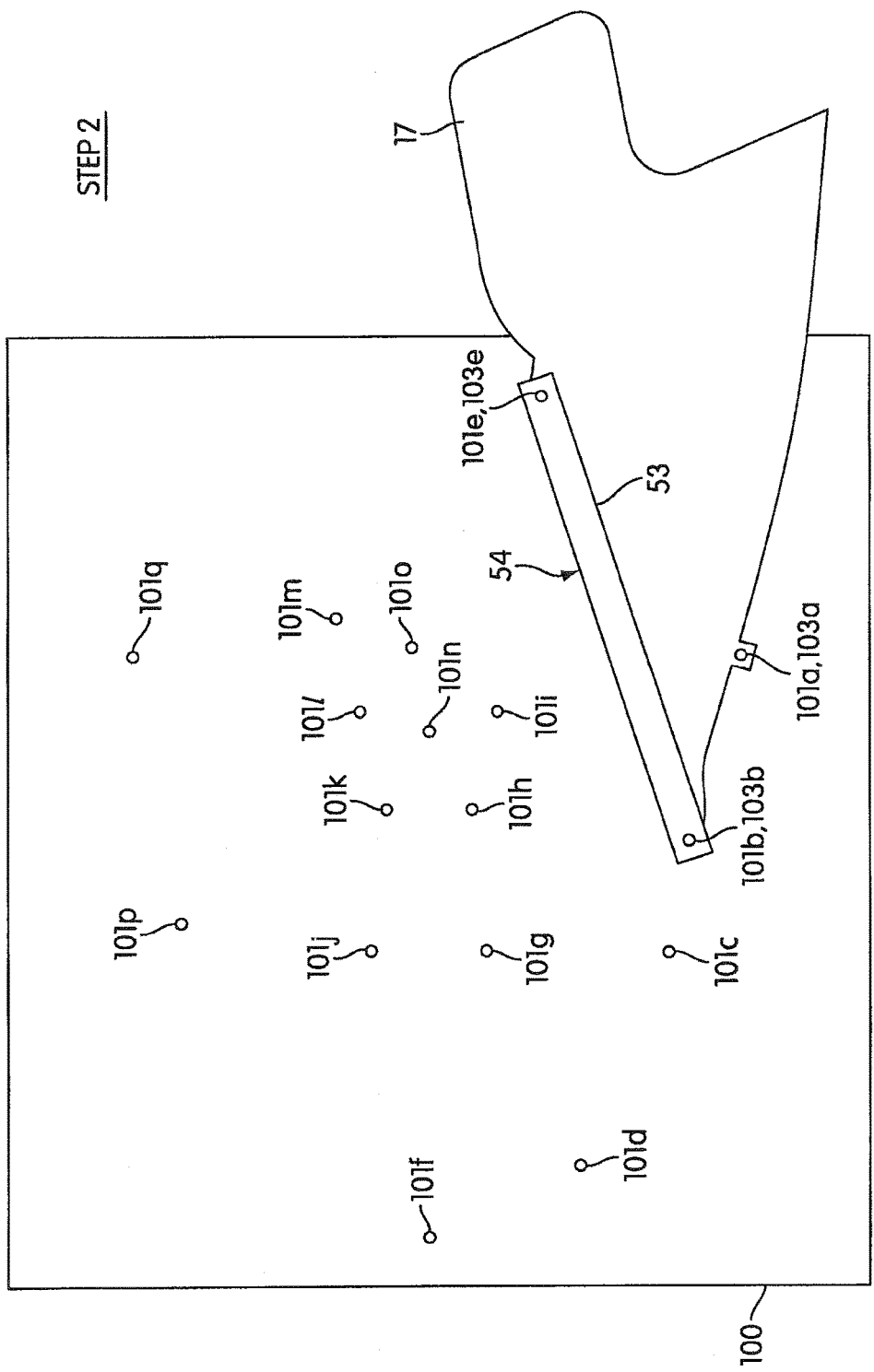

FIG. 4B



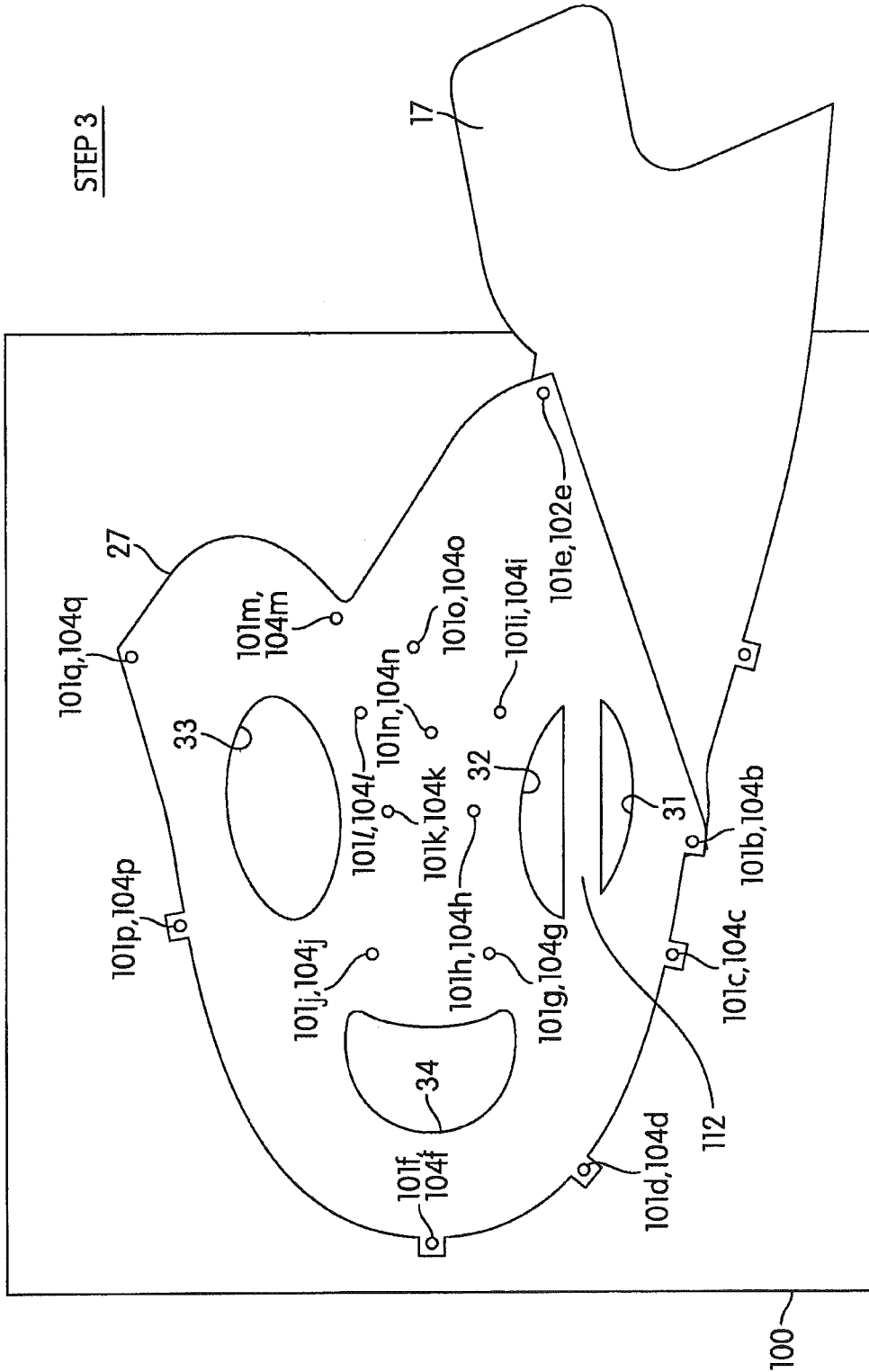

FIG. 4C

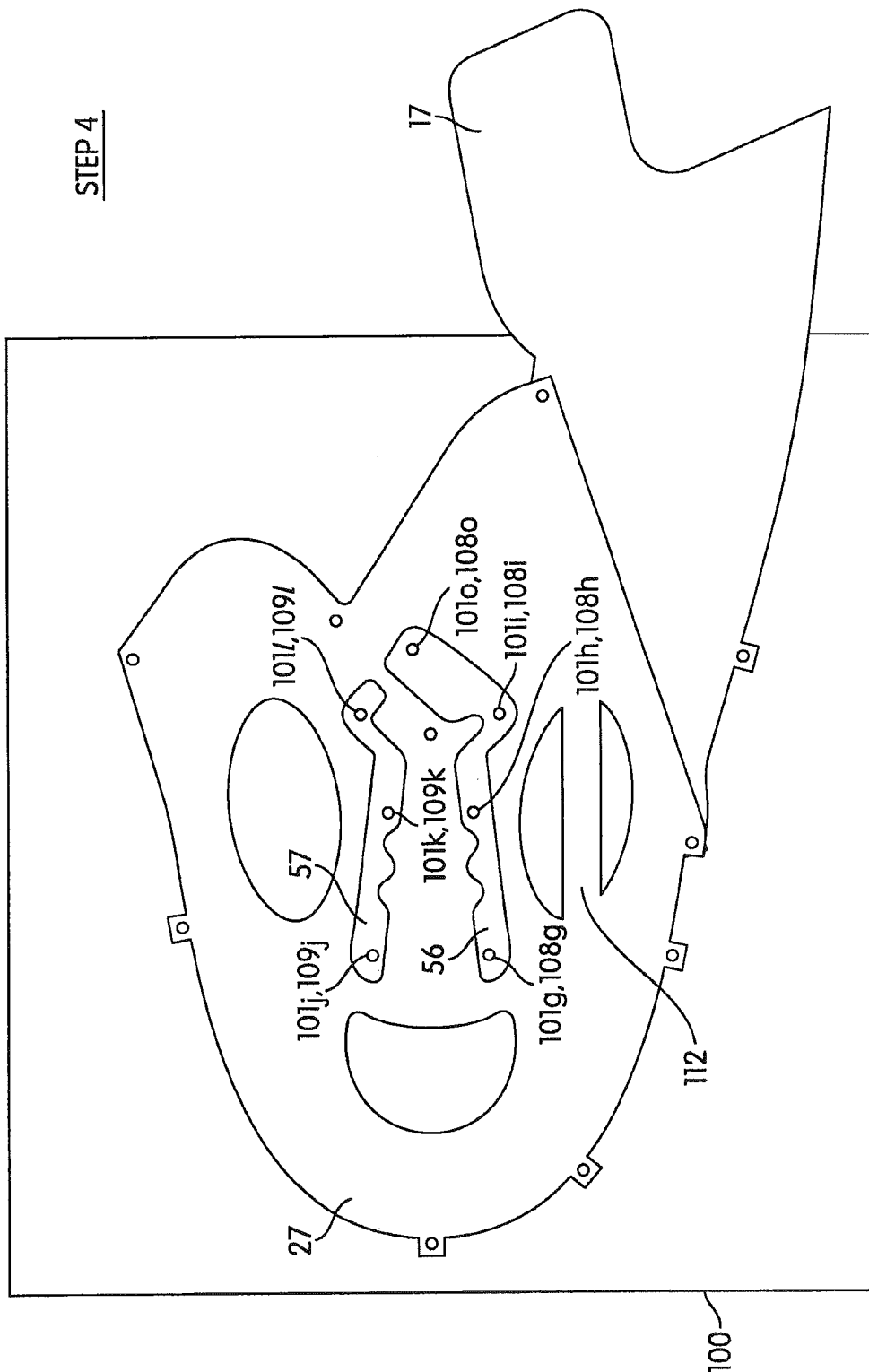

FIG. 4D

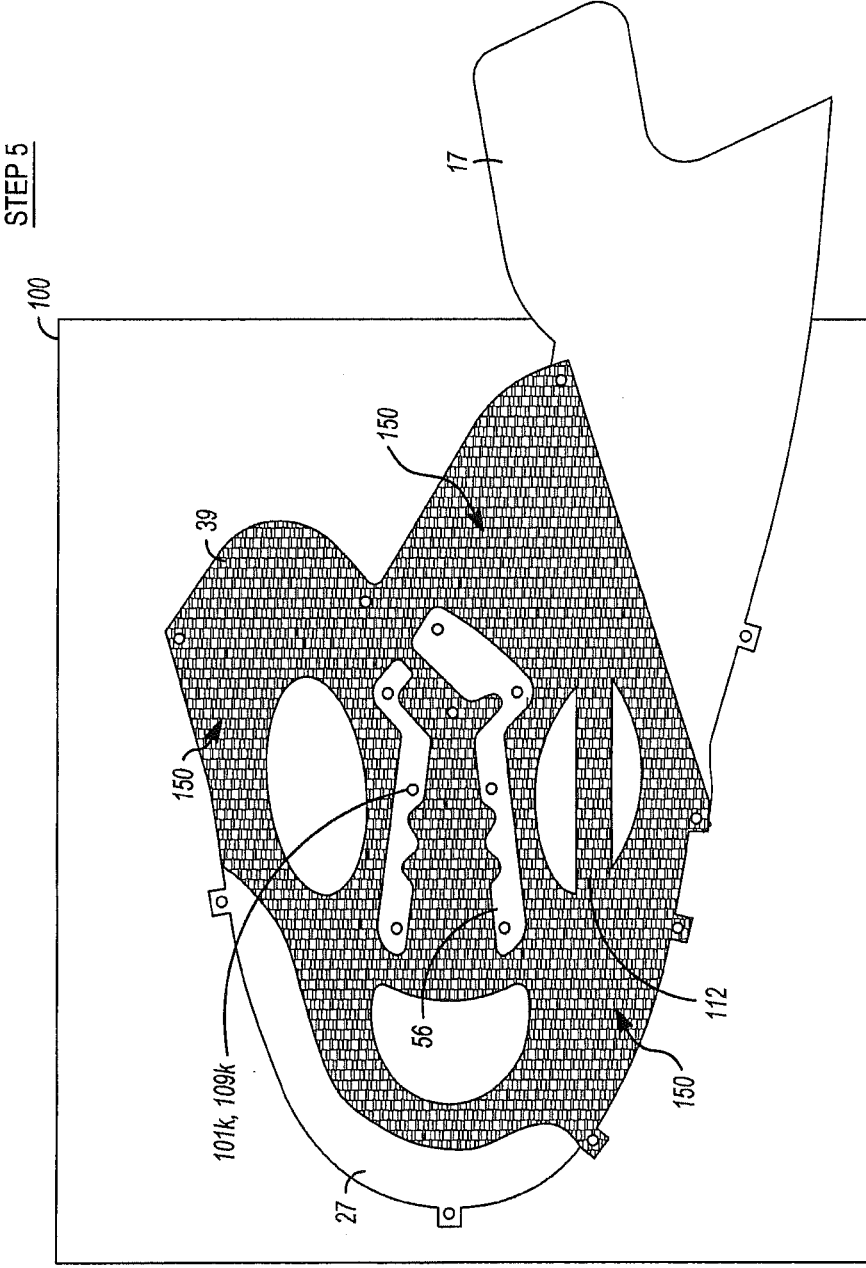

FIG. 4E

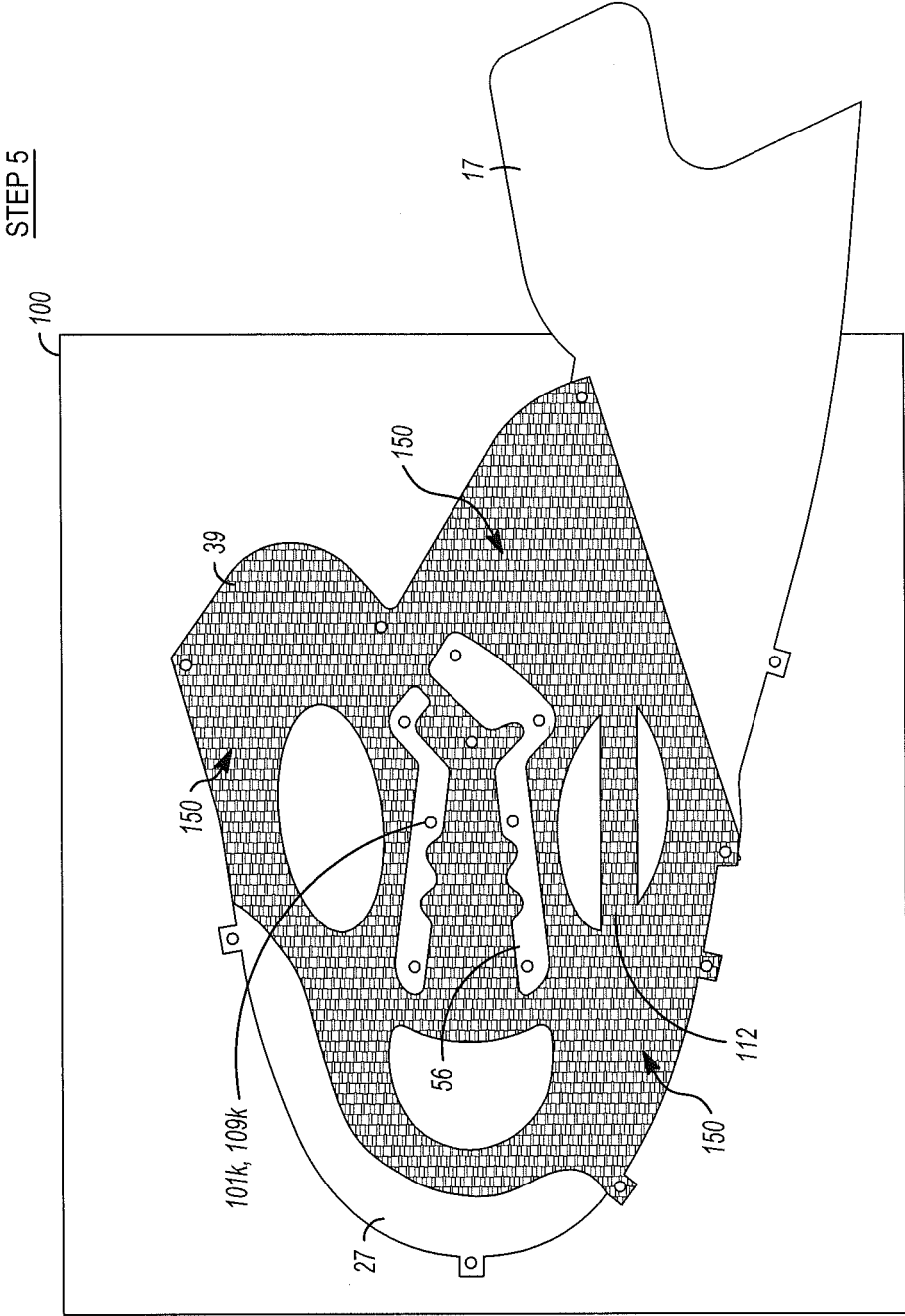

FIG. 4E1

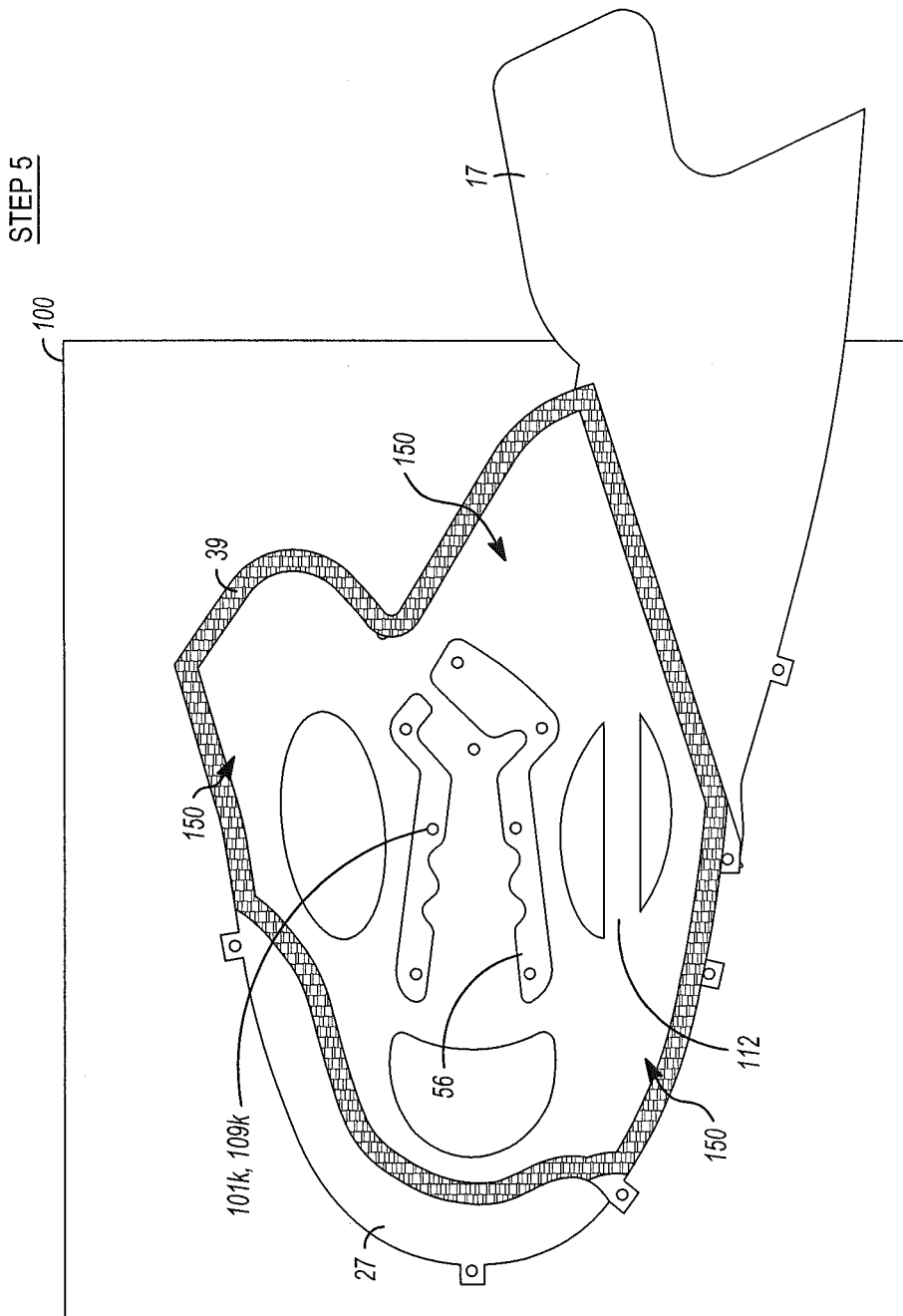

FIG. 4E2

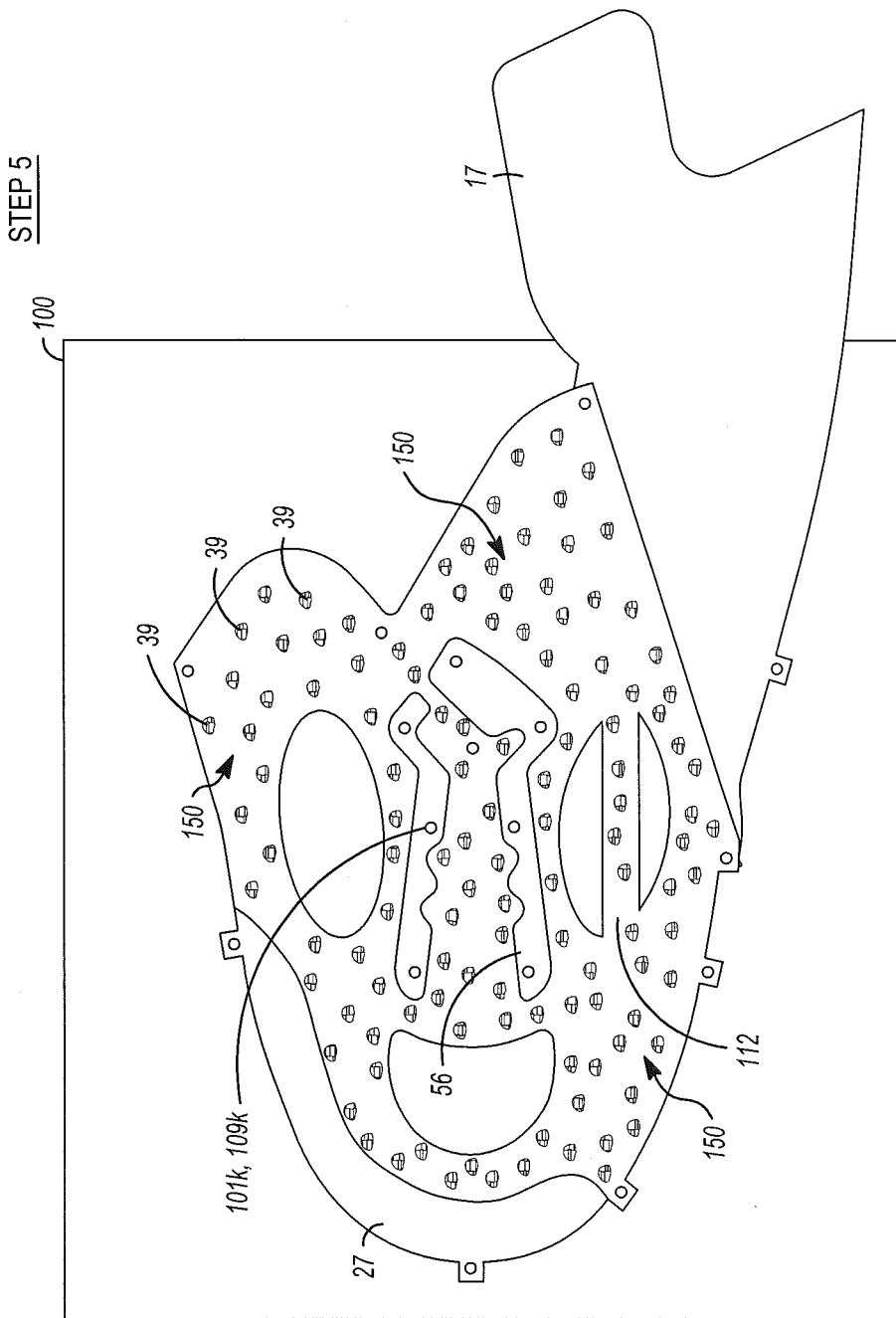

FIG. 4E3

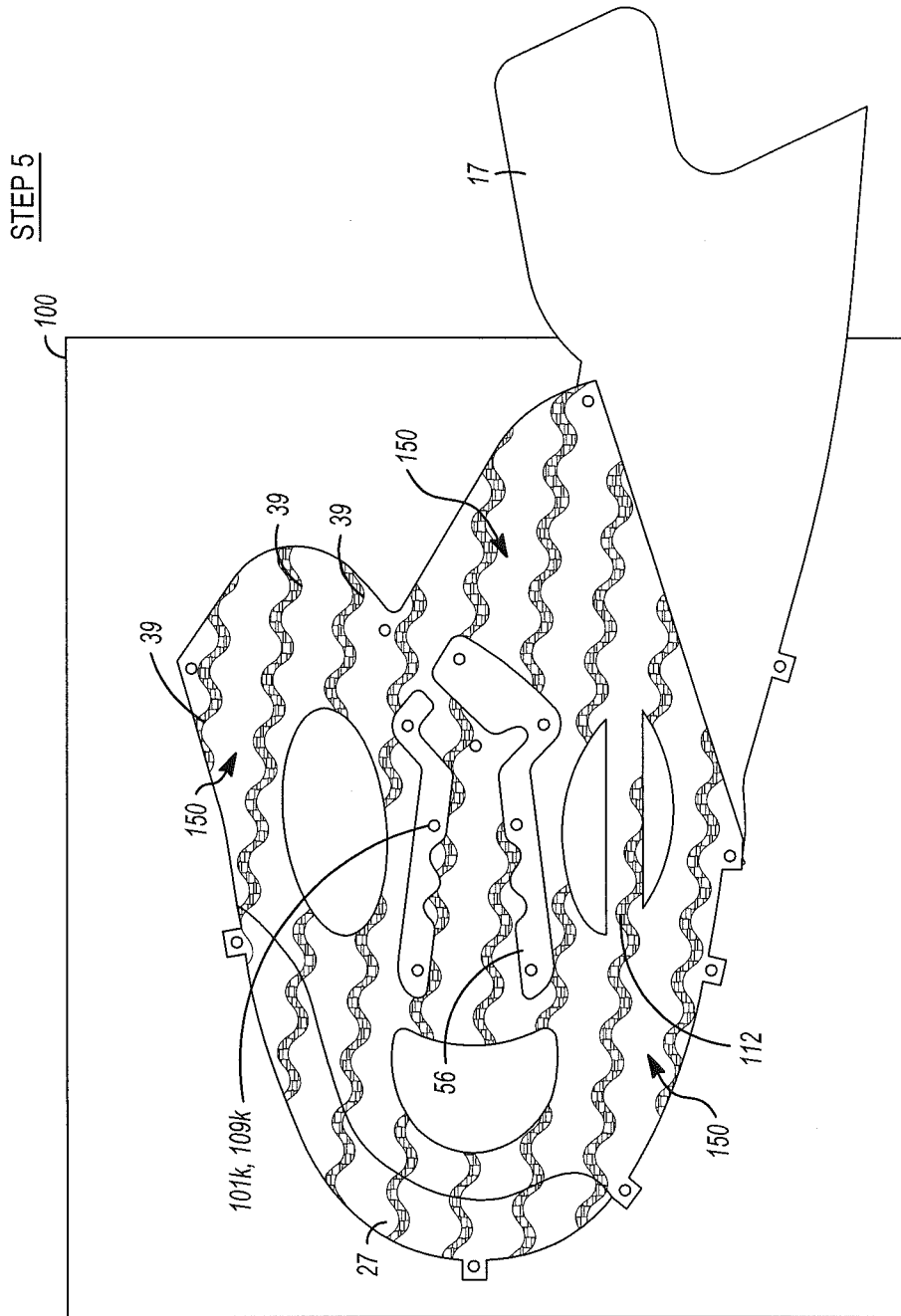

FIG. 4E4

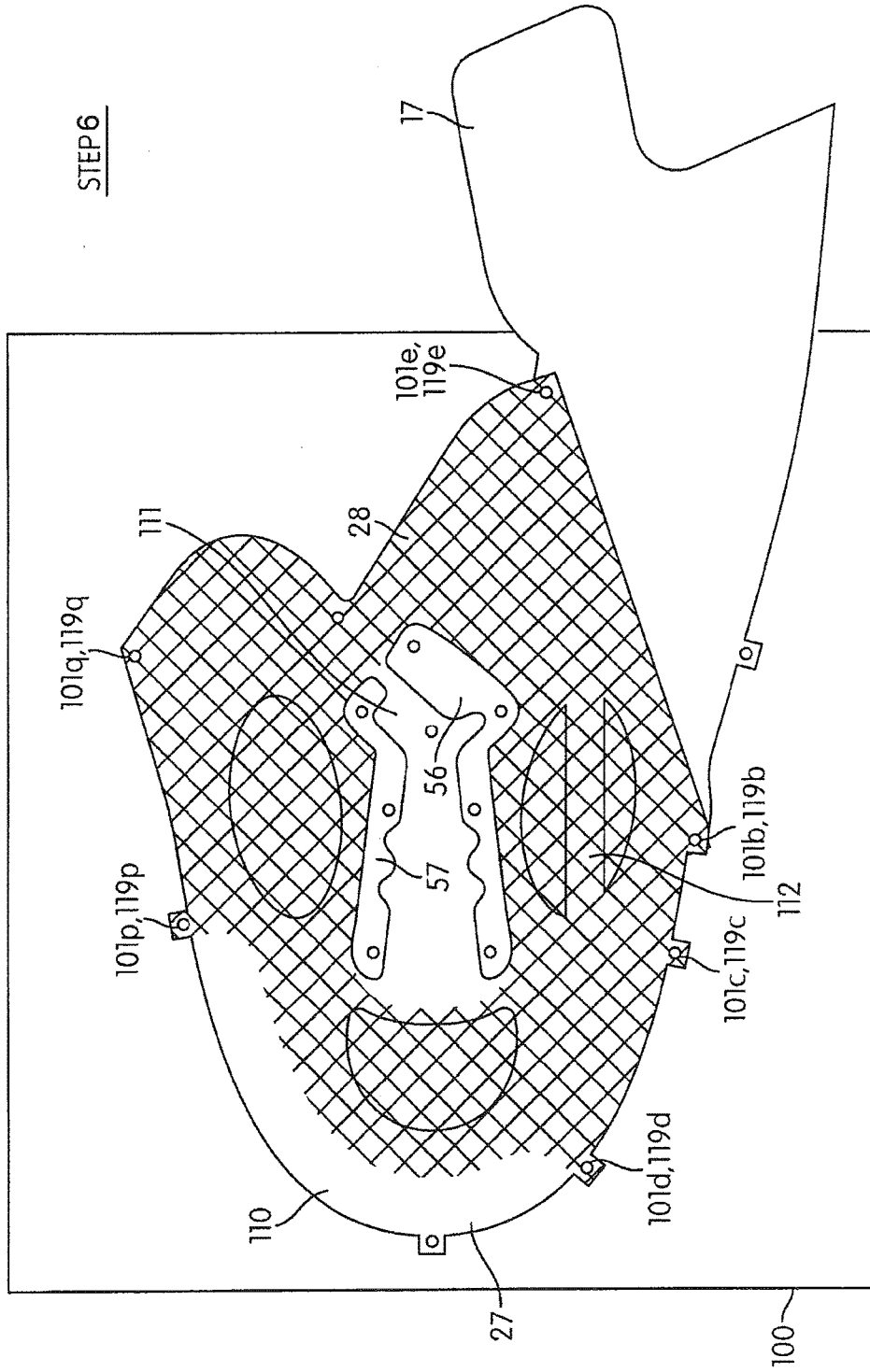

FIG. 4F



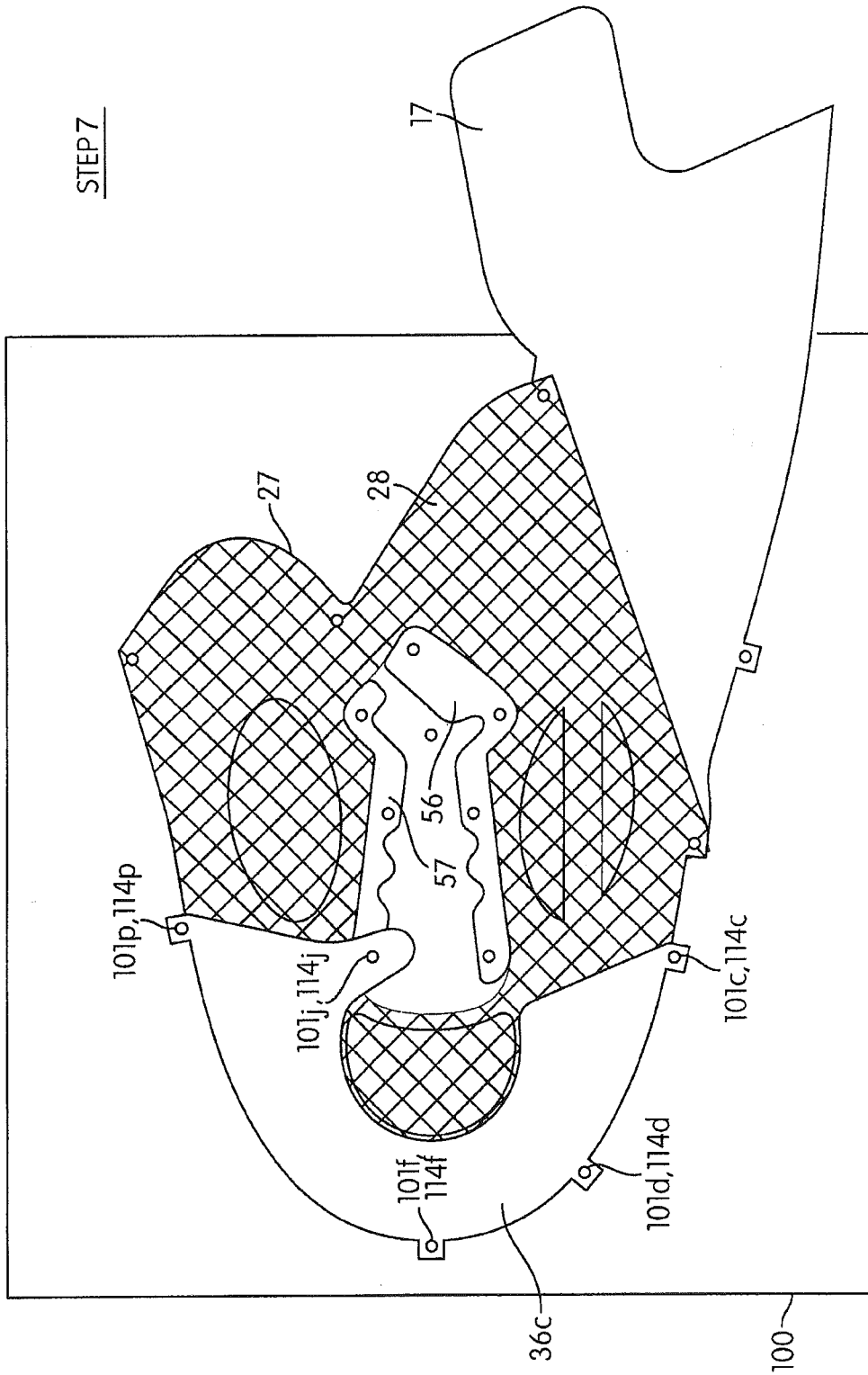

FIG. 4G

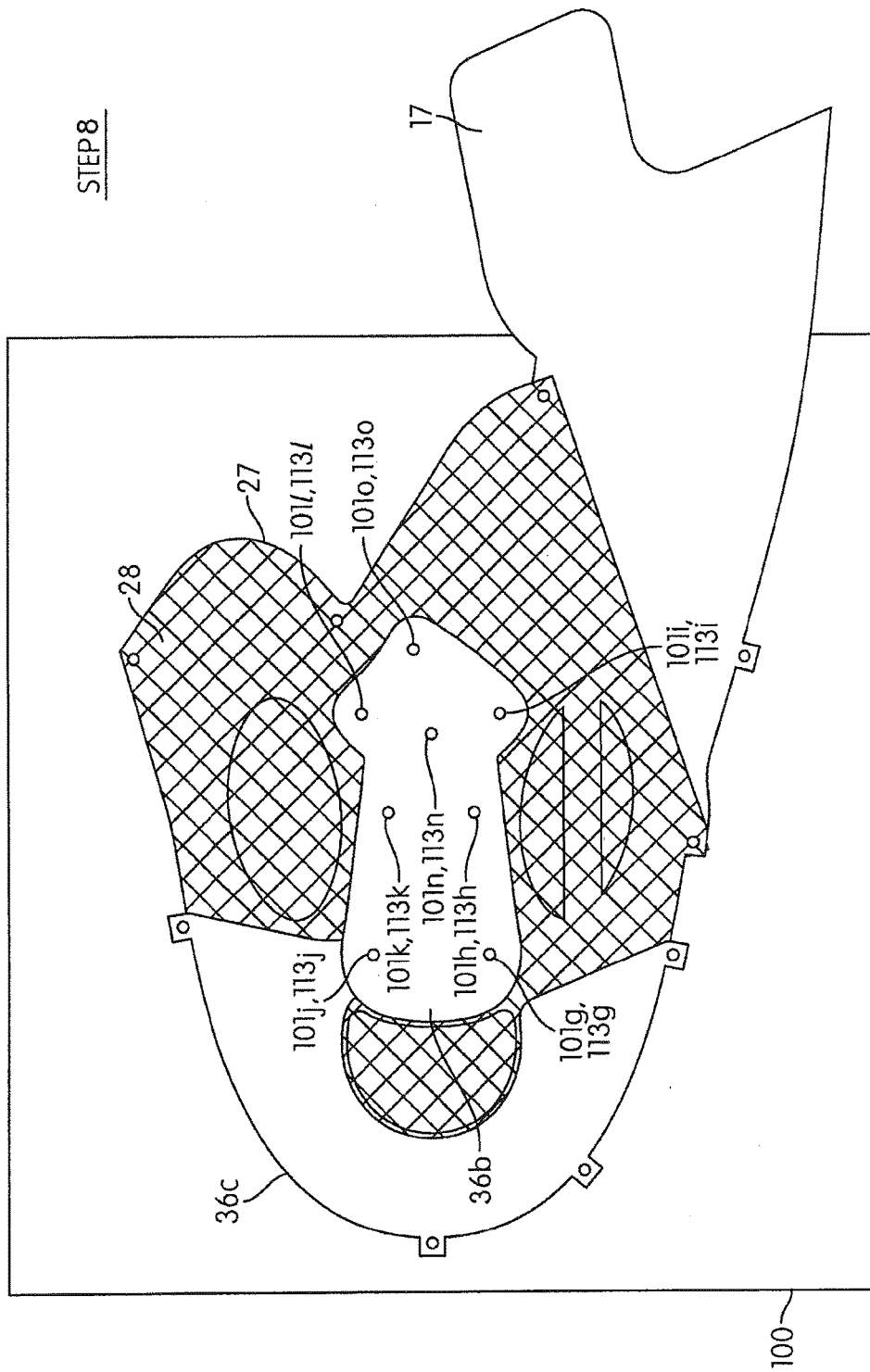

FIG. 4H

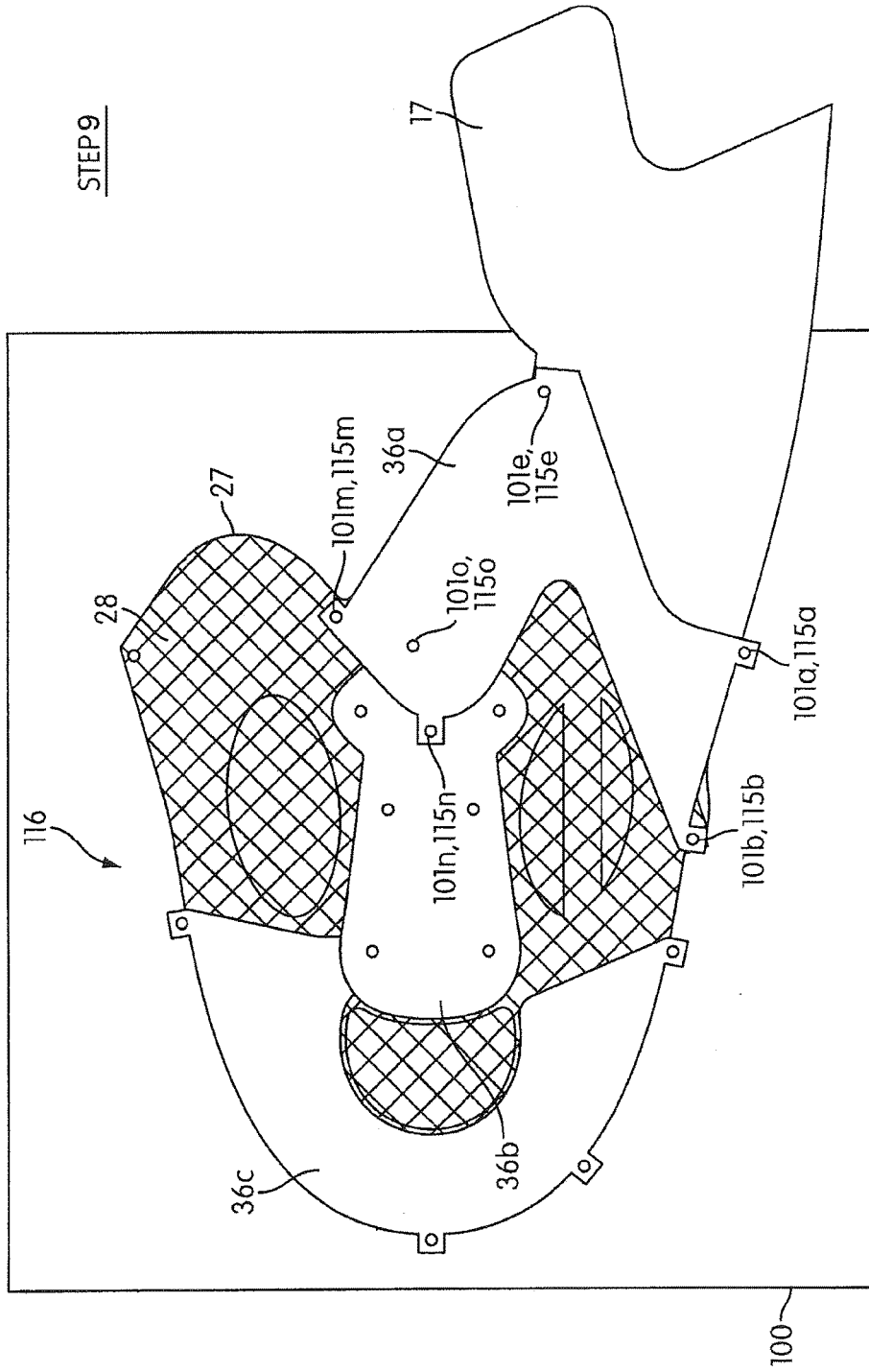

FIG. 4I

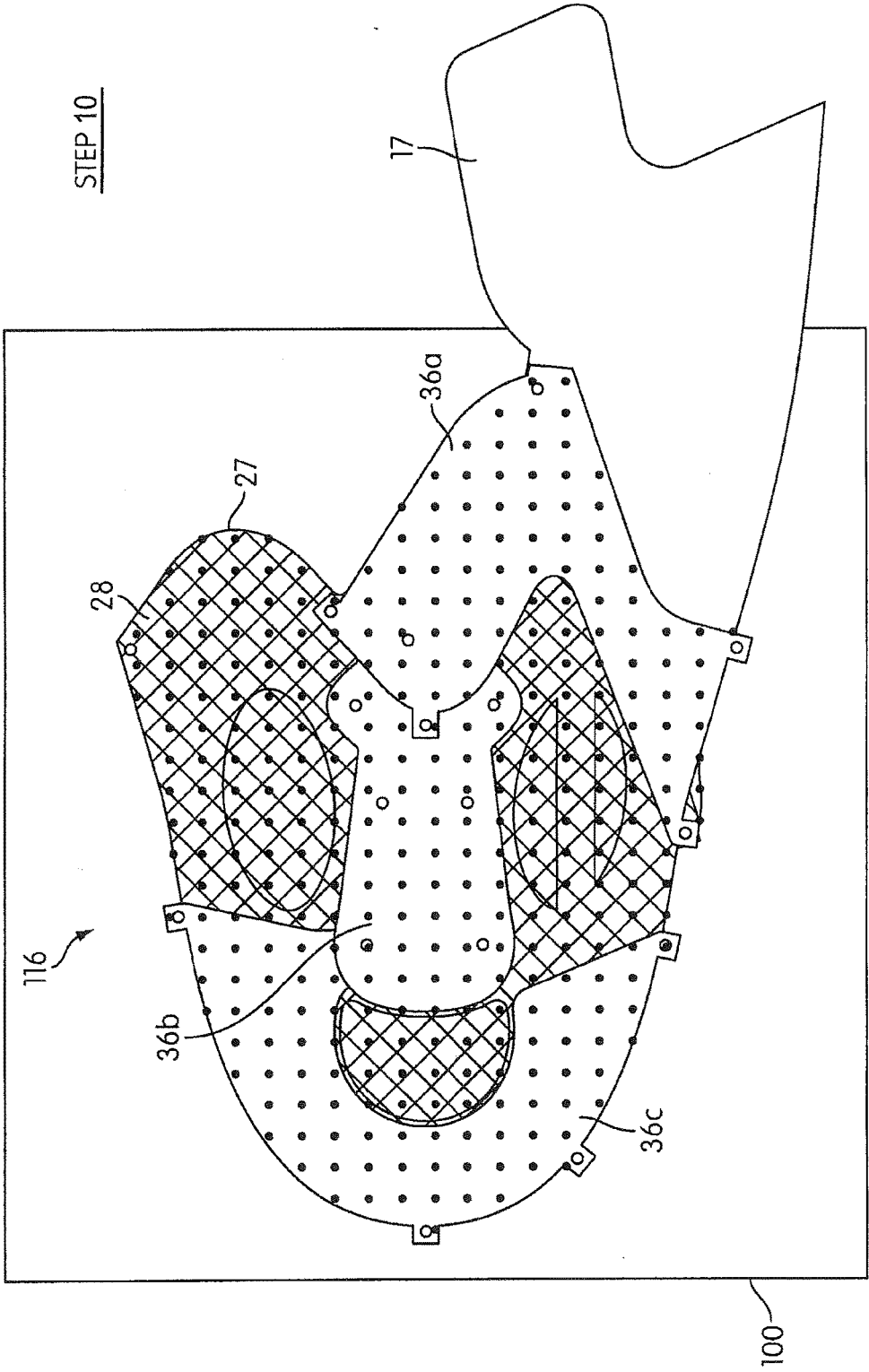

FIG. 4J

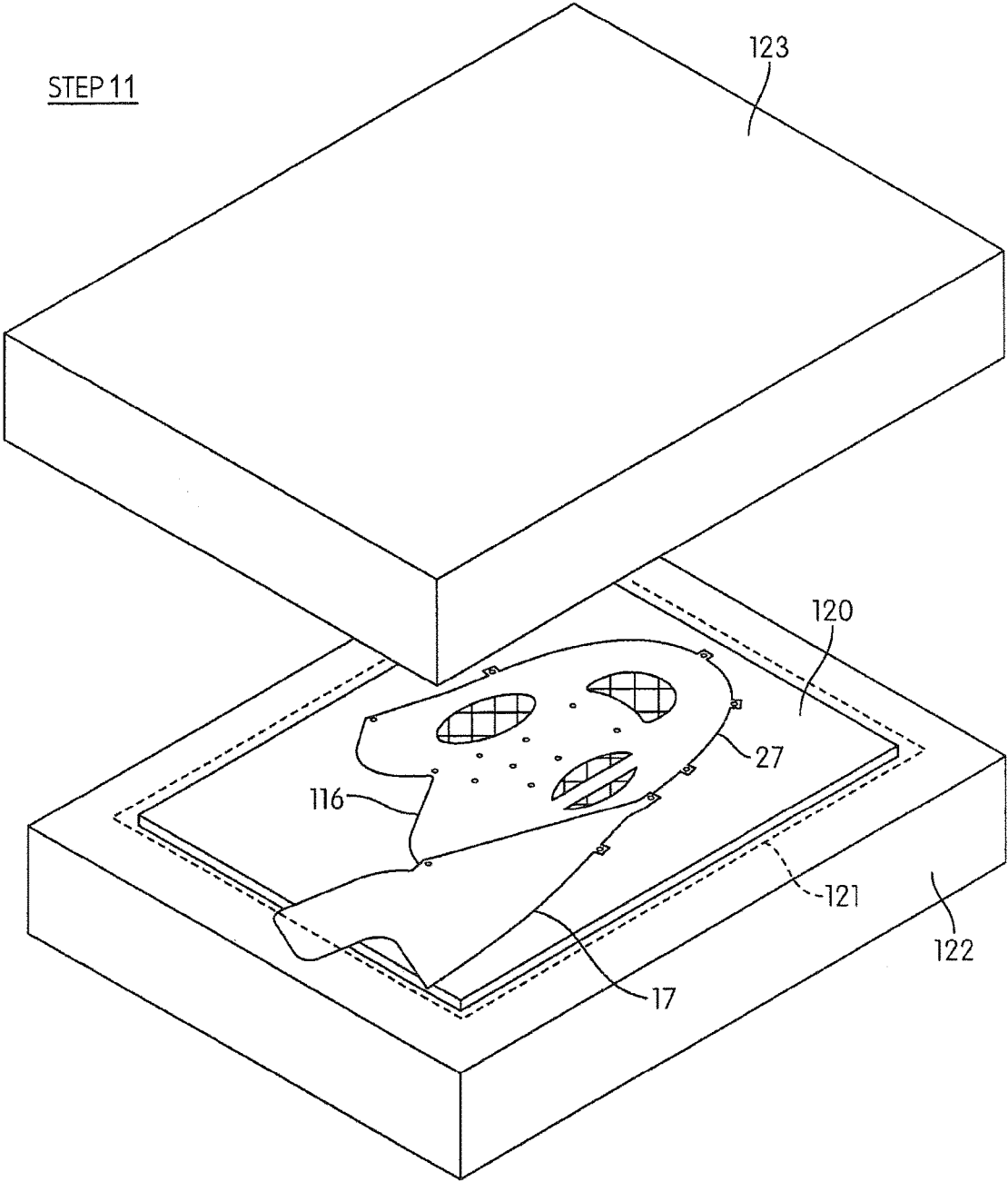

FIG. 4K

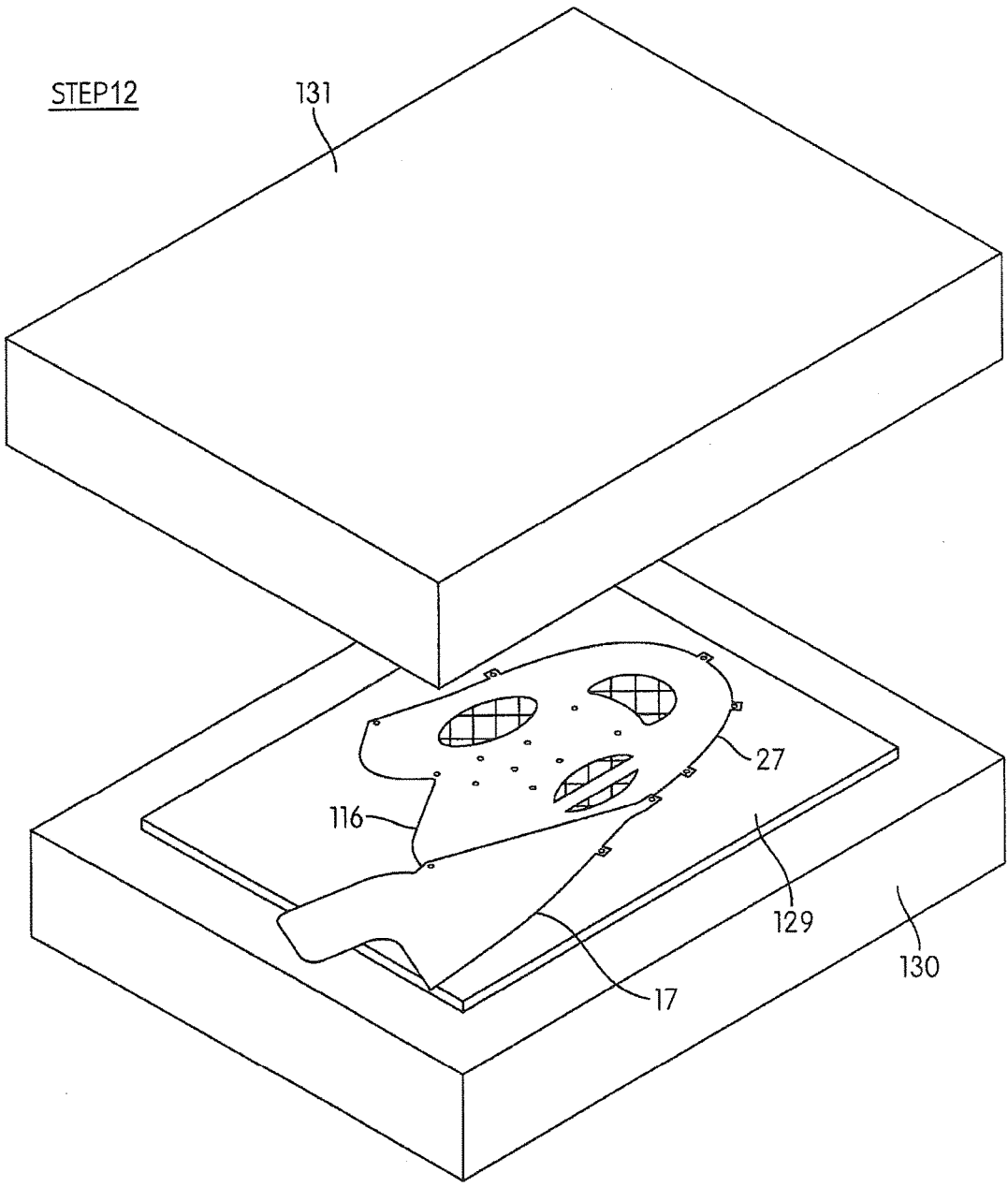

FIG. 4L

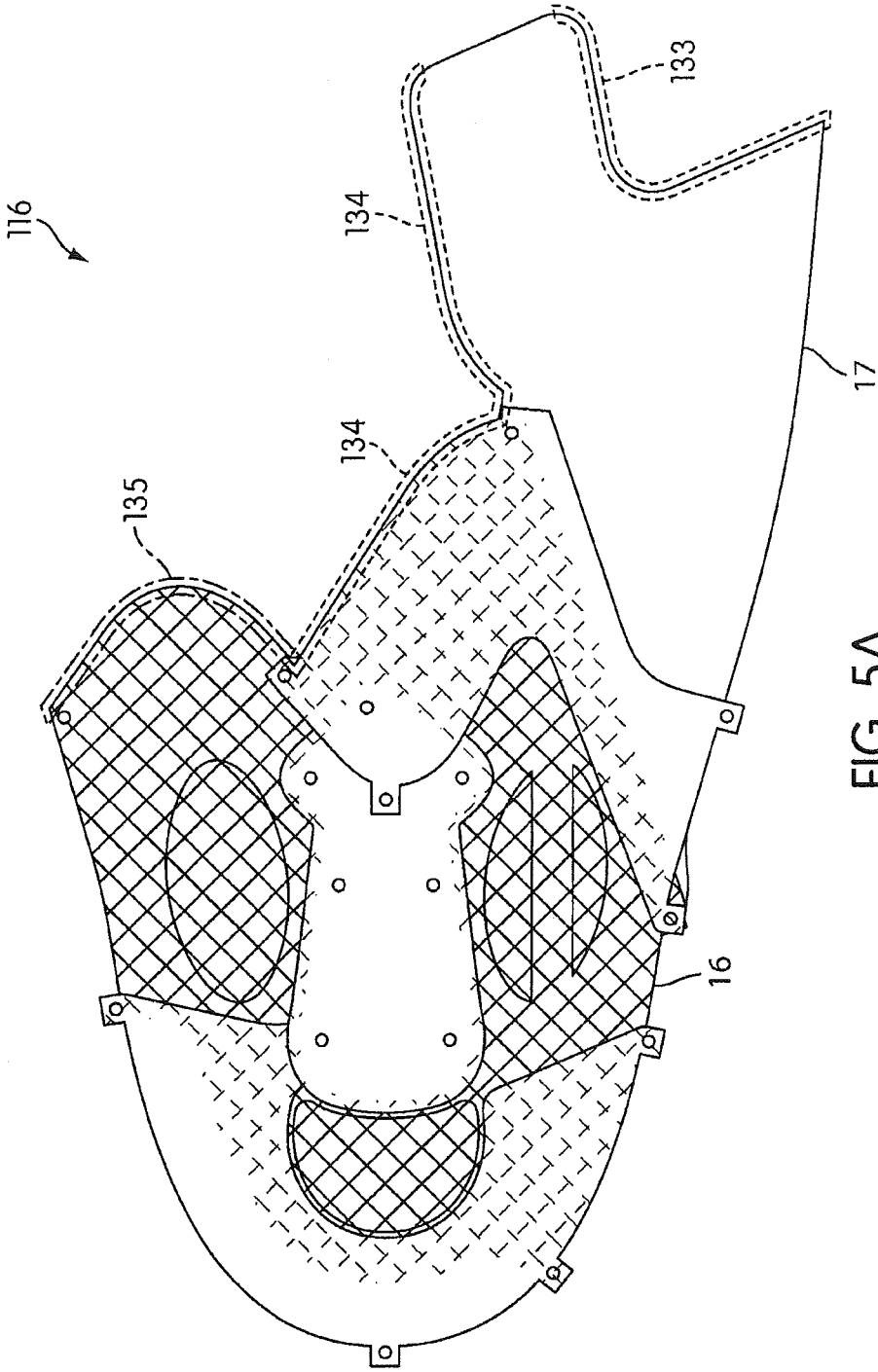

FIG. 5A

STEP 13

116

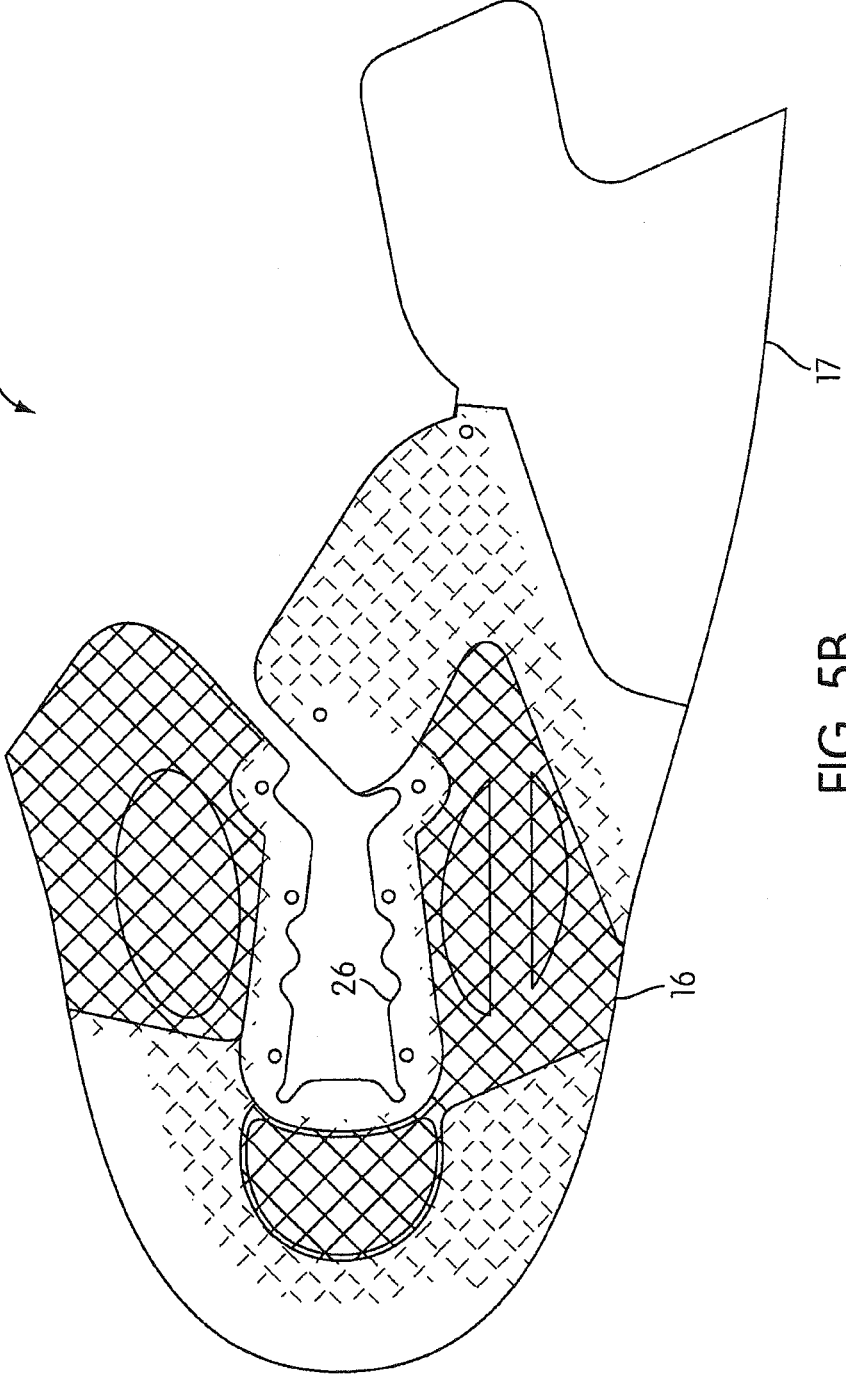

FIG. 5B



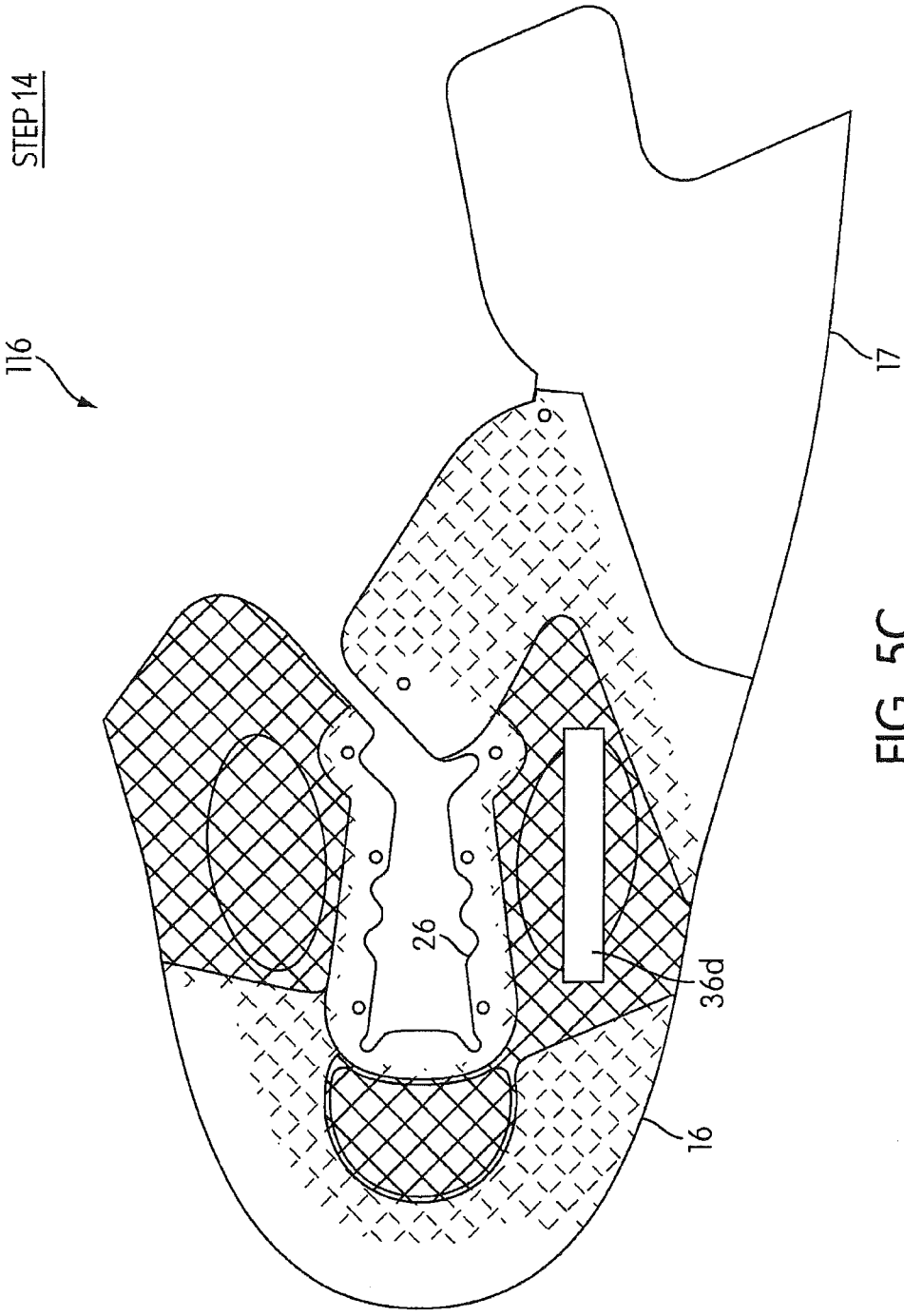

FIG. 5C

STEP 15

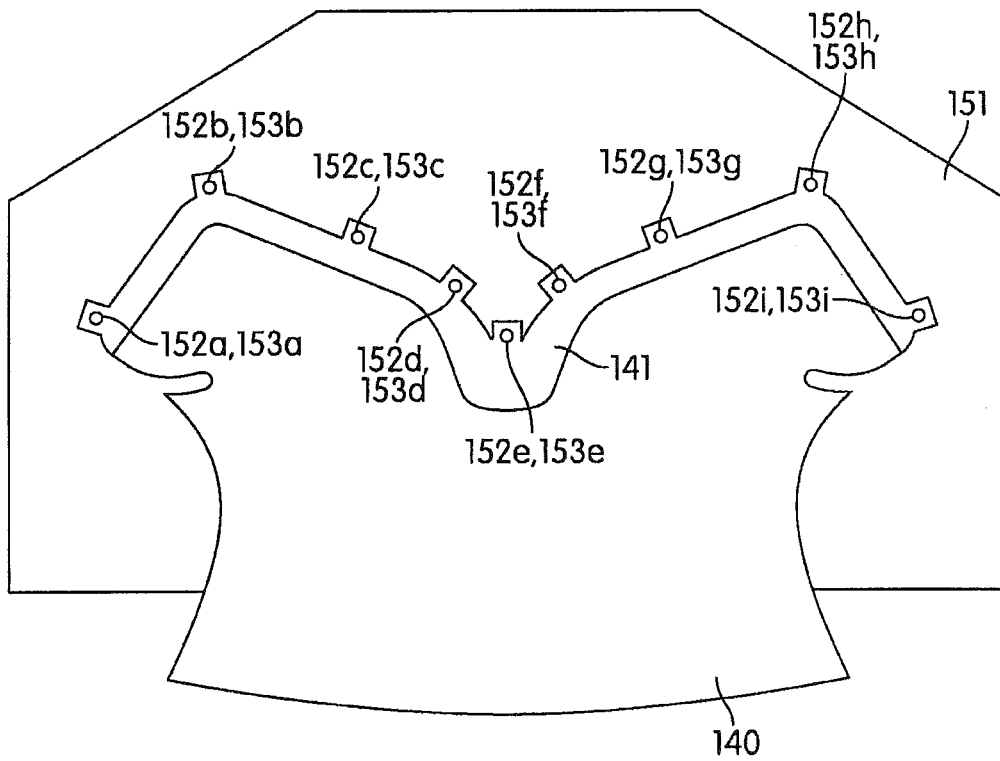

FIG. 5D

STEP 16

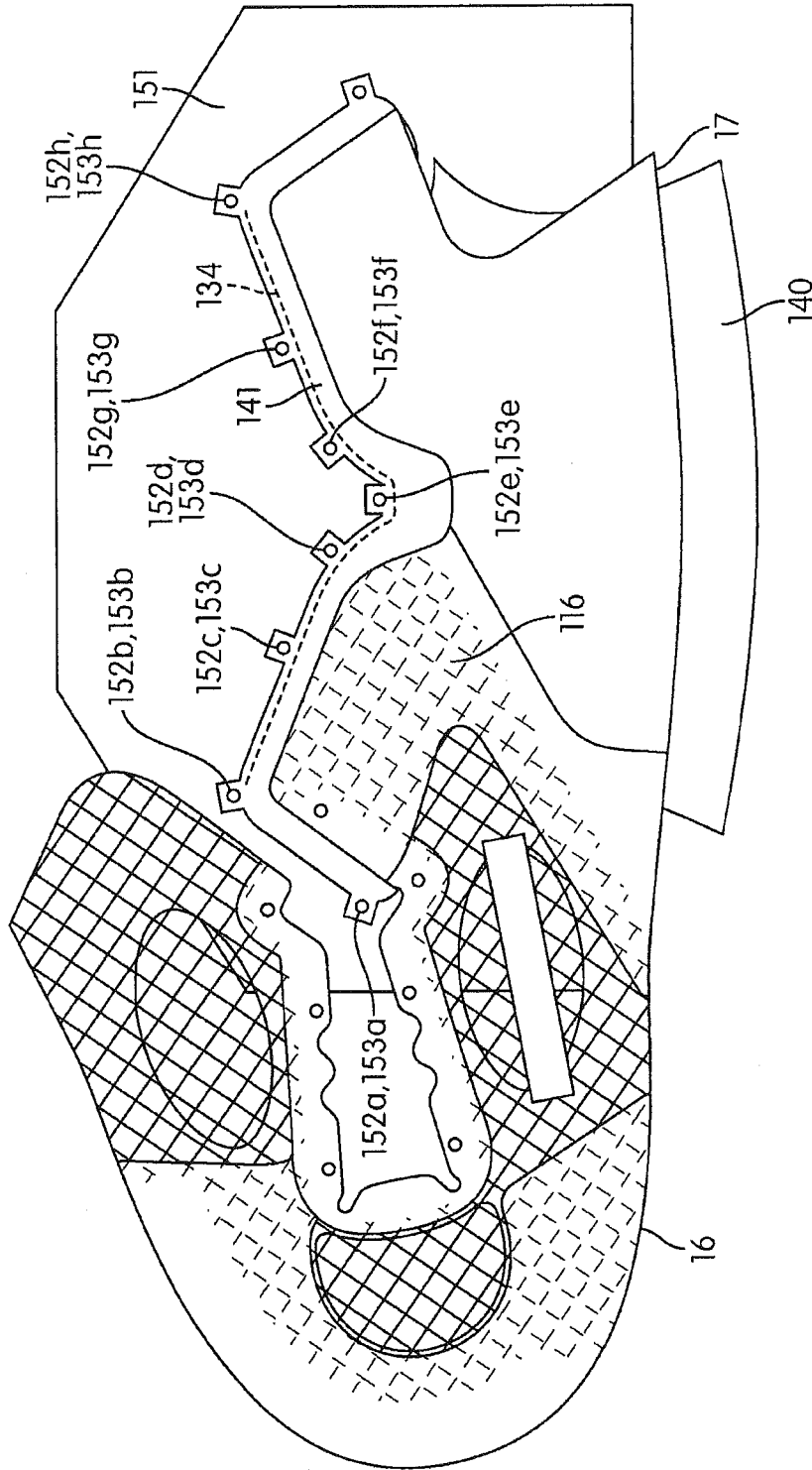

FIG. 5E

STEP 17

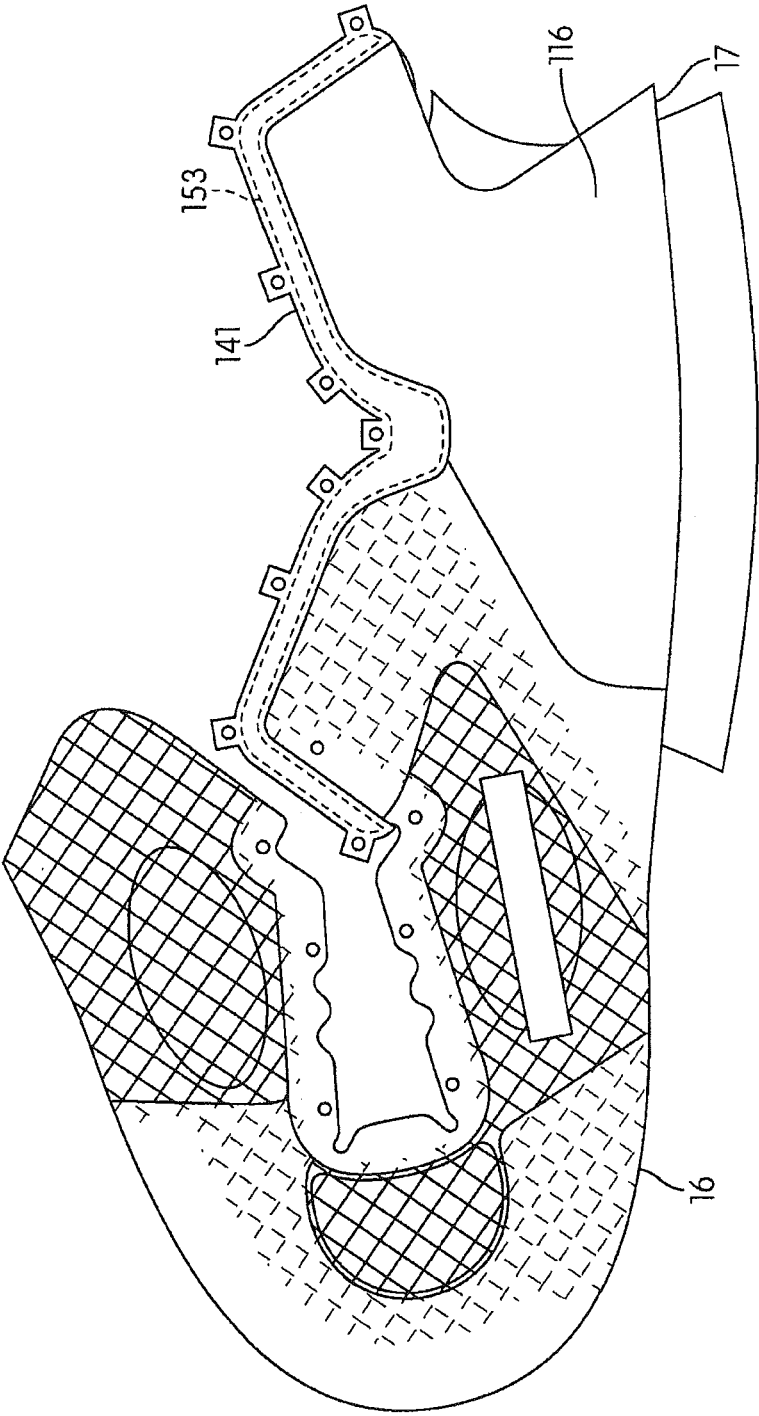

FIG. 5F

STEP 18

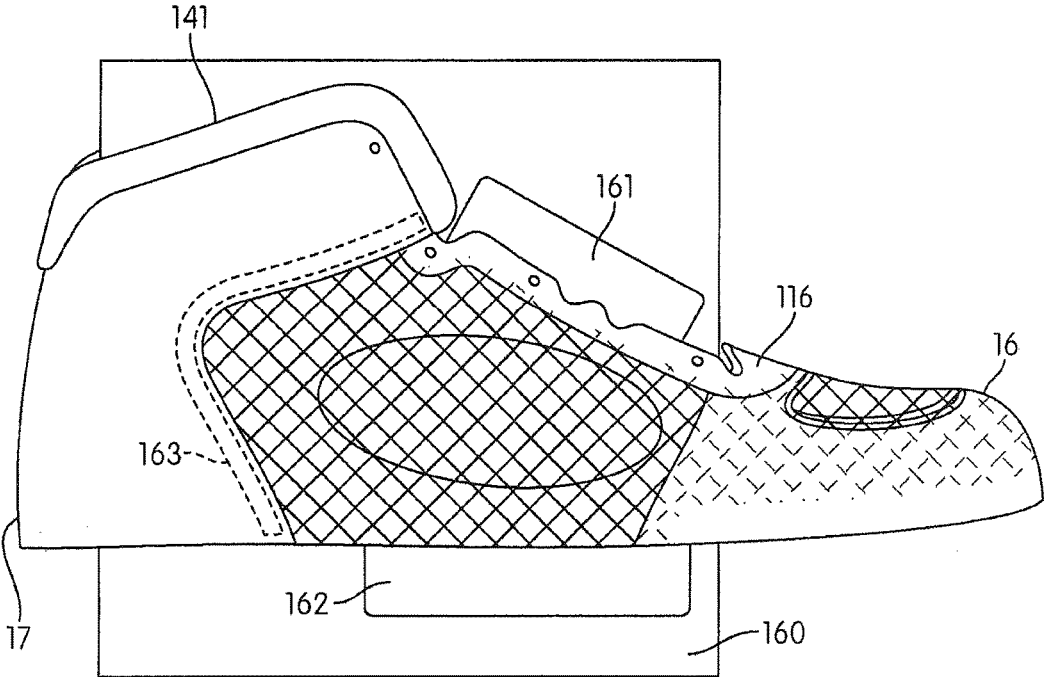

FIG. 5G

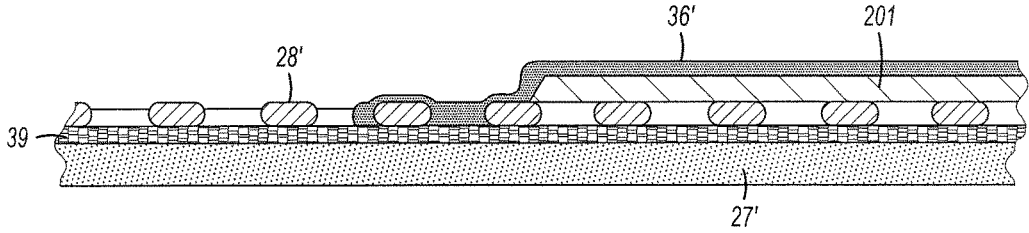

FIG. 6A

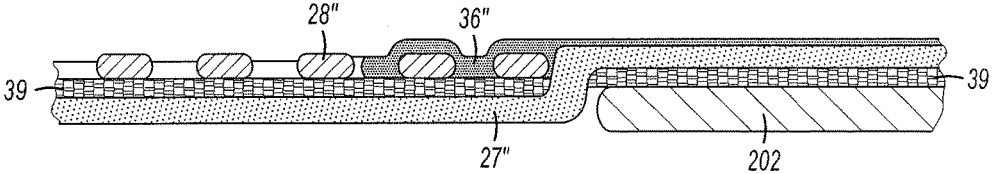

FIG. 6B

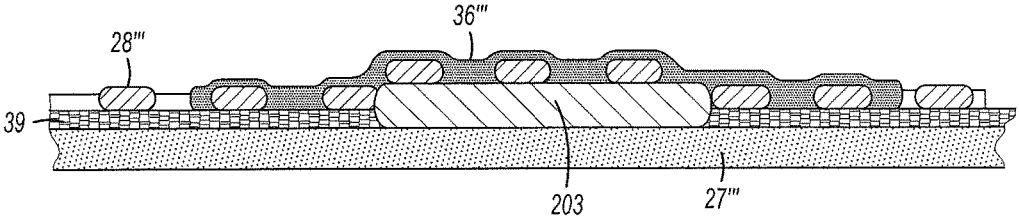

FIG. 6C

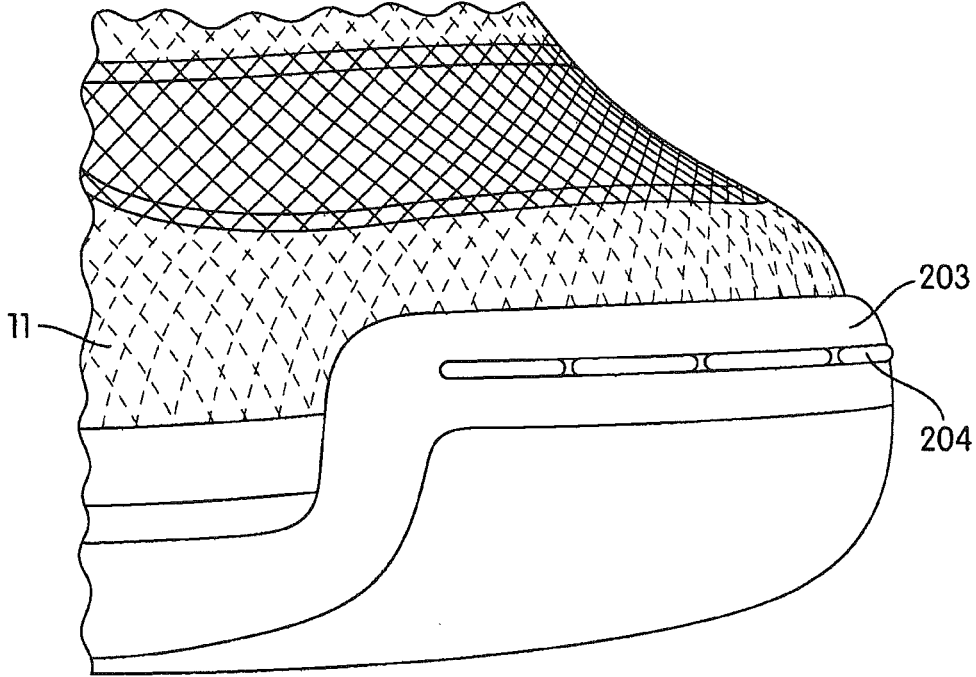

FIG. 7

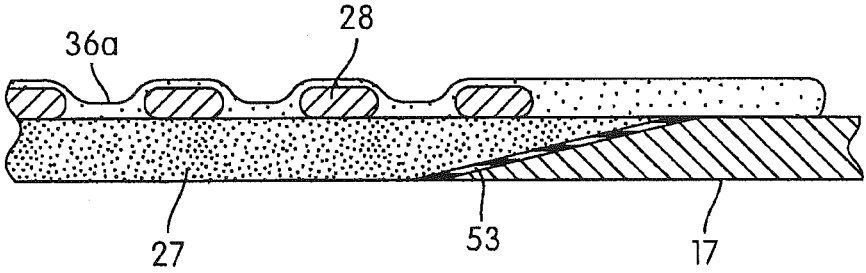

FIG. 8

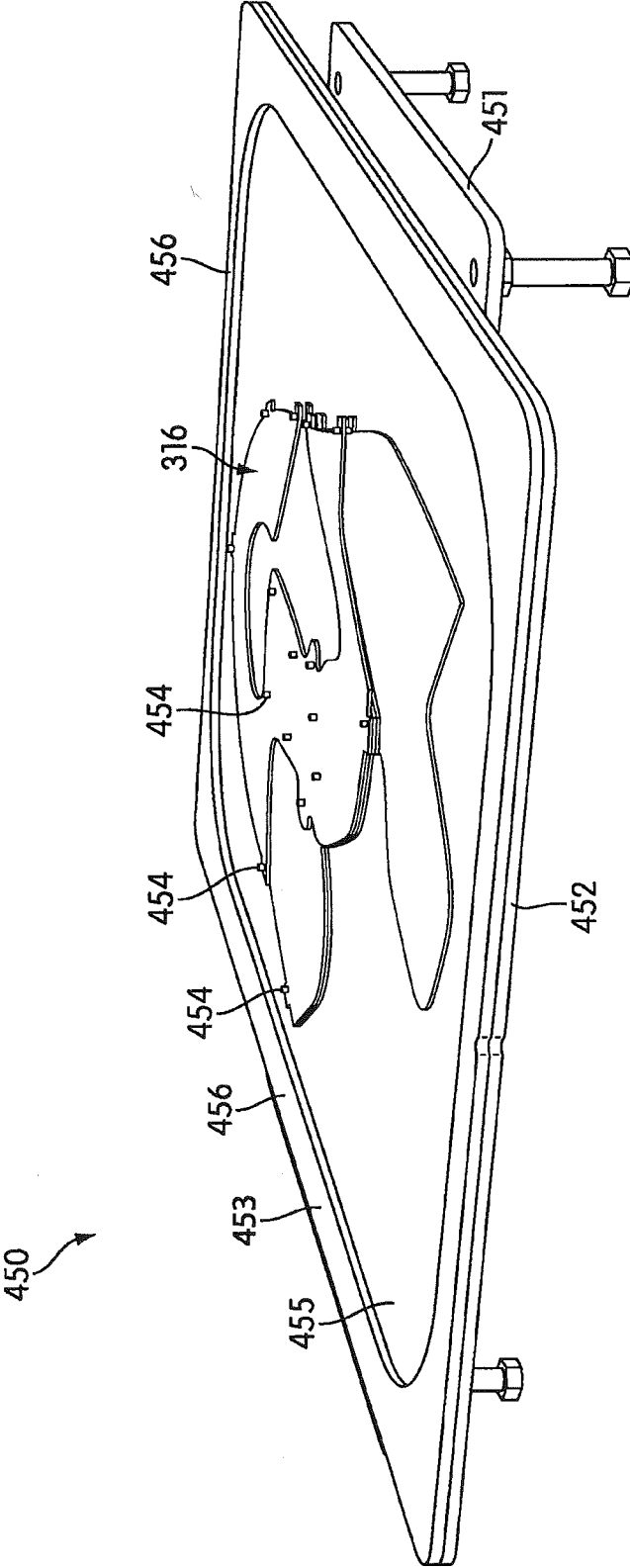

FIG. 9A



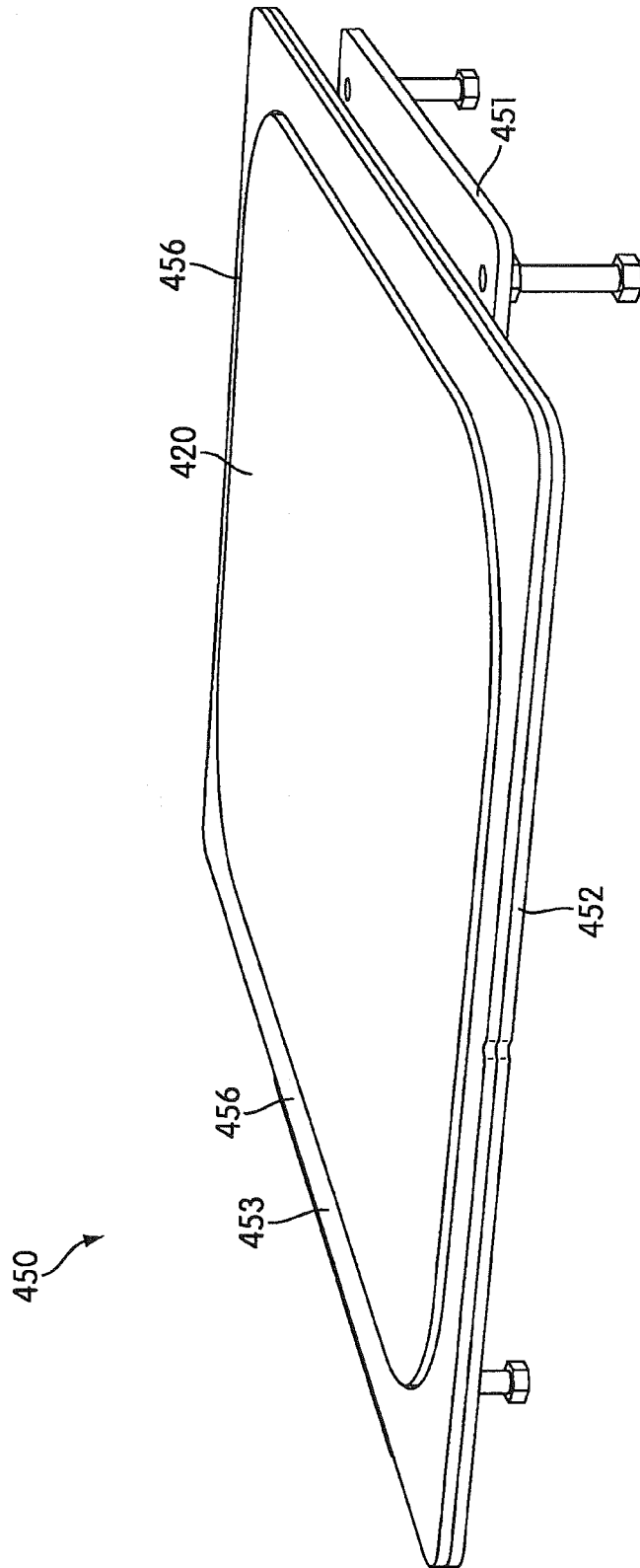

FIG. 9B

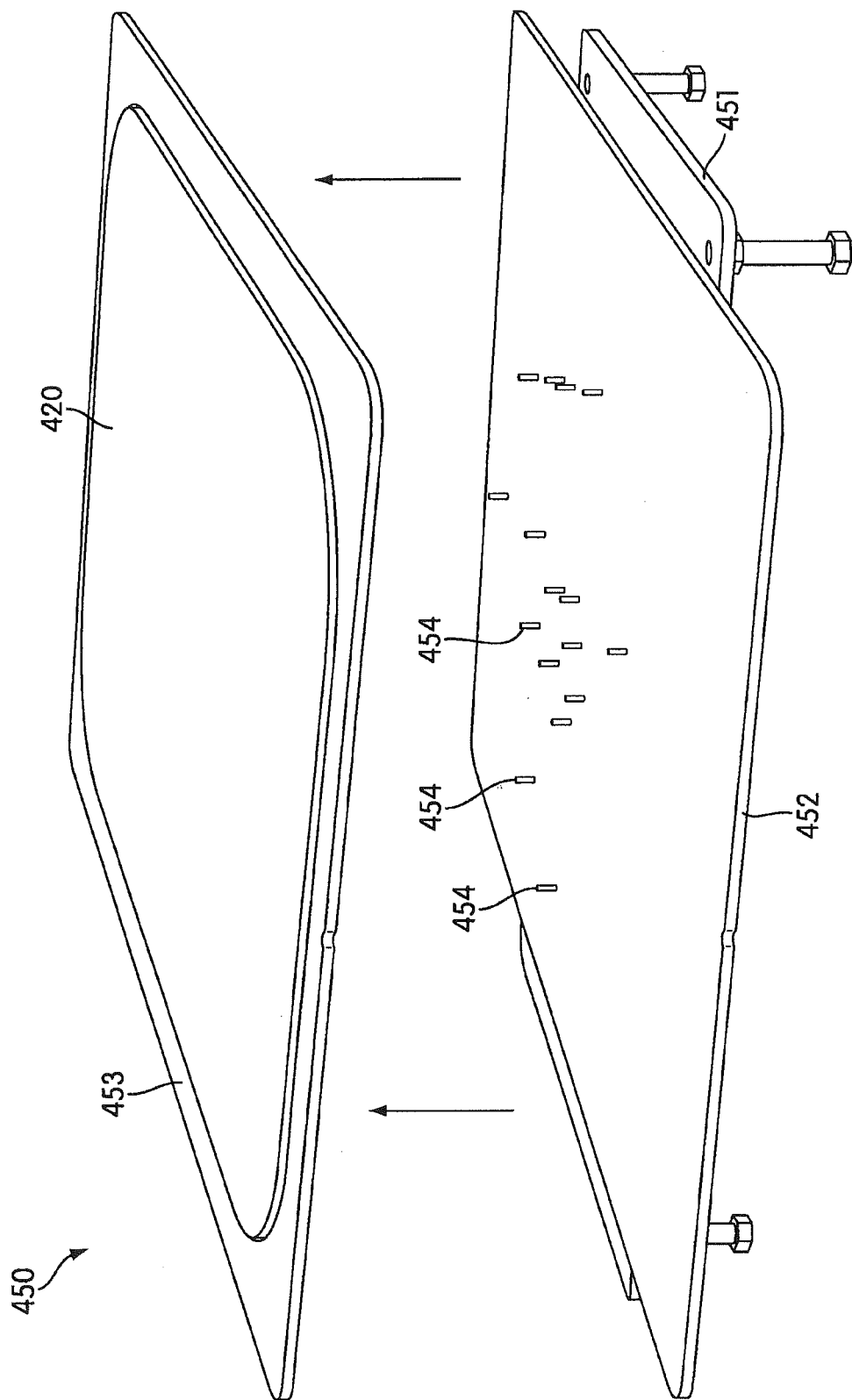

FIG. 9C

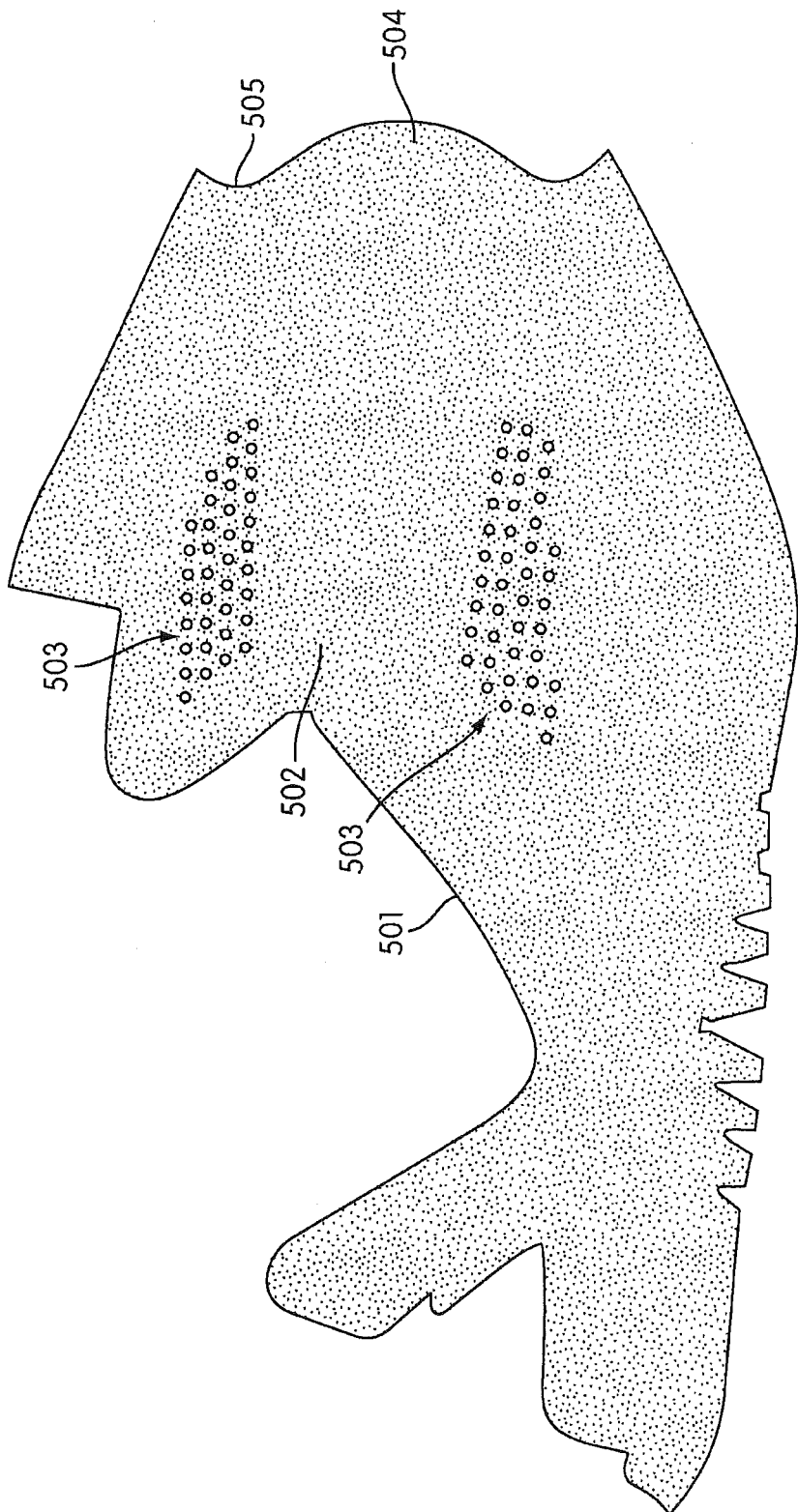

FIG. 10A

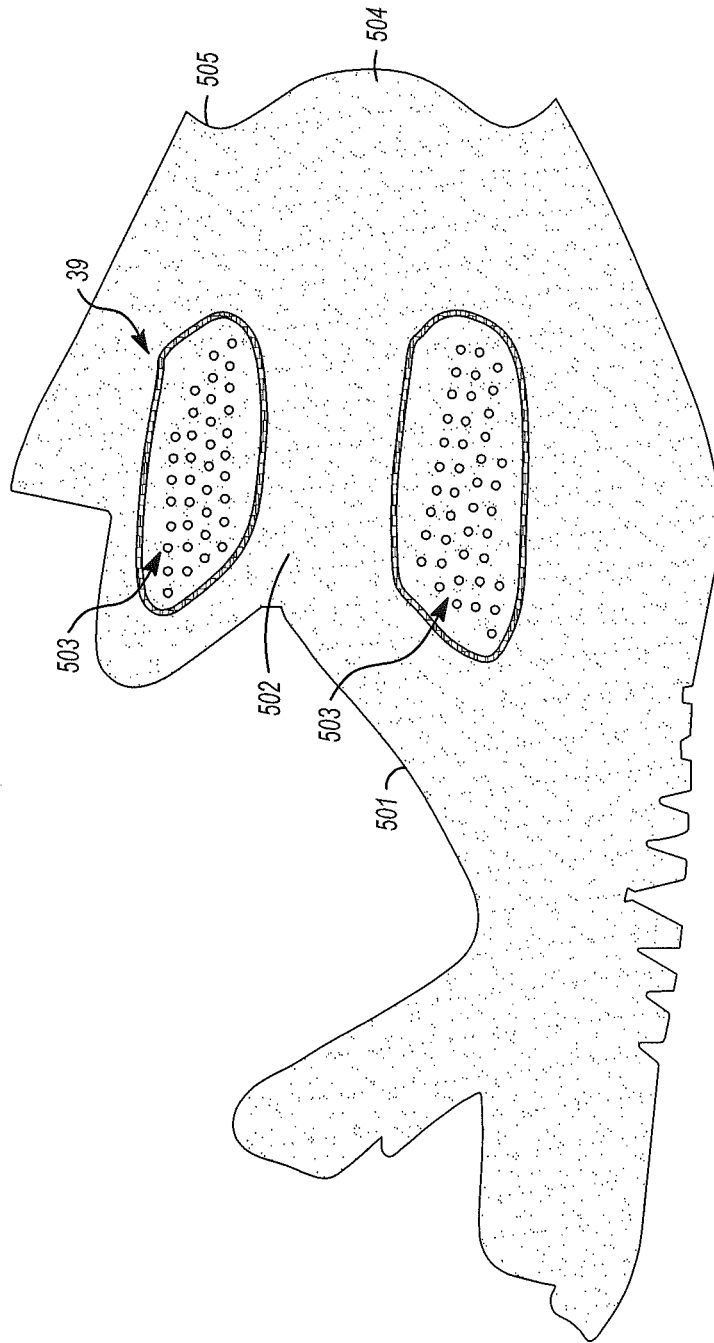

FIG. 10B

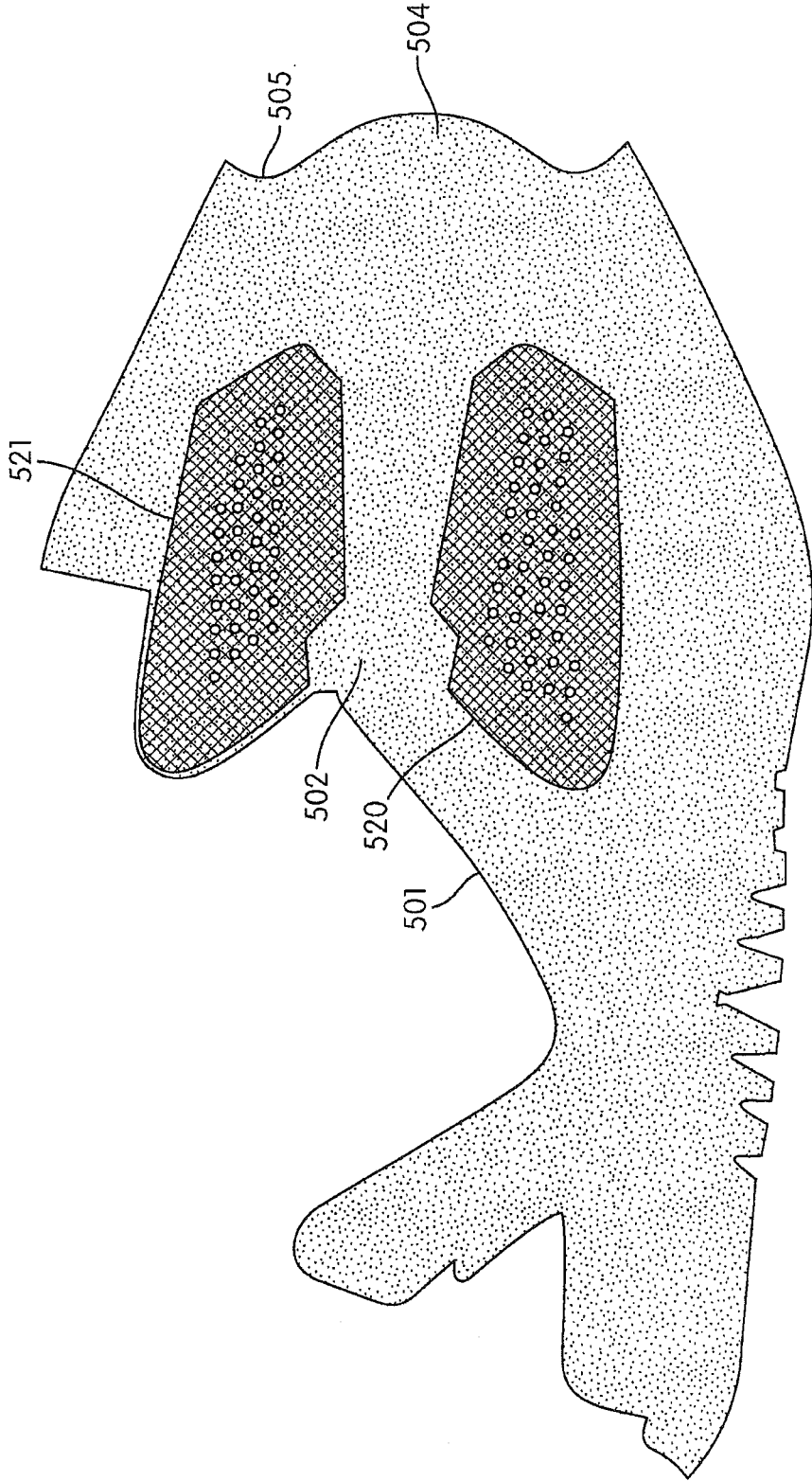

FIG. 10C

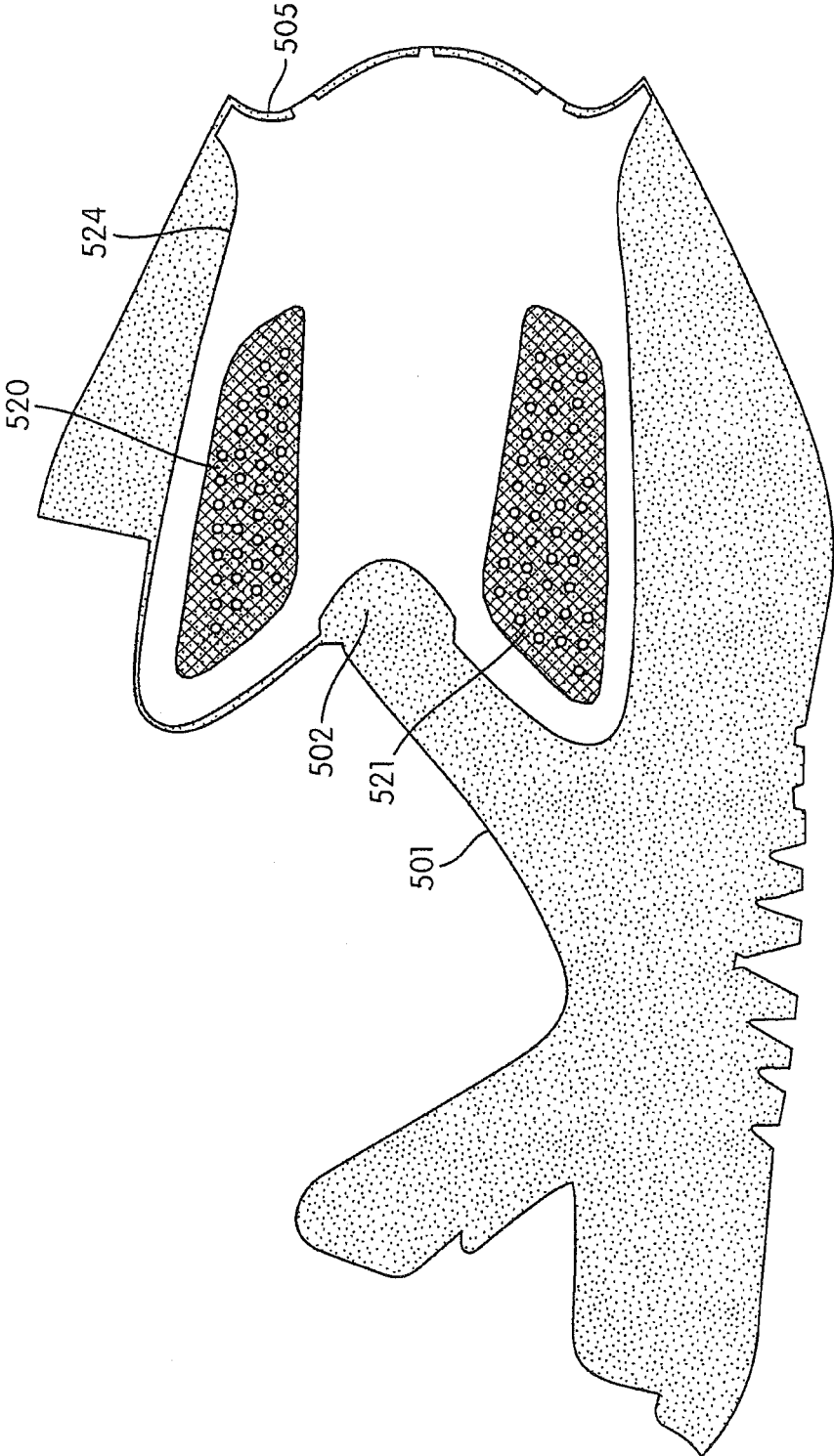

FIG. 10D

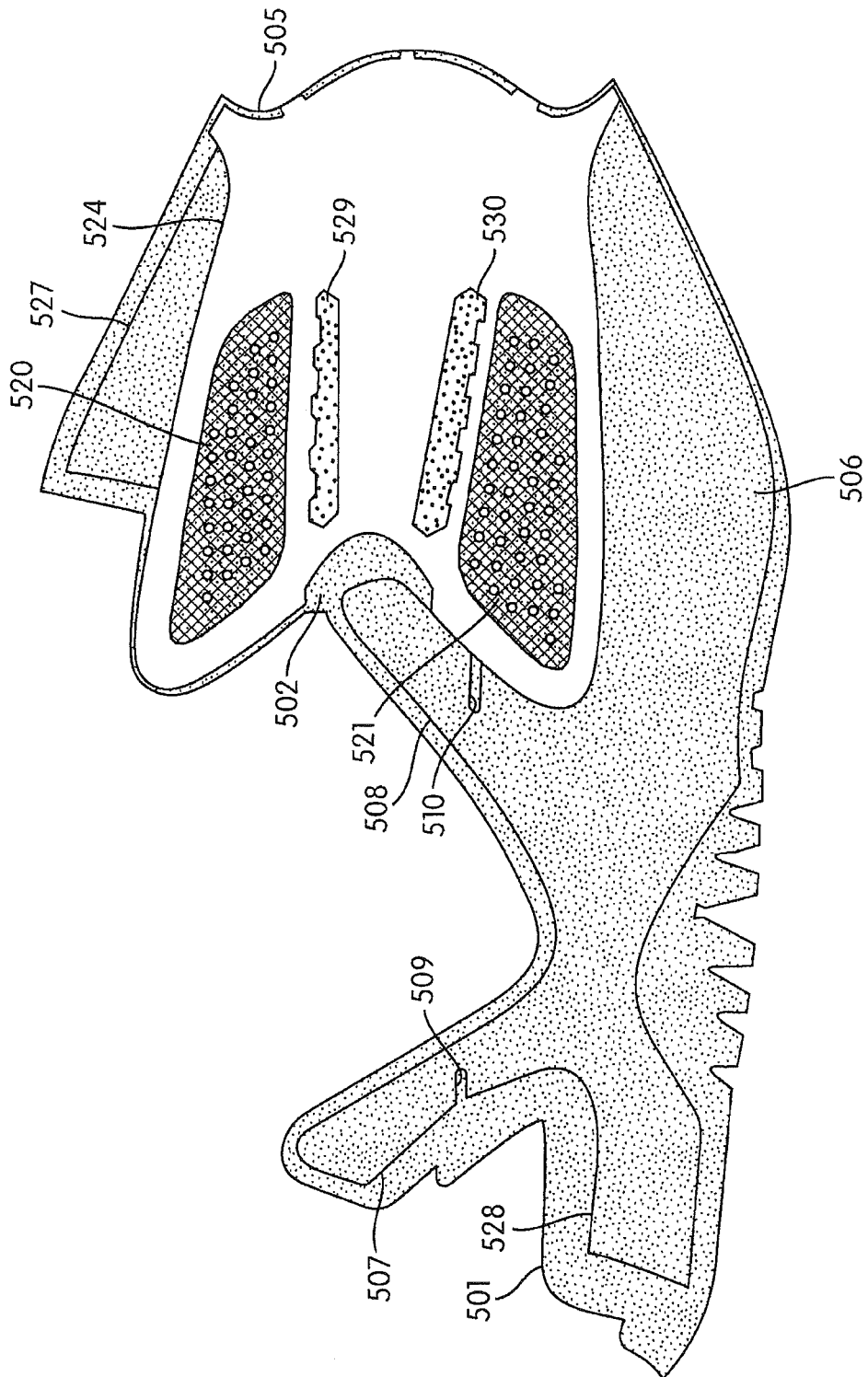

FIG. 10E

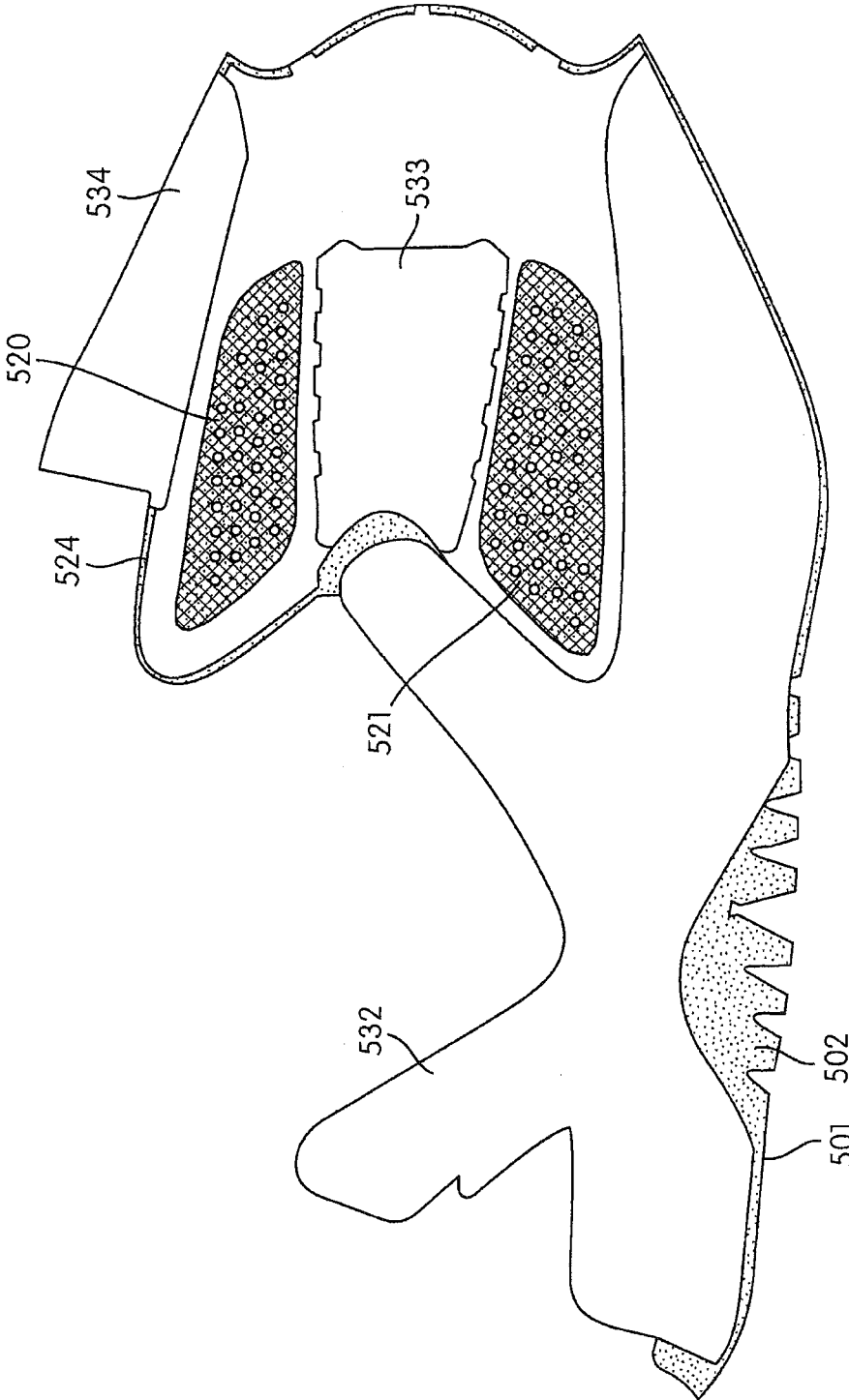

FIG. 10F



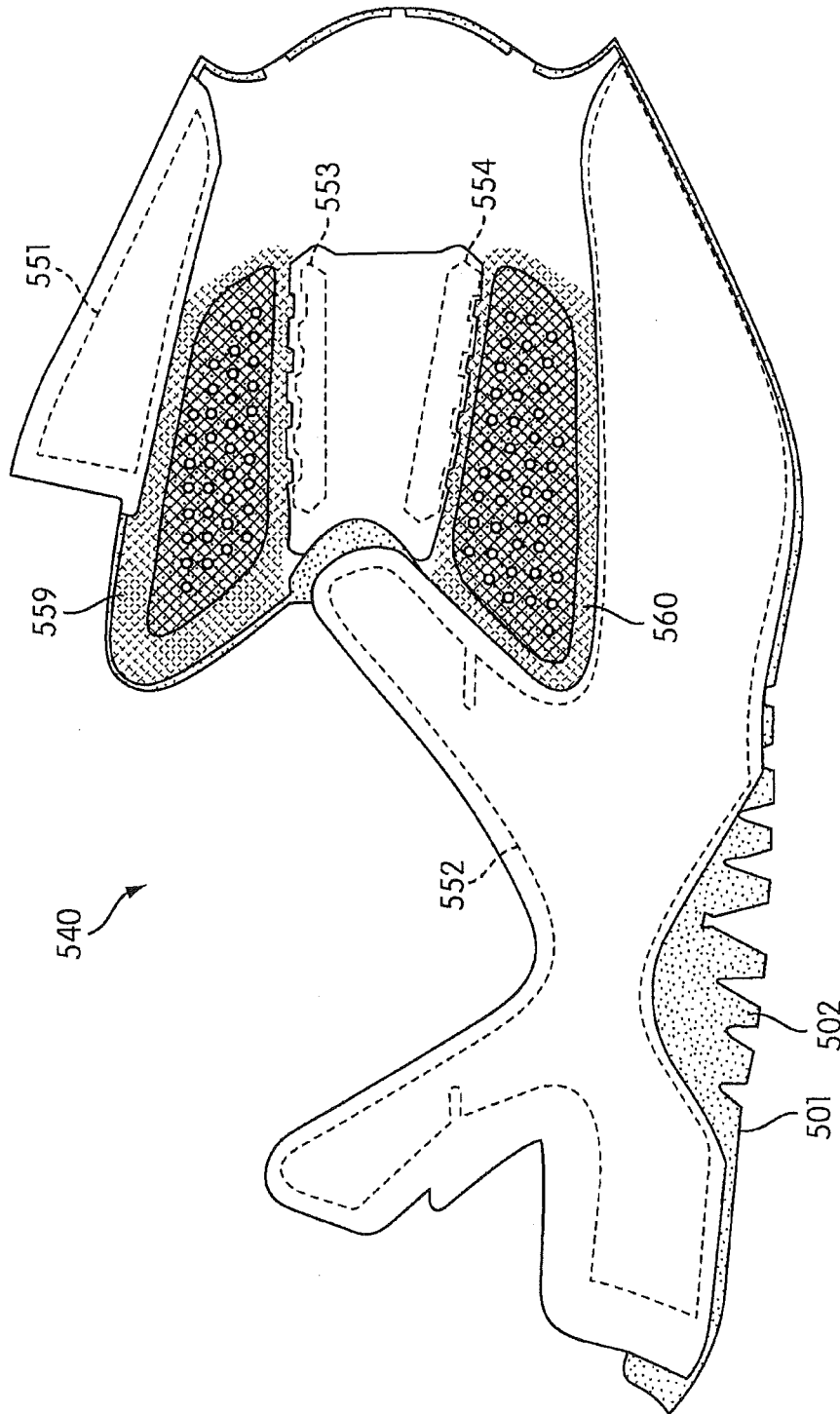

FIG. 11

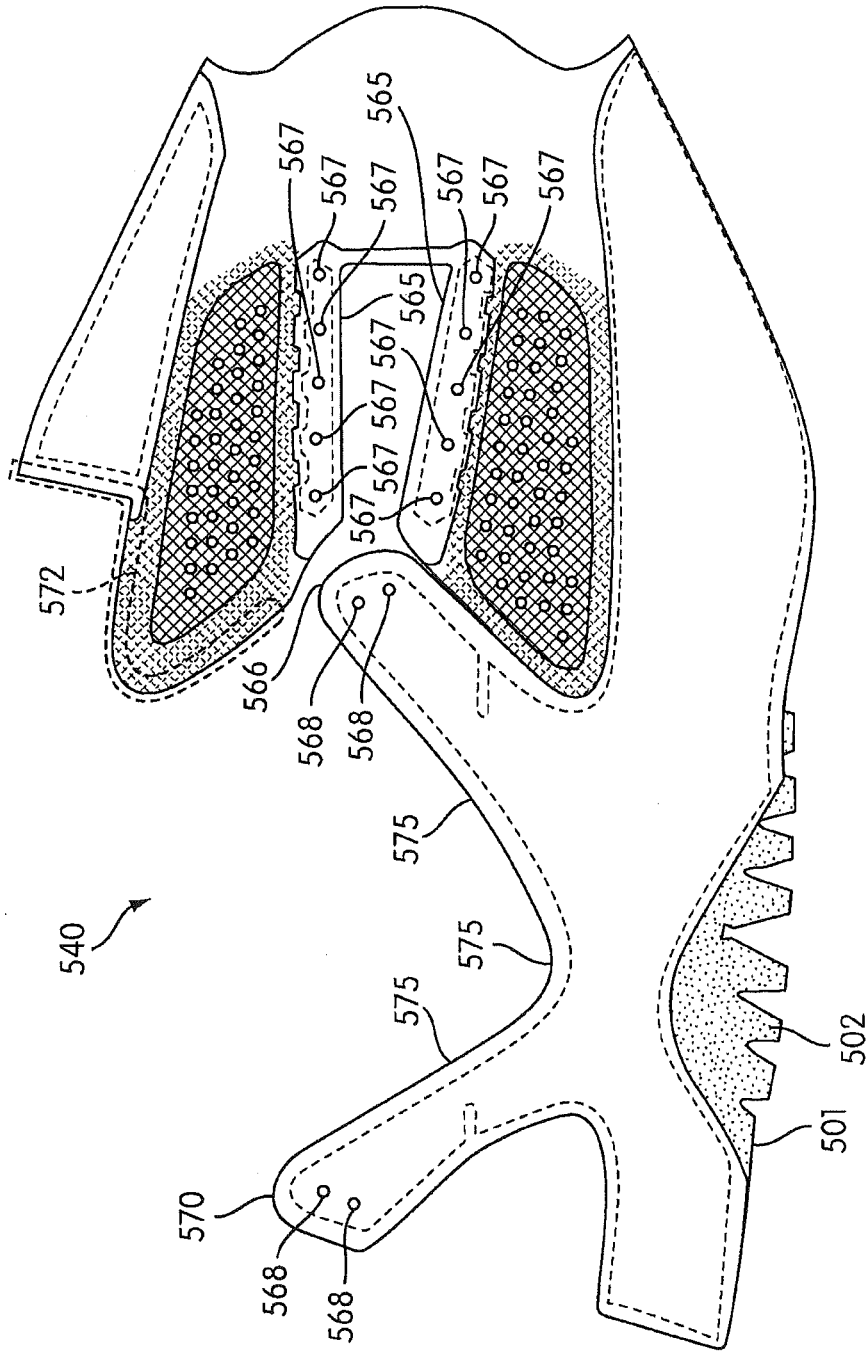

FIG. 12

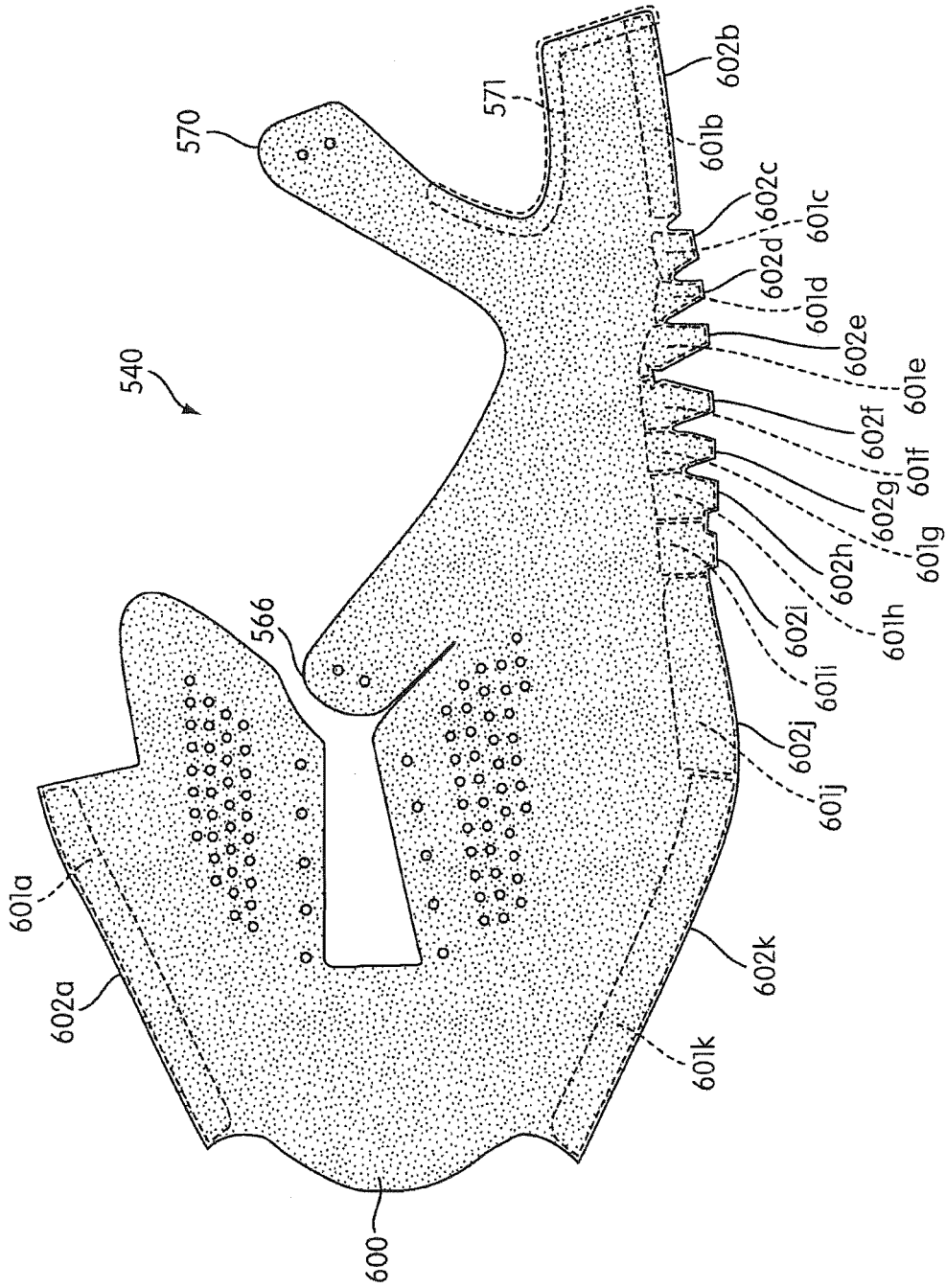

FIG. 13

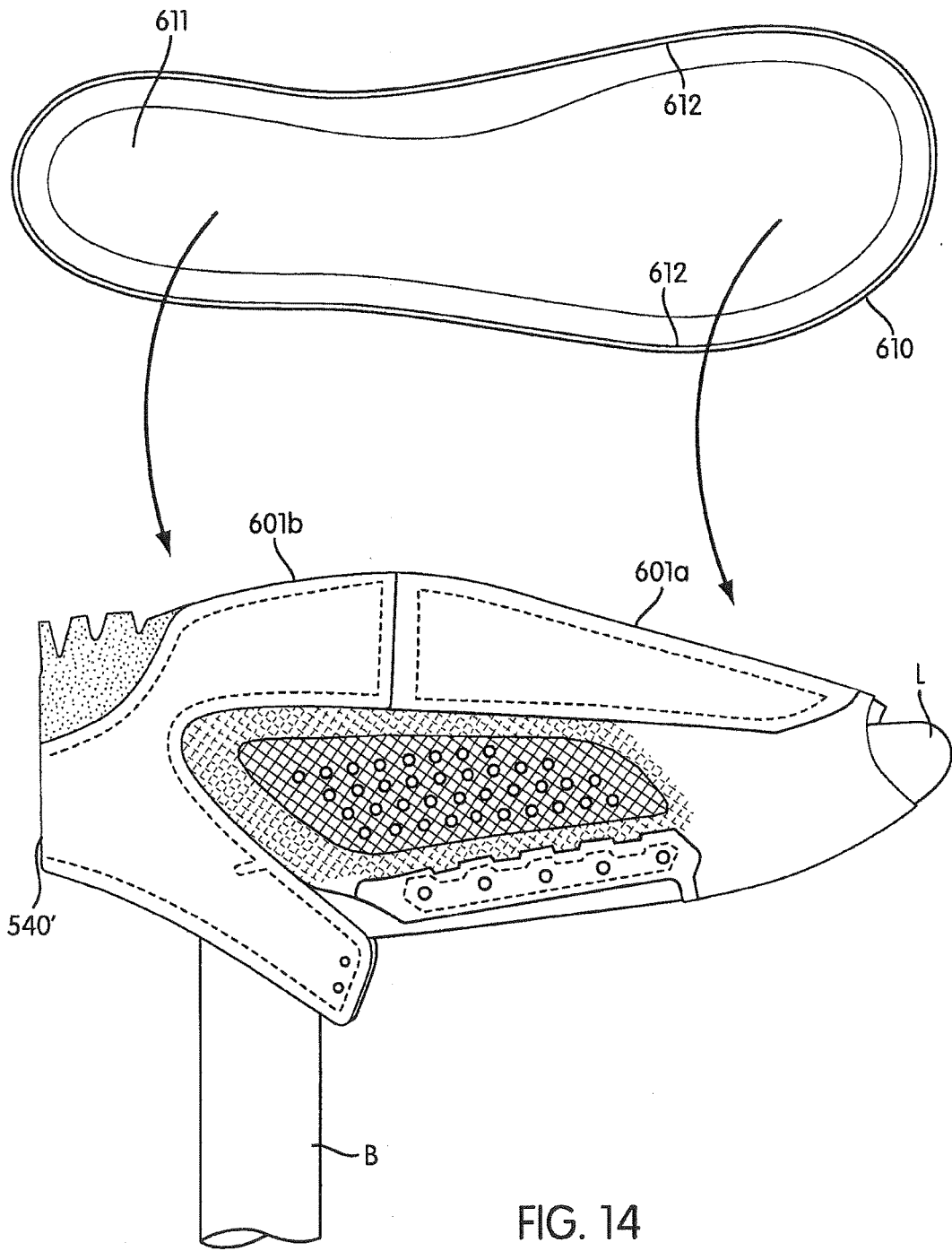

FIG. 14

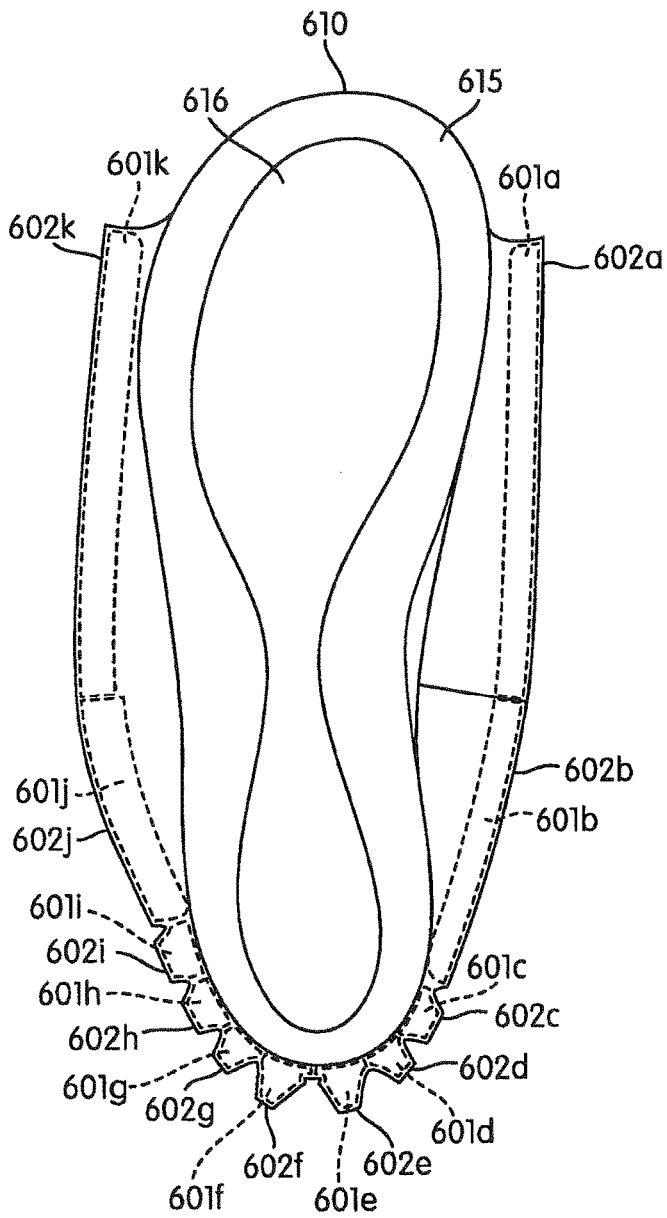

FIG. 15A

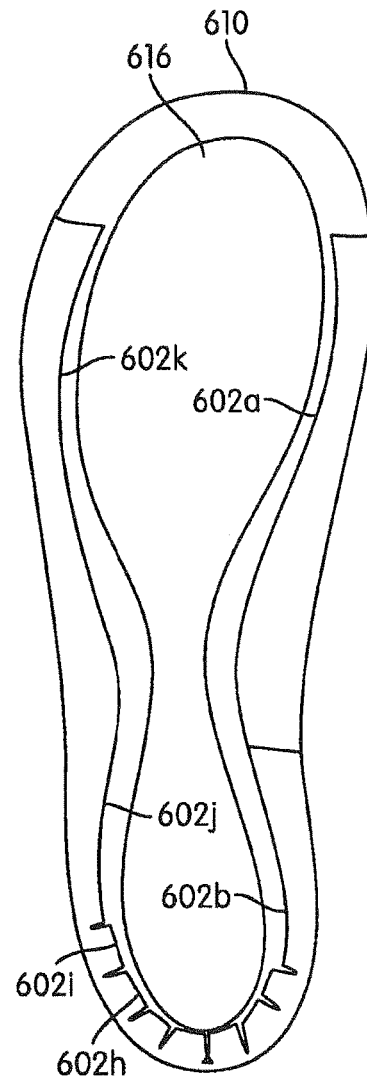

FIG. 15B

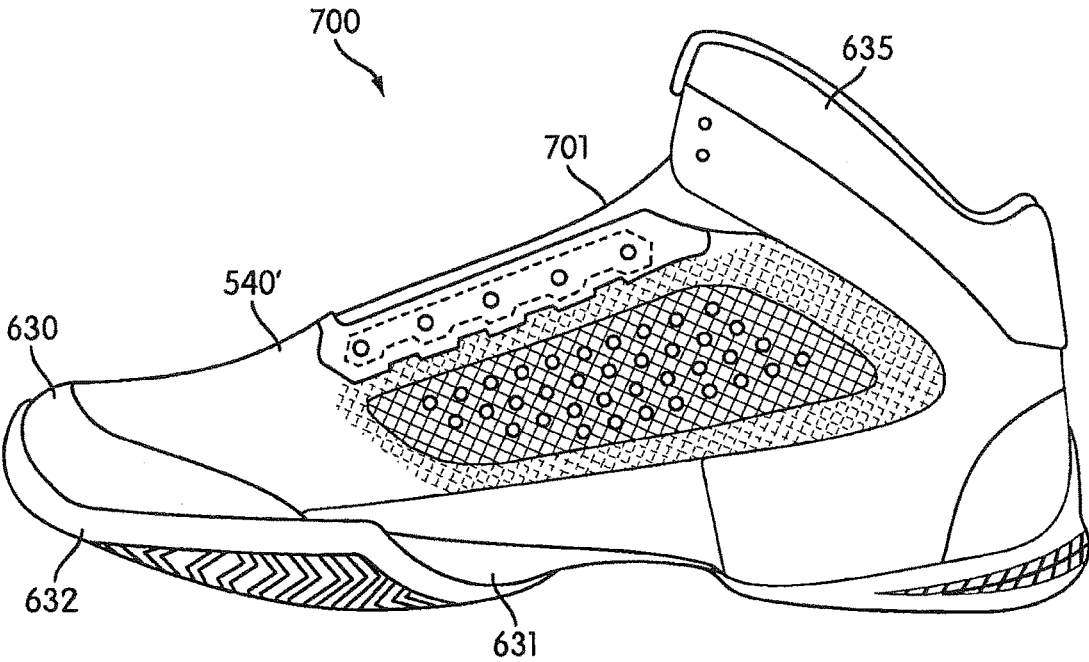

FIG. 16

## COMPOSITE UPPER FOR SHOE WITH SELECTIVELY DISPOSED BONDING AGENT

### CROSS-REFERENCE TO RELATED APPLICATIONS

[0001] This application is a divisional of U.S. application Ser. No. 15/075,372, filed Mar. 21, 2016, now allowed, which is a divisional of U.S. application Ser. No. 13/599,610, filed Aug. 30, 2012, now U.S. Pat. No. 9,320,312. The disclosures of each of these prior-filed applications are hereby incorporated by reference in their entireties.

### BACKGROUND

[0002] The design of many types of footwear is often driven by conflicting considerations. For example, it is normally desirable for an athletic shoe to have a construction that supports and protects a wearer's foot during a particular athletic endeavor. A second consideration, however, relates to the "breathability" of the shoe, which refers to the ease of air flow from the outside to a shoe interior. Good breathability can help relieve the effects of heat and perspiration that typically build up around a foot during sporting activities. Unfortunately, many materials that provide good support and foot protection can block air and moisture flow. Conversely, many materials that facilitate air and moisture flow provide little support or protection to the wearer's foot.

[0003] One solution is to fabricate a shoe in which some portions are formed from supportive/protective materials and some portions are formed from breathable materials. However, this can increase the complexity of the fabrication process and increase cost. Moreover, footwear design (including athletic footwear design) is also driven by aesthetics. A complex production process developed to fabricate a complex shoe can potentially limit a manufacturer's ability to vary that shoe's design to achieve different aesthetic effects. Yet a further consideration is the potential increase in waste generated from the cutting of various functional materials for use in the different portions. Fabrication processes and footwear articles that simultaneously address a number of these important considerations, relating to ease of manufacture and good final product characteristics in terms of support, breathability, and aesthetics, are described in U.S. Patent Appln. Publn. Nos. 2011/0088282 and 2011/0088285. These published U.S. patent applications are entirely incorporated herein by reference.

[0004] Efforts to improve such processes, particularly in terms of reducing the amount of waste or scrap materials generated, are ongoing in the art. The ability to utilize component materials more efficiently in the fabrication of composites, such as those used to manufacture footwear articles, can lead to significant cost savings. Such improvements can furthermore beneficially reduce the impact on the environment, as both the consumption and waste (disposal) requirements of the materials are diminished.

### SUMMARY

[0005] This Summary is provided to introduce a selection of concepts in a simplified form that are further described below in the Detailed Description. This Summary is not intended to identify key features or essential features of the invention.

[0006] Aspects of the invention are associated with the discovery of footwear fabrication methods having reduced

material consumption and/or waste requirements compared to conventional methods, as well as the footwear articles made by such methods. The fabrication methods and articles are characterized by the selective use of a bonding agent to bond various material panels, such substrate, mesh, and/or skin panels in the formation of a composite panel (e.g., a bonded mesh composite panel), which may in turn be used to provide a footwear upper and ultimately an article of footwear. In at least some examples, the bonding agent may be particularly applicable to fabrication processes utilizing a combination of heat and pressure for bonding or fusing material panels, each having a suitable composition, size, shape, and thickness, into the particular configuration of the footwear upper.

[0007] Selective application of the bonding agent, for example only at areas of overlap between material layers, may be achieved when the bonding agent is in the form of a solid powder, as opposed to being in the form of a conventional laminate film layer that is disposed indiscriminately over an entire material layer (e.g., substrate layer) surface. In addition to reducing material consumption and waste requirements, the selective application of bonding agent, in some areas but not others, may also enhance the overall breathability of the resulting footwear upper and consequently that of the footwear article produced from the upper. This enhancement, due to the decreased surface area of the upper upon which the bonding agent is disposed, can be achieved without a significant loss of support/protection, as the bonding agent generally contributes to such properties to only a limited extent.

[0008] Accordingly, embodiments of the invention are directed to an upper for an article of footwear. The upper has a bonded mesh composite panel comprising a substrate layer, a mesh layer overlapping the substrate layer in one or more mesh/substrate overlap areas but not overlapping the entire substrate layer, and a skin layer overlapping both the mesh and substrate layers in one or more skin/mesh/substrate overlap areas. The entire skin layer may overlap, or be positioned on, the mesh layer. Otherwise, the skin layer may partially overlap the mesh layer, with part of the skin layer overlapping the substrate layer in an area that does not have an intermediate mesh layer. A plurality of mesh layers and/or a plurality of skin layers may be used to provide structural and/or aesthetic effects in various areas of the upper, as desired. A bonding agent is selectively disposed (i) between the mesh and substrate layers, within one or more of the mesh/substrate overlap areas or (ii) between the mesh and skin layers, within one or more of the skin/mesh/substrate overlap areas.

[0009] Further embodiments of the invention are directed to articles of footwear comprising the bonded mesh composite panel as described above, in which the bonding agent is selectively disposed within one or more areas in which material layers overlap. In such articles of footwear, the substrate layer, mesh layer, and skin layer of the bonded mesh composite panel each have opposing inner and outer sides. The inner side of the substrate layer faces an interior of the article and the outer side of this layer is oriented away from the interior. The inner side of the mesh layer is oriented toward the outer side of the substrate layer within the mesh/substrate overlap areas. The inner side of the skin layer is oriented toward the mesh and substrate layers within the skin/mesh/substrate overlap areas. Such articles of footwear further may include a foam midsole, with portions of the

composite panel being bonded to the bottom surface of this foam midsole. According to particular embodiments, at least a portion of the outer side of the skin layer faces the exterior of the article of footwear.

**[0010]** Yet further embodiments of the invention are directed to methods of fabricating an upper for an article of footwear. Representative methods comprise selectively depositing a bonding agent, as a powder or a tackified powder, onto a substrate panel in one or more mesh/substrate overlap areas. A tackified powder may be obtained, for example, by preheating the powder or forming a paste from the powder. This preheating or paste formation may be performed before or after the powder is deposited onto the substrate panel. According to a specific embodiment, the bonding agent is selectively deposited as a tackified powder that is obtained by preheating the bonding agent, initially in powder form, on the substrate panel, prior to positioning one or more mesh panels onto the substrate panel. The tackified powder may, for example, be obtained by preheating the bonding agent using a laser, and a non-tackified (non-preheated) portion of the bonding agent may be removed, prior to positioning the one or more mesh panels. Representative fabrication methods further comprise positioning one or more mesh panels onto the substrate panel to provide the one or more mesh/substrate overlap areas having the bonding agent deposited between these panels. The methods additionally comprise compressing the substrate and mesh panels under bonding conditions suitable for forming a bonded mesh composite panel.

**[0011]** Optionally, the fabrication methods may also comprise positioning one or more skin panels onto the substrate and/or mesh panels. If the skin panel is positioned such that overlap with both the mesh and substrate panels occurs, then at least one skin/mesh/substrate overlap area is provided. Further optional embodiments comprise selectively depositing the bonding agent, as a powder or tackified powder, onto the mesh panel in one or more of such skin/mesh/substrate overlap areas. Methods according to alternative embodiments comprise selectively depositing the bonding agent, as a powder or tackified powder, in one or more of such skin/mesh/substrate overlap areas, even in the case where the bonding agent is not selectively deposited, as described above, onto a substrate panel in one or more mesh/substrate overlap areas (e.g., according to embodiments in which bonding between the substrate and mesh panels is achieved using a laminate film layer disposed on the outer side of the substrate panel and/or the inner side of the mesh panel).

**[0012]** The bonding agent, being selectively disposed, is therefore preferably not applied over the entire surface of the substrate panel, as in the case of a substrate panel having the bonding agent applied as a laminate film layer, for example pre-applied prior to the bonded mesh composite panel fabrication. The bonding agent may therefore be absent in certain areas or regions of the surfaces of the substrate and/or other material layers. For example, the bonding agent may be absent in areas where layers do not overlap. According to particular embodiments, therefore, the bonding agent is not located on the substrate layer in one or more areas that do not overlap the mesh layer. Otherwise, the bonding agent may be absent in areas of overlap where bonding between layers is not required (e.g., in a central region of the overlapping area), for example because of the presence of sufficient bonding agent in other areas of overlap (e.g., in

peripheral region of the overlapping area). According to some embodiments, the bonding agent is selectively deposited as a powder or tackified powder onto the mesh panel that is positioned onto the substrate panel to provide at least one mesh/substrate overlap area. In general, selective use of the bonding agent is associated with bonded mesh composite fabrication methods in which the areas of bonding between panels, and consequently the areas of deposition of the bonding agent, are determined based on the positioning or placement of these panels during fabrication.

**[0013]** Representative areas and regions where the bonding agent may be omitted, resulting in material cost savings and reduced waste, as described above, include those where no interlayer bonding is desired. The bonding agent may be absent, for example, from edge regions of the substrate panel that do not overlap with other panels, or otherwise in regions where no bonding should occur with other panels, even in the case of overlap. According to particular embodiments, the absence of bonding between overlapping layers of the bonded mesh composite, for example, allows additional components, such as foamed materials or other materials providing a 3-D enhancing effect, to be inserted or sealed between the non-bonded but overlapping areas of panels.

**[0014]** Further embodiments are directed to a shoe having an upper that includes a bonded mesh composite panel as described above, in which the bonding agent is selectively disposed within at least one area of overlap between material layers of the panel. The bonded mesh composite panel includes a substrate layer formed from synthetic leather or another material chosen to provide support and protection to the foot of a wearer, but that can include ventilation openings. The mesh composite panel further includes a mesh layer that is bonded to the substrate layer and spans (or overlaps) one or more of the ventilation openings. During fabrication, one or more panels of a thermoplastic polyurethane (TPU) or other desired material can also be included in certain regions so as to create skin layers that provide abrasion protection for the mesh layer and/or to achieve different aesthetic effects.

**[0015]** The bonded mesh composite panel for an upper, according to some embodiments, may be fabricated by first arranging panels of substrate, mesh, and skin layer materials into an assembly, such that the panels are arranged in locations corresponding to those in the bonded mesh composite, used in making the upper. The assembly may also include separate layers of hot melt bonding material interposed between the substrate, mesh and skin panels, and/or such a hot melt bonding material may be a component (e.g., a laminated film) of a substrate, mesh and/or skin layer panel. The bonding agent, which may have the same chemical composition (e.g., a polyurethane composition) as the hot melt bonding material or otherwise may have a different composition, is selectively deposited as a powder or tackified powder, within at least one area of overlap between the material panels, and preferably within at least one area of overlap between the mesh and substrate panels (i.e., a mesh/substrate overlap area).

**[0016]** In view of the use of the selectively deposited bonding agent, the substrate panel preferably does not include an additional layer (e.g., a laminated film layer) of bonding material (e.g., a TPU or other material that would normally cause bonding with the mesh layer under conditions of elevated temperature and pressure that are used to form the bonded mesh composite panel). Therefore, the



substrate panel preferably does not include a laminated layer of the same composition as the bonding agent or a layer of other hot melt bonding material. Preferably, additional layers having such bonding characteristics, but not formed from the selectively deposited bonding agent, are also not present as separate layers (e.g., as opposed to laminated layers) between the substrate and mesh panels. Such additional layers, whether laminated or separate, may, according to some embodiments, not be present in the assembly at all. However, as discussed above, the skin panel may in some cases include a TPU or other material that melts under the bonding conditions, to cause bonding between layers.

**[0017]** After the panels, with the bonding agent being selectively deposited as a powder or tackified powder between one or more areas or regions of overlap between panels, are arranged, the assembly is then pressed at an elevated temperature so as to melt the bonding agent, and optionally one or more skin panels, and bond the panels together. According to some embodiments, before the pressed assembly completely cools, it is pressed a second time in an unheated press. A heat-conductive compressible pad can be used in the pressing process to create a surface effect in the skin panels that reveals a pattern of an underlying mesh layer.

**[0018]** Yet further embodiments are directed the use of a bonded mesh composite panel as described above, to form a three-dimensional upper shell that includes extensions used for double-lasting and/or to otherwise provide a shelf to support foam padding. The foam padding may be, for example, a foam midsole. The extensions of the upper shell may be located in a lower portion of the shell and may be bonded to the foam midsole in a heel, midfoot and/or forefoot regions.

**[0019]** Still further embodiments are directed to layered material structures, including apparel items and apparel components (e.g., gloves, socks, hats, helmets, jackets and other outerwear such as skiwear, etc. and the layered material components of these items), as well as sporting goods items and sporting good components (e.g., footballs, basketballs, baseballs, volleyballs, golf balls, etc. and the layered material components of these items) comprising a bonded composite comprising a substrate layer (or layer of substrate material) and at least one additional layer (or layer of additional material), which may be the same material as the substrate layer or a different material from the substrate layer (such as a mesh layer), in which a bonding agent as described herein is selectively disposed between these two layers as described herein. Other embodiments are directed to methods of fabricating such layered material structures, described above, comprising selectively depositing a bonding agent, as a powder or a tackified powder as described herein, onto a substrate panel in one or more panel overlap areas (i.e., areas of overlap between the substrate panel and at least one additional panel, which may be the same material as the substrate panel or a different material from the substrate panel, such as a mesh panel). According to a specific embodiment, the bonding agent is selectively deposited as a tackified powder that is obtained by preheating the bonding agent, initially in powder form, on the substrate panel, prior to positioning the additional panel onto the substrate panel. The tackified powder may, for example, be obtained by preheating the bonding agent using a laser, and a non-tackified (non-preheated) portion of the bonding agent may be removed, prior to positioning the additional panel.

Representative fabrication methods further comprise positioning the additional panel onto the substrate panel to provide the one or more panel overlap areas having the bonding agent deposited between these panels. The methods additionally comprise compressing the substrate and mesh panels under bonding conditions suitable for forming the layered material structure.

#### BRIEF DESCRIPTION OF THE DRAWINGS

**[0020]** Some embodiments are illustrated by way of example, and not by way of limitation, in the figures of the accompanying drawings and in which like reference numerals refer to similar elements.

**[0021]** FIGS. 1A and 1B are, respectively, lateral and medial views of a shoe according to some embodiments.

**[0022]** FIG. 1C is an enlarged view of the area indicated in FIG. 1A showing an aspect of the mesh composite in the embodiment of FIGS. 1A and 1B.

**[0023]** FIG. 2 is a partially schematic diagram showing creation of a multilayer mesh composite according to some embodiments.

**[0024]** FIG. 3 is a partially schematic cross-sectional view from the location indicated in FIG. 1A showing the structure of a mesh composite according to some embodiments.

**[0025]** FIGS. 4A1 through 4L show operations in a process, according to at least some embodiments, to fabricate a unibody upper panel for the shoe of FIGS. 1A and 1B.

**[0026]** FIGS. 5A through 5G show additional operations in a process, according to at least some embodiments, to fabricate an upper for the shoe of FIGS. 1A and 1B.

**[0027]** FIGS. 6A through 6C show examples of composite upper portions, according to some additional embodiments, that include an additional layer for reinforcement, support and/or padding.

**[0028]** FIG. 7 shows a toe cap extension in a shoe according to some embodiments.

**[0029]** FIG. 8 shows a layer of skin material used to reinforce a transition from a mesh composite portion of a shell to another portion according to some embodiments.

**[0030]** FIGS. 9A through 9C show an assembly jig that can be used in fabrication methods according to some embodiments.

**[0031]** FIGS. 10A through 10F show assembly of panel elements for a unibody upper shell according to another embodiment.

**[0032]** FIG. 11 shows a bonded composite panel formed from the panels assembled in FIGS. 10A through 10F.

**[0033]** FIG. 12 shows the bonded composite panel of FIG. 11 after trimming.

**[0034]** FIG. 13 shows an inner face of the trimmed, bonded composite panel of FIG. 12.

**[0035]** FIG. 14 shows a three-dimensional upper shell formed from the trimmed, bonded composite panel of FIG. 12 and placed onto a last.

**[0036]** FIGS. 15A and 15B show attachment of the three-dimensional upper shell from FIG. 14 to a foam midsole.

**[0037]** FIG. 16 shows a completed shoe that includes the upper shell and attached foam midsole from FIG. 15B.

#### DETAILED DESCRIPTION

**[0038]** At least some embodiments include an athletic shoe or other type of footwear in which an upper has a panel formed from a bonded mesh composite, in which a bonding

agent, advantageously, is selectively disposed between elements of the bonded mesh composite, for example between mesh and substrate material layers or panels. The bonding agent may be disposed: (i) within one or more of the mesh/substrate overlap areas, (ii) within one or more of the mesh/skin overlap areas, and/or (iii) within one or more of the skin/mesh/substrate overlap areas. Compared to conventional uppers having a bonding agent laminated over an entire material layer surface, the requirement for the amount of bonding agent utilized in such embodiments of the invention may be reduced. For example, because the bonding agent is selectively disposed (or selectively deposited during fabrication), it is not present in at least one area of overlap in the material layers used to form the bonded mesh composite. Therefore, according to some embodiments, the bonding agent is not present on the substrate layer in one or more areas that do not overlap the mesh layer. Otherwise, according to other embodiments, the bonding agent is not present on the skin layer in one or more areas that do not overlap the mesh layer.

**[0039]** The mesh composite includes an inner substrate layer that provides support and protection in appropriate regions based on activities for which the shoe is intended. The substrate layer can also include one or more openings for ventilation, weight reduction or other purposes. The mesh composite further includes a mesh layer that is bonded to the substrate layer and located on the outer side of the substrate in the finished shoe. This construction offers several advantages. For example, the mesh can reinforce the substrate and help retain individual portions of the substrate in a desired arrangement, thereby permitting larger ventilation holes in the substrate. Moreover, covering those ventilation holes and surrounding substrate regions with a mesh can avoid edges that might separate as the shoe wears. A “skin” layer may cover the mesh layer in one or more areas to provide additional durability and/or for decorative purposes. In some embodiments, substantially all of the upper is formed from a mesh composite panel that extends around the heel counter region. In other embodiments, the upper may have a mesh composite panel in a front portion that is bonded or otherwise attached to a separate panel that forms a rear portion of the upper.

#### Definitions

**[0040]** To assist and clarify subsequent description of various embodiments, various terms are defined herein. Unless otherwise indicated, the following definitions apply throughout this specification (including the claims). The “interior” of a shoe refers to space that is occupied by a wearer’s foot when the shoe is worn. The “inner side” of a panel or other shoe element refers to the face of that panel or element that is (or will be) oriented toward the shoe interior in a completed shoe. The “outer side” of an element refers to the face of that element that is (or will be) oriented away from the shoe interior in the completed shoe. In some cases, the inner side of an element may have other elements between that inner side and the interior in the completed shoe. Similarly, an outer side of an element may have other elements between that outer side and the space external to the completed shoe.

**[0041]** A “bonded” composite element (e.g., a bonded mesh composite panel) is an element that includes substituent elements (e.g., panels of textile or other materials) that are bonded to one another. “Bonding” includes chemical

adhesion through the use of glue or other adhesives, through melting and subsequent solidification of a bonding agent, and/or through melting and subsequent solidification of a substituent element, such as a skin panel. “Bonding” excludes stitching, stapling or similar types of mechanical attachment. Although a bonded composite element may include stitching or other types of mechanical attachment (e.g., to attach the bonded composite element to another element, to shape the bonded composite element, or to provide decorative features in the bonded composite element), the bonded composite element does not rely on that stitching or other mechanical attachment to structurally connect the substituent elements of the bonded composite element.

**[0042]** The bonding agent, according to embodiments described herein, is “selectively disposed” between overlapping substituent elements (e.g., material panels) to provide bonding in at least a portion of the overlap area. In the case of methods for fabricating such bonded composite elements, the bonding agent is “selectively deposited,” as a powder or tackified powder, between overlapping substituent elements that are positioned and compressed to activate the bonding agent. Having a bonding agent that is selectively disposed or selectively deposited is distinguishable from the situation in which the bonding agent is applied entirely across a substituent element, for example where the bonding agent is pre-applied as a laminate film onto a substrate panel or a mesh panel. In the case of a laminated film of bonding agent being pre-applied onto such a substituent element, portions of the laminate film that are not present between overlapping material layers, as well as portions that are initially cut away from the substrate raw material in forming the substrate panel, represent losses that must be properly disposed of or recycled. Although a number of exemplary embodiments herein are directed to a bonding agent being “selectively disposed” or “selectively deposited” between a substrate layer or panel and a mesh layer or panel, any other type of at least one additional layer or panel (i.e., in addition to the substrate layer or panel), whether of the same material as, or of a different material from, the substrate panel, can be used in place of the mesh layer or panel.

**[0043]** An “overlapping area” includes the entire area of overlap between substituent elements (e.g., material panels). A “region” may also refer to an entire area of overlap, or otherwise only a portion of the area. A “region” may also refer to other specific areas of the upper, which may or may not be in areas of overlap between two or more panels or layers.

**[0044]** Certain regions of an upper are defined by reference to the anatomical structures of a human foot wearing a shoe that is properly sized for that foot. One or more of the below-defined regions may overlap. The “forefoot” region of an upper is the portion of the upper that will generally cover the metatarsal and phalangeal bones of the wearer’s foot, and which will extend beyond the wearer’s toes to the frontmost portion of the upper. The “midfoot” region of an upper is the portion of the upper that will generally cover the cuboid, navicular, medial cuneiform, intermediate cuneiform and lateral cuneiform bones of the wearer’s foot. The “hindfoot” region of an upper extends from the midfoot region to the rearmost portion of the upper and covers the wearer heel. The hindfoot region covers the sides of the

calcaneus bone of a wearer and may, depending on a particular shoe configuration, cover some or all of the wearer's talus bone (ankle).

**[0045]** The top forefoot and top midfoot regions of an upper will generally cover the upper surfaces of a wearer's forefoot and midfoot bones described above. The toe of the upper is the portion that will generally cover the tops and fronts of the toes and that extends from the top forefoot region to the lowest edge of the upper in the direction of the sole. The lateral forefoot region extends between the top forefoot and the lowest edge of the upper in the direction of the sole and between the toe and lateral midfoot regions. The lateral midfoot region extends between the top midfoot region and the lowest edge of the upper in the direction of the sole and between the lateral forefoot and hindfoot regions. In a similar manner, the medial forefoot region extends between the top forefoot region and the lowest edge of the upper in the direction of the sole and between the toe and medial midfoot regions, the medial midfoot region extends between the top midfoot region and the lowest edge of the upper in the direction of the sole and between the medial forefoot and hindfoot regions. The topfoot region includes the top forefoot and top midfoot regions. The lateral side region includes the lateral forefoot and lateral midfoot regions. The medial side region includes the medial forefoot and medial midfoot regions.

Shoe with Mesh Composite Upper Panel

**[0046]** FIG. 1A is lateral view of a shoe 10 according to at least some embodiments. FIG. 1B is a medial view of shoe 10. In the embodiment of FIGS. 1A and 1B, the upper 11 of shoe 10 includes a bonded mesh composite panel 16 and a foxing panel 17. Additional details of mesh composite panel 16 and its construction, as well the attachment of mesh composite panel 16 to foxing panel 17, are provided below in connection with FIGS. 1C and 4A1-4L.

**[0047]** In shoe 10, mesh composite panel 16 generally covers the toe region, the top, lateral and medial forefoot regions, the top, lateral and medial midfoot regions, and portions of the hindfoot region. The foxing panel 17 at the rear portion of the upper 11 covers the remainder of the hindfoot region. As explained in more detail below, shoe 10 of FIGS. 1A and 1B is merely one example of footwear according to various embodiments. In other embodiments, a mesh composite front portion of an upper panel may be joined to a non-mesh-composite rear portion at different locations and/or along joints having different configurations. In still other embodiments (e.g., an embodiment such as is described in connection with FIGS. 10A-16), an entire upper shell is formed from a mesh composite that includes a contiguous substrate element that completely surrounds a wearer foot in a completed shoe

**[0048]** FIG. 1C is an enlarged view of the area indicated in FIG. 1A showing the details of a portion of mesh composite panel 16 of shoe 10. A mesh layer 28 of mesh material is bonded to a substrate layer 27 of substrate material in a manner described below. According to some embodiments, mesh layer 28 can cover, or be bonded to, all or substantially all of substrate layer 27. For illustrative purposes, a portion of the mesh layer 28 below broken line 30 has been removed in FIG. 1C to further expose substrate layer 27. For convenience and to avoid obscuring the drawings with excessive detail, the mesh material of mesh layer 28 (and of mesh layers in other embodiments) is shown in the various drawing figures as a simple and relatively

course grid pattern with a diagonal orientation. Actual materials used for mesh layer 28 (or for mesh layers in other embodiments), examples of which are provided below, may have a more complex and/or finer weave structure. A skin panel 36a of skin material is in turn bonded to mesh layer 28 and to substrate layer 27 to form a skin layer. As is also discussed in more detail below, the layer of skin material conforms to the mesh material of mesh layer 28 so as to reveal a surface texture having a contour corresponding to that of the mesh material. For simplicity, a view of this conformance perpendicular to a skin layer is represented in the drawings as a partially broken version of the grid pattern used for mesh layer 28.

**[0049]** Returning to FIGS. 1A and 1B, the substrate material of substrate layer 27 extends across all of mesh composite panel 16 except for a tongue opening 26, lateral ventilation holes 31 and 32, medial ventilation hole 33, and top forefoot ventilation hole 34. Other embodiments have an inner substrate material layer that includes more or fewer holes, and/or holes of different shapes and/or in different locations. As is further explained below in connection with FIGS. 4A1-4L, the mesh material of mesh layer 28 is bonded to substrate layer 27 over most, but not all, of panel 16 in the embodiment of FIGS. 1A and 1B. According to embodiments of the invention, a bonding agent is selectively disposed between mesh layer 28 and substrate layer 27, within one or more areas, such as region 112 (FIGS. 4E1-4E4), in which these layers overlap (i.e., within one or more mesh/substrate overlap areas). It is possible that the bonding agent is therefore not disposed on substrate layer 27 in one or more areas or regions, such as region 110 (FIG. 4F) that do not overlap mesh layer 28 in the resulting bonded mesh composite panel. Often, the bonding agent is selectively disposed between the mesh layer 28 and substrate layer 27, within all of the mesh/substrate overlap areas, or at least within selected regions within all of these overlap areas.

**[0050]** Representative methods according to the invention therefore comprise selectively depositing a bonding agent, as a powder or tackified powder, onto a substrate panel in one or more mesh/substrate overlap areas. The bonding agent is preferably not applied over the entire surface of the substrate panel, for example in edge regions that do not overlap with other panels, or otherwise in regions where no bonding with other panels, even in the case of overlap, is desired. By selectively depositing the bonding agent in one or more mesh/substrate overlap areas, the bonding agent may be used more judiciously, compared to the case of having a hot melt bonding material being pre-applied to the entire substrate layer 27, for example as a laminate film layer. In using such laminated substrate layers, portions of hot melt bonding material, namely those portions not present in areas or regions that do not overlap mesh layer, are not effectively utilized for mesh/substrate bonding and are therefore wasted. Further waste of the hot melt bonding material, when pre-applied to the substrate layer, results from initially cutting the substrate raw material in the shape required for substrate layer 27, for example the shape shown in FIG. 4C. Often, for example, the substrate panel, formed from substrate layer, is die cut, prior to arranging it with other material layers that are bonded to form upper 11. The cutting of the substrate raw material results in waste of unused parts of the substrate, including waste of any hot melt bonding material or other material that may be present in the substrate as a laminated layer. Selectively depositing the bond-

ing agent can also enhance the overall breathability of the bonded mesh composite, as the bonding agent is used only in selected areas or regions.

**[0051]** The embodiment of FIGS. 1A and 1B also includes skin layers formed by panels 36a, 36b, 36c and 36d. The skin material of panels 36a and 36c similarly conforms to the mesh material of layer 28 so as to reveal a surface texture corresponding to the mesh. The mesh material underlying panel 36d is compressed so as to provide a smooth texture on the external surface of panel 36d, as is also described more fully below.

**[0052]** Because mesh layer 28 is directly bonded to substrate layer 27, the combined strength of the mesh and substrate materials obviates the need for another material on the outside surface of upper 11 to provide tensile strength. This permits upper 11 to be much lighter than is possible using various conventional shoe construction techniques. Representative methods according to the invention therefore comprise positioning one or more mesh panels onto the substrate panel to provide the one or more mesh/substrate overlap areas having the bonding agent disposed therebetween. Panels of skin material (which are relatively lightweight) can be included in certain areas of an upper where abrasion protection is helpful. Thus, methods according to the invention may further comprise positioning one or more skin panels onto the substrate and mesh panels to provide one or more skin/mesh/substrate overlap areas. As discussed herein, it is not necessary for a skin panel to overlap both mesh and substrate panels in all areas where the skin panel is positioned.

**[0053]** Ventilation holes 31, 32, 33 and 34 in substrate layer 27 allow air to flow through perforations of the mesh material of mesh layer 28. This flow helps to cool and dry the foot of a wearer of shoe 10. In some embodiments, there are no additional material layers separating substrate layer 27 and the foot of a wearer (or the socked foot of a wearer) in the regions around one or more of holes 31, 32, 33 and 34, and air can directly reach the interior of shoe 10. In other embodiments, upper 11 of shoe 10 may include an additional lining (e.g., a "bootie") between substrate layer 27 and a wearer's foot. In such embodiments, air cannot directly reach the wearer's foot through holes 31, 32, 33 and 34, but ventilation is still improved relative to many conventional constructions, as materials used for a bootie or other liner are typically porous and significantly more breathable than materials used for substrate layer 27.

**[0054]** The number, size and location of ventilation holes in the substrate layer 27 will vary in different embodiments. In some embodiments, an upper may include ventilation holes as small as (or smaller than) 2 mm in diameter, while in other embodiments, the ventilation holes may be quite large and cover a substantial portion of the upper. In some embodiments, minimum spacing between some ventilation holes can be based on the minimum area needed to effectively bond the mesh and substrate layer materials used for a particular embodiment.

**[0055]** The material of skin layer panels 36a, 36b, 36c and 36d provides abrasion protection for mesh layer 28. A skin material panel can also be added for decorative purposes. For example, skin material elements can include one or more additional elements such as element 36d in the shape of a logo or other identifier of the manufacturer of shoe 10. Much of skin layer panels 36a-36d overlap (or are overlaid on) mesh layer 28. Where such skin/mesh overlap areas further

overlap substrate layer 27, skin/mesh/substrate overlap areas occur. According to embodiments of the invention, bonding agent may be selectively disposed between the mesh and skin layers, within one or more skin/mesh overlap areas and/or within one or more skin/mesh/substrate overlap areas. It is also possible for one or more areas or regions of skin layer panels to be directly bonded to substrate layer 27, without an interposing layer of mesh material. For example, and as described in more detail below in connection with FIGS. 4A1-4L, skin layer panels 36a-36c cover some portions of substrate layer 27 over which mesh layer 28 does not extend. Moreover, and as also described in more detail below, a portion of skin layer panel 36a overlays (and is bonded to) foxing panel 17. In some cases, an interposing mesh layer is omitted for structural purposes. An interposing mesh layer could also be omitted for decorative reasons. According to further embodiments of the invention, bonding agent may be selectively disposed between the substrate and skin layers, within one or more substrate/skin overlap areas. However, as discussed in greater detail below, skin layer panels 36a-36d used to form skin layers are often a hot melt bonding material such as TPU or include a layer of such material. In such cases, skin layer panels 36a-36d can provide bonding with any adjacent overlapping layers, including substrate layer 27 or mesh layer 28, following a hot pressing operation, without the need for a separate bonding agent (i.e., a bonding agent separate from the skin layer and disposed in a separate application, apart from the positioning of skin layer panels 36a-36d) to be disposed between these overlapping layers.

**[0056]** Shoe 10 includes a foamed ankle collar 141, a heel counter (not shown) and a tongue 41. Tongue 41 may be stitched or otherwise bonded to the inside of upper 11. Attachment of collar 141 is described below. Upper 11 may be attached to a midsole 42 in any of various manners. In some embodiments, upper 11 is slip lasted and attached to a Strobel layer, with that Strobel layer then bonded to an upper face of midsole 42. Other types of constructions are used in other embodiments to attach upper 11 to a midsole or other sole component. One example of such a construction is discussed below in connection with FIGS. 15A and 15B.

**[0057]** As can also be seen in FIGS. 1A and 1B, the pattern of the mesh material of mesh layer 28 (represented in FIGS. 1A through 1C as a coarse diagonal grid) is exposed over a substantial portion of composite panel 16. In particular, that mesh material is directly visible in regions of panel 16 not covered by one of skin layer panels 36a-36d. In much of the areas covered by skin layer panels, however, the pattern of the underlying mesh material is still visible because of the skin layer conformance to that mesh. In some embodiments, the pattern of the mesh material in the mesh layer is visible over a substantial portion (or even most) of the surface of the mesh composite panel in the finished shoe. This pattern may be visible directly in areas where the mesh is exposed (e.g., over openings 31, 32, 33 and 34 and in the regions surrounding those openings) or as a contour of a skin layer panel (e.g., the portion of skin layer panel 36a shown in FIG. 1C). In some embodiments, the percentage of exposed mesh will depend on the purpose of the shoe.

**[0058]** Shoe 10 of FIGS. 1A and 1B is merely one example of a shoe having a multilayer bonded mesh composite upper panel according to certain embodiments. Additional embodiments include other styles of shoes, shoes with different types of midsole/outsole combinations, shoes with different

patterns of substrate material holes, and shoes with different skin material configurations. Still other embodiments include shoes with additional layers and/or layers of additional types of materials.

**[0059]** FIG. 2 is a partially schematic diagram showing creation of multilayer bonded mesh composite panel 16. Substrate layer 27, mesh layer 28, and skin layer panels 36a-36d are assembled in a manner described below. For purposes of explanation, substrate layer 27 is shown in cross-sectional views with fine stippling, skin panels are shown with coarse stippling, and mesh layer 28 is shown with cross-hatching. The open areas between the cross-hatched portions of mesh layer 28 correspond to mesh material openings.

**[0060]** Interposed between mesh layer 28 and substrate layer is a bonding agent 39 that is deposited along the length of the entire cross-section shown in FIG. 2, over which substrate layer 27 and mesh layer 28 overlap to provide a representative mesh/substrate overlap area. Optionally, another layer of hot melt bonding material 40, for example of a same or different composition compared to bonding agent 39, may be placed between mesh layer 28 and skin layer panels 36a-36d. This is often not required, however, as a hot melt bonding material may be conveniently included in skin layer panels 36a-d, obviating the need for a separate layer of such material. Bonding agent 39 may be a hot melt material such as TPU or other thermoplastic polymer that can be melted at a suitable temperature, achieved during a hot pressing operation, to effectively bond the adjacent layers. In addition to TPU, representative thermoplastic polymers include polyesters, polyamides (both co-polymers, i.e., co-polyamides, and homopolymers), polyvinyl acetate (PVA), vinyl acetate co-polymers (e.g., ethylene vinyl acetate (EVA) and polyethylene vinyl acetate (PEVA)), and blends thereof. A particular group of thermoplastic polymers is selected from TPU, vinyl acetate copolymers, and copolyamides. A representative melting temperature of the bonding agent, whether it is TPU or another thermoplastic polymer, is from about 80° C. to about 120° C. Bonding agent 39 is generally in the form of a powder or tackified powder, allowing its application to bonding areas of overlapping panels to be judiciously controlled, without causing significant waste. A representative average particle size for the bonding agent, which provides a combination of good handling and melting characteristics, is less than about 500 microns (μm), and preferably in the range from about 100 microns (μm) to about 400 μm.

**[0061]** Generally, bonding agent 39 is selectively deposited onto the substrate panel that forms substrate layer 27 in the bonded mesh composite, although, according to alternative embodiments, bonding agent 39 may be deposited onto the mesh panel that forms mesh layer 28. Also, it is not necessary for bonding agent to be deposited as a substantially continuous layer, as illustrated in FIG. 2, because the form of the bonding agent, namely a powder or tackified powder form, allows it to be deposited at one or more discreet locations within any of overlap areas described herein. For example, the bonding agent may be deposited as a number of small dots or regions within an overlap area or otherwise around the perimeter region within an overlap area but not in a central region. The placement of the bonding agent in specific regions or locations of a panel (e.g., a substrate panel) and in specific amounts may be facilitated by depositing the bonding agent, in powder form,

through a screen, template, stencil, or other type of overlay. The quantity of bonding agent deposited in any region (within any overlap area), may be appropriately controlled to achieve the desired bonding characteristics, with the maximum utilization and minimum waste.

**[0062]** Quantities of bonding agent deposited within different overlap areas may also be varied to achieve any number of desired effects in the bonded mesh composite, following hot pressing to melt the bonding agent and thereby form the bonded mesh composite. For example, the bonding agent may be disposed within first and second mesh/substrate overlap areas to achieve differing bonding agent thicknesses, patterns, shapes, designs, and/or colors in these differing overlap areas. Therefore, according to particular embodiments, the thickness of a first bonding layer, of the bonding agent disposed within a first mesh/substrate overlap area, differs from the thickness of a second bonding layer, of the bonding agent disposed within a second mesh/substrate overlap area. Likewise, shapes and/or colors of these first and second bonding layers can also differ to create desired visual effects, including three-dimensional effects, as a result of varying the bonding layer thickness. The same effects can be achieved by depositing the bonding agent in the form of a powder or tackified powder as described herein, in other areas of overlap between layers, such as in mesh/skin overlap areas. Differing bonding layer thicknesses, shapes, and/or colors, within differing overlap areas, can be achieved using the same bonding agent or a different bonding agent within the different overlap areas. The color effect can be achieved by pigmenting the bonding agent to be used in the differing overlap areas with different pigments.

**[0063]** In general, the bonding agent, such as a TPU in powder form, may be clear, and when it is used to bond two panels, may be visible on at least one side of the bonded mesh composite, depending on the characteristics of the layers of material between which it is disposed. For example, the bonding agent may appear as a glue line underneath a layer of the bonded mesh composite. Thus, the bonding agent can be selectively laid down, or deposited, to produce desired aesthetic features, for example by forming an outline or logo in the bonded mesh composite. If the bonding agent is colored, for example by adding a pigment, the color may also be visible through an exterior layer, such as a skin layer. The use of a powder or tackified powder provides a form of the bonding agent that affords significant flexibility in the fabrication of an upper having a bonded mesh composite as described herein.

**[0064]** After the layers shown in FIG. 2 are tacked together, the assembly is covered with a heat conductive silicone pad 44 and put into a heated press 45, with the skin material panels facing silicone pad 44. Heat and pressure are then applied to activate the bonding agent and to cause the skin material to reach its melting point. As a result, the bonding agent in layer 39 bonds substrate layer 27 to mesh layer 28, the skin material of panels 36a-36d begins to conform (and further bond) to the mesh material of layer 28, and the various layers bond to become a one-piece panel. After that heated pressing, the layers then may be pressed again in a separate cool press (not shown). Additional details of the pressing operations are provided below.

**[0065]** In some embodiments, a separate panel of hot melt bonding material may be placed between a skin layer panel 36a-36d and a mesh layer panel 28 to bond these panels. Often, however, the skin layer panel is bonded to the other

layer(s) solely through the melting of the skin layer panel so as to fuse the skin layer to one or more other layers. Moreover, due to the use of the bonding agent, having been selectively deposited as a powder or tackified powder, between the substrate and mesh panels as described above, a separate panel of hot melt bonding material is generally not present between these material panels, as such separate panel is unnecessary. Likewise, the use of hot melt bonding agent, laminated as a film to substrate layer 27, may also be advantageously avoided. Such prelaminated panels of two-layer substrate materials generally have a first material layer (e.g., artificial leather) and a second material layer (e.g., thermoplastic polyurethane) prelaminated to a face of the first material layer by the substrate material manufacturer.

**[0066]** When such panels of that two-layer substrate are cut to shape by a shoe manufacturer and used as substrate layer 27, losses of the cut-away material, including the hot melt material present in the second material layer, invariably result. Aspects of the present invention, directed to depositing the bonding agent selectively, where it is needed during fabrication of the upper, effectively address such hot melt bonding material losses and the associated costs. Similarly, such losses of the hot melt bonding material can be incurred when large sections of mesh and/or or skin material have a separate hot melt bonding material that is pre-applied (e.g., laminated as a laminate film layer by the material supplier or otherwise laminated in a preprocessing step by a shoe manufacturer), prior to cutting of individual upper panels from the large material sections. According to preferred embodiments of the invention, therefore, the substrate panel, used to form the substrate layer, does not include a material layer of hot melt bonding material. Likewise, such a material layer may be absent from the mesh panel and/or the skin panel, although, as discussed above, the skin panel can in some cases comprise a hot melt material that beneficially melts under hot press conditions to help fuse mesh and/or substrate materials, providing additional bonding and structural integrity.

**[0067]** FIG. 3 is a partially schematic cross-sectional view from the location indicated in FIG. 1A showing the structure of mesh composite panel 16 after hot and cold pressings. For purposes of illustration, three different regions are labeled in FIG. 3. Region A corresponds to the location of the mesh composite panel 16 (FIG. 1A) where hole 32 in substrate layer 27 is located. Because no other material layers are present in region A, the mesh material of layer 28 is not bonded to another material in this region. If upper 11 includes a liner (i.e., on the inner side of substrate layer 27), such as is shown in FIG. 3 with a broken line, the mesh material of layer 28 is in at least some embodiments not bonded to that liner in the region of holes in substrate layer 27. In some embodiments, however, a liner may be stitched to mesh layer 28 and/or other portions of shell 11 in some locations and/or bonded to the inside surface of substrate layer 27 at some locations.

**[0068]** Region B in FIG. 3 corresponds to a location of mesh composite panel 16 (FIG. 1A) where no skin material panel is present, but where substrate layer 27 and mesh layer 28 overlap, providing a mesh/substrate overlap area. Region C corresponds to a location where substrate layer 27, mesh layer 28 and skin layer panel element 36a are present, to provide a skin/mesh/substrate overlap area. In regions B and C, the substrate material of layer 27 and the mesh material of layer 28 are bonded together at surfaces where those two

material layers are in contact. As shown in FIG. 3, the bonding agent 39 is selectively disposed between the mesh and substrate layers to provide this bonding. Generally, the bonding agent may be disposed in one, several, or all mesh/substrate overlap areas. According to other embodiments, the bonding agent may be selectively disposed between the mesh and skin layers to provide this bonding in one, several, or all skin/mesh/substrate overlap areas, and/or selectively disposed between the substrate and skin layers to provide this bonding in one, several, or all substrate/skin overlap areas.

**[0069]** The presence of the bonding agent within any such overlap area does not require the bonding agent to cover the entire area. As discussed above, the use of a bonding agent as a powder or tackified powder allows it to be selectively disposed at discreet locations, if desired, over only a portion of an overlap area. For example, during fabrication of the upper, the bonding agent may be deposited over from about 10% to about 90%, or from about 30% to about 80%, of one or more mesh/substrate overlap areas, one or more mesh/substrate/skin overlap areas, and/or one or more substrate/skin overlap areas, with reduced coverage areas corresponding to greater material savings. Although the bonding agent may be deposited over less than a complete overlap area, the resulting layer of bonding agent, following the effects of heat and pressure from the hot pressing operation, may ultimately be disposed, in the fabricated bonded mesh composite, in all or substantially all of the overlap area. According to some embodiments, control of an amount of bonding agent that is deposited in an overlap area allows the bonding agent layer, following hot pressing, to have a reduced thickness in the bonded mesh composite, relative to conventional laminate layers (e.g., having a thickness of 200  $\mu\text{m}$ ) of hot melt bonding material. For example, the bonding agent layer in a representative bonded mesh composite panel of a fabricated upper may have a thickness of less than 200  $\mu\text{m}$ , with a representative thickness being in the range from about 10  $\mu\text{m}$  to about 100  $\mu\text{m}$ . The potential reduction in the thickness of the resulting layer of bonding agent, when selectively deposited as a powder or tackified powder, can further beneficially lower the overall weight and thickness of the fabricated upper and shoe, as well as enhance breathability and reduce overall material requirements.

**[0070]** As shown in FIG. 3, skin layer element 36a and the substrate material of layer 27 may be bonded together at all surfaces where those materials contact, as is the case with skin layer element 36a and the mesh material of layer 28. Other skin material panels may be similarly bonded to the substrate material of layer 27 and the mesh material of layer 28. As discussed above, according to some embodiments, skin layer element 36a may itself be a hot melt bonding material, such that the use of additional bonding agent in the form of a powder or tackified powder is not necessary to bond skin layer element 36a. Whether bonding occurs using the bonding agent, a separate layer of hot melt bonding material, skin material, or a laminated film layer, bonding of substrate and mesh materials, and/or skin materials, effectively fuses the materials together so as to create a material that is stronger than the individual components.

**[0071]** As also seen in region C of FIG. 3, the skin material of panel 36a conforms to the mesh material of layer 28 so that a contour of the mesh material pattern is revealed through panel 36a. Other skin material panels that overlay mesh layer 28 similarly conform to the mesh material. In this

manner, upper **11** can have a more continuous appearance than might otherwise be possible. By providing layers of skin material that have a texture revealing an underlying mesh material, a potential purchaser of shoe **10** is also made aware of the structure of shoe **10**. Moreover, it is believed that the conformal nature of the contact between a skin material panel and underlying mesh and/or substrate layer materials helps to increase the bonded surface areas and overall material strength.

**[0072]** By being selectively disposed in the bonded mesh composite, the bonding agent may be left out of, or absent from, certain areas in which the substrate layer does not overlap the mesh layer but instead overlaps the skin layer, which can itself provide bonding in some embodiments. Again, by selectively depositing the bonding agent during fabrication, as opposed to indiscriminately pre-applying (even where not required) the bonding agent to all areas of, for example, the substrate by lamination, material is conserved and cost benefits can be realized.

**[0073]** As indicated above, the substrate material of layer **27** provides support and protection for the foot of a wearer of shoe **10**. In at least some embodiments, the substrate material is (or includes) a synthetic leather or another material that is sufficiently durable to protect a foot in regions where the upper is likely to contact external objects and/or where foot support is needed, but sufficiently flexible to provide comfort.

**[0074]** Many different substrate materials can be used. In some embodiments, substrate materials are selected so as to provide support for the package of bonded materials (i.e., the stack of substrate, mesh and other materials assembled to create an upper) and to adequately bond to the mesh material. To achieve such goals, substrate materials can be chosen so as to have limited stretch, to bond well and be chemically compatible with the bonding agent, to have a continuous (i.e., non-mesh) surface so as to provide more bonding surface area, and to be cuttable with clean edges in mass production. Table 1 lists examples of substrate materials that can be used in at least some embodiments; other materials could also be used.

TABLE 1

Material Type/Description	Example Commercially-Available Product
EPM synthetic suede 0.5-1.0 mm thick	CLARINO TIRRENINA NUBUCK (Kuraray America, Inc., New York, NY)
regular density synthetic leather	SOFT-R 1.1 mm (Nan Ya Plastics Corporation, Taiwan)
microfiber synthetic leather	THUNDER II, 1.4 mm (Nan Ya Plastics Corporation, Taiwan)
EPM synthetic leather with 50% rePET in high density substrate	KANGA ENV 1.3 mm or 1.5 mm (Nan Ya Plastics Corporation, Taiwan)
buffed high density synthetic leather	KITE BUFF 0.9 mm (Daewoo International Corporation, Pusan, Korea)
poly/nylon nonwoven	EVO80 WS (Freudenberg & Co., Weinheim, Germany)
perfed microfiber polyester textile	LJ-M11K (Gold Long John International Co, Taiwan)
polyester textile package	POLYPAG PLUS MULTI (You Young Co., Ltd., Korea)
polyester textile package	JEKYLL PLUS MULTI (You Young Co., Ltd., Korea)
TPU coated synthetic leather	A806/A807 (Chaei Hsin Enterprise Co., Ltd., Taiwan)

**[0075]** The mesh material of mesh layer **28** reinforces upper **11** by augmenting the strength of the substrate mate-

rial where the two materials overlap and may be bonded by the selectively disposed bonding agent, as described herein. This strength augmentation advantageously allows the use of thinner substrate material elements. Incorporation of mesh material into an upper further allows elimination of substrate material, as well as bonding agent, in areas where the full protection and support of the substrate material is not as important, thus permitting further reduction in material costs and overall shoe weight. The mesh material of mesh layer **28** also allows air to flow through openings in substrate layer **27** to help cool and dry the foot of a wearer.

**[0076]** In at least some embodiments, the mesh material of layer **28** is a single layer warped knit with an open structure (or other type of woven material) and is formed from nylon, polyester, nylon/polyester blends, recycled polyethylene terephthalate (rePET), or other material. In certain embodiments, the mesh material has more than 50% open area (e.g., more than 50% of the material surface area comprises open space through which air can freely flow from one side to the other). In some embodiments, SPANDEX (or other stretchable meshes) and spacer meshes (meshes with filler yarn) are undesirable. Table 2 lists examples of the mesh material in at least some embodiments; other materials could also be used.

TABLE 2

Material Type/Description	Example Commercially-Available Product
100% PET mesh	E-minicell mesh 420D single mesh (Daewoo International Corporation, Pusan, Korea)
35% rePET mesh	BULLHEAD mesh (Formosa Ting Sho Co., Ltd., Taiwan)
38.6% rePET mesh	TENOR mesh (Joonang Textile Co., Ltd., Korea)
34% nylon 200D/84F, 66% polyester 300D/168F	AIR TING mesh (Mogae Textile Co., Ltd., Busan, Korea)
32% polyester 100D/36F, 68% polyester 300D/168F	TLE8B001 DUONET (Tiong Liong Industrial Co., Ltd., Taiwan)
50% rePET mesh	TLD9B018 BLOCKBUSTER (Tiong Liong Industrial Co., Ltd., Taiwan)
30% rePET mesh	MATRIX mesh (You Young Co., Ltd., Korea)
30% rePET mesh	MONO RIB mesh (Dong Jin International Corporation, DaeGu, Korea)
30% rePET mesh	thermoplastic mesh 6 (Duck San Co., Korea)
Love Look	Egg mesh (You Young Co., Ltd., Korea)
	Formosa Ting Sho Co., Ltd., Taiwan

**[0077]** The skin material for panels **36a-36d** reinforces the mesh and substrate materials, protects the mesh material layer in certain areas (e.g., provides abrasion resistance), and/or provides a decorative surface on upper **11**. In at least some embodiments, the skin material is a thermoplastic polyurethane (TPU) or other appropriate material, which may be the same or different from that of the bonding agent. In certain embodiments, the skin material is a multilayer material having an outer heat-resistant layer for abrasion resistance and an inner layer for hot melt bonding. For example, the outer layer can be thermoset polyurethane (PU) or a TPU with a high melt temperature, and the inner layer can be a TPU having a lower melt temperature suitable for hot melt bonding and production temperatures. Alternatively, a hot melt bonding layer may be absent from the skin material, such that bonding between the skin material and other layers is achieved using the bonding agent as described

herein, being selectively disposed between the skin layer and any adjacent layers (e.g., the mesh layer or the substrate layer).

**[0078]** Table 3 lists examples of materials that can be used for the skin material in at least some embodiments; other materials could also be used.

TABLE 3

Material Type/Description	Example Commercially-Available Product
0.4 mm thermoset polyurethane (PU) film TPU film	UT900 (San Fang Chemical Industry Co., Ltd., Taiwan) FW film (Daewon Chemical Company, Ltd., Korea)
Dual (H/L) TPU film having 0.1 mm high melting temp. aliphatic film layer and 0.2 mm low melting temp. aromatic polyester film FS8080 layer	FD26K series (Ding Zing Chemical Products Co., Ltd., Taiwan)
0.3 mm film having 0.1 mm PU layer and 0.2 mm TPU hot melt layer	SKN300 (Teijin, Okahata, Japan)
0.35 mm PU coated hot melt film	HH Million AB (Daewoo International, Busan, Korea)

**[0079]** Various layers of material may be bonded, according to some embodiments, at least partially over some portion of their respective surfaces, by interposing a separate layer of hot melt bonding material between those materials and then activating that bonding material in a heated press. In at least some embodiments, the hot melt bonding material generally has a pre-activation consistency of a fine fibrous mat that is similar in thickness (and appearance) to a fine spider web. This allows the activated bonding material to fully cover contacting surfaces without excess buildup of hardened bonding material. In some embodiments, hot melt bonding material mats can be laid onto sheets of mesh and skin material, with the sheets then rolled and provided to a shoe manufacturer. The manufacturer can then unroll the mesh and bonding material combination (or the skin and bonding material combination) and cut appropriate shapes for an upper in a single die-cutting operation.

**[0080]** In at least some embodiments, a TPU hot melt bonding material could have a melt temperature between 80° C. and approximately 120° C. and can be polyester-based. Table 4 lists examples of hot melt bonding materials that can be used in at least some embodiments; other hot melt bonding materials could also be used.

TABLE 4

Material Type/Description	Example Commercially-Available Product
hot melt film polyurethane/polyester base hot melt film hot melt film	F1500 (Duck San Co. Ltd, Seoul, Korea) FS8080 (Ding Zing Chemical Products Co., Ltd., Taiwan)
hot melt film hot melt film	FS4252X3 (Ding Zing Chemical Products Co., Ltd., Taiwan) NASA 600 (Sambu, Korea)
polyether film (0.05 mm to 2 mm thickness)	Meltlace Web 100E (Dongsung Adhesives division Henkel AG & Co. KGaA) FT1029 (Ding Zing Chemical Products Co., Ltd., Taiwan)

**[0081]** The final material in Table 4 (polyether film) may be desirable, e.g., in certain embodiments in which high humidity is a concern.

Fabrication of an Upper Shell Having a Mesh Composite Portion

**[0082]** According to at least some embodiments, a bonded mesh composite panel of an upper is created by assembling individual panels of material, which form the various layers of the bonded mesh composite, in a flat configuration. If the upper is to include additional portions (e.g., a rear portion such as panel 17 of shoe 10), additional material elements can be included as part of the assembly process. The panels and other elements are assembled so as to have an arrangement in which the relative locations of the panels and elements correspond to the locations those panels and elements will have in the completed shoe. After assembling the individual panels and/or other elements into the proper arrangement and optionally tacking the assembly at several locations, the assembly undergoes a series of pressing operations to bond the assembled elements. These operations create a flat, one-piece unibody upper shell that can contain many or all elements to be included in the finished upper. Edges of the unibody upper shell can then be joined to create a three-dimensional upper body ready for further finishing and attachment to a midsole.

**[0083]** FIGS. 4A1 through 4L show a process, according to at least some embodiments, to fabricate the mesh composite panel 16 for shoe 10 of FIGS. 1A and 1B. In step 1 shown in FIGS. 4A1 and 4A2, foxing panel 17 is attached to an assembly jig 100. FIG. 4A2 is a side view of jig 100 and foxing panel 17, from the position noted in FIG. 4A1, that is included to further show the use of jig 100. Each of pins 101a-101q in jig 100 extends upward and is used to position one or more upper elements. For example, and as shown for panel 17, pins 101a, 101b and 101e correspond to holes 102a, 102b and 102e in foxing panel 17. Panel 17 is positioned on jig 100 by respectively placing holes 102a, 102b and 102e over pins 101a, 101b and 101e and pushing panel 17 onto jig 100. The side of foxing panel 17 facing upward at the completion of step 1 will face outward and away from the interior of a completed shoe 10. Hole 102a of panel 17 is in a small extension tab 99 that extends away from an edge 98 of panel 17. Extension tab 99 (and similar extension tabs on other elements) will be trimmed away during a later stage of fabrication.

**[0084]** Other elements of upper 11 are positioned on jig 100 in a similar manner. In step 2 (FIG. 4B), for example, a panel 53 of hot melt bonding material is placed adjacent an edge 54 of foxing panel 17. Bonding material panel 53 may be used to bond foxing panel 17 to a panel of substrate material that will become substrate layer 27 of mesh composite panel 16. In other embodiments, foxing panel 17 can be attached in a different manner (e.g., by relying on the melting of a laminated layer of foxing panel 17, by using a brushed-on liquid adhesive) and/or at a different stage of constructing an upper shell. In yet other embodiments, a bonding agent may be used to bond foxing panel 17, in the manner as discussed below with respect to the bonding of other materials (e.g., the bonding of mesh and substrate panels as discussed in step 5).

**[0085]** In step 3 (FIG. 4C), a panel of material for substrate layer 27 is attached to assembly jig 100 by pushing holes 104b through 104q in the substrate material panel over pins



101b through 101q, respectively. Holes 104b-104d, 104f and 104p are contained in extension tabs that will be trimmed away in a subsequent fabrication step. As seen in FIG. 4C, the panel of layer 27 includes opening 34 that will ultimately be located in the top forefoot region of upper 11 (see FIGS. 1A and 1B). Also seen in FIG. 4C are openings 31 and 32 that will ultimately be located laterally on upper 11 (FIG. 1A) and opening 33 that will ultimately be located medially on upper 11 (FIG. 1B). In some embodiments, holes 31, 32, 33 and 34 are cut when the substrate layer panel is die-cut from a larger piece of material. Tongue opening 26 (FIGS. 1A and 1B) will be cut after assembly and pressing. In other embodiments, tongue opening 26 can also be cut from the substrate material panel when that panel is die cut. The side of the layer 27 panel that is exposed at the completion of step 3 will face outward and away from the interior of a completed shoe 10.

[0086] In step 4 (FIG. 4D), eye stay reinforcement 56 is attached to jig 100 by pushing holes 108g, 108h, 108i and 108o over pins 101g, 101h, 101i and 101o, respectively. Eye stay reinforcement 57 is similarly attached by pushing holes 109j, 109k and 109l over holes 101j, 101k and 101l, respectively. In at least some embodiments, reinforcements 56 and 57 are added to provide reinforced locations for shoe lace eyelets. In other embodiments, eye stay reinforcements may be omitted or may have different configurations. Panels of unactivated hot melt bonding material can also be interposed between reinforcements 56 and 57 and substrate layer 27.

[0087] Other types of reinforcements can be placed in other areas of a shoe upper in a manner similar to that used for eye stay reinforcements 56 and 57. In some embodiments, for example, additional reinforcement could be placed over the area of the substrate layer panel that will be located in the toe region of a completed upper. In another embodiment, reinforcement materials could be placed over the portions of the substrate layer panel that will be located at the lateral and medial sides of a completed shoe, with those reinforcement materials forming reinforcing strap attachment points in a finished upper.

[0088] In step 5 (FIGS. 4E1-4E4), bonding agent 39 is selectively deposited onto the substrate panel 27 substantially in entire mesh/substrate overlap area 150 (i.e., to be overlapped in a subsequent step of positioning a mesh panel) as a powder or tackified powder. The application of powder may be assisted using a screen, template, stencil, or other type of overlay to accurately direct the powder to desired locations. In the case of a screen, the screen may function to adjust the particle size range of the bonding agent to a narrower range (e.g., having an upper size limit in the range from about 200  $\mu\text{m}$  to about 600  $\mu\text{m}$ ) that may, for example, be more easily melted (or tackified) or at least melted (or tackified) with greater consistency (e.g., by screening out large particles that require a greater hot press time and/or temperature for complete melting). Bonding agent 39, in powder form, may also be screened, prior to selectively depositing it onto the substrate (i.e., prior to use), to adjust its lower size limit (e.g., within the range from about 50  $\mu\text{m}$  to about 150  $\mu\text{m}$ ) and thereby limit the amount of fines, which tend to migrate easily. Both the lower and upper particle size limits of the powder may also be adjusted through screening, prior to use. According to yet other embodiments, the bonding agent 39, in powder form, may be obtained as a raw material already having a desired particle size range, in which case the screen does not necessarily

function to adjust particle size, but rather functions primarily or solely (as with a stencil, template, or other type of overlay) for precise placement of the powder onto panel that forms substrate layer 27, or other panel surface. In addition to, or as an alternative to, its function of placing the bonding agent in desired locations, the screen can also serve the purpose of ensuring an even layer deposition of the bonding agent, thereby improving the application, for example, of the bonding agent to the substrate layer.

[0089] As discussed above, the use of powder advantageously provides significant flexibility in terms of the quantity of bonding agent applied to a given location within an overlap area, and therefore the thickness of the bonding agent layer that results following hot pressing to form the bonded mesh composite. Consequently, the bonding agent may be deposited onto the substrate panel in two or more different mesh/substrate overlap areas in amounts that, following compressing the substrate and mesh panels under the bonding conditions, form a bonded mesh composite having different thicknesses of the bonding agent in the different mesh/substrate overlap areas. Varying thicknesses of the layer of bonding agent can also be obtained within a single overlap area to provide, for example, a wavy surface, or other desired, textured surface, which can be seen and/or felt over at least a portion of the fabricated upper.

[0090] The use of powder, for example in combination with an overlay, allows the bonding agent to be deposited in a plurality of discreet locations, for example to form a pattern, shape, image, or design (e.g., a logo) in an overlap area (e.g., in one or more mesh/substrate overlap areas). Accordingly, FIGS. 4E2, 4E3, and 4E4 provide alternative embodiments, relative to the embodiment illustrated with respect to FIG. 4E1, in which bonding agent 39 may be selectively deposited onto substrate panel 27, and particularly deposited in one or more regions within overlap area, which region(s) constitute(s) only a subset of the entire overlap area. The embodiments illustrated in FIGS. 4E2, 4E3, and 4E4 may therefore result in the use of a reduced total quantity of bonding agent 39, relative to the embodiment illustrated with respect to FIG. 4E1. For example, in FIG. 4E2, bonding agent 39 is deposited within the same mesh/substrate overlap area as shown in the embodiment illustrated in FIG. 4E1, but is deposited onto substrate panel 27 only around a perimeter region within this overlap area, and not in one or more central regions. In such an embodiment, subsequently applied mesh panel (28 in FIG. 4F) becomes bonded to substrate panel 27 in this perimeter region, while not being bonded other regions (e.g., central regions) of mesh/substrate overlap area. In addition to reducing the overall requirement for bonding agent 39, this embodiment can also provide increased mobility/movement between the substrate and mesh panels to enhance overall air flow and breathability of the finished upper.

[0091] In FIG. 4E3, bonding agent 39 is deposited within the same mesh/substrate overlap area as shown in the embodiment illustrated in FIG. 4E1, but only in regions corresponding to discreet locations (e.g., points or dots) distributed throughout this overlap area. The placement of the bonding agent in specific regions or locations of substrate panel 27, and in specific amounts, may be facilitated by depositing bonding agent 39, in powder form, through a screen, template, stencil, or other type of overlay. FIG. 4E4 illustrates yet another embodiment in which bonding agent 39 is deposited within the same mesh/substrate overlap area

as shown in the embodiment illustrated in FIG. 4E1, but only in regions that form a wave pattern within this overlap area. Depending on the thickness(es) and/or color(s) used for bonding agent 39, the embodiments illustrated in FIGS. 4E3 and 4E4, as well as FIG. 4E2, may achieve a textural or aesthetic effect, as the formed pattern or other design of the deposited bonding agent may be perceived by feel and/or sight, even following the subsequent application of mesh layer and/or additional layers. As discussed above with respect to the embodiment illustrated in FIG. 4E2, the embodiments illustrated in FIGS. 4E3 and 4E4 can also reduce the overall requirement for bonding agent 39 and/or increase breathability of the finished upper.

**[0092]** Thus, according to particular embodiments, the bonding agent may be selectively deposited for a certain application by building up the powder in desired regions to emphasize an aesthetic feature and/or provide additional support. This may be accomplished, for example, by using a thicker screen base, or otherwise using multiple screening steps, in regions where a thicker application of the bonding agent is desired. Multiple screening (or “stenciling”) steps may also be used to selectively deposit bonding agent powder having different colors in the same or different regions. In this manner, bonding agents may be selectively deposited in powder form to achieve varying thicknesses and varying color effects. According to an embodiment of depositing the bonding agent as a tackified powder, the bonding agent is first applied (e.g., through a screen) to a panel and then tackified by the application of heat (i.e., preheating), prior to the application of an overlapping panel. In the case of the bonding agent being applied to a panel in successive steps, (e.g., in a plurality of screening steps), the bonding agent may be tackified after each of these successive steps, and a non-tackified (or non-preheated) portion of the bonding agent may be removed between these successive steps (and optionally reclaimed for recycle or later use).

**[0093]** In general, improved control over the placement of the bonding agent may be possible, according to some embodiments, if the bonding agent is deposited as a tackified powder. In this case, the individual powder particles are held together, associated, or agglomerated at least to some extent by preheating the powder or combining the powder with a paste forming agent, for example a weak aqueous-based or organic-based adhesive, to form a paste from the powder particles. One consideration associated with paste formation is that the settling out or separation of solid particles should be avoided. The paste forming agent should therefore have sufficient viscosity and other properties that prevent the separation of a substantial portion of the solid particles, over the time period from when the paste is formed until it is used as a bonding agent. Separation of the solid particles of bonding agent can also be directionally hindered by reducing the average particle size of this solid material. Therefore, according to some embodiments, when the bonding agent is deposited as a tackified powder, its average particle size is smaller than the representative average particle sizes described above (e.g., from about 100  $\mu\text{m}$  to about 400  $\mu\text{m}$ ). A representative average particle size of the bonding agent, when selectively deposited as a tackified powder, is from about 1  $\mu\text{m}$  to about 100  $\mu\text{m}$ . The use of a paste forming agent to provide the bonding agent as a tackified powder has the additional advantage of preventing fine solid particles from migrating from the desired areas or regions of bonding, or otherwise from the material layers altogether. Additional,

desirable properties of the paste forming agent include compatibility with the layer or panel (e.g., substrate layer or panel) on which application is intended. For example, in the case of bonding agent to be applied to a synthetic leather substrate panel, if this bonding agent is deposited as a tackified powder comprising a paste-forming agent, then the latter component should preferably have a high affinity for the fibers of the panel, in order to promote good penetration and bonding. A paste or emulsion of the powder, in tackified form, may be selectively deposited onto a substrate panel or other panel using any of a number of applicators, for example a using a brush, a pen-like applicator having a reservoir and an applicator tip, a tube, a syringe, etc., with the particular applicator often depending on the consistency (e.g., viscosity) of the tackified powder. For tackified powder compositions of a consistency that is nearly solid or approaches that of a solid, a tape-like dispenser may be used to apply or selectively deposit the bonding agent onto one or more panels.

**[0094]** If preheating of the bonding agent is used to provide a tackified powder, representative preheating temperatures (i.e., temperatures to which the bonding agent is heated to tackify the powder) are from about 90° C. to about 120° C., depending on the particular bonding agent used. The main consideration with preheating the bonding agent, in order to provide a tackified powder, is to cause some sticking (agglomeration) of the individual powder particles. This preheating may occur prior to depositing the bonding agent, as a tackified powder, onto the substrate and/or mesh panels in the appropriate overlap area(s) (e.g., mesh/substrate overlap area(s) and/or skin/mesh/substrate overlap area(s)). Alternatively, the preheating may occur on the panel onto which the bonding agent is initially deposited in powder form. According to a specific embodiment, preheating of the bonding agent, to provide a tackified powder, is accomplished by heating the panel (e.g., the substrate panel) on which the tackified powder is to be deposited. If the powder is to be deposited through a screen or other type of overlay, then the material used for this screen or overlay may be an insulating (e.g., non-metallic) material that maintains portions of non-deposited powder of the bonding agent, in contact with the overlay, at a relatively cool temperature (e.g., at room temperature) to prevent such portions from becoming tackified.

**[0095]** Therefore, when the bonding agent is selectively deposited as a tackified powder that is obtained by preheating, this preheating of the bonding agent in powder form can occur on a panel (e.g., the substrate panel), prior to positioning one or more mesh panels onto the substrate panel. In a specific embodiment, the bonding agent, in powder form, may be preheated on a panel using a laser. A laser can be used, for example, to provide preheating of the bonding agent in precise locations, allowing for the preheating of powder in a particular design or pattern. Often, a higher level of detail can be achieved using laser preheating and tackification, as compared to use of a screen or stencil. Following the formation of tackified powder, for example, in a desired pattern, excess bonding agent that remains in powder form may be removed, for example, by mechanically agitating the panel (e.g., shaking, flipping, spinning etc.) and reclaimed for recycle or later use. According to such embodiments, the desired pattern of tackified powder remains on the panel. As discussed above with respect to the use of multiple screening or stenciling steps, multiple laser preheating steps may also

be used to selectively deposit bonding agent, as a tackified powder, in the same or different regions. One or more bonding agents may be selectively deposited in this manner to achieve varying thicknesses, and consequently strength properties, and varying color effects in a given region. Therefore, according to a specific embodiment of depositing the bonding agent as a tackified powder, the bonding agent is first applied (e.g., through a screen) to a panel such as the substrate panel and then tackified by the application of heat (i.e., preheating) using a laser, prior to positioning overlapping panel(s), such as one or more mesh panels onto the substrate panel. Following the laser preheating to tackify a selected portion of the bonding agent in powder form, and prior to positioning of the overlapping panel(s), a non-tackified (or non-preheated) portion of the bonding agent may be removed, as discussed above. In the case of the bonding agent being applied to a panel in successive steps, the bonding agent may be tackified using a laser, after each of these successive steps, and a non-tackified portion of the bonding agent may be removed between these successive steps (and optionally reclaimed for recycle or later use).

**[0096]** If the bonding agent is deposited as a tackified powder, either preheated or formed into a paste, as described above, it may be applied to the panel from an applicator surface, for example a surface to which the tackified powder has a lower affinity, compared to its affinity for the panel. A representative surface is a recessed surface, such as a gravure cylinder having recesses that may be used to transfer the bonding agent, as a tackified powder (e.g., a paste) to specific locations, and in multiple small portions having specific dimensions, onto a panel such as the substrate panel.

**[0097]** As illustrated in FIG. 4E1, bonding agent 39 is selectively deposited onto substrate panel 27 in an area 150 where mesh is to be applied (i.e., mesh/substrate overlap area) in a later step, with region 112 being included in such area. Bonding agent 39 is preferably not applied over the entire surface of substrate panel 27, for example not in region 110 where there is no overlap with mesh panel or layer 28, as is shown in FIG. 4F. According to alternative embodiments, bonding agent 39 may be omitted from one or more regions of substrate panel 27 where, despite there being overlap with one or more other panels, no bonding between these panels is necessary or desired. Such an embodiment is depicted in FIGS. 4E2-4E4, as well as FIG. 6C, in which the absence of bonding between substrate panel 27' and mesh panel 28' allows for the insertion of another panel or layer 203', such as a foam panel, rubber panel, or other type of panel that can provide reinforcement, support, padding, dimensional stability, desired aesthetics, etc.

**[0098]** In step 6 (FIG. 4F), a panel of mesh material to form layer 28 is attached to jig 100 by pushing holes 119b, 119c, 119d, 119e, 119p and 119q over pins 101b, 101c, 101d, 101e, 101p and 101q, respectively. Mesh panel 28 preferably overlaps all of the bonding agent that is applied as a powder or tackified powder in step 5. According to some embodiments, however, some of the bonding agent may remain exposed even after positioning mesh panel 28 and may be used, for example to bond subsequently positioned panels that provide additional layers of upper 11. Normally, following positioning of mesh panel 28, bonding agent is present in at least part of the total overlapping area 150 between mesh panel 28 and substrate panel 27, and is generally present in one or more desired areas of overlap (i.e., mesh/substrate overlap areas). The bonding agent,

which is normally in an unactivated form or partially activated by preheating to form a tackified powder as described above, becomes fully activated in the subsequent hot pressing operation in which the individual panels are bonded to form the bonded mesh composite panel.

**[0099]** In FIG. 4F, holes 119b-119d and 119p are contained in extension tabs that will be trimmed away in a subsequent fabrication step. The side of mesh layer 28 that is exposed at the completion of step 6 will face outward and away from the interior of a completed shoe 10. In some embodiments, a roll of the mesh material used for the panel of layer 28 may include hot melt bonding material pre-applied to one side, or pre-applied to at least part of one side. The mesh material panel for layer 28 is placed onto jig 100 with the bonding material side facing down (i.e., toward substrate layer 27). In other embodiments, a separate layer (e.g., not in powder form) of hot melt bonding material having the same shape as the layer 28 mesh material panel is placed over substrate layer 27 at the conclusion of step 1, and only a plain mesh material panel is added in step 6. In still other embodiments, a separate panel of hot melt bonding material between panels 27 and 28 is obviated through use of a substrate material having a prelaminated layer formed from a meltable material such as TPU. As discussed above, however, the use of a bonding agent beneficially reduces the need for hot melt material to be prelaminated or pre-applied in layers, since the application of powder or tackified powder allows for more precise control of the amount of bonding agent used and the specific areas on which it is deposited.

**[0100]** As seen in FIG. 4F, the mesh layer 28 panel does not completely cover the substrate layer 27 panel. For example, a region 110 of the substrate material panel (corresponding to the toe and lateral side forefoot regions of an upper in a completed shoe 10) is not overlapped by the mesh material panel in this illustrated configuration, and generally no bonding agent is deposited onto the surface of substrate layer 27 in this non-overlapping region. In this manner, a smooth surface of upper 11 can be provided for subsequent bonding of the bonded mesh composite panel to a toe cap or other external feature. Unlike material used for skin layers, reinforcements 56 and 57 are formed from a thicker material (e.g., nylon) that will not conform as readily to mesh layer 28 at the temperatures used in the pressing process in this example process. Although region 112 of substrate layer 27 corresponds to a region that will subsequently be covered by skin material panel 36d in such a manner so as not reveal an underlying mesh material layer, mesh layer 28 covers region 112 so that the added strength of the mesh material can be present in the portion of upper 11 to which region 112 will correspond in a completed shoe 10.

**[0101]** In step 7 (FIG. 4G), skin material panel 36c is attached to jig 100 by pushing holes 114c, 114d, 114f, 114j and 114p over pins 101c, 101d, 101f, 101j and 101p, respectively. Holes 114c, 114d, 114f and 114p are contained in extension tabs that will be trimmed away in a subsequent fabrication step. Panel 36c will form the skin material covering, e.g., the toe, medial forefoot and lateral forefoot regions on a completed shoe 10 (see FIGS. 1A and 1B). The side of panel 36c that is exposed at the completion of step 6 will face outward and away from the interior of a completed shoe 10.

**[0102]** Skin panel 36c may overlap bonding agent 39 (shown in FIGS. 4E1-4E4) that is deposited onto substrate

panel 27 and/or mesh panel 28, as a powder or tackified powder in the same manner as discussed above with respect to step 5. Bonding agent is preferably deposited in an area of overlap between skin panel 36c and mesh panel 28 (i.e., a skin/mesh overlap area, which generally also overlaps the substrate in a skin/mesh/substrate overlap area), or it may be deposited in an area of overlap between only substrate panel 27 and skin panel 28 (i.e., a skin/substrate overlap area). According to some embodiments, however, some of the bonding agent may remain exposed even after positioning skin panel 36c and may be used, for example to bond subsequently positioned panels that provide additional layers of upper 11. Normally, following positioning of skin panel 36c, bonding agent is present in at least part of the total overlapping area between skin panel 36c and mesh panel 28 and/or between skin panel 36c and substrate panel 27, and is generally present in one or more desired areas of overlap (i.e., skin/mesh and/or skin/substrate overlap areas). The bonding agent, which is normally in an unactivated form or partially activated by preheating to form a tackified powder as described above, becomes fully activated in the subsequent hot pressing operation in which the individual panels are bonded to form the bonded mesh composite panel.

**[0103]** In some embodiments, a roll of the material used for panel 36c and/or other skin material panels may include hot melt bonding material pre-applied to one side, or pre-applied to at least part of one side. The skin material panel for layer 36c is placed onto jig 100 with the bonding material side facing down (i.e., toward mesh layer 28 and substrate layer 27). In other embodiments, a separate layer of hot melt bonding material having the same shape as skin material panel 36c is placed between skin material panel 36c and previously positioned layers as part of step 7. As noted above, however, the use of a bonding agent beneficially reduces the need for hot melt material to be prelaminated or applied in layers. In still other embodiments, one or more skin material panels are bonded to other layers by melting of the skin material during a hot pressing operation (described below) and subsequent solidification during cooling, and no separate bonding material is interposed between those skin material panels and other inwardly-located layers. The skin panel 36c itself may therefore be used to bond mesh panel 28 and/or skin panel 27 in areas of overlap between these panels. For example, in a skin/mesh/substrate overlap area, skin panel 36c may melt during a hot pressing operation, with the melted material flowing by gravity downward through openings in mesh panel 28 and contacting the underlying substrate panel 27 to bond these three layers.

**[0104]** As seen by comparing FIGS. 4F and 4G, skin material panel 36c is assembled so as to be located over substrate layer 27 in region 110 where mesh material is not present (i.e., in a skin/substrate overlap area) as well as in an adjacent region 112 where mesh material is present (i.e., a skin/mesh/substrate overlap area). In some embodiments, extra and/or higher strength bonding agent and/or additional adhesives may be selectively deposited in portions of a composite panel that will correspond to a toe region and/or to other forward regions of an upper of a completed shoe. This additional bonding agent may be desirable in embodiments where toe portions of an upper may experience significant stresses during various manufacturing operations (e.g., toe forming, lasting) and/or use.

**[0105]** In step 8 (FIG. 4H), skin material panel 36b is attached to jig 100 by pushing holes 113g, 113h, 113i, 113j,

113k, 113l, 113n and 113o over 101g, 101h, 101i, 101j, 101k, 101l, 101n and 101o, respectively. The outer edges of panel 36b will face away from the interior of a completed shoe 10, and the remainder of panel 36b (together with portions of the underlying substrate material panel and mesh material panel) will be removed to create tongue opening 26. As with panel 36c in step 6, panel 36b is placed onto jig 100 with the outer side facing up, and bonded to underlying elements with bonding agent that is deposited in the appropriate area(s), or otherwise by melting of panel 36c during a hot pressing operation, followed by resolidifying of the melted material. Alternatively, a layer of hot melt bonding material may be interposed between panel 36b and underlying elements.

**[0106]** Panel 36a of skin layer material is placed onto jig 100 in step 9 (FIG. 4I) by pushing holes 115a, 115b, 115e, 115m, 115n and 115o over pins 101a, 101b, 101e, 101m, 101n and 101o, respectively. Holes 115a, 115b and 115n are contained in extension tabs that will be trimmed away in a subsequent fabrication step. Panel 36a will form the skin material layer covering portions of the lateral midfoot and hindfoot regions on a completed shoe 10. As with panel 36c in step 7, panel 36a may be bonded to underlying elements with bonding agent that is deposited in the appropriate area(s), or otherwise by melting of panel 36a during a hot pressing operation, followed by resolidifying of the melted material. Alternatively, a layer of hot melt bonding material may be interposed between panel 36a and underlying elements. Otherwise, bonding agent may be selectively deposited between panel 36a and underlying elements, as discussed above with respect to step 5 (FIGS. 4E1-4E4). The result at the conclusion of step 9 is a panel assembly 116 of upper elements that will ultimately become an upper shell that includes mesh composite panel 16 bonded to foxing panel 17.

**[0107]** In step 10 (FIG. 4J), in the event that (i) the bonding agent is not tackified by preheating prior to placement of panels overlying the bonding agent and/or (ii) hot melt bonding material is used (either in the form of a laminated layer or a separate layer as discussed above), elements of assembly 116 may be tacked together by partially activating the non-activated bonding agent and/or hot melt bonding material layers in isolated locations. This partial activation can be performed in some embodiments using high frequency (HF) welding or otherwise using laser energy. For purposes of illustration, the resultant tacking is shown schematically in FIG. 4J as a series of dots distributed over the surface of the assembled elements that will form bonded mesh composite panel 16. In practice, the actual locations at which heat is applied for tacking purposes may vary (and may be selectively targeted). Tack welding in step 10 can be performed using a handheld heat gun or a laser, or by briefly inserting jig 100 with assembly 116 into a press having a plate configured to accommodate pins 101a through 101q. In at least some such embodiments, the press conditions for the tacking step will depend on the particular bonding agent and/or hot melt selected, but will typically be between about 115° C. and about 125° C., with pressing for approximately 30 to 35 seconds at approximately 2 to 6 kg/cm<sup>2</sup> of surface pressure.

**[0108]** According to one embodiment, a panel assembly of substrate, mesh, and/or skin panels is laid up, with the bonding agent deposited as a powder or tackified powder, as discussed above, between the various panels in the desired

locations and amounts. Activation of the bonding agent is then carried out by the application of heat and pressure to the assembly. In some cases, a targeted application of heat may be advantageously achieved using a laser. In a specific embodiment, for example, if the bonding agent is initially deposited between panels in powder form, pressure may be applied to the entire assembly (e.g., within the pressure range and duration as described above) using an overlying sheet of laser transparent glass. Laser energy may then be applied at desired locations to selectively activate the bonding agent. If bonding agent is present, for example as a powder, in regions that are not targeted for activation by laser energy (e.g., if the bonding agent is deposited over an entire panel surface but ultimately not needed in all regions of this surface) then the excess powder, following activation (or melting) can be separated as unactivated powder, recycled, and reclaimed. Thus, if the bonding agent is selectively deposited as a powder, laser energy may be applied to the assembly of panels, at one or more locations in order to selectively activate the bonding agent. Representative fabrication methods may further comprise separating excess powder that is not activated by the laser energy in step, optionally followed by recycling and reclaiming this unactivated powder.

**[0109]** The tacking of step 10 results in a partial bonding so that the individual elements of assembly 116 will remain in an assembled condition when assembly 116 is removed from jig 100. In step 11 (FIG. 4K), tacked assembly 116 is heat pressed so as to fully bond the individual elements together. This step, therefore, involves compressing the substrate panel 27 and mesh panel 28, and optionally other panels positioned in jig 100, under bonding conditions (or hot pressing conditions) suitable for forming the bonded mesh composite panel. Representative bonding conditions include a temperature from about 115° C. to about 125° C., a pressure from about 10 kg/cm<sup>2</sup> to about 30 kg/cm<sup>2</sup>, and a time from about 30 seconds to about 40 seconds. Due to the relatively high surface area of the bonding agent powder, heat transfer is facilitated in the hot pressing operation, allowing in some cases for a reduction in the time and/or pressure, relative to the case of a laminated layer of hot bonding agent material. According to alternative embodiments (e.g., in the case of TPU bonding agent), therefore, bonding conditions or hot pressing conditions include a pressure from about 5 kg/cm<sup>2</sup> to about 20 kg/cm<sup>2</sup> and/or a time from about 15 seconds to about 30 seconds. According to one embodiment, tacked assembly 116 is removed from jig 100 and placed onto heat-transferring silicone pad 120. Assembly 116 is turned upside down so that the side facing upward at the conclusion of steps 10 and 11 is positioned to face downward toward pad 120. After a sheet of release paper 121 is placed over assembly 116, heated platens 122 and 123 are brought together and pressure applied to compress assembly 116. For simplicity, only the outer edges of release paper 121 are shown in FIG. 4K. In other embodiments, panel assembly 116 may be placed so that the inner side is facing lower platen 122, with release paper 121 inserted between the inner side of assembly 116 and platen 122, and with pad 120 between the outer side of assembly 116 and upper platen 123.

**[0110]** In at least some embodiments, silicone pad 120 is first preheated to 110° C. prior to the pressing operation of step 11. Typical process parameters for the hot pressing operation of step 10 are upper and lower press platen

temperatures of 120° C., press pressure of approximately 20 kg/cm<sup>2</sup>, and press time of 30 to 40 seconds. However, the process parameters for a particular shoe upper will depend on the combination of materials and on the panel arrangement applicable to that upper. In some embodiments, the press time for step 11 can be determined by assembling panels for a particular upper design into a test panel assembly, with thermocouple temperature probes inserted at one or more locations within the test panel assembly. The test panel assembly is then pressed between 120° C. press platens until the temperature probes indicate that the internal assembly temperature has reached a desired melting point for the skin and/or bonding agent materials in the test panel assembly. If desired, the press time can be adjusted upward or downward by adjusting the press platen temperature. The desired melting point temperature for a particular skin and/or bonding agent materials can be determined by using differential scanning calorimetry (50° C./min scan rate) to find the temperature associated with the maximum heat transfer for that material. Press pressure can be adjusted upward if there is insufficient bonding between layers in one or more test panel assemblies or adjusted downward if there is excessive (and undesired) “flattening” of surface features.

**[0111]** After the heated pressing of step 11, assembly 116 is “cold” pressed between room temperature press platens to continue to the bonding process and to enable melted bonding agent and/or other hot melt bonding material (e.g., TPU) to set while under pressure so as to improve bonding. As used herein, “room temperature” is a temperature between approximately 20° C. and approximately 30° C. By cold pressing assembly 116 immediately after the heated pressing of step 10, individual elements are held in contact while the melted bonding agent, hot melt bonding material, and skin layers solidify, thereby preventing materials rebounding from one another after the initial heated pressing. Without a subsequent cold pressing, for example, a skin layer element in at least some embodiments will not conform to an underlying mesh layer so as to show the mesh pattern on the outer side of the skin layer.

**[0112]** FIG. 4L shows cold pressing in step 12, which immediately follows step 11. After assembly 116 is removed from heated press platens 122 and 123 (FIG. 4K) and release paper 121 is taken off, assembly 116 is placed on silicone pad 129 between cold platens 130 and 131. A different silicone pad can be used in step 12 so as to avoid residual heat remaining in pad 120 at the completion of step 11. The same face of assembly 116 that faced silicone pad 120 in step 11 faces silicone pad 129 in step 12. In at least some embodiments, platen 130 and/or 131 may include internal water lines or another mechanism to maintain the platens at a desired temperature. Assembly 116 is then pressed between platens 130 and 131. Typical process parameters for the cold pressing operation of step 11 are room temperature (e.g., 25° C.) upper and lower press platens, press pressure of approximately 30 kg/cm<sup>2</sup>, and press time of approximately 30 seconds.

**[0113]** Heat-conductive silicone pads 120 and 129 used in steps 11 and 12, respectively, are at least partially compressible and conformable to the surface features of panel assembly 116. This permits compression of the panel assembly to bond the various layers without overly flattening the surface features. This also allows formation of a profile, such as is shown in region C of FIG. 3, in which skin material conforms to an underlying layer of mesh material so as to

reveal contours of that mesh material. In at least some embodiments, each of silicone pads **120** and **129** has a Shore-A hardness of between 15 to 30 and a thermal conductivity of approximately 0.3 Watts. However, pads with different thermal conductivities can be used by adjusting press platen temperatures to achieve a desired internal temperature in the pressed materials.

[0114] At the completion of step **12**, tacked assembly **116** has been transformed into a fused unibody shell that includes mesh composite panel **16** and foxing panel **17**. FIG. 5A shows fused unibody upper shell **116** that results from the completion of steps **1** through **12** of FIGS. 4A1-4L, and that is ready for finishing operations. Edges **133**, **134** and **135** are marked in FIG. 5A and will be further discussed below. In step **13** (FIG. 5B), tongue opening **26** is cut, extension tabs on the outer edges of composite panel **16** are trimmed away, and lacing eyelets punched. In step **14**, (FIG. 5C), skin layer element **36d** is applied by hot pressing combined with HF welding, but without a cold pressing step, so that skin layer element **36d** will have a different texture than other portions of upper **10**. In particular, a tool (not shown) having the shape of element **36d** is applied to unibody upper shell **116** on the location where panel **36d** is to be placed. HF welding heat is then applied through that tool to flatten the region of the mesh material in layer **28** under the tool. Element **36d** is then placed in the flattened region with an interposed layer of bonding agent, optionally tackified, or hot melt bonding material and HF welded in place using a heating element (e.g., formed from copper, brass, aluminum or other conductive material) in the shape of the desired melt pattern at a temperature, pressure and time appropriate for the materials in use. In some embodiments, element **36d** may be in the shape of a logo or other indicia that is associated with a manufacturer of the shoe, and a different texture for element **36d** may be desired to offset the logo from other portions of the shoe upper or for some other aesthetic purpose. In embodiments where a different texture for element **36d** is not desired, skin layer element **36d** can be added in a step inserted somewhere between steps **6** and **10** in the process flow of FIGS. 4A1-4L, and then hot- and cold-pressed with other elements when forming upper unibody shell **116**.

[0115] In step **15** (FIG. 5D), a foam element **140** with attached collar element **141** is placed onto a second jig **151** by inserting holes **152a** through **152i** over corresponding pins **153a** through **153i** on jig **151**. Collar element **141** forms a lip that overhangs an upper edge of foam element **140**. In some embodiments, collar element **141** can be formed from a folded-over section of material having an inverted “U” cross-section, with one leg of that “U” attached to the inside upper edge of foam element **140** and the other leg overhanging foam element **140** on the outside of that upper edge. Materials for foam element **140** can include open cell PU foam, and materials for collar element **141** can include synthetic suede. In step **16** (FIG. 5E), edge **134** of unibody upper shell **116** (see FIG. 5A) is inserted under the lip of collar element **141**. In step **17** (FIG. 5F), a copper HF welding tool (not shown) having a shape corresponding to collar element **141** (or to a portion of collar element **141**) is pressed onto collar element **141** and heat applied (at a temperature, pressure and time appropriate for the materials in use), thereby bonding shell **116**, foam element **140** and collar element **141** along the HF weld **153**.

[0116] In step **18** (FIG. 5G), regions of unibody upper shell **116** adjacent edges **133** and **135** (see FIG. 5A) are

joined to transform shell **116** into a three-dimensional upper shape. Prior to step **18**, extension tabs on collar **141** and excess portions of foam element **140** are trimmed. As part of step **18**, the portion of panel **16** that includes edge **135** is placed into a jig **160** having rails **161** and **162** that conform to the shape of panel **16** along edges adjacent to edge **135** and that hold shell **116** in place. The remainder of shell **116** (with attached foam element **140** and collar **141**) is then wrapped under and around the reverse side of jig **160** so as to place edge **133** over edge **135**. An HF welding tool (e.g., formed from copper or other conductive material) having a shape corresponding to the overlapped portions adjacent edges **133** and **135** is pressed onto folded-over panel **17** and heat applied (at a temperature, pressure and time appropriate for the materials in use), thereby bonding regions of shell **116** adjacent edges **133** and **135** along the HF weld **163**.

[0117] After completion of step **18**, the three-dimensional shell **116** (with attached collar **141** and foam element **140**) may undergo additional finishing prior to bonding to mid-sole **42** (FIGS. 1A and 1B). In some embodiments, the toe portion of mesh composite panel **16** is heated and applied to a shaping form so as to obtain a desired toe region shape. In some embodiments, the toe portion of the three-dimensional shell is heated to approximately 80° C. for approximately 20 seconds. The heated toe portion is then pressed onto a shaping die to obtain the proper toe shape, with vamp gathering then performed during a cooling step at approximately -4° C. for approximately 30 seconds. A plastic counter may be inserted between foxing panel **17** and foam **140** in the heel region and stitched or otherwise fastened in place. The tongue and/or a bootie or other type of liner is attached, and upper **11** is completed by stitching a Strobel in place around the lower edges of the upper panel while the upper is on a last.

[0118] Operations similar to those described above can be used to create a tongue for attachment to shell **116**. In particular, a tongue can also be formed by positioning one or more layers on jig, tacking those layers together, and then hot and cold pressing those layers to form a mesh composite panel in the shape of a tongue. The mesh composite of the tongue can have similar materials as are described above (e.g., a substrate, mesh and skin layers) or other combinations of materials. For example, a tongue composite panel can be formed to include a curved composite panel shaped to conform to the top of a wearer's foot and/or to include a padded element that is molded into a desired shape on the outer (or inner) side of the tongue composite. Elements for such a tongue composite could include a textile layer and a moldable foam padding layer. Instead of using a set of flat press platens such as is shown in FIGS. 4K and 4L, a pair of curved platens can be used to achieve the desired curvature for the tongue. One of those curved platens could further include a mold cavity that is used to form the padded element into the desired shape.

#### Additional Embodiments

[0119] Shoe **10** and the fabrication operations described above are merely examples of shoes and fabrication processes according to various embodiments. As indicated above, the shape and arrangement of a substrate layer, mesh layer and/or skin layer can vary in different embodiments, as can the number, size and arrangement of ventilation openings in a substrate. Moreover, different types of substrate materials, mesh materials and/or skin materials could be

employed for different shoe types. For example, a running shoe may utilize a mesh material that is lighter and/or has a different weave pattern than a mesh material used for a basketball shoe. Indeed, a single shoe could include more than one type substrate material and/or more than one type of mesh material and/or more than one type of skin material. In some embodiments, a skin layer might be omitted.

**[0120]** Certain embodiments may incorporate more than one type of mesh material in a single upper in various ways. For example, an upper according to some such embodiments may have a first type of mesh material in one portion of the upper and a second type of mesh material in a different portion. The first type of mesh may be of lighter weight and have larger openings so as to increase ventilation, and may be placed in locations that will correspond to portions of an upper that will be subject to less severe forces. The second type of mesh material may have a denser weave and/or be formed from a higher strength material, and may be placed in locations that will correspond to portions of an upper that will be subject to more severe forces. More than two types of mesh material can be used in an upper, and different mesh material types can be combined for other reasons (e.g., to achieve a desired aesthetic, to reduce unit cost, etc.).

**[0121]** Some embodiments can include uppers in which there may be multiple mesh layers.

**[0122]** In some cases, one mesh material panel may overlap another mesh material panel in an area where extra reinforcement is desired. In such embodiments, areas between overlapping mesh panels that also overlap the substrate layer are still considered mesh/substrate overlap areas, and such areas between overlapping mesh panels that are also overlapped by a skin layer are still considered skin/mesh/substrate overlap areas. In still other cases, separate mesh material panels may not overlap one another, and may be located at different layers of an upper. For example, a first panel of mesh material could be overlaid on a substrate material layer, a second panel of substrate material (or other type of material) overlaid onto a portion of the first panel, and a third panel of mesh material overlaid so as to overlap a portion of the second panel. In some embodiments, mesh material panels may be located at the same layer but not overlap one another.

**[0123]** Additional types of materials can be added to an upper shell in additional embodiments. Such additional materials can be included so as to form an outrigger, a shank, a heel cup, a toe cap, etc. For example, a panel of rigid nylon or other polymer could be included in the toe region of a composite panel and shaped as part of the toe shaping process described above. As another example, a counter panel formed from nylon or other type(s) of polymer could be included, during the process of assembling upper panels on an assembly jig, in a location that corresponds to the sides and rear of a wearer's heel in a completed shoe. Those counter panels can then be hot melt bonded to the inner side of panel 17 during the pressing operations.

**[0124]** FIGS. 6A, 6B, and 6C show examples of composite upper panel portions, according to some additional embodiments, that include an additional layer for reinforcement, support and/or padding, dimensional stability, etc. In FIG. 6A, a layer 201 of additional material is interposed between a layer 28' of mesh material and a layer 36' of skin material. The material of layer 201 is bonded to the skin material of layer 36' and to the layer of mesh material 28' with bonding agent or interposed layers of hot melt bonding

material (not shown). Bonding agent 39 is disposed between mesh layer 28' and substrate layer 27' (after having been selectively deposited between these layers 28'/27' as discussed above). In FIG. 6B, a layer 202 of additional material is located on an inner side of a substrate layer 27" and bonded to that substrate layer with an interposed layer of selectively deposited bonding agent 39, or otherwise an interposed layer of hot melt bonding material (not shown). A separate portion of bonding agent 39 is shown as disposed between substrate layer 27" and mesh layer 28". In FIG. 6C, a layer 203 of additional material is encapsulated between substrate layer 27" and mesh layer 28" in a location where mesh layer overlaps substrate layer 27" but where these layers are not bonded, allowing insertion of layer 203 to provide a quilted or other three-dimensional aesthetic effect. In this embodiment, bonding agent 39 is similarly disposed between substrate layer 27" and mesh layer 28". Material in layer 201, 202, or 203 could be the same material used in a substrate layer, could be a foam padding material, could be a plastic material that is rigid or semi-rigid, could be a rubber-like material, or could be a different type of material. Also shown in FIG. 6B are a mesh material layer 28" and a skin material layer 36". Examples of other materials that could be used for layer 201 or 202 to provide reinforcement and/or support include (but are not limited to) materials previously described herein and combinations thereof. Other materials that permit sufficient inter-layer bonding, have limited stretch and have appropriate heat-setting properties can also be used. Multiple layers of additional materials such as are shown for layers 201, 202, and 203 and/or combinations of materials (e.g., a foam panel and a rubber panel) could be employed. A composite panel having a construction such as indicated in FIGS. 6A, 6B, and 6C, as well as other types of composite panels having added reinforcement/support materials, can be fabricated using assembly, tacking and hot/cold pressing operations similar to those described herein.

**[0125]** In some embodiments, an upper shell formed according to the above described steps can include extensions in one or more panels (e.g., panel 17 of FIG. 4A1 et seq.) near regions that will correspond to the heel of a wearer. After completion of step 18 (FIG. 5G), the extensions can then be wrapped around the bottom of the heel region to form a double-lasted heel cup.

**[0126]** In certain embodiments, additional panels and/or panels having extensions can be included in a panel assembly so as to form a carrier layer for foam inserts. For example, such extensions can be included in regions of substrate material panels, foxing panels or other panels that can be wrapped under the bottom of a three-dimensional upper (after step 18 of FIG. 5G) so as to form a shelf for inclusion of foam padding that will cushion the bottom of a wearer's foot. Various types of foam materials can be used in these and other embodiments, including but not limited to foam materials as described in commonly-owned U.S. Pat. No. 7,941,938, issued May 17, 2011, and incorporated by reference herein. One example of a shoe comprising a double-lasted upper that forms a shelf for foam padding is described below in connection with FIGS. 10A through 16.

**[0127]** In some embodiments, and as shown in FIG. 7, a sole can include a toe cap extension 203. As indicated above, mesh material 28 can be omitted from the composite portion of a panel that corresponds to the region over which toe cap 203 will be located, thereby providing a smooth surface onto



which toe cap 203 could be bonded. Alternatively (or additionally), a reinforcing stitch 204 can be included to secure toe cap 203 in place. In still other embodiments, a toe cap can be formed by adding an additional layer of substrate material, a relatively thick layer of abrasion resistant plastic (e.g., polyurethane), or other material in the region that will correspond to the toe of the finished upper. In some such embodiments, mesh material is omitted in the toe region similar to the embodiment described in connection with FIGS. 4A1 through 5G, while in other embodiments the mesh material may extend over the entire toe region. In a similar manner, an additional layer of substrate material, a relatively thick layer of abrasion resistant plastic (e.g., polyurethane), a shock absorbing material (e.g., Phylon (compressed ethylene vinyl acetate foam)) or other material can be included in regions of an upper that will correspond to the lower heel and/or edges of a wearer foot in a finished shoe.

[10128] In at least some embodiments mesh material can also be omitted from portions of a composite panel that correspond to the regions where the upper will join a midsole. In this manner, a smoother transition from upper to midsole or other tooling can be achieved. Alternatively, a layer of foam or other moderator can be interposed between the lower edge of an upper and a midsole.

[10129] In some embodiments, a substrate material panel can be pre-processed so as to create an indentation in the form of a product name, a logo, or other shape. A skin layer material panel is then placed over the substrate material panel so as to completely cover the indentation and can be melted during the hot pressing operation so as to flow into and completely cover the indentation. The indentation can be created during a pre-processing operation using an HF welding tool having the desired shape, using laser cutting, or by other desired method. In certain embodiments, the skin layer panel used to cover the indentation may be thinner than skin layer panels used in other portions of an upper so as to create crisper and more defined edges of the covered indentation. Indentations can similarly be added to substrate material panels for other purposes. For example, indentations can be created to locate and/or accommodate harder materials used for reinforcement and protection in certain regions (e.g., for eye stay reinforcement, for heel counters, etc.). As another example, indentations can be created to locate and/or accommodate padding layers.

[10130] In certain embodiments, and as shown in FIG. 8, a layer of skin material is used to reinforce the transition from the mesh composite portion of a shell to another portion. FIG. 8 is a cross-section taken from the location shown in FIG. 1A. As seen in FIG. 8, the skin material of panel 36a extends over foxing panel 17.

[10131] In some embodiments, malleolus padding can be included in the region of the upper that will correspond to the portion of the wearer foot near the ankle. In some such embodiments, indentations are formed in the portions of foxing panel 17 (see FIG. 4A1 et seq.) that will correspond to the regions around the wearer ankles. These indentations can be formed, after step 12 of FIG. 4L, using an HF welding element in the shape of the desired padding. That element is applied to the inner side of panel 17, in the area that will correspond to the desired padding location, so as to create a pocket to contain the padding. Application of the HF element will also deform the outer side of foxing panel 17 in the shape of the padding element, thereby allowing the padding

presence to be visible in the finished upper. After creation of the padding pocket, the padding elements can be glued in place in the pockets, and an inner lining element of artificial suede applied over the inner side of the foxing panel to cover the padding elements. In some such embodiments, the padding element 140 (and steps 15-17 of FIGS. 5D through 5F) are omitted.

[10132] Various modifications can also be made to the above-described fabrication process in other embodiments. For example, different types of jigs or jig configurations can be used. In some embodiments, a jig with retractable pins can be employed to eliminate the need for a tacking operation (such as step 10 described above in connection with FIG. 4J). In some such embodiments, a heat-conductive jig with retractable pins is used to assemble elements of a shell and then placed face up onto a press having a heat-conductive silicone pad on an upper platen. Techniques other than pins can also be used to hold shell elements during assembly (e.g., a vacuum table, a static charge system, etc.).

[10133] In some embodiments, a dual pan assembly jig can be employed so as to avoid a tacking step. FIGS. 9A through 9C show use of a dual pan jig 450 according to some such embodiments. Jig 450 includes a lower pan 452 and an upper pan 453. Upper pan 453 includes a planar work surface 455 surrounded by a raised rim 456. Surface 455 includes a collection of through-holes, which holes are not visible in FIG. 9A, but which have locations corresponding to pins 454. Surface 455 also may have a non-stick coating. Pins 454, which are used to locate material panels of a panel assembly 316, are affixed to lower pan 452 and protrude through the holes in surface 455. So as to avoid confusing the drawings, all of pins 454 are not labeled. Lower pan 452 can be clipped or otherwise affixed to a planar work stand 451, with work stand 451 bolted or otherwise attached to a bench or other work location. For simplicity, panel assembly 316 is only shown generally in FIG. 9A. However, assembly 316 could be identical to assembly 116 described above (with pins 454 having relative locations identical to those of pins 101a-101g described above). The details of a panel assembly and pin layout will depend on a specific shoe design. In some embodiments, after a panel assembly layout pattern is developed for a specific upper, pins 454 are welded, soldered or braised to lower pan 452 in an appropriate pattern, and corresponding holes drilled in upper pan 453.

[10134] Material panels of assembly 316 are placed, and bonding agent 39 selectively deposited, in their proper locations on pins 454 in a manner similar to that described above in connection with FIGS. 4A1 through 4J, with the locations for individual panels identified by different groups of pins 454. If surface 455 does not have a non-stick coating, a layer of release paper can be placed onto surface 455 before placing panels of assembly 316. Instead of tacking the panels together as described in connection with FIG. 4J, a silicone pad 420 is placed over panel assembly 316 (FIG. 9B). Panel 420 is similar to panel 120 described above. Panel 420 has a shape that fits within rim 456 and is sufficiently thick to extend above rim 456.

[10135] While pad 420 rests over panel assembly 316, and as shown in FIG. 9C, upper pan 453 is pulled up and away from lower pan 452. Because pins 454 (FIG. 9A) are attached to lower pan 452, those pins remain on pan 452 as upper pan 453 is moved away. The weight of pad 420 on assembly 316 maintains the positions of the individual



panels of assembly 316 on surface 455 of pan 453, and thus a tacking operation can be omitted. Upper pan 453 (with assembly 316 and pad 420) can then be placed between heated press platens and hot pressing performed. In some embodiments, hot pressing time and/or press platen temperatures can be increased to account for heat absorption by pan 453. Pad 420 can be preheated prior to placement on upper pan 453. After hot pressing of assembly 316 in pan 453, assembly 316 can be removed from pan 453 and cold pressing performed, as described in connection with FIG. 4L, with a separate room temperature pad similar to pad 129 described above.

[0136] In some embodiments, an assembly process using jig 450 can be modified so that some or all of the assembled panels, and/or bonding agent between these assembled panels, are slightly tacky. This tackiness could prevent panels from slipping if pad 420 is moved after placement onto pan 453, but would allow removal and repositioning of panels during the assembly process. Panel tackiness can be achieved, e.g., by including small amounts of uncured bonding material on some panels. In still other embodiments, panel tackiness can be achieved by including heating elements on lower pan 452 that raise the temperature of pan 453 enough to begin the melting of the bonding agent, initially deposited as a powder, or the hot melt bonding materials (applied as a laminated layer or separate layer as described above) in a panel assembly. Such heating elements may also function to at least partially preheat upper pan 453 before the hot pressing operation.

[0137] The order of at least some steps can also be varied in some embodiments. In some embodiments, a tool used in an HF welding process (e.g., step 17 described above in connection with FIG. 5F) can include surface protrusions that emboss a manufacturer's logo or other indicia in the welded region.

[0138] As indicated above, some embodiments include upper shells that have extensions used for double-lasting and/or to provide a shelf to support foam padding. FIGS. 10A through 10E show assembly of individual material panels that will be used to create a one-piece, unibody upper shell for such an embodiment.

[0139] In FIG. 10A, a first panel 501 of substrate material is positioned on an assembly jig (not shown). For convenience, locating holes (such as holes 104b-104q in FIG. 4C) and locating hole extension tabs are not shown in FIGS. 10A-10E. However, the presence of such holes (and tabs, in some embodiments) is understood. For example, the assembly operations of FIGS. 10A through 10E can be carried out using an assembly jig such as jig 100 and the techniques described in connection with jig 100. Alternatively, the assembly operations of FIGS. 10A through 10E could be carried out using a dual-pan assembly jig such as jig 450 and the techniques described in connection with jig 450. Other jigs and techniques could also be used.

[0140] Panel 501 will form the inner layer of the upper shell being fabricated. Panel 501 can be formed, e.g., from a synthetic leather or other material from Table 1. Face 502 of panel 501 is visible in FIG. 10A. Face 502 will be the outer face of panel 501 in a completed shoe (i.e., face 502 will be oriented away from the shoe interior). In some embodiments, panel 501 may include a laminated layer of TPU or other heat-activatable bonding material on face 502. Otherwise, as discussed above, a bonding agent, may be deposited on panel 501 as a powder or tackified powder, in

fabricating an upper according to this embodiment. Unlike substrate panel 27 (FIG. 4C) described in connection with a previous embodiment, panel 501 will extend completely around a wearer foot in the completed shoe. For example, and as will be seen more clearly in connection with FIGS. 12-14, the flat unibody upper shell of which panel 501 will form a part does not include a separate foxing panel in the hindfoot region. Instead, panel 501 is a contiguous piece of substrate material. In a completed upper shell (and in the upper of the completed shoe including that shell), panel 501 includes portions located in lateral forefoot, lateral midfoot, top forefoot, medial forefoot, medial midfoot and hindfoot regions of the upper. The toe region of panel 501 includes a cutout 505 that will accommodate a toe cap.

[0141] As previously discussed, a wide variety of ventilation openings can be included in upper shells according to various embodiments. For example, instead of relatively large ventilation openings such as holes 31-34 in upper 11 of shoe 10 (see, e.g., FIGS. 1A, 1B and 4C), panel 501 includes a plurality of smaller ventilation holes 503. As another example, other embodiments could include large ventilation openings or a combination of large and small ventilation openings. Similarly, one or more ventilation openings in top forefoot region 504 could be included.

[0142] In FIG. 10B, a bonding agent 39, as a powder or tackified powder, is selectively deposited on substrate panel 501 in perimeter regions of overlap areas between substrate panel 501 and mesh panels that are subsequently placed in FIG. 10C. As shown, these perimeter regions encompass ventilation holes 503 (present in a central region of the overlap area). This reduces the total amount of material overlapping ventilation holes, relative to cases in which, for example, a layer of TPU or other bonding material is indiscriminately applied to the entire overlap areas, in order to bond with mesh panels. This reduction in material, specifically in the areas of ventilation holes 503, allows them to function more efficiently in providing "breathability" to finished upper.

[0143] In FIG. 10C, two mesh material panels 520 and 521 are placed onto substrate panel 501 so as to cover the ventilation holes 503 and the areas of substrate panel 501 that surround holes 503. These surrounding areas include the perimeter regions, in the area of overlap between mesh material panels 520 and 521, and substrate panel 501, in which bonding agent 39 was selectively deposited in FIG. 10B. In general, where panel 501 does not include a layer of TPU or other bonding material on face 502, a bonding agent, as a powder or tackified powder, can be interposed between substrate panel 501 and each of mesh material panels 520 and 521 in any part or all of the respective areas of overlap between substrate panel and mesh panel (i.e., mesh/substrate overlap areas). It is also possible for bonding agent or a separate layer of hot melt bonding material to be interposed between substrate panel 501 and each of mesh material panels 520 and 521. Panels 520 and 521 placed in FIG. 10C can, e.g., be cut from one of the materials identified in connection with Table 2 or otherwise identified as a possible mesh material in connection with other embodiments.

[0144] In FIG. 10D, a first skin material panel 524 is placed over mesh panels 520 and 521 and the region in between panels 520 and 521. Panel 524 also extends over much of the forefoot region of substrate panel 501. Panel 524, e.g., can be cut from a sheet of one of the possible skin materials previously mentioned in connection with other

embodiments. In some embodiments, that material may include a first layer formed from a TPU with a lower melting point and a second layer formed from a higher melting point TPU or from PU, with the first layer oriented toward face 502 of panel 501.

[0145] In FIG. 10E, reinforcement panels 527 and 528 are put into place. Panels 527 and 528 are in some embodiments cut from the same synthetic leather material used for panel 501. In other embodiments, panels 527 and 528 may be cut from materials that differ from the material of panel 501 (e.g., a different type of synthetic leather). Panels 527 and 528 need not be cut from the same type of material. For example, panel 527 could be cut from a first material and panel 528 could be cut from a second material, with that first material being different from that second material.

[0146] In the completed shoe, panel 528 will surround the rear of the wearer foot and includes an extension 506 that will extend over the lateral side of a wearer midfoot. Panel 528 further includes medial extension 507 that will surround an ankle opening on a medial side and a lateral extension 508 that will surround an ankle opening on a lateral side. Extensions 507 and 508 respectively include cutouts 509 and 510 that will ultimately create decorative contours in the exposed surface of a completed upper. Additional cutouts could be included in either or both of extensions 507 and 508 and/or in other portions of panel 528.

[0147] Panel 527 will extend over the arch region of a wearer foot in a completed shoe. Panels 529 and 530, which may be formed from nylon or other material, will serve as eye stay reinforcements in the completed shoe. The material (s) from which panels 527 and 528 are cut may include a laminated layer of TPU or other heat-activatable bonding material, which layer may then be oriented inward (e.g., toward face 502 of panel 501). In some embodiments (e.g., where panels 527 and 528 do not include such a layer of TPU or other bonding material), a bonding agent, as a powder or tackified powder, can be interposed between either or both of panels 527 and 528 and their underlying panel(s), including substrate panel 501. Bonding agent may be selectively deposited in part or all of the respective areas of overlap between these panels, in fabricating an upper according to this embodiment. It is also possible for a separate layer of hot melt bonding material to be interposed between substrate panel 501 and each of panels 527 and 528. Likewise, bonding agent can be selectively disposed between, or a separate layer of hot-melt bonding material can be placed between, skin panel 524 and each of eye stay reinforcement panels 529 and 530.

[0148] In FIG. 10F, three additional skin material panels 532-534 have been placed into position. As with panel 524, panels 532-534 can, e.g., be cut from a sheet of one of the possible skin materials previously mentioned in connection with other embodiments. As indicated above, that skin material can include a first layer formed from a TPU with a lower melting point and a second layer formed from a higher melting point TPU or from PU. The first layer of panels 532-533 could then be oriented inward, i.e., facing previously-placed panels. Panels 532-534 need not be cut from the same type of skin material. For example, panel 532 could be cut from a first skin material, panel 533 cut from a second skin material, and panel 534 cut from a third skin material, with each of those first, second and third skin materials being different from one another.

[0149] The assembly of panels from FIG. 10F is then subjected to hot and cold pressing as described above in connection with previous embodiments. At the conclusion of these pressing steps, the panel assembly from FIG. 10F is converted into a bonded composite panel 540 as shown in FIG. 11. As in previously-described embodiments, these pressing operations cause skin panels 532-534 to conform to underlying elements. As a result, outlines 551 and 552 of panels 527 and 528, respectively, are visible in skin panels 534 and 532, respectively. In a similar manner, the outlines 553 and 554 of eye stay reinforcing elements 529 and 530 are visible in skin panel 533. The patterns of mesh panels 520 and 521 are partially visible in regions 559 and 560 of skin panel 524.

[0150] FIG. 12 shows composite panel 540 after trimming. In particular, peripheral edges of panel 540 have been trimmed in multiple locations so as to provide an even edge and to remove excess material. A tongue opening 565 has been cut, and material has been removed so as to free the top and forward edges of lateral ankle tab 566. Lace eyelets 567 have been punched through panel 540 along the edges of tongue opening 565. Additional eyelets 568 have been punched through lateral ankle tab 566 and medial ankle tab 570.

[0151] FIG. 13 shows the inner face 600 of substrate panel 501 (and of trimmed composite panel 540). Regions 601a-601k on inner face 600 are respectively located adjacent to corresponding peripheral edge portions 602a-602k. In a three-dimensional upper shell formed from shell 540, and as seen in connection with FIG. 15A, regions 601a-601k will be part of extensions in a lower portion of that shell. As described below in connection with FIGS. 15A and 15B, the extension regions 601a-601k are bonded to a lower surface of a foam midsole in a later step.

[0152] Also marked in FIG. 13 is a region 571 of inner face 600. In the next step of forming an upper that will include panel 540, region 571 is bonded to region 572 on the outer face of panel 540 (FIG. 12). In particular, and in the embodiments described in connection with FIGS. 10A-16, trimmed panel 540 is a flat, unibody upper shell. Unlike certain previously-described embodiments, this flat unibody upper shell does not include a separate foxing panel in the hindfoot region. Regions 571 and 572 can be bonded by interposing hot melt bonding material between regions 571 and 572, by placing those regions into contact with one another, and by then applying pressure and heat. A jig similar to jig 160 (FIG. 5G) could be used.

[0153] In some embodiments, an ankle collar and/or padding can be added to panel 540 after trimming, but prior to bonding regions 571 and 572. The ankle collar (which could be located along edge 575 of panel 540) and the padding (which could be part of the ankle collar and/or located on the inside face of panel 540 below edge 575) could be added using techniques described in connection with previous embodiments.

[0154] FIG. 14 shows panel 540 after regions 571 and 572 have been bonded so as to convert panel 540 from a flat, unibody upper shell into a three-dimensional upper shell 540'. FIG. 14 further shows shell 540' placed onto a last L. Only a toe portion of last L and a last supporting bracket B are visible in FIG. 14. For simplicity, FIG. 14 does not show an ankle collar or features that could have been added in the hindfoot region of the shell 540' prior to placing of shell 540' onto last L. In some embodiments, shell 540' may undergo

additional finishing prior to placement onto last L. For example, shell 540' could be heated and applied to a shaping form so as to obtain a desired shape in certain regions.

[0155] Also shown in FIG. 14 is a foam midsole 610. The top side of midsole 610 is shown in FIG. 14. Stated differently, the side of midsole 14 seen in FIG. 14 will face toward a wearer foot in a completed shoe. In the embodiment of FIGS. 10A-16, midsole 610 is formed from one or more foam materials such as are described in the aforementioned U.S. Pat. No. 7,941,938. Midsole 610 includes a top surface 611 that is approximately contoured to conform to a wearer foot, as well as an edge wall 612 that extends above surface 611 and that surrounds the sides of a wearer foot to provide sideways support.

[0156] As part of assembling the shoe that will include shell 540' and midsole 610, midsole 610 is placed into shell 540' so that surface 611 contacts last L. This is represented by an arrow in FIG. 14. FIG. 15A shows midsole 610 after placement into shell 540' and onto last L. In FIG. 15A, the bottom surface 615 of midsole 610 is visible. The lower portions of shell 540' (including regions 601a-601k of inner face 600 and corresponding peripheral edge portions 602a-602k) extend beyond bottom surface 615. These extension portions of shell 540' form a skirt that extends out of the plane of FIG. 15A.

[0157] In a subsequent fabrication step, the extension portions of shell 540' are folded over and bonded to surface 615. In particular, an adhesive is applied to regions 601a-601k of inner face 600. A fabricator then sequentially pulls on lower portions of shell 540' so as to stretch shell 540' tightly against last L and, while maintaining tension on shell 540', presses those pulled lower portions against surface 615 so as to bond each of regions 601a-601k to surface 615.

[0158] FIG. 15B shows midsole 610 after the lower portions of shell 540' have been bonded to surface 615. Regions 601b through 601j become part of a shelf that supports midsole 610, and is located in a heel region. Regions 601b through 601j also form a double- lasted heel cup. Region 601a becomes part of the shelf supporting midsole 610 and is located in medial mid- and forefoot regions. Region 601k becomes part of the shelf supporting midsole 610 and is located in lateral mid- and forefoot regions.

[0159] In other embodiments, extension portions of an upper shell may not form a support shelf located in heel, medial mid- and forefoot, and lateral mid- and forefoot regions. For example, a shell in some embodiments may only include extensions that form a support shelf located in a heel region. As another example, a shell in other embodiments may only include extensions that form a support shelf located in heel and midfoot regions.

[0160] Ridge 616 extends above surface 615 and is used to position additional sole structure elements in subsequent steps. Ridge 616 also compensates for the thickness of the shell 540' portions bonded to surface 615. In particular, ridge 616 provides additional support in the central portion of the midsole 610 bottom surface that lack the presence of folded over shell 540' portions.

[0161] FIG. 16 shows a shoe 700 that includes shell 540' and bonded midsole (610 in FIG. 15B). In subsequent fabrication operations, a toe cap 630 is attached by adhesively bonding the outer edges of shell 540' near cutout 505 to inner edges of toe cap 630. A support plate 631 and outsole 632 are also attached. A tongue is attached to the interior of shell 540', and an insole may be inserted. A bootie

or other liner may also be attached, which liner may be a part of the tongue and attached as part of tongue attachment, and which liner may contain the insole. FIG. 16 also shows an ankle collar 635 that has been added to shell 540'.

[0162] In other embodiments that include upper shells with extensions used for double-lasting and/or to otherwise provide a shelf to support foam padding, numerous variations are possible. For example, fewer or more reinforcing panels can be used. The thicknesses, shapes, arrangements and other aspects of such reinforcing panels can be varied. Decorative features similar to those resulting from cutouts 509 and 510 can be achieved in additional ways. As but one example, a reinforcing panel can have reduced thickness in a certain area instead of a slot cut all the way through the panel. As another example, a small piece of material (e.g., in the shape of a logo) could be placed on an outer surface of a reinforcing panel so as to create an outline when skin material is later bonded to the reinforcing panel.

[0163] A bonded mesh composite panel used in an upper of a shoe such as that of FIGS. 1A and 1B (or of FIG. 16) offers numerous advantages. The composite panel includes substrate material in regions where support and protection for the wearer's foot is helpful, but can include relatively large openings in other areas. These openings help to reduce weight and to facilitate ventilation of the shoe interior. The mesh material provides tensile strength to bridge openings in the substrate layer and to augment the strength of the substrate layer in other areas. By bonding the mesh layer to the substrate layer over a wide area, seams along edges of the substrate ventilation openings can be avoided, thereby reducing the likelihood of tearing or separation along those ventilation hole edges. The skin layers can be used to provide abrasion resistance in various areas and/or to achieve desired aesthetic effects.

[0164] The above described fabrication processes for creating a bonded mesh composite panel also offer numerous advantages. Using the above-described processes, a relatively complex composite can be quickly formed in a simple manner using relatively simple equipment. Moreover, the above-described processes can also facilitate inexpensive changes to a composite panel design (for either functional or aesthetic reasons) without requiring substantial expensive re-tooling. The use of a bonding agent, applied as a powder or tackified powder, in only certain areas of overlap between panels, reduces material costs and material waste. Additional flexibility is also provided, in terms of the specific placement of bonding agent and the particular amount(s) and type(s) of bonding agent used.

[0165] The foregoing description of embodiments has been presented for purposes of illustration and description. The foregoing description is not intended to be exhaustive or to limit embodiments of the present invention to the precise form disclosed, and modifications and variations are possible in light of the above teachings or may be acquired from practice of various embodiments. As but one example, techniques such as are described herein can be used to fabricate articles other than footwear uppers. The embodiments discussed herein were chosen and described in order to explain the principles and the nature of various embodiments and their practical application to enable one skilled in the art to utilize the present invention in various embodiments and with various modifications as are suited to the

particular use contemplated. Any and all permutations of features from above-described embodiments are the within the scope of the invention.

1. A layered material structure comprising a bonded composite comprising:

- (a) a substrate layer and
- (b) at least one additional layer,

wherein a bonding agent is selectively disposed between the substrate layer and the additional layer.

2. The layered material structure of claim 1, wherein the layered material structure is an apparel item or a component thereof or a sporting goods item or a component thereof.

3. The layered material structure of claim 2, wherein the apparel item is selected from the group consisting of gloves, socks, a hat, a helmet, a jacket, and an item of skiwear, and wherein the sporting goods item is selected from the group consisting of a football, a basketball, a baseball, a volleyball, and a golf ball.

4. A method of fabricating a layered material structure comprising

- (a) selectively depositing a bonding agent, as a powder or a tackified powder, onto a substrate panel in one or more areas of overlap between the substrate panel and at least one additional panel,

- (b) positioning the additional panel onto the substrate panel, such that the bonding agent is selectively deposited between these panels in the one or more areas of overlap, and

- (c) compressing the substrate and mesh panels under bonding conditions suitable for forming the layered material structure.

5. The method of claim 4, wherein the bonding agent is selectively deposited as a tackified powder that is obtained by preheating the bonding agent, initially in powder form, on the substrate panel, prior to positioning the additional panel onto the substrate panel.

6. The method of claim 5, wherein the tackified powder is obtained by preheating the bonding agent using a laser, and a non-tackified portion of the bonding agent is removed, prior to positioning the additional panel.

7. The method of claim 4, wherein, in step (a), the bonding agent is selectively deposited as a powder, and wherein, during step (c), laser energy is applied at one or more locations to selectively activate the bonding agent.

8. The method of claim 7, further comprising (d) separating excess powder that is not activated by laser energy in step (c).

\* \* \* \* \*