



US 20140292341A1

(19) **United States**

(12) **Patent Application Publication**
Yang

(10) **Pub. No.: US 2014/0292341 A1**

(43) **Pub. Date: Oct. 2, 2014**

(54) **METHOD AND TOOL FOR DIRECTIONAL ELECTROMAGNETIC WELL LOGGING**

Publication Classification

(71) Applicant: **Jian Yang**, Sugar Land, TX (US)

(51) **Int. Cl.**
G01V 3/28 (2006.01)

(72) Inventor: **Jian Yang**, Sugar Land, TX (US)

(52) **U.S. Cl.**
CPC **G01V 3/28** (2013.01)
USPC **324/339**

(73) Assignee: **OLIDEN TECHNOLOGY L.L.C.**,
Sugar Land, TX (US)

(57) **ABSTRACT**

(21) Appl. No.: **14/061,572**

A directional antenna, system and method are provided. The methods include acquiring a plurality of data pairs, each data pair comprising an induced signal at a receiver and a corresponding toolface angle using a tool including at least one antenna assembly, as described herein. It further discloses a method to generate a measurement containing information about the directionality of the formation by calculating areas of an induced signal function approximated by the plurality of data pairs.

(22) Filed: **Oct. 23, 2013**

Related U.S. Application Data

(60) Provisional application No. 61/807,236, filed on Apr. 1, 2013.

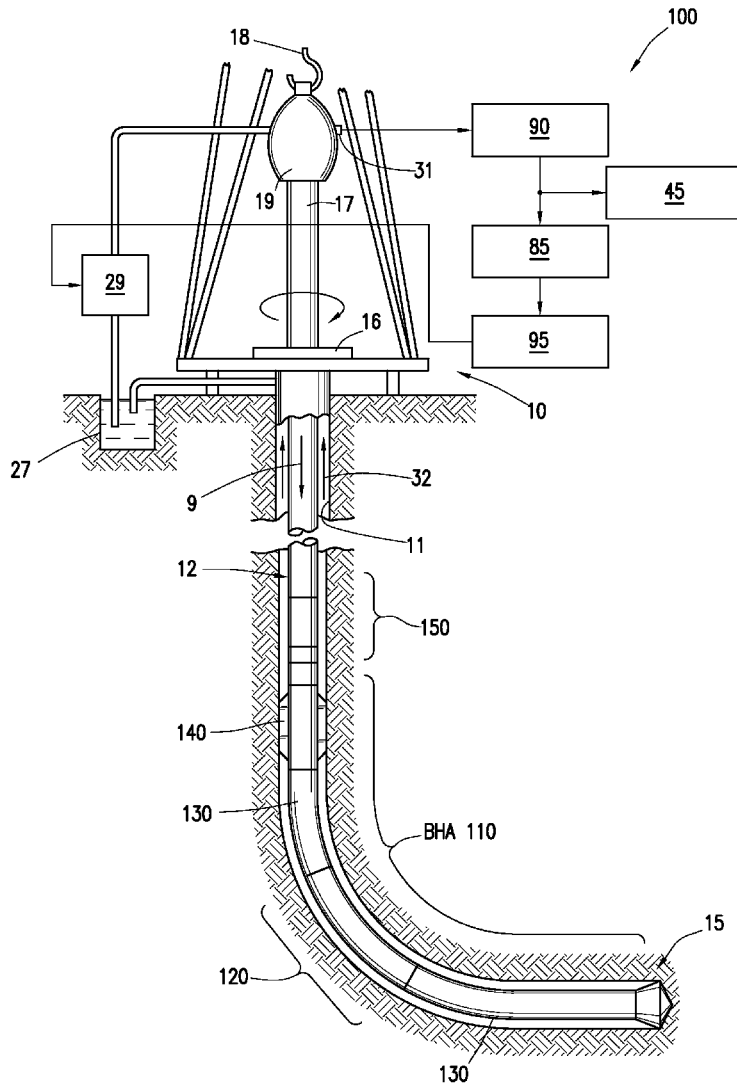

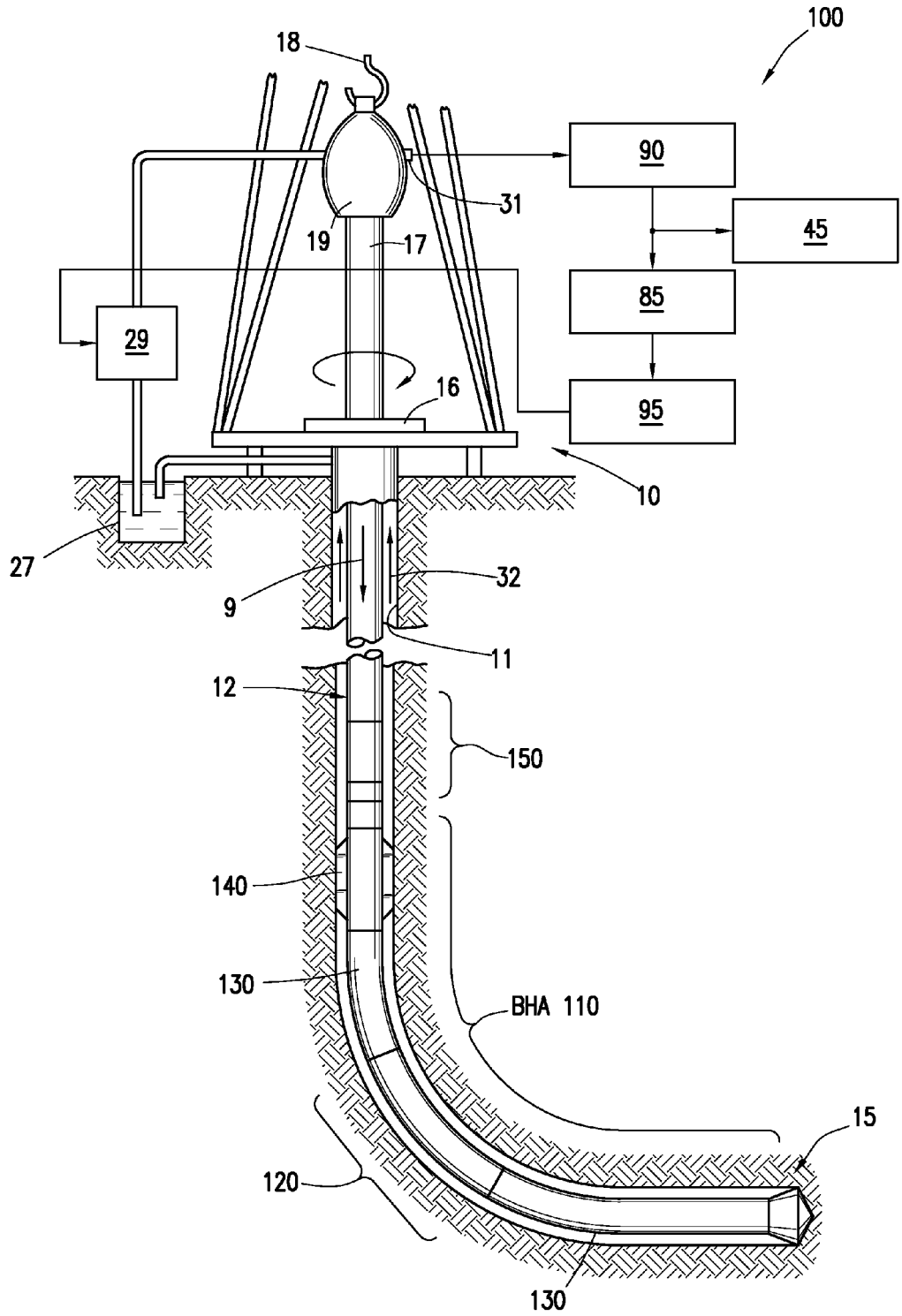

FIG. 1

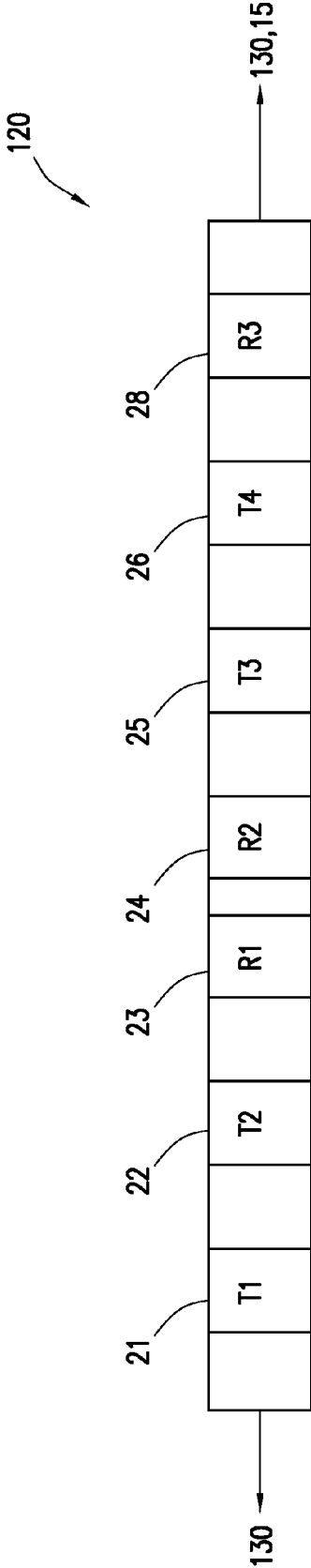

FIG. 2

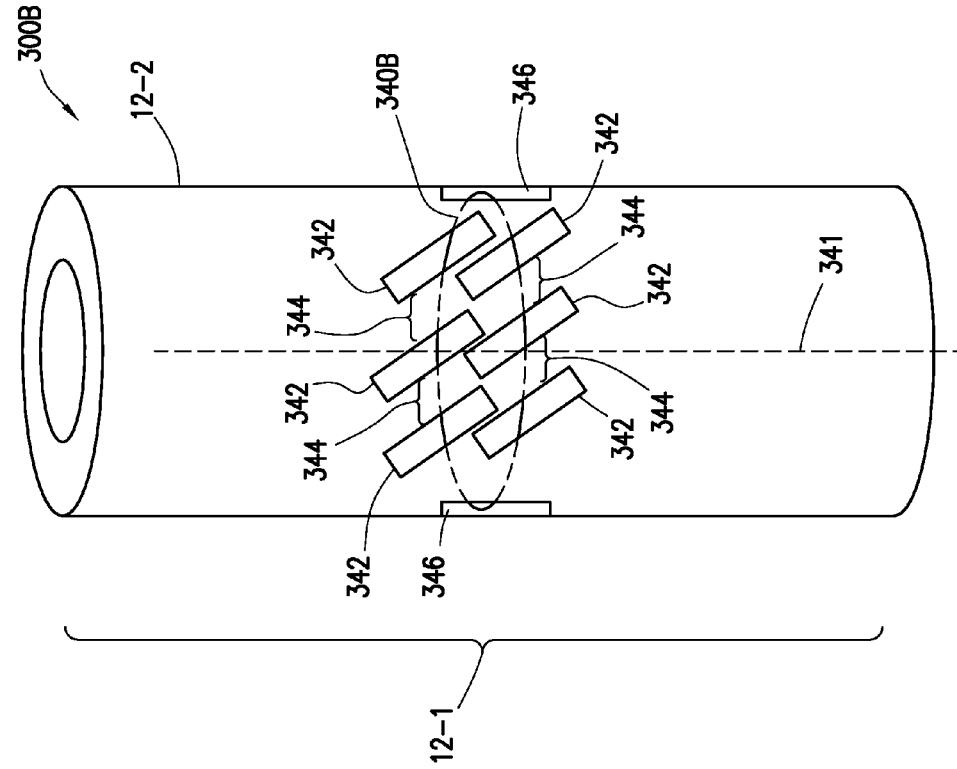

FIG. 3A

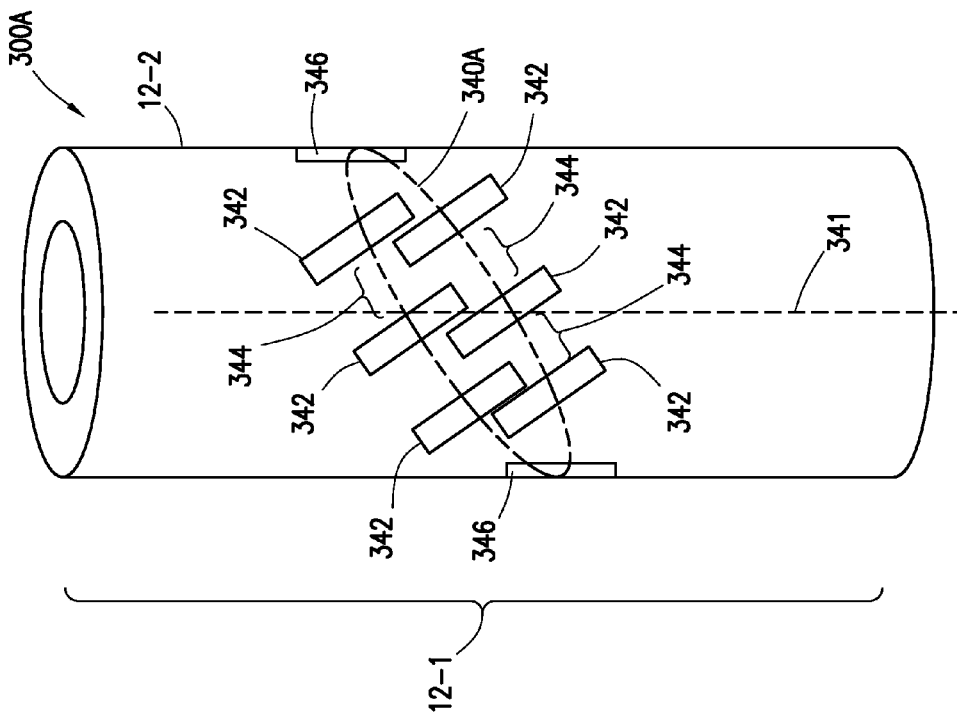

FIG. 3B

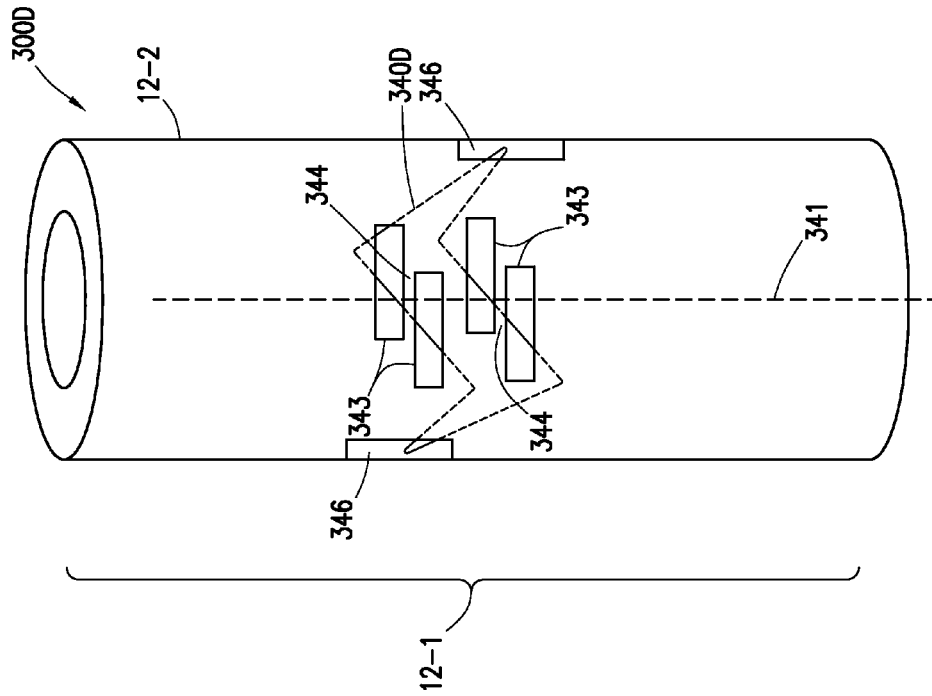

FIG. 3D

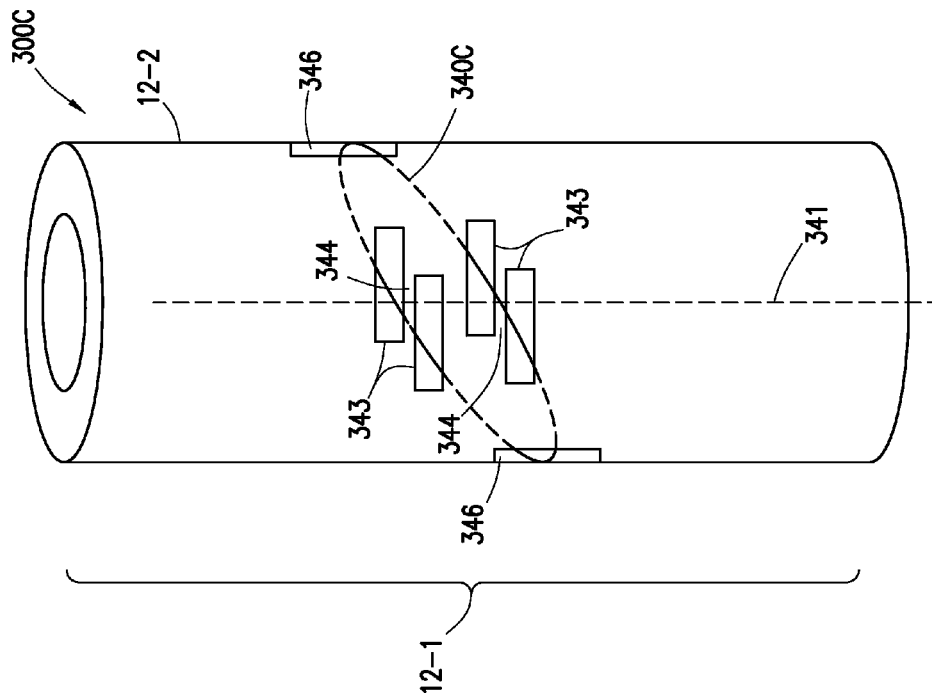
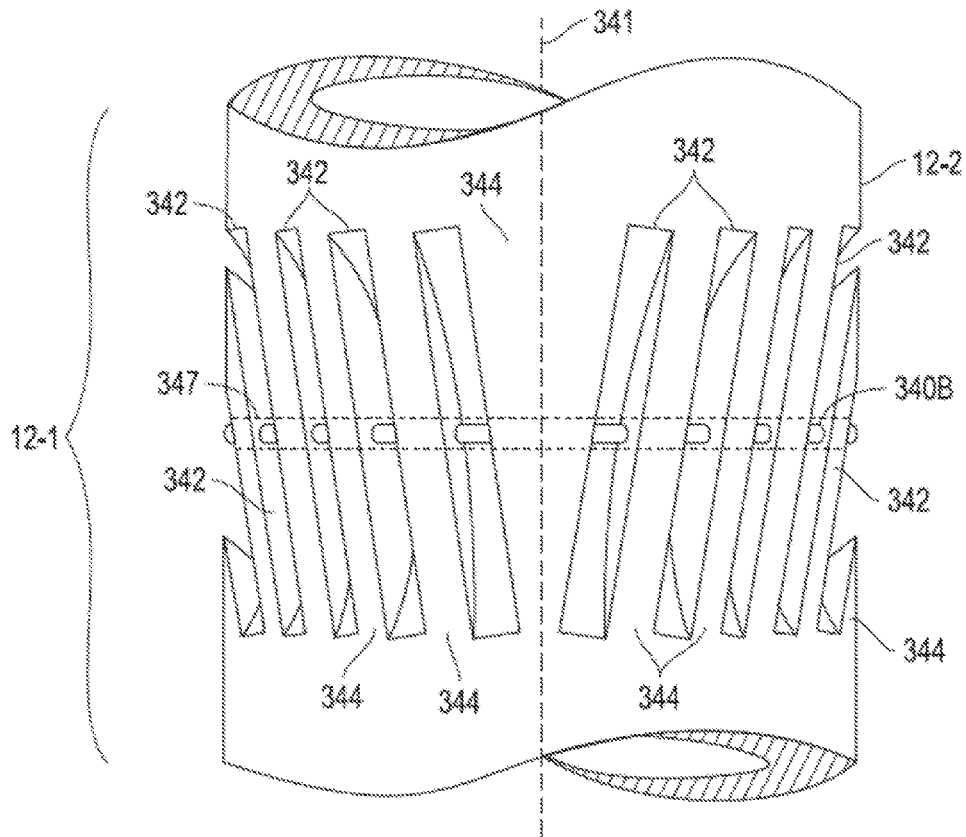

FIG. 3C

FIG. 3E



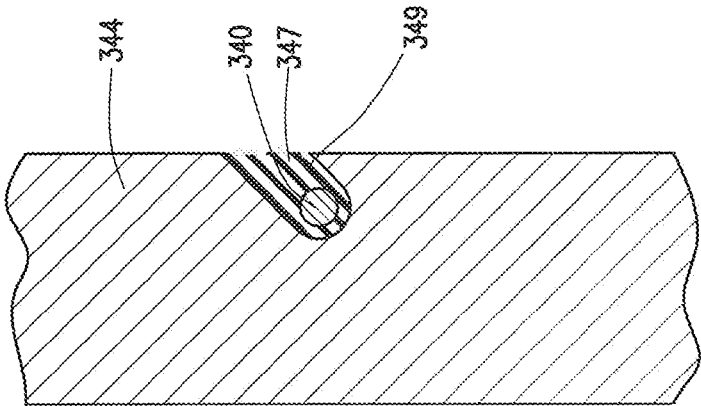

FIG. 3G

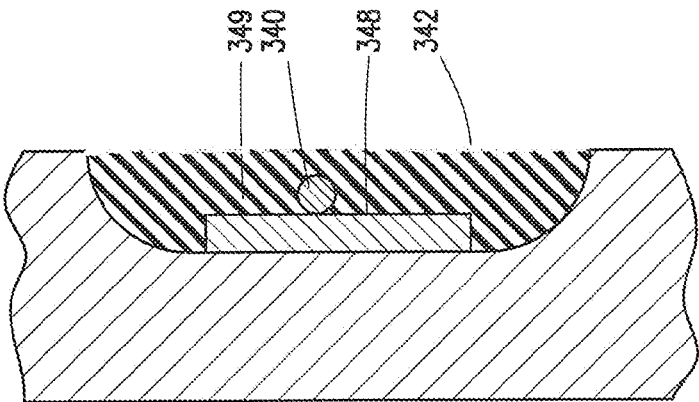

FIG. 3F

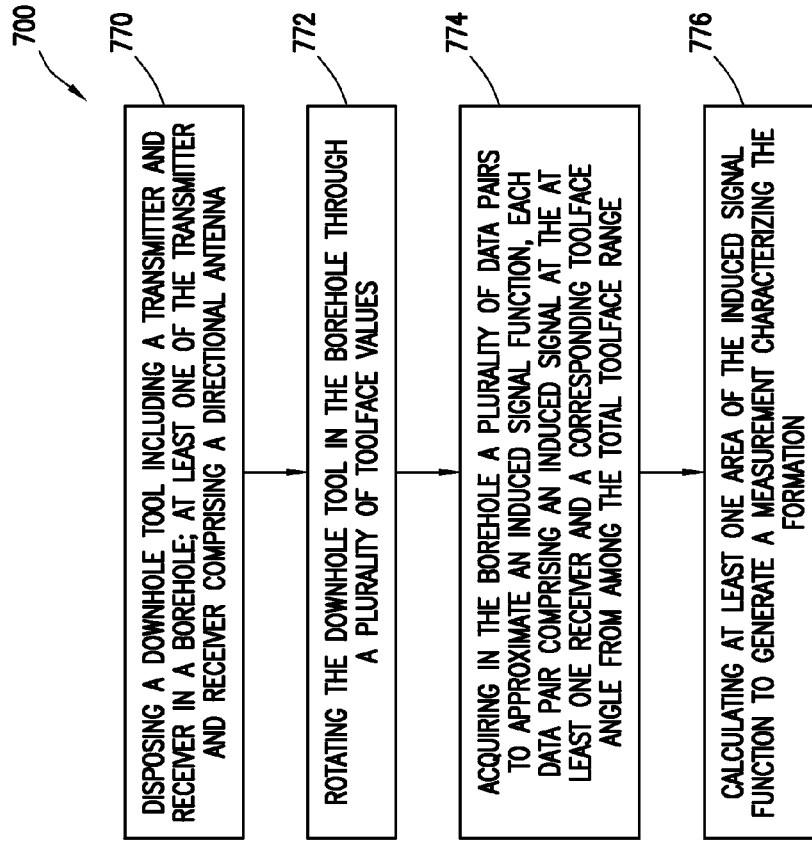

FIG. 7

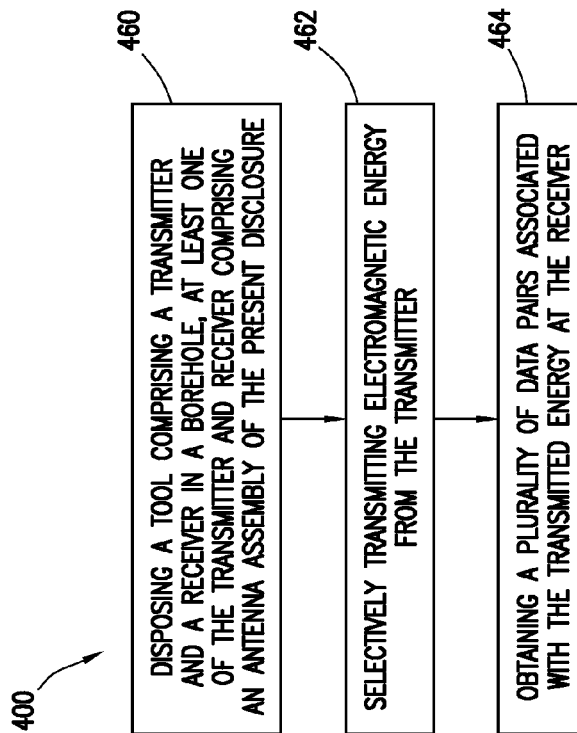

FIG. 4

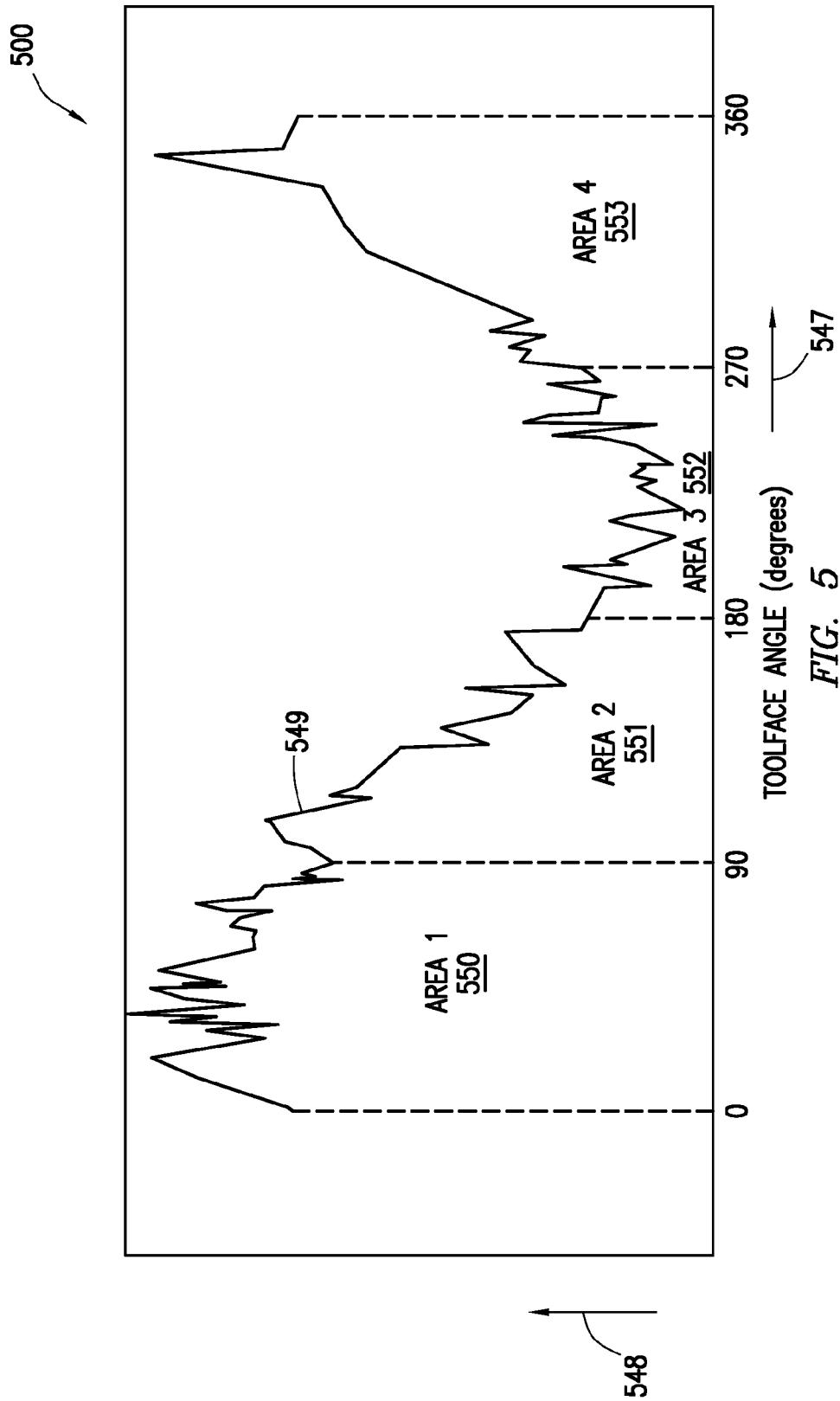
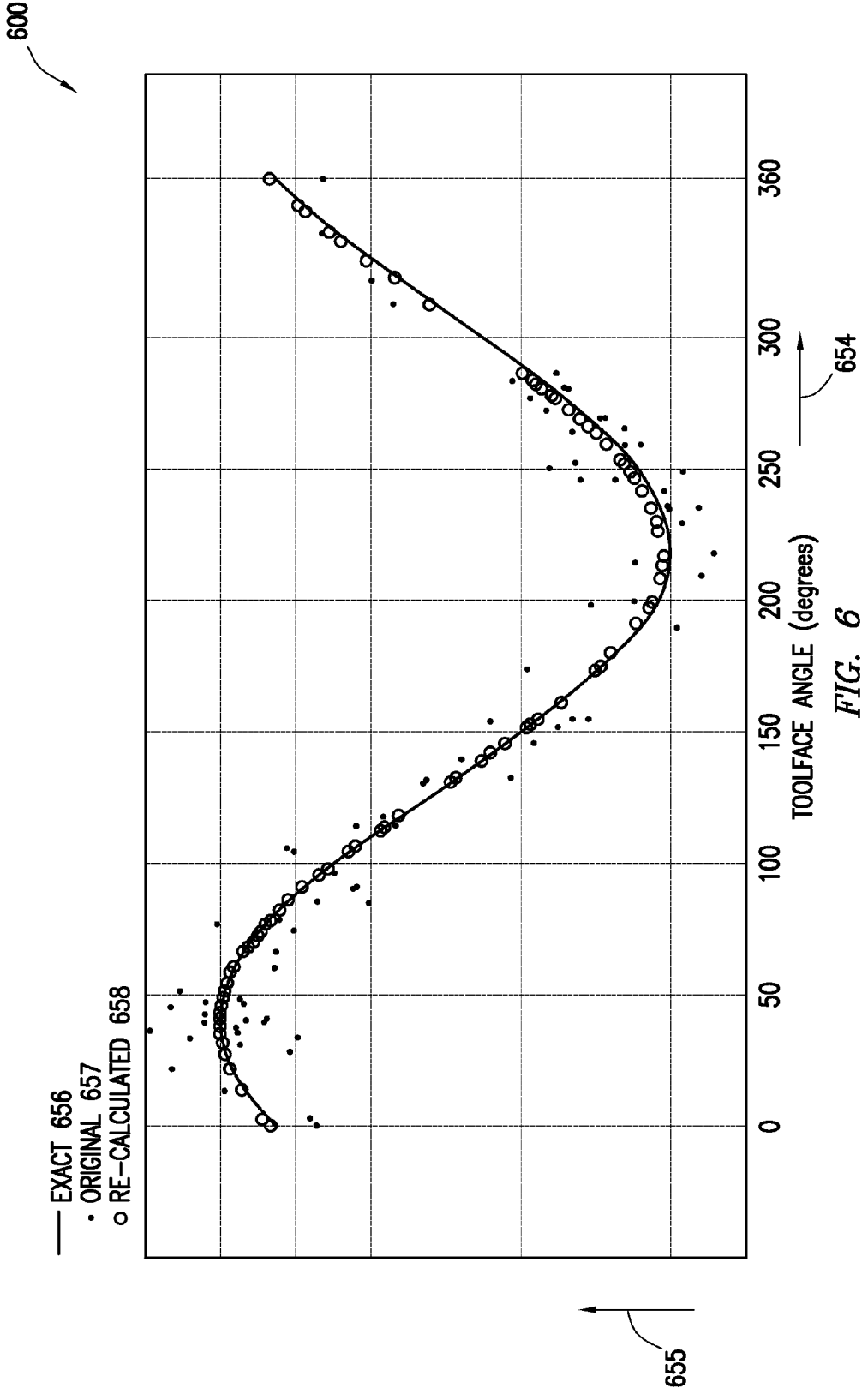

FIG. 5



METHOD AND TOOL FOR DIRECTIONAL ELECTROMAGNETIC WELL LOGGING

CROSS-REFERENCE TO RELATED APPLICATION

[0001] This application claims the benefit of U.S. Provisional Application No. 61/807,236, filed Apr. 1, 2013.

BACKGROUND

[0002] The present disclosure relates generally to the field of logging tools and particularly to electromagnetic logging tools. More specifically, the present disclosure relates to various directional antenna and tool designs, and methods for directional electromagnetic well logging while drilling.

[0003] Various well logging techniques are known in the field of hydrocarbon exploration and production. These techniques use instruments or tools equipped with transmitters adapted to emit energy into a subsurface formation that has been penetrated by a borehole. In this description, “instrument” and “tool” will be used interchangeably to indicate, for example, an electromagnetic instrument (or tool), a wire-line tool (or instrument), or a logging-while-drilling tool (or instrument). The emitted energy interacts with the surrounding formation to produce signals that are then detected and measured by one or more sensors. By processing the detected signal data, a profile of formation properties can be generated.

[0004] More specifically, electromagnetic logging tools including electromagnetic induction and wave propagation logging tools are used for determination of electrical properties of formations surrounding a borehole. Such logging tools obtain measurements relating to resistivity (or its inverse, conductivity) of the formation that, when interpreted, illustrate various petrophysical properties of the formation and fluids therein. The physical principles of electromagnetic induction resistivity well logging are well known.

[0005] Electromagnetic logging tools use transmitter and receiver antennas formed from an antenna coil, or a coil for short, formed of one or more turns of conductor wire, wound around a support. In some embodiments, such antennas may be operable as transmitter and/or receiver. Those skilled in the art will appreciate that an antenna may be used as a transmitter at one time and as a receiver at another. It will also be appreciated that the transmitter-receiver configurations disclosed herein are interchangeable due to the principle of reciprocity, i.e., the “transmitter” may be used as a “receiver”, and vice-versa.

[0006] Conventional electromagnetic logging tools employ non-directional transmitter and receiver antennas that do not have azimuthal sensitivity. In high angle or horizontal wells, measurements obtained with non-directional, antennas do not contain information about the directionality of the formation that allows distinguishing whether the borehole is approaching, e.g., a conductive layer from above or below. Such information is used in well placement applications. The logging tools comprising a directional antenna (an antenna having azimuthal sensitivity) such as those described in U.S. Pat. No. 5,508,616, U.S. Pat. No. 6,163,155, U.S. Pat. No. 6,476,609. Such logging tools can provide a directional measurement containing information about the directionality of the formation. It further provides more information used for various formation evaluation applications.

[0007] One challenge of logging-while-drilling electromagnetic logging tools is to protect the antenna coil in order

to withstand the demanding harsh downhole conditions. One design to protect the antenna known in prior art is to provide a portion of the collar as “necked-down”, by radially reducing the collar dimension to provide a deep and wide groove. The antenna coil is wound about the reduced radial dimension area of the collar, separated by an insulating layer from the surface of the reduced area, and a slotted sleeve or shield is provided and secured in position over the antenna coil. Various antenna designs of this type are described in U.S. Pat. No. 4,536,714, U.S. Pat. No. 4,949,045, U.S. Pat. No. 6,297,639, and U.S. Pat. No. 6,566,881.

[0008] Another design known in the prior art is to provide the antenna coil directly in a pathway within a drill collar having grooves through the thickness of drill collar, without the slotted shield disposed about the antenna coil found in the first method described. The antenna coil in the pathway exposed in the grooves is protected by a non-metallic material disposed in the grooves, and the antenna coil in the pathway between grooves is protected by the material of the drill collar through which the pathway passes. Various antenna designs of this type are described in U.S. Pat. No. 5,138,263, U.S. Pat. No. 5,530,358, U.S. Pat. No. 6,577,129, U.S. Pat. No. 7,057,392, U.S. Pat. No. 7,414,407, and U.S. Pat. No. 7,839,149.

[0009] Various processing methods for generating measurements from data collected by logging-while-drilling electromagnetic logging tools including a directional antenna are described in U.S. Pat. No. 7,382,135 and U.S. Pat. No. 8,195,400.

SUMMARY

[0010] In at least one aspect, the disclosure relates to a method. The method can include disposing a tool in a borehole disposed in a formation, the tool including at least one transmitter and at least one receiver. At least one of the transmitter and the receiver is a directional antenna. The transmitter and receiver are axially spaced relative to one another. The method can include acquiring in the borehole a plurality of data pairs, each data pair comprising a induced signal at the at least one receiver and a corresponding toolface angle from among a total toolface range. The method can include calculating at least one area of an induced signal function approximated by the plurality of data pairs to generate a measurement characterizing the formation.

[0011] In at least one aspect, the disclosure relates to a downhole measurement tool. The downhole measurement tool includes a tool body having a longitudinal axis. The downhole measurement tool includes at least one transmitting antenna deployed about the tool body. The downhole measurement tool includes at least one receiving antenna deployed about the tool body, the receiving antenna being axially spaced from the transmitting antenna. At least one of the transmitting antenna and the receiving antenna comprises a directional antenna. The downhole measurement tool includes a controller configured to (i) cause the tool to acquire a plurality of data pairs while rotating in a subterranean borehole, each data pair comprising an induced signal measurement and a corresponding toolface angle; and (ii) calculate downhole at least one area of an induced signal function approximated by the plurality of data pairs to generate a measurement characterizing the formation.

[0012] This summary is provided to introduce a selection of concepts that are further described below in the detailed description. This summary is not intended to identify key or

essential features of the claimed subject matter, nor is it intended to be used as an aid in limiting the scope of the claimed subject matter.

BRIEF DESCRIPTION OF THE DRAWINGS

[0013] Embodiments of antennas, tools, and methods for directional electromagnetic well logging are described with reference to the following figures. Like numbers are used throughout the figures to reference like features and components.

[0014] FIG. 1 is schematic of a drilling environment that may be used in connection with various implementations of the present disclosure.

[0015] FIG. 2 is a schematic drawing of an example electromagnetic logging tool in accordance with an embodiment of the present disclosure.

[0016] FIG. 3A-3E provide side views of various antenna assemblies in accordance with embodiments of the present disclosure, and FIG. 3F-3G show sectional views along the orientation of a groove and through a land, respectively.

[0017] FIG. 4 shows a flow chart of a method for acquiring data using an antenna assembly in accordance with the present disclosure.

[0018] FIG. 5 shows a plot of an induced signal function approximated by connecting discrete signal data points, as well as the four sub-sets of the area of the induced signal function, in accordance with an embodiment of the present invention.

[0019] FIG. 6 shows a plot of original simulated data points, re-calculated data points in accordance with an embodiment of the present invention, and the exact signal of a sinusoidal form.

[0020] FIG. 7 shows a flow chart of a method for processing data obtained in accordance with the present disclosure to generate measurements.

DEFINITIONS

[0021] As used here, the terms “up” and “down”; “upper” and “lower”; “upwardly” and “downwardly”; “below” and “above”; and other similar terms indicating relative positions above or below a given point or element may be used in connection with some implementations of various technologies described herein. However, when applied to equipment and methods for use in wells that are deviated or horizontal, or when applied to equipment and methods that when arranged in a well are in a deviated or horizontal orientation, such terms may refer to a left to right, right to left, or other relationships as appropriate, where “up” is the position in a toolstring relatively more proximal to surface equipment, and “down” is the position in the toolstring relatively more proximal to the bottom hole assembly.

[0022] “Axial” refers to a direction running substantially parallel to the longitudinal axis of a downhole tool or housing.

[0023] “Non-axial” refers to a direction running at some angle not parallel to the longitudinal axis of a downhole tool or housing, including angles orthogonal as well as some angle less than ninety degrees.

[0024] “Induced Signal Function” refers to a signal induced at a receiver of the tool by the electromagnetic wave emitted at a transmitter of the tool, as a function of the toolface angle. In an embodiment of the present disclosure, the induced signal is measured at a discrete time, and the induced signal

function is therefore approximately defined by a plurality of data pairs, each pair comprising an induced signal, and a corresponding toolface angle.

[0025] “Toolface angle” refers to the angular separation about the circumference of the tool from a given direction to the radial direction of a reference point on a downhole tool.

[0026] “Total toolface range” refers to the 360 degree range that covers a full or complete azimuthal rotation.

[0027] “Tool body section” refers to a portion of any tubular mechanical support that is adapted to be moveable through a borehole, the portion being substantially local to the position of the antenna coil disposed thereon, such as, for example, a portion of any of a drill collar, segment of drill pipe, tool housing, or other wellbore tubular, having an external surface and internal surface separated by a wall thickness, and the internal surface defining a central bore therethrough. The overall length of a tool may exceed the tool body section local to the coil.

[0028] “Antenna pathway” refers to, in one or more grooves, at least the space occupied by an antenna coil; and in one or more lands, the antenna pathway refers to at least a space through which an antenna coil may pass.

DETAILED DESCRIPTION

[0029] In the following description, numerous details are set forth to provide an understanding of the present disclosure. However, it will be understood by those skilled in the art that the present disclosure may be practiced without these details and that numerous variations or modifications from the described embodiments are possible.

[0030] The present disclosure describes various embodiments for antenna assemblies, each antenna coil being disposed about a tool body section in an antenna pathway. The antenna pathway passes through alternating lands (having a similar or substantially flush outer diameter as the tool body section) and grooves (having a reduced outer diameter relative to the tool body section, not passing completely through the thickness of the tool body section). In each embodiment, at least one of the grooves are disposed in the tool body section at a non-axial direction relative to the longitudinal axis of the tool body section, that is, not parallel to the longitudinal axis of the tool body section. In an embodiment, the antenna coil is an axial coil, where the axis of the coil is parallel to the axis of the tool body section, or a tilted coil, where the axis of the coil is not parallel to the axis of the tool body section. Additional grooves at axial angles or transverse angles may be disposed on the tool body section. Magnetic permeable material, such as ferrite, inserts may be disposed in the grooves. Each of the antenna assemblies disclosed may be employed in an electromagnetic logging tool for providing directional measurements while drilling.

[0031] The present disclosure also describes methods of acquiring a plurality of data pairs, each data pair comprising an induced signal at a receiver and a corresponding toolface angle using a tool including at least one directional antenna, such as a directional antenna assembly as described herein. It further discloses a method to generate a measurement containing information about the directionality of the formation by calculating at least one area of an induced signal function approximated by the plurality of data pairs.

Hardware

[0032] FIG. 1 illustrates a drilling environment **100** that may be used in connection with various implementations of

the present disclosures. In one implementation, the drilling environment **100** may include a drilling rig **10** positioned over a wellbore **11**. A drilling tool assembly, which may include a drill string **12** and a drill bit **15** coupled to the lower end of drill string **12**, may be disposed in wellbore **11**. Drill string **12** and bit **15** may be rotated by a kelly **17** coupled to the upper end of drill string **12**. The kelly **17** may be rotated by engagement with a rotary table **16** disposed on the rig **10**. The kelly **17** and the drill string **12** may be suspended by a hook **18** coupled to the kelly **17** by a rotatable swivel **19**.

[0033] Drilling fluid may be stored in a pit **27** and may be pumped through the center of drill string **12** by a mud pump **29** to flow downwardly (shown by arrow **9**). After circulation through bit **15**, the drilling fluid may circulate upwardly (indicated by arrow **32**) through an annular space between wellbore **11** and drill string **12**. Flow of the drilling mud may lubricate and cool bit **15** and lift drill cuttings made by bit **15** to the surface for collection and disposal.

[0034] A bottom hole assembly (BHA) **110** may be connected to drill string **12**. The bottom hole assembly **110** may include a stabilizer **140** and a drill collar **130**, which may be coupled to a local measuring device **120**. The bottom hole assembly **110** may also include a downhole communications system **150**, such as a pressure modulation (mud pulse) telemetry system. Pressure modulation telemetry can include various techniques for selectively modulating the flow (and consequently the pressure) of the drilling mud. The drill string **12** can also (or alternatively) comprise wired drill pipes that support high-speed telemetry between the surface and downhole tools.

[0035] A transducer **31** disposed at the earth's surface may be configured to detect pressure variations and to conduct signals to an uplink telemetry subsystem **90** for demodulation and interpretation. The demodulated signals may be forwarded to a processor **85** and a recorder **45** for further processing and/or storage. The surface equipment may optionally include a downlink telemetry subsystem **95**, which may include a pressure modulation transmitter (not detailed) that can modulate the pressure of the drilling mud circulating downwardly to communicate control signals to the bottom hole assembly **110**. It should be understood that the mud telemetry described above is one example of a communication means. Other telemetry systems known in the art may also be used.

[0036] The downhole communications system **150** may also include various types of processors and controllers (not shown) for controlling the operation of sensors disposed therein, for communicating command signals to the local measuring device **120**, and for receiving and processing measurements transmitted from the local measuring device **120**. Sensors in bottom hole assembly **110** and/or downhole communications system **150** may include magnetometers, accelerometers, gyrometers, and the like.

[0037] Various instruments disposed in the bottom hole assembly **110**, the downhole communications system **150**, and the local measuring device **120** may be referred to collectively as a logging-while-drilling (LWD) tool or measurement-while-drilling (MWD) tool. The bottom hole assembly **110**, the processor **85**, and/or the downhole communications system **150** may include various forms of data storage or memory that can store measurements made by any or all of the sensors, including sensors disposed in the local measuring device **120**, for later processing during or after the drill string **12** is withdrawn from wellbore **11**. In one implementation, the

LWD or MWD tool may be a propagation resistivity tool. As such, the bottom hole assembly **110**, the downhole communications system **150**, and the local measuring device **120** may be used to obtain well log data obtained from various transmitter-receiver pairs (to be discussed further below) and at multiple frequencies. Such data may be communicated to the surface while the LWD or MWD tool is downhole or stored in the LWD or MWD tool for later readout.

[0038] FIG. 2 is a block diagram of an example downhole tool for use as the local measuring device **120** of FIG. 1 in accordance with an embodiment of the present disclosure. Starting at left of FIG. 2, various antenna assemblies (one or more of which may be in accordance with antenna assemblies described herein) are provided along the local measuring device **120** shown. Each antenna assembly may function as a transmitter or receiver. At left, the local measuring device **120** is connected to the drill collar **130** as shown in FIG. 1. A first antenna assembly T1 **21** functions as a first transmitter. Adjacent to T1 **21** is positioned a second antenna assembly T2 **22**, functioning as a second transmitter. Axially spaced apart from T2 **22** are positioned one or more antenna assemblies. As shown, a third antenna assembly R1 **23** is positioned and is functional as a receiver, with a fourth antenna assembly R2 **24** functional as a receiver, coupled to a fifth antenna assembly T3 **25** functional as a transmitter. Axially spaced apart from T3 are positioned a sixth antenna assembly T4 **26** functional as a transmitter and a seventh antenna assembly R3 **28** functional as a receiver. At the right, the local measuring device **120** is connected to a next proximate section of drill collar **130** and on to the drill bit **15**.

[0039] As is well known, antenna assemblies in general may function as receiver, transmitter, or both, being referred to as a transceiver, and thus the example presented here is intended only as a representative example, and various other combinations of receivers, transmitters, and/or transceivers are presently contemplated. For example, the logging tool may be implemented with multiple modules, with one or more transmitter antenna assemblies deployed on one module, transmitting electromagnetic energy to be received by one or more receiver antenna assemblies deployed on a different module. The modules of the tool are removably joined to one another, or to an intervening module or set of modules, which may be other tools in the tool string. At least one of the transmitter and receiver antenna assemblies is in accordance with antenna assemblies described herein. Additional transmitters and/or receivers (not shown) may be provided adjacent to the antenna assemblies shown FIG. 2 as well.

[0040] In a particular embodiment of the downhole tool of FIG. 2, T1 **21** comprises a non-directional antenna, while T2 **22** comprises a directional antenna, such as one of the antenna assembly embodiments presented here. In an embodiment, R1 **23** comprises a non-directional antenna, R2 **24** comprises a non-directional antenna, and T3 **25** comprises a directional antenna, such as one of the antenna assembly embodiments presented here. In an embodiment, T4 **26** comprises a non-directional antenna, and R3 **28** comprises a directional antenna, such as one of the antenna assembly embodiments presented here. Optionally, additional transmitters and/or receivers may also be disposed in the local measuring device **120**, in various positions, and used in combination with the transmitters and receivers shown.

[0041] In a particular embodiment of the local measuring device **120** of FIG. 2, the spacing between adjacent antenna assemblies may range from about six (6) inches to about

eighteen (18) inches. In a particular embodiment of FIG. 2, the spacing between some adjacent antenna assemblies (21 and 22, 22 and 23, 24 and 25, 25 and 26, and 26 and 28) may be sixteen (16) inches, while the spacing between some adjacent antenna assemblies 23 and 24 (such as those used as receivers) may be about eight (8) to ten (10) inches. In other embodiments, the spacing between adjacent antenna assemblies may span larger or smaller distances.

[0042] FIG. 3A-3E provide side views of various directional antenna assemblies in accordance with embodiments of the present disclosure. In each of the embodiments of the antenna assembly, a tool body section 12-1 is provided, defined having a longitudinal axis 341 running length-wise. Turning to FIG. 3A, the tool body section 12-1 has an external surface 12-2, into which are disposed a plurality of grooves such as 342. Each of the grooves 342 has a reduced radial dimension relative to the external surface 12-2 of the tool body section 12-1. The grooves 342 are spaced around the tool body section 12-1. Between neighboring grooves 342, a land 344 is disposed, each land 344 having a radial dimension larger than that of each of the neighboring grooves and similar or substantially flush to that of the external surface 12-2 of the tool body section 12-1. In each embodiment described below, at least one of the grooves 342 is oriented at a non-axial direction with respect to the longitudinal axis 341 of the tool body section 12-1. An antenna pathway 347 (shown by dashed line in FIG. 3E) traverses the plurality of grooves 342 and plurality of lands 344 around the tool body section 12-1. The antenna pathway 347 passes through the lands 344, and a portion (or portions) of the space in each of the grooves that allows passage of a coil 340, which may comprise one or multiple turns, and may be non-planar.

[0043] FIG. 3A shows an embodiment of a first antenna assembly 300A, intended to show relative positioning of the grooves and coil. A tool body section 12-1 has an external surface 12-2, and having a longitudinal axis 341. Specifically, six grooves 342 and two grooves 346 are disposed in the external surface 12-2, shown here as rectangular, but may be of any geometrical shape such as quadrilateral or otherwise elongated in shape. Each groove 342, 346 is defined by two sides, a top and a bottom, which may be optionally rounded off. Each groove 342, 346 also has a depth, which may be a portion of the thickness of the tool body section 12-1. The depth may be, for example, uniform, graduated, or rounded. The orientation of each groove 342, 346 refers to the direction in which the groove 342, 346 is elongated. In the most simplified terms, each groove 342, 346 acts as a magnetic dipole oriented the same orientation as the elongation of the groove 342, 346, respectively.

[0044] As shown, the six grooves 342 are oriented at a non-axial direction relative to the longitudinal axis 341, while two grooves 346 are oriented in the axial direction relative to the longitudinal axis 341. A tilted coil 340A is positioned in an antenna pathway, passing through the alternating grooves 342 and grooves 346, where the coil is shown in solid curve, and lands 344, where the coil is shown in dashed curve. The antenna pathway can be formed by machining out a portion of each land 344, and subsequently welding each land 344 to the tool body section 12-1 before or after the coil(s) 340A are wound. The antenna pathway can also be formed by machining out a portion of each land 344, and subsequently covering the antenna coil with a cover part, preferably having similar electromagnetic properties to the material of the tool body section 12-1, over the coil for each land 344 after the coil

340A is wound. The addition of the cover part restores the overall radial dimension of the land. In one embodiment, the antenna pathway can also be formed by machining out a portion of each land 344, and subsequently filling each machined-out-portion with a non-metallic protective material, such as fiber glass or epoxy, to restore the overall dimension of the land after the coil 340A is wound. Alternatively, the antenna pathway may be drilled or punched through each land. In an embodiment, the antenna pathway in the lands 344 is preferably minimized to allow the antenna coil to pass therethrough without additional void space remaining around the antenna coil, and optionally, if void space is present, the void space may be sealed with a non-metallic filler, such as fiberglass or epoxy. In an embodiment, the non-axially oriented grooves 342 are oriented substantially perpendicular to the coil 340A.

[0045] In one embodiment, a non-metallic protective material, such as fiber glass or epoxy, is disposed in each groove when the coil 340A is in place, substantially filling the remaining space of the groove to a level flush with the external surface of each neighboring land 344.

[0046] In one embodiment, a magnetic permeable material insert (not shown in FIG. 3A) may be optionally disposed in each groove such that the insert is under the coil 340A when the coil 340A is placed about the tool body section 12-1. The magnetic permeable material may, for example, be a ferrite material.

[0047] In one embodiment, the two axial grooves 346 can be removed from FIG. 3A. On the other hand, the removal of non-axial grooves 342 or replacement of non-axial grooves 342 with axial grooves from FIG. 3A will result in a non-directional antenna assembly.

[0048] FIG. 3B shows an embodiment of a second antenna assembly 300B, intended to show relative positioning of the grooves and coil. A cylindrical tool body section 12-1 has an external surface 12-2, and has a longitudinal axis 341. Six grooves 342 and two grooves 346 are disposed in the external surface 12-2, shown here as rectangular, but may be of any geometrical shape such as quadrilateral or otherwise elongated in shape. Each groove 342, 346 is defined by two sides, a top and a bottom, which may be optionally rounded off. Each groove 342 also has a depth, which may be a portion of the thickness of the tool body section 12-1. The depth may be, for example, uniform, graduated, or rounded. The orientation of each groove 342, 346 refers to the direction in which the groove 342, 346 is elongated. In the most simplified terms, each groove 342, 346 acts as a magnetic dipole oriented the same orientation as the groove 342, 346. As shown, grooves 342 are oriented at a non-axial direction relative to the longitudinal axis 341, while two grooves 346 are oriented in the axial direction relative to the longitudinal axis 341. An axial coil 340B is positioned in an antenna pathway (not shown), passing through the alternating grooves 342, where the coil 340B is shown in solid curve, and lands 344, where the coil is shown in dashed curve. The non-axially oriented grooves 342 are oriented at an angle to the coil 340B.

[0049] As above, the antenna pathway can be formed by machining out a portion of each land 344, and subsequently welding each land 344 to the tool body section 12-1 before or after the coil(s) 340B are wound. The antenna pathway can also be formed by machining out a portion of each land 344, and subsequently covering the antenna coil with a cover part, preferably having similar electromagnetic properties to the material of the tool body section 12-1 over the coil for each

land 344 after the coil 340B is wound. The addition of the cover part restores the overall radial dimension of the land. In one embodiment, the antenna pathway can also be formed by machining out a portion of each land, and subsequently filling each machined-out-portion with a non-metallic protective material, such as fiber glass or epoxy, to restore the overall radial dimension of the land after the coil 340B is wound. Alternatively, the antenna pathway may be drilled or punched through each land. In an embodiment, the antenna pathway in the lands 344 is preferably minimized to allow the antenna coil to pass therethrough without additional void space remaining around the antenna coil, and optionally, if void space is present, the void space may be sealed with a non-metallic filler, such as fiberglass or epoxy.

[0050] In one embodiment, a non-metallic protective material, such as fiber glass or epoxy, is disposed in each groove when the coil 340B is in place, substantially filling the remaining space of the groove to a level flush with the external surface of each neighboring land 344. In one embodiment, a magnetic permeable material insert may be disposed in each groove such that the insert is under the coil 340B when the coil 340B is placed about the tool body section 12-1. The magnetic permeable material may, for example, be a ferrite material.

[0051] In one embodiment, the two axial grooves 346 can optionally be removed in FIG. 3B. On the other hand, the removal of non-axial grooves 342 or replacement of non-axial grooves 342 with axial grooves from FIG. 3B will result in a non-directional antenna assembly.

[0052] FIG. 3C shows an embodiment of a third antenna assembly 300C, intended to show relative positioning of the grooves and coil. A cylindrical tool body section 12-1 has an external surface 12-2, and has a longitudinal axis 341. Six grooves are disposed in the external surface 12-2, shown here as rectangular, but may be of any geometrical shape such as quadrilateral or otherwise elongated in shape. Each groove 343, 346 is defined by two sides, a top and a bottom, which may be optionally rounded off. Each groove 343, 346 also has a depth, which may be a portion of the thickness of the tool body section 12-1. The depth may be, for example, uniform, graduated, or rounded. The orientation of each groove 343, 346 refers to the direction in which the groove 343, 346 is elongated. In the most simplified terms, each groove 343, 346 acts as a magnetic dipole oriented the same orientation as the groove 343, 346. As shown, four of the grooves 343 are oriented orthogonally relative to the longitudinal axis 341. Two of the grooves 346 are oriented axially relative to the longitudinal axis 341. A tilted coil 340C is positioned in an antenna pathway, passing through the alternating grooves 342, where the coil is shown in solid curve, and lands 344, where the coil is shown in dashed curve.

[0053] As above, the antenna pathway can be formed by machining out a portion of each land 344, and subsequently welding each land 344 to the tool body section 12-1 before or after the coil(s) 340C are wound. The antenna pathway can also be formed by machining out a portion of each land 344, and subsequently covering the antenna coil with a cover part, preferably having similar electromagnetic properties to the material of the tool body section 12-1 over the coil for each land 344 after the coil 340C is wound. The addition of the cover part restores the overall radial dimension of the land. In one embodiment, the antenna pathway can also be formed by machining out a portion of each land 344, and subsequently filling each machined-out-portion with a non-metallic protec-

ive material, such as fiber glass or epoxy, to restore the overall radial dimension of the land after the coil 340C is wound. Alternatively, the antenna pathway may be drilled or punched through each land. In an embodiment, the antenna pathway in the lands 344 is preferably minimized to allow the antenna coil to pass therethrough without additional void space remaining around the antenna coil, and optionally, if void space is present, the void space may be sealed with a non-metallic filler, such as fiberglass or epoxy.

[0054] In one embodiment, a non-metallic protective material, such as fiber glass or epoxy, is disposed in each groove when the coil 340C is in place, substantially filling the remaining space of the groove to a level flush with the external surface of each neighboring land 344. In one embodiment, a magnetic permeable material insert may be disposed in each groove such that the insert is under the coil 340C when the coil 340C is placed about the tool body section 12-1. The magnetic permeable material may, for example, be a ferrite material.

[0055] In one embodiment, the two axial grooves 346 can be removed from FIG. 3C.

[0056] FIG. 3D shows an embodiment of a fourth antenna assembly 300D, intended to show relative positioning of the grooves and coil. A cylindrical tool body section 12-1 has an external surface 12-2, and has a longitudinal axis 341. Six grooves are disposed in the external surface 12-2, shown here as rectangular, but may be of any geometrical shape such as quadrilateral or otherwise elongated in shape. Each groove 343, 346 is defined by two sides, a top and a bottom, which may be optionally rounded off. Each groove 343, 346 also has a depth, which may be a portion of the thickness of the tool body section 12-1. The depth may be, for example, uniform, graduated, or rounded. The orientation of each groove 342, 346 refers to the direction in which the groove 342, 346 is elongated. In the most simplified terms, each groove 343, 346 acts as a magnetic dipole oriented the same orientation as the groove 343, 346.

[0057] As shown, four of the grooves 343 are oriented orthogonally relative to the longitudinal axis 341. Two of the grooves 346 are oriented axially relative to the longitudinal axis 341. A segmented coil 340D is positioned in an antenna pathway, passing through the alternating grooves 343 and 346. The antenna pathway can be formed by machining out a part from each land 344, and (optionally) by subsequently welding each land 344 to the tool body section 12-1 before or after the coil(s) 340A are wound, or other means.

[0058] As above, the antenna pathway can also be formed by machining out a portion of each land 344, and subsequently covering the antenna coil with a cover part, preferably having similar electromagnetic properties to the material of the tool body section 12-1 over the coil for each land 344 after the coil 340D is wound. The addition of the cover part restores the overall radial dimension of the land. In one embodiment, the antenna pathway can also be formed by machining out a portion of each land 344, and subsequently filling each machined-out-portion with a non-metallic protective material, such as fiber glass or epoxy, to restore the overall radial dimension of the land after the coil 340D is wound. Alternatively, the antenna pathway may be drilled or punched through each land. In an embodiment, the antenna pathway in the lands 344 is preferably minimized to allow the antenna coil to pass therethrough without additional void space remaining around the antenna coil, and optionally, if void

space is present, the void space may be sealed with a non-metallic filler, such as fiberglass or epoxy.

[0059] In one embodiment, a non-metallic protective material, such as fiber glass or epoxy, is disposed in each groove when the coil **340D** is in place, substantially filling the remaining space of the groove to a level flush with the external surface of each neighboring land **344**. In one embodiment, a magnetic permeable material insert may be disposed in each groove such that the insert is under the coil **340D** when the coil **340D** is placed about the tool body section **12-1**. The permeable material may, for example, be a ferrite material.

[0060] In one embodiment, the two axial grooves **346** can be removed from FIG. 3D.

[0061] FIG. 3E shows a side view of an antenna assembly in accordance with the embodiment shown in FIG. 3B. The external surface **12-2** of the tool body section **12-1** is shown. A plurality of grooves oriented at a non-axial direction are disposed around the external surface **12-2** of the tool body section **12-1**, with the grooves being defined by regions of reduced radial dimensions and alternating land members. The sides of each groove **342** appears having a flat surface in FIG. 3E, however, one of skill in the art would appreciate that depending on the details of the groove construction, either side of the groove may be represented by a curved surface. An antenna pathway **347** (outlined by the two dashed lines in FIG. 3E) is formed by machining out a portion of each land **344**. An axial antenna coil **340B** is positioned in the antenna pathway **347**, passing through the alternating grooves and lands. FIG. 3E illustrates clearly that the grooves orientation, being at a non-axial direction with respect to the longitudinal axis of the tool body section **12-1**, is clearly distinguished from a groove orientation running parallel with respect to the longitudinal axis **341** of the tool body section **12-1**.

[0062] In an embodiment, for example, not having axial grooves, but two sets of non-axial grooves, a land segment between the sets of non-axial grooves is present, which has different dimension than the lands that are between adjacent grooves in the same set. This is illustrated by the embodiment of FIG. 3E on a single tool body section **12-1**.

[0063] FIG. 3F is a sectional view through a single groove **342** with coil **340** passing therethrough, along the orientation of the groove **342**. A non-metallic protective material **349**, such as fiber glass or epoxy, is disposed in each groove filling the remaining space of the groove to a level substantially flush with the external surface of the neighboring lands. The coil **340** appears having a circular shape in FIG. 3F, however, one of skill in the art would appreciate that depending on the orientation of a particular groove **342** and/or the shape of wire of the coil **340** itself, the coil **340** may also be represented by an elliptical shape. Furthermore, the coil **340** appears having one turn of conductor wire in FIG. 3F, however, one of skill in the art would appreciate that the coil **340** may be formed of more than one turns of conductor wire.

[0064] As shown in the embodiment of FIG. 3F, a magnetic permeable material insert **348** may be disposed in each groove such that the insert **348** is under the coil **340** when the coil **340** is placed about the tool body section **12-1**. The magnetic permeable material may, for example, be a ferrite material.

[0065] FIG. 3G is a sectional view through a land **344** along the orientation of a neighboring groove **342**. The antenna passes through an antenna pathway **347**, which is formed by machining a portion out of the land **344**. In FIG. 3G, the sectional view of the antenna pathway **347** in the land **344**

appears sloped at an angle, however, one of skill in the art would appreciate that other embodiments with an antenna pathway formed in different orientations and shapes are possible. A non-metallic protective material **349**, such as fiber glass or epoxy, is disposed in any remaining space of the antenna pathway to a level substantially flush with the external surface of the land. The coil **340** appears having a circular shape in FIG. 3G, however, one of skill in the art would appreciate that depending on the orientation of the section of a particular land **344** and/or the shape of wire of the coil **340** itself, the coil **340** may also be represented by an elliptical shape. Furthermore, the antenna pathway **347**, as shown in the figure, is illustrated as formed by machining a single portion out of the land with the coil **340** having one turn of conductor wire disposed in it in FIG. 3G. However, one of skill in the art will appreciate that the antenna pathway may be formed by machining multiple portions out of the land, with adjacent portions axially spaced apart from one another, and with one or more turns of conductor wire disposed in each of the multiple portions of the antenna pathway.

Methods

[0066] Turning now to a discussion of methods carried out using the hardware described above, FIG. 4 shows a flow chart of a method for acquiring data using an antenna assembly in accordance with the present disclosure.

[0067] A method of acquiring data in a borehole formed in a formation includes disposing **460** a tool comprising at least one transmitter and at least one receiver in a borehole. At least one of the transmitter(s) or receiver(s) will be one of the antenna assembly embodiments disclosed herein and described with reference to FIG. 3A-3G, having at least one of the plurality of grooves in the tool body section being oriented at a non-axial direction with respect to the longitudinal axis of the tool body section. The method can include spacing the transmitter axially apart from the receiver, as described with respect to FIG. 2. The method can include azimuthally rotating the tool in the borehole, and for example, while drilling.

[0068] The method can include selectively **462** transmitting electromagnetic energy from the transmitter. The method can include obtaining **464** a plurality of data pairs associated with the transmitted energy at the receiver (which, upon processing, can generate a directional measurement). The method can optionally include using the directional measurement to alter (or alternatively, confirm) a drilling plan. The method can optionally include using the directional measurement to determine a direction to a formation boundary, a distance to the formation boundary, and/or relative resistivity on opposing sides of the formation boundary.

[0069] Turning now to a data processing method, a directional downhole tool (such as that shown in FIG. 2) comprises at least two antennas, one being a non-directional antenna and the other being a directional antenna such as those disclosed in the present disclosure. One antenna is used as a transmitter transmitting electromagnetic field at, e.g., 100 kHz, and or 400 kHz and or 2 MHz, and the other antenna is used as a receiver. The induced signal function $V(\phi)$ at the receiver can be written according to an equation of the form:

$$V(\phi) = V_0 + V_{1c} * \cos \phi + V_{1s} * \sin \phi \quad \text{Eq. (1)}$$

where ϕ is the toolface angle. In the real situation, it is a discrete function approximated by a plurality of data pairs, each pair comprising a induced signal at each discrete time,

and a corresponding toolface angle measured, for example, by a magnetometer, an accelerometer, or like device at the same time as the induced signal is measured. It is expected that within a short time interval V_0 , V_{1c} , and V_{1s} , which are termed 0^{th} and 1^{st} harmonic coefficients, that are in general linear combinations of various components of the induced magnetic fields, which are tensors, and contain information of the formation around the borehole, will remain relatively constant. During this time interval there can be a plurality of the induced signals and toolface angles measured. The present method is directed toward calculating coefficients V_0 , V_{1c} , and V_{1s} from the plurality of the data pairs, each pair comprising an induced signal, and a corresponding toolface angle.

The coefficients can be calculated based on the following mathematical equations:

$$V_0 = \frac{\int_0^{2\pi} V(\varphi) * d\varphi}{2\pi} \quad \text{Eq. (2a)}$$

$$V_{1c} = \frac{\int_0^{\frac{\pi}{2}} V(\varphi) * d\varphi + \int_{\frac{3\pi}{2}}^{2\pi} V(\varphi) * d\varphi - \int_{\frac{\pi}{2}}^{\frac{3\pi}{2}} V(\varphi) * d\varphi}{4} \quad \text{Eq. (2b)}$$

$$V_{1s} = \frac{\int_0^{\pi} V(\varphi) * d\varphi - \int_{\pi}^{2\pi} V(\varphi) * d\varphi}{4} \quad \text{Eq. (2c)}$$

[0070] Equations 2a, 2b, and 2d indicate that the area defined by the induced signal function across the total toolface range can be divided into a number of sub-sets (such as, for example, four sub-sets) according to toolface values, such as, for example: $[0, \pi/2]$, $[\pi/2, \pi]$, $[\pi, 3\pi/2]$, and $[3\pi/2, 2\pi]$. The signed areas of these sub-sets are referred to herein as Area1, Area2, Area3, and Area4. Coefficients V_0 , V_{1c} , and V_{1s} can then be obtained by calculating (such as, for example, by discrete integration) the areas of the sub-sets as follows:

$$V_0 = \frac{Area1 + Area2 + Area3 + Area4}{2\pi} \quad \text{Eq. (3a)}$$

$$V_{1c} = \frac{Area1 - Area2 - Area3 + Area4}{4} \quad \text{Eq. (3b)}$$

$$V_{1s} = \frac{Area1 + Area - Area3 - Area4}{4} \quad \text{Eq. (3c)}$$

[0071] FIG. 5 shows a plot 500 of an induced signal function approximated by a signal curve 549 by connecting discrete signal data points 548. The signal data points are original simulated with a random noise added to the exact induced signal function plotted as a curve 656 in FIG. 6. As many as four signal data points (at 0 , $\pi/2$, π , $3\pi/2$, and 2π) may be added, if not already presented in the original simulated data points, via interpolations. The area of the signal curve 549 can be divided based upon toolface angle into a number of sub-sets (in the example, four sub-sets 550, 551, 552, and 553 representing four sub-sets of toolface angles). The signed area, which will be simply referred to as "area" for short hereafter, for each sub-set can be calculated using an integra-

tion method, such as the trapezoidal method, to obtain the coefficients according to the mathematical equations above. With the coefficient values, one can combine the 0^{th} harmonic coefficient and the 1^{st} harmonic coefficients linearly to generate measurements used, for example, for well placement, or geosteering, and formation evaluation applications. Though four sub-sets of the induced signal function are shown in FIG. 5, it is also contemplated that fewer sub-sets or greater sub-sets could render a coefficient result useful for similar purposes.

[0072] FIG. 6 shows a plot 600 with original simulated signal data points, re-calculated signal data points in accordance with an embodiment of the present invention, and the exact signal which is a sinusoidal curve, shown for comparison. The re-calculated data points 658 are generated from Eq. (1) by using the calculated V_0 , V_{1c} , and V_{1s} from Eq. (3). As seen in the plot, the re-calculated data points are a more accurate representation of the exact signal than the original simulated data points. This demonstrates that the calculated V_0 , V_{1c} , and V_{1s} from Eq. (3) can provide an accurate representation of the exact signal.

[0073] If both transmitter and receiver are directional antennas such as those disclosed in the present invention above, Eq. (1) will need to be extended to add two second harmonic terms $V_{2c} * \cos(2\varphi) + V_{2s} * \sin(2\varphi)$, with V_{2c} and V_{2s} being termed 2^{nd} harmonic coefficients, which are in general linear combinations various components of the induced magnetic fields and contain information of the formation around the borehole. The method described above can be generalized to calculate the second harmonics coefficients. The area of the induced signal function is divided into 8 sub-sets according to the toolface angle: $[0, \pi/4]$, $[\pi/4, \pi/2]$, $[\pi/2, 3\pi/4]$, $[3\pi/4, \pi]$, $[\pi, 5\pi/4]$, $[5\pi/4, 3\pi/2]$, $[3\pi/2, 7/4\pi]$, and $[7/4\pi, 2\pi]$, and the area of each sub-set is referred to as Area1_1, Area1_2, Area2_1, Area2_2, Area3_1, Area3_2, Area4_1 and Area4_2. Then, accordingly, V_{2c} and V_{2s} can be calculated from the 8 areas of the sub-sets as follow:

$$V_{2c} = \frac{(Area1_1 - Area1_2 - Area2_1 + Area2_2 + Area3_1 - Area3_2 - Area4_1 + Area4_2)}{4} \quad \text{Eq. (4a)}$$

$$V_{2s} = \frac{(Area1_1 + Area1_2 - Area2_1 - Area2_2 + Area3_1 + Area3_2 - Area4_1 - Area4_2)}{4} \quad \text{Eq. (4b)}$$

[0074] As above, one can combine the 0^{th} harmonic coefficient, 1^{st} harmonic coefficients, and the 2^{nd} harmonic coefficients linearly to generate measurements, for example, for well placement and formation evaluation applications.

[0075] FIG. 7 shows a flow chart of a method 700 for processing data obtained in accordance with the present disclosure to produce measurements. The method for processing data can include disposing 770 a downhole tool in a borehole. In an embodiment, the downhole tool includes at least one transmitter and at least one receiver in a borehole disposed in a formation. At least one of the transmitter(s) and receiver(s) is a directional antenna. In an embodiment, at least one of the transmitter(s) and receiver(s) is an antenna assembly according to the present disclosure. The method continues with rotating 772 the downhole tool in the borehole through a plurality of toolface values.

[0076] The method can include acquiring **774** in the borehole a plurality of data pairs to approximate an induced signal function. In an embodiment, each data pair includes an induced signal at the at least one receiver and a corresponding toolface angle from among the total toolface range. One or more data pairs may be added via interpolation using some of the acquired data pairs so that the toolface angles span the total toolface range. The method can include calculating **776** at least one area of the induced signal function to generate a measurement characterizing the formation.

[0077] The method can include dividing the total toolface range into a plurality of sub-sets, and calculating, for each sub-set of the total toolface range, the area of the induced signal function to generate a measurement characterizing the formation.

[0078] In an embodiment, the plurality of sub-sets is four sub-sets. In an embodiment, the plurality of sub-sets is eight sub-sets. In an embodiment, the plurality of sub-sets span equal ranges of toolface angles.

[0079] The measurement includes a linear combination of the areas of the plurality of sub-sets of the induced signal function.

[0080] The measurement includes a magnitude ratio or a phase difference between two different linear combinations of the areas of the plurality of sub-sets of the induced signal function.

[0081] The measurement includes a 0^{th} harmonic coefficient of the induced signal, one or more 1^{st} harmonic coefficients of the induced signal, and one or more 2^{nd} harmonic coefficients of the induced signal.

[0082] In an embodiment, the calculating comprises a trapezoidal integration method.

[0083] In an embodiment, the method can include linearly combining a 0^{th} harmonic coefficient, one or more 1^{st} harmonic coefficients and, if determined, one or more 2^{nd} harmonic coefficients.

[0084] In an embodiment, the method can include a magnitude ratio or a phase difference between two different linear combinations of the 0^{th} harmonic coefficient, the 1^{st} harmonic coefficient and, if determined, the 2^{nd} harmonic coefficients.

[0085] The method can optionally include using the measurement characterizing the formation, for example, for geosteering and formation evaluation.

[0086] In an embodiment, the directional transmitter is selected from any of the antenna assembly designs described above with respect to FIG. 3A-3G. In an embodiment, the directional receiver is selected from any of the antenna assembly designs described above with respect to FIG. 3A-3G. In still another embodiment, both the transmitter and the receiver are selected from any of the antenna assembly designs described above with respect to FIG. 3A-3G.

[0087] Although a few example embodiments have been described in detail above, those skilled in the art will readily appreciate that many modifications are possible in the example embodiments without materially departing from this disclosure. Accordingly, such modifications are intended to be included within the scope of this disclosure as defined in the following claims. In the claims, means-plus-function clauses are intended to cover the structures described herein as performing the recited function and not simply structural equivalents, but also equivalent structures. Thus, although a nail and a screw may not be structural equivalents in that a nail employs a cylindrical surface to secure wooden parts together, whereas a screw employs a helical surface, in the

environment of fastening wooden parts, a nail and a screw may be equivalent structures. It is the express intention of the applicant not to invoke 35 U.S.C. §112, paragraph 6 for any limitations of any of the claims herein, except for those in which the claim expressly uses the words 'means for' together with an associated function.

What is claimed is:

1. A method, comprising:
 - disposing a tool in a borehole disposed in a formation comprising:
 - at least one transmitter and at least one receiver;
 - wherein at least one of the transmitter and the receiver is a directional antenna; and
 - wherein the transmitter and receiver are axially spaced relative to one another;
 - acquiring in the borehole a plurality of data pairs, each data pair comprising a induced signal at the at least one receiver and a corresponding toolface angle from among a total toolface range; and
 - calculating at least one area of an induced signal function approximated by the plurality of data pairs to generate a measurement characterizing the formation.
 2. The method according to claim 1, further comprising:
 - dividing the total toolface range into a plurality of sub-sets;
 - calculating, for each sub-set of the total toolface range, the area of the induced signal function to generate the measurement characterizing the formation.
 3. The method according to claim 1, wherein the plurality of sub-sets is four sub-sets.
 4. The method according to claim 1, wherein the plurality of sub-sets is eight sub-sets.
 5. The method according to claim 1, wherein the plurality of sub-sets span equal ranges of toolface angles.
 6. The method according to claim 1, wherein the measurement comprises one or more of:
 - a 0^{th} harmonic coefficient of the induced signal,
 - one or more 1^{st} harmonic coefficients of the induced signal, and
 - one or more 2^{nd} harmonic coefficients of the induced signal.
 7. The method according to claim 1, wherein the calculating comprises a discrete integration method.
 8. The method according to claim 7, wherein the discrete integration method comprises a trapezoidal integration method.
 9. The method according to claim 1, wherein the measurement further comprises a linear combination of one or more of the 0^{th} harmonic coefficient, the 1^{st} harmonic coefficient, and the 2^{nd} harmonic coefficient.
 10. The method according to claim 1, wherein the measurement further comprises a magnitude ratio or a phase difference between two different linear combinations of one or more of the 0^{th} harmonic coefficient, the 1^{st} harmonic coefficient, and the 2^{nd} harmonic coefficient.
 11. The method according to claim 1, wherein the measurement further comprises a linear combination of the areas of the plurality of sub-sets of the induced signal function.
 12. The method according to claim 1, wherein the measurement further comprises a magnitude ratio or a phase difference between two different linear combinations of the areas of the plurality of sub-sets of the induced signal function.
 13. The method according to claim 1, further comprising using the measurement characterizing the formation.

14. The method according to claim 1, wherein the at least one directional transmitter comprises:

- a tool body section with a longitudinal axis, the tool body section having an external surface comprising:
 - a plurality of grooves of reduced radial dimension spaced around the tool body section, each of the plurality of grooves being oriented at a non-axial direction with respect to the longitudinal axis of the tool body section;
 - a plurality of lands spaced around the tool body section, each land of the plurality of lands separating at least two adjacent grooves of the plurality of grooves;
- an antenna pathway traversing the plurality of grooves and plurality of lands around the tool body section; and
- a coil disposed in the antenna pathway.

15. The method according to claim 1, wherein the at least one axially spaced directional receiver comprises:

- a tool body section with a longitudinal axis, the tool body section having an external surface comprising:
 - a plurality of grooves of reduced radial dimension spaced around the tool body section, each of the plurality of grooves being oriented at a non-axial direction with respect to the longitudinal axis of the tool body section;
 - a plurality of lands spaced around the tool body section, each land of the plurality of lands separating at least two adjacent grooves of the plurality of grooves;
- an antenna pathway traversing the plurality of grooves and plurality of lands around the tool body section; and
- a coil disposed in the antenna pathway.

16. A downhole measurement tool, comprising:

- at least one transmitter;
- at least one receiver;
- wherein at least one of the transmitting antenna and the receiving antenna comprises a directional antenna; and
- a controller configured to (i) cause the tool to acquire a plurality of data pairs while rotating in a subterranean borehole, each data pair comprising an induced signal and a corresponding toolface angle from among a total toolface range; and (ii) calculate downhole at least one area of an induced signal function approximated by the plurality of data pairs to generate a measurement characterizing the formation.

17. The downhole measurement tool of claim 16, wherein the controller is further configured to divide the total toolface range into a plurality of sub-sets; and calculate, for each

sub-set of the total toolface range, the area of the induced signal function to generate a measurement characterizing the formation.

18. The downhole measurement tool of claim 17, wherein the plurality of sub-sets is four sub-sets.

19. The downhole measurement tool of claim 17, wherein the plurality of sub-sets is eight sub-sets.

20. The downhole measurement tool of claim 17, wherein the plurality of sub-sets span equal ranges of toolface angles.

21. The downhole measurement tool of claim 16, the controller being further configured to output the measurement comprising one or more of: a 0^{th} harmonic coefficient of the induced signal, one or more 1^{st} harmonic coefficients of the induced signal, and one or more 2^{nd} harmonic coefficients of the induced signal.

22. The downhole measurement tool of claim 16, the controller being further configured to apply a discrete integration method.

23. The downhole measurement tool of claim 16, the controller being further configured to output the measurement comprising a linear combination of one or more of the 0^{th} harmonic coefficient, the 1^{st} harmonic coefficient and the 2^{nd} harmonic coefficient.

24. The downhole measurement tool of claim 16, the controller being further configured to output the measurement comprising a magnitude ratio or a phase difference between two different linear combinations of one or more of the 0^{th} harmonic coefficient, the 1^{st} harmonic coefficient, and the 2^{nd} harmonic coefficient.

25. The downhole measurement tool of claim 16, the controller being further configured to output the measurement comprising a linear combination of the areas of the plurality of sub-sets of the induced signal function.

26. The downhole measurement tool of claim 16, the controller being further configured to output the measurement comprising a magnitude ratio or a phase difference between two different linear combinations of the areas of the plurality of sub-sets of the induced signal function.

27. The downhole measurement tool of claim 16, the controller being further configured to transfer to the surface the measurement characterizing the formation.

28. The downhole measurement tool of claim 16, wherein the transmitter and the receiver are deployed on a single tool module.

29. The downhole measurement tool of claim 16, wherein the transmitter and the receiver are deployed on more than one separable tool modules.

* * * * *