



US 20240136703A1

(19) **United States**

(12) **Patent Application Publication**  
**JUNG et al.**

(10) **Pub. No.: US 2024/0136703 A1**

(43) **Pub. Date: Apr. 25, 2024**

(54) **ANTENNA MODULE AND ELECTRONIC DEVICE COMPRISING SAME**

**Publication Classification**

(71) Applicant: **Samsung Electronics Co., Ltd.**,  
Gyeonggi-do (KR)

(51) **Int. Cl.**  
*H01Q 1/24* (2006.01)  
*H01Q 1/38* (2006.01)  
*H01Q 21/00* (2006.01)

(72) Inventors: **Dongjin JUNG**, Gyeonggi-do (KR);  
**Chanju PARK**, Gyeonggi-do (KR);  
**Jungi JEONG**, Gyeonggi-do (KR);  
**Taeksun KWON**, Gyeonggi-do (KR);  
**Jungwoo SEO**, Gyeonggi-do (KR);  
**Junhwa OH**, Gyeonggi-do (KR)

(52) **U.S. Cl.**  
CPC ..... *H01Q 1/243* (2013.01); *H01Q 1/38*  
(2013.01); *H01Q 21/0075* (2013.01)

(21) Appl. No.: **18/547,977**

(57) **ABSTRACT**

(22) PCT Filed: **Apr. 27, 2022**

An antenna module, according to various embodiments, may comprise: a first layer including a first etching region, a first via pad disposed to be spaced apart from an edge of the first etching region, and a first via hole disposed on one surface of the first via pad; and a second layer stacked on one surface of the first layer, and including a second etching region, a plurality of second via pads disposed to be spaced apart from an edge of the second etching region, a plurality of second via holes disposed on one surface of the plurality of second via pads, and a plurality of second dividing lines electrically connecting the plurality of second via pads.

(86) PCT No.: **PCT/KR2022/006082**

§ 371 (c)(1),

(2) Date: **Aug. 24, 2023**

(30) **Foreign Application Priority Data**

May 24, 2021 (KR) ..... 10-2021-0066644

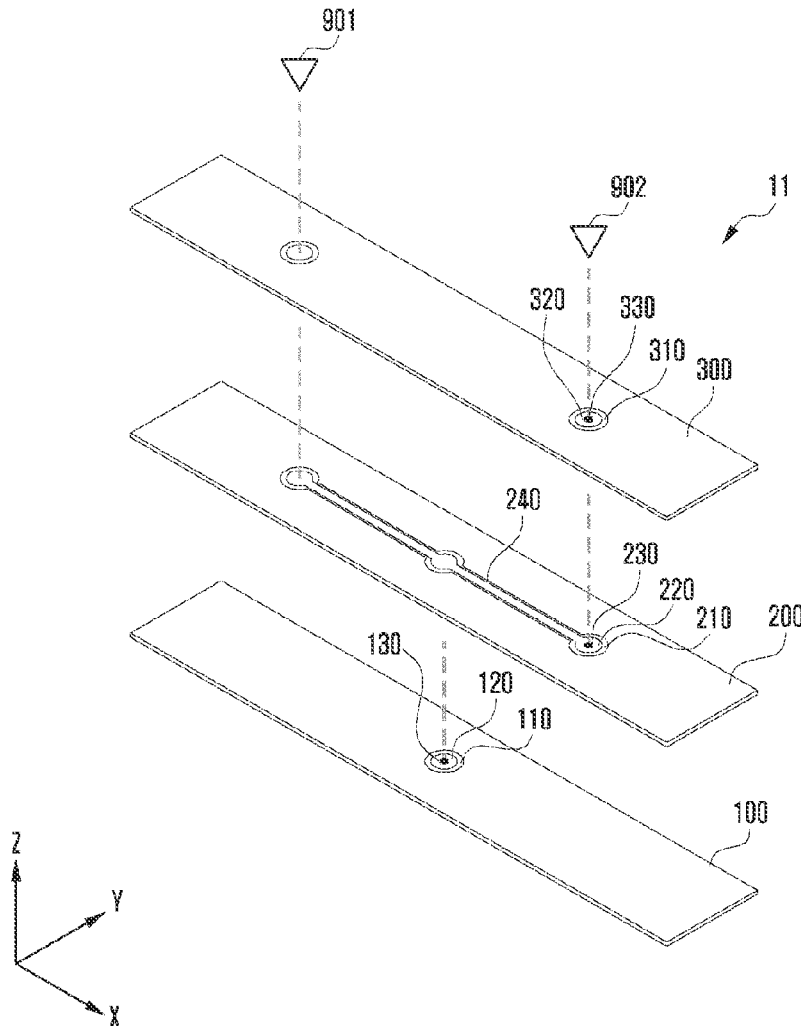

FIG. 1

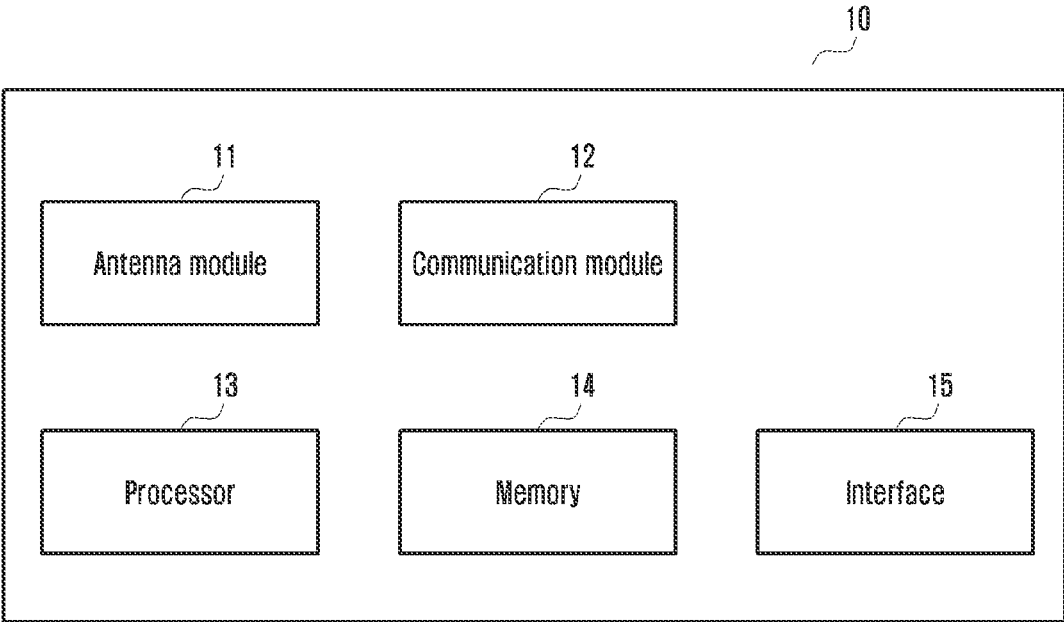

FIG. 2

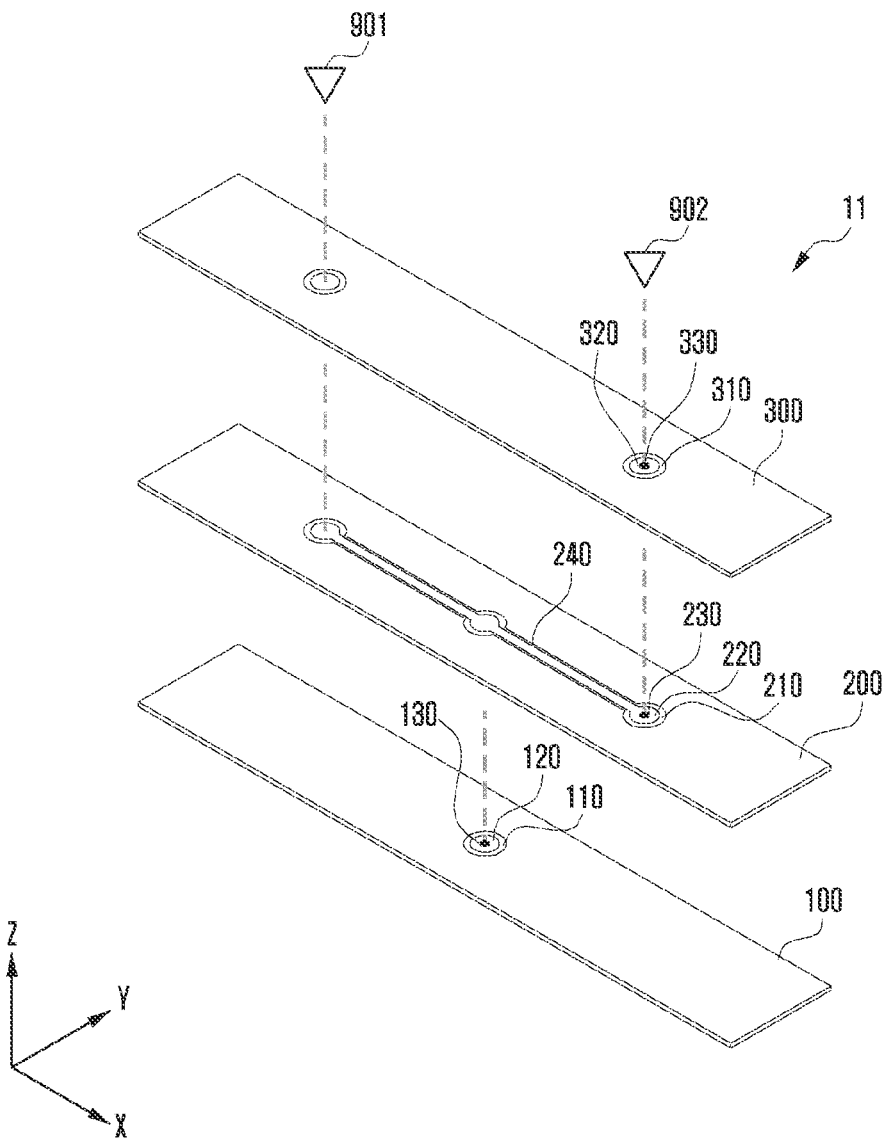

FIG. 3

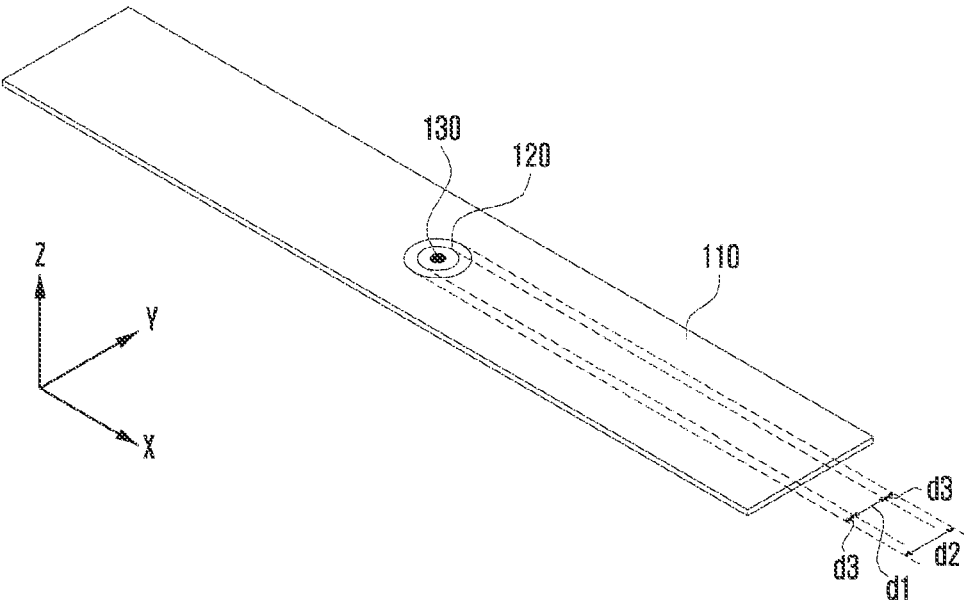

FIG. 4

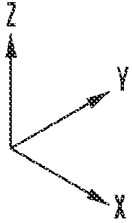
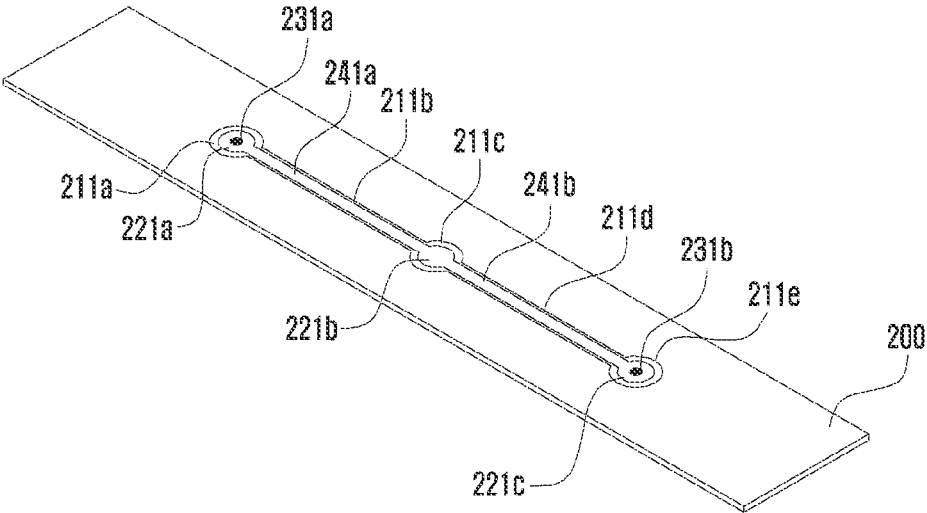

FIG. 5

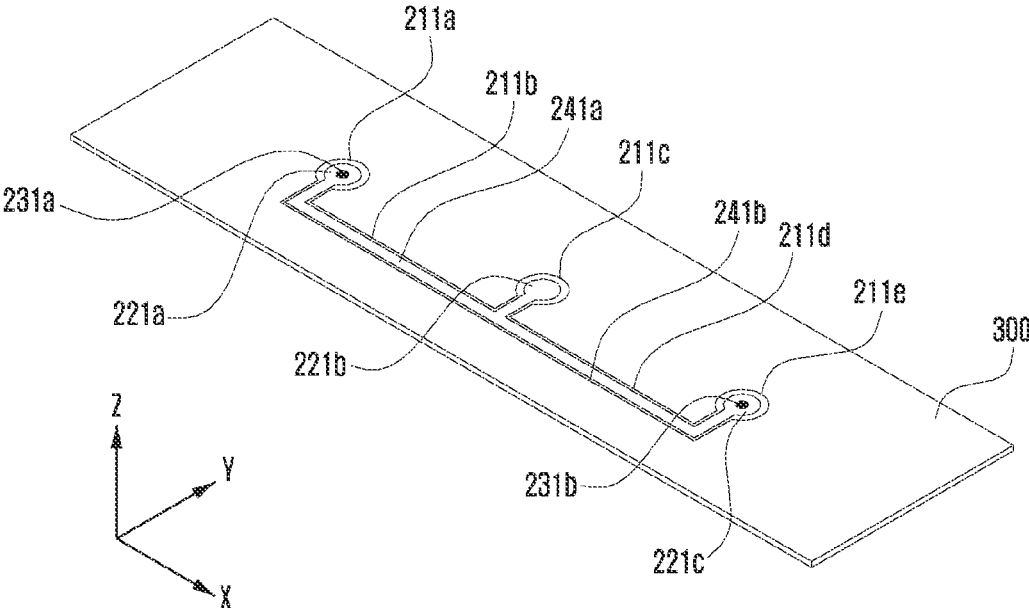

FIG. 6

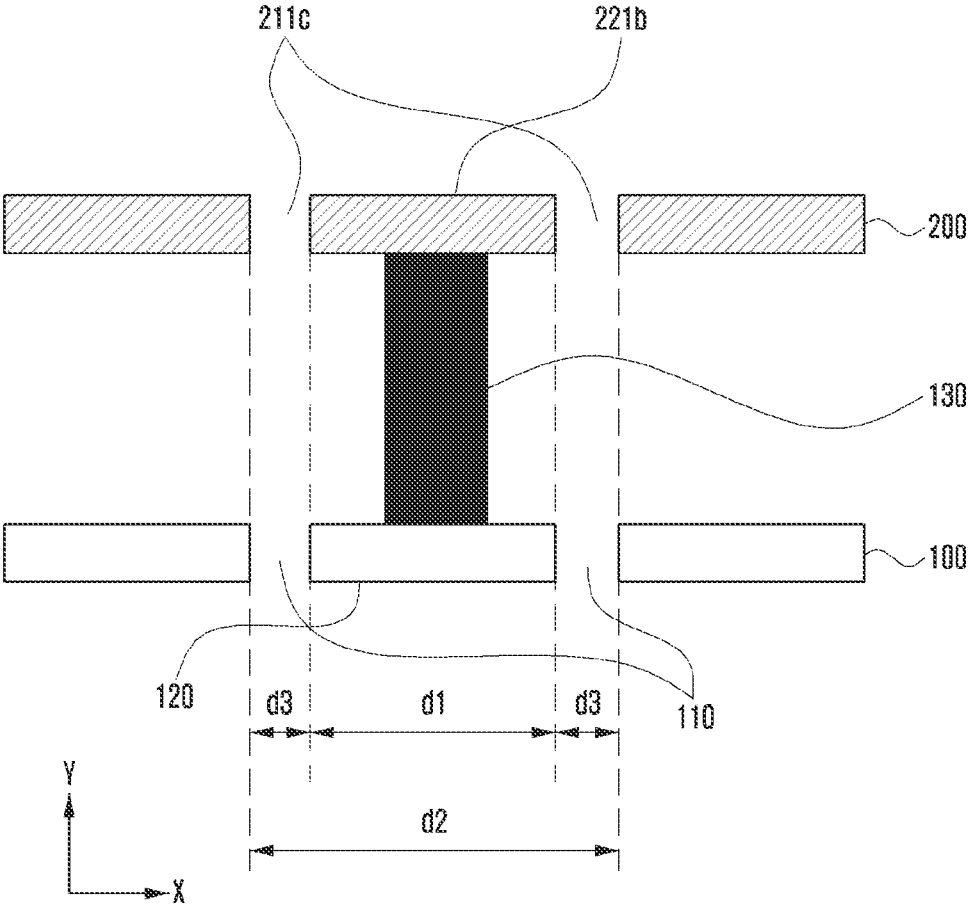

FIG. 7

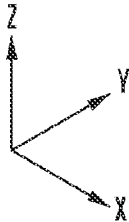
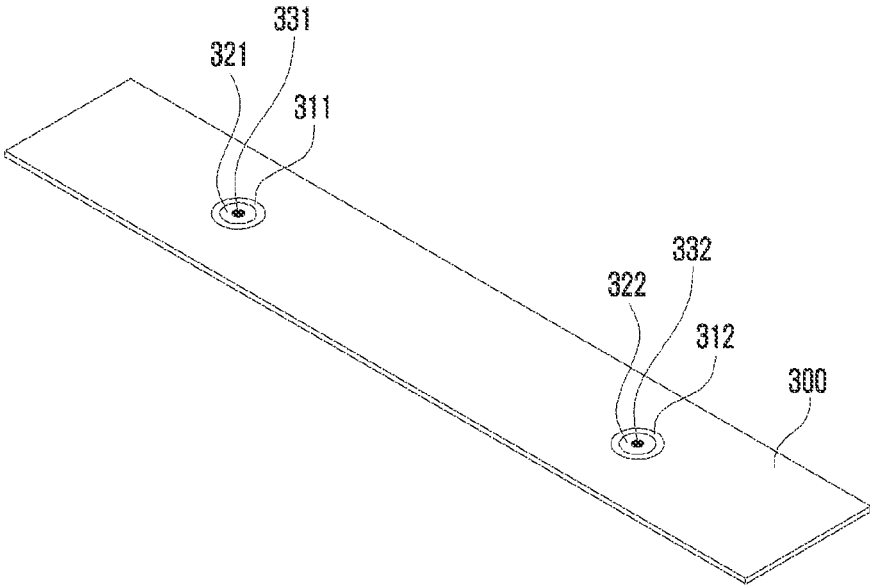



FIG. 8

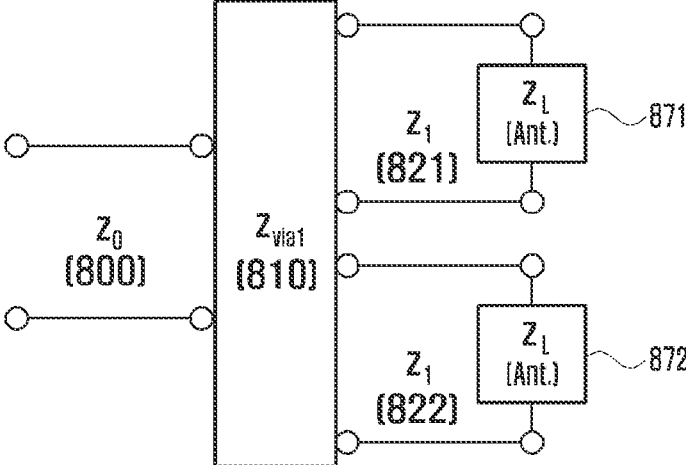

FIG. 9

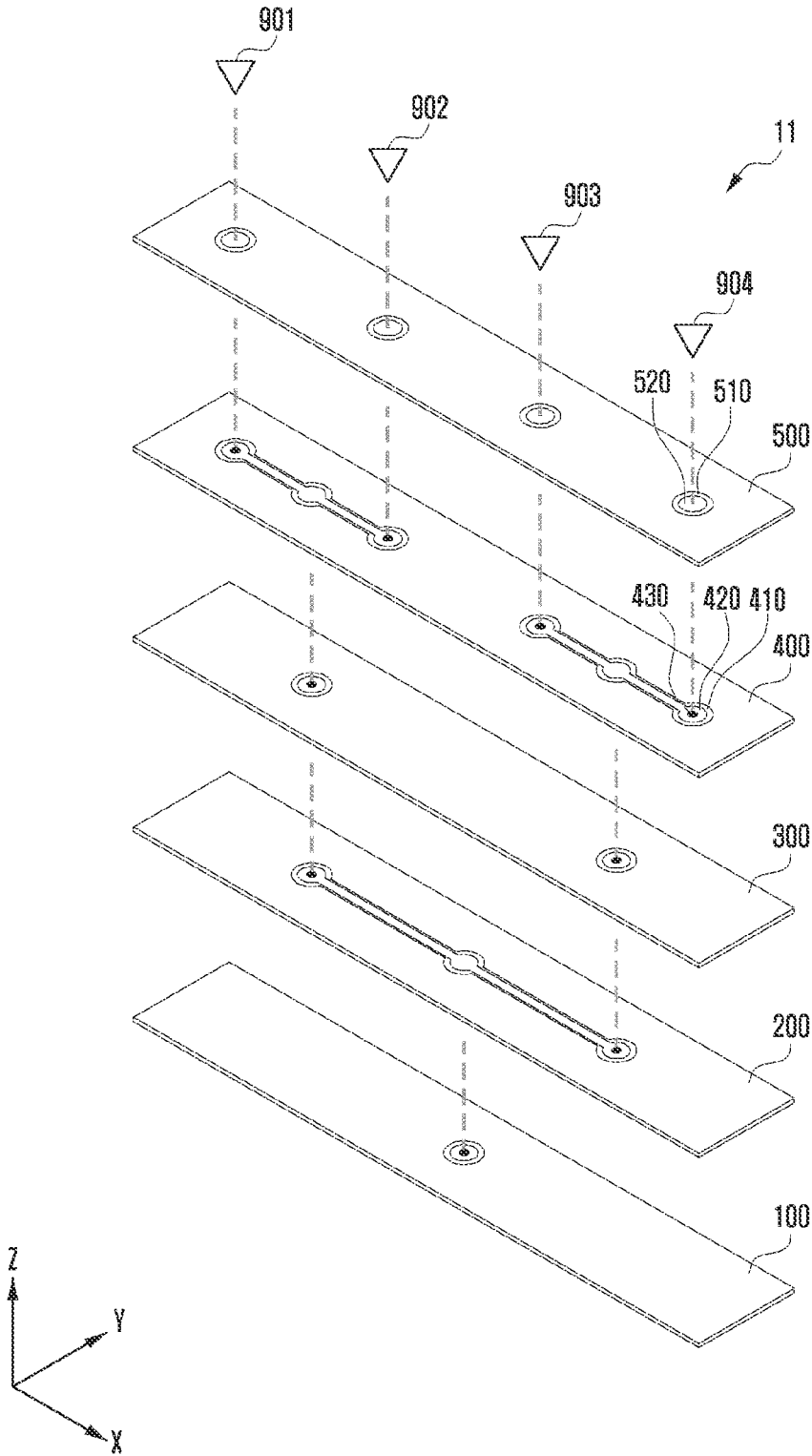

FIG. 10

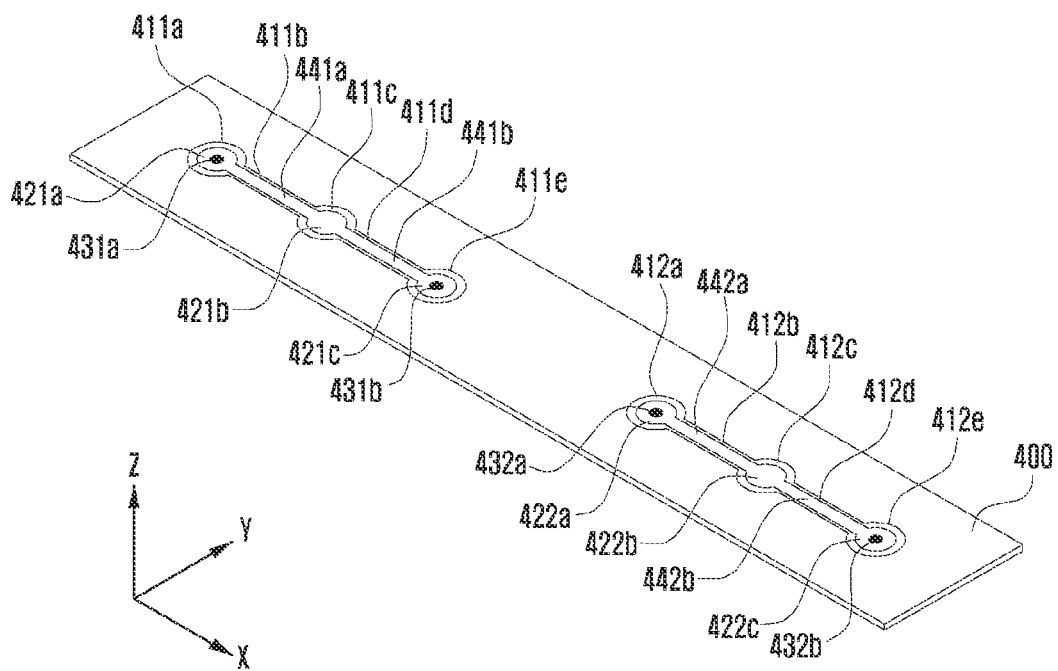

FIG. 11

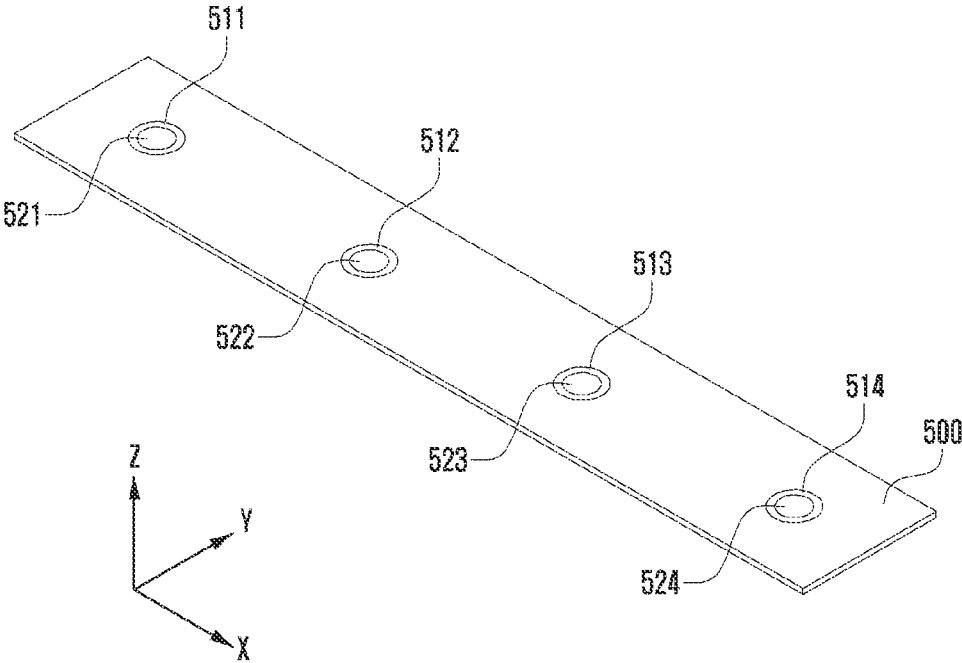

FIG. 12

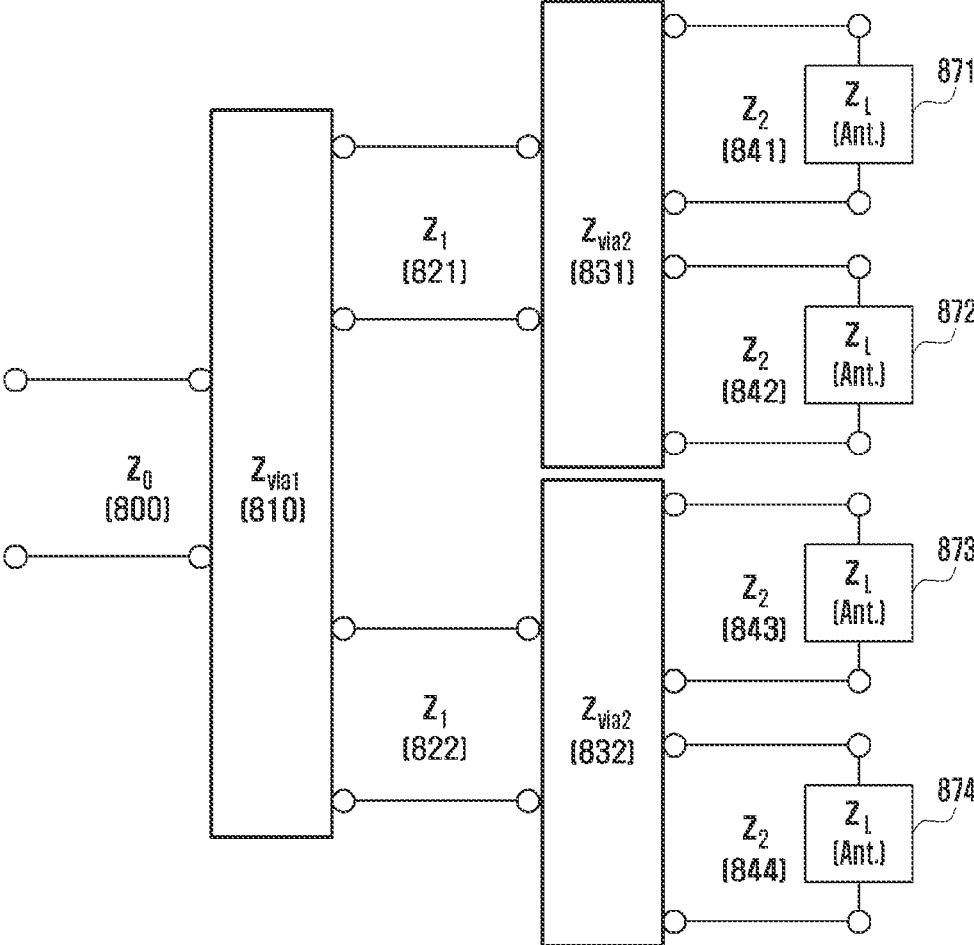

FIG. 13

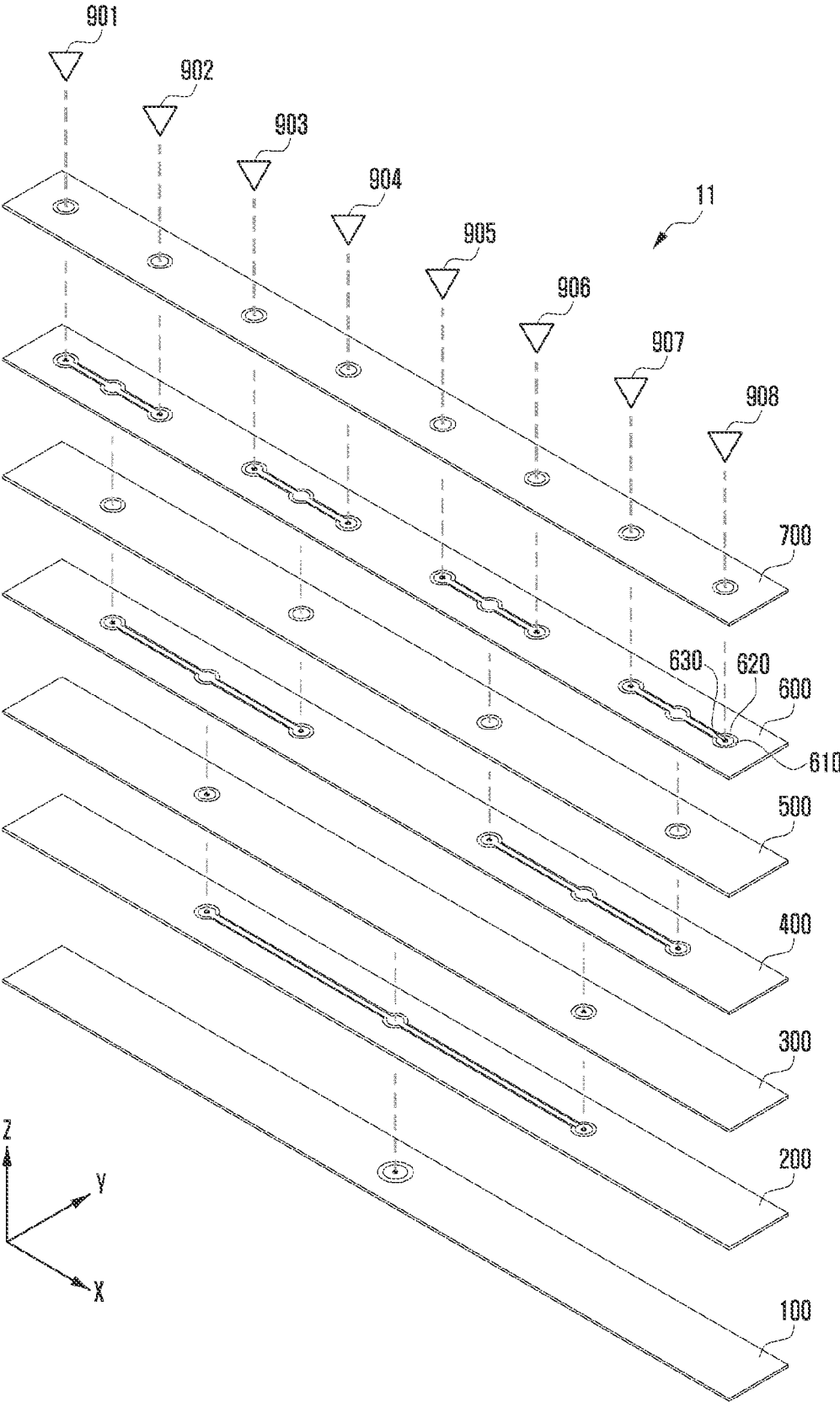

FIG. 14

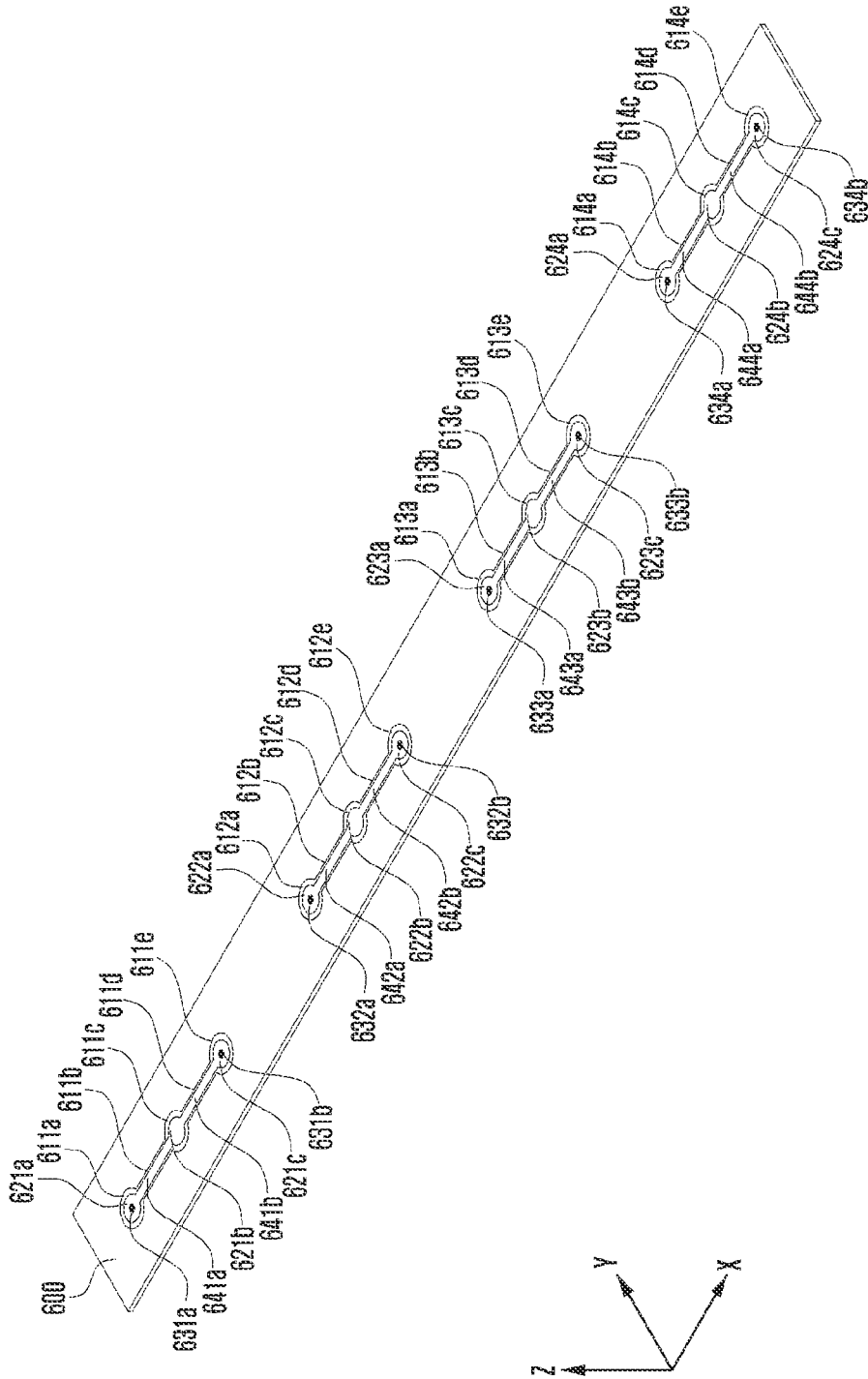

FIG. 15

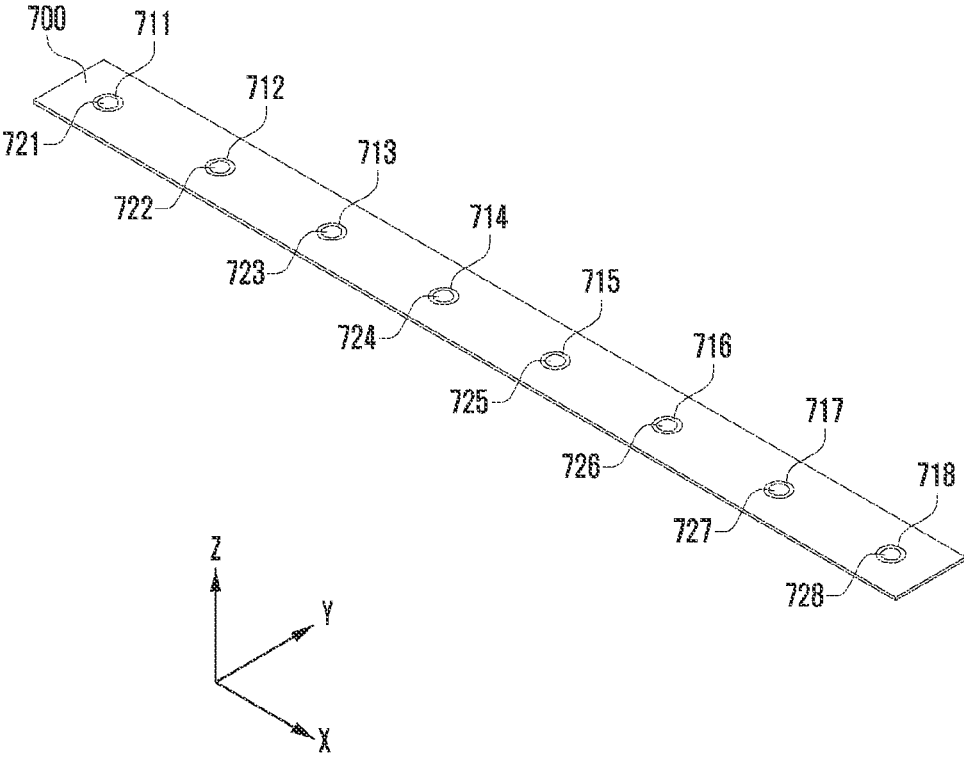



FIG. 16

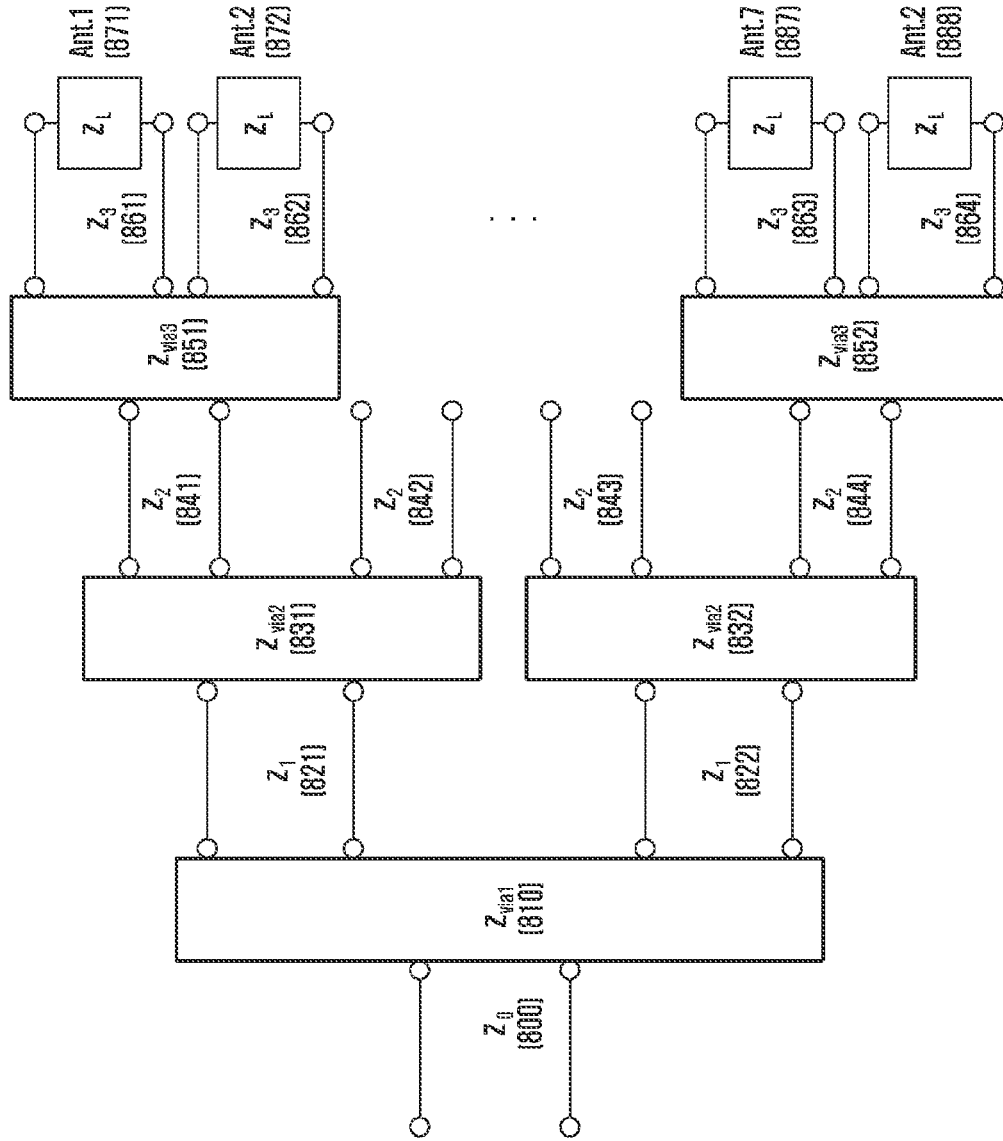

FIG. 17

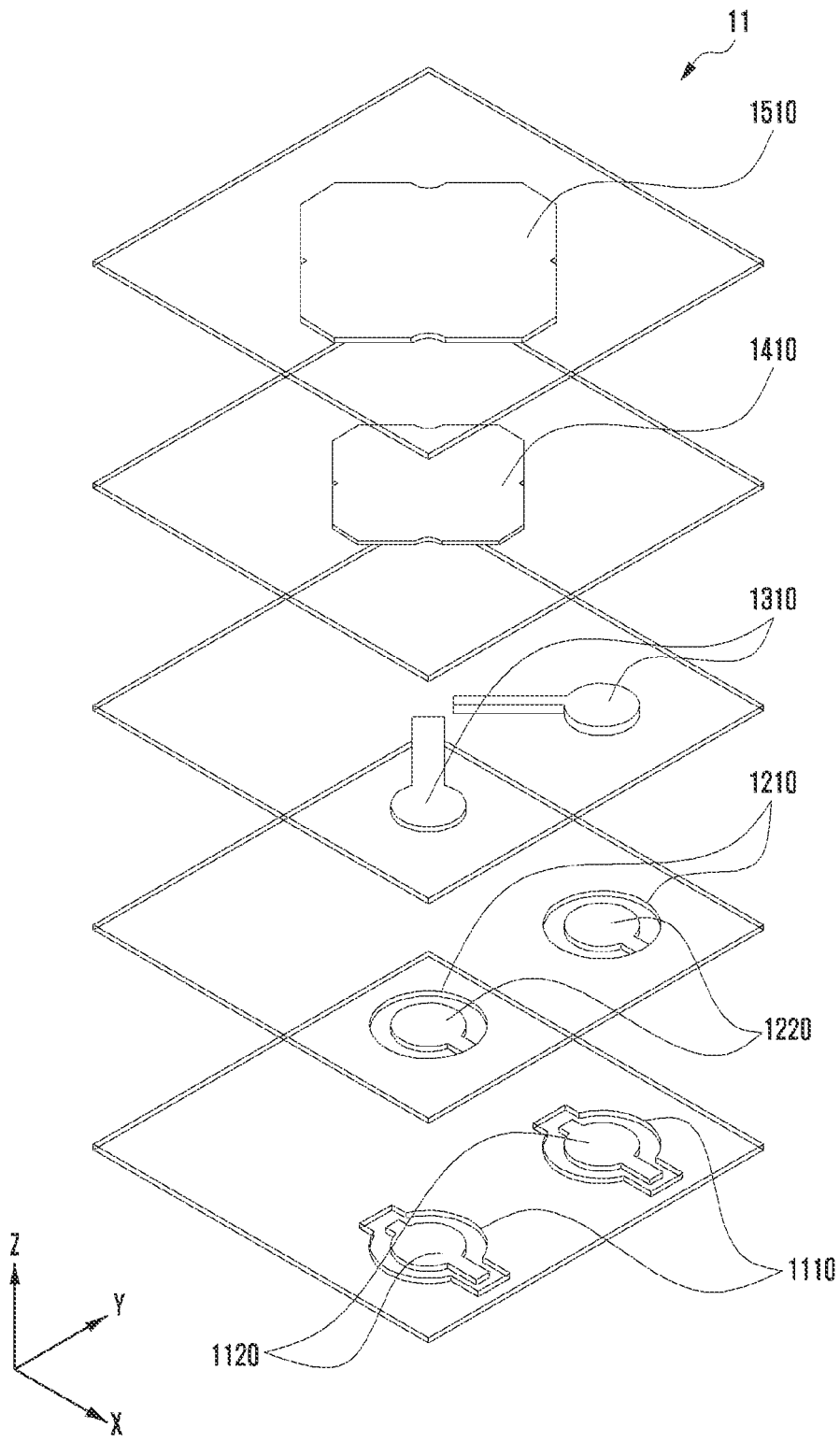
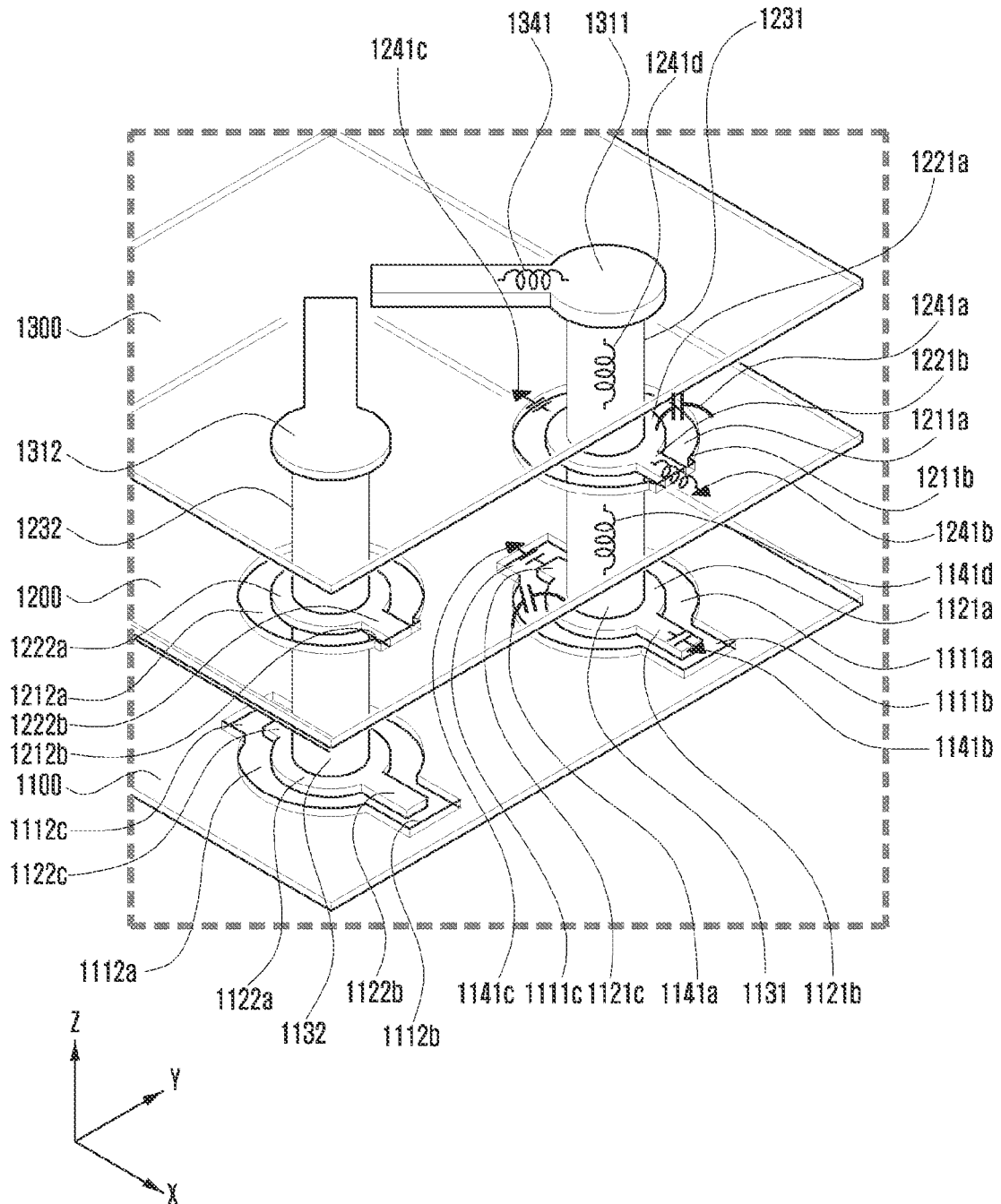

FIG. 18



## ANTENNA MODULE AND ELECTRONIC DEVICE COMPRISING SAME

### PRIORITY

**[0001]** This application is a National Phase Entry of PCT International Application No PCT/KR2022/006082, which was filed on Apr. 28, 2022, and claims priority to Korean Patent Application No. 10-2021-0066644, which was filed on May 25, 2021, the entire content of each of which is incorporated herein by reference.

### TECHNICAL FIELD

**[0002]** Various embodiments of the disclosure relate to an antenna module, and more particularly, to an antenna module and an electronic device including the same.

### BACKGROUND ART

**[0003]** 5G mobile communication technology defines a wide frequency band to enable a fast transmission speed and new services, and may be implemented not only in a frequency ('sub 6 GHz') band of 6 GHz or less such as 3.5 GHz, but also in an ultra high frequency band ('above 6 GHz') called a mmWave such as 28 GHz and 39 GHz. Further, in the case of 6G mobile communication technology, which is referred to as a beyond 5G system, in order to achieve a transmission speed that is 50 times faster than that of 5G mobile communication technology and ultra-low latency reduced to  $\frac{1}{10}$  compared to that of 5G mobile communication technology, implementations in terahertz bands (e.g., such as 95 GHz to 3 terahertz (3 THz) band) are being considered.

**[0004]** In the early days of 5G mobile communication technology, with the goal of satisfying the service support and performance requirements for an enhanced mobile broadband (eMBB), ultra-reliable low-latency communications (URLLC), and massive machine-type communications (mMTC), standardization has been carried out for beamforming and massive MIMO for mitigating a path loss of radio waves in an ultra-high frequency band and increasing a propagation distance of radio waves, and support for various numerologies (multiple subcarrier spacing operation, and the like) for efficient use of ultra-high frequency resources and dynamic operation for slot formats, initial access technology for supporting multi-beam transmission and broadband, a definition and operation of a band-width part (BWP), a new channel coding method such as low density parity check (LDPC) code for large capacity data transmission and polar code for high reliable transmission of control information, L2 pre-processing, and network slicing that provides a dedicated network specialized for specific services.

**[0005]** Currently, discussions are ongoing to improve initial 5G mobile communication technology and enhance a performance thereof in consideration of services that 5G mobile communication technology was intended to support, and physical layer standardization for technologies such as vehicle-to-everything (V2X) for helping driving determination of an autonomous vehicle and increasing user convenience based on a location and status information of the vehicle transmitted by the vehicle, new radio unlicensed (NR-U) for the purpose of a system operation that meets various regulatory requirements in unlicensed bands, NR UE power saving, a non-terrestrial network (NTN), which is

direct UE-satellite communication for securing coverage in areas where communication with a terrestrial network is impossible, and positioning is in progress.

**[0006]** Further, standardization in the field of air interface architecture/protocol for technologies such as industrial Internet of things (IIoT) for supporting new services through linkage and convergence with other industries, integrated access and backhaul (IAB) that provides nodes for expanding network service areas by integrating wireless backhaul links and access links, mobility enhancement including conditional handover and dual active protocol stack (DAPS) handover, and 2-step RACH for NR that simplifies a random access procedure is also in progress, and standardization in the field of system architecture/service for 5G baseline architecture (e.g., service based architecture, service based interface) for applying network functions virtualization (NFV) and software-defined networking (SDN) technologies, mobile edge computing (MEC) that receives services based on a location of a UE, and the like is also in progress.

**[0007]** When such a 5G mobile communication system is commercialized, connected devices in an explosive increase trend will be connected to communication networks; thus, it is expected that function and performance enhancement of a 5G mobile communication system and integrated operation of connected devices will be required. To this end, new research on eXtended reality (XR) for efficiently supporting augmented reality (AR), virtual reality (VR), mixed reality (MR), and the like, 5G performance improvement and complexity reduction using artificial intelligence (AI) and machine learning (ML), AI service support, metaverse service support, and drone communication will be conducted.

**[0008]** Further, the development of such a 5G mobile communication system will be the basis for the development of full duplex technology for improving frequency efficiency and system network of 6G mobile communication technology, satellite, AI-based communication technology that utilizes artificial intelligence (AI) from a design stage and that realizes system optimization by internalizing end-to-end AI support functions, and next generation distributed computing technology that realizes complex services beyond the limits of UE computing capabilities by utilizing ultra-high-performance communication and computing resources as well as a new waveform for ensuring coverage in a terahertz band of 6G mobile communication technology, full dimensional MIMO (FD-MIMO), multi-antenna transmission technologies such as an array antenna and large scale antenna, metamaterial-based lenses and antennas for improving coverage of terahertz band signals, high-dimensional spatial multiplexing technology using orbital angular momentum (OAM), and reconfigurable intelligent surface (RIS) technology.

### DISCLOSURE

#### Technical Problem

**[0009]** Various embodiments provide an antenna array module that implements vertically a feeding network in order to solve space limitations.

**[0010]** Various embodiments provide an antenna module for maximizing isolation between branched wirings in a THz band by inserting a ground (GND) layer in a vertical branch structure.

**[0011]** Various embodiments provide a power divider implemented vertically that may be operated without a

separate impedance matching circuit using impedance by a parasitic component generated in via transition of a vertical structure.

#### Technical Solution

**[0012]** According to various embodiments, an antenna module includes a first layer including a first etching area, a first via pad disposed to be spaced apart from an edge of the first etching area, and a first via hole disposed at one surface of the first via pad; a second layer stacked on one surface of the first layer and including a second etching area, a plurality of second via pads disposed to be spaced apart from an edge of the second etching area, a plurality of second via holes disposed at one surface of the plurality of second via pads, and a plurality of second dividing lines configured to electrically connect the plurality of second via pads; a third layer stacked on one surface of the second layer and including a plurality of third etching areas, a plurality of third via pads disposed to be spaced apart from an edge of the plurality of third etching areas, and a plurality of third via holes disposed at one surface of the plurality of third via pads; a fourth layer stacked on one surface of the third layer and including a plurality of fourth etching areas, a plurality of fourth pads disposed to be spaced apart from edges of the plurality of fourth etching areas, a plurality of fourth via holes disposed at one surface of the plurality of fourth via pads, and a plurality of fourth dividing lines; a fifth layer stacked on one surface of the fourth layer and including a plurality of fifth etching areas and a plurality of fifth via pads disposed to be spaced apart from edges of the plurality of fifth etching areas; and a plurality of antennas electrically connected to the plurality of fifth via pads.

#### Advantageous Effects

**[0013]** An antenna module according to various embodiments can solve space limitations by implementing vertically a feeding network.

**[0014]** An antenna module according to various embodiments can maximize isolation between branched wirings in a THz band by inserting a ground (GND) layer in a vertical branch structure.

**[0015]** An antenna module according to various embodiments can operate without a separate impedance matching circuit using impedance by a parasitic component generated in via transition of a vertical structure.

#### DESCRIPTION OF DRAWINGS

**[0016]** FIG. 1 is a block diagram illustrating an electronic device 10 in a network environment according to various embodiments.

**[0017]** FIG. 2 is a conceptual diagram illustrating an antenna module 11 according to various embodiments.

**[0018]** FIG. 3 is a conceptual diagram illustrating a first layer 100 of an antenna module 11 according to various embodiments.

**[0019]** FIG. 4 is a conceptual diagram illustrating a second layer 200 of an antenna module 11 according to various embodiments.

**[0020]** FIG. 5 is a conceptual diagram illustrating a y-axis cross-section of a layer including an etching area, a via pad, and a via hole of an antenna module 11 according to various embodiments.

**[0021]** FIG. 6 is a conceptual diagram illustrating a third layer 300 of an antenna module 11 according to various embodiments.

**[0022]** FIG. 7 is a conceptual diagram illustrating a third layer 300 of an antenna module 11 according to various embodiments.

**[0023]** FIG. 8 is a conceptual diagram illustrating impedance of an antenna module 11 according to various embodiments.

**[0024]** FIG. 9 is a conceptual diagram illustrating an antenna module 11 according to various embodiments.

**[0025]** FIG. 10 is a conceptual diagram illustrating a fourth layer 400 of an antenna module 11 according to various embodiments.

**[0026]** FIG. 11 is a conceptual diagram illustrating a fifth layer 500 of an antenna module 11 according to various embodiments.

**[0027]** FIG. 12 is a conceptual diagram illustrating impedance of an antenna module 11 according to various embodiments.

**[0028]** FIG. 13 is a conceptual diagram illustrating an antenna module 11 according to various embodiments.

**[0029]** FIG. 14 is a conceptual diagram illustrating a sixth layer 600 of an antenna module 11 according to various embodiments.

**[0030]** FIG. 15 is a conceptual diagram illustrating a seventh layer 700 of an antenna module 11 according to various embodiments.

#### MODE FOR DISCLOSURE

**[0031]** Hereinafter, an operating principle of the disclosure will be described in detail with reference to the accompanying drawings. In the following description, in describing the disclosure, in the case that it is determined that a detailed description of a related well-known function or constitution may unnecessarily obscure the gist of the disclosure, a detailed description thereof will be omitted. Terms described below are terms defined in consideration of functions in the disclosure, which may vary according to intentions or customs of users and operators. Therefore, the definition should be made based on the content throughout this specification.

**[0032]** Hereinafter, a term identifying a communication or an access node used in the description, a term indicating network entities, a term indicating messages, a term indicating an interface between network objects, a term indicating various identification information and the like are exemplified for convenience of description. Accordingly, the disclosure is not limited to the terms described below, and other terms indicating an object having an equivalent technical meaning may be used.

**[0033]** Hereinafter, for convenience of description, the disclosure uses terms and names defined in 5GS and NR standards, which are the latest standards defined by the 3rd generation partnership project (3GPP) organization among currently existing communication standards. However, the disclosure is not limited by the terms and names, and may be equally applied to a wireless communication network conforming to other standards. In particular, the disclosure is applicable to 3GPP 5GS/NR (5th generation mobile communication standard).

**[0034]** FIG. 1 is a block diagram illustrating an electronic device 10 in a network environment according to various embodiments.

**[0035]** With reference to FIG. 1, in a network environment, the electronic device 10 may communicate with another electronic device (not illustrated) or a server (not illustrated) through a network (e.g., wired or wireless communication network). For example, the electronic device 10 may be a base station. Another electronic device may be a terminal.

**[0036]** According to an embodiment, the electronic device 10 may include an antenna module 11, a communication module 12, a processor 13, a memory 14, and an interface 15. In some embodiments, at least one of these components may be omitted in the electronic device 10 or one or more other components may be added to the electronic device 10. In some embodiments, some of these components may be integrated into a single component.

**[0037]** The processor 13 may, for example, control at least one other component (e.g., hardware or software component) of the electronic device 10 connected thereto and perform various data processing or calculations. According to an embodiment, as at least part of data processing or calculation, the processor 13 may store commands or data received from other components (e.g., the communication module 12) in the memory 14, process the commands or data stored in the memory 14, and store the resulting data in the memory 14.

**[0038]** The memory 14 may store various data used by at least one component of the electronic device 10. The data may include, for example, software and input data or output data for commands related thereto.

**[0039]** The interface 15 may support one or more specified protocols that may be used for enabling the electronic device 10 to connect directly or wirelessly with another electronic device. According to an embodiment, the interface 15 may include, for example, a universal serial bus (USB) interface or a secure digital (SD) card interface.

**[0040]** The communication module 12 may support establishing a wired communication channel or a wireless communication channel between the electronic device 10 and another electronic device or server, and performing communication through the established communication channel. The communication module 12 may include one or more communication processors that operate independently of the processor 13 and that support wired or wireless communication. According to an embodiment, the communications module 12 may communicate with other electronic devices or servers through a legacy cellular network, a 5G network, a next generation communication network, the Internet, or a computer network (e.g., telecommunication network such as local area network (LAN) or wide area network (WAN)). These various types of communication modules may be integrated into one component (e.g., single chip) or implemented into a plurality of separate components (e.g., a plurality of chips).

**[0041]** The communication module 12 may support a 5G network after the 4G network and a next generation communication technology, for example, new radio access technology (NR access technology). NR access technologies may support enhanced mobile broadband (eMBB) of high-capacity data, terminal power minimization and massive machine type communications (mMTC), or ultra-reliable and low-latency communications (URLLC). The communication module 12 may support, for example, a high frequency band (e.g., mmWave band) in order to achieve a high data rate. The communication module 12 may support

various technologies for securing a performance in a high frequency band, for example, technologies such as beam-forming, massive multiple-input and multiple-output (MIMO), full dimensional MIMO (FD-MIMO), array antenna, analog beam-forming, or large scale antenna. The communication module 12 may support various requirements specified for the electronic device 10, other electronic devices, or network systems.

**[0042]** The antenna module 11 may transmit or receive signals or power to or from the outside (e.g., other electronic devices). According to an embodiment, the antenna module 11 may include an antenna including a radiator formed with a conductor or a conductive pattern formed on a substrate (e.g., PCB). According to an embodiment, the antenna module 11 may include a plurality of antennas (e.g., array antenna). In this case, at least one antenna appropriate for a communication method used in the network may be selected from the plurality of antennas by, for example, the communication module 12. A signal or power may be transmitted or received between the communication module 12 and another external electronic device through the selected at least one antenna. According to some embodiments, in addition to the radiator, other components (e.g., radio frequency integrated circuit (RFIC)) may be additionally formed as a part of the antenna module 11.

**[0043]** According to various embodiments, the antenna module 11 may form a mmWave antenna module. According to an embodiment, the mmWave antenna module may include a printed circuit board, an RFIC disposed on or adjacent to a first surface (e.g., lower surface) of the printed circuit board and capable of supporting a designated high frequency band (e.g., mmWave band), and a plurality of antennas (e.g., array antennas) disposed on or adjacent to a second surface (e.g., upper surface or side surface) of the printed circuit board and capable of transmitting or receiving signals of the designated high frequency band.

**[0044]** At least some of the components may be connected to each other through a communication method between peripheral devices (e.g., bus, general purpose input and output (GPIO), serial peripheral interface (SPI), or mobile industry processor interface (MIPI)) and exchange signals (e.g., commands or data) with each other.

**[0045]** According to an embodiment, commands or data may be transmitted or received between the electronic device 10 and another external electronic device through a server connected to a network. Other external electronic devices may be devices of the same type as or different type from that of the electronic device 10. According to an embodiment, all or part of operations executed in the electronic device 10 may be executed in another external electronic device. For example, in the case that the electronic device 10 needs to perform a certain function or service automatically or in response to a request from a user or other device, the electronic device 10 may request to one or more external electronic devices to perform a function or at least part of the service additionally or instead of executing the function or service by itself. One or more other external electronic devices that have received the request may execute at least a part of the requested function or service or an additional function or service related to the request, and transfer the result of the execution to the electronic device 10. The electronic device 10 may provide the result as it is or the result obtained after additional processing as at least part of a response to the request. To this end, for example,

cloud computing, distributed computing, mobile edge computing (MEC), or client-server computing technology may be used. The electronic device **10** may provide an ultra-low latency service using, for example, distributed computing or mobile edge computing. In another embodiment, other external electronic devices may include internet of things (IoT) devices.

**[0046]** An electronic device according to various embodiments disclosed in this document may be various types of devices. The electronic device according to the embodiment of this document is not limited to the above-described devices.

**[0047]** It should be understood that various embodiments of this document and terms used therein are not intended to limit the technical features described in this document to specific embodiments, but include various modifications, equivalents, or substitutions of the embodiments. In connection with the description of the drawings, like reference numerals may be used for similar or related components. The singular form of the noun corresponding to the item may include one or more of the item, unless the relevant context clearly dictates otherwise. In this document, each of phrases such as “A or B”, “at least one of A and B”, “at least one of A or B”, “A, B, or C”, “at least one of A, B and C”, and “at least one of A, B, or C” may include any one of, or all possible combinations of, items listed together in the corresponding one of the phrases. Terms such as “first” or “second” may be simply used for distinguishing a corresponding component from other corresponding components, and do not limit the corresponding components in other aspects (e.g., importance or order). In the case that one (e.g., first) component is referred to as “coupled” or “connected” to another (e.g., second) component, with or without the terms “functionally” or “communicatively, it means that the one component may be connected to the other component directly (e.g., by wire), wirelessly, or through a third component.

**[0048]** The term “module” used in various embodiments of this document may include a unit implemented in hardware, software, or firmware, and may be used interchangeably with terms such as, for example, logic, logic block, part, or circuit. A module may be an integrally formed part or a minimum unit or a portion of the part that performs one or more functions. For example, according to an embodiment, the module may be implemented in the form of an application-specific integrated circuit (ASIC).

**[0049]** Various embodiments of this document may be implemented into software including one or more instructions stored in a storage medium (e.g., the memory **14**) readable by a machine (e.g., the electronic device **10**). For example, the processor (e.g., the processor **13**) of the device (e.g., the electronic device **10**) may call and execute at least one command among one or more stored instructions from a storage medium. This makes it possible for the device to be operated to perform at least one function according to the called at least one instruction. The one or more instructions may include a code generated by a compiler or a code executable by an interpreter. The device readable storage medium may be provided in the form of a non-transitory storage medium. Here, ‘non-transitory’ only means that the storage medium is a tangible device and does not include a signal (e.g., electromagnetic wave), and this term does not

distinguish the case that data is semi-permanently stored in the storage medium and the case that data is temporary stored.

**[0050]** According to an embodiment, a method according to various embodiments disclosed in this document may be provided as included in a computer program product. Computer program products may be traded between sellers and buyers as commodities. The computer program product may be distributed in the form of a machine readable storage medium (e.g., compact disc read only memory (CD-ROM)), or via an application store (e.g., Play Store™) or may be distributed (e.g., download or upload) online directly between two user devices (e.g., smartphones). In the case of online distribution, at least a part of the computer program product may be at least temporarily stored or temporarily generated in a machine readable storage medium such as a memory of a server of a manufacturer, a server of an application store, or a relay server.

**[0051]** According to various embodiments, each component (e.g., module or program) of the above-described components may include a singular or a plurality of entities, and some of the plurality of entities may be separately disposed in other components. According to various embodiments, one or more components or operations among the above-described corresponding components may be omitted, or one or more other components or operations may be added. Alternatively or additionally, a plurality of components (e.g., module or program) may be integrated into one component. In this case, the integrated component may perform one or more functions of each component of the plurality of components identically or similarly to those performed by the corresponding component among the plurality of components prior to the integration. According to various embodiments, operations performed by a module, program, or other component may be executed sequentially, in parallel, repeatedly, or heuristically, or one or more of the operations may be executed in a different order, or omitted, or one or more other operations may be added.

**[0052]** FIG. 2 is a conceptual diagram illustrating an antenna module **11** according to various embodiments.

**[0053]** With reference to FIG. 2, the antenna module **11** may include a plurality of layers **100** to **300**.

**[0054]** A first layer **100** may be referred to as a first isolation ground (GND) layer. For example, the first layer **100** may include a first etching area **110**, a first via pad **120**, and a first via hole **130**.

**[0055]** A second layer **200** may be referred to as a first dividing line layer. The second layer **200** may be stacked on one surface of the first layer **100**. The second layer **200** may include a second etching area **210**, a second via pad **220**, a second via hole **230**, and a second dividing line **240**.

**[0056]** A third layer **300** may be referred to as a second isolation ground layer. For example, the third layer **300** may include a third etching area **310**, a third via pad **320**, and a third via hole **330**.

**[0057]** For example, the first layer **100** may be the same as that illustrated in FIG. 3. The second layer **200** may be the same as that illustrated in FIG. 4. The third layer **300** may be the same as that illustrated in FIG. 5.

**[0058]** FIG. 3 is a conceptual diagram illustrating a first layer **100** of an antenna module **11** according to various embodiments.

**[0059]** With reference to FIG. 3, the first etching area **110** may be an etched portion of the first layer **100**. For example,

the first etching area **110** may be an area penetrating the first layer **100** in the z-axis direction.

[0060] The first via pad **120** may be disposed in the first etching area **110**. A length of a width  $d1$  of the first via pad **120** may be smaller than that of a width  $d2$  of the first etching area **110**. For example, the first via pad **120** may be spaced apart from an edge of the first etching area **110** by a predetermined distance  $d3$ .

[0061] The first via hole **130** may be disposed at one surface of the first via pad **120**. A length of a width of the first via hole **130** may be smaller than that of the first via pad **120**.

[0062] FIG. 4 is a conceptual diagram illustrating a second layer **200** of an antenna module **11** according to various embodiments.

[0063] With reference to FIG. 4, the second etching area **210** may be an etched portion of the second layer **200**. For example, the second etching area **210** may be an area penetrating the second layer **200** in the z-axis direction. For example, the second etching area **210** may include a 2a-th etching area **211a**, a 2b-th etching area **211b**, a 2c-th etching area **211c**, a 2d-th etching area **211d**, and a 2e-th etching area **211e**.

[0064] The 2a-th etching area **211a**, the 2c-th etching area **211c**, and the 2e-th etching area **211e** may be formed to be spaced apart from each other by a predetermined distance in the x-axis direction.

[0065] The 2b-th etching area **211b** may be formed between the 2a-th etching area **211a** and the 2c-th etching area **211c**.

[0066] The 2d-th etching area **211d** may be formed between the 2c-th etching area **211c** and the 2e-th etching area **211e**.

[0067] The second via pad **220** may be disposed in the second etching area **210**. For example, the second via pad **220** may be spaced apart from an edge of the second etching area **210** by a predetermined distance.

[0068] For example, the second via pad **220** may include a 2a-th via pad **221a**, a 2b-th via pad **221b**, and a 2c-th via pad **221c**. A length of a width of each of the second via pads **220** may be the same or similar.

[0069] The 2a-th via pad **221a** may be disposed in the 2a-th etching area **211a**. A length of a width of the 2a-th via pad **221a** may be smaller than that of the 2a-th etching area **211a**. For example, the 2a-th via pad **221a** may be spaced apart from an edge of the 2a-th etching area **211a** by a predetermined distance  $d3$ .

[0070] The 2b-th via pad **221b** may be disposed in the 2c-th etching area **211c**. A length of a width of the 2b-th via pad **221b** may be smaller than that of the 2c-th etching area **211c**. For example, the 2b-th via pad **221b** may be spaced apart from an edge of the 2c-th etching area **211c** by a predetermined distance  $d3$ . The 2b-th via pad **221b** may be electrically connected to the first via hole **130**. For example, one end of the first via hole **130** may be electrically connected to the other surface of the 2b-th via pad **221b**.

[0071] The 2c-th via pad **221c** may be disposed in the 2e-th etching area **211e**. A length of a width of the 2c-th via pad **221c** may be smaller than that of the 2e-th etching area **211e**. For example, the 2c-th via pad **221c** may be spaced apart from an edge of the 2e-th etching area **211e** by a predetermined distance  $d3$ .

[0072] A length of a width of each of the second via holes **230** may be smaller than that of each of the via pads **220**. The second via hole **230** may include a 2a-th via hole **231a** and a 2b-th via hole **231b**.

[0073] The 2a-th via hole **231a** may be disposed at one surface of the 2a-th via pad **221a**. A length of a width of the 2a-th via hole **231a** may be smaller than that of the 2a-th via pad **221a**.

[0074] The 2b-th via hole **231b** may be disposed at one surface of the 2c-th via pad **221c**. A length of a width of the 2b-th via hole **231b** may be smaller than that of the 2c-th via pad **221c**.

[0075] The second dividing line **240** may include a 2a-th dividing line **241a** and a 2b-th dividing line **241b**.

[0076] The 2a-th dividing line **241a** may be disposed between the 2a-th via pad **221a** and the 2b-th via pad **221b**. For example, one end of the 2a-th dividing line **241a** may be electrically connected to the 2a-th via pad **221a**. The other end of the 2a-th dividing line **241a** may be electrically connected to the 2b-th via pad **221b**.

[0077] The 2a-th dividing line **241a** may be disposed in the 2b-th etching area **211b**. A length of a width of the 2a-th dividing line **241a** may be smaller than that of the 2b-th etching area **211b**. For example, the 2a-th dividing line **241a** may be spaced apart from the 2b-th etching area **211b** by a predetermined distance.

[0078] The 2b-th dividing line **241b** may be disposed between the 2b-th via pad **221b** and the 2c-th via pad **221c**. For example, one end of the 2b-th dividing line **241b** may be electrically connected to the 2b-th via pad **221b**. The other end of the 2b-th dividing line **241b** may be electrically connected to the 2c-th via pad **221c**.

[0079] The 2b-th dividing line **241b** may be disposed in the 2d-th etching area **211d**. A length of a width of the 2b-th dividing line **241b** may be smaller than that of the 2d-th etching area **211d**. For example, the 2b-th dividing line **241b** may be spaced apart from the 2d-th etching area **211d** by a predetermined distance.

[0080] FIG. 5 is a conceptual diagram illustrating a third layer **300** of an antenna module **11** according to various embodiments.

[0081] With reference to FIG. 5, the 2b-th etching area **211b** and the 2d-th etching area **211d** of the third layer **300** may have various shapes. For example, the 2b-th etching area **211b** and the 2d-th etching area **211d** may have an alphabet E shape. For example, the 2b-th etching area **211b** may have a partial shape of the alphabet E and connect the 2a-th etching area **211a** and the 2c-th etching area **211c**. The 2d-th etching area **211d** may have a partial shape of the alphabet E and connect the 2c-th etching area **211c** and the 2e-th etching area **211e**.

[0082] The second dividing line **240** of the third layer **300** may have various shapes. For example, the second dividing line **240** may have an alphabet E shape.

[0083] The 2a-th dividing line **241a** may have a partial shape of the alphabet E and electrically connect the 2a-th via pad **221a** and the 2b-th via pad **221b**. For example, one end of the 2a-th dividing line **241a** may be electrically connected to the 2a-th via pad **221a**. The other end of the 2a-th dividing line **241a** may be electrically connected to the 2b-th via pad **221b**.

[0084] The 2a-th dividing line **241a** may have a partial shape of the alphabet E and be disposed in the 2b-th etching area **211b**. A length of a width of the 2a-th dividing line **241a**



may be smaller than that of the 2b-th etching area **211b**. For example, the 2a-th dividing line **241a** may be spaced apart from the 2b-th etching area **1211b** by a predetermined distance.

[0085] The 2b-th dividing line **241b** may have a partial shape of the alphabet E and electrically connect the 2b-th via pad **221b** and the 2c-th via pad **221c**. For example, one end of the 2b-th dividing line **241b** may be electrically connected to the 2b-th via pad **221b**. The other end of the 2b-th dividing line **241a** may be electrically connected to the 2c-th via pad **221c**.

[0086] The 2b-th dividing line **241b** may have a partial shape of the alphabet E and be disposed in the 2d-th etching area **211d**. A length of a width of the 2b-th dividing line **241b** may be smaller than that of the 2d-th etching area **211d**. For example, the 2b-th dividing line **241b** may be spaced apart from the 2d-th etching area **211d** by a predetermined distance.

[0087] FIG. 6 is a conceptual diagram illustrating a y-axis cross-section of a layer including an etching area, a via pad, and a via hole of an antenna module **11** according to various embodiments.

[0088] With reference to FIG. 6, the first via pad **120** may be disposed in the first etching area **110**. A length of a width **d1** of the first via pad **120** may be smaller than that of a width **d2** of the first etching area **110**. For example, the first via pad **120** may be spaced apart from an edge of the first etching area **110** by a predetermined distance **d3**.

[0089] The first via hole **130** may be disposed at one surface of the first via pad **120**. A length of a width of the first via hole **130** may be smaller than that of the first via pad **120**.

[0090] The 2b-th via pad **221b** may be disposed in the 2c-th etching area **211c**. A length of a width of the 2b-th via pad **221b** may be smaller than that of the 2c-th etching area **211c**. For example, the 2b-th via pad **221b** may be spaced apart from an edge of the 2c-th etching area **211c** by a predetermined distance **d3**. The 2b-th via pad **221b** may be electrically connected to the first via hole **130**. For example, one end of the first via hole **130** may be electrically connected to the other surface of the 2b-th via pad **221b**.

[0091] FIG. 6 illustrates a y-axis cross section of a first via hole **130** among a plurality of via holes of the antenna module **11** for convenience of description, but the disclosure is not limited thereto, and a structure of FIG. 6 may be the same as or similar to that of at least one of the plurality of via holes of the antenna module **11** according to various embodiments to be described later.

[0092] FIG. 6 illustrates y-axis cross-sections of the first via pad **120** and the 2b-th via pad **221b** connected to the first via hole **130** among a plurality of via pads of the antenna module **11** for convenience of description, but the disclosure is not limited thereto, and the structure of FIG. 6 may be the same as or similar to that of at least one of the plurality of via pads of the antenna module **11** according to various embodiments to be described later.

[0093] FIG. 7 is a conceptual diagram illustrating a third layer **300** of an antenna module **11** according to various embodiments.

[0094] With reference to FIG. 7, the third etching area **310** may include a 3-1st etching area **311** and a 3-2nd etching area **312**. The 3-1st etching area **311** and the 3-2nd etching area **312** may be spaced apart from each other by a predetermined distance in the x-axis direction on the third layer.

[0095] The 3-1st etching area **311** may be an etched portion of the third layer **300**. For example, the 3-1st etching area **311** may be an area penetrating the third layer **300** in the z-axis direction.

[0096] The 3-2nd etching area **312** may be an etched portion of the third layer **300**. For example, the 3-2nd etching area **312** may be an area penetrating the third layer **300** in the z-axis direction.

[0097] The third via pad **320** may include a 3-1st via pad **321** and a 3-2nd via pad **322**. The 3-1st via pad **321** may be disposed in the 3-1st etching area **311**. A length of a width of the 3-1st via pad **321** may be smaller than that of the 3-1st etching area **311**. For example, the 3-1st via pad **321** may be spaced apart from an edge of the 3-1st etching area **311** by a predetermined distance. The 3-1st via pad **321** may be electrically connected to the 2a-th via hole **230a**. For example, one end of the 2a-th via hole **230a** may be electrically connected to the other surface of the 3-1st via pad **321**.

[0098] The 3-2nd via pad **322** may be disposed in the 3-2nd etching area **312**. A length of a width of the 3-2nd via pad **322** may be smaller than that of the 3-2nd etching area **312**. For example, the 3-2nd via pad **322** may be spaced apart from an edge of the 3-2nd etching area **312** by a predetermined distance. The 3-2nd via pad **322** may be electrically connected to the 2b-th via hole **230b**. For example, one end of the 2b-th via hole **230b** may be electrically connected to the other surface of the 3-2nd via pad **322**.

[0099] The plurality of third via holes **330** may include a 3-1st via hole **331** and a 3-2nd via hole **332**.

[0100] The 3-1st via hole **331** may be disposed at one surface of the 3-1st via pad **321**. A length of a width of the 3-1st via hole **331** may be smaller than that of the 3-1st via pad **321**.

[0101] The 3-2nd via hole **332** may be disposed at one surface of the 3-2nd via pad **322**. A length of a width of the 3-2nd via hole **332** may be smaller than that of the 3-2nd via pad **322**.

[0102] A plurality of antennas **901** and **902** may be electrically connected to the third via pad **320**. For example, a first antenna **901** may be electrically connected to one surface of the 3-1st via pad **321**. A second antenna **902** may be electrically connected to one surface of the 3-2nd via pad **322**.

[0103] The first via pad **120** may receive a signal input from the communication module **12**. A signal input through the first via pad **120** may be transmitted to the second via pad **220** through the first via hole **130**.

[0104] For example, a signal input through the first via pad **120** may be transmitted to the 2b-th via pad **221b** through the first via hole **130**. A signal transmitted to the 2b-th via pad **221b** may be distributed to the 2a-th dividing line **241a** and the 2b-th dividing line **241b**. For example, a signal transmitted to the 2b-th via pad **221b** may be transmitted to the 2a-th via pad **221a** through the 2a-th dividing line **241a**. A signal transmitted to the 2b-th via pad **221b** may be transmitted to the 2c-th via pad **221c** through the 2b-th dividing line **241b**.

[0105] A signal transmitted to the 2a-th via pad **221a** may be transmitted to the 3-1st via pad **321** through the 2a-th via hole **231a**. A signal transmitted to the 2b-th via pad **221b** may be transmitted to the 3-2nd via pad **322** through the 2c-th via hole **231c**.

[0106] A signal transmitted to the 3-1st via pad 321 may be transmitted to the first antenna 901. A signal transmitted to the 3-2nd via pad 322 may be transmitted to the second antenna 902.

[0107] The first antenna 901 may radiate a signal received from the 3-1st via pad 321. The second antenna 902 may radiate a signal received from the 3-2nd via pad 322.

[0108] The impedance of the antenna module 11 according to the flow of the signal may be the same as that of FIG. 8.

[0109] FIG. 8 is a conceptual diagram illustrating impedance of an antenna module 11 according to various embodiments.

[0110] With reference to FIG. 8, in the antenna module 11, zero impedance Z0, 800, first via impedance Zvia1, 810, first dividing impedance Z1, 821 and 822, antenna impedance ZL(Ant), 871 and 872 may be generated. The first dividing impedance Z1, 821 and 822 may include 1-1st dividing impedance Z1, 821 and 1-2nd dividing impedance Z1, 822. The antenna impedance ZL(Ant), 871 and 872 may include first antenna impedance ZL(Ant), 871 and second antenna impedance ZL(Ant), 872.

[0111] For example, the zero impedance Z0, 800 may be generated in a conductive line in which a signal flows between the first via pad 120 and the communication module 12.

[0112] The first via impedance Zvia1, 810 may be generated in the first via hole 130. The first via hole 130 may have first via impedance Zvia1, 810.

[0113] The 1-1st dividing impedance Z1, 821 may be generated in the 2a-th dividing line 241a. The 2a-th dividing line 241a may have 1-1st dividing impedance Z1, 821.

[0114] The 1-2nd dividing impedance Z1, 822 may be generated in the 2b-th dividing line 241b. The 2b-th dividing line 241b may have 1-2nd dividing impedance Z1, 822.

[0115] The first antenna impedance ZL(Ant.1) 871 may be generated in a conductive line in which a signal flows from the 2a-th via hole 231a to the first antenna 901.

[0116] The second antenna impedance ZL(Ant.2) 872 may be generated in a conductive line in which a signal flows from the 2c-th via hole 231c to the second antenna 902.

[0117] The first via impedance Zvia1, 810 may be determined based on at least one of the 1-1st dividing impedance Z1, 821, the 1-2nd dividing impedance Z1, 822, the first antenna impedance ZL(Ant.1) 871, the second antenna impedance ZL(Ant.2) 872, a distance of a conductive line in which the first antenna impedance ZL(Ant.1) 871 is generated, and a distance of a conductive line in which the second antenna impedance ZL(Ant. 2) 872 is generated.

[0118] The first via impedance Zvia1, 810 may be determined based on a separation distance d3 between edges of the first via pad 120 and the first etching area 110.

[0119] The first via impedance Zvia1, 810 may be determined based on a separation distance d3 between edges of the 2c-th via pad 221c and the 2e-th etching area 211e.

[0120] The first via impedance Zvia1, 810 may be determined based on at least one of a separation distance d3 between edges of the first via pad 120 and the first etching area 110, and a separation distance d3 between edges of the 2c-th via pad 221c and the 2e-th etching area 211e.

[0121] The separation distance d3 between edges of the first via pad 120 and the first etching area 110 and the separation distance d3 between edges of the 2c-th via pad 221c and the 2e-th etching area 211e may be the same or different.

[0122] FIG. 9 is a conceptual diagram illustrating an antenna module 11 according to various embodiments.

[0123] With reference to FIG. 9, the antenna module 11 may further include a fourth layer 400 and a fifth layer 500. For example, the fourth layer 400 may be stacked on one surface of the third layer 300 in the y-axis direction.

[0124] The fourth layer 400 may be referred to as a second dividing line layer. The fourth layer 400 may include a fourth etching area 410, a fourth via pad 420, a fourth via hole 430, and a fourth dividing line 440.

[0125] The fifth layer 500 may be referred to as an antenna ground layer. The fifth layer 500 may include a fifth etching area 510 and a fifth via pad 520.

[0126] For example, the fourth layer 400 may be the same as that illustrated in FIG. 10. The fifth layer 500 may be the same as that illustrated in FIG. 11.

[0127] FIG. 10 is a conceptual diagram illustrating a fourth layer 400 of an antenna module 11 according to various embodiments.

[0128] With reference to FIG. 10, a fourth etching area 410 may be etched portions of the fourth layer 400. For example, the fourth etching area 410 may be areas penetrating the fourth layer 400 in the z-axis direction.

[0129] The fourth etching area 410 may include a 4-1st etching area 411 and a 4-2nd etching area 412. The 4-1st etching area 411 and the 4-2nd etching area 412 may be formed to be spaced apart from each other by a predetermined distance in the x-axis direction on the fourth layer 400.

[0130] The 4-1st etching area 411 may include a 4-1a-th etching area 411a, a 4-1b-th etching area 411b, a 4-1c-th etching area 411c, a 4-1d-th etching area 411d, and a 4-1e-th etching area 411e.

[0131] The 4-1a-th etching area 411a, the 4-1c-th etching area 411c, and the 4-1e-th etching area 411e may be formed to be spaced apart from each other by a predetermined distance in the x-axis direction on the fourth layer.

[0132] The 4-1b-th etching area 411b may be formed between the 4-1a-th etching area 411a and the 4-1c-th etching area 411c.

[0133] The 4-1d-th etching area 411d may be formed between the 4-1c-th etching area 411c and the 4-1e-th etching area 411e.

[0134] The 4-2th etching area 412 may include a 4-2a-th etching area 412a, a 4-2b-th etching area 412b, a 4-2c-th etching area 412c, a 4-2d-th etching area 412d, and a 4-2e-th etching area 412e.

[0135] The 4-2a-th etching area 412a, the 4-2c-th etching area 412c, and the 4-2e-th etching area 412e may be formed to be spaced apart from each other by a predetermined distance in the x-axis direction on the fourth layer.

[0136] The 4-2b-th etching area 412b may be formed between the 4-2a-th etching area 412a and the 4-2c-th etching area 412c.

[0137] The 4-2d-th etching area 412d may be formed between the 4-2c-th etching area 412c and the 4-2e-th etching area 412e.

[0138] The fourth via pad 420 may include a 4-1st via pad 1421 and a 4-2nd via pad 1422.

[0139] The 4-1st via pad 421 may be disposed in the 4-1st etching area 411. For example, the 4-1st via pad 421 may be spaced apart from an edge of the 4-1st etching area 411 by a predetermined distance.

[0140] The 4-2nd via pad **422** may be disposed in the 4-2nd etching area **412**. For example, the 4-2nd via pad **422** may be spaced apart from an edge of the 4-2nd etching area **412** by a predetermined distance *d*.

[0141] The 4-1th via pad **421** may include a 4-1a-th via pad **421a**, a 4-1b-th via pad **421b**, and a 4-1c-th via pad **421c**. A length of a width of each of the 4-1st via pads **421** may be the same or similar.

[0142] For example, the 4-1a-th via pad **421a** may be disposed in the 4-1a-th etching area **411a**. A length of a width of the 4-1a-th via pad **421a** may be smaller than that of the 4-1a-th etching area **411a**. For example, the 4-1a-th via pad **421a** may be spaced apart from an edge of the 4-1a-th etching area **411a** by a predetermined distance.

[0143] The 4-1b-th via pad **421b** may be disposed in the 4-1c-th etching area **411c**. A length of a width of the 4-1b-th via pad **421b** may be smaller than that of the 4-1c-th etching area **411c**. For example, the 4-1b-th via pad **421b** may be spaced apart from an edge of the 4-1c-th etching area **411c** by a predetermined distance. The 4-1b-th via pad **421b** may be electrically connected to the 3-1st via hole **331**. For example, one end of the 3-1st via hole **331** may be electrically connected to the other surface of the 4-1b-th via pad **421b**.

[0144] The 4-1e-th via pad **421c** may be disposed in the 4-1e-th etching area **411e**. A length of a width of the 4-1c-th via pad **421c** may be smaller than that of the 4-1e-th etching area **411e**. For example, the 4-1c-th via pad **421c** may be spaced apart from an edge of the 4-1e-th etching area **411e** by a predetermined distance.

[0145] The 4-2nd via pad **422** may include a 4-2a-th via pad **422a**, a 4-2b-th via pad **422b**, and a 4-2c-th via pad **422c**. A length of a width of each of the plurality of 4-2nd via pads **422** may be the same or similar.

[0146] For example, the 4-2a-th via pad **422a** may be disposed in the 4-2a-th etching area **412a**. A length of a width of the 4-2a-th via pad **422a** may be smaller than that of the 4-2a-th etching area **412a**. For example, the 4-2a-th via pad **422a** may be spaced apart from an edge of the 4-2a-th etching area **412a** by a predetermined distance.

[0147] The 4-2b-th via pad **422b** may be disposed in the 4-2c-th etching area **412c**. A length of a width of the 4-2b-th via pad **422b** may be smaller than that of the 4-2c-th etching area **412c**. For example, the 4-2b-th via pad **422b** may be spaced apart from an edge of the 4-2c-th etching area **412c** by a predetermined distance. The 4-2b-th via pad **422b** may be electrically connected to the 3-2nd via hole **332**. For example, one end of the 3-2nd via hole **332** may be electrically connected to the other surface of the 4-2b-th via pad **422b**.

[0148] The 4-2c-th via pad **422c** may be disposed in the 4-2e-th etching area **412e**. A length of a width of the 4-2c-th via pad **422c** may be smaller than that of the 4-2e-th etching area **412e**. For example, the 4-2c-th via pad **422c** may be spaced apart from an edge of the 4-2e-th etching area **412e** by a predetermined distance.

[0149] A length of a width of each of the fourth via holes **430** may be smaller than that of each of the fourth via pads **420**. The fourth via hole **430** may include a 4-1a-th via hole **431a**, a 4-1b via hole **431b**, a 4-2a-th via hole **432a**, and a 4-2b-th via hole **432b**.

[0150] The 4-1a-th via hole **431a** may be disposed at one surface of the 4-1a-th via pad **421a**. A length of a width of the 4-1a-th via hole **431a** may be smaller than that of the 4-1a-th via pad **421a**.

[0151] The 4-1b via hole **431b** may be disposed at one surface of the 4-1c-th via pad **421c**. A length of a width of the 4-1b via hole **431b** may be smaller than that of the 4-1c-th via pad **421c**.

[0152] The 4-2a-th via hole **432a** may be disposed at one surface of the 4-2a-th via pad **422a**. A length of a width of the 4-2a-th via hole **432a** may be smaller than that of the 4-2a-th via pad **422a**.

[0153] The 4-2b-th via hole **432b** may be disposed at one surface of the 4-2c-th via pad **422c**. A length of a width of the 4-2b-th via hole **432b** may be smaller than that of the 4-2c-th via pad **422c**.

[0154] The fourth dividing line **440** may include a 4-1a-th dividing line **441a**, a 4-1b-th dividing line **441b**, a 4-2a-th dividing line **442a**, and a 4-2b-th dividing line **442b**.

[0155] The 4-1a-th dividing line **441a** may be disposed between the 4-1a-th via pad **421a** and the 4-1b-th via pad **421b**. For example, one end of the 4-1a-th dividing line **441a** may be electrically connected to the 4-1a-th via pad **421a**. The other end of the 4-1a-th dividing line **441a** may be electrically connected to the 4-1b-th via pad **421b**.

[0156] The 4-1a-th dividing line **441a** may be disposed in the 4-1b-th etching area **411b**. A length of a width of the 4-1a-th dividing line **441a** may be smaller than that of the 4-1b-th etching area **411b**. For example, the 4-1a-th dividing line **441a** may be spaced apart from the 4-1b-th etching area **411b** by a predetermined distance.

[0157] The 4-1b-th dividing line **441b** may be disposed between the 4-1b-th via pad **421b** and the 4-1c-th via pad **421c**. For example, one end of the 4-1b-th dividing line **441b** may be electrically connected to the 4-1b-th via pad **421b**. The other end of the 4-1b-th dividing line **441b** may be electrically connected to the 4-1c-th via pad **421c**.

[0158] The 4-1b-th dividing line **441b** may be disposed in the 4-1d-th etching area **411d**. A length of a width of the 4-1b-th dividing line **441b** may be smaller than that of the 4-1d-th etching area **411d**. For example, the 4-1b-th dividing line **441b** may be spaced apart from the 4-1d-th etching area **411d** by a predetermined distance.

[0159] The 4-2a-th dividing line **442a** may be disposed between the 4-2a-th via pad **422a** and the 4-2b-th via pad **422b**. For example, one end of the 4-2a-th dividing line **442a** may be electrically connected to the 4-2a-th via pad **422a**. The other end of the 4-2a-th dividing line **442a** may be electrically connected to the 4-2b-th via pad **422b**.

[0160] The 4-2a-th dividing line **442a** may be disposed in the 4-2b-th etching area **412b**. A length of a width of the 4-2a-th dividing line **442a** may be smaller than that of the 4-2b-th etching area **412b**. For example, the 4-2a-th dividing line **442a** may be spaced apart from the 4-2b-th etching area **412b** by a predetermined distance.

[0161] The 4-2b-th dividing line **442b** may be disposed between the 4-2b-th via pad **422b** and the 4-2c-th via pad **422c**. For example, one end of the 4-2b-th dividing line **442b** may be electrically connected to the 4-2b-th via pad **422b**. The other end of the 4-2b-th dividing line **442b** may be electrically connected to the 4-2c-th via pad **422c**.

[0162] The 4-2b-th dividing line **442b** may be disposed in the 4-2d-th etching area **412d**. A length of a width of the 4-2b-th dividing line **442b** may be smaller than that of the

4-2d-th etching area **412d**. For example, the 4-2b-th dividing line **442b** may be spaced apart from the 4-2d-th etching area **412d** by a predetermined distance.

[0163] FIG. 11 is a conceptual diagram illustrating a fifth layer **500** of an antenna module **11** according to various embodiments.

[0164] With reference to FIG. 11, a fifth etching area **510** may include a 5-1st etching area **511**, a 5-2nd etching area **512**, a 5-3rd etching area **513**, and a 5-4th etching area **514**.

[0165] The 5-1st etching area **511**, the 5-2nd etching area **512**, the 5-3rd etching area **513**, and the 5-4th etching area **514** may be formed to be spaced apart from each other by a predetermined distance in the x-axis direction on the fifth layer **500**.

[0166] The 5-1st etching area **511** may be an etched portion of the fifth layer **500**. For example, the 5-1st etching area **511** may be an area penetrating the fifth layer **500** in the z-axis direction.

[0167] The 5-2nd etching area **512** may be an etched portion of the fifth layer **500**. For example, the 5-2nd etching area **512** may be an area penetrating the fifth layer **500** in the z-axis direction.

[0168] The 5-3rd etching area **513** may be an etched portion of the fifth layer **500**. For example, the 5-3rd etching area **513** may be an area penetrating the fifth layer **500** in the z-axis direction.

[0169] The 5-4th etching area **514** may be an etched portion of the fifth layer **500**. For example, the 5-4th etching area **514** may be an area penetrating the fifth layer **500** in the z-axis direction.

[0170] The plurality of fifth via pads **520** may include a 5-1st via pad **521**, a 5-2nd via pad **522**, a 5-3rd via pad **523**, and a 5-4th via pad **524**.

[0171] The 5-1st via pad **521** may be disposed in the 5-1st etching area **511**. A length of a width of the 5-1st via pad **521** may be smaller than that of the 5-1st etching area **511**. For example, the 5-1st via pad **521** may be spaced apart from an edge of the 5-1st etching area **511** by a predetermined distance. The 5-1st via pad **521** may be electrically connected to the 4-1a-th via hole **431a**. For example, one end of the 4-1a-th via hole **431a** may be electrically connected to the other surface of the 5-1st via pad **521**.

[0172] The 5-2nd via pad **522** may be disposed in the 5-2nd etching area **512**. A length of a width of the 5-2nd via pad **522** may be smaller than that of the 5-2nd etching area **512**. For example, the 5-2nd via pad **522** may be spaced apart from an edge of the 5-2nd etching area **512** by a predetermined distance. The 5-2nd via pad **522** may be electrically connected to the 4-1b via hole **431b**. For example, one end of the 4-1b via hole **431b** may be electrically connected to the other surface of the 5-2nd via pad **522**.

[0173] The 5-3rd via pad **523** may be disposed in the 5-3rd etching area **513**. A length of a width of the 5-3rd via pad **523** may be smaller than that of the 5-3rd etching area **513**. For example, the 5-3rd via pad **523** may be spaced apart from an edge of the 5-3rd etching area **513** by a predetermined distance. The 5-3rd via pad **523** may be electrically connected to the 4-2a-th via hole **432a**. For example, one end of the 4-2a-th via hole **432a** may be electrically connected to the other surface of the 5-3rd via pad **523**.

[0174] The 5-4th via pad **524** may be disposed in the 5-4th etching area **514**. A length of a width of the 5-4th via pad **524** may be smaller than that of the 5-4th etching area **514**. For

example, the 5-4th via pad **524** may be spaced apart from an edge of the 5-4th etching area **514** by a predetermined distance. The 5-4th via pad **524** may be electrically connected to the 4-2b-th via hole **432b**. For example, one end of the 4-2b-th via hole **432b** may be electrically connected to the other surface of the 5-4th via pad **524**.

[0175] The plurality of antennas **901** to **904** may be electrically connected to the plurality of fifth via pads **520**. For example, the first antenna **901** may be electrically connected to one surface of the 5-1st via pad **521**. The second antenna **902** may be electrically connected to one surface of the 5-2nd via pad **522**. The third antenna **903** may be electrically connected to one surface of the 5-3rd via pad **523**. The fourth antenna **904** may be electrically connected to one surface of the 5-4th via pad **524**.

[0176] A signal transmitted to the 3-1st via pad **321** may be transmitted to the 4-1st via pad **421** through the 3-1st via hole **331**. For example, a signal transmitted to the 3-1st via pad **321** may be transmitted to the 4-1c-th via pad **421c** through the 3-1st via hole **331**.

[0177] A signal transmitted to the 4-1c-th via pad **421c** may be distributed to the 4-1a-th dividing line **441a** and the 4-1b-th dividing line **441b**. For example, a signal transmitted to the 4-1c-th via pad **421c** may be transmitted to the 4-1a-th via pad **421a** through the 4-1a-th dividing line **441a**. A signal transmitted to the 4-1c-th via pad **421c** may be transmitted to the 4-1b-th via pad **421b** through the 4-1b-th dividing line **441b**.

[0178] A signal transmitted to the 4-1a-th via pad **421a** may be transmitted to the 5-1a-th via pad **521** through the 4-1a-th via hole **431a**. A signal transmitted to the 4-1b-th via pad **421b** may be transmitted to the 5-2nd via pad **522** through the 4-1c-th via hole **431c**.

[0179] A signal transmitted to the 5-1st via pad **521** may be transmitted to the first antenna **901**. A signal transmitted to the 5-2nd via pad **522** may be transmitted to the second antenna **902**.

[0180] The first antenna **901** may radiate a signal received from the 5-1st via pad **521**. The second antenna **902** may radiate a signal received from the 5-2nd via pad **522**.

[0181] A signal transmitted to the 3-2nd via pad **322** may be transmitted to the 4-2nd via pad **422** through the 3-2nd via hole **332**. For example, a signal transmitted to the 3-2nd via pad **322** may be transmitted to the 4-2c-th via pad **422c** through the 3-2nd via hole **332**.

[0182] A signal transmitted to the 4-2c-th via pad **422c** may be distributed to the 4-2a-th dividing line **442a** and the 4-2b-th dividing line **442b**. For example, a signal transmitted to the 4-2c-th via pad **422c** may be transmitted to the 4-2a-th via pad **422a** through the 4-2a-th dividing line **442a**. A signal transmitted to the 4-2c-th via pad **422c** may be transmitted to the 4-2b-th via pad **422b** through the 4-2b-th dividing line **442b**.

[0183] A signal transmitted to the 4-2a-th via pad **422a** may be transmitted to the 5-2nd via pad **522** through the 4-2a-th via hole **432a**. A signal transmitted to the 4-2b-th via pad **422b** may be transmitted to the 5-3rd via pad **523** through the 4-2c-th via hole **432c**.

[0184] A signal transmitted to the 5-3rd via pad **523** may be transmitted to the third antenna **903**. A signal transmitted to the 5-4th via pad **524** may be transmitted to the fourth antenna **904**.

[0185] The third antenna **903** may radiate a signal received from the 5-3rd via pad **523**. The fourth antenna **904** may radiate a signal received from the 5-4th via pad **524**.

[0186] The impedance of the antenna module **11** according to the signal flow may be the same as that illustrated in FIG. **12**.

[0187] FIG. **12** is a conceptual diagram illustrating impedance of an antenna module **11** according to various embodiments.

[0188] With reference to FIG. **12**, in the antenna module **11**, zero impedance  $Z_0$ , **800**, first via impedance  $Z_{via1}$ , **810**, first dividing impedance  $Z_1$ , **821** and **822**, second via impedance  $Z_{via1}$ , **831** and **832**, second dividing impedance  $Z_2$ , **841** to **844**, and antenna impedance  $Z_L(\text{Ant})$ , **871** to **874** may be generated.

[0189] The second via impedance  $Z_{via1}$ , **831** and **832** may include 2-1st via impedance  $Z_{via2}$ , **831** and 2-2nd via impedance  $Z_{via2}$ , **832**.

[0190] The second dividing impedance  $Z_2$ , **841** to **844** may include 2-1st dividing impedance  $Z_2$ , **841** and 2-2nd dividing impedance  $Z_2$ , **842**.

[0191] The antenna impedance  $Z_L(\text{Ant})$ , **871** to **874** may include first antenna impedance  $Z_L(\text{Ant})$ , **871**, second antenna impedance  $Z_L(\text{Ant})$ , **872**, third antenna impedance  $Z_L(\text{Ant})$ , **873**, and fourth antenna impedance  $Z_L(\text{Ant})$ , **874**.

[0192] The 2-1st via impedance  $Z_{via2}$ , **831** may be generated in the 2-1st via hole **221a** and the 3-1st via hole **321**. The 2a-th via hole **221a** and the 3-1st via hole **321** may have 2-1st via impedance  $Z_{via2}$ , **831**.

[0193] The 2-2nd via impedance  $Z_{via2}$ , **832** may be generated in the 2c-th via hole **221c** and the 3-2nd via hole **322**. The 2c-th via hole **221c** and the 3-2nd via hole **322** may have 2-2nd via impedance  $Z_{via2}$ , **832**.

[0194] The 2-1st dividing impedance  $Z_2$ , **841** may be generated in the 4-1a-th dividing line **441a**. The 4-1a-th dividing line **441a** may have 2-1st dividing impedance  $Z_2$ , **841**.

[0195] The 2-2nd dividing impedance  $Z_2$ , **842** may be generated in the 4-1b-th dividing line **441b**. The 4-1b-th dividing line **441b** may have 2-2nd dividing impedance  $Z_2$ , **842**.

[0196] The 2-3rd dividing impedance  $Z_2$ , **843** may be generated in the 4-2a-th dividing line **442a**. The 4-2a-th dividing line **442a** may have 2-3rd dividing impedance  $Z_2$ , **843**.

[0197] The 2-4th dividing impedance  $Z_2$ , **844** may be generated in the 4-2b-th dividing line **442b**. The 4-2b-th dividing line **442b** may have 2-4th dividing impedance  $Z_2$ , **844**.

[0198] The first antenna impedance  $Z_L(\text{Ant})$ , **871** may be generated in a conductive line in which a signal flows from the 4-1a-th via hole **431a** to the first antenna **901**.

[0199] The second antenna impedance  $Z_L(\text{Ant})$ , **872** may be generated in a conductive line in which a signal flows from the 4-1c-th via hole **431c** to the second antenna **902**.

[0200] The third antenna impedance  $Z_L(\text{Ant})$ , **873** may be generated in a conductive line in which a signal flows from the 4-2a-th via hole **432a** to the third antenna **903**.

[0201] The fourth antenna impedance  $Z_L(\text{Ant})$ , **874** may be generated in a conductive line in which a signal flows from the 4-2c-th via hole **432c** to the fourth antenna **904**.

[0202] The second via impedance  $Z_{via2}$ , **831** and **832** may be determined based on at least one of distances of conductive lines in which the second dividing impedance  $Z_2$ , **841**

to **844**, the antenna impedance  $Z_L(\text{Ant})$ , **871** to **874**, and the antenna impedance  $Z_L(\text{Ant})$ , **871** to **874** are generated.

[0203] For example, the 2-1st via impedance  $Z_{via2}$ , **831** may be determined based on at least one of the 2-1st dividing impedance  $Z_2$ , **841**, the 2-2nd dividing impedance  $Z_2$ , **842**, the first antenna impedance  $Z_L(\text{Ant})$ , **871**, the second antenna impedance  $Z_L(\text{Ant})$ , **872**, a distance of a conductive line in which the first antenna impedance  $Z_L(\text{Ant})$ , **871** is generated, and a distance of a conductive line in which the second antenna impedance  $Z_L(\text{Ant})$ , **872** is generated.

[0204] For example, the 2-1st via impedance  $Z_{via2}$ , **831** may be determined based on a separation distance  $d_3$  between edges of the 2a-th via pad **221** and the 2a-th etching area **211a**.

[0205] The 2-1st via impedance  $Z_{via2}$ , **831** may be determined based on a separation distance  $d_3$  between edges of the 3-1st via pad **321** and the 3-1st etching area **311**.

[0206] The 2-1st via impedance  $Z_{via2}$ , **831** may be determined based on a separation distance  $d_3$  between edges of the 4-1b-th via pad **421b** and the 4-1c-th etching area **411c**.

[0207] The 2-4st via impedance  $Z_{via2}$ , **831** may be determined based on at least one of a separation distance  $d_3$  between edges of the 2a-th via pad **221** and the 2a-th etching area **211a**, a separation distance  $d_3$  between edges of the 3-1st via pad **321** and the 3-1st etching area **311**, and a separation distance  $d_3$  between edges of the 4-1b-th via pad **421b** and the 4-1c-th etching area **411c**.

[0208] The separation distance  $d_3$  between edges of the 2a-th via pad **221** and the 2a-th etching area **211a**, the separation distance  $d_3$  between edges of the 3-1st via pad **321** and the 3-1st etching area **311**, and the separation distance  $d_3$  between edges of the 4-1b-th via pad **421b** and the 4-1c-th etching area **411c** may be the same or different.

[0209] FIG. **13** is a conceptual diagram illustrating an antenna module **11** according to various embodiments.

[0210] With reference to FIG. **13**, the antenna module **11** may further include a sixth layer **600** and a seventh layer **700**.

[0211] The sixth layer **600** may be stacked on one surface of the fifth layer **500**. The sixth layer **600** may include a sixth etching area **610**, a sixth via pad **620**, and a sixth via hole **630**.

[0212] The seventh layer **700** may be stacked on one surface of the sixth layer **600**. The seventh layer **700** may include a seventh etching area **710** and a seventh via pad **720**.

[0213] For example, the sixth layer **600** may be the same as that illustrated in FIG. **14**. The seventh layer **700** may be the same as that illustrated in FIG. **15**.

[0214] FIG. **14** is a conceptual diagram illustrating a sixth layer **600** of an antenna module **1** according to various embodiments.

[0215] With reference to FIG. **14**, a sixth etching area **610** may be etched portions of the sixth layer **600**. For example, the sixth etching area **610** may be areas penetrating the fourth layer **600** in the z-axis direction.

[0216] The sixth etching area **610** may include a 6-1st etching area **611**, a 6-2nd etching area **612**, a 6-3rd etching area **613**, and a 6-4th etching area **614**.

[0217] The 6-1st etching area **611**, the 6-2nd etching area **612**, the 6-3rd etching area **613**, and the 6-4th etching area

**614** may be formed to be spaced apart from each other by a predetermined distance in the x-axis direction on the sixth layer **600**.

[0218] The 6-1st etching area **611** may include a 6-1a-th etching area **611a**, a 6-1b-th etching area **611b**, a 6-1c-th etching area **611**, a 6-1d-th etching area **611d**, and a 6-1e-th etching area **611e**.

[0219] The 6-1a-th etching area **611a**, the 6-1c-th etching area **611c**, and the 6-1e-th etching area **611e** may be formed to be spaced apart from each other by a predetermined distance in the x-axis direction on the sixth layer.

[0220] The 6-1b-th etching area **611b** may be formed between the 6-1a-th etching area **611a** and the 6-1c-th etching area **611c**.

[0221] The 6-1d-th etching area **611d** may be formed between the 6-1c-th etching area **611c** and the 6-1e-th etching area **611e**.

[0222] The 6-2nd etching area **612** may include a 6-2a-th etching area **612a**, a 6-2b-th etching area **612b**, a 6-2c-th etching area **612c**, a 6-2d-th etching area **612d**, and a 6-2e-th etching area **612e**.

[0223] The 6-2a-th etching area **612a**, the 6-2c-th etching area **612c**, and the 6-2e-th etching area **612e** may be formed to be spaced apart from each other by a predetermined distance in the x-axis direction on the sixth layer.

[0224] The 6-2b-th etching area **612b** may be formed between the 6-2a-th etching area **612a** and the 6-2c-th etching area **612c**.

[0225] The 6-2d-th etching area **612d** may be formed between the 6-2c-th etching area **612c** and the 6-2e-th etching area **612e**.

[0226] The 6-3th etching area **613** may include a 6-3a-th etching area **613a**, a 6-3b-th etching area **613b**, a 6-3c-th etching area **613c**, a 6-3d-th etching area **613d**, and a 6-3e-th etching area **613e**.

[0227] The 6-3a-th etching area **613a**, the 6-3c-th etching area **613c**, and the 6-3e-th etching area **613e** may be formed to be spaced apart from each other by a predetermined distance in the x-axis direction on the sixth layer.

[0228] The 6-3b-th etching area **613b** may be formed between the 6-3a-th etching area **613a** and the 6-3c-th etching area **613c**.

[0229] The 6-3d-th etching area **613d** may be formed between the 6-3c-th etching area **613c** and the 6-3e-th etching area **613e**.

[0230] The 6-4th etching area **614** may include a 6-4a-th etching area **614a**, a 6-4b-th etching area **614b**, a 6-4c-th etching area **614c**, a 6-4d-th etching area **614d**, and a 6-4e-th etching area **614e**.

[0231] The 6-4a-th etching area **614a**, the 6-4c-th etching area **614c**, and the 6-4e-th etching area **614e** may be formed to be spaced apart from each other by a predetermined distance in the x-axis direction on the sixth layer.

[0232] The 6-4b-th etching area **614b** may be formed between the 6-4a-th etching area **614a** and the 6-4c-th etching area **614c**.

[0233] The 6-4d-th etching area **614d** may be formed between the 6-4c-th etching area **614c** and the 6-4e-th etching area **614e**.

[0234] The sixth via pad **620** may include a 6-1st via pad **621**, a 6-2nd via pad **622**, a 6-3rd via pad **623**, and a 6-4th via pad **624**.

[0235] The 6-1st via pad **621** may be disposed in the 6-1st etching area **611**. For example, the 6-1st via pad **621** may be spaced apart from an edge of the 6-1st etching area **611** by a predetermined distance.

[0236] The 6-2nd via pad **622** may be disposed in the 6-2nd etching area **612**. For example, the 6-2nd via pad **622** may be spaced apart from an edge of the 6-2nd etching area **612** by a predetermined distance.

[0237] The 6-1th via pad **621** may include a 6-1a-th via pad **621a**, a 6-1b-th via pad **621b**, and a 6-1c-th via pad **621c**. A length of a width of each of the 6-1st via pads **621** may be the same or similar.

[0238] For example, the 6-1a-th via pad **621a** may be disposed in the 6-1a-th etching area **611a**. A length of a width of the 6-1a-th via pad **621a** may be smaller than that of the 6-1a-th etching area **611a**. For example, the 6-1a-th via pad **621a** may be spaced apart from an edge of the 6-1a-th etching area **611a** by a predetermined distance.

[0239] The 6-1b-th via pad **621b** may be disposed in the 6-1c-th etching area **611c**. A length of a width of the 6-1b-th via pad **621b** may be smaller than that of the 6-1c-th etching area **611c**. For example, the 6-1b-th via pad **621b** may be spaced apart from an edge of the 6-1c-th etching area **611c** by a predetermined distance. The 6-1b-th via pad **621b** may be electrically connected to the 5-1st via hole **531**. For example, one end of the 5-1st via hole **531** may be electrically connected to the other surface of the 6-1b-th via pad **621b**.

[0240] The 6-1e-th via pad **621c** may be disposed in the 6-1e-th etching area **611e**. A length of a width of the 6-1c-th via pad **621c** may be smaller than that of the 6-1e-th etching area **611e**. For example, the 6-1c-th via pad **621c** may be spaced apart from an edge of the 6-1e-th etching area **611e** by a predetermined distance.

[0241] The 6-2nd via pad **622** may include a 6-2a-th via pad **622a**, a 6-2b-th via pad **622b**, and a 6-2c-th via pad **622c**. A length of a width of each of the plurality of 6-2nd via pads **622** may be the same or similar.

[0242] For example, the 6-2a-th via pad **622a** may be disposed in the 6-2a-th etching area **612a**. A length of a width of the 6-2a-th via pad **622a** may be smaller than that of the 6-2a-th etching area **612a**. For example, the 6-2a-th via pad **622a** may be spaced apart from an edge of the 6-2a-th etching area **612a** by a predetermined distance.

[0243] The 6-2b-th via pad **622b** may be disposed in the 6-2c-th etching area **612c**. A length of a width of the 6-2b-th via pad **622b** may be smaller than that of the 6-2c-th etching area **612c**. For example, the 6-2b-th via pad **622b** may be spaced apart from an edge of the 6-2c-th etching area **612c** by a predetermined distance. The 6-2b-th via pad **622b** may be electrically connected to the 6-2nd via hole **632**. For example, one end of the 6-2nd via hole **632** may be electrically connected to the other surface of the 6-2b-th via pad **622b**.

[0244] The 6-2c-th via pad **622c** may be disposed in the 6-2e-th etching area **612e**. A length of a width of the 6-2c-th via pad **622c** may be smaller than that of the 6-2e-th etching area **612e**. For example, the 6-2c-th via pad **622c** may be spaced apart from an edge of the 6-2e-th etching area **612e** by a predetermined distance.

[0245] The 6-3rd via pad **623** may be disposed in the 6-3rd etching area **613**. For example, the 6-3rd via pad **623** may be spaced apart from an edge of the 6-3rd etching area **613** by a predetermined distance.

[0246] The 6-3rd via pad **623** may be disposed in the 6-3rd etching area **613**. For example, the 6-3rd via pad **623** may be spaced apart from an edge of the 6-3rd etching area **613** by a predetermined distance.

[0247] The 6-3rd via pad **623** may include a 6-3a-th via pad **623a**, a 6-3b-th via pad **623b**, and a 6-3c-th via pad **623c**. A length of a width of each of the 6-3rd via pads **623** may be the same or similar.

[0248] For example, the 6-3a-th via pad **623a** may be disposed in the 6-3a-th etching area **613a**. A length of a width of the 6-3a-th via pad **623a** may be smaller than that of the 6-3a-th etching area **613a**. For example, the 6-3a-th via pad **623a** may be spaced apart from an edge of the 6-3a-th etching area **613a** by a predetermined distance.

[0249] The 6-3b-th via pad **623b** may be disposed in the 6-3c-th etching area **613c**. A length of a width of the 6-3b-th via pad **623b** may be smaller than that of the 6-3c-th etching area **613c**. For example, the 6-3b-th via pad **623b** may be spaced apart from an edge of the 6-3c-th etching area **613c** by a predetermined distance. The 6-3b-th via pad **623b** may be electrically connected to the 5-3rd via hole **533**. For example, one end of the 5-3rd via hole **533** may be electrically connected to the other surface of the 6-3b-th via pad **623b**.

[0250] The 6-3c-th via pad **623c** may be disposed in the 6-3e-th etching area **613e**. A length of a width of the 6-3c-th via pad **623c** may be smaller than that of the 6-3e-th etching area **613e**. For example, the 6-3c-th via pad **623c** may be spaced apart from an edge of the 6-3e-th etching area **613e** by a predetermined distance.

[0251] The 6-4th via pad **624** may include a 6-4a-th via pad **624a**, a 6-4b-th via pad **624b**, and a 6-4c-th via pad **624c**. A length of a width of each of the plurality of 6-4th via pads **624** may be the same or a similar.

[0252] For example, the 6-4a-th via pad **624a** may be disposed in the 6-4a-th etching area **614a**. A length of a width of the 6-4a-th via pad **624a** may be smaller than that of the 6-4a-th etching area **614a**. For example, the 6-4a-th via pad **624a** may be spaced apart from an edge of the 6-4a-th etching area **614a** by a predetermined distance.

[0253] The 6-4b-th via pad **624b** may be disposed in the 6-4c-th etching area **614c**. A length of a width of the 6-4b-th via pad **624b** may be smaller than that of the 6-4c-th etching area **614c**. For example, the 6-4b-th via pad **624b** may be spaced apart from an edge of the 6-4c-th etching area **614c** by a predetermined distance. The 6-4b-th via pad **624b** may be electrically connected to the 6-4th via hole **634**. For example, one end of the 6-4th via hole **634** may be electrically connected to the other surface of the 6-4b-th via pad **624b**.

[0254] The 6-4c-th via pad **624c** may be disposed in the 6-4e-th etching area **614e**. A length of a width of the 6-4c-th via pad **624c** may be smaller than that of the 6-4e-th etching area **614e**. For example, the 6-4c-th via pad **624c** may be spaced apart from an edge of the 6-4e-th etching area **614e** by a predetermined distance.

[0255] A length of a width of each of the sixth via holes **630** may be smaller than that of each of the sixth via pads **620**. The sixth via hole **630** may include a 6-1a-th via hole **631a**, a 6-1b-th via hole **631b**, a 6-2a-th via hole **632a**, a 6-2b-th via hole **632b**, a 6-3a-th via hole **633a**, a 6-3b-th via hole **633b**, a 6-4a-th via hole **634a**, and a 6-4b-th via hole **634b**.

[0256] The 6-1a-th via hole **631a** may be disposed at one surface of the 6-1a-th via pad **621a**. A length of a width of the 6-1a-th via hole **631a** may be smaller than that of the 6-1a-th via pad **621a**.

[0257] The 6-1b-th via hole **631b** may be disposed at one surface of the 6-1c-th via pad **621c**. A length of a width of the 6-1b-th via hole **631b** may be smaller than that of the 6-1c-th via pad **621c**.

[0258] The 6-2a-th via hole **632a** may be disposed at one surface of the 6-2a-th via pad **622a**. A length of a width of the 6-2a-th via hole **632a** may be smaller than that of the 6-2a-th via pad **622a**.

[0259] The 6-2b-th via hole **632b** may be disposed at one surface of the 6-2c-th via pad **622c**. A length of a width of the 6-2b-th via hole **632b** may be smaller than that of the 6-2c-th via pad **622c**.

[0260] The 6-3a-th via hole **633a** may be disposed at one surface of the 6-3a-th via pad **623a**. A length of a width of the 6-3a-th via hole **633a** may be smaller than that of the 6-3a-th via pad **623a**.

[0261] The 6-3b-th via hole **633b** may be disposed at one surface of the 6-3c-th via pad **623c**. A length of a width of the 6-3b-th via hole **633b** may be smaller than that of the 6-3c-th via pad **623c**.

[0262] The 6-4a-th via hole **634a** may be disposed at one surface of the 6-4a-th via pad **624a**. A length of a width of the 6-4a-th via hole **634a** may be smaller than that of the 6-4a-th via pad **624a**.

[0263] The 6-4b-th via hole **634b** may be disposed at one surface of the 6-4c-th via pad **624c**. A length of a width of the 6-4b-th via hole **634b** may be smaller than that of the 6-4c-th via pad **624c**.

[0264] The sixth dividing line **640** may include a 6-1a-th dividing line **641a**, a 6-1b-th dividing line **641b**, a 6-2a-th dividing line **642a**, a 6-2b-th dividing line **642b**, a 6-3a-th dividing line **643a**, a 6-3b-th dividing line **643b**, a 6-4a-th dividing line **644a**, and a 6-4b-th dividing line **644b**.

[0265] The 6-1a-th dividing line **641a** may be disposed between the 6-1a-th via pad **621a** and the 6-1b-th via pad **621b**. For example, one end of the 6-1a-th dividing line **641a** may be electrically connected to the 6-1a-th via pad **621a**. The other end of the 6-1a-th dividing line **641a** may be electrically connected to the 6-1b-th via pad **621b**.

[0266] The 6-1a-th dividing line **641a** may be disposed in the 6-1b-th etching area **611b**. A length of a width of the 6-1a-th dividing line **641a** may be smaller than that of the 6-1b-th etching area **611b**. For example, the 6-1a-th dividing line **641a** may be spaced apart from the 6-1b-th etching area **611b** by a predetermined distance.

[0267] The 6-1b-th dividing line **641b** may be disposed between the 6-1b-th via pad **621b** and the 6-1c-th via pad **621c**. For example, one end of the 6-1b-th dividing line **641b** may be electrically connected to the 6-1b-th via pad **621b**. The other end of the 6-1b-th dividing line **641b** may be electrically connected to the 6-1c-th via pad **621c**.

[0268] The 6-1b-th dividing line **641b** may be disposed in the 6-1d-th etching area **611d**. A length of a width of the 6-1b-th dividing line **641b** may be smaller than that of the 6-1d-th etching area **611d**. For example, the 6-1b-th dividing line **641b** may be spaced apart from the 6-1d-th etching area **611d** by a predetermined distance.

[0269] The 6-2a-th dividing line **642a** may be disposed between the 6-2a-th via pad **622a** and the 6-2b-th via pad **622b**. For example, one end of the 6-2a-th dividing line **642a**

may be electrically connected to the 6-2a-th via pad **622a**. The other end of the 6-2a-th dividing line **642a** may be electrically connected to the 6-2b-th via pad **622b**.

[0270] The 6-2a-th dividing line **642a** may be disposed in the 6-2b-th etching area **612b**. A length of a width of the 6-2a-th dividing line **642a** may be smaller than that of the 6-2b-th etching area **612b**. For example, the 6-2a-th dividing line **642a** may be spaced apart from the 6-2b-th etching area **612b** by a predetermined distance.

[0271] The 6-2b-th dividing line **642b** may be disposed between the 6-2b-th via pad **622b** and the 6-2c-th via pad **622c**. For example, one end of the 6-2b-th dividing line **642b** may be electrically connected to the 6-2b-th via pad **622b**. The other end of the 6-2b-th dividing line **642b** may be electrically connected to the 6-2c-th via pad **622c**.

[0272] The 6-2b-th dividing line **642b** may be disposed in the 6-2d-th etching area **612d**. A length of a width of the 6-2b-th dividing line **642b** may be smaller than that of the 6-2d-th etching area **612d**. For example, the 6-2b-th dividing line **642b** may be spaced apart from the 6-2d-th etching area **612d** by a predetermined distance.

[0273] The 6-3a-th dividing line **643a** may be disposed between the 6-3a-th via pad **623a** and the 6-3b-th via pad **623b**. For example, one end of the 6-3a-th dividing line **643a** may be electrically connected to the 6-3a-th via pad **623a**. The other end of the 6-3a-th dividing line **643a** may be electrically connected to the 6-3b-th via pad **623b**.

[0274] The 6-3a-th dividing line **643a** may be disposed in the 6-3b-th etching area **613b**. A length of a width of the 6-3a-th dividing line **643a** may be smaller than that of the 6-3b-th etching area **613b**. For example, the 6-3a-th dividing line **643a** may be spaced apart from the 6-3b-th etching area **613b** by a predetermined distance.

[0275] The 6-3b-th dividing line **643b** may be disposed between the 6-3b-th via pad **623b** and the 6-3c-th via pad **623c**. For example, one end of the 6-3b-th dividing line **643b** may be electrically connected to the 6-3b-th via pad **623b**. The other end of the 6-3b-th dividing line **643b** may be electrically connected to the 6-3c-th via pad **623c**.

[0276] The 6-3b-th dividing line **643b** may be disposed in the 6-3d-th etching area **613d**. A length of a width of the 6-3b-th dividing line **643b** may be smaller than that of the 6-3d-th etching area **613d**. For example, the 6-3b-th dividing line **643b** may be spaced apart from the 6-3d-th etching area **613d** by a predetermined distance.

[0277] The 6-4a-th dividing line **644a** may be disposed between the 6-4a-th via pad **624a** and the 6-4b-th via pad **624b**. For example, one end of the 6-4a-th dividing line **644a** may be electrically connected to the 6-4a-th via pad **624a**. The other end of the 6-4a-th dividing line **644a** may be electrically connected to the 6-4b-th via pad **624b**.

[0278] The 6-4a-th dividing line **644a** may be disposed in the 6-4b-th etching area **614b**. A length of a width of the 6-4a-th dividing line **644a** may be smaller than that of the 6-4b-th etching area **614b**. For example, the 6-4a-th dividing line **644a** may be spaced apart from the 6-4b-th etching area **614b** by a predetermined distance.

[0279] The 6-4b-th dividing line **644b** may be disposed between the 6-4b-th via pad **624b** and the 6-4c-th via pad **624c**. For example, one end of the 6-4b-th dividing line **644b** may be electrically connected to the 6-4b-th via pad **624b**. The other end of the 6-4b-th dividing line **644b** may be electrically connected to the 6-4c-th via pad **624c**.

[0280] The 6-4b-th dividing line **644b** may be disposed in the 6-4d-th etching area **614d**. A length of a width of the 6-4b-th dividing line **644b** may be smaller than that of the 6-4d-th etching area **614d**. For example, the 6-4b-th dividing line **644b** may be spaced apart from the 6-4d-th etching area **614d** by a predetermined distance.

[0281] FIG. 15 is a conceptual diagram illustrating a seventh layer **700** of an antenna module **11** according to various embodiments.

[0282] With reference to FIG. 15, a seventh etching area **710** may be an etched portion of the seventh layer **700**. For example, the seventh etching area **710** may be an area penetrating the seventh layer **700** in the z-axis direction.

[0283] The seventh etching area **710** may include a 7-1st etching area **711**, a 7-2nd etching area **712**, a 7-3rd etching area **713**, a 7-4th etching area **714**, a 7-5th etching area **715**, a 7-6th etching area **716**, a 7-7th etching area **717**, and a 7-8th etching area **718**.

[0284] The 7-1st etching area **711**, the 7-2nd etching area **712**, the 7-3rd etching area **713**, the 7-4th etching area **714**, the 7-5th etching area **715**, the 7-6th etching area **716**, the 7-7th etching area **717**, and the 7-8th etching area **718** may be formed to be spaced apart from each other by a predetermined distance in the x-axis direction on the seventh layer **700**.

[0285] The plurality of seventh via pads **720** may include a 7-1st via pad **721**, a 7-2nd via pad **722**, a 7-3rd via pad **723**, a 7-4th via pad **724**, a 7-5th via pad **725**, a 7-6th via pad **726**, a 7-7th via pad **727**, and a 7-8th via pad **728**.

[0286] The 7-1st via pad **721** may be disposed in the 7-1st etching area **711**. A length of a width of the 7-1st via pad **721** may be smaller than that of the 7-1st etching area **711**. For example, the 7-1st via pad **721** may be spaced apart from an edge of the 7-1st etching area **711** by a predetermined distance. The 7-1th via pad **721** may be electrically connected to the 6-1a-th via hole **631a**. For example, one end of the 6-1a-th via hole **631a** may be electrically connected to the other surface of the 7-1st via pad **721**.

[0287] The 7-2nd via pad **722** may be disposed in the 7-2nd etching area **712**. A length of a width of the 7-2nd via pad **722** may be smaller than that of the 7-2nd etching area **712**. For example, the 7-2nd via pad **722** may be spaced apart from an edge of the 7-2nd etching area **712** by a predetermined distance. The 7-2nd via pad **722** may be electrically connected to the 6-1b-th via hole **631b**. For example, one end of the 6-1b-th via hole **631b** may be electrically connected to the other surface of the 7-2nd via pad **722**.

[0288] The 7-3rd via pad **723** may be disposed in the 7-3rd etching area **713**. A length of a width of the 7-3rd via pad **723** may be smaller than that of the 7-3rd etching area **713**. For example, the 7-3rd via pad **723** may be spaced apart from an edge of the 7-3rd etching area **713** by a predetermined distance. The 7-3rd via pad **723** may be electrically connected to the 6-2a-th via hole **632a**. For example, one end of the 6-2a-th via hole **632a** may be electrically connected to the other surface of the 7-3rd via pad **723**.

[0289] The 7-4th via pad **724** may be disposed in the 7-4th etching area **714**. A length of a width of the 7-4th via pad **724** may be smaller than that of the 7-4th etching area **714**. For example, the 7-4th via pad **724** may be spaced apart from an edge of the 7-4th etching area **714** by a predetermined distance. The 7-4th via pad **724** may be electrically connected to the 6-2b-th via hole **632b**. For example, one end of



the 6-2b-th via hole **632b** may be electrically connected to the other surface of the 7-4th via pad **724**.

**[0290]** The 7-5th via pad **725** may be disposed in the 7-5th etching area **715**. A length of a width of the 7-5th via pad **725** may be smaller than that of the 7-5th etching area **715**. For example, the 7-5th via pad **725** may be spaced apart from an edge of the 7-5th etching area **715** by a predetermined distance. The 7-5th via pad **725** may be electrically connected to the 6-3a-th via hole **631a**. For example, one end of the 6-3a-th via hole **633a** may be electrically connected to the other surface of the 7-5th via pad **725**.

**[0291]** The 7-6th via pad **726** may be disposed in the 7-6th etching area **716**. A length of a width of the 7-6th via pad **726** may be smaller than that of the 7-6th etching area **716**. For example, the 7-6th via pad **726** may be spaced apart from an edge of the 7-6th etching area **716** by a predetermined distance. The 7-6th via pad **726** may be electrically connected to the 6-3b-th via hole **633b**. For example, one end of the 6-3b-th via hole **633b** may be electrically connected to the other surface of the 7-6th via pad **726**.

**[0292]** The 7-7th via pad **727** may be disposed in the 7-7th etching area **717**. A length of a width of the 7-7th via pad **727** may be smaller than that of the 7-7th etching area **717**. For example, the 7-7th via pad **727** may be spaced apart from an edge of the 7-7th etching area **717** by a predetermined distance. The 7-7th via pad **727** may be electrically connected to the 6-4a-th via hole **634a**. For example, one end of the 6-4a-th via hole **634a** may be electrically connected to the other surface of the 7-7th via pad **727**.

**[0293]** The 7-8th via pad **728** may be disposed in the 7-8th etching area **718**. A length of a width of the 7-8th via pad **728** may be smaller than that of the 7-8th etching area **718**. For example, the 7-8th via pad **728** may be spaced apart from an edge of the 7-8th etching area **718** by a predetermined distance. The 7-8th via pad **728** may be electrically connected to the 6-4b-th via hole **634b**. For example, one end of the 6-4b-th via hole **634b** may be electrically connected to the other surface of the 7-8th via pad **728**.

**[0294]** The plurality of antennas **901** to **908** may be electrically connected to the plurality of seventh via pads **720**. For example, the first antenna **901** may be electrically connected to one surface of the 7-1st via pad **721**. The second antenna **902** may be electrically connected to one surface of the 7-2nd via pad **722**. The third antenna **903** may be electrically connected to one surface of the 7-3rd via pad **723**. The fourth antenna **904** may be electrically connected to one surface of the 7-4th via pad **724**. The fifth antenna **905** may be electrically connected to one surface of the 7-5th via pad **725**. The sixth antenna **906** may be electrically connected to one surface of the 7-6th via pad **726**. The seventh antenna **907** may be electrically connected to one surface of the 7-7th via pad **727**. The eighth antenna **908** may be electrically connected to one surface of the 7-8th via pad **728**.

**[0295]** In the specific embodiments of the disclosure described above, components included in the disclosure were expressed in the singular or plural according to presented specific embodiments. However, the singular or plural expression is appropriately selected for a situation presented for convenience of description, and the disclosure is not limited to the singular or plural components, and even if a component is represented in the plural, it may be formed with the singular, or even if a component is represented in the singular, it may be formed with the plural.

**[0296]** In the detailed description of the disclosure, although specific embodiments have been described, various modifications are possible without departing from the scope of the disclosure. Therefore, the scope of the disclosure should not be limited to the described embodiments and should be defined by the claims described below as well as by those equivalent to the claims.

#### INDUSTRIAL APPLICABILITY

**[0297]** The disclosure may be used in the electronics industry and information communication industry.

1. An antenna module, comprising:

a first layer including a first etching area, a first via pad disposed to be spaced apart from an edge of the first etching area, and a first via hole disposed at one surface of the first via pad;

a second layer stacked on one surface of the first layer and including a second etching area, a plurality of second via pads disposed to be spaced apart from an edge of the second etching area, a plurality of second via holes disposed at one surface of the plurality of second via pads, and a plurality of second dividing lines configured to electrically connect the plurality of second via pads;

a third layer stacked on one surface of the second layer and including a plurality of third etching areas, a plurality of third via pads disposed to be spaced apart from an edge of the plurality of third etching areas, and a plurality of third via holes disposed at one surface of the plurality of third via pads;

a fourth layer stacked on one surface of the third layer and including a plurality of fourth etching areas, a plurality of fourth pads disposed to be spaced apart from edges of the plurality of fourth etching areas, a plurality of fourth via holes disposed at one surface of the plurality of fourth via pads, and a plurality of fourth dividing lines;

a fifth layer stacked on one surface of the fourth layer and including a plurality of fifth etching areas and a plurality of fifth via pads disposed to be spaced apart from edges of the plurality of fifth etching areas; and

a plurality of antennas electrically connected to the plurality of fifth via pads.

2. The antenna module of claim 1, wherein the plurality of second via pads comprise a 2a-th via pad, a 2b-th via pad, and a 2c-th via pad.

3. The antenna module of claim 2, wherein one end of the first via hole is electrically connected to the other end of the 2b-th via pad, and

the other end of the first via hole is electrically connected to one end of the first via pad.

4. The antenna module of claim 1, wherein the plurality of second via holes comprise a 2a-th via hole and a 2b-th via hole, and

the plurality of third via pads comprise a 3a-th via pad and a 3b-th via pad.

5. The antenna module of claim 4, wherein one end of the 2a-th via hole is electrically connected to the other end of the 3a-th via pad, and

the other end of the 2a-th via hole is electrically connected to one end of the 2a-th via pad.

6. The antenna module of claim 4, wherein one end of the 2b-th via hole is electrically connected to the other end of the 3b-th via pad, and

the other end of the 2b-th via hole is electrically connected to one end of the 2c-th via pad.

7. The antenna module of claim 1, wherein the plurality of second dividing lines comprise a 2a-th dividing line and a 2b-th dividing line.

8. The antenna module of claim 7, wherein one end of the 2a-th dividing line is electrically connected to the 2a-th via pad, and

the other end of the 2a-th dividing line is electrically connected to the 2b-th via pad.

9. The antenna module of claim 7, wherein one end of the 2b-th dividing line is electrically connected to the 2b-th via pad, and

the other end of the 2b-th dividing line is electrically connected to the 2c-th via pad.

10. The antenna module of claim 1, wherein the plurality of third via holes further comprise a 3a-th via hole and a 3b-th via hole, and

the plurality of fourth via pads comprise a 4a-th via pad, a 4b-th via pad, a 4c-th via pad, a 4d-th via pad, a 4e-th via pad, and a 4f-th via pad.

11. The antenna module of claim 10, wherein one end of the 3a-th via hole is electrically connected to the other end of the 4b-th via pad, and

the other end of the 3a-th via hole is electrically connected to one end of the 3a-th via pad.

12. The antenna module of claim 10, wherein one end of the 3b-th via hole is electrically connected to the other end of the 4e-th via pad, and

the other end of the 3b-th via hole is electrically connected to one end of the 3b-th via pad.

13. The antenna module of claim 1, wherein the plurality of fourth via holes further comprise a 4a-th via hole, a 4b-th via hole, a 4c-th via hole, and a 4d-th via hole, and the fifth via pad comprises a 5a-th via pad, a 5b-th via pad, a 5c-th via pad, and a 5d-th via pad.

14. The antenna module of claim 13, wherein one end of the 4a-th via hole is electrically connected to the other end of the 5a-th via pad,

the other end of the 4a-th via hole is electrically connected to one end of the 4a-th via pad,

one end of the 4b-th via hole is electrically connected to the other end of the 5b-th via pad,

the other end of the 4b-th via hole is electrically connected to one end of the 4c-th via pad,

one end of the 4c-th via hole is electrically connected to the other end of the 5c-th via pad,

the other end of the 4c-th via hole is electrically connected to one end of the 4d-th via pad,

one end of the 4d-th via hole is electrically connected to the other end of the 5d-th via pad, and

the other end of the 4d-th via hole is electrically connected to one end of the 4f-th via pad.

15. The antenna module of claim 1, wherein the plurality of fourth dividing lines comprise a 4a-th dividing line, a 4b-th dividing line, a 4c-th dividing line, and a 4d-th dividing line.

\* \* \* \* \*