



US 20140294489A1

(19) **United States**

(12) **Patent Application Publication**
SAKAI

(10) **Pub. No.: US 2014/0294489 A1**

(43) **Pub. Date: Oct. 2, 2014**

(54) **MEMBER JOINING METHOD AND MEMBER JOINING STRUCTURE**

Publication Classification

(71) Applicant: **Fuji Jukogyo Kabushiki Kaisha**, Tokyo (JP)

(51) **Int. Cl.**
F16B 5/08 (2006.01)

(72) Inventor: **Kensuke SAKAI**, Tokyo (JP)

(52) **U.S. Cl.**
CPC **F16B 5/08** (2013.01)
USPC **403/267; 29/428**

(73) Assignee: **Fuji Jukogyo Kabushiki Kaisha**, Tokyo (JP)

(57) **ABSTRACT**

(21) Appl. No.: **14/221,206**

A member joining method includes the steps of forming an opening in an intermediate member composed of one part or at least two superposed parts, embedding an insert member formed of metal in the opening, placing a skin member formed of metal on an outer surface of the intermediate member such that the intermediate member is held on an inner side of the skin member, and joining the skin member to the insert member.

(22) Filed: **Mar. 20, 2014**

(30) **Foreign Application Priority Data**

Mar. 27, 2013 (JP) 2013-066056

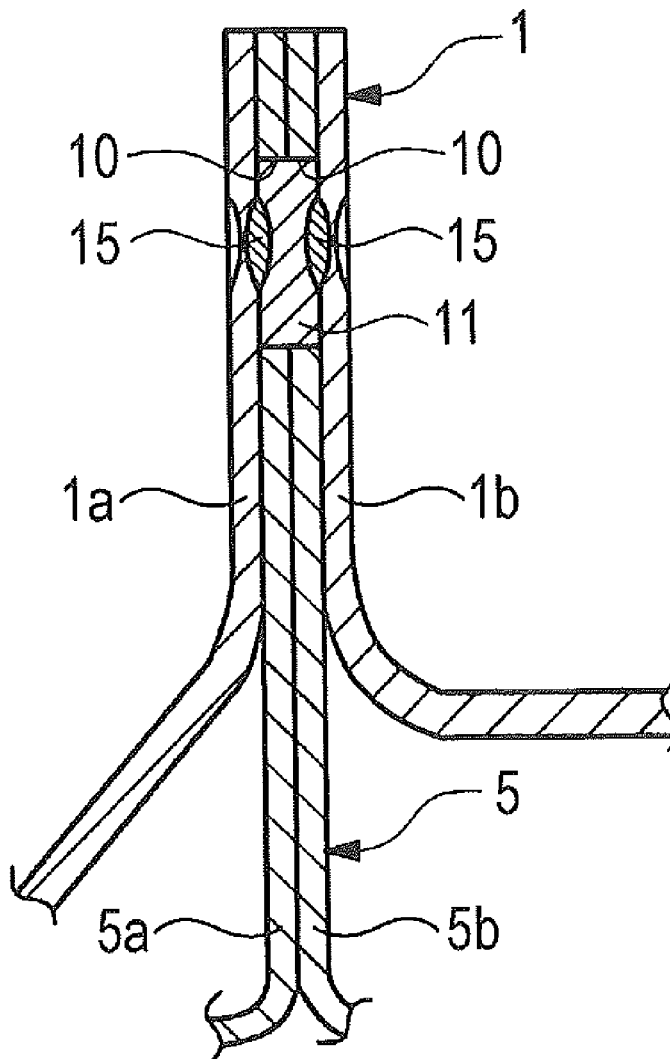

FIG. 1

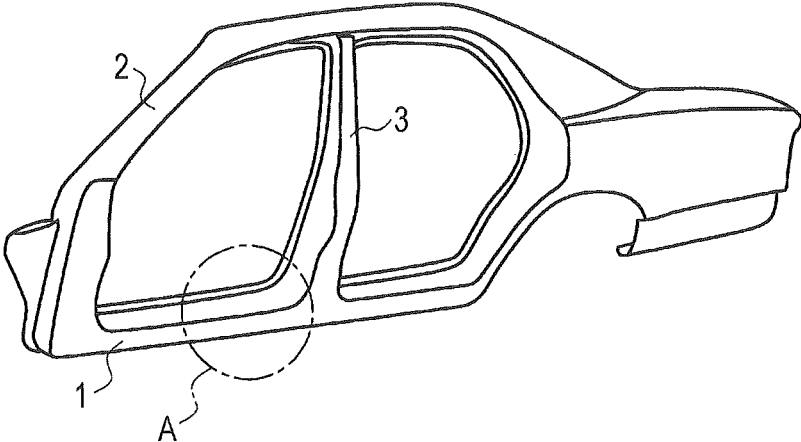

FIG. 2

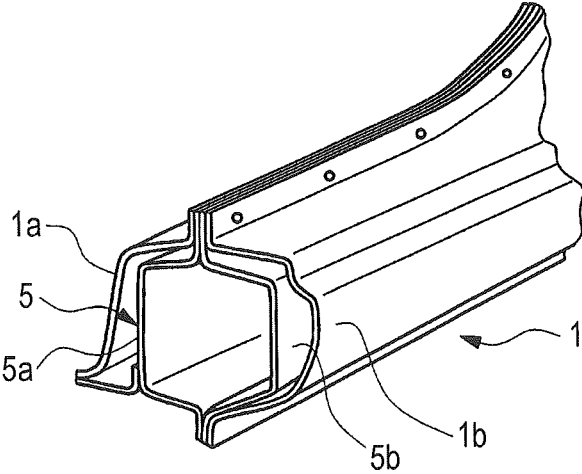

FIG. 3

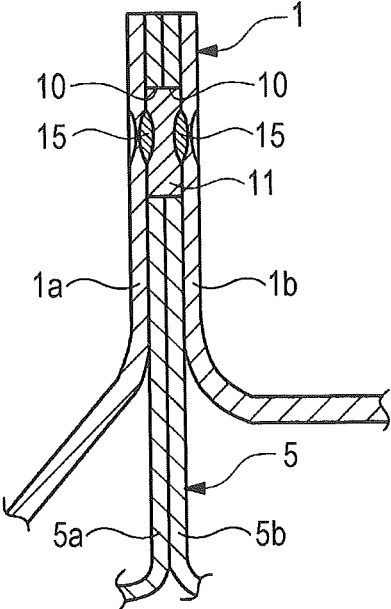

FIG. 4

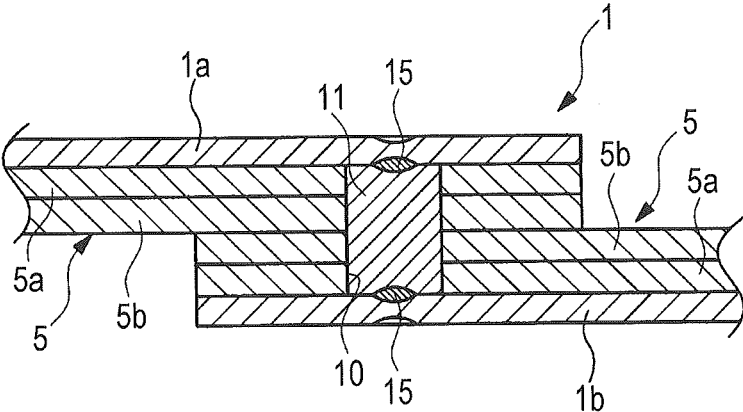

FIG. 5A

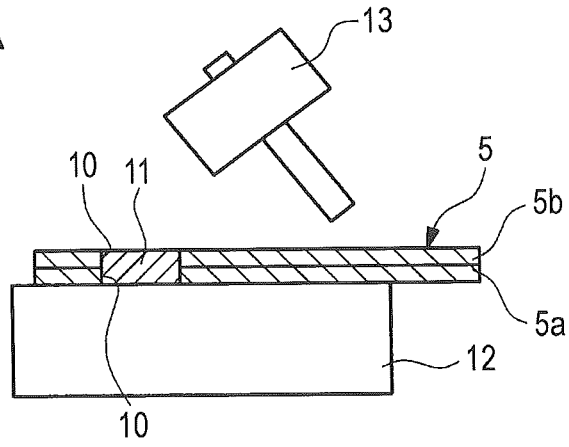

FIG. 5B

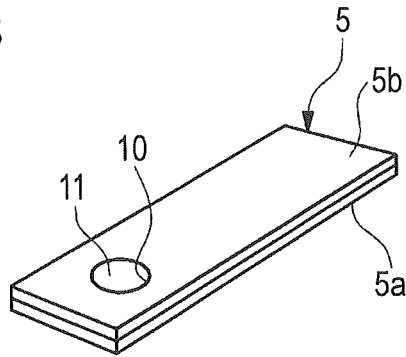

FIG. 5C

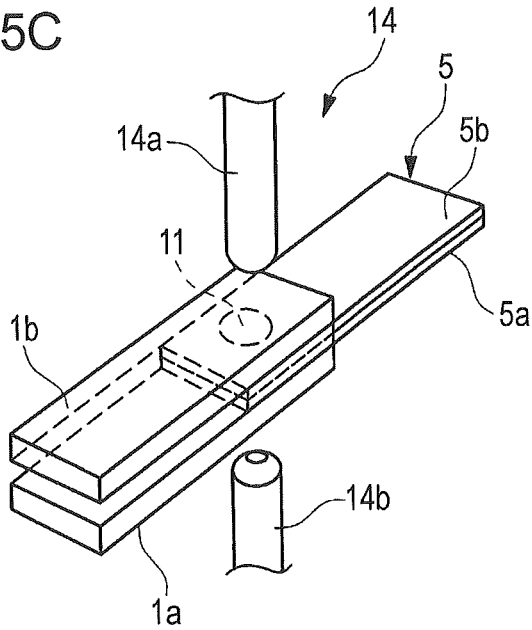
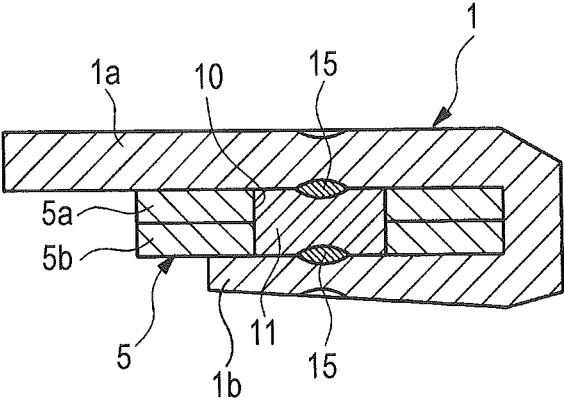

FIG. 6



MEMBER JOINING METHOD AND MEMBER JOINING STRUCTURE

CROSS-REFERENCES TO RELATED APPLICATIONS

[0001] The present application claims priority from Japanese Patent Application No. 2013-066056 filed on Mar. 27, 2013, the entire contents of which are hereby incorporated by reference.

BACKGROUND

[0002] 1. Technical Field

[0003] The present invention relates to a member joining method and a member joining structure, and more particularly, to a member joining method and a member joining structure using resistance spot welding.

[0004] 2. Related Art

[0005] In a joining method and a joining structure used in an automotive body welding line, three or less sheets are normally welded in order to ensure stable quality of resistance spot welding (for example, see Japanese Unexamined Patent Application Publication No. 2012-66795). For this reason, when four or more sheets are welded, for example, a predetermined joint portion is cut out to obtain a structure for welding three sheets.

[0006] Different metal materials are often welded in a basic member joining structure, and an intermetallic compound is sometimes produced between the different metal materials. Hence, it is difficult to obtain a member joining method and a member joining structure that ensures sufficient strength. For this reason, the member joining structure actually depends on mechanical fastening such as riveting.

[0007] However, in conventional joining structures and methods, when a cutout portion is formed by cutting out a predetermined joint portion, if external force is applied by a collision or for other reasons, a trouble such as deformation originating from the cutout portion is likely to occur. For this reason, the sheet thickness and material have to be changed to avoid such trouble.

[0008] In riveting, which is a joining method, a special apparatus and rivets, which are consumer goods, are necessary. This causes new problems in the production line and cost.

SUMMARY OF THE INVENTION

[0009] It is an object of the present invention to provide a member joining method and a member joining structure that allow three or more sheets to be welded easily.

[0010] A member joining method according to an aspect of the present invention includes the steps of forming an opening in an intermediate member composed of one part or at least two superposed parts, embedding an insert member formed of metal in the opening, placing a skin member formed of metal on an outer surface of the intermediate member such that the intermediate member is held on an inner side of the skin member, and joining the skin member to the insert member.

[0011] The insert member may be formed by an offcut of the skin member.

[0012] A member joining structure according to another aspect of the present invention includes an intermediate member composed of one part or at least two superposed parts and having an opening, a skin member formed of metal and disposed on an outer surface of the intermediate member such

that the intermediate member is held on an inner side of the skin member, and an insert member formed of metal and embedded in the opening.

[0013] The insert member may be formed by an offcut of the skin member.

BRIEF DESCRIPTION OF THE DRAWINGS

[0014] FIG. 1 is a perspective view of a side body structure of an vehicle according to an implementation of the present invention;

[0015] FIG. 2 is a cross-sectional view illustrating a cross-sectional structure of a section A in FIG. 1;

[0016] FIG. 3 is an enlarged principal cross-sectional view illustrating an example of a member joining structure;

[0017] FIG. 4 is an enlarged principal cross-sectional view illustrating another example of a member joining structure;

[0018] FIGS. 5A to 5C illustrate a member joining method; and

[0019] FIG. 6 is an enlarged principal cross-sectional view illustrating another example of a member joining structure.

DETAILED DESCRIPTION

[0020] An implementation of the present invention will be described in detail below with reference to the drawings.

[0021] As illustrated in FIG. 1, a side body structure of an vehicle includes a side sill 1 serving as the skin member extending in a front-rear direction in a side part of the vehicle body, a hinge pillar 2 extending upward from a front end portion of the side sill 1, and a center pillar 3 extending upward from a center portion of the side sill 1. In the side sill 1, the hinge pillar 2, and the center pillar 3, a side sill reinforcement 5 (see FIG. 2), a hinge pillar reinforcement (not illustrated), and a center pillar reinforcement (not illustrated) are disposed, respectively, as intermediate members.

[0022] As illustrated in FIG. 2, the side sill 1 serving as the skin member includes a side sill inner portion 1a and a side sill outer portion 1b. The side sill reinforcement 5 disposed as the intermediate member in the side sill 1 includes an inner reinforcement 5a and an outer reinforcement 5b.

[0023] The side sill inner portion 1a and the side sill outer portion 1b are each formed by a steel sheet, whereas the inner reinforcement 5a and the outer reinforcement 5b are each formed of a high-strength lightweight material, such as either one of an aluminum alloy and a carbon fiber reinforced composite material, in order to achieve greater strength and lighter weight in the vehicle body structure.

[0024] In order to join the four members, namely, the side sill inner portion 1b, the side sill outer portion 1b, the inner reinforcement 5a, and the outer reinforcement 5b not by mechanical fastening such as riveting, but by resistance spot welding, this implementation adopts a member joining structure illustrated in FIG. 3.

[0025] In this member joining structure, the inner reinforcement 5a and the outer reinforcement 5b which are made of at least two superposed intermediate members formed of either one of metal (for example, an aluminum alloy) and non-metal (for example, a carbon fiber reinforced composite material) each have an opening 10 formed by circular holes or apertures. In the openings 10, an insert member 11 shaped like either one of a disk and coin is embedded. The insert member 11 is formed of the same metal as that of the side sill 1 serving as the skin member (for example, a steel material).

[0026] Basically, it is preferable that the thickness of the insert member 11 should be equal to the sum of the thickness of the inner reinforcement 5a and the thickness of the outer reinforcement 5b in the side sill reinforcement 5. Alternatively, the thickness of the insert member 11 may be set to be slightly more than the sum of the thicknesses of the inner reinforcement 5a and the outer reinforcement 5b in the side sill reinforcement 5, and protruding portions of the insert member 11 protruding from outer surfaces of the inner reinforcement 5a and the outer reinforcement 5b may be removed by being beaten with a hammer 13, as illustrated in FIG. 5A.

[0027] If the insert member 11 is simply fitted in the circular openings 10, it may come off the opening 10. Accordingly, the outer diameter of the insert member 11 is preferably set to be slightly more than the inner diameter of the openings 10. The inner reinforcement 5a and the outer reinforcement 5b are placed one on the other on an anvil 12, as illustrated in FIG. 5A, and a single insert member 11 is driven into both the circular openings 10 of the inner and outer reinforcements 5a and 5b with the hammer 13 to apply plastic deformation force to the insert member 11. Thus, the insert member 11 is fitted and held in the openings 10 by compressive stress (see FIG. 5B).

[0028] As illustrated in FIG. 5C, the side sill inner portion 1a and the side sill outer portion 1b which are formed of metal, such as steel sheets, are contacted with the outer surfaces of the inner reinforcement 5a and the outer reinforcement 5b serving as the intermediate members, respectively, such that the inner reinforcement 5a and the outer reinforcement 5b are held between the side sill inner portion 1a and the side sill outer portion 1b. Further, as illustrated in FIG. 5C, these members are placed between opposed electrodes 14a and 14b in a resistance spot welding apparatus 14, and outer surfaces of the side sill inner portion 1a and the side sill outer portion 1b are clamped between the electrodes 14a and 14b. In this state, resistance spot welding is performed by applying voltage between the electrodes 14a and 14b.

[0029] The insert member 11 is set such that the center of the insert member 11 is located on a center line between the electrodes 14a and 14b in the resistance spot welding apparatus 14, the outer surfaces of the side sill inner portion 1a and the side sill outer portion 1b are clamped between the electrodes 14a and 14b, and resistance spot welding is performed by applying high voltage between the electrodes 14a and 14b. Resistance spot welding is performed to join the side sill inner portion 1a and the side sill outer portion 1b to the insert member 11.

[0030] Thus, as illustrated in FIG. 3, the side sill inner portion 1a and the side sill outer portion 1b are fixed integrally to the insert member 11 at welded portions 15. Hence, it is possible to provide a member joining structure that allows three or more (four in the implementation) sheet members to be easily welded without forming a cutout portion.

[0031] The insert member 11 is formed by an offcut of the side sill 1. Since the offcut of the side sill 1 can thus be used as the insert member 11, it can be utilized effectively. This leads to cost reduction.

[0032] Next, a member joining method will be described. In this member joining method, first, circular openings 10 are formed in an inner reinforcement 5a and an outer reinforcement 5b of an intermediate member (side sill reinforcement) 5 that is composed of one or at least two superposed metallic or nonmetallic members (first step).

[0033] After the first step, as illustrated in FIGS. 5A and 5B, a circular insert member 11 formed of metal is driven into the circular openings 10 with a hammer 13 (second step).

[0034] After the second step, a side sill inner portion 1a and a side sill outer portion 1b, which form a metallic skin member, are placed on outer surfaces of the inner reinforcement 5a and the outer reinforcement 5b so that the intermediate member 5 is held therebetween (third step).

[0035] After the third step, the side sill inner portion 1a and the side sill outer portion 1b serving as the skin member are joined to the insert member 11 by resistance spot welding (fourth step).

[0036] According to this member joining method including the first to fourth steps, three or more (four in the implementation) sheets (members) can be easily welded without forming a cutout portion. Therefore, unlike riveting, a special apparatus and rivets which are consumer goods are unnecessary, and an existing welding apparatus can be used. Hence, an existing production line can be utilized without any change. This reduces equipment cost.

[0037] The present invention is not limited to the above-described implementation, and various changes in design can be made within the scope of the invention. For example, while the side sill reinforcement 5 is composed of two intermediate members 5a and 5b in the implementation illustrated in FIG. 3, it may be composed of three intermediate members, or four intermediate members, as illustrated in FIG. 4. That is, the number of intermediate members is not limited. While the openings 10 are circular in the implementation, the shape of the openings 10 is not limited thereto. For example, the openings 10 may have any one of elliptical, triangular, rectangular, and polygonal shapes.

[0038] In a side sill 1 serving as the skin member in an example illustrated in FIG. 4, an inner reinforcement 5a and an outer reinforcement 5b are stacked on each of a side sill inner portion 1a and a side sill outer portion 1b, and the side sill inner portion 1a and the side sill outer portion 1b extend in opposite directions (a leftward direction and a rightward direction). In FIG. 4, components similar to those in FIG. 3 are denoted by the same reference numerals, and descriptions thereof are skipped.

[0039] FIG. 6 is an enlarged principal cross-sectional view illustrating another example of a member joining structure. As illustrated in FIG. 6, a side sill 1 serving as the skin member does not always need to be composed of two sheets, and a single side sill 1 may be folded back to have a U-shaped or angular U-shaped cross section such that a side sill inner portion 1a and a side sill outer portion 1b are opposed to each other.

[0040] While resistance spot welding is preferably used to join the skin member and the insert member, other joining methods, for example, either one of laser welding and friction stir welding may be used.

[0041] While the inner reinforcement 5a and the outer reinforcement 5b of the side sill reinforcement 5 are formed of a high-strength lightweight material, such as either one of an aluminum alloy and a carbon fiber reinforced composite material, in the above-described implementation, they may be formed of the same steel sheets as the side sill inner portion 1a and the side sill outer portion 1b. In this case, it is preferable to embed an insert member 11 formed by a steel sheet in openings 10 formed in the inner reinforcement 5a and the outer reinforcement 5b. That is, when multiple steel sheets are subjected to spot welding while being clamped between the

electrodes **14a** and **14b** of the resistance spot welding apparatus **14** that are located on both outer sides of the steel sheets, an intermediate steel sheet is sometimes welded insufficiently. However, when the insert member **11** is thus buried, the occurrence of an unwelded portion can be prevented, and reliability of a welded joint portion can be enhanced.

1. A member joining method comprising the steps of:
forming an opening in an intermediate member composed of one part or at least two superposed parts;
embedding an insert member formed of metal in the opening;
placing a skin member formed of metal on an outer surface of the intermediate member such that the intermediate member is held on an inner side of the skin member; and
joining the skin member to the insert member.

2. The member joining method according to claim 1, wherein the insert member is formed by an offcut of the skin member.

3. A member joining structure comprising:
an intermediate member composed of one part or at least two superposed parts and having an opening;
a skin member formed of metal and disposed on an outer surface of the intermediate member such that the intermediate member is held on an inner side of the skin member; and
an insert member formed of metal and embedded in the opening.

4. The member joining structure according to claim 3, wherein the insert member is formed by an offcut of the skin member.

* * * * *