



US 20040246299A1

(19) **United States**

(12) **Patent Application Publication** (10) **Pub. No.: US 2004/0246299 A1**

Silverbrook

(43) **Pub. Date:**

Dec. 9, 2004

(54) **MODULAR PRINthead ASSEMBLY WITH THERMAL EXPANSION COMPENSATION**

(30) **Foreign Application Priority Data**

Mar. 9, 2000 (AU)..... PQ611

(75) **Inventor: Kia Silverbrook, Balmain (AU)**

Publication Classification

(51) **Int. Cl.⁷** **B41J 2/015**

(52) **U.S. Cl.** **347/42**

Correspondence Address:
SILVERBROOK RESEARCH PTY LTD
393 DARLING STREET
BALMAIN 2041 (AU)

(57) **ABSTRACT**

A printhead assembly with an elongate support member and two or more printhead modules detachably mounted in series along the support member, the support member having a structural component for strengthening the member, and a mounting component for mounting the printhead modules; wherein,

the mounting component is connected to the structural component to allow relative thermal expansion.

By allowing the structural component of the support to thermally expand relative to the mounting component, the structural components can be strong, inexpensive metal despite the co-efficient of thermal expansion (CTE). Only the mounting component need approximate the CTE of the printhead chips to maintain a suitable alignment of the modules.

(73) **Assignee: Silverbrook Research Pty Ltd.**

(21) **Appl. No.: 10/882,764**

(22) **Filed: Jul. 2, 2004**

Related U.S. Application Data

(63) Continuation of application No. 10/129,437, filed on May 6, 2002, now Pat. No. 6,793,323, filed as 371 of international application No. PCT/AU01/00260, filed on Mar. 9, 2001.

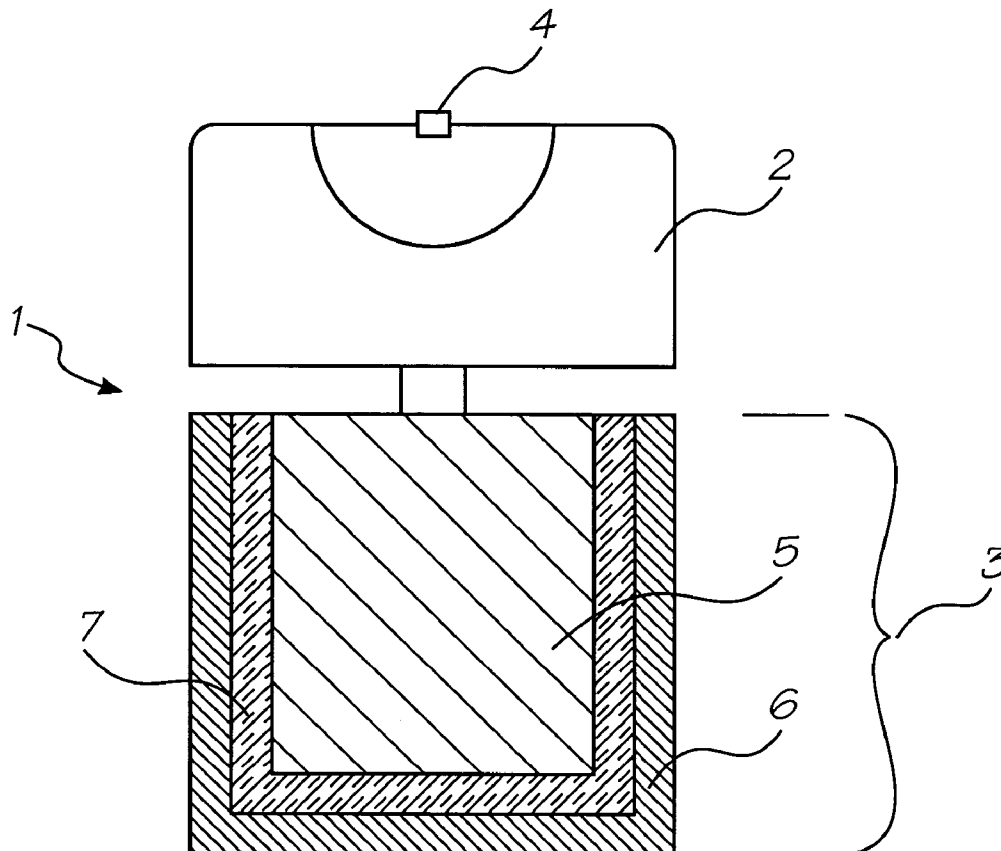

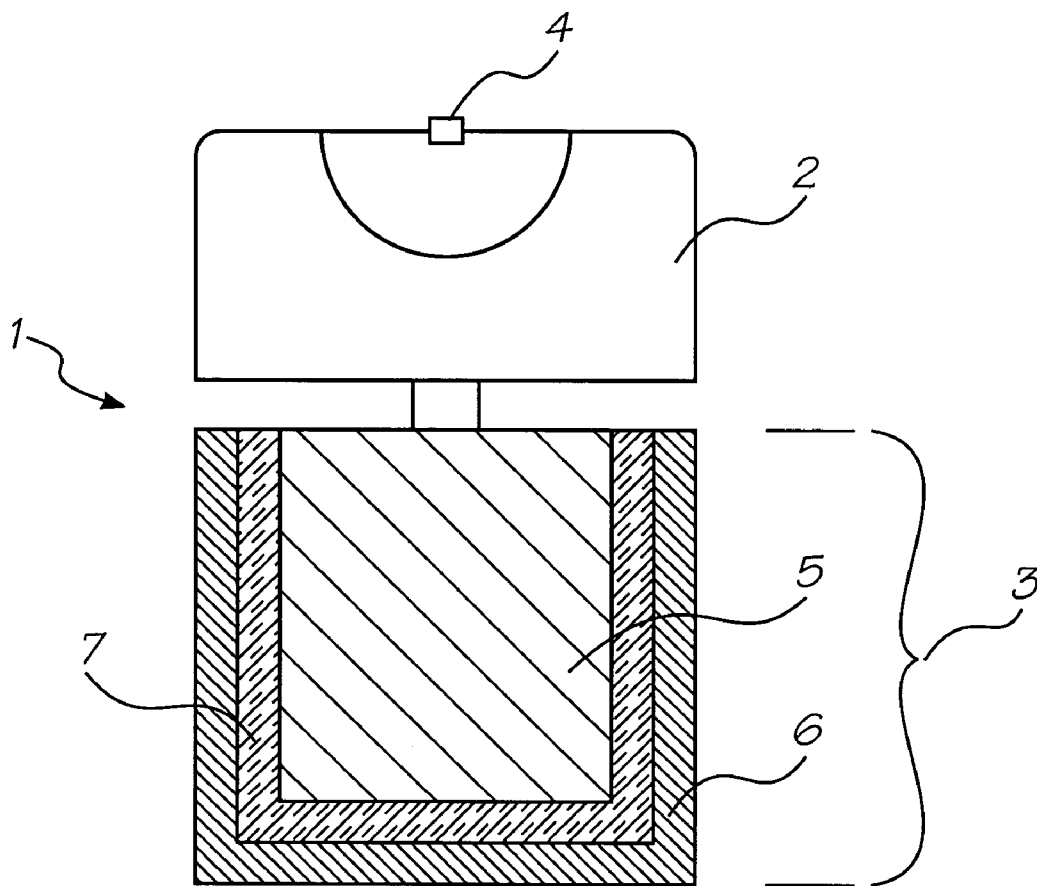

FIG. 1

MODULAR PRINthead ASSEMBLY WITH THERMAL EXPANSION COMPENSATION

[0001] This Application is a Continuation of U.S. Ser. No. 10/129,437 filed May 6, 2002.

CO-PENDING APPLICATIONS

[0002] Various methods, systems and apparatus relating to the present invention are disclosed in the following co-pending applications filed by the applicant or assignee of the present invention on 24 May 2000:

PCT/AU00/00578	PCT/AU00/00579	PCT/AU00/00581	PCT/AU00/00580
PCT/AU00/00582	PCT/AU00/00587	PCT/AU00/00588	PCT/AU00/00589
PCT/AU00/00583	PCT/AU00/00593	PCT/AU00/00590	PCT/AU00/00591
PCT/AU00/00592	PCT/AU00/00584	PCT/AU00/00585	PCT/AU00/00586
PCT/AU00/00594	PCT/AU00/00595	PCT/AU00/00596	PCT/AU00/00597
PCT/AU00/00598	PCT/AU00/00516	PCT/AU00/00517	PCT/AU00/00511

[0003] Various methods, systems and apparatus relating to the present invention are disclosed in the following co-pending application, PCT/AU00/01445, filed by the applicant or assignee of the present invention on 27 Nov. 2000. The disclosures of these co-pending applications are incorporated herein by cross-reference. Also incorporated by cross-reference are the disclosures of two co-filed PCT applications, PCT/AU01/00261 and PCT/AU01/00259 (deriving priority from Australian Provisional Patent Application No. PQ6110 and PQ6158). Further incorporated are the disclosures of two co-pending PCT applications filed 6 Mar. 2001, application numbers PCT/AU01/00238 and PCT/AU01/00239, which derive their priority from Australian Provisional Patent Application nos. PQ6059 and PQ6058.

FIELD OF THE INVENTION

[0004] The present invention relates to printers, and in particular to inkjet printers.

BACKGROUND OF THE INVENTION

[0005] Recently, inkjet printers have been developed which use printheads manufactured by micro-electro mechanical systems (MEMS) techniques. Such printheads have arrays of microscopic ink ejector nozzles formed in a silicon chip using MEMS manufacturing techniques. The invention will be described with particular reference to silicon printhead chips for digital inkjet printers wherein the nozzles, chambers and actuators of the chip are formed using MEMS techniques. However, it will be appreciated that this is in no way restrictive and the invention may also be used in many other applications.

[0006] Silicon printhead chips are well suited for use in pagewidth printers having stationary printheads. These printhead chips extend the width of a page instead of traversing back and forth across the page, thereby increasing printing speeds. The probability of a production defect in an eight inch long chip is much higher than a one inch chip. The high defect rate translates into relatively high production and operating costs.

[0007] To reduce the production and operating costs of pagewidth printers, the printhead may be made up of a series of separate printhead modules mounted adjacent one another, each module having its own printhead chip. To ensure that there are no gaps or overlaps in the printing produced by adjacent printhead modules it is necessary to accurately align the modules after they have been mounted to a support beam. Once aligned, the printing from each module precisely abuts the printing from adjacent modules.

[0008] Unfortunately, the alignment of the printhead modules at ambient temperature will change when the support beam expands as it heats up to the temperature it maintains during operation.

SUMMARY OF THE INVENTION

[0009] Accordingly, the present invention provides a printhead assembly for an inkjet printer, the assembly comprising:

[0010] an elongate support member for mounting in an inkjet printer body; and,

[0011] two or more printhead modules detachably mounted in series along the support member, the support member having a structural component for strengthening the member, and a mounting component for mounting the printhead modules; wherein,

[0012] the mounting component is connected to the structural component to allow relative thermal expansion.

[0013] By allowing the structural component of the support to thermally expand relative to the mounting component, the structural components can be strong, inexpensive metal despite the co-efficient of thermal expansion (CTE). Only the mounting component need approximate the CTE of the printhead chips to maintain a suitable alignment of the modules.

[0014] Optionally, each of the printhead modules has an array of inkjet nozzles formed on a monolithic substrate and the coefficient of thermal expansion of the monolithic substrates is similar to that of the mounting component. The mounting component may be connected to the structural component via an elastomeric element that allows relative thermal expansion and contraction.

[0015] Optionally the structural component is a beam with a channel section and the mounting component is a core house within the channel section. The channel may be an aluminium extrusion and the core may have ink supply channels for the printhead modules.

[0016] Optionally the monolithic substrates and the core are predominantly formed from silicon.

[0017] Optionally the printhead assembly is a pagewidth printhead.

[0018] According to an aspect related to the present invention, there is provided a system for aligning two or more printhead modules mounted to a support member in a printer, the support member having a production temperature when the printhead modules are mounted to the support member, and an operating temperature reached during normal operation of the printer, the system including:

[0019] positioning the printhead modules on the support member to misalign with each other by an amount determined by the coefficient of thermal expansion of the support member, the printhead module spacing on the support member and the difference between the production temperature and the operating temperature, such that they align when the support member is at the operating temperature.

[0020] Preferably, the support member is a beam and the printhead modules include MEMS manufactured chips having at least one fiducial on each;

[0021] wherein,

[0022] the fiducials are used to misalign the printhead modules by a distance calculated from:

[0023] i) the difference between the coefficient of thermal expansion of the beam and the printhead chips;

[0024] ii) the spacing of the printhead chips along the beam; and,

[0025] iii) the difference between the production temperature and the operating temperature.

[0026] Conveniently, the beam may have a core of silicon and an outer metal shell. In a further preferred embodiment, the beam is adapted to allow limited relative movement between the silicon core and the metal shell. To achieve this, the beam may include an elastomeric layer interposed between the silicon core and metal shell. In other forms, the outer shell may be formed from laminated layers of at least two different metals.

[0027] It will be appreciated that this system requires the coefficient of thermal expansion of the printhead chips to be greater than or equal to the coefficient of thermal expansion of the beam, otherwise the "gaps" left between the printhead modules as compensation at ambient temperature will not close as the beam reaches the operating temperature.

BRIEF DESCRIPTION OF THE DRAWING

[0028] A preferred embodiment of the invention will now be described, by way of example only, with reference to the accompanying drawing in which:

[0029] FIG. 1 shows a schematic cross section of a printhead assembly according to the present invention.

DETAILED DESCRIPTION OF PREFERRED EMBODIMENTS

[0030] Referring to the figure the printhead assembly 1 has a plurality of printhead modules 2 mounted to a support member 3 in a printer (not shown). The printhead module includes a silicon printhead chip 4 in which the nozzles, chambers, and actuators are manufactured using MEMS

techniques. Each printhead chip 4 has at least 1 fiducial (not shown) for aligning the printheads. Fiducials are reference markings placed on silicon chips and the like so that they may be accurately positioned using a microscope.

[0031] According to one embodiment of the invention, the printheads are aligned while the printer is operational and the assembly is at the printing temperature. If it is not possible to view the fiducial marks while the printer is operating, an alternative system of alignment is to misalign the printhead modules on the support beam 3 such that when the printhead assembly heats up to the operating temperature, the printheads move into alignment. This is easily achieved by adjusting the microscope by the set amount of misalignment required or simply misaligning the printhead modules by the required amount.

[0032] The required amount is calculated using the difference between the coefficients of thermal expansion of the printhead modules and the support beam, the length of each individual printhead module and the difference between ambient temperature and the operating temperature. The printer is designed to operate with acceptable module alignment within a temperature range that will encompass the vast majority of environments in which it expected to work. A typical temperature range may be 0° C. to 40° C. During operation, the operating temperature of the printhead rise a fixed amount above the ambient temperature in which the printer is operating at the time. Say this increase is 50° C., the temperature range in which the alignment of the modules must be within the acceptable limits is 50° C. to 90° C. Therefore, when misaligning the modules during production of the printhead, the production temperature should be carefully maintained at 20° C. to ensure that the alignment is within acceptable limits for the entire range of predetermined ambient temperatures (i.e. 0° C. to 40° C.).

[0033] To minimize the difference in coefficient of thermal expansion between the printhead modules and the support beam 3, the support beam has a silicon core 5 mounted within a metal channel 6. The metal channel 6 provides a strong cost effective structure for mounting within a printer while the silicon core provides the mounting points for the printhead modules and also helps to reduce the coefficient of thermal expansion of the support beam 3 as a whole. To further isolate the silicon core from the high coefficient of thermal expansion in the metal channel 6 an elastomeric layer 7 is positioned between the core 5 and the channel 6. The elastomeric layer 7 allows limited movement between the metal channel 6 and the silicon core 5.

[0034] The invention has been described with reference to specific embodiments. The ordinary worker in this field will readily recognise that the invention may be embodied in many other forms.

We claim:

1. A printhead assembly for an inkjet printer, the assembly comprising:

an elongate support member for mounting in an inkjet printer body; and,

two or more printhead modules detachably mounted in series along the support member, the support member having a structural component for strengthening the member, and a mounting component for mounting the printhead modules; wherein,

the mounting component is connected to the structural component to allow relative thermal expansion.

2. A printhead assembly according to claim 1 wherein each of the printhead modules has an array of inkjet nozzles formed on a monolithic substrate and the coefficient of thermal expansion of the monolithic substrates is similar to that of the mounting component.

3. A printhead assembly according to claim 2 wherein the mounting component is connected to the structural component via an elastomeric element that allows relative thermal expansion and contraction.

4. A printhead assembly according to claim 1 wherein the structural component is a beam with a channel section and the mounting component is a core house within the channel section.

5. A printhead assembly according to claim 4 wherein the channel is an aluminium extrusion and the core has ink supply channels for the printhead modules.

6. A printhead assembly according to claim 5 wherein the monolithic substrates and the core are predominantly formed from silicon.

7. A printhead assembly according to claim 1 wherein the printhead assembly is a pagewidth printer.

* * * * *