



INTERNATIONAL APPLICATION PUBLISHED UNDER THE PATENT COOPERATION TREATY (PCT)

<p>(51) International Patent Classification⁴ : F42B 37/00</p>	<p>A1</p>	<p>(11) International Publication Number: WO 86/ 01586 (43) International Publication Date: 13 March 1986 (13.03.86)</p>
<p>(21) International Application Number: PCT/US85/01225 (22) International Filing Date: 27 June 1985 (27.06.85) (31) Priority Application Number: 643,189 (32) Priority Date: 22 August 1984 (22.08.84) (33) Priority Country: US</p> <p>(71) Applicant: HARSCO CORPORATION [US/US]; 350 Poplar Church Road, P.O. Box 8888, Camp Hill, PA 17011-8888 (US). (72) Inventors: JOHNSON, Bruce, S. ; R. D. 2, Dallastown, PA 17313 (US). BORST, Paul ; R.D. 1, Box 191, Dallastown, PA 17313 (US). (74) Agents: KONDRACKI, Edward, J. et al.; Kerkam, Stowell, Kondracki & Clarke, 1235 Jefferson Davis Highway #411, P.O. Box 2968, Arlington, VA 22202 (US).</p>		<p>(81) Designated States: BR, DE (European patent), FR (European patent), GB (European patent).</p> <p>Published <i>With international search report.</i> <i>With amended claims.</i></p>

(54) Title: BATTLEFIELD MAGAZINE

(57) Abstract

A battlefield magazine includes a base (14) and a cover (12) which may be used to realize a projectile storage container to protect projectiles (16) against harsh environment conditions and to seal projectiles against contamination from nuclear, biological, and chemical agents. Each of the projectiles within the projectile storage container is individually sealed by a resilient seal (84) compressed between the cover and the base. When access to the projectiles for usage is required, the cover may be removed from the base and replaced with an alternative projectile front protecting device (90) used to lock the front of the projectiles. The projectile locking front (90) together with the base form a projectile storage rack (Fig. 14) used to secure the projectiles, but also allowing their removal for loading into weapons.

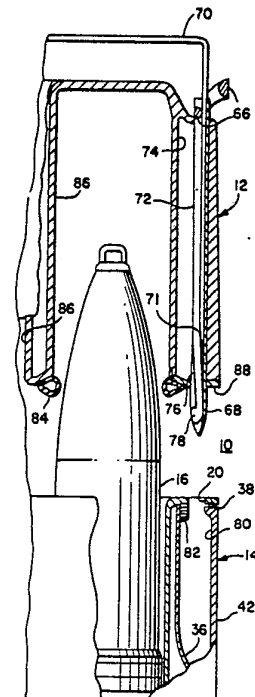

FOR THE PURPOSES OF INFORMATION ONLY

Codes used to identify States party to the PCT on the front pages of pamphlets publishing international applications under the PCT.

AT	Austria	GA	Gabon	MR	Mauritania
AU	Australia	GB	United Kingdom	MW	Malawi
BB	Barbados	HU	Hungary	NL	Netherlands
BE	Belgium	IT	Italy	NO	Norway
BG	Bulgaria	JP	Japan	RO	Romania
BR	Brazil	KP	Democratic People's Republic of Korea	SD	Sudan
CF	Central African Republic	KR	Republic of Korea	SE	Sweden
CG	Congo	LI	Liechtenstein	SN	Senegal
CH	Switzerland	LK	Sri Lanka	SU	Soviet Union
CM	Cameroon	LU	Luxembourg	TD	Chad
DE	Germany, Federal Republic of	MC	Monaco	TG	Togo
DK	Denmark	MG	Madagascar	US	United States of America
FI	Finland	ML	Mali		
FR	France				

- 1 -

BATTLEFIELD MAGAZINE

Background of the Invention

The present invention relates to magazines for carrying and/or storing projectiles.

5 The modern war is often a war of logistics where the winner is determined by the ability to efficiently transport men and material. Accordingly, it is essential to optimize the conveyance of ammunition such as projectiles and shells.

10 For simplicity, "projectiles" as used herein shall be considered to include shells, missiles, torpedoes, bombs, and more generally ammunition.

15 The storage or transportation of projectiles generally requires a balancing between two conflicting considerations. On the one hand, the projectiles should be stored such that it is easy to remove them from their storage mechanism as required for usage of the projectile. On the other hand, the projectiles must be stored such that they are secure in their storage arrangement and will not be jarred loose by nearby explosions or while being transported along a bumpy road. Generally, the more secure a projectile is from accidental dislodgement, 20 the more time-consuming it is to remove the projectile from its storage facility.

25 One common method for transportation and storage of projectiles is by use of a wooden pallet. The pallet is normally configured in two rows of four projectiles. The wooden pallet consists of upper and lower wood laminates held together with steel banding. The bases of the projectiles rest on the lower wood laminate board and the nose protrudes 30

- 2 -

through holes drilled in the top wood laminate board.

The use of wooden pallets is subject to numerous disadvantages. For one thing, the steel banding must be cut or otherwise removed to allow access to all of the projectiles, this in turn necessitating the rebanding of the wooden pallet if the projectiles are to be resecured. Further, the pallet does not protect the projectiles from incidental mechanical damage or from a contaminated environment (storage under high humidity or other harsh conditions or nuclear, biological, or chemical agents). Accordingly, the projectiles require periodic maintenance at considerable expense or likewise expensive decontamination where enemy action has resulted in nuclear, biological, or chemical agents contaminating the outside of the projectiles. In order to maintain or decontaminate the projectiles, the pallet must be broken apart. The projectiles must then be treated to protect them from environmental deterioration and/or to decontaminate them. The projectiles must then be replaced upon the pallet and the upper and lower boards of the pallet must be rebanded together. A further disadvantage of the wooden pallet method is that the projectiles must be removed from the pallets in order to allow them to be readied for usage by placement within an ammunition resupply vehicle such as that disclosed in the U.S. Patent No. 4,236,441 entitled "Field Artillery Ammunition Support Vehicle" issued on December 2, 1980 to John Turner, Richard A. Koster, and Seymour Bassman, and assigned to the assignee of the present application.

- 3 -

Some of the prior art problems with storage and transportation of projectiles have been overcome by the Projectile Lock Assembly disclosed in U.S. Patent No. 4,344,528, issued August 17, 1982 to
5 Ayyala Perisastry, Richard A. Vishe, and Peter J. Hoet. The projectile lock assembly disclosed in that patent, which is assigned to the assignee of the present invention, uses a rack having a plurality of parallel cylindrical tubes. A number
10 of locking assemblies are mounted along each of the tubes and used for individually locking projectiles within the associated tube.

Although the projectile lock assembly of the Perisastry et al patent is extremely useful in
15 providing a storage rack for projectiles, its structure is sufficiently complex as to make it most practical under conditions where projectiles must be separately removed from a storage rack. That is, it is quite useful in an ammunition resupply vehicle
20 where projectiles must be normally secured during the vehicle's movement and selectively removed from projectile storage zones as necessary for conveyance to a self propelled howitzer or other weapon. However, the expense and complexities of the locking
25 structure generally would preclude its use for transportation of projectiles except where individual projectile access is required (i.e., at or near the battlefront where projectiles are fused and/or loaded into weapons).

30 As will be readily appreciated, the transfer of projectiles from a wooden pallet to the projectile rack and lock assembly as disclosed in the Perisastry et al patent adds a time consuming step to the overall process of most efficiently
35 getting projectiles from the factories and/or long

- 4 -

term storage depots to the racks from which the projectiles may be stored and conveyed under battlefield conditions.

Objects and Summary of the Invention

5 Accordingly, it is a primary object of the present invention to provide a new and improved battlefield magazine.

 A more specific object of the present invention is to provide a battlefield magazine which
10 may be used for projectile storage and conveyance under front line conditions as well as long term storage.

 A further object of the present invention is to provide a battlefield magazine which may realize
15 a projectile locking function under battlefield conditions as necessary, but which need not include the projectile locking feature when being used in long term storage or other conditions where projectile locking is not necessary or economically
20 advisable.

 Yet another object of the present invention is to provide a battlefield magazine which will protect projectiles from deterioration under harsh environmental conditions such as high humidity and
25 which will protect projectiles from contamination due to enemy action by way of nuclear, chemical, and biological agents.

 A still further object of the present invention is to provide a battlefield magazine which
30 is relatively light in weight and simple in construction.

 Yet another object of the present invention is to provide a battlefield magazine which is easy
35 to operate for securing and releasing projectiles as desired.

- 5 -

The above and other objects of the present invention which will become apparent as the description proceeds are realized by an apparatus comprising a projectile locking front including:

5 a body having a front and a back; a plurality of projectile front storage zones in the body and extending from the back to the front, each of the front storage zones having an open back to allow projectiles to extend outwardly therefrom and an

10 open front to allow projectiles to extend outwardly therefrom; locking means mounted to the body and selectively operable to secure projectiles against movement out the front of the front storage zones and selectively operable to allow projectile removal

15 out of the front of the front storage zones; and base securing means on the body operable for removably securing a base to the back of the body, the base having a plurality of projectile back storage zones associated on a one-to-one basis with

20 the front storage zones and operable to hold the backs of projectiles which have their noses extending into the projectile front storage zones. Preferably, each of the front storage zones is within a corresponding front storage tube of

25 circular cross-section. The locking means includes a securing portion for each of the front storage zones, each securing portion selectively operable to prevent a projectile from moving out of one of the front storage zones. The invention further

30 comprises a base for holding back portions of a plurality of projectiles and including: a back; a front parallel to the back of said base and having a plurality of projectile openings therein; four sides extending from the back of the base to the front of

35 the base; and a plurality of separate projectile

- 6 -

back storage compartments between the front of the base and the back of the base, the back storage compartments associated on a one-to-one basis with the projectile openings; and wherein the base is

5 removably secured to the locking front by the base securing means. Each of the back storage compartments has a length and transverse dimension to be operable to hold a projectile with at least one-half of the ogive of the projectile extending

10 out from the front of the base. The base further comprises securing means operable for removably securing a projectile front protecting device to the front of the base; and wherein the base is operable to secure alternate projectile front protecting

15 devices to the front of the base, one of the front protecting devices being a cover which encloses at least the front one-half of ogives of projectiles extending out of the back storage zones, and wherein movement of all of the cover is necessary to

20 allow removal of projectiles from the back storage zones; the other of the front protecting devices being the projectile locking front. The base and the cover are together operable to compress at least one resilient seal disposed therebetween and to

25 protect a plurality of projectiles against nuclear, biological and chemical agents. Each of the back storage zones is isolated from the other back storage zones. The base includes a plastic outer molding, a plastic inner molding, and a metal insert

30 frame in between the plastic outer molding and the plastic inner molding; and wherein the plastic inner molding has a plurality of cylindrical tubes each of which defines one of the back storage zones.

The apparatus of the present invention may

35 alternately be described as comprising a base for

- 7 -

holding back portions of a plurality of projectiles
and including: a back; a front parallel to the back
and having a plurality of projectile openings
therein; four sides extending from the back of the
5 base to the front of the base; a plurality of
separate projectile back storage compartments
between the front of the base and the back of the
base with parallel center lines, the projectile back
storage compartments associated on a one-to-one
10 basis with the projectile openings and each having a
length and transverse dimension to be operable to
hold a projectile with at least one-half of the
ogive of the projectile extending out from the front
of the base; and front securing means operable for
15 removably securing a projectile front protecting
device to the front of the base; and wherein the
base is operable to secure alternate projectile
front protecting devices to the front of the base;
one of the front protecting devices being a cover
20 which encloses at least the front one-half of the
ogives of projectiles extending out from the back
storage compartments, the base and the cover are
together operable to compress at least one resilient
seal disposed therebetween and to protect a
25 plurality of projectiles against nuclear,
biological, and chemical agents, and movement of all
of the cover is necessary to allow removal of
projectiles from the back storage compartments; the
other of the front protecting devices being a
30 projectile locking front having locking means
selectively operable to secure projectiles against
movement out of the back storage compartments and
selectively operable to allow projectile removal
from the back storage compartments with the
35 projectile locking front disposed at the front of

- 8 -

the base. Each of the back storage compartments is isolated from the other back storage compartments. The base includes a plastic outer molding, a plastic inner molding, and a metal insert frame in between
5 the plastic outer molding and the plastic inner molding; and wherein the plastic inner molding has a plurality of circular cross-section tubes each of which defines one of the back storage compartments. The apparatus further comprises a cover operable to
10 enclose at least one-half of the ogives of projectiles extending out from the base and including: a cover body having a closed off front, a back, four sides extending from the front to the back; a plurality of projectile front storage zones
15 disposed in the cover body and extending from the back of the cover body to the front of the cover body; and back securing means operable with the front securing means for removably securing the cover to the base with the plurality of back storage
20 compartments in the base corresponding on a one-to-one basis with the projectile front storage zones such that each front storage zone may hold the front of a projectile having its back extending into the corresponding back storage compartment. The
25 apparatus further comprises a plurality of resilient seals disposed for compression between the cover and the base and corresponding on a one-to-one basis with the projectile openings; and wherein each back storage compartment and associated front storage
30 zone together defines a projectile chamber isolated from other projectile chambers. The cover further includes at least one control on the cover body operable for activating and deactivating the
securing means. The projectile locking front
35 includes: a body having a front and a back; a

5 plurality of projectile front storage zones in the
body and extending from the back to the front, each
of the front storage zones having an open back to
allow projectiles to extend outwardly therefrom and
an open front to allow projectiles to extend
10 outwardly therefrom; locking means mounted to the
body of the locking front and selectively operable
to secure projectiles against movement out the front
of the front storage zones and selectively operable
15 to allow projectile removal out of the front of the
projectile front storage zones; and base securing
means on the body operable with the front securing
means for removably securing the base to the back of
the body of the locking front such that the back
20 storage compartments correspond on a one-to-one
basis with the front storage zones. The locking
means includes a securing portion for each of the
front storage zones, each securing portion
selectively operable to prevent a projectile from
moving out of one of the front storage zones. Each
of the front storage zones is within a corresponding
cylindrical front storage tube.

The apparatus of the present invention may
alternately be described as a cover operable to
25 enclose at least one-half of the ogives of
projectiles extending out from a base and including:
a cover body having a closed off front, a back, four
sides extending from the front to the back; a
plurality of projectile front storage zones disposed
30 in the cover body and extending from the back to the
front; back securing means operable for removably
securing the cover to the base with a plurality of
projectile back storage compartments in the base
corresponding on a one-to-one basis with the front
35 storage zones such that each front storage zone may

- 10 -

hold the front of a projectile having its back
extending into the corresponding back storage
compartment; and at least one control on the cover
body operable for activating and deactivating the
5 back securing means; and wherein the cover and base
are together operable to compress at least one
resilient seal disposed therebetween and to protect
a plurality of projectiles against nuclear,
biological, and chemical agents. The apparatus may
10 further comprise a base removably secured to the
cover. The base is operable to secure alternate
projectile front protecting devices to the front of
the base; one of the front protecting devices being
the cover; the other of the front protecting devices
15 being the projectile locking front.

The method for storing projectiles and
making them accessible for usage comprises the steps
of: placing a plurality of projectiles in a
projectile container having a base and a cover as
20 described above, the projectiles being inaccessible
with the cover on the base; and removing the cover
when the projectiles are to be made ready for
access; and securing a projectile locking front as
described above to the base, the projectile locking
25 front allowing access and removal of the projectiles
while it is secured to the base.

Brief Description of The Drawings

The above and other other features of the
present invention will be more readily understood
30 when the following detailed description is
considered in conjunction with the accompanying
drawings wherein like characters represent like
parts through out the several views and in which:

FIG. 1 shows a perspective exploded view of a base and a cover of the present battlefield magazine.

5 FIG. 2 shows two battlefield magazines attached to a sling for ease of handling.

FIG. 3 shows a perspective view of the base of the present battlefield magazine with projectiles disposed therein.

10 FIG. 4 shows an exploded perspective view of parts of the base of the present battlefield magazine.

FIG. 5 shows a top view of the base of the present invention.

FIG. 6 shows a side of the base.

15 FIG. 7 shows a cross-section view taken along lines 7-7 of FIG. 6.

FIG. 8 shows a cross-section view taken along lines 8-8 of FIG. 7.

20 FIG. 9 shows a bottom view of the inner shell used for the base of the present invention.

FIG. 10 shows an exploded view of parts of the cover of the present battlefield magazine.

25 FIG. 11 shows a partial cross-section side view of the cover and the base of the battlefield magazine prior to their attachment together.

FIG. 12 shows a partial cross-section side view of the cover and base together.

30 FIG. 13 shows a perspective view of the base and a projectile locking front of the present battlefield magazine prior to its attachment to the base.

FIG. 14 shows the base and projectile locking front in assembled condition and about to be attached to two other base/locking unit assemblies.

- 12 -

FIG. 15 shows a perspective view of a locking arrangement which may be used with the present invention.

5 FIG. 16 shows back securing arrangement which may be used with the present invention.

Detailed Description of The Preferred Embodiments

Turning now to the perspective exploded view of FIG. 1, a projectile storage container 10 according to the present invention is shown. In particular, the projectile storage container 10 comprises a cover 12 and a base 14. Considering also the perspective view of FIG. 2, showing two of the projectile storage containers 10 strapped to a sling and FIG. 3, showing the base 14 with a plurality of projectiles 16 having their backs or tail sections disposed within the base 14, the basic purpose of the projectile storage container 10 will be readily understood. In particular, projectiles such as 16 may be loaded into the base 14 and the cover 12 may be attached to the front of the base 14 for conveying and/or long term storage of the projectiles 16 in the manner described in detail below. The base 14 is preferably constructed such that at least one-half of the ogives (the tapered front portions) of the projectiles extend forwardly out of the base 14.

Considering now FIG. 4 in conjunction with FIG. 1, the structure of the base 14 will be discussed in detail. FIG. 4 shows an exploded perspective view of various components of the base 14 of the present invention. The base 14 includes a two-by-five array of identically sized circular projectile openings 18 and four front securing holes 20. (For ease of illustration, the figures do not have labels for each of openings 18, holes 20, or

- 13 -

other parts which include a plurality of like-constructed parts.) The openings 18 and holes 20 are disposed in a front plate 22 which is part of an inner plastic molding 24 also including a two-by-five array of projectile storage tubes 26. As best shown in the back (i.e., bottom view relative to the position of FIG. 4) view of FIG. 9, the plastic inner molding 24 further includes a series of webs 28 extending between the adjacent tubes 26.

Although the tubes 26 are open at the projectile openings 18 at their fronts, the tubes 26 are closed at their backs 30. A number of channels 32 are disposed in numerous of the backs 30. There is slightly more distance between the end tubes 26E and the next two end tubes 26N in order to accommodate a metallic cross brace 34 shown broken away and in cross section in FIG. 9. A similar cross brace 34 would also be disposed between the left end tubes 26E and the tubes 26N next to the left end tubes, this having been left off the left side for simplicity.

It should be noted that the front plate 22 is considered to be at the "front" of the base 14 in that it is closest to the nose or tip of the projectiles 16 (refer back momentarily to FIG. 3). Likewise, the back 30 of the tubes 26 is considered to be "back" because it is towards the back of the projectile 16. As used throughout this application, "front" and "back" shall be defined with reference to the tip and tail respectively of the projectiles. Thus, in FIG. 3, the base 14 is sitting upon its back.

Turning now to FIG. 4, it will be noted that the cross braces 34, one of which was partially shown in cross-section in FIG. 9, are part of a

- 14 -

metal frame 36 which also includes a front peripheral rectangular reinforcing member 38 and a back peripheral reinforcing member 40. Each of the reinforcing members 38 and 40 connect to identically constructed reinforcing structures including the cross braces 34 extending between securing channel portions 42 connected by back pieces 44. The back reinforcing rectangular member 40 may be welded to the back pieces 44.

Each of the identically constructed securing channel portions 42 includes an opening 46 and slide portions 48 with projecting portions 50 disposed therebetween.

As shown in FIG. 4, the base 14 further includes an outer plastic molding 52 having slots 54 disposed therein, both sides of the slots 54 including channels 56 into which the slide portions 58 of metal frame 36 may be disposed. The front (i.e., top in FIG. 4) of the outer molding 52 includes a peripherally extending channel 58 into which the peripherally extending front reinforcing member 38 may be disposed. The back 60 (bottom in FIG. 4) of the outer molding 52 may include two slots 62 for accommodating the tines of a fork slift. Additionally, two slots 64 may be included for use with particular types of slings wherein a cable is extended underneath the object to be lifted.

Considering now FIGS. 5-9 in conjunction with FIG. 4, the steps of construction for the base 14 of the present invention will be discussed. FIG. 5 shows a front view of the base 14 of the present invention, whereas FIG. 6 shows a side view of the base. FIG. 7 shows a partial cross-section view taken along lines 7-7 of FIG. 5. FIG. 8 shows a

- 15 -

cross-section view taken along lines 8-8 of FIG. 7. FIG. 9 shows a back view of the plastic inner molding 24 with one of the cross braces 34 of metallic frame 36 shown in cross-section and broken away. The metallic frame 36 is slid into the outer molding 52 with slide portions 48 seating within the slot channels 56 of the slots 54. At the same time, the front peripheral reinforcing rectangular member 38 will seat within the peripheral channel 58 of the outer molding 52. The projecting portions 50 help center the securing channel portions 42 within the slots 54. There may be two projecting portions 50 (as shown in FIG. 4) for each securing channel portion 52 or, alternately as shown in FIG. 6, each securing channel portion 42 may include a single projecting portion 50.

The inner plastic molding 24 may then be slid into the outer plastic molding 52 with the metal frame 36 disposed therebetween. In particular, the cross braces 34 are slid between the end tubes 26E (see especially FIG. 9) and the next two end tubes 36N in the manner shown for the right cross brace 34 in FIG. 9. The front plate 22 of the inner molding 24 will then cover the channel 58 in which the peripheral metal reinforcing member 38 will be trapped. The back pieces 44 may include upwardly turned flanges at their edges (not shown) which seat within the channels 32 (see especially FIG. 9) on the back of the inner molding 24. The inner plastic molding 24 may then be plastic welded to the outer plastic molding 52 as, for example, around the edges of the front plate 22. Additionally, if desired, a part of the inner molding 24 (not shown) could extend through a hole

- 16 -

in the back 60 to provide an additional point for plastic welding.

5 Considering now FIGS. 10-12 in conjunction with FIG. 1, the details of construction of the cover 12 of the present invention will be discussed in detail. FIG. 10 shows a perspective view with some parts removed from the cover 12, whereas FIGS. 11 and 12 show cross-section sequence partial views illustrating how the cover 12 is attached to the base 14 with a projectile 16 disposed therebetween.

10 The cover 12 includes a plurality of lift bar weldments 66 which are attached to the lock bars 72 and trapped within a notch 67 in the channel weldments 68. Instead of including a lift bar weldment such as 66, the lock bar 72 might simply have a locking transverse portion 66' (as per left side of FIG. 10 only). In either case, the lock bar 72 would be secured against sliding movement relative to the channel weldment 68. A control strap 70 includes slanted camming surfaces 71 as best seen in FIG. 10.

15 As shown in FIG. 11, the parts 66, 68, 70, and 72 are mounted within a channel 74 in the side of the cover 12. Together, these parts may be considered as a back securing means in that they secure a back (i.e., the base 14) to the cover 12. The lock bar 72 is slanted outwardly at 76 down to a locking part 78. When the control strap 70 is in the position shown in FIG. 11, the cover 12 may be inserted over the base 14 with the part 78 and tip of channel weldment 68 extending through the hole 20 into a securing chamber 80 within the securing channel portion 42 of the metal frame 36. A metallic block or stop 82 is also disposed within the chamber 80.

25

30

35

- 17 -

When the cover 12 is brought into contact with the base 14, a plurality of resilient circular seals 84 will be compressed therebetween. Each of the resilient seals 84 corresponds on a one-to-one basis with a projectile front storage zone defined by cylindrical front storage tubes 86 which are connected by webbing as shown in FIG. 10. FIG. 11 shows only a single annular seal 84 which is disposed upon a back panel 88. For ease of illustration, the back panel 88 and the seals 84 are not shown in the perspective view of FIG. 10. As will be readily appreciated, there is one projectile front storage cylindrical tube 86 for each of the projectiles 16 which may have their backs or tail sections disposed within an associated projectile back storage zone or compartment defined by the cylindrical tubes 26 (refer back momentarily to FIG. 4).

When the cover 12 has been placed into contact with the base 14 such that each of the seals 84 is compressed therebetween, the cover 12 may be secured to the base 14 by pushing the control straps 70 downward. This in turn moves the camming surface 71 down and pushes out on the lower slanted portion 76 of the lock bar 72 such that the lock part 78 is moved into solid contact with the securing block 82 in the securing chamber 80 of the base 42. This is the position shown in FIG. 12. Note that lifting the projectile storage container 10 formed by the cover 12 and the base 14 by way of the lifting bar weldments 66 will be transmitted directly to the securing block 82, thus maintaining the strong connection between the cover 12 and base 14.

An alternate (not shown) to the arrangement of camming surface 71 of strap 70 and slanted

- 18 -

portion 76 of lock bar 72 could use a straight lock bar and strap with push-out blocks in place of cam surfaces 71, the push-out blocks increasing the separation between the lower ends of part 72 and channel 68 to lock the cover in place.

The resilient seals 84 are useful to avoid long term deterioration of the projectile 16 as may be caused by harsh environmental conditions such as high humidity. By separately sealing each of the projectiles 16 (an annular seal 84 is included for each of the projectile front storage tubes 86) moisture which might accidentally have been trapped within one of the projectile storage zones defined by the front projectile storage tubes 86 together with the corresponding back projectile storage tube 26 would only be able to damage the particular projectile having the moisture trapped in its chamber. That is, each projectile has a separate chamber isolated from each other projectile chamber.

The resilient seals 84 are not only very useful for protecting the projectile 16 against deterioration under long term storage conditions, but also serve to protect the projectiles against nuclear, biological, and chemical agents. That is, the projectiles 16 would be sealed against contamination due to chemicals, biological agents, or radioactive fall-out contacting their surfaces. Because the outside of the projectile storage container 10 comprised of cover 12 and base 14 is relatively smooth, it may be decontaminated in relatively simple fashion, instead of having to decontaminate each projectile individually.

The resilient seals 84 are additionally useful in that they press against the projectile 16

- 19 -

(as best shown in FIG. 12) to maintain the projectile 16 against slight movements within the projectile storage container 10.

5 The parts of cover 12 and base 14 except for metallic parts 36, 66, 68, 70, 72, and 82 may be made of high density polyethylene, although other plastics might be used.

10 The securing chamber 80 and securing block 82 function as a front securing means on the base 14 in that they allow the base 14 to have a front piece removably attached thereto.

15 Cover 12 can be removed from base 14 by pulling the control straps 70 upwardly to their position of FIG. 11. Fist-accommodating recesses 77 (FIG. 1) allow one to pull the control straps 70 up and cause lock portion 78 to clear block 82 (FIGS. 11 and 12).

20 Turning now to FIGS. 13, 14, 15, and 16, the projectile locking front 90 of the present invention will be discussed in detail. As illustrated by the arrows in FIG. 13, the projectile locking front 90 may be alternately placed over the base 14 when the cover 12 has been removed therefrom. Together, the base 14 and projectile locking front 90 comprise a
25 projectile locking rack which, as shown in FIG. 14 may be stacked one on top of the another with access to the front or nose of the projectiles 16.

30 The projectile locking front 90 may attach to the base 14 in any of numerous ways. Preferably however, the projectile locking front 90 may include a back securing means operating on the same basic principles as those used by the lock bar 72 (see especially FIGS. 11 and 12) as used with the cover
35 12. One possible arrangement is shown in FIG. 16 which is a simplified detail view showing the back

- 20 -

plate 94 of the projectile locking front 90 having a hole 96 disposed therein through which a channel weldment 98 and locking bar 100 extend. The locking bar 100 includes a transverse bar 102 (similar to 5 66' in FIG. 10) trapped in a notch within the channel weldment 98. Additionally, the transverse bar 102 may extend to a boss or bosses (not shown) extending up from the back plate 94, thereby securing the channel weldment 98 and lock bar 100 to 10 the projectile locking front 90. The lower portion of the lock bar 100 includes a slanted portion 104 and lock part 106 having similar functions to the respective slanted portion 76 and lock part 78 used in FIG. 11 and FIG. 12. A control lever 108 is 15 pivotably mounted at point 110 to the boss or bosses (not shown) extending upwardly from the back plate 94. Adjacent the pivot point 110, the lever 108 includes a cam surface 112. When the control lever 108 lies in its deactivation position generally 20 parallel to back plate 94 (FIGS. 13 and 16), the cam 112 allows the lock bar 100 and channel weldment 98 to be disposed within the securing chamber 80 (refer back to FIGS. 11 and 12). When the control lever 108 is rotated to be generally perpendicular to the 25 back plate 94 (see FIG. 14) this causes cam surface 112 to straighten out the lock bar 100 such that lock bar 100 and channel weldment 98 will have relative positions similar to that of lock bar 72 and channel weldment 68 in FIG. 12. Accordingly, 30 rotating the control lever 108 upwards will lock the projectile locking front 90 to the base 14. The cam 112 could be integral with the control lever 108 or, alternately, could be a separate cam fixed to rotate with the control lever 108. All four levers 108 35 (FIG. 13 and FIG. 14) should be rotated up to lock the front 90 to base 14.

- 21 -

Although a specific construction for the projectile locking mechanisms used with the projectile locking front 90 will be presented herein, the specifics of the locking arrangement are described in detail in U.S. Patent application No.

5 of Bruce S. Johnson filed concurrently herewith, entitled SPIRAL BAND LOCKING MECHANISM, and assigned to the assignee of the present invention. That application, which is hereby
10 incorporated by reference, discloses and claims the specifics for the locking mechanisms illustrated in FIG. 15 of the present application. Of course, the concept of using a relatively inexpensive cover for long term storage and normal transportation of
15 projectiles and replacing the relatively inexpensive cover with a separate locking front using a common base is broadly applicable regardless of the specific projectile locking mechanisms used. For example, the control rod and cam locking arrangement
20 used in the Perisastry et al. 4,344,528 U.S. Patent could be adapted for use with the present invention by shortening the cylindrical tubes, opening the backs of the cylindrical tubes, and modifying the Perisastry et al. structure so as to allow it to be
25 bolted or otherwise secured to the base of the present invention.

The projectile locking front 90 includes a front plate 114, the back plate 94, and two side plates 116 extending therebetween. Additionally, a
30 two-by-five array of cylindrical projectile front storage tubes 118 extend between the front plate 114 and the back plate 94. Each of the cylindrical tubes is open at both of its ends and defines a

- 22 -

projectile front storage zone or compartment therein.

As best shown in the detailed simplified perspective of FIG. 15, the front storage tubes 118 are welded to the back of the front plate 114 and include an arcuate slot 120 in between the lower front part of the tubes 118 and the front plate 114. A securing portion steel band comprising connected parts 122F and 122R is fixed to a pin 124F. The rear steel band portion 122R would likewise be fixed at its back end to a similar pin or mounting point (not shown). Preferably, the rear steel band portion 122R is arranged to extend in spiral fashion around the projectile 16. The front band portion 122F is connected to a spring-loaded release lever or rod controller 126 which may, for example, be spring-biased by its own resilience. The release lever 126 is biased towards the right side (with respect to FIG. 15) of the projectile locking front 90. Accordingly, the release lever 126 normally pulls the steel band portions 122F and 122R into the securing position shown at the bottom of FIG. 15 whereby the steel band portions prevent the projectile 16 from moving out of the front of the projectile locking front 90. In order to allow removal of the projectile 16, the release lever 126 is manually operated by knob 128 to be slid leftwardly and hooked onto a notch 130 which secures the spring biased release rod 126 against rightward movement. The notch 130 is disposed in a piece 132 which is welded or otherwise fixed to the front plate 114. When the release rod 126 is disposed in its far leftward position and locked into the notch 130 as shown for the top release rod 126 in FIG. 15, the steel band portions 122F and 122R will likewise

- 23 -

be moved leftwardly (not shown in the top of FIG. 15) such that a projectile may be moved in or out of the associated projectile storage tube 118.

5 A latching frame assembly 134 includes links 136 pivotably attaching it to a release lever 138. The release lever 138 is in turn mounted to flanges 140 extending out from the front of the projectile locking front 90. The release lever 138 is attached in an overtoggle fashion such that moving it up and
10 down will likewise slide the release frame assembly 138 up and down. The release frame assembly further includes a number of fingers 142 and serrated portions 144. For simplicity of illustration, the steel bands 122F and 122R, spring release rods 126
15 serrated portions 144 and fingers 142 are not shown for each of the projectile storage tubes 118, although it will be readily appreciated that each of these storage tubes 118 has a corresponding one of these parts associated with it. Although FIG. 15
20 only shows the left side release lever 138, it will be readily appreciated that a right side release lever (also 138 in FIG. 13) is preferably used as well.

The operation of the spring release rod 126
25 in conjunction with the release frame assembly 134 is relatively straightforward. In the closed and unlocked position as shown at the bottom of FIG. 15, the spring release rod 126 is held by spring tension such that the steel band 122F and 122R wrap around
30 the ogive of the projectile. The release lever 138 is disposed in its middle position as shown in FIG. 15 such that the release frame assembly 134 disposed so that spring release rod 126 is above the serrated portion 124. This is the normal position of the
35 mechanism and is used to hold the projectiles in the

- 24 -

rack when the vehicle is stopped and preparing to load or unload.

From the position shown at the bottom of FIG. 15, the spring release rod 126 may simply be
5 slid leftwardly and latched to the notch 130 to the position shown at the top of FIG. 15 such that a projectile may be loaded or unloaded from the corresponding projectile storage tube 118.

10 In order to gang lock all of the projectiles within their corresponding projectile front storage tubes 118, the levers 138 are moved downwardly causing the release frame assembly 134 to likewise move to its down most position. This causes the
15 fingers 142 on the release frame assembly 134 to move downwardly and release any of the spring release rods 126 which are being held within the corresponding notches 130. Thus, from the position shown in FIG. 15, the top release rod 126 will be
20 pushed out of the top notch 130 by the top finger 142. The spring bias of the rod 126 will then move it leftwardly against any projectile disposed within that corresponding storage tube 118. Thus, with the release levers 138 in their down-most positions and the release frame assembly likewise in its down
25 position, all of the projectile storage tubes will be closed with the spring-bias of release rods 126 causing the steel bands 122R and 122F to secure the corresponding projectiles. This closed position will generally hold the projectiles in place.
30 However, if the vehicle in which the projectile locking front 90 is disposed is going to be moved rapidly, it is preferable to lock all of the projectiles in place by moving the release levers 138 to their upper most positions such that the
35 release frame assembly 134 is likewise in its

- 25 -

upper most position. In this upper position with the release levers 138 generally vertical, the serrated portions 144 will be moved sufficiently upwardly so as to trap the corresponding spring release rod 126. The release rod 126 may not be moved with the release lever 138 in its upper most position, because attempts to move the release rod 126 upwardly and out of the serrated portion 144 will be blocked by the part 132. Accordingly, each of the projectiles 16 will not only be closed or held in the corresponding projectile storage tube 118 by the spring force of release rod 126, but will additionally be mechanically blocked by the serrated portions 144.

When it is desirable to unlock the projectiles, the release levers 138 may simply be pivoted downward to the neutral position shown in FIG. 15, whereupon the individual release rods 126 may be used to separately open and close each of the projectile storage tubes 118.

It should be noted that the use of a plurality of serrations as with serrated portion 144 allows the projectile locking front 90 to accommodate various sizes of projectiles. Depending upon the particular length and diameter (minor variations in diameter could be accommodated) of the projectiles, the spring release rod 126 would lock the projectiles in place by seating within different of the serrations in serrated portion 144.

The overall use of the present invention is relatively straightforward. Projectiles 16 may be placed within the base 14 (referring back to FIGS. 1-3) and the cover 12 may be attached thereto. The projectiles will be safe from nuclear, chemical, and biological agents and will be protected against

- 26 -

harsh environmental conditions. The projectiles may be transported in the projectile container 10 to a place or vehicle whereat the projectiles will be used. Instead of having to remove the projectiles from the projectile storage container 10, the cover 12 may simply be removed and replaced by the alternate projectile front protecting device 90 as shown in FIG. 13. Once the projectiles are secured within the projectile locking rack 92 made from the assembly of projectile locking front 90 onto base 14, the projectile locking rack 92 may be placed upon similar locking racks as shown in FIG. 14. Mating lugs and channels (not shown) or other techniques may be used for stacking the racks in similar fashion to the stack accommodating features of the Perisastry et al. patent. Referring to FIG. 15, each of the projectile storage compartments comprising the projectile front storage tubes 118 and corresponding projectile back storage compartment defined by tubes 26 (FIG. 4) may be individually opened or closed by use of the spring release rods 126. If necessary to move the vehicle in which the rack 92 is disposed, the release levers 138 may be used to quickly lock all of the projectiles in place.

The parts of the projectile locking front 90 are preferably made of metal, although other materials could also be used.

Although specific details have been disclosed herein, it is to be understood that these are for illustrative purposes only. Various modifications and adaptations will be apparent to those of ordinary skill in the art. Accordingly, the scope of the present invention should be

determined by reference to the claims appended hereto.

- 28 -

What is Claimed is:

1. An apparatus comprising a projectile locking front including:

(a) a body having a front and a back;

5

(b) a plurality of projectile front storage zones in said body and extending from said back to said front, each of said front storage zones having an open back to allow projectiles to extend outwardly therefrom and an open front to allow projectiles to extend outwardly therefrom;

10

(c) locking means mounted to said body and selectively operable to secure projectiles against movement out the front of said storage zones and selectively operable to allow projectile removal out of the front of said front storage zones; and

15

20

(d) base securing means on said body operable for removably securing a base to said back of said body, the base having a plurality of projectile back storage zones associated on a one-to-one basis with said front storage zones and operable to hold the backs of projectiles which have their noses extending into said projectile front storage zones.

25

2. The apparatus of Claim 1 wherein each of said front storage zones is within a corresponding front storage tube.

- 29 -

3. The apparatus of Claim 1 wherein said locking means includes a securing portion for each of said front storage zones, each securing portion selectively operable to prevent a projectile from moving out of one of said front storage zones.

4. The apparatus of Claim 1 further comprising a base for holding back portions of a plurality of projectiles and including:

- a back;
- a front parallel to said back of said base and having a plurality of projectile openings therein;
- four sides extending from said back of said base to said front of said base; and
- a plurality of separate projectile back storage zones between said front of said base and said back of said base, said back storage zones associated on a one-to-one basis with said projectile openings; and

wherein said base is removably secured to said locking front by said base securing means.

5. The apparatus of Claim 4 wherein each of said back storage zones has a length and transverse dimension to be operable to hold a projectile with at least one-half of the ogive of the projectile extending out from said front of said base.

6. The apparatus of Claim 4 wherein said base further comprises securing means operable for removably securing a projectile front protecting device to said front of said base; and

- 30 -

5 wherein said base is operable to secure alternate
projectile front protecting devices to said front of
said base; one of said front protecting devices
being a cover which encloses at least the front
one-half of the ogives of projectiles extending out
10 of said back storage zones, and wherein movement of
all of the cover is necessary to allow removal of
projectiles from said back storage zones; the other
of said front projecting devices being said
projectile locking front.

7. The apparatus of Claim 6 wherein said
base and the cover are together operable to compress
at least one resilient seal disposed therebetween
and to protect a plurality of projectiles against
5 nuclear, biological, and chemical agents.

8. The apparatus of Claim 4 wherein each
of said back storage zones is isolated from the
other back storage zones.

9. The apparatus of Claim 4 wherein said
base includes a plastic outer molding, a plastic
inner molding, and a metal insert frame in between
said plastic outer molding and said plastic inner
5 molding; and wherein said plastic inner molding has
a plurality of tubes each of which defines one of
said back storage zones.

10. An apparatus comprising a base for
holding back portions of a plurality of projectiles
and including:

- (a) a back;
- 5 (b) a front parallel to said back and
having a plurality of projectile openings
therein;

- 31 -

- 10 (c) four sides extending from said back of
said base to said front of said base;
(d) a plurality of separate projectile
back storage compartments between said
front of said base and said back of said
base with parallel center lines, said
projectile back storage compartments
15 associated on a one-to-one basis with said
projectile openings and each having a
length and transverse dimension to be
operable to hold a projectile with at least
one-half of the ogive of the projectile
20 extending out from said front of said base;
and
(e) front securing means operable for
removably securing a projectile front
projecting device to said front of said
25 base; and

wherein said base is operable to secure alternate
projectile front protecting devices to said front of
said base; one of said front protecting devices
being a cover which encloses at least the front
30 one-half of the ogives of projectiles extending out
of said back storage compartments, said base and the
cover are together operable to compress at least one
resilient seal disposed therebetween and to protect
a plurality of projectiles against nuclear,
35 biological, and chemical agents, and wherein
movement of all of the cover is necessary to allow
removal of projectiles from said back storage
compartments; the other of said front protecting
devices being a projectile locking front having
40 locking means selectively operable to secure
projectiles against movement out of said back
storage compartments and selectively operable to
allow projectile removal from said back storage

- 32 -

45 compartments with the projectile locking front
disposed at said front of said base.

11. The apparatus of Claim 10 wherein each
of said back storage compartments is isolated from
the other back storage compartments.

12. The apparatus of Claim 10 wherein said
base includes a plastic outer molding, a plastic
inner molding, and a metal insert frame in between
said plastic outer molding and said plastic inner
5 molding; and wherein said plastic inner molding has
a plurality of tubes each of which defines one of
said back storage compartments.

13. The apparatus of Claim 10 further
comprising a cover operable to enclose at least the
front one-half of ogives of projectiles extending
out from said base and including:

5 a cover body having a closed off front,
a back,
four sides extending from said front to
said back;
10 a plurality of projectile front storage
zones disposed in said cover body and
extending from said back of said cover body
to said front of said cover body; and
securing means operable with said front
15 securing means for removably securing said
cover to said base with said plurality of
back storage compartments in said base
associated on a one-to-one basis with said
projectile front storage zones such that
20 each projectile front storage zone may hold
the front of a projectile having its back

- 33 -

extending into the associated back storage compartment.

14. The apparatus of Claim 13 further comprising a plurality of resilient seals disposed for compression between said cover and said base and associated on a one-to-one basis with said
5 projectile openings; and wherein said each back storage compartment and associated front storage zone together define a projectile chamber isolated from other projectile chambers.

15. The apparatus of Claim 13 wherein said cover further includes:

at least one control on said cover body operable for activating and deactivating
5 said back securing means.

16. The apparatus of Claim 10 further comprising a projectile locking front including:
a body having a front and a back;
5 a plurality of projectile front storage zones in said body and extending from said back to said front, each of said front storage zones having an open back to allow projectiles to extend outwardly therefrom and an open front to allow projectiles to
10 extend outwardly therefrom;
locking means mounted to said body of said locking front and selectively operable to secure projectiles against movement out the front of said front storage zones and
15 selectively operable to allow projectile removal out of the front of said projectile front storage zones; and

- 34 -

20 base securing means on said body operable
with said front securing means for
removably securing said base to said back
of said body of said locking front such
that said back storage compartments
correspond on a one-to-one basis with said
front storage zones.

5 17. The apparatus of Claim 16 wherein said
locking means includes a securing portion for each
of said front storage zones, each securing portion
selectively operable to prevent a projectile from
moving out of one of said front storage zones.

18. The apparatus of Claim 17 wherein each
of said front storage zones is within a
corresponding front storage tube.

19. An apparatus comprising a cover
operable to enclose at least the front one-half of
the ogives of projectiles extending out from a base
and including:

- 5 (a) a cover body having a closed off
front, a back, four sides extending from
said front to said back;
- 10 (b) a plurality of projectile front
storage zones disposed in said cover body
and extending from said back to said
front;
- 15 (c) back securing means operable for
removably securing said cover to the base
with a plurality of projectile back storage
compartments in the base corresponding on a
one-to-one basis with said front storage

- 35 -

20 zones such that each front storage zone may hold the front of a projectile having its back extending into the corresponding back storage compartment; and

(d) at least one control on said cover body operable for activating and deactivating said back securing means; and

25 wherein said cover and the base are together operable to compress at least one resilient seal disposed therebetween and to protect a plurality of projectiles against nuclear, biological, and chemical agents.

20. The apparatus of Claim 19 further comprising a base for holding back portions of a plurality of projectiles and including:

5 a back;

a front parallel to said back of said base and having a plurality of projectile openings therein;

four sides extending from said back of said base to said front of said base;

10 a plurality of separate projectile back storage compartments between said front of said base and said back of said base with parallel center lines, said projectile back storage compartments associated on a

15 one-to-one basis with said projectile openings and each having a length and transverse dimension to be operable to hold a projectile with at least one-half of the ogive of the projectile extending out from

20 said front of said base; and

front securing means operable with said back securing means for removably securing said cover to said front of said base.

- 36 -

21. The apparatus of Claim 20 wherein said
base is operable to secure alternate projectile
front protecting devices to said front of said base;
one of said front projecting devices being said
5 cover; the other of said front protecting devices
being a projectile locking front having locking
means selectively operable to secure projectiles
against movement out of said projectile back storage
compartments and selectively operable to allow
10 projectile removal from said projectile back storage
compartments with the projectile locking front
disposed at said front of said base.

22. A method for storing projectiles and
making projectiles accessible for usage, the steps
comprising:

5 I. placing a plurality of projectiles in a
projectile container having a base and a
cover, said base including:
a back;
a front parallel to said back and
having a plurality of projectile
10 openings therein;
four sides extending from said back
of said base to said front of said
base;
a plurality of separate projectile
15 back storage zones between said front
of said base and said back of said
base with parallel center lines, said
projectile back storage zones
associated on a one-to-one basis with
20 said projectile openings; and
front securing means operable for
removably securing a projectile front

- 37 -

protecting device to said front of
said base; and
25 said cover including:
a cover body having a closed off
front,
a back,
30 four sides extending from said front
of said cover body to said back of
said cover body;
a plurality of projectile front
storage zones disposed in said cover
body and extending from said back of
35 said cover body to said front of said
cover body;
back securing means operable with
said front securing means for
removably securing said cover to the
40 base with said plurality of
projectile back storage zones in the
base corresponding on a one-to-one
basis with said front storage zones
with each projectile having its back
45 disposed in one of said projectile
back storage zones and its front
disposed in the corresponding front
storage zone; and
wherein said projectiles are inaccessible
50 with said cover on said front of said
base; and
II. removing said cover when said
projectiles are to be made ready for
access; and
55 III. securing a projectile locking front to
said base, said projectile locking front
including:

- 38 -

60 a body having a front and a back;
a plurality of projectile front
storage zones in said body
corresponding on a one-to-one basis
with said projectile back storage
zones and extending from said back to
said front,
65 each of said front storage zones
in said projectile locking front
having an open back to allow
projectiles to extend outwardly
therefrom and an open front to allow
70 projectiles to extend outwardly
therefrom;
locking means mounted to said body
and selectively operable to secure
projectiles against movement out the
75 front of said front storage zones in
said projectile locking front and
selectively operable to allow
projectile removal out of the front
of said front storage zones in said
80 projectile locking front; and
base securing means on said body
operable for removably securing said
base to said back of said body; and
wherein said projectile locking front allows access
85 and removal of said projectiles while it is secured
to said base.

23. The method of Claim 22 wherein said
cover and the base are together operable to compress
at least one resilient seal disposed therebetween
and to protect the plurality of stored projectiles
5 against nuclear, biological, and chemical agents.

- 39 -

24. The method of Claim 22 wherein said cover further includes at least one control on said cover body operable for activating and deactivating said back securing means.

25. The method of Claim 22 wherein each of said projectile front storage zones of said projectile locking front is within a corresponding front storage tube.

26. The method of Claim 22 wherein said locking means includes a securing portion for each of said front storage zones, each securing portion selectively operable to prevent a projectile from moving out of said front storage zones of said projectile locking front.

27. The method of Claim 22 wherein at least one-half of the ogives of the stored projectiles project frontwardly out from the base.

AMENDED CLAIMS

[received by the International Bureau on 21 October 1985 (21.10 85);
original claims 1-27 replaced by amended claims 1-13 (5 pages)]

1. A magazine for carrying and/or storing
projectiles including a base (14) for holding back
portions of a plurality of projectiles (16) and a
front projectile locking member (90) having a front
5 and a back; said front member (90) including a
plurality of projectile front storage zones (118)
extending from said back to said front, each of
said front storage zones (118) having an open back
to allow projectiles to extend outwardly therefrom
10 and an open front to allow projectiles to extend
outwardly therefrom; and being characterized by
locking means (138) mounted to said member (90) and
selectively operable to secure the projectiles (16)
against movement out the front of said storage
15 zones (118) and selectively operable to allow
removal of projectiles (16) out of the front of
said storage zones; and base securing means (98,
100, 102) on said member (90); operable for
removably securing the base (14) to said back of
20 said member (90), the base (14) having a plurality
of projectile back storage zones (18) associated on
a one-to-one basis with said front storage zones
and operable to hold the backs of projectiles (16)
which have their noses extending into said
25 projectile front member (90) storage zones (118).

2. The magazine of Claim 1 wherein said
locking means includes a securing portion (122F,
122R) for each of said front storage zones, each
securing portion selectively operable to prevent a
5 projectile from moving out of one of said front
storage zones.

3. The magazine of Claim 1 wherein each of said back storage zones (18) has a length and transverse dimension so as to hold a projectile with at least one-half of the ogive of the projectile extending out from said front of said base.

4. The magazine of Claim 1 wherein said base further comprises securing means operable for removably securing a projectile front protecting cover (12) to said front of said base, each cover (12) adapted to enclose at least the front one-half of the ogives of projectiles extending out of said back storage zones, and wherein movement of the entire cover away from said base is necessary to allow removal of projectiles from said back storage zones.

5. The magazine of Claim 4 including at least one resilient seal (84), said base and the cover together being operable to compress the resilient seal (84) disposed therebetween and to protect a plurality of projectiles against nuclear, biological, and chemical agents.

6. The magazine of Claim 1 wherein each of said back storage zones is isolated from the other back storage zones.

7. The magazine of Claim 1 wherein said base (14) includes a plastic outer molding (52), a plastic inner molding (24), and a metal insert frame (36) in between said plastic outer molding and said plastic inner molding; and wherein said plastic inner molding has a plurality of tubes (18) each of which defines one of said back storage zones.

8. The magazine of Claim 1 comprising a base for holding back portions of a plurality of projectiles and including:

5 wherein said cover includes a body having a closed off front and a plurality of projectile front storage zones disposed in said body and extending from the back of said body to the front of said body; and securing means operable with said front member securig means for removably securing
10 said cover to said base, said cover being secured to said base such that the plurality of back storage compartments in said base are associated on a one-to-one basis with said projectile front storage zones such that each projectile front
15 storage zone may hold the front of a projectile having its back extending into the associated back storage compartment.

9. The magazine of Claim 8 further comprising a plurality of resilient seals disposed for compression between said cover and said base and associated on a one-to-one basis with said
5 projectile openings.

10. The magazine of Claim 8 wherein said cover further includes:

at least one control on said cover body operable for activating and deactivating said back
5 securing means.

11. The magazine of Claim 1 further including a cover operable to enclose at least the front one-half of the ogives of projectiles extending out from a base, and having a plurality of projectile
5 front storage zones disposed in said cover and extending from said back to said front; back securing means operable for removably securing

10 said cover to the base with a plurality of
projectile back storage compartments in the base
corresponding on a one-to-one basis with said front
storage zones such that each front storage zone may
hold the front of a projectile having its back
extending into the corresponding back storage
15 compartment; and at least one control on said cover
operable for activating and deactivating said back
securing means; and wherein said cover and the base
are together operable to compress at least one
resilient seal disposed therebetween and to protect
20 a plurality of projectiles against nuclear,
biological, and chemical agents.

12. The magazine of Claim 11 wherein said
base for holding back portions of a plurality of
projectiles further includes a plurality of
separate projectile back storage compartments
5 between the front of said base and the back of said
base with parallel center lines, said projectile
back storage compartments being associated on a
one-to-one basis with said projectile openings and
each having a length and transverse dimension to be
10 operable to hold a projectile with at least
one-half of the ogive of the projectile extending
out from said front of said base; and front
securing means for removably securing said cover to
said front of said base.

13. The magazine of Claim 12 wherein said
base is operable to secure alternate projectile
front protecting devices to said front of said
base; one of said front projecting devices being
5 said cover; the other of said front protecting
devices being said projectile locking front member
having locking means selectively operable to secure
projectiles against movement out of said

10 projectile back storage compartments and
selectively operable to allow projectile removal
from said projectile back storage compartments with
the projectile locking front disposed at said front
of said base.

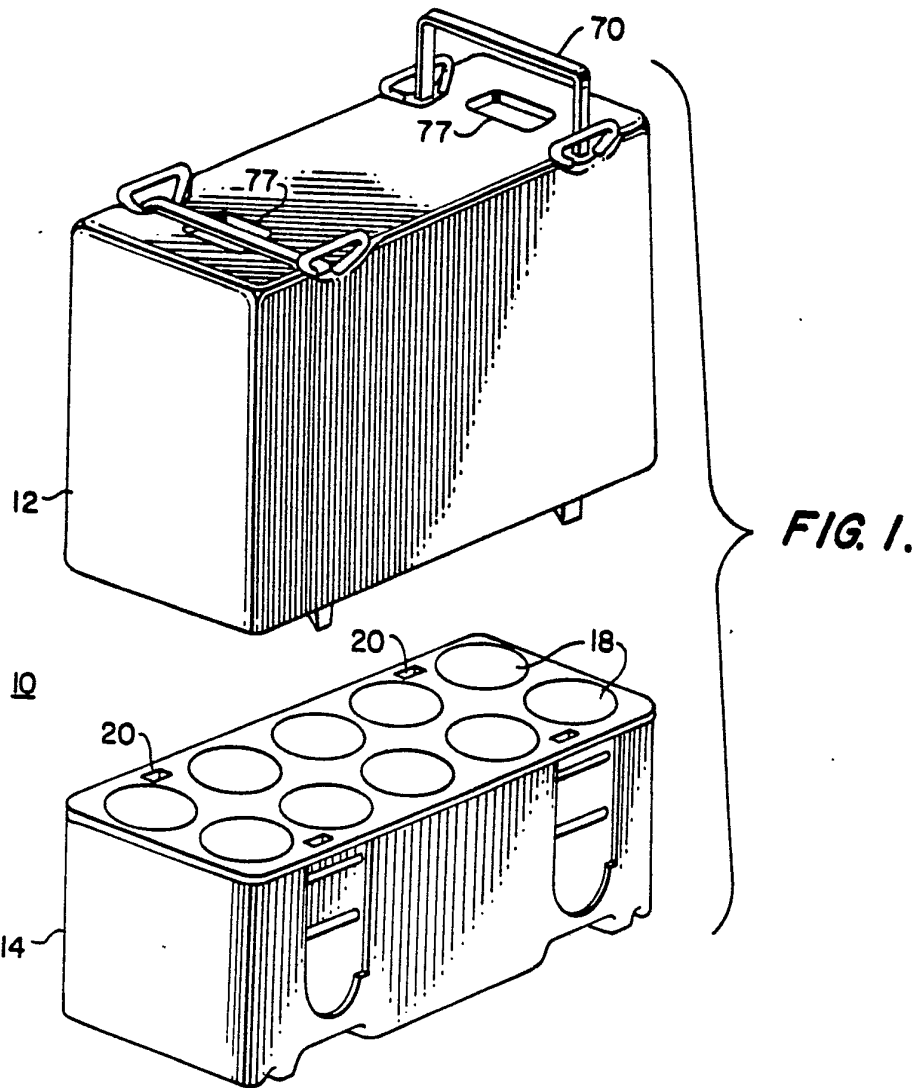

FIG. 2.

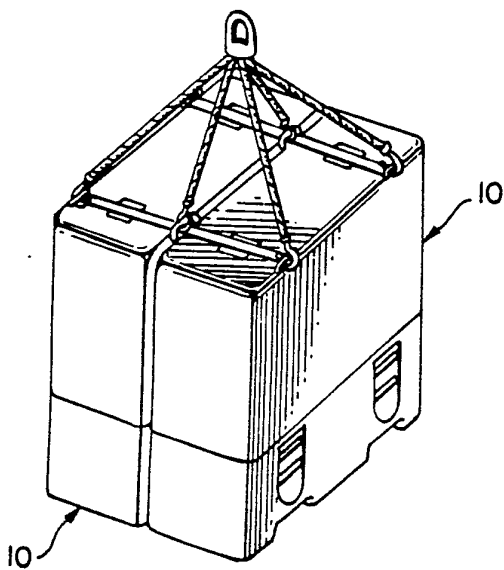
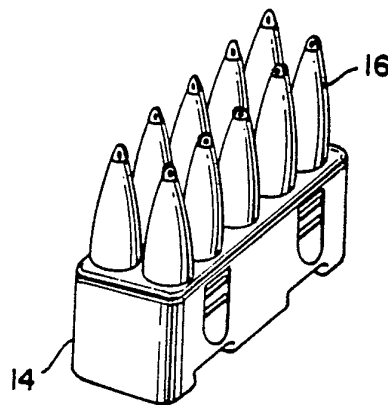

FIG. 3.



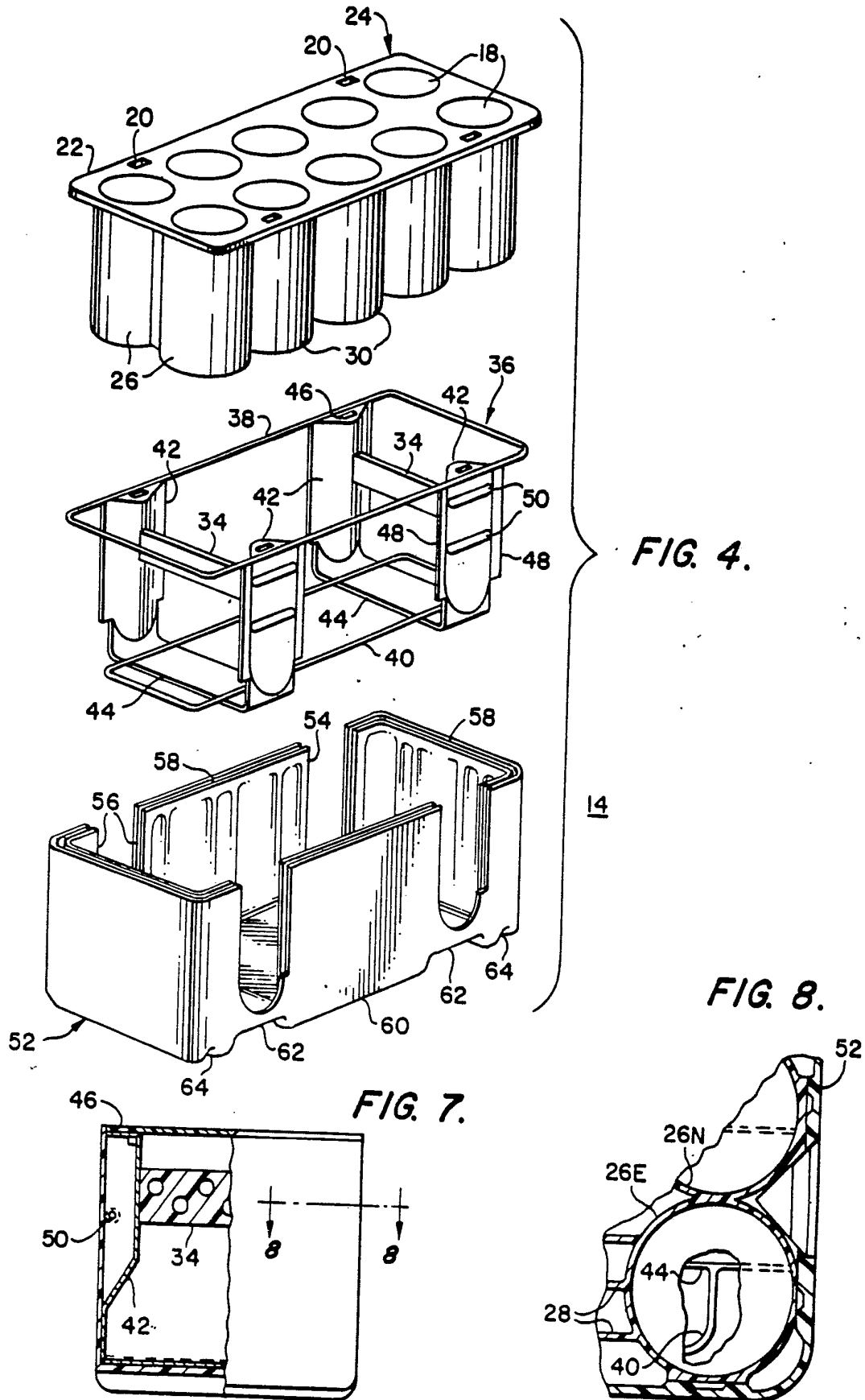

FIG. 13.

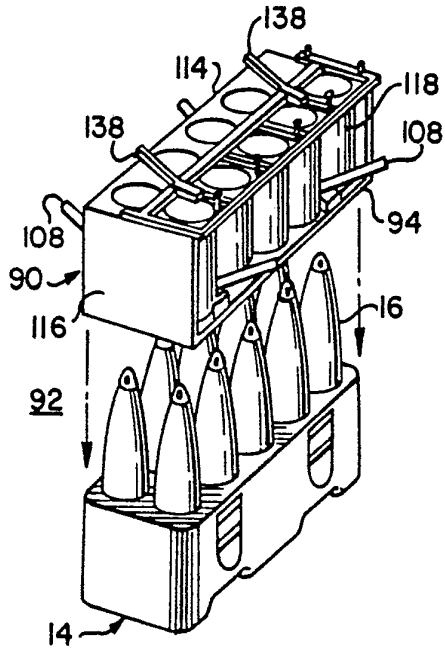

FIG. 14.

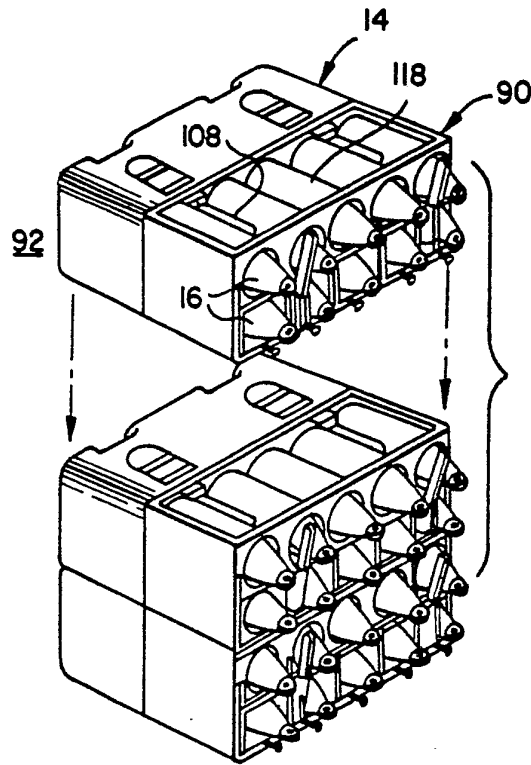

FIG. 5.

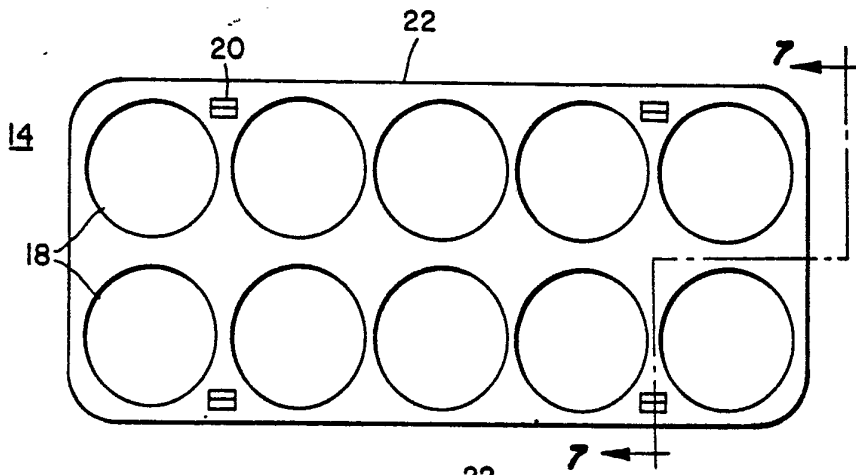

FIG. 6.

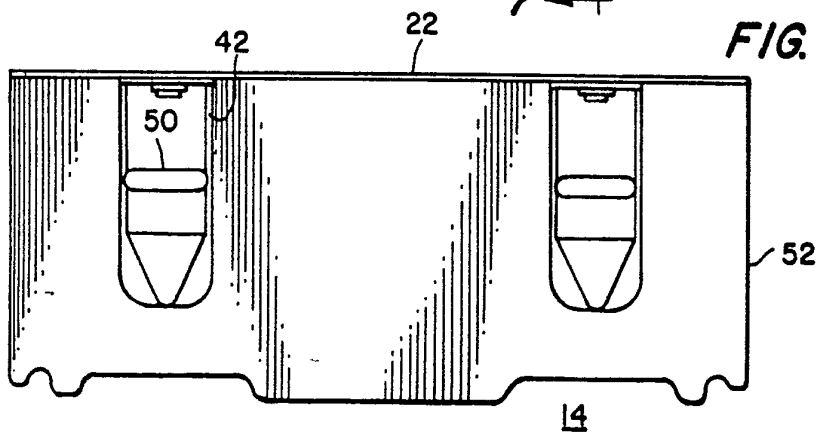

FIG. 9.

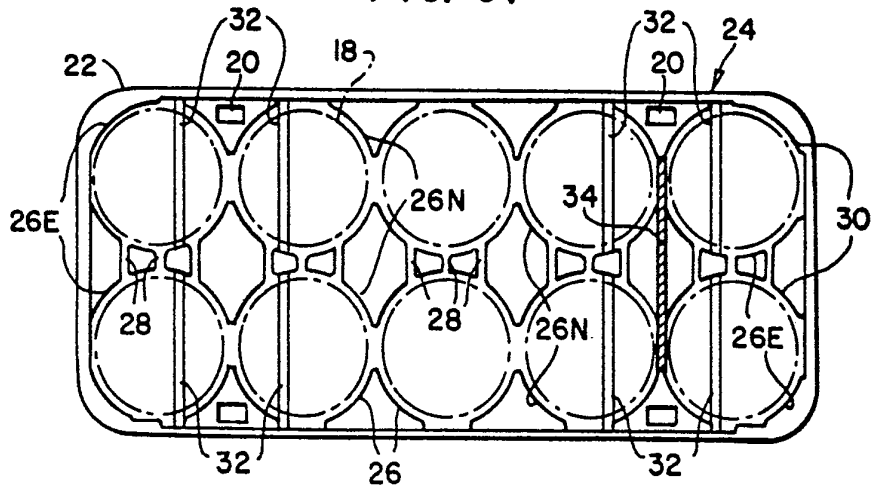
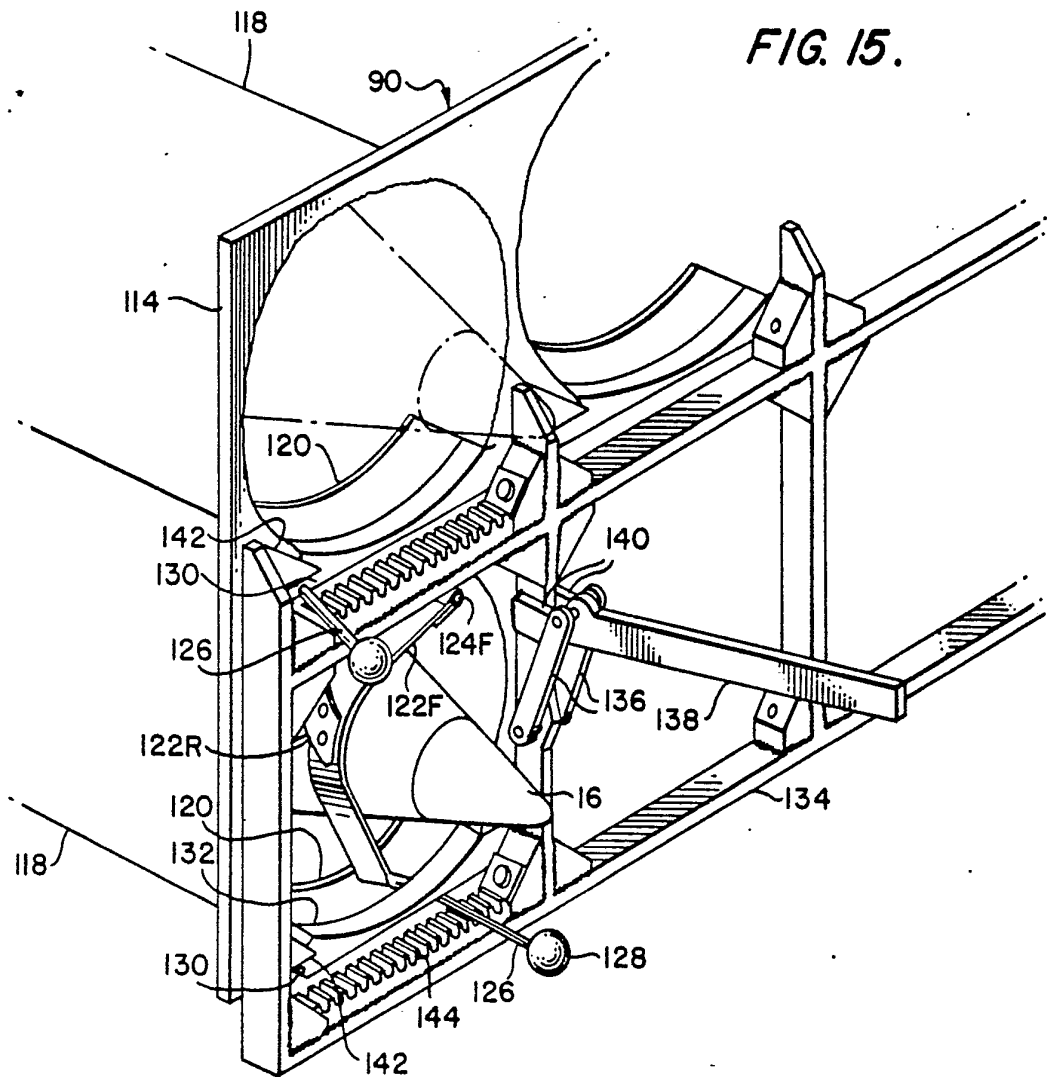
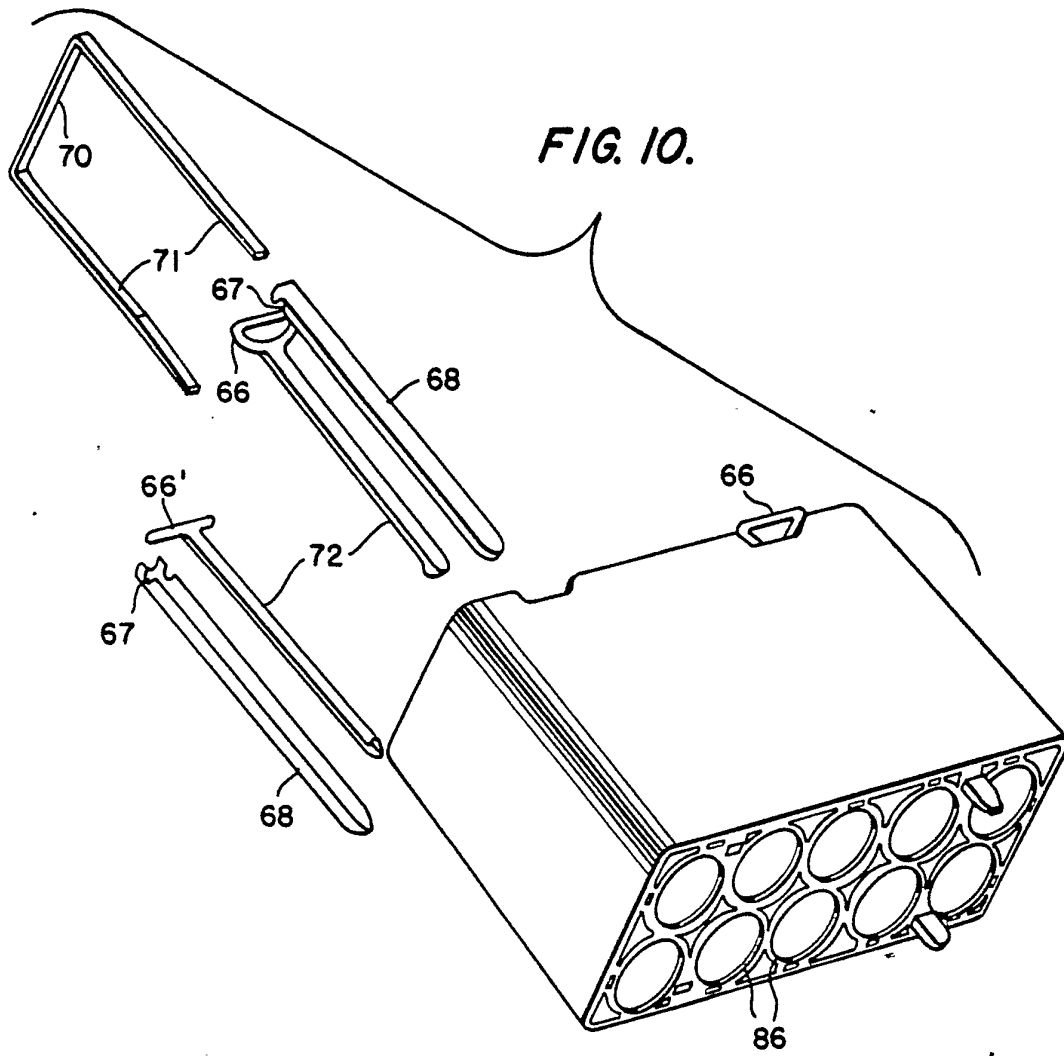

FIG. 15.





INTERNATIONAL SEARCH REPORT

International Application No PCT/US85/01225

I. CLASSIFICATION OF SUBJECT MATTER (if several classification symbols apply, indicate all) ³		
According to International Patent Classification (IPC) or to both National Classification and IPC Int. Cl. 4: F42B 37/00 U.S. Cl: 220/3; 220/443		
II. FIELDS SEARCHED		
Minimum Documentation Searched ⁴		
Classification System	Classification Symbols	
U.S.	206/3,443 89/1.816,1.817	
Documentation Searched other than Minimum Documentation to the Extent that such Documents are Included in the Fields Searched ⁵		
III. DOCUMENTS CONSIDERED TO BE RELEVANT ¹⁴		
Category *	Citation of Document, ¹⁶ with indication, where appropriate, of the relevant passages ¹⁷	Relevant to Claim No. ¹⁸
A	US, A, 1,120,244, Published 08 December 1914 (Sachtleben)	1-27
A	US, A, 1,218,814, Published 13 March 1917 (Steinmetz)	1-27
A	US, A, 1,991,481, Published 19 February 1935 (Woodbridge)	1-27
A	US, A, 2,371,663, Published 20 March 1945 (Woodberry et al)	1-27
A	US, A, 3,185,035, Published 25 May 1965 (Gregory-Humphries)	1-27
A	US, A, 3,515,321, Published 02 June 1970 (Webster)	1-27
A	US, A, 3,710,677, Published 16 January 1973 (Mayer)	1-27
	(see second sheet)	
<p>* Special categories of cited documents: ¹⁵</p> <p>"A" document defining the general state of the art which is not considered to be of particular relevance</p> <p>"E" earlier document but published on or after the international filing date</p> <p>"L" document which may throw doubts on priority claim(s) or which is cited to establish the publication date of another citation or other special reason (as specified)</p> <p>"O" document referring to an oral disclosure, use, exhibition or other means</p> <p>"P" document published prior to the international filing date but later than the priority date claimed</p> <p>"T" later document published after the international filing date or priority date and not in conflict with the application but cited to understand the principle or theory underlying the invention</p> <p>"X" document of particular relevance; the claimed invention cannot be considered novel or cannot be considered to involve an inventive step</p> <p>"Y" document of particular relevance; the claimed invention cannot be considered to involve an inventive step when the document is combined with one or more other such documents, such combination being obvious to a person skilled in the art.</p> <p>"&" document member of the same patent family</p>		
IV. CERTIFICATION		
Date of the Actual Completion of the International Search ²	Date of Mailing of this International Search Report ³	
22 August 1985	<div style="font-size: 2em; font-weight: bold; margin: 0;">19 SEP 1985</div>	
International Searching Authority ¹	Signature of Authorized Officer ²⁰	
ISA/US	Allan N. Shoap <i>Allan N. Shoap</i>	

FURTHER INFORMATION CONTINUED FROM THE SECOND SHEET

A	US, A, 3,939,967, Published 24 February 1976 (Tenney et al)	1-27
A	US, A, 3,988,961, Published 02 November 1976 (Banta et al)	1-27
A	US, A, 4,222,484, Published 16 September 1980 (Howe)	1-27
A	US, A, 4,286,708, Published 01 September 1981 (Porzel)	1-27
A	US, A, 4,356,913, Published 02 November 1982 (Moraine)	1-27

V. OBSERVATIONS WHERE CERTAIN CLAIMS WERE FOUND UNSEARCHABLE ¹⁰

This international search report has not been established in respect of certain claims under Article 17(2) (a) for the following reasons:

1. Claim numbers because they relate to subject matter ¹² not required to be searched by this Authority, namely:
2. Claim numbers because they relate to parts of the international application that do not comply with the prescribed requirements to such an extent that no meaningful international search can be carried out ¹³, specifically:

VI. OBSERVATIONS WHERE UNITY OF INVENTION IS LACKING ¹¹

This International Searching Authority found multiple inventions in this international application as follows:

1. As all required additional search fees were timely paid by the applicant, this international search report covers all searchable claims of the international application:
2. As only some of the required additional search fees were timely paid by the applicant, this international search report covers only those claims of the international application for which fees were paid, specifically claims:
3. No required additional search fees were timely paid by the applicant. Consequently, this international search report is restricted to the invention first mentioned in the claims; it is covered by claim numbers:
4. As all searchable claims could be searched without effort justifying an additional fee, the International Searching Authority did not invite payment of any additional fee.

Remark on Protest

- The additional search fees were accompanied by applicant's protest.
- No protest accompanied the payment of additional search fees.