



US 20040223439A1

(19) **United States**

(12) **Patent Application Publication**

Tieke et al.

(10) **Pub. No.: US 2004/0223439 A1**

(43) **Pub. Date: Nov. 11, 2004**

(54) **METHODS AND DEVICES FOR RECORDING MARKS ON A RECORDING SURFACE OF AN OPTICAL RECORD CARRIER**

(30) **Foreign Application Priority Data**

May 11, 2000 (EP)..... 00201680.6

(76) Inventors: **Benno Tieke, Eindhoven (NL); Robert Woudenberg, Eindhoven (NL)**

Publication Classification

(51) **Int. Cl.⁷** **G11B 7/00**

(52) **U.S. Cl.** **369/59.11; 369/116; 369/59.12**

Correspondence Address:

PHILIPS INTELLECTUAL PROPERTY & STANDARDS

P.O. BOX 3001

BRIARCLIFF MANOR, NY 10510 (US)

(57) **ABSTRACT**

The invention relates to methods and devices for forming marks and lands by applying a radiation beam (32) to a recording surface (301) of an optical record carrier (30). Recording strategies are proposed for recording information at high recording speeds. An intermediate power level (P_1 , P_2) is introduced in between the bottom power level (P_0) and the write power level (P_w), its value being dependent on the length of the preceding land (151, 152, 153). A raised write power level (P_{R1} , P_{R2}) is also proposed, its value being dependent on the length of the mark to be recorded (241, 242, 243).

(21) Appl. No.: **10/859,691**

(22) Filed: **Jun. 3, 2004**

Related U.S. Application Data

(63) Continuation-in-part of application No. 10/418,602, filed on Apr. 18, 2003, now Pat. No. 6,765,854.

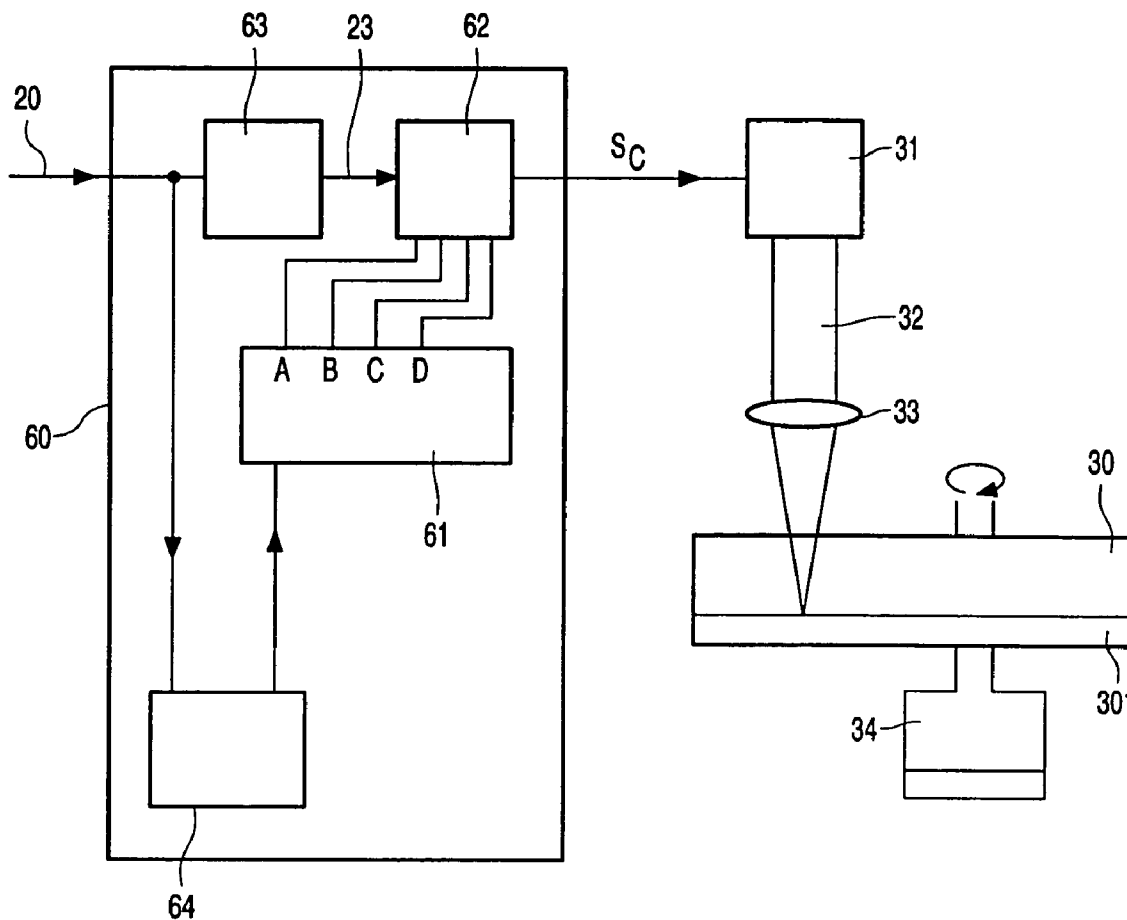

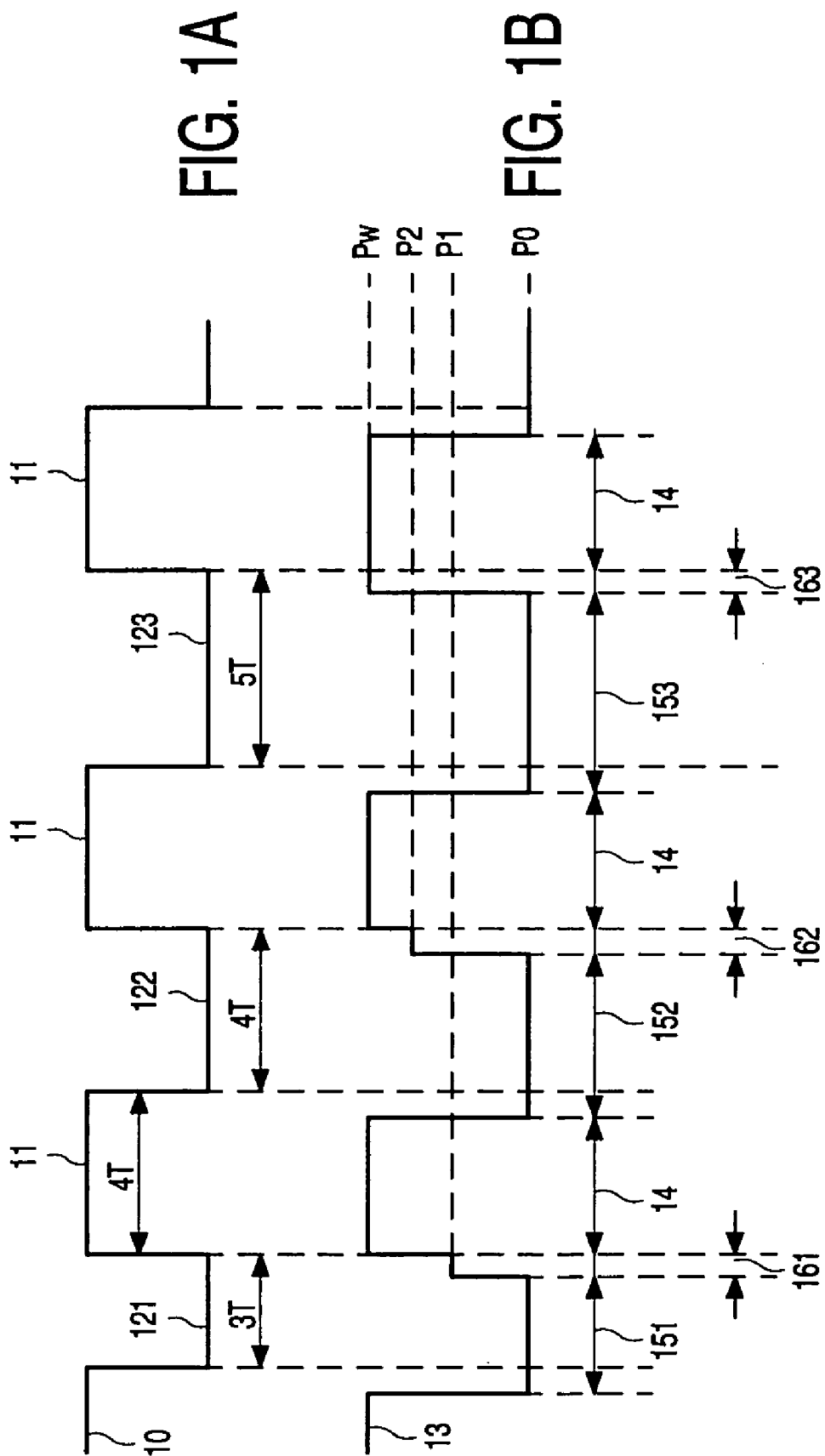
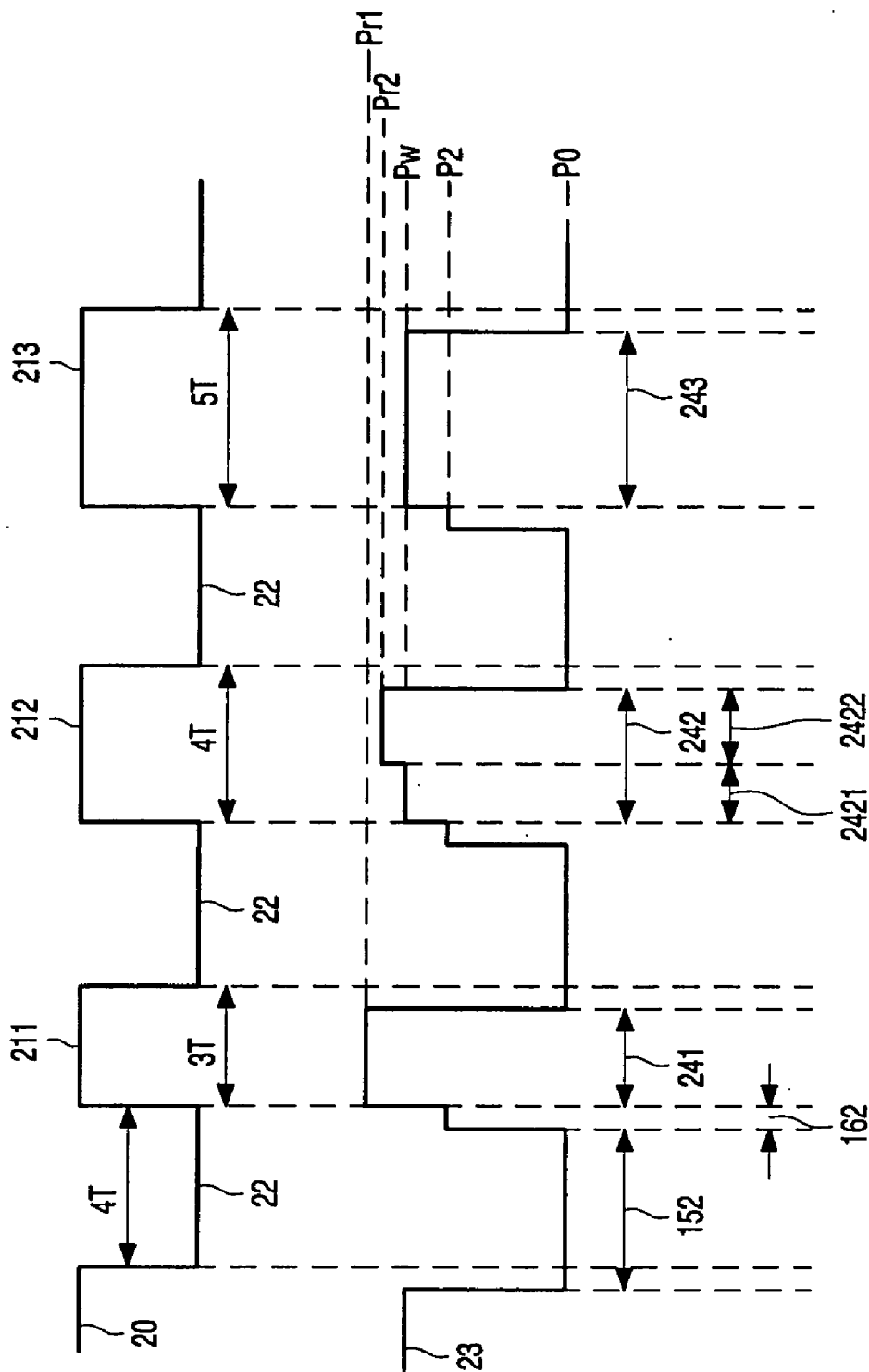

FIG. 2A

FIG. 2B



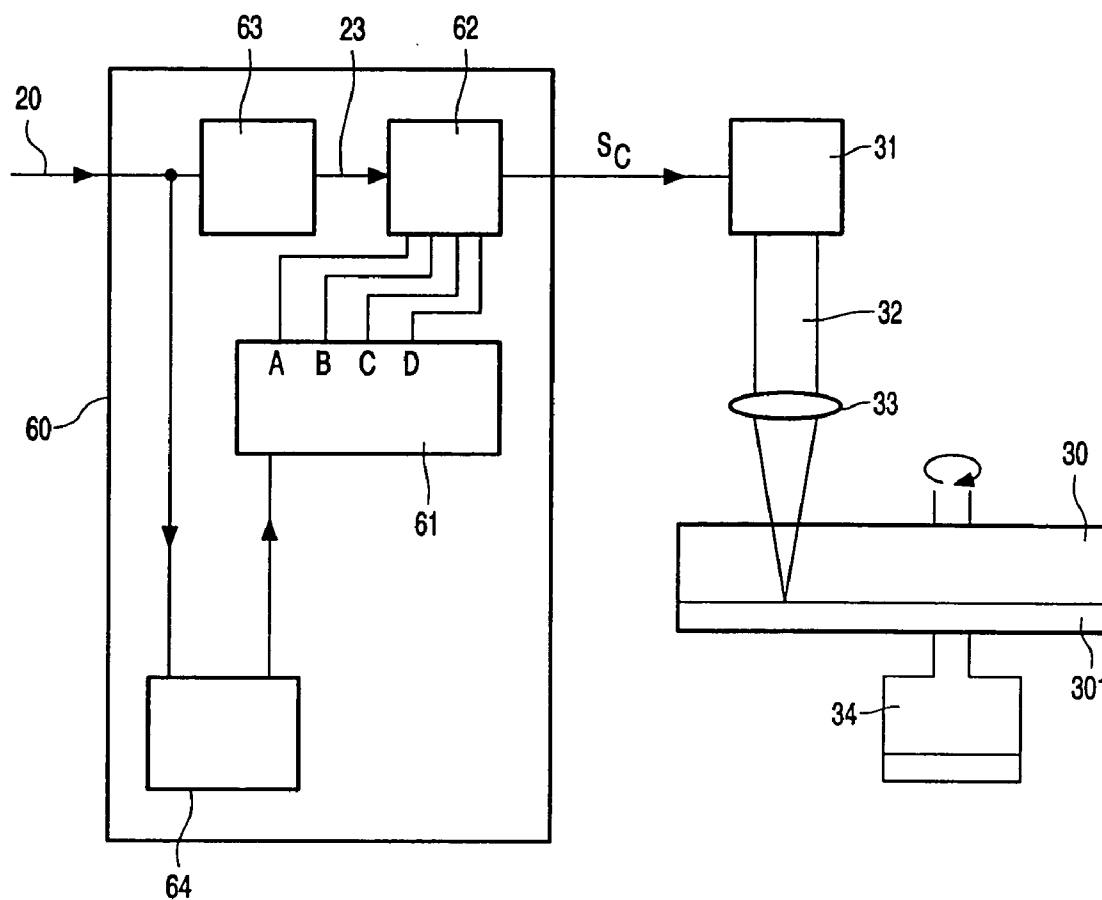

FIG. 3

METHODS AND DEVICES FOR RECORDING MARKS ON A RECORDING SURFACE OF AN OPTICAL RECORD CARRIER

[0001] The invention relates to an optical record carrier recording method for forming marks and lands by applying a radiation beam to a recording surface of an optical record carrier, the radiation beam for each mark to be recorded being set to at least one write power level capable of forming a mark during a write power irradiation period and being set for each land section between the marks, to at least one bottom power level incapable of forming a mark during a bottom power irradiation period.

[0002] The invention also relates to an optical record carrier recording method for forming marks and lands by applying a radiation beam to a recording surface of an optical record carrier, the marks having a time length of nT , where T represents the time length of one period of a reference clock in a data signal and n represents a predetermined natural number.

[0003] The invention also relates to optical recording devices for carrying out such methods.

[0004] A recording method of the kind set forth in the preamble is known from the Compact Disc Recordable (CD-R) System Description (also known as the Orange-book). A mark is formed by applying a radiation beam having a write power level, P_w , to a recording surface of an optical record carrier during a write power irradiation period. The time length of the write power irradiation period depends on the length of the mark to be recorded. The length of a mark is represented by a parameter nT , where T represents the time length of one period of a reference clock in a data signal and n represents a predetermined natural number. For a CD-R system n is in a range from 3 to 11.

[0005] The nominal constant linear velocity speed (CLV-speed) of the CD system is between 1.2 and 1.4 m/sec. In a CD-R system this nominal constant linear velocity speed will result in an average EFM (Eight to Fourteen Modulation) clock frequency of 4.3218 MHz. However the system is also specified to run at higher speeds such as for example four times the nominal speed (4 \times). Running at higher speeds, the write power level is enhanced with an extra power, ΔP , at the beginning of the write power irradiation period. By applying this extra power, the degradation of the jitter due to the high speed is somewhat reduced. The jitter is the standard deviation of the time difference between level transitions in a digitized read signal and the corresponding transitions in a clock signal, the time difference being normalized by the duration of one period of said clock.

[0006] It is a drawback of the known method that it does not allow a sufficient reduction of the jitter in the read signal obtained from reading marks recorded by using the known method, especially when the marks are recorded at high speeds such as, for example, eight times the nominal speed (8 \times).

[0007] It is an object of the invention to provide a method of recording marks of the kind described in the opening paragraph which offers reduced jitter.

[0008] This object is achieved by a method as described in the preamble which is characterized in that the radiation beam is set to at least one intermediate power level after the

bottom power irradiation period and before the write power irradiation period, the intermediate power level being higher than the bottom power level and being set in accordance with a time length of the preceding bottom power irradiation period.

[0009] Marks are recorded on a recording surface by applying a radiation beam having a sufficiently high write power level to a location on the recording surface of an optical record carrier, thus temporarily increasing the local temperature of the recording surface. However, when recording a mark, the temperature of the actual location on the recording surface is pre-heated because of the recording of a previous mark. This so-called pre-heat effect results in an increase of particularly the leading edge jitter of the mark to be recorded. Furthermore, the recording of a mark slows down the cooling-down of the location of the previously recorded mark. This so-called post-heat effect results in an increase of particularly the trailing edge jitter of the previously recorded mark.

[0010] The influence of these thermal interference effects (that is, the pre-heat and the post-heat effect) depends on the distance between the actual location on the recording surface where a mark is to be recorded and the location of the previously recorded mark. Therefore, the influence of the thermal interference effects depends on the length of the land, l_L , between the marks. This length can be expressed in the time length of the bottom power irradiation period, t_L , because of the relation: $t_L = l_L / \text{actual CLV-speed}$.

[0011] The thermal interference effects can be reduced by introducing an intermediate power level after the bottom power irradiation period and before the write power irradiation period, the intermediate power level being dependent on the time length, t_L , of the preceding bottom power irradiation period.

[0012] Version of the method according to the invention is characterized in that an intermediate power level following a first bottom power irradiation period having a time length of $(n+1)T$ is set to be larger than or equal to an intermediate power level following a second bottom power irradiation period having a time length of nT .

[0013] The thermal interference effects between two marks decrease when the distance between the marks increases. Therefore the compensation for these effects obtained by introducing the intermediate power level needs to be less for larger distances than for shorter distance. Therefore, the intermediate power level will be closer to the write power level in the case of long distances between the marks.

[0014] A preferred version of the method according to the invention is characterized in that an intermediate power level following a first bottom power irradiation period having a time length of $3T$ is set within a range of from 0.50 to 0.80 times the write power level, that an intermediate power level following a second bottom power irradiation period having a time length of $4T$ is set within a range of from 0.75 to 0.95 times the write power level, and that an intermediate power level following a third bottom power irradiation period having a time length of mT , where m represents a predetermined natural number larger than 4, is set so as to be substantially equal to the write power level.

[0015] From experiments it was concluded that, when recording at a speed of eight (8 \times) to sixteen (16 \times) times the

nominal speed, reduction of the jitter is obtained when the intermediate power level is within the above mentioned ranges. A particularly reduction of the jitter is obtained when an intermediate power level following a first bottom power irradiation period having a time length of $3T$ is set so as to be substantially equal to 0.65 times the write power level (11) and when an intermediate power level following a second bottom power irradiation period having a time length of $4T$ is set so as to be substantially equal to 0.85 times the write power level. However, the optimal setting of the intermediate power levels depend on properties of the optical record carrier used. Therefore, it is suggested that an Optimal Power Calibration (OPC) method should be used to determine the optimal settings of the intermediate power levels for each individual optical record carrier.

[0016] Version of the method according to the invention is characterized in that the time length of the intermediate power irradiation period is substantially equal to $1/4T$.

[0017] Although the time length of the intermediate power irradiation period may be set to any value, such as for example $1/8T$, $1/2T$ and $1T$, results are obtained for all recording speed when the intermediate power irradiation period is set so as to be substantially equal to $1/4T$.

[0018] At the nominal CLV-speed T represents a time length of 231.4 ns ($=1/4.3218$ MHz). At a higher speed of eight times the nominal speed ($8\times$) T represents a time length of 28.9 ns. An intermediate power level maintained for a time length of 7.2 ns ($=T/4$ at eight times nominal speed) can be easily and accurately obtained by means of contemporary electronics. Alternative methods for reducing the jitter employ a time shift of the leading-edge of the write power level. These time shifts typically occur in steps of $T/20$. At nominal speed these time shifts of 11.6 ns can also be obtained using contemporary electronics. However, at eight times the nominal speed ($8\times$) these time shifts would be in the range of 1.4 ns, being a value being difficult to obtain accurately. At an even higher recording speed of sixteen times the nominal speed ($16\times$), the time shifts would be in the range of 0.7 ns while the intermediate power level should be maintained for a time length of 3.6 ns

[0019] The object is also achieved by means of a method according to the invention which has the features as described in claim 7.

[0020] A further reduction of the jitter is obtained by applying a raised write power level when recording the marks, the raised power level being set in accordance with the time length of the mark to be recorded. For the shorter marks the raised power level is applied over the entire write power irradiation period. For the somewhat longer marks the raised power level is only applied to a portion at the end of the write power irradiation period. The time length of this portion may be equal for all marks or, alternatively, can be made dependent on the length of the mark to be recorded. For the longer marks no raised power level is applied.

[0021] A preferred version of the method according to the invention has the features as described in claim 8.

[0022] From experiments it was concluded that reduction of the jitter is obtained when the raised write power levels are within the specified ranges. A particularly reduction of the jitter is obtained when the first raised write power level, when recording a mark having a time length of $3T$, is set so

as to be substantially equal to 1.10 times the write power level and when the second raised write power level when recording a mark having a time length of $4T$, is set so as to be substantially equal to 1.04 times the write power level.

[0023] Although the range specified for the first raised write power level overlaps with the range specified for the second raised write power level, the first raised power level is in general set to a higher value in comparison with the second raised write power level.

[0024] It is a further object of the invention to provide an optical recording device for carrying out the methods according to the invention.

[0025] This object is achieved by an optical recording device which has the features as described in claim 9. This object is also achieved by providing an optical recording device which has the features as described in claim 11.

[0026] Although the invention is explained by using a CD-R system as an example, it will be apparent to those skilled in the art that the invention may also be applied to alternative optical recording systems.

[0027] The objects, features and advantages of the invention will be apparent from the following, more specific description of embodiments of the invention as illustrated in the accompanying drawings; therein:

[0028] FIG. 1 shows diagrams of a first version of a method according to the invention,

[0029] FIG. 2 shows diagrams of a second version of a method according to the invention, and

[0030] FIG. 3 shows a diagram of an optical recording device according to the invention.

[0031] FIG. 1a shows a data signal 10. When this data signal 10 is recorded on an optical record carrier, the 'high' periods 11 are recorded as marks and the 'low' periods 121, 122 and 123 are recorded as lands (e.g. unwritten areas between the marks). The time lengths of these periods in the data signal are expressed by the number of periods, T , of a reference clock in the data signal. In this example, the time length of the 'high' periods 11 is $4T$. The time length of the 'low' periods 121, 122, and 123 is $3T$, $4T$ and $5T$, respectively.

[0032] FIG. 1b shows a control signal 13 for controlling the power of the radiation beam. When a mark is recorded, the control signal 13, and hence the power of the radiation beam, is set to a write power level P_w during a write power irradiation period 14. The duration of the write power irradiation period 14 is related to the corresponding 'high' period 11 in the data signal 10. In this example the duration of the write power irradiation period 14 is set to be $4T$. When a land is recorded the control signal 13, and hence the power of the radiation beam, is set to a bottom power level P_0 during a bottom power irradiation period, the duration of which is related to the corresponding 'low' period in the data signal 10. In this example the duration of the bottom power irradiation periods 151, 152 and 153 is set to be $3T$, $4T$ and $5T$, respectively.

[0033] When a mark is recorded following a bottom power irradiation period 151 corresponding to a 'low' period 121 of $3T$, the control signal 13, and hence the power of the radiation beam, is set to a first intermediate power level P_1

for the duration of a first intermediate power irradiation period **161**. When a mark is recorded following a bottom power irradiation period **152** corresponding to a 'low' period **122** of $4T$, the control signal **13** is set to a second intermediate power level P_2 for the duration of a second intermediate power irradiation period **162**, and when a mark is recorded following a bottom power irradiation periods **153** corresponding to a 'low' period **123** of $5T$, the control signal **13** is set to the write power level P_w for the duration of a third intermediate power irradiation period **163**. When a mark is recorded following a bottom power irradiation period corresponding to a 'low' period of from $6T$ to $11T$, the intermediate power level is also set to the write power level P_w . Although the duration of the intermediate power irradiation periods **161**, **162** and **163** may be different, reduction of the jitter is obtained when they all have value equal to $T/4$.

[0034] FIG. 2a shows a data signal **20**. When this data signal **20** is recorded on an optical record carrier, the 'high' periods **211**, **212** and **213** are recorded as marks and the 'low' periods **22** are recorded as lands (e.g. unwritten areas between the marks). The time length of these periods in the data signal are expressed by the number of periods, T , of a reference clock in the data signal. In this example, the time length of the 'high' periods **211**, **212** and **213** is $3T$, $4T$ and $5T$, respectively. The time length of the 'low' periods **22** is $4T$.

[0035] FIG. 2b shows a control signal **23** for controlling the power of the radiation beam. When a land is recorded the control signal **23**, and hence the power of the radiation beam, is set to a bottom power level P_0 during a bottom power irradiation period, the duration of which is related to the corresponding 'low' period **22** in the data signal **20**. In this example the duration of the bottom power irradiation period **152** is set to be $4T$. After the bottom power irradiation period **152** the control signal **23** is set to an intermediate power level P_2 for the duration of an intermediate power irradiation period **162**. When the duration of the bottom power irradiation period changes, the setting of the intermediate power level changes accordingly as explained during the discussion of FIG. 1.

[0036] The duration of the write power irradiation period is related to the corresponding 'high' period **211**, **212** and **213** in the data signal **20**. In this example the duration of the write power irradiation periods **241**, **242** and **243** is set to be $3T$, $4T$ and $5T$, respectively.

[0037] When a mark corresponding to a 'high' period **211** of $3T$ is recorded, the control signal **23**, and hence the power of the radiation beam, is set to a first raised write power level P_{R1} for the duration of a first write power irradiation period **421**. When a mark corresponding to a 'high' period **212** of $4T$ is recorded, the control signal **23** is set to a second raised write power level P_{R2} during a second portion **2422** of a second write power irradiation period **422** and to the write power level P_w during a first portion **2421** of the second write power irradiation period **422**. When a mark corresponding to a 'high' period **213** of $5T$ is recorded, the control signal **23** is set to the write power level P_w for the duration of a third write power irradiation period **423**. When a mark corresponding to a 'high' period of from $6T$ to $11T$ is recorded, the control signal **23** is also set to the write power level P_w during the write power irradiation period.

[0038] FIG. 3 shows an optical recording device according to the invention for recording a data signal **20** on the

recording surface **301** of a disc-shaped optical record carrier **30**. The optical record carrier is rotated around its center by a motor **34**. A radiation beam **32** is generated by a radiation source **31** and focused onto the recording surface **301** by a lens **33**.

[0039] The data signal **20** is connected to control means **60**. A current source **61** within the control means **60** has four outputs, A, B, C and D. Output A provides a current which, when fed to the radiation source **31** through a control signal S_C , will produce the radiation beam **32** having a write power level P_w . Likewise, outputs B, C and D provide currents resulting in the raised write power level, the bottom power level P_0 and the intermediate power level, respectively. The current of each output A, B, C and D can be selected by a switch-unit **62** within the control means **60**. The switch-unit **62** is operated by a pattern generator **63** controlled by the data signal **20**. The pattern generator **63** transforms the data signal **20** into a control signal **23**.

[0040] The control means **60** also comprise setting means **64** for setting the current of the outputs B and D of the current source **61**. The current of output B of the current source **61** is set in dependence on the length of the 'high' period, **211**, **212** and **213**, to be recorded. Thus, by setting the current of output B, the raised write power level is set in dependence on the length of the mark to be recorded. The current of output D of the current source **61** is set in dependence on the length of the 'low' period **22** preceding the 'high' period to be recorded. Thus, by setting the current of output D, the intermediate power level is set in dependence on the length of the land preceding the mark to be recorded.

[0041] FIG. 3 shows an embodiment of an optical recording device according to the invention. However, it will be apparent to those skilled in the art that embodiments of an optical recording device using more power levels can be realized by adding further outputs to the current source **61** and by extending the switch-unit **62**. Moreover, it will be apparent that a single output B, respectively D, of the current source **61** providing a varying current can, as an alternative, be replaced by several outputs, each providing a different current, while the setting means **64** select the appropriate output for setting the raised write power level and the intermediate power level, respectively, at any time.

1. An optical record carrier recording method for forming marks and lands by applying a radiation beam to a recording surface of an optical record carrier, the radiation beam for each mark to be recorded being set to at least one write power level capable of forming a mark during a write power irradiation period and being set for each land section between the marks, to at least one bottom power level incapable of forming a mark during a bottom power irradiation period, characterized in that

the radiation beam is set to at least one intermediate power level after the bottom power irradiation period and before the write power irradiation period, the intermediate power level being higher than the bottom power level and being set in accordance with a time length of the preceding bottom power irradiation period.

2. An optical record carrier recording method as claimed in claim 1 for recording marks having a time length of nT , where T represents the time length of one period of a reference clock in a data signal and n represents a prede-

terminated natural number, and where in the radiation beam is set to the intermediate power level during an intermediate power irradiation period, characterized in that

the time length of the intermediate power irradiation period is substantially equal to $1/4T$.

3. An optical record carrier recording method as claimed in claim 1 for recording marks having a time length of nT , where T represents the time length of one period of a reference clock in a data signal and n represents a predetermined natural number, characterized in that

an intermediate power level following a first bottom power irradiation period having a time length of $(n+1)T$ is set to be larger than or equal to an intermediate power level following a second bottom power irradiation period having a time length of nT .

4. An optical record carrier recording method as claimed in claim 3, characterized in that

an intermediate power level following a first bottom power irradiation period having a time length of $3T$ is set within a range of from 0.50 to 0.80 times the write power level, that

an intermediate power level following a second bottom power irradiation period having a time length of $4T$ is set within a range of from 0.75 to 0.95 times the write power level, and that

an intermediate power level following a third bottom power irradiation period having a time length of mT , where m represents a predetermined natural number larger than 4, is set so as to be substantially equal to the write power level.

5. An optical record carrier recording method as claimed in claim 1 for recording marks having a time length of nT , where T represents the time length of one period of a reference clock in a data signal and n represents a predetermined natural number,

wherein the radiation beam for each mark to be recorded, having a time length of wT , where w represents a predetermined natural number larger than 2, is set to a write power level capable of forming a mark, and

wherein the radiation beam for each mark to be recorded, having a time length of uT , where u represents a predetermined natural number lower than w , is set to a first raised write power level capable of forming a mark, the first raised write power level being higher than the write power level and being set in accordance with a time length of the mark to be recorded, and

wherein the radiation beam for each mark to be recorded, having a time length of vT , where v represents a predetermined natural number lower than w and higher than u , is set to the write power level during a first portion of a write power irradiation period and to a second raised write power level during a second portion of the write power irradiation period, the first portion preceding the second portion and the second raised write power level being higher than the write power level and being set in accordance with a time length of the mark to be recorded.

6. An optical record carrier recording method as claimed in claim 5,

wherein u equals **3** and w represents a predetermined natural number larger than **4**, and

wherein the first raised write power level is set, when recording a mark having a time length of uT , within a range of from 1.05 to 1.15 times the write power level, and

wherein the second raised write power level is set, when recording a mark having a time length of $4T$, within a range of from 1.00 to 1.08 times the write power level.

7. An optical record carrier recording method for forming marks and lands by applying a radiation beam to a recording surface of an optical record carrier, the marks having a time length of nT , where T represents the time length of one period of a reference clock in a data signal and n represents a predetermined natural number,

wherein the radiation beam for each mark to be recorded, having a time length of wT , where w represents a predetermined natural number larger than 2, is set to a write power level capable of forming a mark, and

wherein the radiation beam for each mark to be recorded, having a time length of uT , where u represents a predetermined natural number lower than w , is set to a first raised write power level capable of forming a mark, the first raised write power level being higher than the write power level and being set in accordance with a time length of the mark to be recorded, and

wherein the radiation beam for each mark to be recorded, having a time length of vT , where v represents a predetermined natural number lower than w and higher than u , is set to the write power level during a first portion of a write power irradiation period and set to a second raised write power level during a second portion of a write power irradiation period, the first portion preceding the second portion and the second raised write power level being higher than the write power level and being set in accordance with a time length of the mark to be recorded, and

wherein for each land section between the marks the radiation beam is set to at least one bottom power level incapable of forming a mark during a bottom power irradiation period.

8. An optical record carrier recording method as claimed in claim 7,

wherein u equals **3** and w represents a predetermined natural number larger than **4**, and

wherein the first raised write power level is set, when recording a mark having a time length of uT , within a range of from 1.05 to 1.15 times the write power level, and

wherein the second raised write power level is set, when recording a mark having a time length of $4T$, within a range of from 1.00 to 1.08 times the write power level.

9. An optical recording device for recording data in the form of marks and lands on a recording surface of an optical record carrier by irradiating the recording surface by means of a radiation beam, the device comprising a radiation source for providing the radiation beam and control means for controlling the power of the radiation beam such that it has at least one write power level capable of forming a mark during a write power irradiation period and that it has at least

one bottom power level incapable of forming a mark during a bottom power irradiation period, characterized in that

the control means are operative to control the power of the radiation beam such that it has at least one intermediate power level after the bottom power irradiation period and before the write power irradiation period, and that

the control means are operative to set the intermediate power level in accordance with a time length of the preceding bottom power irradiation period.

10. An optical recording device as claimed in claim 9 for recording marks having a time length of nT , where T represents the time length of one period of a reference clock in a data signal and n represents a predetermined natural number, characterized in that

the control means are operative to control the power of the radiation beam such that it has

an intermediate power level within a range of from 0.52 to 0.78 times the write power level when the intermediate power level follows a first bottom power irradiation period having a time length of $3T$, and such that it has an intermediate power level within a range of from 0.78 to 0.92 times the write power level when the intermediate power level follows a second bottom power irradiation period having a time length of $4T$, and such that it has

an intermediate power level substantially equal to the write power level when the intermediate power level follows a third bottom power irradiation period having a time length of mT , where m represents a predetermined natural number larger than 4.

11. An optical recording device for recording data in the form of marks and lands on a recording surface of an optical record carrier by irradiating the recording surface by means of a radiation beam, the marks having a time length of nT , where T represents the time length of one period of a reference clock in a data signal and n represents a predetermined natural number, the device comprising a radiation source for providing the radiation beam and control means for controlling the power of the radiation beam such that it has

a write power level capable of forming a mark when recording a mark having a time length of wT , where w represents a predetermined natural number larger than 2, and such that it has

a first raised write power level capable of forming a mark when recording a mark having a time length of uT , where u represents a predetermined natural number lower than w , the first raised write power level being higher than the write power level and being set in accordance with a time length of the mark to be recorded, and such that it has

a write power level during a first portion of a write power irradiation period and has a second raised write power level during a second portion of the write power irradiation period when recording a mark having a time length of vT , where v represents a predetermined natural number lower than w and higher than u , the first portion preceding the second portion and the second raised write power level being higher than the write power level and being set in accordance with a time length of the mark to be recorded, and such that it has

bottom power level incapable of forming a mark during a bottom power irradiation period between the marks.

12. An optical recording device as claimed in claim 11, wherein u equals **3** and w represents a predetermined natural number larger than **4**, and wherein the control means are operative to control the power of the radiation beam such that it has

a first raised write power level within a range of from 1.05 to 1.15 times the write power level when recording a mark having a time length of uT , and such that it has

a second raised write power level within a range of from 1.00 to 1.08 times the write power level when recording a mark having a time length of $4T$.

* * * * *