

(12) STANDARD PATENT APPLICATION (11) Application No. AU 2023208200 A1
(19) AUSTRALIAN PATENT OFFICE

(54) Title
MODIFIED RNA ENCODING VEGF-A POLYPEPTIDES, FORMULATIONS, AND USES RELATING THERETO

(51) International Patent Classification(s)
C07K 14/52 (2006.01) **A61K 47/02** (2006.01)
A61K 31/7088 (2006.01) **A61K 48/00** (2006.01)
A61K 39/00 (2006.01)

(21) Application No: **2023208200** (22) Date of Filing: **2023.07.28**

(43) Publication Date: **2023.08.17**

(43) Publication Journal Date: **2023.08.17**

(62) Divisional of:
2017277277

(71) Applicant(s)
ModernaTX, Inc.

(72) Inventor(s)
Parinder, Leif Karlsson;Fritsche Danielson, Regina Desirée;Hansson, Kenny Mikael;Gan, Li Ming;Clarke, Jonathan;Egnell, Ann-Charlotte Eva;Chien, Kenneth Randall

(74) Agent / Attorney
PHILLIPS ORMONDE FITZPATRICK, PO Box 323, COLLINS STREET WEST, VIC, 8007, AU

2023208200 28 Jul 2023

ABSTRACT

The disclosure relates to modified RNA molecules encoding VEGF-A polypeptides and formulations comprising the modified RNA. Aspects of the disclosure further relate to preparations and uses of formulations comprising the modified RNA in treating subjects suffering from diseases responsive to VEGF-A therapy.

2023208200 28 Jul 2023

TITLE

Modified RNA Encoding VEGF-A Polypeptides, Formulations, and Uses Relating Thereto

The present application is a divisional of Australian patent application 2017277277, the entire contents of which are incorporated herein by this cross-reference.

1. FIELD

[001] The disclosure relates to modified RNA molecules encoding VEGF-A polypeptides and formulations comprising the modified RNA. Aspects of the disclosure further relate to preparations and uses of formulations comprising the modified RNA in treating subjects suffering from diseases responsive to VEGF-A therapy.

2. BACKGROUND

[002] Vascular endothelial growth factor A (VEGF-A) pathways play a central role in the control of cardiovascular physiological function in general, and arteriogenesis in particular. VEGF-A's roles include activation of nitric oxide (NO) signaling, vascular permeability, tumor angiogenesis, arteriogenesis, endothelial replication, and cell fate switch for multipotent cardiovascular progenitors. While inhibition of VEGF-A pathways via both small molecules and antibodies has become the standard of care in selected forms of cancer and macular degeneration, it has remained challenging to unlock the potential of augmenting VEGF-A pathways for potential therapeutic effects that include relaxing smooth muscle, promoting new vessel formation, and potentially reversing the defects in vascular response associated with diabetic vascular complications.

[003] As such, a diverse number of methods have been attempted to allow clinically tractable approaches to control the spatial and temporal expression of VEGF-A in target tissues. However, each of the approaches has significant drawbacks: systemic VEGF-A protein approaches can result in significant hypotension and VEGF-A is rapidly

2023208200 28 Jul 2023

degraded; viral encapsulated and naked VEGF-A DNA plasmids have limited temporal control of protein expression and the efficiency of *in vivo* expression can be highly variable and non-dose dependent; adenoviral vectors can activate the immune system; and naked RNA is labile, has low levels of transfection, and also can trigger immune activation. As a result, these limitations have restricted the applicability of VEGF-A as a therapeutic platform.

[004] In some previous studies, the *in vivo* use of therapeutic RNAs, *e.g.*, siRNAs, has been dependent on utilizing lipid-nanoparticles (LNPs) to protect the mRNA from degradation as well as for efficient transfection. Furthermore, attempts to reach therapeutic levels of RNAi therapy in organs other than liver have resulted in infusion related hypersensitivity reactions as well as hepatotoxicity, thus limiting their use for disease therapy in other organ systems (Rudin C. M. et al., Clin. Cancer Res., (2004) 10, 7244-7251). In addition, other variants of these LNPs have been used clinically for therapeutic uses in selected cases, but can cause dose-dependent tissue injury (Coelho T. et al., N Engl J Med, (2013) 369, 819-829). Examples of such dose-dependent toxicity effects of some lipid-based nucleic acid pharmaceutical formulations include infusion related reactions such as dyspnea, hypoxia, rigors, back pain, hypotension, and liver injury. Furthermore, while cationic lipids are typically included in lipid formulations of RNA therapeutics, *e.g.*, siRNA, to improve RNA encapsulation and stability, some such lipids may exhibit dose dependent toxicities, such as disruption of the integrity of a membrane structure, cell lysis and necrosis, and/or alteration of the expression of multiple genes in undesirable manner (Xue H.Y., Curr Pharm Des., (2015) 21(22):3140-7). At preclinical and clinical levels, dose dependent systemic toxicities of lipoplexes

2023208200 28 Jul 2023

have also been well-documented. Capture of lipoplexes by Kupffer cells in liver can trigger inflammatory responses, which may inflict damages to liver and result in elevated levels in major liver function indicators. Leukopenia and thrombocytopenia may also occur (Zhang J., *Adv Drug Deliv Rev.*, (2005) 57(5):689–698). Moreover, lipofectamine causes an immune/inflammatory response and cell death.

[005] Accordingly, to avoid the potential immunogenicity of RNA and the dose-dependent toxicities associated with some LNPs, there is a need for alternative, less toxic formulations of modified RNAs encoding VEGF-A polypeptides, to deliver the modified RNAs at therapeutically appropriate levels in treating subjects suffering from diseases responsive to VEGF-A therapy.

3. SUMMARY

[006] The disclosure relates to modified RNA molecules encoding VEGF-A polypeptides and formulations comprising the modified RNA. Also disclosed are the consequent benefits of VEGF-A modified RNA in these formulations for protein expression, producing therapeutics with less toxicity, and providing tools useful in treating subjects suffering from diseases responsive to VEGF-A therapy.

[007] Certain embodiments of the present disclosure are summarized in the following paragraphs. This list is only exemplary and not exhaustive of all of the embodiments provided by this disclosure.

[008] Embodiment 1. A composition comprising a modified RNA, preferably the modified RNA of SEQ ID NO: 1, encoding a VEGF-A polypeptide of SEQ ID NO: 2 and a buffer, preferably a citrate saline buffer, a phosphate-buffered saline (PBS) buffer,

2023208200 28 Jul 2023

or a tromethamine (THAM) buffer, wherein the buffer is substantially free of divalent cations.

[009] Embodiment 2. A formulation comprising a pharmaceutically acceptable amount of a modified RNA, preferably the modified RNA of SEQ ID NO: 1, encoding a VEGF-A polypeptide of SEQ ID NO: 2 and a buffer, preferably a citrate saline buffer, a phosphate-buffered saline (PBS) buffer, or a tromethamine (THAM) buffer, wherein the buffer is substantially free of divalent cations.

[010] Embodiment 3. The formulation of embodiment 2, wherein said buffer substantially free of divalent cations is a citrate saline buffer.

[011] Embodiment 4. The formulation of embodiment 3, wherein the citrate saline buffer is substantially free of calcium and magnesium.

[012] Embodiment 5. The formulation of embodiment 3, wherein the citrate saline buffer contains no calcium or magnesium.

[013] Embodiment 6. The formulation of embodiment 2, further comprising a pharmaceutically acceptable excipient.

[014] Embodiment 7. The formulation of embodiment 6, wherein the pharmaceutically acceptable excipient is chosen from a solvent, dispersion media, diluent, dispersion, suspension aid, surface active agent, isotonic agent, thickening or emulsifying agent, preservative, core-shell nanoparticles, polymer, peptide, protein, cell, hyaluronidase, and mixtures thereof.

[015] Embodiment 8. A method of treating a subject suffering from a disease responsive to VEGF-A therapy, comprising administering to the subject the composition

2023208200 28 Jul 2023

according to embodiment 1, and/or the formulation according to any one of embodiments 2-7.

[016] Embodiment 9. The method of embodiment 8, wherein the buffer that is substantially free of divalent cations in said composition or formulation is a citrate saline buffer.

[017] Embodiment 10. The method of embodiment 9, wherein the citrate saline buffer is substantially free of calcium and magnesium.

[018] Embodiment 11. The method of embodiment 9, wherein the citrate saline buffer contains no calcium or magnesium.

[019] Embodiment 12. The method of embodiment 8, wherein the formulation further comprises a pharmaceutically acceptable excipient.

[020] Embodiment 13. The method of embodiment 12, wherein the pharmaceutically acceptable excipient is chosen from a solvent, dispersion media, diluent, dispersion, suspension aid, surface active agent, isotonic agent, thickening or emulsifying agent, preservative, core-shell nanoparticles, polymer, peptide, protein, cell, hyaluronidase, and mixtures thereof.

[021] Embodiment 14. The method of embodiment 8, wherein the disease is chosen from heart failure with reduced or preserved ejection fraction, kidney disease, a disease involving skin grafting and tissue grafting, post-MI cardiac dysfunction, ischemic heart disease, a vascular injury from trauma or surgery, a skin ulcer including a diabetic ulcer, critical limb ischemia, pulmonary hypertension, and peripheral arterial disease.

[022] Embodiment 15. The method of embodiment 8, wherein the disease is heart failure with reduced or preserved ejection fraction.

2023208200 28 Jul 2023

[023] Embodiment 16. The method of embodiment 8, wherein the disease is post-MI cardiac dysfunction.

[024] Embodiment 17. The method of embodiment 8, wherein the disease is ischemic heart disease.

[025] Embodiment 18. The method of embodiment 8, wherein the disease is a vascular injury from trauma or surgery.

[026] Embodiment 19. The method of embodiment 8, wherein the disease is a skin ulcer including a diabetic ulcer.

[027] Embodiment 20. The method of embodiment 8, wherein the disease is critical limb ischemia.

[028] Embodiment 21. The method of embodiment 8, wherein the disease is pulmonary hypertension.

[029] Embodiment 22. The method of embodiment 8, wherein the disease is peripheral arterial disease.

[030] Embodiment 23. The method of embodiment 8, wherein the composition or formulation is administered to the subject via intramuscular, intradermal, subcutaneous, intracardiac, or epicardiac route, through a portal vein catheter, through a coronary sinus catheter, and/or by direct administration into the area to be treated.

[031] Embodiment 24. The method of embodiment 8, wherein the composition or formulation is administered to the subject intramuscularly.

[032] Embodiment 25. The method of embodiment 8, wherein the composition or formulation is administered to the subject intradermally.

2023208200 28 Jul 2023

[033] Embodiment 26. The method of embodiment 8, wherein the composition or formulation is administered to the subject subcutaneously.

[034] Embodiment 27. The method of embodiment 8, wherein the composition or formulation is administered to the subject intracardially or epicardially, preferably at a fixed-dosage in multiple administrations.

[035] Embodiment 28. The method of embodiment 8, wherein the composition or formulation is administered to the subject through a portal vein catheter, preferably at a fixed-dosage in multiple administrations.

[036] Embodiment 29. The method of embodiment 8, wherein the composition or formulation is administered to the subject through a coronary sinus catheter, preferably at a fixed-dosage in multiple administrations.

[037] Embodiment 30. The method of embodiment 8, wherein the composition or formulation is administered to the subject by direct administration into the area to be treated, preferably at a fixed-dosage in multiple administrations.

[038] Embodiment 31. The method of embodiment 8, wherein the composition or formulation comprises a concentration of the modified RNA of between 0.1 and 1 $\mu\text{g}/\mu\text{L}$, preferably formulated in citrate saline buffer.

[039] Embodiment 32. The method of embodiment 8, wherein the composition or formulation comprises a concentration of the modified RNA of between 1 and 10 $\mu\text{g}/\mu\text{L}$, preferably formulated in citrate saline buffer.

[040] Embodiment 33. The method of embodiment 8, wherein the composition or formulation comprises a concentration of the modified RNA of between 10 and 50 $\mu\text{g}/\mu\text{L}$, preferably formulated in citrate saline buffer.

2023208200 28 Jul 2023

[041] Embodiment 34. The method of embodiment 9, wherein the composition or formulation with citrate saline buffer is less toxic to the subject than a lipid-based composition or formulation.

[042] Embodiment 35. A method for modulating a physiological process in a mammalian cell, tissue, or subject comprising contacting said mammalian cell, tissue, or subject with the composition according to embodiment 1, and/or the formulation according to any one of embodiments 2-7.

[043] Embodiment 36. The method of embodiment 35, wherein the modulating is chosen from inducing angiogenesis, stimulating vascular cell proliferation, increasing proliferation and/or altering the fate of epicardial derived progenitor cells, upregulating endothelialization, inducing cardiac regeneration, increasing revascularization of tissue grafts for wound healing, improving vascular function, increasing tissue perfusion and new vessel formation, reducing scar tissue, and improving cardiac function.

[044] Embodiment 37. The method of embodiment 35, wherein the modulating comprises inducing angiogenesis.

[045] Embodiment 38. The method of embodiment 35, wherein the modulating comprises stimulating vascular cell proliferation.

[046] Embodiment 39. The method of embodiment 35, wherein the modulating comprises increasing proliferation and/or altering the fate of epicardial derived progenitor cells.

[047] Embodiment 40. The method of embodiment 35, wherein the modulating comprises upregulating endothelialization.

2023208200 28 Jul 2023

[048] Embodiment 41. The method of embodiment 35, wherein the modulating comprises inducing cardiac regeneration.

[049] Embodiment 42. The method of embodiment 35, wherein the modulating comprises increasing revascularization of tissue grafts for wound healing.

[050] Embodiment 43. The method of embodiment 35, wherein the modulating comprises improving vascular function.

[051] Embodiment 44. The method of embodiment 35, wherein the modulating comprises increasing tissue perfusion and new vessel formation.

[052] Embodiment 45. The method of embodiment 35, wherein the modulating comprises reducing scar tissue.

[053] Embodiment 46. The method of embodiment 35, wherein the modulating comprises improving cardiac function.

[054] Embodiment 47. The method of embodiment 35, wherein the buffer that is substantially free of divalent cations in said composition or formulation is a citrate saline buffer.

[055] Embodiment 48. The method of embodiment 47, wherein the citrate saline buffer is substantially free of calcium and magnesium.

[056] Embodiment 49. The method of embodiment 47, wherein the citrate saline buffer contains no calcium or magnesium.

[057] Embodiment 50. The method of embodiment 35, wherein the composition or formulation comprises a concentration of the modified RNA of between 0.1 and 1 $\mu\text{g}/\mu\text{L}$, preferably formulated in citrate saline buffer.

2023208200 28 Jul 2023

[058] Embodiment 51. The method of embodiment 35, wherein the composition or formulation comprises a concentration of the modified RNA of between 1 and 10 $\mu\text{g}/\mu\text{L}$, preferably formulated in citrate saline buffer.

[059] Embodiment 52. The method of embodiment 35, wherein the composition or formulation comprises a concentration of the modified RNA of between 10 and 50 $\mu\text{g}/\mu\text{L}$, preferably formulated in citrate saline buffer.

[060] Embodiment 53. A method for expressing VEGF-A in a mammalian cell or tissue, comprising contacting said mammalian cell or tissue with the composition according to embodiment 1, and/or the formulation according to any one of embodiments 2-7.

[061] Embodiment 54. The method of embodiment 53, wherein the buffer that is substantially free of divalent cations in said composition or formulation is a citrate saline buffer.

[062] Embodiment 55. The method of embodiment 54, wherein the citrate saline buffer is substantially free of calcium and magnesium.

[063] Embodiment 56. The method of embodiment 54, wherein the citrate saline buffer contains no calcium or magnesium.

[064] Embodiment 57. The method of embodiment 53, wherein the composition or formulation comprises a concentration of the modified RNA of between 0.1 and 1 $\mu\text{g}/\mu\text{L}$, preferably formulated in citrate saline buffer.

[065] Embodiment 58. The method of embodiment 53, wherein the composition or formulation comprises a concentration of the modified RNA of between 1 and 10 $\mu\text{g}/\mu\text{L}$, preferably formulated in citrate saline buffer.

2023208200 28 Jul 2023

[066] Embodiment 59. The method of embodiment 53, wherein the composition or formulation comprises a concentration of the modified RNA of between 10 and 50 $\mu\text{g}/\mu\text{L}$, preferably formulated in citrate saline buffer.

[067] Embodiment 60. A method of producing VEGF-A in a subject, comprising administering to said subject the composition according to embodiment 1, and/or the formulation according to any one of embodiments 2-7.

[068] Embodiment 61. The method of embodiment 60, wherein the buffer that is substantially free of divalent cations in said composition or formulation is a citrate saline buffer.

[069] Embodiment 62. The method of embodiment 61, wherein the citrate saline buffer is substantially free of calcium and magnesium.

[070] Embodiment 63. The method of embodiment 61, wherein the citrate saline buffer contains no calcium or magnesium.

[071] Embodiment 64. The method of embodiment 60, wherein the formulation further comprises a pharmaceutically acceptable excipient.

[072] Embodiment 65. The method of embodiment 64, wherein the pharmaceutically acceptable excipient is chosen from a solvent, dispersion media, diluent, dispersion, suspension aid, surface active agent, isotonic agent, thickening or emulsifying agent, preservative, core-shell nanoparticles, polymer, peptide, protein, cell, hyaluronidase, and mixtures thereof.

[073] Embodiment 66. The method of embodiment 60, wherein the subject is suffering from a disease responsive to VEGF-A therapy.

2023208200 28 Jul 2023

[074] Embodiment 67. The method of embodiment 66, wherein the disease is chosen from heart failure with reduced or preserved ejection fraction, kidney disease, a disease involving skin grafting and tissue grafting, post-MI cardiac dysfunction, ischemic heart disease, a vascular injury from trauma or surgery, a skin ulcer including a diabetic ulcer, critical limb ischemia, pulmonary hypertension, and peripheral arterial disease.

[075] Embodiment 68. The method of embodiment 66, wherein the disease is heart failure with reduced or preserved ejection fraction.

[076] Embodiment 69. The method of embodiment 66, wherein the disease is post-MI cardiac dysfunction.

[077] Embodiment 70. The method of embodiment 66, wherein the disease is ischemic heart disease.

[078] Embodiment 71. The method of embodiment 66, wherein the disease is a vascular injury from trauma or surgery.

[079] Embodiment 72. The method of embodiment 66, wherein the disease is a skin ulcer including a diabetic ulcer.

[080] Embodiment 73. The method of embodiment 66, wherein the disease is critical limb ischemia.

[081] Embodiment 74. The method of embodiment 66, wherein the disease is pulmonary hypertension.

[082] Embodiment 75. The method of embodiment 66, wherein the disease is peripheral arterial disease.

[083] Embodiment 76. The method of embodiment 60, wherein the composition or formulation is administered to the subject via intramuscular, intradermal,

subcutaneous, intracardiac, or epicardiac route, through a portal vein catheter, through a coronary sinus catheter, and/or by direct administration into the area to be treated.

[084] Embodiment 77. The method of embodiment 60, wherein the composition or formulation is administered to the subject intramuscularly.

[085] Embodiment 78. The method of embodiment 60, wherein the composition or formulation is administered to the subject intradermally.

[086] Embodiment 79. The method of embodiment 60, wherein the composition or formulation is administered to the subject subcutaneously.

[087] Embodiment 80. The method of embodiment 60, wherein the composition or formulation is administered to the subject intracardially or epicardially, preferably at a fixed-dosage in multiple administrations.

[088] Embodiment 81. The method of embodiment 60, wherein the composition or formulation is administered to the subject through a portal vein catheter, preferably at a fixed-dosage in multiple administrations.

[089] Embodiment 82. The method of embodiment 60, wherein the composition or formulation is administered to the subject through a coronary sinus catheter, preferably at a fixed-dosage in multiple administrations.

[090] Embodiment 83. The method of embodiment 60, wherein the composition or formulation is administered to the subject by direct administration into the area to be treated, preferably at a fixed-dosage in multiple administrations.

[091] Embodiment 84. The method of embodiment 60, wherein the composition or formulation comprises a concentration of the modified RNA of between 0.1 and 1 $\mu\text{g}/\mu\text{L}$, preferably formulated in citrate saline buffer.

2023208200 28 Jul 2023

[092] Embodiment 85. The method of embodiment 60, wherein the composition or formulation comprises a concentration of the modified RNA of between 1 and 10 $\mu\text{g}/\mu\text{L}$, preferably formulated in citrate saline buffer.

[093] Embodiment 86. The method of embodiment 60, wherein the composition or formulation comprises a concentration of the modified RNA of between 10 and 50 $\mu\text{g}/\mu\text{L}$, preferably formulated in citrate saline buffer.

[094] Embodiment 87. A method for preparing a composition or formulation, comprising combining a modified RNA, preferably the modified RNA of SEQ ID NO: 1, encoding a VEGF-A polypeptide of SEQ ID NO: 2 with a buffer, preferably a citrate saline buffer, a phosphate-buffered saline (PBS) buffer, or a tromethamine (THAM) buffer into the composition or formulation, wherein the buffer is substantially free of divalent cations, and wherein the composition or formulation is effective for treating a subject suffering from a disease responsive to VEGF-A therapy.

[095] Embodiment 88. The method of embodiment 87, wherein the citrate saline buffer is substantially free of calcium and magnesium.

[096] Embodiment 89. The method of embodiment 87, wherein the citrate saline buffer contains no calcium or magnesium.

[097] Embodiment 90. The method of embodiment 87, wherein the composition or formulation comprises a concentration of the modified RNA of between 0.1 and 1 $\mu\text{g}/\mu\text{L}$, preferably formulated in citrate saline buffer.

[098] Embodiment 91. The method of embodiment 87, wherein the composition or formulation comprises a concentration of the modified RNA of between 1 and 10 $\mu\text{g}/\mu\text{L}$, preferably formulated in citrate saline buffer.

2023208200 28 Jul 2023

[099] Embodiment 92. The method of embodiment 87, wherein the composition or formulation comprises a concentration of the modified RNA of between 10 and 50 $\mu\text{g}/\mu\text{L}$, preferably formulated in citrate saline buffer.

[0100] Embodiment 93. The method of embodiment 87, wherein the composition or formulation with citrate saline buffer is less toxic to the subject than a lipid-based composition or formulation.

[0101] Embodiment 94. A method of reducing toxicity of a VEGF-A treatment in a subject, comprising formulating a modified RNA, preferably the modified RNA of SEQ ID NO: 1, encoding a VEGF-A polypeptide of SEQ ID NO: 2 with a buffer, preferably a citrate saline buffer, a phosphate-buffered saline (PBS) buffer, or a tromethamine (THAM) buffer into a composition or formulation, wherein the buffer is substantially free of divalent cations.

[0102] Embodiment 95. The method of embodiment 94, wherein the citrate saline buffer is substantially free of calcium and magnesium.

[0103] Embodiment 96. The method of embodiment 94, wherein the citrate saline buffer contains no calcium or magnesium.

[0104] Embodiment 97. A nucleic acid sequence comprising an in vitro transcription template for the generation of a modified RNA, preferably the modified RNA of SEQ ID NO: 1, encoding a VEGF-A polypeptide of SEQ ID NO: 2.

[0105] Embodiment 98. A method for increasing wound healing in a mammalian tissue or a subject comprising contacting said mammalian tissue or subject with the composition according to embodiment 1, and/or the formulation according to any one of embodiments 2-7.

2023208200 28 Jul 2023

[0106] Embodiment 99. A method for inducing neovascularization in a mammalian tissue or a subject comprising contacting said mammalian tissue or subject with the composition according to embodiment 1, and/or the formulation according to any one of embodiments 2-7.

[0107] Embodiment 100. A method for inducing angiogenesis in a mammalian tissue or a subject comprising contacting said mammalian tissue or subject with the composition according to embodiment 1, and/or the formulation according to any one of embodiments 2-7.

[0108] Embodiment 101. A method for inducing vasodilation in a mammalian tissue or a subject comprising contacting said mammalian tissue or subject with the composition according to embodiment 1, and/or the formulation according to any one of embodiments 2-7.

[0109] Embodiment 102. A method for inducing blood flow upregulation in a mammalian tissue or a subject comprising contacting said mammalian tissue or subject with the composition according to embodiment 1, and/or the formulation according to any one of embodiments 2-7.

[0110] Embodiment 103. A method for increasing capillary and/or arteriole density in a mammalian tissue or a subject comprising contacting said mammalian tissue or subject with the composition according to embodiment 1, and/or the formulation according to any one of embodiments 2-7.

[0111] Embodiment 104. A method for attenuating fibrosis in a mammalian tissue or a subject comprising contacting said mammalian tissue or subject with the

composition according to embodiment 1, and/or the formulation according to any one of embodiments 2-7.

4. DESCRIPTION OF DRAWINGS

[0112] Those of skill in the art will understand that the drawings, described below, are for illustrative purposes only. The drawings are not intended to limit the scope of the present teachings in any way.

[0113] FIGs. 1A and 1B: The structure (FIG. 1A) and sequence (SEQ ID NO: 1, FIG. 1B) of the VEGF-A modified RNA used in the Examples.

[0114] FIGs. 2A, 2B, and 2C: Transfection of a higher dose of modified RNA resulted in the production of more VEGF-A protein in human aortic smooth muscle cells (FIG. 2A). A time course of VEGF-A protein production after transfection with modified RNA in human aortic smooth muscle cells (FIG. 2B). VEGF-A protein production in mouse cardiac fibroblasts (FIG. 2C, left panel) and pig endothelial cells (FIG. 2C, right panel) after transfection with modified RNA.

[0115] FIGs. 3A, 3B, and 3C: VEGF-A protein produced from VEGF-A modified RNA induced phosphorylation of VEGFR2 in human endothelial cells (FIG. 3A) and activation of downstream signaling pathways eNOS in human endothelial cells (FIG. 3B) and Akt in mouse cardiac fibroblasts (FIG. 3C).

[0116] FIGs. 4A, 4B, and 4C: VEGF-A protein produced from VEGF-A modified RNA affects several critical steps in the angiogenic process. VEGF-A protein produced by VEGF-A modified RNA increased proliferation (FIG. 4A) and migration (FIG. 4B) of cultured human endothelial cells. VEGF-A protein produced by VEGF-A

2023208200 28 Jul 2023

modified RNA increased angiogenic sprout formation in 3D culture with beads coated with endothelial cells (FIG. 4C).

[0117] FIGs. 5A, 5B, and 5C: Images of angiogenic sprout formation from beads coated with endothelial cells and treated with control media (FIG. 5A) or conditioned media with modified RNA-produced VEGF-A (FIG. 5B). Enlarged view of angiogenic sprout formation from beads coated with endothelial cells and treated with modified RNA-produced VEGF-A (FIG. 5C).

[0118] FIGs. 6A, 6B, and 6C: Comparison of X-gal staining indicative of β -galactosidase enzyme produced in mouse hearts following a 50 μ L intracardiac injection of citrate saline (FIG. 6A), LacZ modified RNA formulated in lipofectamine (100 μ g, FIG. 6B) or in citrate saline buffer (150 μ g, FIG. 6C).

[0119] FIG. 7: Assessment of luciferase protein produced in mouse hearts following intracardiac injection of firefly luciferase modified RNA formulated in Phosphate-Buffered Saline (PBS, n=3), Citrate Saline (C/S, n=6), or Tromethamine AKA 2-amino-2-(hydroxymethyl)-1,3-propanediol (THAM, n=3). PBS, C/S and THAM buffers (n=2/group) were used as negative control.

[0120] FIGs. 8A, 8B, 8C, and 8D: Cardiac levels of VEGF-A protein at different time points following intracardiac injection of 15 μ g (circles), 150 μ g (squares) or 1800 μ g (triangles) of citrate saline-formulated VEGF-A modified RNA in naïve rats (FIG. 8A). Comparison of left ventricular ejection fraction and infarct size (as % of left ventricular mass) in rats subjected to myocardial infarction and intracardially injected with citrate/saline or VEGF-A modified RNA (150 or 1800 μ g formulated in citrate/saline). Ejection fraction (FIG. 8B) and infarct size (FIG. 8C) were assessed by

2023208200 28 Jul 2023

cardiac magnetic resonance imaging 8 days after the induction of infarction and injection. Levels of cardiac troponin I (TnI) in venous blood drawn from rats one day after induction of myocardial infarction and intracardially injected with citrate/saline or VEGF-A modified RNA formulated in citrate/saline (FIG. 8D).

[0121] FIGs. 9A and 9B: Representative samples harvested from the left ventricular free wall in Göttingen mini pigs epicardially injected with LacZ modified RNA (100 μ g at 3 separate injection sites). The tissue was harvested 6 hours after the injection and X-gal stained for 18 hours. The left sample shows staining in tissue injected with LacZ modified RNA formulated in lipofectamine (FIG. 9A) and the right sample tissue injected with LacZ modified RNA formulated in citrate/saline (FIG. 9B), respectively.

[0122] FIG. 10: Human VEGF-A protein in pig left ventricular tissue samples 6 hours following epicardial injection of varying doses of VEGF-A modified RNA in the Göttingen mini pig.

[0123] FIGs. 11A, 11B, 11C, 11D, 11E, 11F, and 11G: LacZ and luciferase modified RNA cardiac transfection and translation in a citrate saline buffer. 75 μ g of LacZ modified RNA injected into the mouse heart with a citrate saline buffer. Production of β -galactosidase was found in approximately 10% of the left ventricle of the hearts (representative images in FIG. 11 A, FIG. 11C, and FIG. 11D). Enlarged view of X-gal staining showing production of β -galactosidase in the heart after injection of LacZ modified RNA (FIG. 11B). Luciferase modified RNA injected into heart. RNA in situ hybridization with luciferase probe revealed presence of luciferase modified RNA in the myocardium at the site of injection (FIG. 11E). Enlarged view of RNA in situ

2023208200 28 Jul 2023

hybridization with luciferase probe showing presence of luciferase modified RNA (FIG. 11F). Immunohistochemistry revealed luciferase protein expression in the myocardium at the site of injection after injection of luciferase modified RNA (FIG. 11G).

[0124] FIGs. 12A, 12B, and 12C: VEGF-A protein expression after modified RNA injection to the heart with citrate/saline buffer is saturable and has similar pharmacokinetics across multiple species. VEGF-A protein pharmacokinetics after single cardiac injections of VEGF-A modified RNA formulated in citrate saline buffer (NTB) vs lipofectamine (LNP) in the mouse over 72 hours (FIG. 12A). Cross-species comparison of VEGF-A protein levels following increasing dosing of VEGF-A modified RNA in citrate saline (FIG. 12B). Rat pharmacokinetics of VEGF-A protein produced by increasing doses of VEGF-A modified RNA. Area under the curve (AUC) measurements for VEGF-A protein produced at 72 hours (FIG. 12C).

[0125] FIGs. 13A and 13B: Assessment of human VEGF-A protein production following intracardiac injection of human VEGF-A modified RNA in the mouse, rat and pig. Magnitude and time profiles (0 to 72 hours in FIG. 13A; and 0 to 192 hours in FIG. 13B) of VEGF-A protein produced in the mouse (filled squares), rat (filled stars) and pig (filled circles) heart following an intracardiac injection of 100 μ g VEGF-A modified RNA formulated in citrate/saline. Shown are geometric means \pm SD.

[0126] FIG. 14: Effects of human VEGF-A modified RNA and recombinant human VEGF-A on left ventricular ejection fraction (EF) in mini pigs subjected to myocardial infarction. Serial assessments of EF were carried out before (BF) and after (AF) a permanent occlusion of the left anterior descending coronary artery. A separate group of pigs were subjected to a sham procedure without coronary occlusion (open

2023208200 28 Jul 2023

circles, n=5). Subsequent assessment of EF were then carried out at the time of study drug injection 7 days after the occlusion (7D AF) and once more 2 months later (2 MO AF). At 7D AF, the pigs were randomised to receive 20 epicardial injections (100 μ L each) of either citrate/saline (filled squares, n=8) or VEGF-A modified RNA at a total dose of 1 mg (filled circles, n=8) or 10 mg (filled triangles, n=8) or recombinant human VEGF-A protein formulated in self-assembling nanofibers (filled diamonds, n=5), respectively. *, P<0.05 vs the citrate/saline control group at 2 MO AF, **, P<0.01 vs the citrate/saline control group at 2 MO AF, †, P<0.001 comparing change from 7 D AF until 2 MO AF, ††, P<0.0001 comparing change from 7 D AF until 2 MO AF.

[0127] FIG. 15: Effects of human VEGF-A modified RNA and recombinant human VEGF-A on maximal left ventricular pressure development over time (dP/dt max) in mini pigs subjected to myocardial infarction. Mini pigs were subjected to a permanent occlusion of the left anterior descending coronary artery to induce myocardial infarction. A separate group of pigs were subjected to a sham procedure without coronary occlusion (open circles, n=5). Seven days later, infarcted pigs were randomised to a blinded epicardial injection of citrate/saline vehicle (2 mL, filled squares), 1 mg (filled circles) or 10 mg (filled triangles) VEGF-A modified RNA or recombinant human VEGF-A protein (200 ng) formulated in self-assembling nanofibers (filled diamonds). The dose/volume was administered as 20 separate injections (100 μ L each) at the peri-infarct area. Left ventricular function was measured invasively 2 months after the injection. Shown are individual data and means \pm SEM.

[0128] FIG. 16: Effects of human VEGF-A modified RNA and recombinant human VEGF-A on minimal left ventricular pressure development over time (dP/dt min)

2023208200 28 Jul 2023

in mini pigs subjected to myocardial infarction. Mini pigs were subjected to a permanent occlusion of the left anterior descending coronary artery to induce myocardial infarction. A separate group of pigs were subjected to a sham procedure without coronary occlusion (open circles, n=5). Seven days later, infarcted pigs were randomised to a blinded epicardial injection of citrate/saline vehicle (2 mL, filled squares), 1 mg (filled circles) or 10 mg (filled triangles) VEGF-A modified RNA or recombinant human VEGF-A protein (200 ng) formulated in self-assembling nanofibers (filled diamonds). The dose/volume was administered as 20 separate injections (100 μ L each) at the peri-infarct area. Left ventricular function was measured invasively 2 months after the injection. Shown are individual data and means \pm SEM.

[0129] FIG. 17: Effects of human VEGF-A modified RNA and recombinant human VEGF-A on systolic function (inotropy, ESPVR) in mini pigs subjected to myocardial infarction. Mini pigs were subjected to a permanent occlusion of the left anterior descending coronary artery to induce myocardial infarction. A separate group of pigs were subjected to a sham procedure without coronary occlusion (open circles, n=5). Seven days later, infarcted pigs were randomised to a blinded epicardial injection of citrate/saline vehicle (2 mL, filled squares), 1 mg (filled circles) or 10 mg (filled triangles) VEGF-A modified RNA or recombinant human VEGF-A protein (200 ng) formulated in self-assembling nanofibers (filled diamonds). The dose/volume was administered as 20 separate injections (100 μ L each) at the peri-infarct area. Left ventricular function was measured invasively 2 months after the injection. Shown are individual data and means \pm SEM.

2023208200 28 Jul 2023

[0130] FIG. 18: Effects of human VEGF-A modified RNA and recombinant human VEGF-A on diastolic function (compliance, EDPVR) in mini pigs subjected to myocardial infarction. Mini pigs were subjected to a permanent occlusion of the left anterior descending coronary artery to induce myocardial infarction. A separate group of pigs were subjected to a sham procedure without coronary occlusion (open circles, n=5). Seven days later, infarcted pigs were randomised to a blinded epicardial injection of citrate/saline vehicle (2 mL, filled squares), 1 mg (filled circles) or 10 mg (filled triangles) VEGF-A modified RNA or recombinant human VEGF-A protein (200 ng) formulated in self-assembling nanofibers (filled diamonds). The dose/volume was administered as 20 separate injections (100 μ L each) at the peri-infarct area. Left ventricular function was measured invasively 2 months after the injection. Shown are individual data and means \pm SEM.

[0131] FIG. 19: Effects of human VEGF-A modified RNA and recombinant human VEGF-A on preload recruitable stroke work (PRSW) in mini pigs subjected to myocardial infarction. Mini pigs were subjected to a permanent occlusion of the left anterior descending coronary artery to induce myocardial infarction. A separate group of pigs were subjected to a sham procedure without coronary occlusion (open circles, n=5). Seven days later, infarcted pigs were randomised to a blinded epicardial injection of citrate/saline vehicle (2 mL, filled squares), 1 mg (filled circles) or 10 mg (filled triangles) VEGF-A modified RNA or recombinant human VEGF-A protein (200 ng) formulated in self-assembling nanofibers (filled diamonds). The dose/volume was administered as 20 separate injections (100 μ L each) at the peri-infarct area. Left

ventricular function was measured invasively 2 months after the injection. Shown are individual data and means \pm SEM.

[0132] FIGs. 20A, 20B and 20C: Effects of human VEGF-A modified RNA and recombinant human VEGF-A on infarct size in mini pigs subjected to myocardial infarction. Infarct size presented as global left ventricular infarct size (slices 2, 3, 4 and 5, FIG. 20A), mid left ventricular infarct size (slices 3 and 4, FIG. 20B) and mid-most left ventricular infarct size (slice 4, panel FIG. 20C) in mini pigs epicardially injected with citrate/saline (filled squares) or 1 mg (filled circles) or 10 mg (filled triangles) VEGF-A modified RNA or recombinant human VEGF-A protein (200 ng) formulated in self-assembling nanofibers (filled diamonds). The injection was given 7 days after the induction of myocardial infarction through a permanent occlusion of the left anterior descending coronary artery. Infarct size was measured 2 months after the injection. Shown are means \pm SEM.

[0133] FIG. 21: Body masses of mice during Trial 1 in Example 14. The body mass of each mouse was recorded at each imaging time point. Data presented are means \pm SEM, black bar; vehicle single injected, hatched bar; vehicle double injected, grey bar; VEGF-A modified RNA single injected, lined bar; VEGF-A modified RNA double injected, *; $p < 0.05$ for double vs single injected vehicle.

[0134] FIG. 22: Fasted and fed blood glucose measurements of mice in Trial 1 in Example 14. At Day 0, blood glucose was measured after a four hour fasting period. At Day 18, fed blood glucose was measured. Data presented are means \pm SEM, black bar; vehicle single injected, hatched bar; vehicle double injected, grey bar; VEGF-A modified

RNA single injected, lined bar; VEGF-A modified RNA double injected, *; $p < 0.05$ for VEGF-A modified RNA single injected vs vehicle single injected.

[0135] FIG. 23: Wound healing curve for Trial 1 in Example 14. The average normalized open wound area of the median values from three observers are plotted against days post surgery. Data presented are means \pm SEM, * $p < 0.05$ for VEGF-A modified RNA double injection (open square) vs vehicle single (filled circle) and double (open circle) injected respectively at day 6 and VEGF-A modified RNA double injection vs. vehicle double injection at day 10, respectively. Filled square; VEGF-A modified RNA single injected.

[0136] FIG. 24: Cubic spline interpolation of wound healing curve from Trial 1 in Example 14. A cubic spline interpolation was constructed to approximate time to 25%, 50%, and 75% closure as evidenced by the horizontal dashed gray lines. Data presented are means of normalized open wound areas of the median values from three observers. ϕ ; $p < 0.05$ for VEGF-A modified RNA double injection (open square) vs vehicle single injection (filled circle) #; $p < 0.05$ for VEGF-A modified RNA double injection vs vehicle double injection (open circle). Filled square; VEGF-A modified RNA single injected.

[0137] FIG. 25: Percent wound healing between time points in Trial 1 in Example 14. The average percent of wound closure was calculated between each time point using normalized wound area data. Data presented are means \pm SEM; * $p < 0.05$ for higher average percent wound closure for VEGF-A modified RNA double injection (lined bar) vs vehicle double (hatched bar) and single injection (black bar) respectively for day 3 to 6 and for lower average wound closure for VEGF-A modified RNA single injection (grey bar) vs. vehicle double and single injection for day 10 to 13, respectively.

[0138] FIG. 26: Representative images of hematoxylin- and eosin-stained sections of wounds in Trial 1 in Example 14. A; vehicle single injected, B; vehicle double injected, C; VEGF-A modified RNA single injected, D; VEGF-A modified RNA double injected.

[0139] FIG. 27: Representative images of CD31 stained sections of wounds in Trial 1 in Example 14. Arrowheads indicate areas of strong CD31 staining. A) Single vehicle, B) Double vehicle, C) Single VEGF-A modified RNA, D) Double VEGF-A modified RNA.

[0140] FIG. 28: Quantification of CD31 staining in Trial 1 in Example 14. Panels A to D are representative acquired images and Panels E to H are representative thresholded images of CD31 positive staining (brown channel). A and E; Single vehicle, B and F; Double vehicle, C and G; single VEGF-A modified RNA, D and H; double VEGF-A modified RNA, I; Quantification of percent area of CD31 staining (area covered by black pixels). Black bar; vehicle single injected, hatched bar; vehicle double injected, grey bar; VEGF-A modified RNA single injected, lined bar; VEGF-A modified RNA double injected.

[0141] FIG. 29: Downstream VEGF signalling analysis with Western blot (Trial 1) in Example 14. Top panel; pAKT and AKT blots of Day 18 samples from mice receiving a single dose of vehicle on Day 0, double dose of vehicle on Days 0 and 3, single dose of VEGF-A modified RNA on Day 0, and double dose of VEGF-A modified RNA on Days 0 and 3. Bottom panel; Quantified ratio of pAKT/AKT shows no statistical difference between treatment groups. Left bar; single vehicle injection, left middle bar;

2023208200 28 Jul 2023

double vehicle injection, right middle bar; single VEGF-A modified RNA injection, right bar; double VEGF-A modified RNA injection.

[0142] FIG. 30: Western blot analysis of pVEGFR2, VEGFR2 and VEGF-A in harvested mouse wounds at Day 18 from Trial 1 in Example 14. Top panel; pVEGFR2, VEGFR2, and VEGFA blots of Day 18 samples from mice receiving a single dose of vehicle on Day 0, double dose of vehicle on Days 0 and 3, single dose of VEGF-A modified RNA on Day 0, and double dose of VEGF-A modified RNA on Days 0 and 3. Bottom panel; Quantified ratio of pVEGFR2/VEGFR2 show no statistical difference between treatment groups. Left bar; single vehicle injection, left middle bar; double vehicle injection, right middle bar; single VEGF-A modified RNA injection, right bar; double VEGF-A modified RNA injection.

[0143] FIG. 31: Body masses of mice during Trial 2 in Example 14. The body mass of each mouse was recorded at each imaging time point. Data presented are means \pm SEM. Left bar; vehicle double injected, right bar: VEGF-A modified RNA double injected.

[0144] FIG. 32: Fasted and fed blood glucose in mice in Trial 2 in Example 14. At Day 0, blood glucose was measured after a four-hour fasting period. At Day 18, fed blood glucose was measured. Data presented are means \pm SEM. Left bar; vehicle double injected, right bar: VEGF-A modified RNA double injected.

[0145] FIG. 33: Schematic of in vivo application of oxygen-sensitive nanoparticles. A) Application of nanoparticles within the full thickness skin wound. Upon excitation, the nanoparticles emit strong room temperature fluorescence (B) and strong oxygen-dependent phosphorescence (C). A ratiometric image is constructed of the

2023208200 28 Jul 2023

ratio between fluorescence and phosphorescence to report the relative level of oxygen within the wound bed (D).

[0146] FIG. 34: Ratiometric images of relative oxygenation levels within wound beds in Trial 2 in Example 14. Representative brightfield and ratiometric images for double vehicle (top half) and double VEGF-A modified RNA (bottom half) treated wounds for each time point. The wound border is outlined in black.

[0147] FIG. 35: Quantification of oxygenation via image analysis of fluorescence and phosphorescence from the oxygen-sensitive nanoparticles in the wound bed. The mean gray value of each raw fluorescence to phosphorescence image was calculated for the wound bed. Data presented are means \pm SEM, * $p < 0.05$ for mean Gray value for VEGF-A modified RNA double injection (right bar) vs vehicle double injection (left bar).

[0148] FIG. 36: Wound healing curve for Trial 2 in Example 14. The average normalized open wound area of the median values from three independent observers are plotted against days post surgery. Data presented are means \pm SEM, * $p < 0.05$ for lower open wound area for VEGF-A modified RNA double injection (open square) vs vehicle double injection (open circle), respectively at day 6. Area under the curve was for vehicle double injection 641.31 and for VEGF-A modified RNA double injection 604.35, respectively.

[0149] FIG. 37: Cubic spline interpolation of wound healing curve from Trial 2 in Example 14. A cubic spline interpolation was constructed to approximate time to 25%, 50%, and 75% closure as evidenced by the gray dashed line. Data presented are means of normalized open wound areas of the median values from three observers. #; $p < 0.05$ for

2023208200 28 Jul 2023

VEGF-A modified RNA double injection (open square) vs double vehicle injection (open circle).

[0150] FIG. 38: Percent wound healing between time points in Trial 2 in Example 14. The average percent of wound closure was calculated between each time point using normalized wound area data. Data presented are means \pm SEM; * p < 0.05 for higher average percent wound closure for VEGF-A modified RNA double injection (right bar) vs vehicle double injection (left bar) for day 3-6.

[0151] FIG. 39: Photoacoustic microscopy of vascular responses to high-dose VEGF-A modified RNA in the mouse ear. First row; vascular structure; second row; sO₂ (%); third row; blood flow speed (mm/s). Dashed circle; injection site. Arrows in row 3; vessels with significantly upregulated blood flow. Labels on top of first row indicate time from intradermal injection of VEGF-A modified RNA (100 μ g).

[0152] FIG. 40: Neovessel formation and angiogenesis in the mouse ear intradermally injected with a high-dose VEGF-A modified RNA. Zoomed-in images of neovessels (labelled by arrows, second row) and angiogenesis in the ear of mouse intradermally injected with 100 μ g VEGF-A modified RNA. Region zoomed in is indicated by dash square in the first row. Labels on top of first row indicate time from intradermal injection of VEGF-A modified RNA (100 μ g).

[0153] FIG. 41: Photoacoustic microscopy of vascular responses to low-dose VEGF-A modified RNA in the mouse ear. First row; vascular structure; second row; sO₂ (%); third row; blood flow speed (mm/s). Dashed circle; injection site. Labels on top of first row indicate time from intradermal injection of VEGF-A modified RNA (10 μ g).

2023208200 28 Jul 2023

[0154] FIG. 42: Photoacoustic microscopy of vascular responses to human recombinant VEGF-A protein in the mouse ear. First row; vascular structure; second row; sO₂ (%); third row; blood flow speed (mm/s). Dashed circle; injection site. Labels on top of first row indicate time from intradermal injection of the human recombinant VEGF-A protein (1 µg). Vessels with obvious flow upregulation are indicated with arrows in third row.

[0155] FIG. 43: Photoacoustic microscopy of vascular responses to citrate/saline in the mouse ear. First row; vascular structure; second row; sO₂ (%); third row; blood flow speed (mm/s). Dashed circle; injection site. Labels on top of first row indicate time from intradermal injection of citrate/saline (10 µL).

[0156] FIG. 44: Effects of VEGF-A modified RNA, human recombinant VEGF-A protein, and citrate/saline on vascular responses in the mouse ear. Quantitative analysis of the acute and long-term vascular responses (vessel diameter, left panel, and volumetric blood flow, right panel) induced by the intradermal injection of VEGF-A modified RNA (100 µg, filled squares), human recombinant VEGF-A protein (1 µg, filled triangles) or citrate/saline (10 µL, filled circles) in the mouse ear. Values shown are means±SD, n=3/group.

[0157] FIG. 45: Influence on microvascular flow and oxygen saturation following injection of VEGF-A modified RNA in the mouse ear. VEGF-A modified RNA (100 µg) was intradermally injected in the mouse ear. Microvascular flow (panel A) and oxygen saturation (panel B) were assessed before injection (baseline) and 7 days later.

2023208200 28 Jul 2023

[0158] FIG. 46: Influence on microvascular flow and oxygen saturation following injection of recombinant human VEGF-A protein in the mouse ear. Recombinant human VEGF-A protein (1 μ g) was intradermally injected in the mouse ear. Microvascular flow (panel A) and oxygen saturation (panel B) were assessed before injection (baseline) and 7 days later.

[0159] FIG. 47: Influence on microvascular flow and oxygen saturation following injection of citrate/saline vehicle in the mouse ear. Citrate/saline vehicle (10 μ L) was intradermally injected in the mouse ear. Microvascular flow (panel A) and oxygen saturation (panel B) were assessed before injection (baseline) and 7 days later.

[0160] FIG. 48A and FIG. 48B: The experimental design for Example 16 is illustrated in FIG. 48A. Placement of VEGF-A modified RNA injections for Example 16 is illustrated in FIG. 48B.

[0161] FIG. 49: Human VEGF-A concentrations in microdialysis eluates from rabbits intradermally injected with VEGF-A modified RNA. Concentrations of human VEGF-A in eluates from 100 kDa microdialysis probes intradermally inserted in the rabbit hind leg. Values presented are mean \pm SEM. Microdialysis was started at t=0 h and four id injections of VEGF-A modified RNA injections (50 μ g each) were given at t=1 h. Dotted line indicates Lower Limit of Quantification (LLOQ, 33.4 pg/mL). Two probes were inserted in each rabbit, n=4 rabbits.

[0162] FIG. 50A, FIG. 50B, and FIG. 50C: Effects on capillary density (FIG. 50A), arteriole density (FIG. 50B), and fibrosis (FIG. 50C) following intracardiac injection of human VEGF-A modified RNA in pigs subjected to myocardial infarction *in vivo*. Mini pigs were subjected to permanent ligation of the left anterior descending

2023208200 28 Jul 2023

coronary artery and 7 days later epicardially injected with VEGF-A modified RNA (1 mg, filled grey bar (n=8), or 10 mg, hatched bar (n=8)) or citrate/saline (filled black bar, n=8). A separate group of animals underwent a sham procedure (coronary artery not ligated and epicardial injections not given (open bar, n=5). Two months after the ligation, the animals were terminated and cardiac tissue harvested for assessment of capillary density (FIG. 50A) in the peri-infarct (border) zone. Shown are means±SEM. *; P<0.05 and ***; P<0.001 vs the citrate/saline-treated animals (one-way ANOVA and Dunnett's post test). In FIG. 50B, two months after the ligation, the animals were terminated and cardiac tissue harvested for assessment of arteriole density in the peri-infarct (border) zone. Shown are means±SEM. **; P<0.0 vs the citrate/saline -treated animals (one-way ANOVA and Dunnett's post test). In FIG. 50C, two months after the ligation, the animals were terminated and cardiac tissue harvested for assessment of fibrosis (collagen deposition) remote from the infarcted area. Shown are means±SEM. *; P<0.05 and **; P<0.01 vs the citrate/saline -treated animals (one-way ANOVA and Dunnett's post test).

[0163] FIG. 51: Time profile of human VEGF-A protein production after VEGF-A modified RNA transfection in human aortic smooth muscle cells (hAoSMC, open circles) and in human cardiomyocytes derived from induced pluripotent cells (hiPS-CM, filled triangles). Data shown are means±SEM.

[0164] FIG. 52A and FIG. 52B: FIG. 52A illustrates immunohistochemistry of Wilms tumor 1 transcription factor (Wt-1) as a marker of Epicardium-Derived Cells (EPDC) in the normal non-infarcted mouse heart (control) and in hearts subjected to permanent occlusion of the left anterior descending coronary artery for 3, 7 or 14 days before tissue harvesting. Arrows indicate Wt-1 expression. FIG. 52B illustrates scoring of

occurrence of Wt-1⁺ cells in the normal non-infarcted mouse heart (control) and in hearts subjected to permanent occlusion of the left anterior descending coronary artery for 3, 7 or 14 days before tissue harvesting. MI; Myocardial Infarction. *; P<0.05, ***; P<0.001 vs Control, n=3-5 within each study group.

5. DETAILED DESCRIPTION

[0165] All references referred to are incorporated herein by reference in their entireties.

[0166] Many modifications and other embodiments of the disclosures set forth herein will come to mind to one skilled in the art to which these disclosures pertain having the benefit of the teachings presented in the foregoing descriptions and the associated drawings. Therefore, it is to be understood that the disclosures are not to be limited to the specific embodiments disclosed and that modifications and other embodiments are intended to be included within the scope of the appended claims. Although specific terms are employed herein, they are used in a generic and descriptive sense only and not for purposes of limitation.

[0167] Units, prefixes and symbols may be denoted in their SI accepted form. Unless otherwise indicated, nucleic acids are written left to right in 5' to 3' orientation; amino acid sequences are written left to right in amino to carboxy orientation, respectively. Numeric ranges are inclusive of the numbers defining the range. Amino acids may be referred to herein by either their commonly known three letter symbols or by the one-letter symbols recommended by the IUPAC-IUB Biochemical Nomenclature Commission. Nucleotides, likewise, may be referred to by their commonly accepted

single-letter codes. The terms defined below are more fully defined by reference to the specification as a whole.

5.1. Definitions

[0168] Unless specifically defined otherwise, all technical and scientific terms used herein have the same meaning as commonly understood by one of ordinary skill in the art to which this disclosure belongs. Unless mentioned otherwise, the techniques employed or contemplated herein are standard methodologies well known to one of ordinary skill in the art. The practice of the present disclosure will employ, unless otherwise indicated, conventional techniques of microbiology, tissue culture, molecular biology, chemistry, biochemistry and recombinant DNA technology, which are within the skill of the art. The materials, methods and examples are illustrative only and not limiting. The following is presented by way of illustration and is not intended to limit the scope of the disclosure.

[0169] In some embodiments, the numerical parameters set forth in the specification (into which the claims are incorporated in their entirety) are approximations that can vary depending upon the desired properties sought to be obtained by a particular embodiment. In some embodiments, the numerical parameters should be construed in light of the number of reported significant digits and by applying ordinary rounding techniques. Notwithstanding that the numerical ranges and parameters setting forth the broad scope of some embodiments of the present disclosure are approximations, the numerical values set forth in the specific examples are reported as precisely as practicable. The numerical values presented in some embodiments of the present disclosure may contain certain errors necessarily resulting from the standard deviation

2023208200 28 Jul 2023

found in their respective testing measurements. The recitation of ranges of values herein is merely intended to serve as a shorthand method of referring individually to each separate value falling within the range. Unless otherwise indicated herein, each individual value is incorporated into the specification as if it were individually recited herein.

[0170] For convenience, certain terms employed in the entire application (including the specification, examples, and appended claims) are collected here. Unless defined otherwise, all technical and scientific terms used herein have the same meaning as commonly understood by one of ordinary skill in the art to which this disclosure belongs.

[0171] As used herein, the term “administering” refers to the placement of a pharmaceutical composition or a pharmaceutical formulation comprising at least one modified RNA, into a subject by a method or route that results in at least partial localization of the pharmaceutical composition or the pharmaceutical formulation, at a desired site or tissue location. In some embodiments, the pharmaceutical composition or the pharmaceutical formulation comprising modified RNA can be administered by any appropriate route that results in effective treatment in the subject, i.e. administration results in delivery to a desired location or tissue in the subject where at least a portion of the protein expressed by the modified RNA is located at a desired target tissue or target cell location.

[0172] Administration can be intramuscular, transarterial, intraperitoneal, intravenous, intraarterial, subcutaneous, intraventricular, intradermal, intracardiac, epicardiac, through a portal vein catheter, through a coronary sinus catheter, and/or direct administration into the area to be treated. Pharmaceutical compositions are specially

2023208200 28 Jul 2023

formulated for each route of administration resulting in administration-specific pharmaceutical formulations.

[0173] The term “composition” used herein is generally understood to mean a combination of at least two parts or elements that make up something. For example, a composition as used herein usually comprises at least a polynucleotide, primary construct or modified RNA according to the disclosure and a suitable carrier or excipient.

[0174] The terms “comprise,” “have” and “include” are open-ended linking verbs. Any forms or tenses of one or more of these verbs, such as “comprises,” “comprising,” “has,” “having,” “includes” and “including,” are also open-ended. For example, any method that “comprises,” “has” or “includes” one or more steps is not limited to possessing only those one or more steps and can also cover other unlisted steps. Similarly, any composition that “comprises,” “has” or “includes” one or more features is not limited to possessing only those one or more features and can cover other unlisted features. All methods described herein can be performed in any suitable order unless otherwise indicated herein or otherwise clearly contradicted by context. The use of any and all examples, or exemplary language (e.g. “such as”) provided with respect to certain embodiments herein is intended merely to better illuminate the present disclosure and does not pose a limitation on the scope of the present disclosure otherwise claimed. No language in the specification should be construed as indicating any non-claimed element as essential to the practice of the present disclosure.

[0175] The term “consisting essentially of” limits the scope of a claim to the specified materials or steps “and those that do not materially affect the basic and novel characteristic(s)” of the claimed invention. *In re Herz*, 537 F.2d 549, 551-52, 190 USPQ

2023208200 28 Jul 2023

461, 463 (CCPA 1976) (emphasis in original) (Prior art hydraulic fluid required a dispersant which appellants argued was excluded from claims limited to a functional fluid “consisting essentially of” certain components.

[0176] The term “consisting of” refers to compositions, methods, and respective components thereof as described herein, which are exclusive of any element not recited in that description of the embodiment.

[0177] The terms “disease” or “disorder” are used interchangeably herein, and refers to any alternation in state of the body or of some of the organs, interrupting or disturbing the performance of the functions and/or causing symptoms such as discomfort, dysfunction, distress, or even death to the person afflicted or those in contact with a person. A disease or disorder can also related to a distemper, ailing, ailment, malady, sickness, illness, complaint, indisposition, or affection.

[0178] As used herein, the term “disease responsive to VEGF-A therapy” refers to a disorder that shows improvement of one or more symptoms or clinical markers after administration of a pharmaceutical composition or a pharmaceutical formulation comprising VEGF-A protein or an agent capable of producing VEGF-A protein, such as the modified RNA disclosed herein. Alternatively, a disease is “responsive” to VEGF-A therapy if the progression of the disease is reduced or halted with the administration of a pharmaceutical composition or a pharmaceutical formulation comprising VEGF-A protein or an agent capable of producing VEGF-A protein. Beneficial or desired clinical results include, but are not limited to, alleviation of one or more symptom(s), diminishment of extent of disease, stabilized (i.e., not worsening) state of disease, delay

2023208200 28 Jul 2023

or slowing of disease progression, amelioration or palliation of the disease state, and remission (whether partial or total).

[0179] As used herein, the term “divalent cation” refers to an ionic species with a positive valence of 2. For example, a magnesium ion, Mg^{2+} , and a calcium ion, Ca^{2+} are divalent cations.

[0180] A “dosage form” is the physical form in which a drug (for example, a modified RNA) is produced and dispensed, such as a tablet (coated, delayed release, dispersible, etc.), a capsule, an ointment, or an injectable (powder, solution).

[0181] The phrase “drug product” means a finished dosage form, for example, tablet, capsule, solution, etc., that contains an active drug ingredient (for example, a modified RNA) generally, but not necessarily, in association with inactive ingredients.

[0182] The term “effective amount” as used herein refers to the amount of therapeutic agent (for example, a modified RNA), pharmaceutical composition, or pharmaceutical formulation, sufficient to reduce at least one or more symptom(s) of the disease or disorder, or to provide the desired effect. For example, it can be the amount that effects a therapeutically or prophylactically significant reduction in a symptom or clinical marker associated with a cardiac dysfunction or other disorder when administered to a typical subject who has a cardiovascular condition, or other disease or disorder.

[0183] As used herein, “expression” of a nucleic acid sequence refers to one or more of the following events: (1) production of an RNA template from a DNA sequence (e.g., by transcription); (2) processing of an RNA transcript (e.g., by splicing, editing, 5' cap formation, and/or 3' end processing); (3) translation of an RNA into a polypeptide or protein; and (4) post-translational modification of a polypeptide or protein.

2023208200 28 Jul 2023

[0184] The term “formulation” or “pharmaceutical formulation” as used herein refers to a type of composition that comprises a pharmaceutical mixture or solution containing an active pharmaceutical ingredient (for example, a modified RNA), together with pharmaceutically acceptable carriers/diluents/excipients suitable to be administered to a mammal (e.g., a human in need thereof) via a particular route of administration. For example, a “formulation” as used herein can be specifically formulated to include suitable delivery agents and/or other pharmaceutically acceptable carriers for administration via one or more of a number of routes, such as via intramuscular, intradermal, subcutaneous, or intracardiac route, through a portal vein catheter, through a coronary sinus catheter, and/or by direct administration into the area to be treated. A “formulation” can therefore be understood to be a composition specially formulated for a particular route of administration. Formulations can be the compositions present in a particular dosage form.

[0185] As used herein, the term “modified RNA” refers to RNA molecules containing one, two, or more than two nucleoside modifications comparing to adenosine (A) ((2*R*,3*R*,4*S*,5*R*)-2-(6-amino-9*H*-purin-9-yl)-5-(hydroxymethyl)oxolane-3,4-diol), guanosine (G) (2-Amino-9-[3,4-dihydroxy-5-(hydroxymethyl)oxolan-2-yl]-3*H*-purin-6-one), cytidine (C) (4-amino-1-[3,4-dihydroxy-5-(hydroxymethyl)tetrahydrofuran-2-yl]pyrimidin-2-one), and uridine (U) (1-[(3*R*,4*S*,5*R*)-3,4-dihydroxy-5-(hydroxymethyl)oxolan-2-yl]pyrimidine-2,4-dione), or compared to AMP, GMP, CMP, and UMP, in RNA molecules, or a portion thereof. Non-limiting examples of nucleoside modifications are provided elsewhere in this specification. Where the nucleotide sequence of a particular claimed RNA is otherwise identical to the sequence of a

2023208200 28 Jul 2023

naturally-existing RNA molecule, the modified RNA is understood to be an RNA molecule with at least one modification different from those existing in the natural counterpart. The difference can be either in the chemical change to the nucleoside/nucleotide or in the position of that change within the sequence. In one embodiment, the modified RNA is modified messenger RNA (or “modified mRNA”).

[0186] As used herein, the term “modulating a physiological process” refers to a regulation of diverse functions and physical or chemical operations of living organisms and their parts, such as cells or tissues. For example, for physiological processes where VEGF-A plays central roles, the modulation may include inducing angiogenesis, stimulating vascular cell proliferation, increasing proliferation and/or altering the fate of epicardial derived progenitor cells, upregulating endothelialization, inducing cardiac regeneration, increasing revascularization of tissue grafts for wound healing, improving vascular function, increasing tissue perfusion and new vessel formation, reducing scar tissue, increasing preload recruitable stroke work (PRSW), increasing maximal pressure development, increasing inotropic function, increasing left ventricle ejection fraction (LVEF), decreasing levels of biomarkers associated with cardiac dysfunction (e.g., NT-proBNP, BNP, hsTnT and hsTnI), reducing infarct size, reducing fibrosis of cardiac tissue and/or improving cardiac function.

[0187] As used herein, the term “nucleic acid,” in its broadest sense, includes any compound and/or substance that comprises a polymer of nucleotides linked via a phosphodiester bond. These polymers are often referred to as oligonucleotides or polynucleotides, depending on the size. The terms “polynucleotide sequence” and “nucleotide sequence” are also used interchangeably herein.

2023208200 28 Jul 2023

[0188] The phrase “pharmaceutically acceptable” is employed herein to refer to those compounds, materials, compositions, and/or dosage forms which are, within the scope of sound medical judgment, suitable for use in contact with the tissues of human beings and animals without excessive toxicity, irritation, allergic response, or other problem or complication, commensurate with a reasonable benefit/risk ratio. Drug-approval agencies (e.g., EMA, US-FDA) provide guidance and approve pharmaceutically acceptable compounds, materials, compositions, and/or dosage forms. Examples can be listed in Pharmacopeias.

[0189] The phrase “pharmaceutically acceptable excipient” is employed herein to refer to a pharmaceutically acceptable material chosen from a solvent, dispersion media, diluent, dispersion, suspension aid, surface active agent, isotonic agent, thickening or emulsifying agent, preservative, core-shell nanoparticles, polymer, peptide, protein, cell, hyaluronidase, and mixtures thereof. In some embodiments, the solvent is an aqueous solvent.

[0190] As used herein, “polypeptide” means a polymer of amino acid residues (natural or unnatural) linked together most often by peptide bonds. The term, as used herein, refers to proteins, polypeptides, and peptides of any size, structure, or function. A polypeptide may be a single molecule or may be a multi-molecular complex such as a dimer, trimer or tetramer. They may also comprise single chain or multichain polypeptides such as antibodies or insulin and may be associated or linked. Most commonly disulfide linkages are found in multichain polypeptides. The term polypeptide may also apply to amino acid polymers in which one or more amino acid residues are an artificial chemical analogue of a corresponding naturally occurring amino acid.

2023208200 28 Jul 2023

[0191] As used herein, “protein” is a polymer consisting essentially of any of the 20 amino acids. Although “polypeptide” is often used in reference to relatively large polypeptides, and “peptide” is often used in reference to small polypeptides, usage of these terms in the art overlaps and is varied. The terms “peptide(s)”, “protein(s)” and “polypeptide(s)” are sometime used interchangeably herein.

[0192] The term “recombinant,” as used herein, means that a protein is derived from a prokaryotic or eukaryotic expression system through the use of a nucleic acid that has been genetically manipulated by the introduction of a “heterologous nucleic acid” or the alteration of a native nucleic acid.

[0193] The term “statistically significant” or “significantly” refers to statistical significance. The term refers to statistical evidence that there is a difference. It can be defined as the probability of making a decision to reject the null hypothesis when the null hypothesis is actually true. The decision is often made using the p-value. Any other measure of significant significance that is well-known in the art can be used.

[0194] The terms “subject” and “individual” are used interchangeably herein, and refer to an animal, for example a human, to whom treatment, including prophylactic treatment, with methods and compositions described herein, is or are provided. For treatment of those conditions or disease states which are specific for a specific animal such as a human subject, the term “subject” refers to that specific animal.

[0195] The term “substantially free of” refers to a condition in which a composition or formulation has no significant amounts of specific elements. For example, a composition or formulation “substantially free of” divalent cations contains little or no divalent cations.

2023208200 28 Jul 2023

[0196] As used herein, a subject or individual who is “suffering from” a disease, disorder, and/or condition has been diagnosed with or displays one or more symptoms of a disease, disorder, and/or condition. In some embodiments, a subject may be at risk of suffering from a disease, disorder and/or condition.

[0197] The term “tissue” refers to a group or layer of similarly specialized cells which together perform certain special functions. The term “tissue-specific” refers to a source or defining characteristic of cells from a specific tissue.

[0198] As used herein, the terms “treat” or “treatment” or “treating” refers to therapeutic treatment, wherein the object is to prevent or slow the development of the disease, such as slow down the development of a cardiac disorder, or reducing at least one adverse effect or symptom of a vascular condition, disease or disorder, such as, any disorder characterized by insufficient or undesired cardiac function.

[0199] It should be understood that this disclosure is not limited to the particular methodology, protocols, and reagents, etc., described herein and as such can vary. The terminology used herein is for the purpose of describing particular embodiments only, and is not intended to limit the scope of the present disclosure, which is defined solely by the claims.

5.2. Modified RNA Encoding VEGF-A Polypeptides

[0200] It is of great interest in the fields of therapeutics, diagnostics, reagents and for biological assays to be able to deliver a nucleic acid, e.g., a ribonucleic acid (RNA) inside a cell, whether *in vitro*, *in vivo*, *in situ*, or *ex vivo*, such as to cause intracellular translation of the nucleic acid and production of an encoded polypeptide of interest.

2023208200 28 Jul 2023

[0201] Naturally occurring RNAs are synthesized from four basic ribonucleotides: ATP, CTP, UTP and GTP, but may contain post-transcriptionally modified nucleotides. Further, approximately one hundred different nucleoside modifications have been identified in RNA (Rozenski, J, Crain, P, and McCloskey, J., The RNA Modification Database: 1999 update, Nucl Acids Res, (1999) 27: 196-197).

[0202] According to the present disclosure, these RNAs are preferably modified as to avoid the deficiencies of other RNA molecules of the art (e.g., activating the innate immune response and rapid degradation upon administration). Hence, these polynucleotides are referred to as modified RNA. In some embodiments, the modified RNA avoids the innate immune response upon administration to a subject. In some embodiments, the half-life of the modified RNA is extended compared to an unmodified RNA.

[0203] In preferred embodiments, the RNA molecule is a messenger RNA (mRNA). As used herein, the term "messenger RNA" (mRNA) refers to any polynucleotide that encodes a polypeptide of interest and that is capable of being translated to produce the encoded polypeptide of interest *in vitro*, *in vivo*, *in situ* or *ex vivo*.

[0204] As depicted in FIG 1A, traditionally, the basic components of an mRNA molecule include at least a coding region, a 5' untranslated region (UTR), a 3' untranslated region (UTR), a 5' cap and a poly-(A) tail. Building on this wild type modular structure, the present disclosure expands the scope of functionality of traditional mRNA molecules by providing polynucleotides or primary RNA constructs which maintain a modular organization, but which comprise one or more structural and/or

2023208200 28 Jul 2023

chemical modifications or alterations that impart useful properties to the polynucleotide including, in some embodiments, the lack of a substantial induction of the innate immune response of a cell into which the polynucleotide is introduced.

[0205] The modified RNAs can include any useful modification relative to the standard RNA nucleotide chain, such as to the sugar, the nucleobase (e.g., one or more modifications of a nucleobase, such as by replacing or substituting an atom of a pyrimidine nucleobase with optionally substituted amino, optionally substituted thiol, optionally substituted alkyl (e.g., methyl or ethyl), or halo (e.g., chloro or fluoro), or the internucleoside linkage (e.g., one or more modification to the phosphodiester backbone). The modified RNAs can optionally include other agents (e.g., RNAi-inducing agents, RNAi agents, siRNA, shRNA, miRNA, antisense RNA, ribozymes, catalytic DNA, tRNA, RNA that induce triple helix formation, aptamers, vectors, etc.).

[0206] U.S. Patent Application Publication No. 2014/0073687 discloses exemplary modified RNAs with several useful modifications, for example, at least one or more modified nucleosides chosen from 5-methylcytidine (5mC), N6-methyladenosine (m6A), 3,2'-O-dimethyluridine (m4U), 2-thiouridine (s2U), 2' fluorouridine, pseudouridine, 2'-O-methyluridine (Um), 2' deoxy uridine (2' dU), 4-thiouridine (s4U), 5-methyluridine (m5U), 2'-O-methyladenosine (m6A), N6,2'-O-dimethyladenosine (m6Am), N6,N6,2'-O-trimethyladenosine (m62Am), 2'-O-methylcytidine (Cm), 7-methylguanosine (m7G), 2'-O-methylguanosine (Gm), N2,7-dimethylguanosine (m-2,7G), N2,N2,7-trimethylguanosine (m-2,2,7G). Additional modifications are described in U.S. Patent Application Publication No. 2015/0051268, filed on October 7, 2014 and U.S. Patent No. 9,061,059, filed on February 3, 2014. Accordingly, all of these

modifications are incorporated herein in their entirety by reference. Additional modifications are described herein.

[0207] As non-limiting examples, in some embodiments, a modified RNA can include, for example, at least one uridine monophosphate (UMP) that is modified to form N1-methyl-pseudo-UMP. In some embodiments, the N1-methyl-pseudo-UMP is present instead of UMP in a percentage of the UMPs in the sequence of 0.1%, 1%, 2%, 3%, 4%, 5%, 10%, 15%, 20%, 25%, 30%, 35%, 40%, 45%, 50%, 55%, 60%, 65%, 70%, 75%, 80%, 85%, 90%, 95%, 99.9%, and 100%. In some embodiments, all UMP have been replaced by N1-methyl-pseudo-UMP.

[0208] In some embodiments, a modified RNA can (further) include, for example, at least one cytidine monophosphate (CMP) that is modified to form methyl-CMP. In some embodiments, the methyl-CMP is present instead of CMP in a percentage of the CMPs in the sequence chosen from 0.1%, 1%, 2%, 3%, 4%, 5%, 10%, 15%, 20%, 25%, 30%, 35%, 40%, 45%, 50%, 55%, 60%, 65%, 70%, 75%, 80%, 85%, 90%, 95%, 99.9%, and 100%. In some embodiments, all CMP have been replaced by 5-methyl-CMP.

[0209] In some embodiments, a modified RNA can (further) include, for example, at least one adenosine monophosphate (AMP) that is modified to form N6-methyl-AMP. In some embodiments, the N6-methyl-AMP is present instead of AMP in a percentage of the AMPs in the sequence chosen from 0.1%, 1%, 2%, 3%, 4%, 5%, 10%, 15%, 20%, 25%, 30%, 35%, 40%, 45%, 50%, 55%, 60%, 65%, 70%, 75%, 80%, 85%, 90%, 95%, 99.9%, and 100%. In some embodiments, all AMP have been replaced by N6-methyl-AMP.

2023208200 28 Jul 2023

[0210] In some embodiments, a modified RNA can (further) include, for example, at least one guanosine monophosphate (GMP) that is modified to form 7-methyl-GMP. In some embodiments, the 7-methyl-GMP is present instead of GMP in a percentage of the GMPs in the sequence chosen from 0.1%, 1%, 2%, 3%, 4%, 5%, 10%, 15%, 20%, 25%, 30%, 35%, 40%, 45%, 50%, 55%, 60%, 65%, 70%, 75%, 80%, 85%, 90%, 95%, 99.9%, and 100%. In some embodiments, all GMP have been replaced by 7-methyl-GMP.

[0211] In some embodiments, a modified RNA can (further) include, for example, at least one or more modified nucleosides chosen from 5-methylcytidine (5mC), N6-methyladenosine (m6A), 3,2'-O-dimethyluridine (m4U), 2-thiouridine (s2U), 2' fluorouridine, pseudouridine, 2'-O-methyluridine (Um), 2' deoxy uridine (2' dU), 4-thiouridine (s4U), 5-methyluridine (m5U), 2'-O-methyladenosine (m6A), N6,2'-O-dimethyladenosine (m6Am), N6,N6,2'-O-trimethyladenosine (m62Am), 2'-O-methylcytidine (Cm), 7-methylguanosine (m7G), 2'-O-methylguanosine (Gm), N2,7-dimethylguanosine (m-2,7G), N2,N2,7-trimethylguanosine (m-2,2,7G), and N1-methyl-pseudouridine, or any combination thereof. Each possibility and combination represents a separate embodiment of the present disclosure.

[0212] In some embodiments, modified RNAs comprise a modification to 5' cap, such as a 5' diguanosine cap. In some embodiments, modified RNAs comprise a modification to a coding region. In some embodiments, modified RNAs comprise a modification to a 5' UTR. In some embodiments, modified RNAs comprise a modification to a 3' UTR. In some embodiments, modified RNAs comprise a modification to a poly-(A) tail. In some embodiments, modified RNAs comprise any

2023208200 28 Jul 2023

combination of modifications to a coding region, 5' cap, 5' UTR, 3' UTR, or poly-(A) tail. In some embodiments, a modified RNA can optionally be treated with an alkaline phosphatase.

[0213] In some embodiments, a modified RNA encodes a Vascular Endothelial Growth Factor (VEGF) polypeptide, any one of a large family of VEGF proteins that play a central role in the control of cardiovascular physiological function in general, and arteriogenesis in particular (Holmes D.I. et al., *Genome Biol.*, (2005)6(2):209). VEGF's roles also include activation of nitric oxide (NO) signaling, vascular permeability, developmental and post-natal angiogenesis, tumor angiogenesis, arteriogenesis, endothelial replication, and as cell fate switch for multipotent cardiovascular progenitors.

[0214] It will be appreciated by those of skill in the art that for any particular VEGF gene there may exist one or more variants or isoforms. Non-limiting examples of the VEGF-A polypeptides in accordance with the present disclosure are listed in Table 1. It will be appreciated by those of skill in the art that the sequences disclosed in the **Table 1** contain potential flanking regions. These are encoded in each nucleotide sequence either to the 5' (upstream) or 3' (downstream) of the open reading frame. The open reading frame is definitively and specifically disclosed by teaching the nucleotide reference sequence. It is also possible to further characterize the 5' and 3' flanking regions by utilizing one or more available databases or algorithms. Databases have annotated the features contained in the flanking regions of the NCBI sequences and these are available in the art.

Table 1: *Homo sapiens* VEGF-A mRNA isoforms.

Description	NM Ref.	NP Ref.
-------------	---------	---------

2023208200 28 Jul 2023

<i>Homo sapiens</i> vascular endothelial growth factor A (VEGF-A), transcript variant 1, mRNA	NM_001171623.1	NP_001165094.1
<i>Homo sapiens</i> vascular endothelial growth factor A (VEGF-A), transcript variant 1, mRNA	NM_001025366.2	NP_001020537.2
<i>Homo sapiens</i> vascular endothelial growth factor A (VEGF-A), transcript variant 2, mRNA	NM_001171624.1	NP_001165095.1
<i>Homo sapiens</i> vascular endothelial growth factor A (VEGF-A), transcript variant 2, mRNA	NM_003376.5	NP_003367.4
<i>Homo sapiens</i> vascular endothelial growth factor A (VEGF-A), transcript variant 3, mRNA	NM_001171625.1	NP_001165096.1
<i>Homo sapiens</i> vascular endothelial growth factor A (VEGF-A), transcript variant 3, mRNA	NM_001025367.2	NP_001020538.2
<i>Homo sapiens</i> vascular endothelial growth factor A (VEGF-A), transcript variant 4, mRNA	NM_001171626.1	NP_001165097.1
<i>Homo sapiens</i> vascular endothelial growth factor A (VEGF-A), transcript variant 4, mRNA	NM_001025368.2	NP_001020539.2
<i>Homo sapiens</i> vascular endothelial growth factor A (VEGF-A), transcript variant 4, mRNA	NM_001317010.1	NP_001303939.1
<i>Homo sapiens</i> vascular endothelial growth factor A (VEGF-A), transcript variant 5, mRNA	NM_001171627.1	NP_001165098.1

2023208200 28 Jul 2023

<i>Homo sapiens</i> vascular endothelial growth factor A (VEGF-A), transcript variant 5, mRNA	NM_001025369.2	NP_001020540.2
<i>Homo sapiens</i> vascular endothelial growth factor A (VEGF-A), transcript variant 6, mRNA	NM_001171628.1	NP_001165099.1
<i>Homo sapiens</i> vascular endothelial growth factor A (VEGF-A), transcript variant 6, mRNA	NM_001025370.2	NP_001020541.2
<i>Homo sapiens</i> vascular endothelial growth factor A (VEGF-A), transcript variant 7, mRNA	NM_001171629.1	NP_001165100.1
<i>Homo sapiens</i> vascular endothelial growth factor A (VEGF-A), transcript variant 7, mRNA	NM_001033756.2	NP_001028928.1
<i>Homo sapiens</i> vascular endothelial growth factor A (VEGF-A), transcript variant 8, mRNA	NM_001171630.1	NP_001165101.1
<i>Homo sapiens</i> vascular endothelial growth factor A (VEGF-A), transcript variant 8, mRNA	NM_001171622.1	NP_001165093.1
<i>Homo sapiens</i> vascular endothelial growth factor A (VEGF-A), transcript variant 9, mRNA	NM_001204385.1	NP_001191314.1
<i>Homo sapiens</i> vascular endothelial growth factor A (VEGF-A), transcript variant 9, mRNA	NM_001204384.1	NP_001191313.1
<i>Homo sapiens</i> vascular endothelial growth factor A (VEGF-A), transcript variant 10, mRNA	NM_001287044.1	NP_001273973.1

[0215] It will be appreciated by those of skill in the art that RNA molecules encoding a VEGF-A polypeptide, e.g., a human VEGF-A polypeptide, can be designed according to the VEGF-A mRNA isoforms listed in the **Table 1**. One of ordinary of skill in the art is generally familiar with the multiple isoforms of the remaining VEGF family members.

[0216] In one embodiment, the present disclosure provides for a modified RNA encoding a VEGF-A polypeptide (e.g., SEQ ID NO: 2). In some embodiments, a modified RNA encodes a VEGF-A polypeptide, wherein the modified RNA comprises SEQ ID NO: 1. In some embodiments, the modified RNA further comprises a 5' cap, a 5' UTR, a 3' UTR, a poly(A) tail, or any combination thereof. In some embodiments, the 5' cap, the 5' UTR, the 3' UTR, the poly(A) tail, or any combination thereof may include one or more modified nucleotides.

[0217] In some embodiments, a modified RNA encoding a VEGF-A polypeptide can have the structure as depicted in FIG. 1B, which is SEQ ID NO: 1.

[0218] In some embodiments, a modified RNA encodes a VEGF polypeptide, wherein the modified RNA comprises one or more modified UMP nucleotides within the nucleic acid sequence of SEQ ID NO: 1. In some embodiments, a modified RNA encoding a VEGF-A polypeptide can include, for example, at least one of the UMP is modified to form N1-methyl-pseudo-UMP. In some embodiments, the N1-methyl-pseudo-UMP is present instead of UMP in a percentage of the UMPs in the sequence chosen from 0.1%, 1%, 2%, 3%, 4%, 5%, 10%, 15%, 20%, 25%, 30%, 35%, 40%, 45%,

50%, 55%, 60%, 65%, 70%, 75%, 80%, 85%, 90%, 95%, 99.9%, and 100%. In some embodiments, all UMP have been replaced by N1-methyl-pseudo-UMP.

[0219] In some embodiments, a modified RNA encodes a VEGF polypeptide, wherein the modified RNA (further) comprises one or more CMP modified nucleotides within the nucleic acid sequence of SEQ ID NO: 1. In some embodiments, the modified RNA encoding a VEGF-A polypeptide can include, for example, at least one of the CMP is modified to form methyl-CMP. In some embodiments, the methyl-CMP is present instead of CMP in a percentage of the CMPs in the sequence chosen from 0.1%, 2%, 3%, 4%, 1%, 5%, 10%, 15%, 20%, 25%, 30%, 35%, 40%, 45%, 50%, 55%, 60%, 65%, 70%, 75%, 80%, 85%, 90%, 95%, 99.9%, and 100%. In some embodiments, all CMP have been replaced by 5-methyl-CMP.

[0220] In some embodiments, a modified RNA encodes a VEGF polypeptide, wherein the modified RNA (further) comprises one or more AMP modified nucleotides within the nucleic acid sequence of SEQ ID NO: 1. In some embodiments, the modified RNA encoding a VEGF-A polypeptide can include, for example, at least one of the AMP is modified to form N6-methyl-AMP. In some embodiments, the N6-methyl-AMP is present instead of AMP in a percentage of the AMPs in the sequence chosen from 0.1%, 1%, 2%, 3%, 4%, 5%, 10%, 15%, 20%, 25%, 30%, 35%, 40%, 45%, 50%, 55%, 60%, 65%, 70%, 75%, 80%, 85%, 90%, 95%, 99.9%, and 100%. In some embodiments, all AMP have been replaced by N6-methyl-AMP.

[0221] In some embodiments, a modified RNA encodes a VEGF polypeptide, wherein the modified RNA (further) comprises one or more modified GMP nucleotides within the nucleic acid sequence of SEQ ID NO: 1. In some embodiments, the modified

2023208200 28 Jul 2023

RNA can include, for example, at least one of the GMP is modified to form 7-methyl-GMP. In some embodiments, the 7-methyl-GMP is present instead of GMP in a percentage of the GMPs in the sequence chosen from 0.1%, 1%, 2%, 3%, 4%, 5%, 10%, 15%, 20%, 25%, 30%, 35%, 40%, 45%, 50%, 55%, 60%, 65%, 70%, 75%, 80%, 85%, 90%, 95%, 99.9%, and 100%. In some embodiments, all GMP have been replaced by 7-methyl-GMP.

[0222] In some embodiments, a modified RNA encodes a VEGF polypeptide, wherein the modified RNA (further) comprises one or more modified nucleotides within the nucleic acid sequence of SEQ ID NO: 1. In some embodiments, the modified RNA encoding a VEGF-A polypeptide can include, for example, at least one or more modified nucleosides chosen from 5-methylcytidine (5mC), N6-methyladenosine (m6A), 3,2'-O-dimethyluridine (m4U), 2-thiouridine (s2U), 2' fluorouridine, pseudouridine, 2'-O-methyluridine (Um), 2' deoxy uridine (2' dU), 4-thiouridine (s4U), 5-methyluridine (m5U), 2'-O-methyladenosine (m6A), N6,2'-O-dimethyladenosine (m6Am), N6,N6,2'-O-trimethyladenosine (m62Am), 2'-O-methylcytidine (Cm), 7-methylguanosine (m7G), 2'-O-methylguanosine (Gm), N2,7-dimethylguanosine (m-2,7G), N2,N2,7-trimethylguanosine (m-2,2,7G), and N1-methyl-pseudouridine, or any combination thereof. Each possibility and combination represents a separate embodiment of the present disclosure.

5.3. Compositions Comprising Modified RNA

[0223] Some embodiments relate to compositions, including specific formulations, comprising disclosed modified RNAs. In some embodiments, a formulation comprises a pharmaceutically effective amount of one or more modified RNAs.

2023208200 28 Jul 2023

[0224] In some embodiments, a pharmaceutical composition can comprise at least one or more modified RNAs in a lipid-based complex, such as liposomes, lipoplexes, and lipid nanoparticles. In general, liposomes, lipoplexes, or lipid nanoparticles may be used to improve the efficacy of polynucleotide, primary construct, or modified RNA directed protein production as these formulations may be able to increase cell transfection by the polynucleotide, primary construct, or modified RNA; and/or increase the translation of encoded protein. One such example involves the use of lipid encapsulation to enable the effective systemic delivery of polyplex plasmid DNA (Heyes et al., *Mol Ther.* (2007) 15:713-720; herein incorporated by reference in its entirety). The liposomes, lipoplexes, or lipid nanoparticles may also be used to increase the stability of the polynucleotide, primary construct, or modified RNA.

[0225] Accordingly, in some embodiments, pharmaceutical compositions of modified RNAs include liposomes. Liposomes are artificially-prepared vesicles which may primarily be composed of a lipid bilayer and may be used as a delivery vehicle for the administration of nutrients and pharmaceutical formulations. Liposomes can be of different sizes such as, but not limited to, a multilamellar vesicle (MLV) which may be hundreds of nanometers in diameter and may contain a series of concentric bilayers separated by narrow aqueous compartments, a small unicellular vesicle (SUV) which may be smaller than 50 nm in diameter, and a large unilamellar vesicle (LUV) which may be between 50 and 500 nm in diameter. Liposome design may include, but is not limited to, opsonins or ligands in order to improve the attachment of liposomes to unhealthy tissue or to activate events such as, but not limited to, endocytosis. Liposomes may

contain a low or a high pH in order to improve the delivery of the pharmaceutical compositions.

[0226] In some embodiments, pharmaceutical compositions of modified RNA include a lipoplex, such as, without limitation, the ATUPLEX™ system, the DACC system, the DBTC system and other siRNA-lipoplex technology from Silence Therapeutics (London, United Kingdom), STEMFECT™ from STEMGENT® (Cambridge, Mass.), and polyethylenimine (PEI) or protamine-based targeted and non-targeted delivery of nucleic acids (Aleku et al. *Cancer Res.*, (2008) 68:9788-9798; Strumberg et al. *Int J Clin Pharmacol Ther*, (2012) 50:76-78; Santel et al., *Gene Ther*, (2006) 13:1222-1234; Santel et al., *Gene Ther*, (2006) 13:1360-1370; Gutbier et al., *Pulm Pharmacol. Ther.*, (2010) 23:334-344; Kaufmann et al. *Microvasc Res*, (2010) 80:286-293; Weide et al. *J Immuno Ther.*, (2009) 32:498-507; Weide et al. *J Immunother.*, (2008) 31:180-188; Pascolo *Expert Opin. Biol. Ther.* 4:1285-1294; Fotin-Mleczek et al., *J. Immunother*, (2011)34:1-15; Song et al., *Nature Biotechnol.*, (2005) 23:709-717; Peer et al., *Proc Natl Acad Sci USA.*, (2007) 6; 104:4095-4100; deFougerolles *Hum Gene Ther.*, (2008) 19:125-132; all of which are incorporated herein by reference in its entirety).

[0227] In some embodiments, pharmaceutical compositions of modified RNA include a solid lipid nanoparticle. A solid lipid nanoparticle (SLN) may be spherical with an average diameter between 10 to 1000 nm. SLN possess a solid lipid core matrix that can solubilize lipophilic molecules and may be stabilized with surfactants and/or emulsifiers. In a further embodiment, the lipid nanoparticle may be a self-assembly lipid-

2023208200 28 Jul 2023

polymer nanoparticle (see Zhang et al., ACS Nano, (2008), 2 (8), pp 1696-1702; herein incorporated by reference in its entirety).

[0228] Additional lipid-based compositions are discussed in U.S. Patent Application Publication No. 2015/0051268; herein incorporated by reference in its entirety. Accordingly, in some embodiments, pharmaceutical formulations of the modified RNA in accordance with this disclosure are formulated in lipid-based formulations as discussed in U.S. Patent Application Publication No. 2015/0051268.

[0229] In some embodiments of the present disclosure, pharmaceutical formulations of modified RNA do not include any lipid-based complex (such as liposomes, lipoplexes, or lipid nanoparticles) and are herein referred to as naked RNA formulations. WO 2012/103985 has suggested that naked RNA can penetrate cells only when it is formulated in the presence of divalent cations, preferably calcium. Furthermore, other studies have suggested and showed that calcium is needed for directing naked RNA molecules into animal tissues *in vivo* (Wolff J. A. et al., Science, (1999), 247, 1465–1468). Similarly, Probst et al. showed that injection of naked RNA *in vivo* strongly depends on the presence of calcium in the injection solution (Probst J. et al., Gene Ther, (2007) 14, 1175–1180). Accordingly, these studies dealing with delivery of naked RNA to cells and tissues have strongly suggested the need for calcium in the formulation.

[0230] Yet in some embodiments of the present disclosure, naked modified RNA is formulated with phosphate-buffered saline (PBS) buffer. For example, a modified RNA can be formulated with pH 7.4 PBS buffer substantially free of divalent cations. In some embodiments, a modified RNA can be formulated with pH 7.4 PBS

2023208200 28 Jul 2023

buffer substantially free of calcium or magnesium. In some embodiments, a modified RNA can be formulated with pH 7.4 PBS buffer containing no calcium or magnesium.

[0231] In some embodiments, naked modified RNA is formulated with citrate saline buffer. For example, a modified RNA can be formulated with pH 7.0 citrate saline buffer substantially free of divalent cations. In some embodiments, a modified RNA can be formulated with pH 7.0 citrate saline buffer substantially free of calcium or magnesium. In some embodiments, a modified RNA can be formulated with pH 7.0 citrate saline buffer containing no calcium or magnesium. For example, a modified RNA can be formulated with pH 7.0 citrate saline buffer containing 10 mmol/L citrate, 130 mmol/L sodium chloride in Hyclone water, wherein the citrate saline buffer does not contain calcium or magnesium.

[0232] In some embodiments, naked modified RNA is formulated with tromethamine (THAM) buffer. For example, a modified RNA can be formulated with pH 8.0 THAM buffer substantially free of divalent cations. In some embodiments, a modified RNA can be formulated with THAM buffer substantially free of calcium or magnesium. In some embodiments, a modified RNA can be formulated with pH 8.0 THAM buffer containing no calcium or magnesium. For example, a modified RNA can be formulated with pH 8.0 THAM buffer (tromethamine AKA 2-amino-2-(hydroxymethyl)-1,3-propanediol, 300 mmol/L Tris-HCl), wherein the THAM buffer does not contain calcium or magnesium.

[0233] In some embodiments, naked RNA pharmaceutical formulations may additionally comprise a pharmaceutically acceptable excipient, which, as used herein, includes, but is not limited to, any and all solvents, dispersion media, diluents, or other

2023208200 28 Jul 2023

liquid vehicles, dispersion or suspension aids, surface active agents, isotonic agents, thickening or emulsifying agents, preservatives, and the like, as suited to the particular dosage form desired. Excipients can also include, without limitation, polymers, core-shell nanoparticles, peptides, proteins, cells, hyaluronidase, nanoparticle mimics and combinations thereof. Various excipients for formulating pharmaceutical compositions and techniques for preparing the composition are known in the art (see Remington: The Science and Practice of Pharmacy, 22nd Edition, Edited by Allen, Loyd V., Jr, Pharmaceutical Press; incorporated herein by reference in its entirety). The use of a conventional excipient medium may be contemplated within the scope of the present disclosure, except insofar as any conventional excipient medium may be incompatible with a substance or its derivatives, such as by producing any undesirable biological effect or otherwise interacting in a deleterious manner with any other component(s) of the pharmaceutical composition.

[0234] In some embodiments, a naked RNA formulation comprises a pharmaceutically effective amount of one or more modified RNAs, wherein the formulation comprises a phosphate-buffered saline buffer and further comprises a pharmaceutically acceptable excipient. In some embodiments, the pharmaceutically acceptable excipient is chosen from a solvent, dispersion media, diluent, dispersion, suspension aid, surface active agent, isotonic agent, thickening or emulsifying agent, preservative, core-shell nanoparticles, polymer, peptide, protein, cell, hyaluronidase, and mixtures thereof. In some embodiments, the solvent is an aqueous solvent. In some embodiments, the solvent is a non-aqueous solvent.

2023208200 28 Jul 2023

[0235] In some embodiments, a naked RNA formulation comprises a pharmaceutically effective amount of one or more modified RNAs, wherein the formulation comprises a THAM buffer and further comprises a pharmaceutically acceptable excipient. In some embodiments, the pharmaceutically acceptable excipient is chosen from solvent, dispersion media, diluent, dispersion, suspension aid, surface active agent, isotonic agent, thickening or emulsifying agent, preservative, core-shell nanoparticles, polymer, peptide, protein, cell, hyaluronidase, and mixtures thereof. In some embodiments, the solvent is an aqueous solvent.

[0236] In some embodiments, a naked RNA formulation comprises a pharmaceutically effective amount of one or more modified RNAs, wherein the formulation comprises a citrate saline buffer and further comprises a pharmaceutically acceptable excipient. In some embodiments, the pharmaceutically acceptable excipient is chosen from a solvent, dispersion media, diluent, dispersion, suspension aid, surface active agent, isotonic agent, thickening or emulsifying agent, preservative, core-shell nanoparticles, polymer, peptide, protein, cell, hyaluronidase, and mixtures thereof. In some embodiments, the solvent is an aqueous solvent.

[0237] In certain embodiments, formulations comprising the modified RNA in accordance with the present disclosure are in a lipid-based complex (such as liposomes, lipoplexes, and lipid nanoparticles), phosphate-buffered saline buffer, THAM buffer, or citrate saline buffer at a concentration of between 0.1 and 1 $\mu\text{g}/\mu\text{L}$. In some embodiments, formulations comprising the modified RNA in accordance with the present disclosure are formulated in a lipid-based complex (such as liposomes, lipoplexes, and lipid nanoparticles), phosphate-buffered saline buffer, THAM buffer, or citrate saline

2023208200 28 Jul 2023

buffer at a concentration of between 1 and 10 $\mu\text{g}/\mu\text{L}$. In some embodiments, formulations comprising the modified RNA in accordance with the present disclosure are formulated in a lipid-based complex (such as liposomes, lipoplexes, and lipid nanoparticles), phosphate-buffered saline buffer, THAM buffer, or citrate saline buffer at a concentration of between 10 and 50 $\mu\text{g}/\mu\text{L}$.

[0238] In preferred embodiments, naked RNA formulations comprising the modified RNA in accordance with the present disclosure comprise a citrate saline buffer. In some embodiments, the formulation comprises a concentration of the modified RNA formulated in citrate saline buffer of between 0.1 and 1 $\mu\text{g}/\mu\text{L}$. In some embodiments, the formulation comprises a concentration of the modified RNA formulated in citrate saline buffer of between 1 and 10 $\mu\text{g}/\mu\text{L}$. In some embodiments, the formulation comprises a concentration of the modified RNA formulated in citrate saline buffer of between 10 and 50 $\mu\text{g}/\mu\text{L}$.

[0239] In some embodiments, a naked RNA formulation comprising a modified RNA encoding a VEGF-A polypeptide formulated in citrate saline buffer is less toxic to the subject than a lipid-based formulation.

5.4. Treating Subjects Suffering from Diseases Responsive to VEGF-A Therapy

[0240] Subjects with insufficient expression of VEGF-A can suffer from many vascular diseases including, without limitation, heart failure with reduced or preserved ejection fraction, kidney disease, a disease involving skin grafting and tissue grafting, post-MI cardiac dysfunction, ischemic heart disease, a vascular injury from trauma or surgery, a skin ulcer including a diabetic ulcer, critical limb ischemia, pulmonary

2023208200 28 Jul 2023

hypertension, and peripheral arterial disease. It is an aim of the present disclosure to treat subjects suffering from diseases responsive to VEGF-A therapy by direct administration of one or more modified RNA molecules encoding VEGF-A polypeptides. In some embodiments, naked VEGF-A RNA is administered to the subject in a citrate saline buffer without lipids and calcium.

[0241] In general, exogenous nucleic acids introduced into cells induce an innate immune response, resulting in interferon (IFN) production and cell death. However, modified RNAs have overcome at least some of these issues and are of great interest for therapeutics, diagnostics, reagents and for biological assays to deliver a nucleic acid, e.g., a ribonucleic acid (RNA) inside a cell, either *in vivo* or *ex vivo*, such as to cause intracellular translation of the nucleic acid and production of the encoded protein.

[0242] The modified RNAs and the proteins translated from the modified RNAs described herein can be used as therapeutic agents. For example, a modified RNA described herein can be administered to a subject, wherein the modified RNA is translated to produce a therapeutic protein of any VEGF family member, or a fragment thereof in the subject. Provided are methods for treatment of disease or conditions in humans and other mammals. All the formulations described herein for VEGF-A can be agreeably used with any other VEGF family member.

[0243] In some embodiments, compositions and particular formulations comprising one or more modified RNAs encoding VEGF-A polypeptides may be used for treatment of a disease such as heart failure with reduced or preserved ejection fraction, kidney disease, a disease involving skin grafting and tissue grafting, post-MI

cardiac dysfunction, ischemic heart disease, a vascular injury from trauma or surgery, a skin ulcer including a diabetic ulcer, healing wounds, such as lacerations, critical limb ischemia, pulmonary hypertension, and peripheral arterial disease.

[0244] In some embodiments, formulations comprising one or more modified RNAs encoding VEGF-A polypeptides may be used to treat heart failure with reduced or preserved ejection fraction. In some embodiments, formulations comprising one or more modified RNA encoding VEGF-A polypeptides may be used to treat post-MI cardiac dysfunction. In some embodiments, formulations comprising one or more modified RNA encoding VEGF-A polypeptides may be used to treat ischemic heart disease. In some embodiments, formulations comprising one or more modified RNA encoding VEGF-A polypeptides may be used to treat a vascular injury from trauma or surgery. In some embodiments, formulations comprising one or more modified RNA encoding VEGF-A polypeptides may be used to treat a skin ulcer including a diabetic ulcer. In some embodiments, the formulations comprising one or more modified RNA encoding VEGF-A polypeptides may be used in wound healing, for example, in healing lacerations. In some embodiments, formulations comprising one or more modified RNA encoding VEGF-A polypeptides may be used to critical limb ischemia. In some embodiments, formulations comprising one or more modified RNA encoding VEGF-A polypeptides may be used to treat pulmonary hypertension. In some embodiments, formulations comprising one or more modified RNA encoding VEGF-A polypeptides may be used to treat peripheral arterial disease. In some embodiments, formulations comprising one or more modified RNA encoding VEGF-A polypeptides may be used to treat kidney disease. In some embodiments, formulations comprising one or more modified RNA

2023208200 28 Jul 2023

encoding VEGF-A polypeptides may be used to treat a disease involving skin grafting and tissue grafting.

[0245] Other aspects of the disclosure relate to administration of the formulations comprising modified RNAs to subjects in need thereof. Administration of the formulation can be intramuscular, transarterial, intraperitoneal, intravenous, intraarterial, subcutaneous, intraventricular, intradermal, intracardiac, epicardiac, through a portal vein catheter, through a coronary sinus catheter, and/or direct administration into the area to be treated.

[0246] However, the present disclosure also encompasses the delivery of naked modified RNA molecules or modified RNA complexes, and/or pharmaceutical, prophylactic, or diagnostic formulations thereof, by any appropriate route taking into consideration likely advances in the sciences of drug delivery.

[0247] As non-limiting examples, in some embodiments, formulations in accordance with the present disclosure are administered to the subject via intramuscular, intradermal, subcutaneous, intracardiac or epicardiac route, through a portal vein catheter, through a coronary sinus catheter, and/or by direct administration into the area to be treated. In some embodiments, the formulation is administered to the subject intramuscularly. In some embodiments, the formulation is administered to the subject intradermally. In some embodiments, the formulation is administered to the subject subcutaneously.

[0248] In some embodiments, the formulation is administered to the subject intracardially, preferably at a fixed-dosage in multiple (e.g., two, three, four, five, six, seven, eight, nine, ten, eleven, twelve, thirteen, fourteen, fifteen, sixteen, seventeen,

2023208200 28 Jul 2023

eighteen, nineteen, twenty, or more) administrations. In some embodiments, the formulation is administered to the subject through a portal vein catheter, preferably at a fixed-dosage in multiple (e.g., two, three, four, five, six, seven, eight, nine, ten, eleven, twelve, thirteen, fourteen, fifteen, sixteen, seventeen, eighteen, nineteen, twenty, or more) administrations. In some embodiments, the formulation is administered to the subject through a coronary sinus catheter, preferably at a fixed-dosage in multiple (e.g., two, three, four, five, six, seven, eight, nine, ten, eleven, twelve, thirteen, fourteen, fifteen, sixteen, seventeen, eighteen, nineteen, twenty, or more) administrations. In some embodiments, the formulation is administered to the subject by direct administration into the area to be treated, preferably at a fixed-dosage in multiple (e.g., two, three, four, five, six, seven, eight, nine, ten, eleven, twelve, thirteen, fourteen, fifteen, sixteen, seventeen, eighteen, nineteen, twenty, or more) administrations. For example, the formulation is administered to the subject by direct injection to the damaged area during open heart surgery, preferably at a fixed-dosage in multiple (e.g., two, three, four, five, six, seven, eight, nine, ten, eleven, twelve, thirteen, fourteen, fifteen, sixteen, seventeen, eighteen, nineteen, twenty, or more) administrations. In some embodiments, the formulation is administered to the subject epicardially, preferably at a fixed-dosage in multiple (e.g., two, three, four, five, six, seven, eight, nine, ten, eleven, twelve, thirteen, fourteen, fifteen, sixteen, seventeen, eighteen, nineteen, twenty, or more) administrations. For example, in patients undergoing coronary artery by-pass grafting (CABG), the formulation is administered to the patient from the external side of the heart, preferably at a fixed-dosage in multiple (e.g., two, three, four, five, six, seven, eight, nine, ten, eleven, twelve, thirteen, fourteen, fifteen, sixteen, seventeen, eighteen, nineteen, twenty, or more)

2023208200 28 Jul 2023

administrations. In each of the embodiments in this paragraph, the “multiple administrations” can be separated from each other by short (1-5 mins), medium (6-30 minutes), or long (more than 30 minutes, hours, or even days) intervals of time.

[0249] The formulation may be administered to a subject using any amount of administration effective for treating a disease, disorder, and/or condition. The exact amount required will vary from subject to subject, depending on the species, age, and general condition of the subject, the severity of the disease, the particular formulation, its mode of administration, its mode of activity, and the like. It will be understood, however, that the total daily usage of the formulations may be decided by the attending physician within the scope of sound medical judgment. The specific pharmaceutically effective, dose level for any particular patient will depend upon a variety of factors including the disease being treated and the severity of the disease; the activity of the specific compound employed; the specific formulation employed; the age, body weight, general health, sex and diet of the patient; the time of administration, route of administration, and rate of excretion of the specific compound employed; the duration of the treatment; drugs (for example, a modified RNA) used in combination or coincidental with the specific compound employed; and like factors well known in the medical arts.

[0250] In certain embodiments, formulations in accordance with the present disclosure are administered to a subject, wherein the formulations comprise a lipid-based complex (such as liposomes, lipoplexes, and lipid nanoparticles). In other embodiments, naked modified RNA is administered in phosphate-buffered saline buffer, THAM buffer, or citrate saline buffer. In other embodiments, naked modified RNA is administered in the absence of divalent cations, including calcium. In preferred embodiments,

2023208200 28 Jul 2023

formulations for intracardiac or intradermal administration comprising the modified RNA are formulated in citrate saline buffer containing no calcium or magnesium. In some embodiments, the formulation comprises a concentration of the modified RNA formulated in citrate saline buffer of between 0.1 and 1 $\mu\text{g}/\mu\text{L}$. In some embodiments, the formulation comprises a concentration of the modified RNA formulated in citrate saline buffer of between 1 and 10 $\mu\text{g}/\mu\text{L}$. In some embodiments, the formulation comprises a concentration of the modified RNA formulated in citrate saline buffer of between 10 and 50 $\mu\text{g}/\mu\text{L}$.

[0251] In certain embodiments, formulations in accordance with the present disclosure may be administered at dosage levels sufficient to deliver from about 0.0001 mg/kg to about 100 mg/kg, from about 0.001 mg/kg to about 0.05 mg/kg, from about 0.005 mg/kg to about 0.05 mg/kg, from about 0.001 mg/kg to about 0.005 mg/kg, from about 0.05 mg/kg to about 0.5 mg/kg, from about 0.01 mg/kg to about 50 mg/kg, from about 0.1 mg/kg to about 40 mg/kg, from about 0.5 mg/kg to about 30 mg/kg, from about 0.01 mg/kg to about 10 mg/kg, from about 0.1 mg/kg to about 10 mg/kg, or from about 1 mg/kg to about 25 mg/kg, of modified RNA per subject body weight per day, one or more times a day, to obtain the desired therapeutic or prophylactic effect. The desired dosage may be delivered three times a day, two times a day, once a day, every other day, every third day, every week, every two weeks, every three weeks, every four weeks or once as a single dose, either in a bolus dose or in multiple administrations over a period of second, minutes or hours in a 24 hour period. In certain embodiments, the desired dosage may be delivered using multiple administrations (e.g., two, three, four, five, six,

seven, eight, nine, ten, eleven, twelve, thirteen, fourteen, fifteen, sixteen, seventeen, eighteen, nineteen, twenty, or more administrations).

[0252] In some embodiments, formulations in accordance with the present disclosure may be administered at fixed-dosage levels. For example, formulations in accordance with the present disclosure may be administered at fixed-dosage levels from about 0.1 mg to about 1 mg, either per administration or per total dose. In some embodiments, formulations in accordance with the present disclosure may be administered at fixed-dosage levels from about 1 mg to about 10 mg, either per administration or per total dose. In some embodiments, formulations in accordance with the present disclosure may be administered at fixed-dosage levels from about 10 mg to about 25 mg, either per administration or per total dose. In some embodiments, formulations in accordance with the present disclosure may be administered at fixed-dosage levels from about 25 mg to about 50 mg, either per administration or per total dose. In some embodiments, formulations in accordance with the present disclosure may be administered at fixed-dosage levels from about 50 mg to about 100 mg, either per administration or per total dose. In some embodiments, formulations in accordance with the present disclosure may be administered at fixed-dosage levels from about 0.1 to about 25 mg, either per administration or per total dose. In some embodiments, formulations in accordance with the present disclosure may be administered at a fixed-dosage, preferably in multiple (e.g., two, three, four, five, six, seven, eight, nine, ten, eleven, twelve, thirteen, fourteen, fifteen, sixteen, seventeen, eighteen, nineteen, twenty, or more) administrations. For example, in some embodiments, formulations in accordance with the present disclosure may be administered at 0.1 mg fixed-dosage, either per administration

2023208200 28 Jul 2023

or per total dose, preferably in multiple (e.g., two, three, four, five, six, seven, eight, nine, ten, eleven, twelve, thirteen, fourteen, fifteen, sixteen, seventeen, eighteen, nineteen, twenty, or more) administrations. In some embodiments, formulations in accordance with the present disclosure may be administered at 1 mg fixed-dosage, either per administration or per total dose, preferably in multiple (e.g., two, three, four, five, six, seven, eight, nine, ten, eleven, twelve, thirteen, fourteen, fifteen, sixteen, seventeen, eighteen, nineteen, twenty, or more) administrations. In some embodiments, formulations in accordance with the present disclosure may be administered at 10 mg fixed-dosage, either per administration or per total dose, preferably in multiple (e.g., two, three, four, five, six, seven, eight, nine, ten, eleven, twelve, thirteen, fourteen, fifteen, sixteen, seventeen, eighteen, nineteen, twenty, or more) administrations. In some embodiments, formulations in accordance with the present disclosure may be administered at 25 mg fixed-dosage, either per administration or per total dose, preferably in multiple (e.g., two, three, four, five, six, seven, eight, nine, ten, eleven, twelve, thirteen, fourteen, fifteen, sixteen, seventeen, eighteen, nineteen, twenty, or more) administrations. In some embodiments, formulations in accordance with the present disclosure may be administered at 50 mg fixed-dosage, either per administration or per total dose, preferably in multiple (e.g., two, three, four, five, six, seven, eight, nine, ten, eleven, twelve, thirteen, fourteen, fifteen, sixteen, seventeen, eighteen, nineteen, twenty, or more) administrations. In some embodiments, formulations in accordance with the present disclosure may be administered at 100 mg fixed-dosage, either per administration or per total dose, preferably in multiple (e.g., two, three, four, five, six, seven, eight, nine, ten,

eleven, twelve, thirteen, fourteen, fifteen, sixteen, seventeen, eighteen, nineteen, twenty, or more) administrations.

[0253] In some embodiments, formulations in accordance with the present disclosure are administered to a subject, wherein the formulation comprising a naked modified RNA encoding a VEGF-A polypeptide formulated in citrate saline buffer is less toxic to the subject than a lipid-based formulation. The assessments of toxicity due to RNA delivery in formulations in accordance with the present disclosure can be evaluated by methods well-known in the art. For example, cationic lipids are typically included in lipid formulations of RNA therapeutics to improve RNA encapsulation and stability. However, some cationic lipids may, in a dose-dependent manner, disrupt the integrity of a membrane structure, cause cell lysis and necrosis, and/or alter the expression of multiple genes in undesirable manner (Xue H.Y., *Curr Pharm Des.*, (2015) 21(22):3140-7; its entirety is incorporated herein by reference). Accordingly, examples of toxicity can be assessed by measuring the degree of cell lysis and necrosis, and/or alteration to the expression of multiple genes due to RNA delivery in formulations in accordance with the present disclosure. At preclinical and clinical levels, systemic dose-dependent toxicities of some lipoplexes have been well-documented. Capture of some lipoplexes by Kupffer cells in the liver can trigger inflammatory responses, which may inflict damages to liver and result in elevated levels in major liver function indicators. Leukopenia and thrombocytopenia may also occur (Zhang J., *Adv Drug Deliv Rev.*, (2005) 57(5):689-698; its entirety is incorporated herein by reference). Accordingly, examples of toxicity can be assessed by measuring the inflammatory responses due to RNA delivery in formulations in accordance with the present disclosure. In addition, examples of toxicity

can be assessed by measuring infusion related reactions such as dyspnea, hypoxia, rigors, back pain, hypotension, and liver injury.

[0254] A subject suffering from a vascular disease is “responsive” to the treatment if one or more symptoms or clinical markers are reduced. Alternatively, a treatment is working if the progression of a disease is reduced or halted. For example, heart failure (HF) occurs when the heart is weakened and is not filled with, or cannot pump, enough blood to meet the body's needs for blood and oxygen. Likewise, a patient with ischemic heart disease (IHD) has heart problems caused by narrowed heart arteries. When arteries are narrowed, less blood and oxygen reaches the heart muscle. As a consequence of microvascular dysfunction, loss of functional vessels, and/or loss of cardiac tissue, a patient usually develops cardiac dysfunction post-MI. Furthermore, vascular structures are most commonly injured by penetrating trauma or surgery. Diabetes impairs numerous components of wound healing, and a patient with diabetic wound healing generally has altered blood flow due to vascular dysfunction. Accordingly, a patient with skin ulcer including diabetic ulcers usually has decreased or delayed wound healing. Critical limb ischemia (CLI) is a severe obstruction of the arteries which markedly reduces blood flow to the extremities (hands, feet and legs) and has progressed to the point of severe pain and even skin ulcers, sores, or gangrene. Pulmonary hypertension (PH or PHTN) is an increase of blood pressure in the pulmonary artery, pulmonary vein, or pulmonary capillaries, together known as the lung vasculature, leading to shortness of breath, dizziness, fainting, leg swelling and other symptoms. Peripheral artery disease (PAD) is a narrowing of the peripheral arteries to the legs, stomach, arms, and head - most commonly in the arteries of the legs. These conditions

2023208200 28 Jul 2023

are routinely clinically diagnosed based on various physical examinations with confirmation by echocardiography, blood tests, magnetic resonance imaging (MRI) electrocardiography, and other suitable tests. For example, the diagnosis of significant vascular injury rests upon close physical examination and imaging tests. Accordingly, a treatment for any one of these conditions is working if the patient shows less severe symptoms by physical examinations and/or improvements in testing results from echocardiography, blood tests, MRI, electrocardiography, or any other suitable and/or routine tests.

[0255] In some embodiments, the subject suffering from a vascular disease has suffered a myocardial infarction. In some embodiments, the subject suffered a myocardial infarction within about one month prior to treatment with the formulations disclosed herein.

[0256] In some embodiments, the myocardial infarction triggers activation of Epicardium-derived cells (EPDC) over time. In some embodiments, the subject suffering a myocardial infarction is treated with the formulations disclosed herein several days after the myocardial infarction, preferably at the peak time of EPDC activation. In some embodiments, the subject suffering a myocardial infarction is treated with the formulations disclosed herein about 7 days after the myocardial infarction. In some embodiments, the subject suffering a myocardial infarction is treated with the formulations disclosed herein about 10 days after the myocardial infarction, 2 weeks after the myocardial infarction, 3 weeks after the myocardial infarction, or 6 weeks after the myocardial infarction.

2023208200 28 Jul 2023

[0257] In some embodiments, therapy with the compositions or formulations described herein comprises treating myocardial infarction with reduced ejection fraction. In other embodiments, therapy comprises treating heart failure with preserved ejection fraction. In some embodiments, the composition or formulation is injected at the border zone between healthy and infarcted tissue.

[0258] In some embodiments, the subject suffering from a vascular disease also suffers from coronary artery disease, high blood pressure, diabetes, atrial fibrillation, valvular heart disease, cardiomyopathy or an infection.

[0259] In some embodiments, the subject suffering from a vascular disease is suffering from left ventricular dysfunction. In some embodiments, the subject has a left ventricular ejection fraction (LVEF) of less than about 40%. In some embodiments, the subject has a LVEF of less than about 45%.

[0260] In some embodiments, the subject is suffering from heart failure with reduced or preserved ejection fraction. In some embodiments, the subject with heart failure with reduced or preserved ejection fraction is classified as stage II-IV of the New York Heart Association Functional Classification (NYHAFC) guidelines.

[0261] In some embodiments, the subject has elevated levels of one or more biomarkers indicative of heart failure with reduced or preserved ejection fraction (e.g., NT-proBNP, BNP, hsTnT or hsTnI). In some embodiments, the subject has elevated BNP (b-type Natriuretic Peptide) levels. In some embodiments, the subject has BNP levels of about 100 pg/mL. In some embodiments, the subject has BNP levels of between about 100-300 pg/mL. In some embodiments, the subject has BNP levels of about 300-600 pg/mL. In some embodiments, the subject has BNP levels of about 600 pg/mL. In

2023208200 28 Jul 2023

some embodiments, the subject BNP levels of between about 600-900 pg/mL. In some embodiments, the subject has elevated NT-proBNP (n-terminal pro b-type Natriuretic Peptide) levels. In some embodiments, the subject has NT-proBNP levels of about 450 pg/mL. In some embodiments, the subject is less than 50 years old and NT-proBNP levels of about 450 pg/mL. In some embodiments, the subject has NT-proBNP levels of about 900 pg/mL. In some embodiments, the subject is between about 50 and 75 years old and NT-proBNP levels of about 900 pg/mL. In some embodiments, the subject has NT-proBNP levels of at least 1800 pg/mL. In some embodiments, the subject is about 75 years old and NT-proBNP levels of about 1800 pg/mL. In some embodiments, the subject has elevated levels of hsTnT (high sensitivity Troponin T). In some embodiments, the subject has elevated levels of hsTnI (high sensitivity Troponin I).

[0262] In some embodiments, the subject has suffered a myocardial infarction within about a month prior to treatment with the formulations herein with an LVEF of less than about 45%.

[0263] In some embodiments, the subject is suffering from chronic ischemic heart failure with reduced or preserved ejection fraction with an LVEF of less than about 40%, an NT-proBNP level of at least about 600 pg/mL and is classified as stage II-IV on the NYHAFC guidelines.

[0264] Additionally, molecular measurements for vascular functions can be used to assess the improvements of the general pathophysiology. Examples of these measurements include enhanced nitric oxide (NO) availability, increased angiogenesis/arteriogenesis, and recruitment of stem cells to cardiac tissue. A patient

suffering from a vascular disease is therefore “responsive” to the treatment if the patient shows improved molecular functions in these measurements.

5.5. Modulating a physiological process in a mammalian cell, tissue, or subject

[0265] Another aspect of the present disclosure relates to the administration of a composition or a particular formulation comprising a modified RNA encoding a VEGF-A polypeptide for modulating a physiological process in a mammalian cell, tissue, or subject. In some embodiments, a method for modulating a physiological process in a mammalian cell, tissue, or subject comprises contacting the mammalian cell, tissue, or subject with a composition comprising the modified RNA in accordance with the present disclosure. As non-limiting examples, the modulation of a physiological process can include inducing angiogenesis, stimulating vascular cell proliferation, increasing proliferation and/or altering the fate of epicardial derived progenitor cells, upregulating endothelialization, inducing cardiac regeneration, increasing revascularization of tissue grafts for wound healing, improving vascular function, increasing tissue perfusion and new vessel formation, reducing scar tissue, increasing preload recruitable stroke work, increasing maximal pressure development, increasing inotropic function, increasing left ventricle ejection fraction (e.g., by between about 5 and 10%), decreasing levels of biomarkers associated with cardiac dysfunction (e.g., NT-proBNP, BNP, hsTnT and hsTnI), reducing infarct size, reducing fibrosis of cardiac tissue and/or improving cardiac function.

[0266] The term “contacting” or “contact” as used herein as in connection with contacting a cell, tissue, or subject with modified RNA as disclosed herein, includes

2023208200 28 Jul 2023

touching or extremely close proximity of modified RNA with the cell, tissue, or subject. Accordingly, in some embodiments, the phrase “contacting” refers to a method of exposure, which can be direct or indirect. In one method such contact comprises direct injection of the composition into the cell, tissue, or subject through any means well known in the art. In another embodiment, contacting also encompasses indirect contacting, such as via topical medium that surrounds the tissue, or via any route known in the art. Each possibility represents a separate embodiment of the present disclosure.

[0267] In some embodiments, a method for inducing angiogenesis in a mammalian cell, tissue, or subject comprises contacting the mammalian cell, tissue, or subject with a composition comprising the modified RNA in accordance with the present disclosure. In some embodiments, the composition is formulated in a phosphate-buffered saline buffer, THAM buffer, or citrate saline buffer. In preferred embodiments, compositions comprising the modified RNA comprise a citrate saline buffer. In some embodiments, the citrate saline buffer is substantially free of divalent cations, including calcium and magnesium. In some embodiments, the citrate saline buffer contains no calcium or magnesium. The effects of modified RNA on inducing angiogenesis can be evaluated by methods well-known in the art (see, e.g., Lopez J.J. et al., *Cardiovasc Res*, (1998) 40, 272-281; Galiano R.D. et al., *Am J Pathol.*, (2004) 164, 1935-1947; Lin Y.D. et al., *Sci Transl Med.*, (2012) 4(146):146ra109; Zangi L. et al., *Nat Biotechnol.*, (2013) 10, 898-907; all of which are incorporated herein by reference).

[0268] In some embodiments, a method for stimulating vascular cell proliferation in a mammalian cell, tissue, or subject comprises contacting the mammalian cell, tissue, or subject with a composition comprising the modified RNA in accordance

2023208200 28 Jul 2023

with the present disclosure. In some embodiments, the composition is formulated in a phosphate-buffered saline buffer, THAM buffer, or citrate saline buffer. In preferred embodiments, compositions comprising the modified RNA comprise a citrate saline buffer. In some embodiments, the citrate saline buffer is substantially free of divalent cations, including calcium and magnesium. In some embodiments, the citrate saline buffer contains no calcium or magnesium. The effects of modified RNA on stimulating vascular cell proliferation can be evaluated by methods well-known in the art (see, e.g., Galiano R.D. et al., *Am J Pathol*, (2004) 164, 1935-1947; its entirety is incorporated herein by reference).

[0269] In some embodiments, a method for increasing proliferation and/or altering the fate of epicardial derived progenitor cells in a mammalian cell, tissue, or subject comprises contacting the mammalian cell, tissue, or subject with a composition comprising the modified RNA in accordance with the present disclosure. In some embodiments, the composition is formulated in a phosphate-buffered saline buffer, THAM buffer, or citrate saline buffer. In preferred embodiments, compositions comprising the modified RNA comprise a citrate saline buffer. In some embodiments, the citrate saline buffer is substantially free of divalent cations, including calcium and magnesium. In some embodiments, the citrate saline buffer contains no calcium or magnesium. The effects of modified RNA on increasing proliferation and/or altering the fate of epicardial derived progenitor cells can be evaluated by methods well-known in the art (see, e.g., Zangi L. et al., *Nat Biotechnol.*, (2013) 10, 898-907; its entirety is incorporated herein by reference).

2023208200 28 Jul 2023

[0270] In some embodiments, a method for upregulating endothelialization in a mammalian cell, tissue, or subject comprises contacting the mammalian cell, tissue, or subject with a composition comprising the modified RNA in accordance with the present disclosure. In some embodiments, the composition is formulated in a phosphate-buffered saline buffer, THAM buffer, or citrate saline buffer. In preferred embodiments, compositions comprising the modified RNA comprise a citrate saline buffer. In some embodiments, the citrate saline buffer is substantially free of divalent cations, including calcium and magnesium. In some embodiments, the citrate saline buffer contains no calcium or magnesium. The effects of modified RNA on upregulating endothelialization can be evaluated by methods well-known in the art (see, e.g., Galiano R.D. et al., *Am J Pathol*, (2004) 164, 1935-1947; its entirety is incorporated herein by reference).

[0271] In some embodiments, a method for inducing cardiac regeneration in a mammalian cell, tissue, or subject comprises contacting the mammalian cell, tissue, or subject with a composition comprising the modified RNA in accordance with the present disclosure. In some embodiments, the composition is formulated in a phosphate-buffered saline buffer, THAM buffer, or citrate saline buffer. In preferred embodiments, compositions comprising the modified RNA comprise a citrate saline buffer. In some embodiments, the citrate saline buffer is substantially free of divalent cations, including calcium and magnesium. In some embodiments, the citrate saline buffer contains no calcium or magnesium. The effects of modified RNA on inducing cardiac regeneration can be evaluated by methods well-known in the art (see, e.g., Zangi L. et al., *Nat Biotechnol.*, (2013) 10, 898-907; Lin Y.D. et al., *Sci Transl Med.*, (2012) 4(146):146ra109; both of which are incorporated herein by reference).

2023208200 28 Jul 2023

[0272] In some embodiments, a method for increasing revascularization of tissue grafts for wound healing in a mammalian cell, tissue, or subject comprises contacting the mammalian cell, tissue, or subject with a composition comprising the modified RNA in accordance with the present disclosure. In some embodiments, the composition is formulated in a phosphate-buffered saline buffer, THAM buffer, or citrate saline buffer. In preferred embodiments, compositions comprising the modified RNA comprise a citrate saline buffer. In some embodiments, the citrate saline buffer is substantially free of divalent cations, including calcium and magnesium. In some embodiments, the citrate saline buffer contains no calcium or magnesium. The effects of modified RNA on increasing revascularization of tissue grafts for wound healing can be evaluated by methods well-known in the art (see, e.g., Tohyama H. et al., *Chang Gung Med J*, (2009) 32, 133-139; Chen J. et al., *Exp Ther Med*, (2012) 4, 430-434; both of which are incorporated herein by reference).

[0273] In some embodiments, a method for improving vascular function in a mammalian cell, tissue, or subject comprises contacting the mammalian cell, tissue, or subject with a composition comprising the modified RNA in accordance with the present disclosure. In some embodiments, the composition is formulated in a phosphate-buffered saline buffer, THAM buffer, or citrate saline buffer. In preferred embodiments, compositions comprising the modified RNA comprise a citrate saline buffer. In some embodiments, the citrate saline buffer is substantially free of divalent cations, including calcium and magnesium. In some embodiments, the citrate saline buffer contains no calcium or magnesium. The effects of modified RNA on improving vascular function can be evaluated by methods well-known in the art (see, e.g., Lopez J.J. et al., *Cardiovasc*

Res, (1998) 40, 272-281; Tio R.A. et al., Hum Gene Ther., (1999) 10, 2953-2960; Sato K. et al., J Am Coll Cardiol., (2001) 37, 616-23; all of which are incorporated herein by reference).

[0274] In some embodiments, a method for increasing tissue perfusion and new vessel formation in a mammalian cell, tissue, or subject comprises contacting the mammalian cell, tissue, or subject with a composition comprising the modified RNA in accordance with the present disclosure. In some embodiments, the composition is formulated in a phosphate-buffered saline buffer, THAM buffer, or citrate saline buffer. In preferred embodiments, compositions comprising the modified RNA comprise a citrate saline buffer. In some embodiments, the citrate saline buffer is substantially free of divalent cations, including calcium and magnesium. In some embodiments, the citrate saline buffer contains no calcium or magnesium. The effects of modified RNA on increasing tissue perfusion and new vessel formation can be evaluated by methods well-known in the art (see, e.g., Chiappini C., et al., Nat Mater., (2015) 14, 532-539; Lin Y.D. et al., Sci Transl Med., (2012) 4(146):146ra109; Zangi L. et al., Nat Biotechnol., (2013) 10, 898-907; all of which are incorporated herein by reference).

[0275] In some embodiments, a method for reducing scar tissue in a mammalian cell, tissue, or subject comprises contacting the mammalian cell, tissue, or subject with a composition comprising the modified RNA in accordance with the present disclosure. In some embodiments, the composition is formulated in a phosphate-buffered saline buffer, THAM buffer, or citrate saline buffer. In preferred embodiments, compositions comprising the modified RNA comprise a citrate saline buffer. In some embodiments, the citrate saline buffer is substantially free of divalent cations, including calcium and

2023208200 28 Jul 2023

magnesium. In some embodiments, the citrate saline buffer contains no calcium or magnesium. The effects of modified RNA on reducing scar tissue can be evaluated by methods well-known in the art (see, e.g., Rosano J.M. et al., *Cardiovasc Eng Technol.*, (2012) 3, 237–247; Galiano R.D. et al., *Am J Pathol.*, (2004) 164, 1935-1947; Lin Y.D. et al., *Sci Transl Med.*, (2012) 4(146):146ra109; Zangi L. et al., *Nat Biotechnol.* (2013) 10, 898-907; all of which are incorporated herein by reference).

[0276] In some embodiments, a method for improving cardiac function in a mammalian cell, tissue, or subject comprises contacting the mammalian cell, tissue, or subject with a composition comprising the modified RNA in accordance with the present disclosure. In some embodiments, the composition is formulated in a phosphate-buffered saline buffer, THAM buffer, or citrate saline buffer. In preferred embodiments, compositions comprising the modified RNA comprise a citrate saline buffer. In some embodiments, the citrate saline buffer is substantially free of divalent cations, including calcium and magnesium. In some embodiments, the citrate saline buffer contains no calcium or magnesium. The effects of modified RNA on improving cardiac function can be evaluated by methods well-known in the art (see, e.g., Rosano J.M. et al., *Cardiovasc Eng Technol.*, (2012) 3, 237–247; Lin Y.D. et al., *Sci Transl Med.*, (2012) 4(146):146ra109; Zangi L. et al., *Nat Biotechnol.*, (2013) 10, 898-907; all of which are incorporated herein by reference).

[0277] In some embodiments, a method for increasing preload recruitable stroke work (PRSW) in a mammalian cell, tissue, or subject comprises contacting the mammalian cell, tissue, or subject with a composition comprising the modified RNA in accordance with the present disclosure. In some embodiments, the composition is

2023208200 28 Jul 2023

formulated in a phosphate-buffered saline buffer, THAM buffer, or citrate saline buffer. In preferred embodiments, compositions comprising the modified RNA comprise a citrate saline buffer. In some embodiments, the citrate saline buffer is substantially free of divalent cations, including calcium and magnesium. In some embodiments, the citrate saline buffer contains no calcium or magnesium. The effects of modified RNA on increasing preload recruitable stroke work can be evaluated by methods well-known in the art (see *e.g.*, Fenely et al., JACC, (1992), 19(7):1522-30).

[0278] In some embodiments, a method for increasing maximal pressure development in a mammalian cell, tissue, or subject comprises contacting the mammalian cell, tissue, or subject with a composition comprising the modified RNA in accordance with the present disclosure. In some embodiments, the composition is formulated in a phosphate-buffered saline buffer, THAM buffer, or citrate saline buffer. In preferred embodiments, compositions comprising the modified RNA comprise a citrate saline buffer. In some embodiments, the citrate saline buffer is substantially free of divalent cations, including calcium and magnesium. In some embodiments, the citrate saline buffer contains no calcium or magnesium. The effects of modified RNA on increasing maximal pressure development can be evaluated by methods well-known in the art, such as left ventriculography, coronary angiography, echocardiography, MRI scans, CT scans, gated myocardial SPEC scans or gated myocardial PET scans.

[0279] In some embodiments, a method for increasing inotropic function in a mammalian cell, tissue, or subject comprises contacting the mammalian cell, tissue, or subject with a composition comprising the modified RNA in accordance with the present disclosure. In some embodiments, the composition is formulated in a phosphate-buffered

2023208200 28 Jul 2023

saline buffer, THAM buffer, or citrate saline buffer. In preferred embodiments, compositions comprising the modified RNA comprise a citrate saline buffer. In some embodiments, the citrate saline buffer is substantially free of divalent cations, including calcium and magnesium. In some embodiments, the citrate saline buffer contains no calcium or magnesium. The effects of modified RNA on increasing inotropic function can be evaluated by methods well-known in the art, such as left ventriculography, coronary angiography, echocardiography, MRI scans, CT scans, gated myocardial SPEC scans or gated myocardial PET scans.

[0280] In some embodiments, a method for increasing left ventricular ejection fraction (LVEF) in a mammalian cardiac cell or tissue, or subject comprises contacting the mammalian cell, tissue, or subject with a composition comprising the modified RNA in accordance with the present disclosure. In some embodiments, the composition is formulated in a phosphate-buffered saline buffer, THAM buffer, or citrate saline buffer. In preferred embodiments, compositions comprising the modified RNA comprise a citrate saline buffer. In some embodiments, the citrate saline buffer is substantially free of divalent cations, including calcium and magnesium. In some embodiments, the citrate saline buffer contains no calcium or magnesium. The effects of modified RNA on increasing left ventricular ejection fraction can be evaluated by methods well-known in the art, such as left ventriculography, coronary angiography, echocardiography, MRI scans, CT scans, gated myocardial SPEC scans or gated myocardial PET scans. In some embodiments, the LVEF is increased by between about 4% and 10%. In some embodiments, the LVEF is increased by between about 5% and 8%.

2023208200 28 Jul 2023

[0281] In some embodiments, a method for decreasing one or more biomarkers associated with cardiac dysfunction (e.g., NT-proBNP, BNP, hsTnT and hsTnI) in a mammalian cell, tissue, or subject comprises contacting the mammalian cell, tissue, or subject with a composition comprising the modified RNA in accordance with the present disclosure. In some embodiments, the composition is formulated in a phosphate-buffered saline buffer, THAM buffer, or citrate saline buffer. In preferred embodiments, compositions comprising the modified RNA comprise a citrate saline buffer. In some embodiments, the citrate saline buffer is substantially free of divalent cations, including calcium and magnesium. In some embodiments, the citrate saline buffer contains no calcium or magnesium.

[0282] In some embodiments, a method for reducing infarct size in a mammalian cell, tissue, or subject comprises contacting the mammalian cell, tissue, or subject with a composition comprising the modified RNA in accordance with the present disclosure. In some embodiments, the composition is formulated in a phosphate-buffered saline buffer, THAM buffer, or citrate saline buffer. In preferred embodiments, compositions comprising the modified RNA comprise a citrate saline buffer. In some embodiments, the citrate saline buffer is substantially free of divalent cations, including calcium and magnesium. In some embodiments, the citrate saline buffer contains no calcium or magnesium. In some embodiments, the infarct size is reduced. In some embodiments, the infarct is eliminated. The effects of modified RNA on infarct size can be evaluated by methods well-known in the art, such as left ventriculography, coronary angiography, echocardiography, MRI scans, CT scans, gated myocardial SPEC scans or gated myocardial PET scans.

2023208200 28 Jul 2023

[0283] In some embodiments, a method for reducing fibrosis in a mammalian cell, tissue, or subject comprises contacting the mammalian cell, tissue, or subject with a composition comprising the modified RNA in accordance with the present disclosure. In some embodiments, the composition is formulated in a phosphate-buffered saline buffer, THAM buffer, or citrate saline buffer. In preferred embodiments, compositions comprising the modified RNA comprise a citrate saline buffer. In some embodiments, the citrate saline buffer is substantially free of divalent cations, including calcium and magnesium. In some embodiments, the citrate saline buffer contains no calcium or magnesium. In some embodiments, the fibrosis is reduced. In some embodiments, the fibrosis is eliminated. The effects of modified RNA on fibrosis can be evaluated by methods well-known in the art, such as left ventriculography, coronary angiography, echocardiography, MRI scans, CT scans, gated myocardial SPEC scans or gated myocardial PET scans.

5.6. Expressing VEGF-A in a Mammalian Cell or Tissue

[0284] Another aspect of the present disclosure relates to the administration of a composition or a particular formulation comprising a modified RNA encoding a VEGF-A polypeptide for *in vivo*, *in vitro*, *in situ*, or *ex vivo* protein expression in a mammalian cell or tissue.

[0285] Some embodiments relate to a method for expressing VEGF-A in a mammalian cell or tissue, comprising contacting the mammalian cell or tissue *in vivo*, *in vitro*, or *ex vivo* with a composition comprising the modified RNA.

2023208200 28 Jul 2023

[0286] In some embodiments, a method for expressing VEGF-A in a mammalian cell or tissue comprises contacting the mammalian cell or tissue with a composition comprising the modified RNA in accordance with the present disclosure.

[0287] In some embodiments, a method for expressing VEGF-A in a mammalian cell or tissue comprises contacting the mammalian cell or tissue with a composition comprising the modified RNA in accordance with the present disclosure, wherein the composition is formulated in a phosphate-buffered saline buffer, THAM buffer, or citrate saline buffer. In preferred embodiments, compositions comprising the modified RNA comprise a citrate saline buffer. In some embodiments, the citrate saline buffer is substantially free of divalent cations, including calcium and magnesium. In some embodiments, the citrate saline buffer contains no calcium or magnesium.

[0288] In some embodiments, a method for expressing VEGF-A in a mammalian cell or tissue comprises contacting the mammalian cell or tissue with a composition comprising the modified RNA in accordance with the present disclosure, wherein the composition comprises a concentration of the modified RNA formulated in citrate saline buffer of between 0.1 and 1 $\mu\text{g}/\mu\text{L}$. In some embodiments, the composition comprises a concentration of the modified RNA formulated in citrate saline buffer of between 1 and 10 $\mu\text{g}/\mu\text{L}$. In some embodiments, the composition comprises a concentration of the modified RNA formulated in citrate saline buffer of between 10 and 50 $\mu\text{g}/\mu\text{L}$.

[0289] In some embodiments, a method for expressing VEGF-A in a mammalian cell or tissue comprises contacting the mammalian cell or tissue with a composition comprising the modified RNA in accordance with the present disclosure,

wherein the composition is formulated in a lipid-based complex (such as liposomes, lipoplexes, and lipid nanoparticles).

[0290] In some embodiments, a method for expressing VEGF-A in a mammalian cell or tissue comprises contacting the mammalian cell or tissue with a composition comprising the modified RNA formulated in citrate saline buffer, wherein the composition is less toxic to the subject than a lipid-based formulation.

5.7. Method of Producing VEGF-A in a Subject

[0291] Some embodiments relate to a method of producing VEGF-A in a subject, comprising administering to the subject a composition or a particular formulation comprising the modified RNA in accordance with this disclosure.

[0292] As non-limiting examples, in some embodiments, a method of producing VEGF-A in a subject comprises administering to the subject a formulation comprising the modified RNA in accordance with this disclosure. In some embodiments, formulations are formulated in citrate saline buffer. In some embodiments, the formulation further comprises a pharmaceutically acceptable excipient. In some embodiments, the formulation further comprises a pharmaceutically acceptable excipient chosen from a solvent, dispersion media, diluent, dispersion, suspension aid, surface active agent, isotonic agent, thickening or emulsifying agent, preservative, core-shell nanoparticles, polymer, peptide, protein, cell, hyaluronidase, and mixtures thereof. In some embodiments, the solvent is an aqueous solvent.

[0293] In some embodiments, the formulation further comprises a pharmaceutically acceptable excipient selected from lipid, lipidoid, liposome, lipid nanoparticle, lipoplex, and mixtures thereof.

2023208200 28 Jul 2023

[0294] In some embodiments, a method of producing VEGF-A in a subject comprises administering to the subject a formulation comprising the modified RNA in accordance with this disclosure, wherein the subject is suffering from a disease responsive to VEGF-A therapy. In some embodiments, the subject is suffering from a disease chosen from heart failure with reduced or preserved ejection fraction, kidney disease, a disease involving skin grafting and tissue grafting, post-MI cardiac dysfunction, ischemic heart disease, a vascular injury from trauma or surgery, a skin ulcer including a diabetic ulcer, critical limb ischemia, pulmonary hypertension, and peripheral arterial disease. In some embodiments, the disease is heart failure with reduced or preserved ejection fraction. In some embodiments, the disease is post-MI cardiac dysfunction. In some embodiments, the disease is ischemic heart disease. In some embodiments, the disease is a vascular injury from trauma or surgery. In some embodiments, the disease is a skin ulcer including a diabetic ulcer. In some embodiments, the disease is critical limb ischemia. In some embodiments, the disease is pulmonary hypertension. In some embodiments, the disease is peripheral arterial disease. In some embodiments, the disease is kidney disease. In some embodiments, the disease is a disease involving skin grafting and tissue grafting.

[0295] In some embodiments, a method of producing VEGF-A in a subject comprises administering to the subject a formulation comprising the modified RNA in accordance with this disclosure, wherein the formulation is administered to the subject via intramuscular, intradermal, subcutaneous, or intracardiac route, through a portal vein catheter, through a coronary sinus catheter, and/or by direct administration into the area to be treated. In some embodiments, the formulation is administered to the subject

2023208200 28 Jul 2023

intramuscularly. In some embodiments, the formulation is administered to the subject intradermally. In some embodiments, the formulation is administered to the subject subcutaneously. In some embodiments, the formulation is administered to the subject intracardially, preferably in multiple (e.g., two, three, four, five, six, seven, eight, nine, ten, eleven, twelve, thirteen, fourteen, fifteen, sixteen, seventeen, eighteen, nineteen, twenty, or more) administrations at a fixed-dosage. In some embodiments, the formulation is administered to the subject through a portal vein catheter. In some embodiments, the formulation is administered to the subject through a coronary sinus catheter. In some embodiments, the formulation is administered to the subject by direct administration into the area to be treated.

[0296] In some embodiments, a method of producing VEGF-A in a subject comprises administering to the subject a formulation comprising the modified RNA in accordance with this disclosure, wherein the formulation comprises a lipid-based complex (such as liposomes, lipoplexes, and lipid nanoparticles), phosphate-buffered saline buffer, THAM buffer, or citrate saline buffer. In preferred embodiments, formulations comprising the modified RNA are formulated in citrate saline buffer. In some embodiments, the citrate saline buffer is substantially free of calcium and magnesium. In some embodiments, the citrate saline buffer contains no calcium or magnesium.

[0297] In some embodiments, a method of producing VEGF-A in a subject comprises administering to the subject a formulation comprising the modified RNA in accordance with this disclosure, wherein the formulation comprises a concentration of the modified RNA formulated in citrate saline buffer of between 0.1 and 1 $\mu\text{g}/\mu\text{L}$. In some

2023208200 28 Jul 2023

embodiments, the formulation comprises a concentration of the modified RNA formulated in citrate saline buffer of between 1 and 10 $\mu\text{g}/\mu\text{L}$. In some embodiments, the formulation comprises a concentration of the modified RNA formulated in citrate saline buffer of between 10 and 50 $\mu\text{g}/\mu\text{L}$.

[0298] In some embodiments, a method of producing VEGF-A in a subject comprises administering to the subject a formulation comprising the modified RNA in accordance with this disclosure, wherein the formulation comprises a in citrate saline buffer and is less toxic to the subject than a lipid-based formulation.

5.8. Method for Preparing a Formulation

[0299] Some embodiments relate to a method for preparing a formulation, comprising combining the modified RNA in accordance with this disclosure with a lipid-based complex (such as liposomes, lipoplexes, and lipid nanoparticles), phosphate-buffered saline buffer, THAM buffer, or citrate saline buffer.

[0300] Some embodiments relate to a method for preparing a formulation, comprising combining the modified RNA with citrate saline buffer, wherein the formulation is effective for treating a subject suffering from a disease responsive to VEGF-A therapy; modulating a physiological process in mammalian cell, tissue, or subject; expressing VEGF-A in a mammalian cell or tissue; and/or producing VEGF-A in a subject.

[0301] In some embodiments, a method for preparing a formulation comprises combining the modified RNA in accordance with this disclosure with citrate saline buffer, wherein the formulation comprises a concentration of the modified RNA formulated in citrate saline buffer of between 0.1 and 1 $\mu\text{g}/\mu\text{L}$. In some embodiments, the

2023208200 28 Jul 2023

formulation comprises a concentration of the modified RNA formulated in citrate saline buffer of between 1 and 10 $\mu\text{g}/\mu\text{L}$. In some embodiments, the formulation comprises a concentration of the modified RNA formulated in citrate saline buffer of between 10 and 50 $\mu\text{g}/\mu\text{L}$.

[0302] In some embodiments, a method for preparing a formulation comprises combining the modified RNA with citrate saline buffer in accordance with this disclosure, wherein the formulation comprises a citrate saline buffer and is less toxic to the subject than a lipid-based formulation.

[0303] In some embodiments, a method for preparing a formulation comprises combining the modified RNA with citrate saline buffer in accordance with this disclosure, wherein the citrate saline buffer is substantially free of divalent cations, including calcium and magnesium. In some embodiments, the citrate saline buffer contains no calcium or magnesium.

[0304] In some embodiments, a method for preparing a formulation comprises combining the modified RNA with citrate saline buffer in accordance with this disclosure, wherein the formulation comprises a citrate saline buffer and further comprises a pharmaceutically acceptable excipient. In some embodiments, the pharmaceutically acceptable excipient is chosen from a solvent, dispersion media, diluent, dispersion, suspension aid, surface active agent, isotonic agent, thickening or emulsifying agent, preservative, core-shell nanoparticles, polymer, peptide, protein, cell, hyaluronidase, and mixtures thereof. In some embodiments, the solvent is an aqueous solvent.

2023208200 28 Jul 2023

[0305] Formulations can be administered to a subject via a number of routes in accordance with this disclosure. Special formulations suitable for intradermal, intracardiac, subcutaneous, and intramuscular injections are known in the art. For example, in order to prolong the effect of an active ingredient, it is often desirable to slow the absorption of the active ingredient from intramuscular injection. Delayed absorption of an intramuscularly administered drug form is accomplished by dissolving or suspending the drug (for example, a modified RNA) in an oil vehicle. Injectable depot forms are made by forming microcapsule matrices of the drug (for example, a modified RNA) in biodegradable polymers such as polylactide-polyglycolide. Depending upon the ratio of drug to polymer and the nature of the particular polymer employed, the rate of drug release can be controlled. Examples of other biodegradable polymers include poly(orthoesters) and poly(anhydrides). For intradermal and subcutaneous injections, the formulations are preferably formulated so that they do not induce an immune response when delivered to the intradermal compartment. Additives may be used in the formulations for intradermal injections include for example, wetting agents, emulsifying agents, or pH buffering agents. The formulations for intradermal injections may also contain one or more other excipients such as saccharides and polyols. For intracardiac injections, the formulations are preferably formulated so that they do not cause additional damages to the heart muscle and coronary arteries after the use of an injection needle. Suitable formulations for intracardiac injection are provided herein.

5.9. Method of Reducing Toxicity of Modified RNA Compositions

[0306] Some embodiments relate to a method of reducing toxicity of a modified RNA treatment in a subject, comprising formulating the modified RNA with citrate saline

2023208200 28 Jul 2023

buffer. In some embodiments, the formulation of modified RNA with citrate saline buffer is less toxic to the subject than a lipid-based formulation. In some embodiments, the toxicity of the lipid-based formulation is a dose-dependent toxicity. In some embodiments, the toxicity of the lipid-based formulation is a dose-limiting toxicity.

[0307] In some embodiments, a method of reducing toxicity of a treatment in a subject comprises formulating the modified RNA in accordance with this disclosure with citrate saline buffer and further comprises a pharmaceutically acceptable excipient. In some embodiments, the pharmaceutically acceptable excipient is chosen from a solvent, dispersion media, diluent, dispersion, suspension aid, surface active agent, isotonic agent, thickening or emulsifying agent, preservative, core-shell nanoparticles, polymer, peptide, protein, cell, hyaluronidase, and mixtures thereof. In some embodiments, the solvent is an aqueous solvent. In some embodiments, the solvent is a non-aqueous solvent.

[0308] In some embodiments, a method of reducing toxicity of a treatment in a subject comprises formulating the modified RNA in accordance with this disclosure with citrate saline buffer, wherein the subject is suffering from a disease responsive to VEGF-A therapy. In some embodiments, the subject is suffering from a disease chosen from heart failure with reduced or preserved ejection fraction, kidney disease, a disease involving skin grafting and tissue grafting, post-MI cardiac dysfunction, ischemic heart disease, a vascular injury from trauma or surgery, a skin ulcer including a diabetic ulcer, critical limb ischemia, pulmonary hypertension, and peripheral arterial disease. In some embodiments, the disease is heart failure with reduced or preserved ejection fraction. In some embodiments, the disease is post-MI cardiac dysfunction. In some embodiments, the disease is ischemic heart disease. In some embodiments, the disease is a vascular

2023208200 28 Jul 2023

injury from trauma or surgery. In some embodiments, the disease is a skin ulcer including a diabetic ulcer. In some embodiments, the disease is critical limb ischemia. In some embodiments, the disease is pulmonary hypertension. In some embodiments, the disease is peripheral arterial disease. In some embodiments, the disease is peripheral arterial disease. In some embodiments, the disease is kidney disease. In some embodiments, the disease is a disease involving skin grafting and tissue grafting.

5.10. Nucleic Acid Sequences

[0309] Some embodiments relate to a nucleic acid sequence comprising an *in vitro* transcription template for the generation of the modified RNA. In some embodiments, a nucleic acid sequence comprises an *in vitro* transcription template for the generation of the modified RNA in accordance with this disclosure.

[0310] Once a transcription template for the generation of the modified RNA is available, modified RNAs in accordance with this disclosure may be prepared according to any available technique well known in the art, using commercially available starting materials (see, e.g., U.S. Patent Application Publication No. 2015/0051268; U.S. Patent No. 8,710,200; U.S. Patent Application Publication No. 2013/0259923; all of which are incorporated by reference).

[0311] All of the claims in the claim listing are herein incorporated by reference into the specification in their entireties as additional embodiments.

6. EXAMPLES

6.1. EXAMPLE 1

Transfection of VEGF-A modified RNA and production of VEGF-A protein

2023208200 28 Jul 2023

[0312] For investigating the transfection potential of the VEGF-A modified RNA, 10,000 cells were seeded into 96-well plates in regular culture medium. For preparing conditioned media containing modified RNA-produced VEGF-A, 250,000 human umbilical vein endothelial cells (HUVEC) (Lonza, Basel, Switzerland) were seeded in six-well plates in endothelial growth medium (EGM) medium (Lonza). The next day transfection was undertaken in serum-free endothelial basal medium (EBM) media (Lonza). VEGF A modified RNA (amounts indicated) were mixed with Lipofectamine 2000 (Invitrogen, Carlsbad, CA, USA) according the manufacturer's instructions and added to the cells. As a transfection control, Lipofectamine 2000 mixed with water was used. After 4 hours the transfection medium was removed and changed to fresh serum-free EBM medium and media was collected at specified time points. Conditioned medium was collected after 24 hours and kept at -80°C. Human VEGF A concentration was measured with ELISA as described below.

[0313] The amount of human VEGF-A in the cell culture medium post transfection was measured with a human VEGF-A ELISA kit (Novex, Invitrogen) according to the manufacturer's instructions. Absorbance was read at 450 nm in a SpectraMax reader and the VEGF A concentration in the samples was calculated.

[0314] For all transfections of the VEGF-A modified RNA into cells *in vitro*, lipofectamine 2000 was required. VEGF-A modified RNA could be transfected into multiple human cardiac cell types. A higher dose of modified RNA resulted in production of more VEGF-A protein (FIG. 2A). The protein production from the modified RNA peaked approximately 8 hours after transfection, and then declined (FIG. 2B). In addition, the modified RNA transfection and protein production worked across species and both

mouse cardiac fibroblasts and pig endothelial cells could be transfected, which resulted in translation of the VEGF-A protein (FIG. 2C).

6.2. EXAMPLE 2

Activation of VEGF Receptor 2 signalling by recombinant and modified RNA-produced VEGF-A

[0315] One hundred thousand HUVEC were seeded into 12-well plates in EGM medium. The next day, cells were starved for 24 hours in EBM and then exposed to 100 ng/mL VEGF-A, either recombinant (R&D Systems, Minneapolis, MN, USA) or modified RNA-produced (added as conditioned media) or to media without VEGF-A. Stimulation was terminated after 2, 10 and 20 min and the medium was removed. Total protein was prepared from cultured cells with lysis buffer containing protease and phosphatase inhibitors (Mesoscale Discovery, Rockville, MD, USA). Protein concentrations were measured using the BCA Protein Assay kit (Pierce, Rockford, IL, USA) according to the manufacturer's protocol.

[0316] Fifteen micrograms of protein was loaded on a 4 to 12% Bis-Tris gradient gel and electrophoresis was carried out using MES SDS running buffer (Invitrogen). Fractionated protein was electroblotted onto a polyvinyl difluoride (PVDF) membrane (Invitrogen). Membranes were blocked in 5% BSA in TBS Tween (0.1%) and, subsequently, incubated with primary antibodies at 4°C overnight. Primary antibodies used were against VEGF Receptor 2 (VEGFR2), phosphorylated VEGFR2 (p-VEGFR2), Akt, phosphorylated Akt (p-Akt), eNOS (all from CellSignaling, Danvers, MA, USA), and phosphorylated eNOS (p-eNOS, BD Biosciences, Franklin Lakes, NJ, USA). Membranes were incubated with a horseradish peroxidase-labelled secondary antibody

(Dako, Glostrup, Denmark) and immunoreactions were detected using the ECL Western blotting substrate (Pierce). Chemiluminescent signals were visualized using a ChemiDoc Touch Imaging System (BioRad, Hercules, CA, USA).

[0317] To verify that the VEGF-A protein produced from the modified RNA was active, conditioned medium from cells transfected with VEGF-A modified RNA was added to cultured cells. This resulted in phosphorylation of the main VEGF-A receptor, VEGF receptor 2, in human endothelial cells (FIG. 3A). In addition, conditioned medium also induced phosphorylation of the downstream signalling pathways eNOS in human endothelial cells (FIG. 3B) and Akt in mouse cardiac fibroblasts (FIG. 3C), respectively.

6.3. EXAMPLE 3

The modified RNA produced VEGF-A protein is an active protein that stimulated several critical steps in the angiogenic process

[0318] HUVEC were seeded in 96-well plates, at a density of 3000 cells per well, in EGM medium (Lonza). The next day, medium was changed to basal EBM medium supplemented with 2% fetal bovine serum (FBS) and recombinant VEGF-A (R&D Systems) or to conditioned medium containing modified RNA-produced VEGF-A, supplemented with 2% FBS. VEGF-A concentrations were 10 ng/mL, 50 ng/mL and 100 ng/mL, respectively. Medium without VEGF-A was used as control. Plates were kept at 37°C in 5% CO₂ and two days later fixed in 4% buffered formaldehyde (Histolab, Gothenburg, Sweden) and nuclei stained with Hoechst (Invitrogen) for 10 min. Nuclear count was determined in the Image Express High Content Analysis System.

[0319] HUVEC were stained with Cell Tracker Red (Molecular Probes, Eugene, Oregon, USA) according to the manufacturer's instruction and seeded in EBM medium

2023208200 28 Jul 2023

supplemented with 2% serum in transwell inserts with a FloroBlok membrane with 8 μm pore size in a 24-well plate (Corning, New York, USA). EBM with 2% serum with human recombinant VEGF-A (R&D Systems) or conditioned medium containing modified RNA-produced VEGF-A with 2% serum were added to the lower chamber. VEGF-A as chemoattractant was studied at concentrations of 10 ng/mL and 100 ng/mL, respectively. Medium without VEGF-A was used as control. After 24 hours, cells that had migrated to the lower side of the membrane were counted with the Image Express High Content Analysis System.

[0320] HUVEC were mixed with Cytodex 3 microcarrier beads (GE Healthcare, Little Chalfont, United Kingdom) in EBM and tubes were kept at 37°C and flicked regularly to allow for even coating. After 4 hours, beads coated with endothelial cells were seeded in flasks and kept at 37°C and 5% CO₂ overnight. Beads were suspended at 500 beads/mL in a fibrinogen solution (2 mg/mL, Sigma Aldrich, St. Louis, MO, USA) containing aprotinin (0.15 Units/mL, Sigma Aldrich), and then added to wells containing thrombin (0.625 Units/mL, Sigma Aldrich) in 96-well plates. After 15 min the fibrin gel had formed a clot and EGM medium with recombinant VEGF-A or conditioned medium containing modified RNA-produced VEGF-A was added. As a control, medium without VEGF-A was used. Plates were kept at 37°C and 5% CO₂ for 2 days when angiogenic sprout formation was evaluated. Cells were stained with calcein for 30 min and plates were read in Image Express High Content Analysis System and sprout formation was determined.

[0321] As depicted, several critical steps in the angiogenic process were affected by the modified RNA-produced VEGF-A protein. VEGF-A increased

proliferation (FIG. 4A) and migration (FIG. 4B) of cultured human endothelial cells. In addition, angiogenic sprout formation in 3D culture with beads coated with endothelial cells was increased by modified RNA-produced VEGF-A (FIG. 4C and FIG. 5). Importantly, in endothelial cells the modified RNA-produced VEGF-A protein induced similar responses compared to recombinant VEGF-A protein, which shows that the modified RNA-produced VEGF-A retains its properties and ability to affect angiogenesis.

6.4. EXAMPLE 4

Assessment of β -galactosidase protein following single intracardiac injection of LacZ modified RNA in the mouse

[0322] Male C57Bl/6 mice (10 to 12 weeks old) were anesthetized with isoflurane. The left thoracic region was shaved and sterilized and following intubation the heart was exposed through a left thoracotomy. LacZ modified RNA formulated in citrate/saline (10 mmol/L citrate, 130 mmol/L sodium chloride in Hyclone water, pH adjusted to approximately 7.5 with sodium hydroxide) or Lipofectamine[®] (RNAiMAX Transfection Reagent, Thermo Fisher Scientific Inc. NY, USA), was injected (50 μ L) in the left ventricular free wall from the apex towards the base of the heart. After the injection, the thorax and the skin were closed by suturing and excess air was removed from the thoracic cavity by gentle chest compression. Subsequently, when normal breathing was established the mouse was disconnected from the ventilator and brought back to its home cage. At predefined time points following the cardiac injection, the mouse was anesthetized and the chest opened a second time. The heart was excised and the transfection efficiency and presence of the reporter β -galactosidase enzyme were

2023208200 28 Jul 2023

examined by 5-bromo-4-chloro-3-indolyl- β -D-galactopyranoside (X-gal) staining. X-gal is hydrolyzed by the enzyme yielding an intensely blue insoluble product indicative of the presence of an active β -galactosidase. Briefly, the organ or tissue was rinsed in phosphate buffer and fixated in 4% paraformaldehyde for 15 min and the washed 3 times (20 to 30 min) with 0.1 mmol/L phosphate (pH 7.3) wash buffer containing 2 mmol/L $MgCl_2$, 0.01% sodium deoxycholate and 0.02% Nonidet P40. Subsequently, freshly prepared X-gal solution (phosphate wash buffer containing 5 mmol/L $K_4Fe(CN)_6$, 5 mmol/L $K_3Fe(CN)_6$ and 1 mg/mL X-gal) was added to the specimen which then was wrapped in foil and incubated at 37°C overnight. The specimen was then washed with phosphate wash buffer 3 times and photographed.

[0323] Following a left thoracotomy, anaesthetized mice were given a single intracardiac injection of citrate/saline or LacZ modified RNA. Approximately 24 hours later the mice were sacrificed and hearts excised. The hearts were then subjected to X-gal staining overnight. FIGs. 6B and 6C illustrate efficient, and qualitatively similar, transfection and production of β galactosidase enzyme in the apical area injected with modified RNA formulated in lipofectamine (FIG. 6B) or citrate/saline buffer (FIG. 6C). No staining was observed in hearts injected with citrate/saline only (FIG. 6A).

6.5. EXAMPLE 5

Assessment of luciferase protein expression following intracardiac injection of luciferase modified RNA in naive mice

[0324] Male C57Bl/6 mice (10 to 12 weeks old) were anesthetized with a mix of ketamine (10 mg/kg) and xylazine (3.5 to 4 mg/kg) administered via intraperitoneal

2023208200 28 Jul 2023

injection. The left thoracic region was shaved and sterilized and following intubation the heart was exposed through a left thoracotomy.

[0325] The firefly luciferase modified RNA was formulated with the following buffers:

1. PBS buffer (1xPBS, no calcium, no magnesium, pH 7.4)
2. Citrate saline buffer (C/S, 10 mmol/L citrate, 130 mmol/L sodium chloride in Hyclone water, pH 7.0)
3. THAM buffer (tromethamine AKA 2-amino-2-(hydroxymethyl)-1,3-propanediol), 300 mmol/L Tris-HCl, pH 8.0)

[0326] A total of 25 µg of luciferase modified RNA was injected (50 µL) in the left ventricular free wall from the apex towards the base of the heart. After the injection, the thorax and the skin were closed by suturing and excess air was removed from the thoracic cavity by gentle chest compression. Post-surgery, the mouse received an intraperitoneal injection atipamezole hydrochloride (1 mg/kg) and a subcutaneous injection of buprenorphine hydrochloride (0.02 mg/kg). Subsequently, when normal breathing was established, the mouse was disconnected from the ventilator and brought back to its home cage.

[0327] Following a left thoracotomy, anaesthetized mice were given a single intracardiac injection of buffer only (PBS, C/S or THAM controls) or firefly luciferase modified RNA formulated in PBS, C/S, or THAM buffer. The hearts were excised for luciferase protein expression assessment via bioluminescence IVIS imaging. The results presented below are the combination of two staggered mouse studies. Table 2 reports the

2023208200 28 Jul 2023

individual raw IVIS bioluminescence flux values and FIG. 7 illustrates the graphed average values for all treatment groups, respectively.

Table 2. Raw IVIS bioluminescence data in mice hearts injected with control buffers only or luciferase modified RNA formulated in any of the buffers.

	Average Flux	n	#1	#2	#3	#4
C/S	6.24E+03	2	5.05E+03	7.42E+03		
C/S+Luc	6.43E+06	3	2.26E+06	1.41E+05	1.69E+07	
THAM	5.32E+03	2	4.03E+03	6.61E+03		
THAM+Luc	3.62E+06	3	1.82E+06	2.93E+06	6.10E+06	
PBS	1.02E+04	2	2.39E+03	1.79E+04		
PBS+Luc	1.01E+07	3	7.84E+06	3.14E+06	1.94E+07	
C/S+Luc	4.91E+06	3	2.49E+06	1.93E+06	1.03E+07	

[0328] As depicted in FIG. 7, luciferase protein expression was detected in all hearts injected with luciferase modified RNA, whereas the negative controls (PBS, C/S and THAM) show little to no signal. Baseline IVIS bioluminescent signal in these controls fluctuates from ~4 to 7.5+E03 units bioluminescent flux, expressed as photons/second. A 3 to 4 order of magnitude in luciferase signal was detected in all hearts injected with luciferase modified RNA. No statistical difference was detected between the various buffers.

6.6. EXAMPLE 6

Assessment of human VEGF-A protein production following intracardiac injection of human VEGF-A modified RNA in the rat

[0329] Male Sprague Dawley rats (body weight 250 to 300 g) were anesthetized with isoflurane and subcutaneously injected with marcaine (25 mg/kg) and buprenorphine

2023208200 28 Jul 2023

(0.05 mg/kg) for analgesia. The left thoracic region was shaved and sterilized and following intubation the heart was exposed through a left thoracotomy at the fifth intercostal space. Human VEGF-A modified RNA (1800, 150 or 15 μg) formulated in citrate saline (10 mmol/L citrate, 130 mmol/L sodium chloride in Hyclone water, pH adjusted to approximately 7.5 with sodium hydroxide) was injected as six separate injections (15 μL each, total volume 90 μL) along a line in the left ventricular free wall. After the injection, the thorax and the skin were closed by suturing and excess air was removed from the thoracic cavity by gentle chest compression. Subsequently, when normal breathing was established the rat was disconnected from the ventilator and brought back to its home cage. At predefined time points following the cardiac injection, the rat was anesthetized and the chest opened a second time for heart tissue sampling. The heart was excised and the right ventricle and the left and the right atria trimmed off. A transverse slice including the injection sites was excised, divided in two parts that were snap frozen in liquid nitrogen and stored at -80°C until analysis of VEGF-A protein. A separate tissue sample was taken from the apex remote from the injections site as a negative control.

[0330] Anaesthetized rats were intracardially injected with 3 different doses (15, 150 or 1800 μg) of VEGF-A modified RNA formulated in citrate/saline. Each dose was administered as six separate injections across the left ventricular free wall at one single time point. The animals were sacrificed at different time points following the injections, the hearts were excised and ventricular tissue harvested for VEGF-A protein content analysis. FIG. 8A summarizes the time profiles and the magnitude of VEGF-A protein produced for each of the three doses injected. As can be seen the protein production was

not dose linear and a 10-fold increase in dose from 15 to 150 µg gave rise to a 1.6-fold increase in the area under the curve (AUC) only, and a similar AUC was observed for the 150 and 1800 µg dose groups (1.1-fold difference).

6.7. EXAMPLE 7

Effects on of left ventricular function and infarct size following intracardiac injection of human VEGF-A modified RNA in rats subjected to myocardial infarction

[0331] Male Sprague Dawley rats (body weight 250 to 300 g) were anesthetized, pretreated and thoracotomized as described above. The animals were subsequently subjected to permanent ligation of the left anterior descending coronary artery to induce myocardial infarction. The ligation was followed by intracardiac injection of 90 µL of either citrate/saline (10 mmol/L citrate, 130 mmol/L sodium chloride in Hyclone water, pH adjusted to approximately 7.5 with sodium hydroxide), or 150 or 1800 µg human VEGF-A modified RNA formulated in citrate/saline. The entire volume was delivered as six separate epicardial injections along the border zone of the infarct. After the injections, the thorax and the skin were closed by suturing and excess air was removed from the thoracic cavity by gentle chest compression. Subsequently, when normal breathing was established the rat was disconnected from the ventilator and brought back to its home cage.

[0332] One and eight days after the procedure the animals were brought to the imaging facilities for assessment of left ventricular function and infarct size via magnetic resonance imaging (MRI). Furthermore, the day after the procedure a blood sample was drawn from the tail vein for analysis of cardiac troponin I (i-STAT[®] cardiac troponin I

2023208200 28 Jul 2023

diagnostic test, Abbott Point of Care Inc., Abbott Park, IL 60064, USA) as a biomarker for cardiac damage. The MRI scanning was undertaken using a dedicated small animal MRI system at a field strength of 4.7T. The images were acquired in the short-axis orientation, and stacks of images covering the left ventricle were acquired.

Electrocardiography was used for triggering imaging at specific phases in the cardiac cycle. Cardiac function was evaluated from an image series demonstrating the movement of the left ventricular wall during one heartbeat. The imaging sequence used when acquiring the image series was a gradient-echo sequence with a transversal repetition time of 10 ms and a flip angle of 25. The volume of the left ventricle was assessed via manual delineation at different time points by an experienced reader using dedicated image analysis software. The end-systolic (ESV) and end-diastolic (EDV) volumes were identified as the smallest and the largest left ventricular volumes. The ejection fraction (EF), reflecting cardiac function, was assessed via the formula $EF=(EDV-ESV)/EDV$.

Images demonstrating the extent of a cardiac infarct were acquired after administration of Gadodiamide, a contrast agent containing Gadolinium. Ten min prior to image acquisition 0.3 mmol/kg Gadodiamide was injected via a tail-vein catheter. Imaging was performed using a gradient-echo sequence, where contrast preparation included the use of an inversion pulse. The repetition time was minimum 900 ms, and the flip angle was 90 . The volumes of the left ventricular wall (LVV) and of the infarct (IV) were assessed by an experienced reader via manual delineation using dedicated image analysis software. The infarct size (IS), expressed as the infarcted fraction of the left ventricular wall, was determined via the formula $IS=IV/LVV$.

2023208200 28 Jul 2023

[0333] Twenty seven rats were subjected to permanent ligation of the left anterior descending coronary artery and intracardiac injections of citrate/saline (n=8) or a low (150 µg, n=9) or high (1800 µg, n=10) dose of VEGF-A modified RNA formulated in citrate/saline. The animals were followed for 8 days and effects on left ventricular ejection fraction and infarct size were assessed by MRI at day 1 and day 8 following the induction of the infarction. Cardiac TnI was measured in venous blood at day 1 as a biomarker of cardiomyocyte injury. As the two doses of VEGF-A modified RNA gave rise to similar amounts of VEGF-A produced, data from both groups were pooled in the efficacy analysis. As compared to the citrate/saline-treated rats, the animals administered VEGF-A modified RNA had a significantly higher left ventricular ejection fraction day 8 (FIG. 8B) and lower levels of cardiac TnI day 1 (FIG. 8D). Furthermore, the actively treated rats tended to have reduced infarct size vs the vehicle-treated rats (FIG. 8C).

6.8. EXAMPLE 8

Assessment of β -galactosidase and human VEGF-A protein following intracardiac injection of LacZ modified RNA or human VEGF-A modified RNA in Göttingen mini pigs

[0334] Female Göttingen mini pigs (body weight ~25 kg) fasted overnight were sedated through an intramuscular injection of midazolam and ketamine. Following sedation, an intravenous line was placed in the auricular marginal vein for induction of anaesthesia by propofol and the pig was endotracheally intubated. The pig was then transferred to the laboratory and connected to a ventilator. General anesthesia was maintained by isoflurane delivered through a precision vaporizer and a circle absorption breathing system with periodic arterial blood gas monitoring. Vital signs (heart rate,

2023208200 28 Jul 2023

blood pressure, respiration rate, O₂ pulse oxymeter, ECG and body temperature) were continuously monitored throughout the experiment. Intravenous fluid therapy was given throughout the procedure with the rate adjusted to replace blood loss or in case of low systemic blood pressure. A left thoracotomy to expose the heart was carried out and LacZ modified RNA or VEGF-A modified RNA (at varying volumes and doses) was injected in the left ventricular free wall at a depth approximately 5 mm from the epicardial surface. The injection site was marked with a small suture and 6 hours later the heart was excised. Transmural tissue slabs were harvested at the injection sites and X-gal stained for β -galactosidase as described above. For VEGF-A protein analysis, each tissue slab was divided in 6 separate specimens from epicardium to endocardium. These specimens were snap frozen in liquid nitrogen and stored at -80 °C until VEGF-A analysis as described below.

[0335] LacZ or VEGF-A modified RNA was epicardially injected in the left ventricular free wall and tissue sampled 6 hrs later for X-gal staining or VEGF-A protein analysis. In pigs administered LacZ modified RNA, the production of β -galactosidase was qualitatively similar when lipofectamine was used as transfection medium (FIG. 9A) as when citrate/saline was used (FIG. 9B).

6.9. EXAMPLE 9

Quantification of human VEGF-A protein in cardiac tissue

[0336] Tris lysis buffer containing phosphatase inhibitors I and II and protease inhibitor (Meso Scale Discovery (MSD), Rockville, MD, USA) was added to the frozen tissue biopsies and frozen at approximately -20 °C prior to homogenization. Ceramic beads (3 mm) were then added and the samples homogenized using the Precellys

2023208200 28 Jul 2023

homogenizer instrument. The homogenates were centrifuged and the supernatants stored at -80 °C prior to analysis.

[0337] VEGF-A concentrations were determined using a sandwich immunoassay with electrochemical luminescent detection. MSD V-PLEX cytokine Panel 1 (human) VEGF-A kits were used to measure the VEGF-A concentration in the tissue homogenates. The assay was performed as per the kit instructions. Standards were serially diluted 1 in 2 with the kit diluent and additional controls were included within each batch to monitor assay performance. Samples were diluted a minimum of 1 in 10 with the kit diluent prior to analysis and the plates read on the MSD Sector 600 instrument.

[0338] FIG. 10 summarizes the dose-dependent production of VEGF-A at 6 hours following epicardial injections of varying doses (50 to 2000 µg per injection) of VEGF-A modified RNA formulated in citrate/saline. The levels of protein produced indicate saturation at low doses of injected VEGF-A modified RNA, which is in line with the findings in the rat (FIG. 8A).

6.10. EXAMPLE 10

LacZ and Luciferase modified RNA cardiac transfection and translation in a citrate saline buffer

[0339] As depicted, 75 µg of LacZ encoding modified RNA with cardiac injections was transfected and translated in approximately 10% of the left ventricle (FIGs. 11A, 11B, 11C, and 11D). RNA in situ hybridization for luciferase modified RNA revealed staining expression in the myocardium at the site of injection (FIGs. 11E and

11F) and correlative luciferase protein expression shown via immunohistochemical analysis in the serial section (FIG. 11G).

6.11. EXAMPLE 11

VEGF-A protein expression after modified RNA injection to the heart with citrate saline buffer is saturable and has similar pharmacokinetics across multiple species

[0340] To compare VEGF-A protein production, 150 μg of VEGF-A modified RNA in a citrate saline buffer and 100 μg of VEGF-A modified RNA using RNAiMax (a lipid-based formulation) as the delivery carrier were injected into a rat heart. After 24 hours, VEGF-A protein levels in the rats with the citrate saline buffer (NTB) was at a comparable level to rats injected with RNAiMax and the pharmacokinetic profile were similar (FIG. 12A). The protein expression was dose limited and saturable, which was seen across species (FIG. 12B). With a ten-fold increase in dose, there was only a 1.6-fold increase in the area under the curve (FIG. 12C).

6.12. EXAMPLE 12

Assessment of human VEGF-A protein production following intracardiac injection of human VEGF-A modified RNA in the mouse, rat and pig

[0341] To compare VEGF-A protein production, 150 μg of VEGF-A modified RNA in a citrate saline buffer and 100 μg of VEGF-A modified RNA using RNAiMax (a lipid-based formulation) as the delivery carrier were injected into a rat heart. After 24 hours, VEGF-A protein levels in the rats with Male C57Bl/6 mice (10 to 12 weeks old) were anesthetized with isoflurane. The left thoracic region was shaved and sterilized and following intubation the heart was exposed through a left thoracotomy. One hundred μg

2023208200 28 Jul 2023

VEGF-A modified RNA (encoding the human VEGF-A protein (VEGF-A)) formulated in citrate saline (10 mmol/L citrate, 130 mmol/L sodium chloride in Hyclone water, pH adjusted to approximately 7.5 with sodium hydroxide) was injected (50 μ L) in the left ventricular free wall from the apex towards the base of the heart. After the injection, the thorax and the skin were closed by suturing and excess air was removed from the thoracic cavity by gentle chest compression. Subsequently, when normal breathing was established the mouse was removed from the ventilator and brought back to its home cage. At predefined time points following the cardiac injection, the mouse was anesthetized and the chest opened a second time for heart tissue sampling. The heart was excised and the right ventricle and the left and the right atria trimmed off. The remaining cardiac tissue (i.e., the left ventricular free wall and the intraventricular septum) was snap frozen in liquid nitrogen and stored at -80°C until analysis of VEGF-A protein as described below.

[0342] Male Sprague Dawley rats (body weight 250 to 300 g) were anesthetized with isoflurane and subcutaneously injected with marcaine (25 mg/kg) and buprenorphine (0.05 mg/kg) for analgesia. The left thoracic region was shaved and sterilized and following intubation the heart was exposed through a left thoracotomy at the fifth intercostal space. Human VEGF-A modified RNA (100 μ g) formulated in citrate saline (10 mmol/L citrate, 130 mmol/L sodium chloride in Hyclone water, pH adjusted to approximately 7.5 with sodium hydroxide) was injected as three separate injections (20 μ L each, total volume 60 μ L) along a line in the left ventricular free wall. After the injection, the thorax and the skin were closed by suturing and excess air was removed from the thoracic cavity by gentle chest compression. Subsequently, when normal

2023208200 28 Jul 2023

breathing was established the rat was disconnected from the ventilator and brought back to its home cage. At predefined time points following the cardiac injection, the rat was anesthetized and the chest opened a second time for heart tissue sampling. The heart was excised and the right ventricle and the left and the right atria trimmed off. A transverse slice including the injection sites was excised, divided in two parts that were snap frozen in liquid nitrogen and stored at -80°C until analysis of VEGF-A protein as described below.

[0343] Female Göttingen mini pigs (body weight ~ 25 kg) fasted overnight were sedated through an intramuscular injection of midazolam and ketamine. Following sedation, an intravenous line was placed in the auricular marginal vein for induction of anaesthesia by propofol and the pig was endotracheally intubated. The pig was then transferred to the laboratory and connected to a ventilator. General anesthesia was maintained by isoflurane delivered through a precision vaporizer and a circle absorption breathing system with periodic arterial blood gas monitoring. Vital signs (heart rate, blood pressure, respiration rate, O_2 pulse oxymeter, ECG and body temperature) were continuously monitored throughout the experiment. Intravenous fluid therapy was given throughout the procedure with the rate adjusted to replace blood loss or in case of low systemic blood pressure. A left thoracotomy to expose the heart was carried out and VEGF-A modified RNA (100 μg formulated in citrate saline (10 mmol/L citrate, 130 mmol/L sodium chloride in Hyclone water, pH adjusted to approximately 7.5 with sodium hydroxide) was injected in the left ventricular free wall at a depth approximately 5 mm from the epicardial surface. The injection site was marked with a small suture and 6 hours later the heart was excised. Transmural tissue slabs were harvested. For VEGF-A

2023208200 28 Jul 2023

protein analysis, each tissue slab was divided in 6 separate specimens from epicardium to endocardium. These specimens were snap frozen in liquid nitrogen and stored at -80 °C until VEGF-A analysis as described below.

[0344] As illustrated in FIGs. 13 A and 13B, the amount of protein produced peaked approximately at 6 to 12 hours after injection and the magnitude of and the time profiles for VEGF A protein produced were similar across species. Human VEGF-A protein was still observed in cardiac tissue 192 hours after the injection in the rat (FIG. 13B).

6.13. EXAMPLE 13

Effects on of left ventricular function and infarct size following intracardiac injection of human VEGF-A modified RNA in pigs subjected to myocardial infarction

[0345] Thirty four sexually mature Lanyu mini-pigs (~5 months old) of either sex were fasted overnight and anaesthetised, endotracheally intubated and artificially ventilated through a respirator with a mixture of oxygen, air and isoflurane. Vital signs (heart rate, blood pressure, respiration rate, O₂ pulse oxymeter, ECG and body temperature) were continuously monitored throughout the experiment. Intravenous fluid therapy was given throughout the procedure with the rate adjusted to replace blood loss or in case of low systemic blood pressure. A left thoracotomy to expose the heart was carried out and a permanent occlusion of the mid-left anterior descending coronary artery was undertaken in all pigs except in 5 in which the artery was not occluded (sham group). Subsequently, the chest was closed and the pig transitioned to an intensive care unit for approximately 2 hours after it was brought back to its pen to. Before and after the

2023208200 28 Jul 2023

surgery, analgesics and antibiotics were administered to relieve pain and prevent infection.

[0346] Seven days after the initial surgery, the pigs were prepared for a second surgery as described above and brought back to the operating theater. After the preparation, the infarcted pigs were randomised to a blinded treatment with citrate/saline (n=8), VEGF-A modified RNA low dose (1 mg, n=8), VEGF-A modified RNA high dose (10 mg, n=8) or recombinant human VEGF-A protein formulated in self-assembling nanofibers (n=5). Although not approved for clinical use the nanofiber construct was included as a positive control therapy (Lin Y.D. et al., Science Transl Med, (2012) 4:146ra109; its entirety is incorporated herein by reference). Following a left thoracotomy, the study drugs were administered as 20 epicardial injections distributed in the peri-infarct/infarct area, each injection volume being 100 μ L. After the procedure, the pigs were treated as described above and left to recover for 2 months before the terminal experiments were carried out.

[0347] Throughout the study serial measurements of left ventricular function was assessed by means of echocardiography. Hence, measurements were undertaken under anesthesia in the closed-chest pigs immediately before and after induction of myocardial infarction, immediately before the intracardiac injection of the study drugs and on the day of sacrifice. Cardiac function was assessed by 2D echocardiography using Vivid Q with a 3.5 MHz probe (GE Healthcare, Horten, Norway). The pigs were placed in the left lateral decubitus position. Parasternal long-axis views were obtained by M mode to measure left ventricular volumes to derive left ventricular ejection fraction. At study end (i.e., 2 months after the study drug administration) the pigs were anaesthetised

2023208200 28 Jul 2023

as described above and instrumented for an invasive hemodynamic assessment by means of a pressure-volume loop recording catheter (Millar Instruments, Houston, Texas, USA) positioned in the left ventricular cavity via right carotid artery catheterization. The hemodynamic data were analyzed with a commercial software (AD Instruments). After the hemodynamic assessment, the pig was sacrificed and the heart harvested. The heart was washed three times and processed into five slices from apex to the papillary muscle level. Images were taken of each slice and the infarct sizes were estimated using a commercial software (ImageJ). Infarct size was calculated as a percentage of the area of the whole ventricle minus the area of the inner space.

[0348] Serial assessments of left ventricular ejection fraction (EF) were carried out during the course of the study. As can be seen in FIG. 14, the permanent occlusion of the left anterior descending coronary artery was associated with an immediate reduction in EF from approximately 65% to below 45%, a decline that remained 7 days after the occlusion when the study drugs were injected. No such reduction was seen in the pigs subjected to the sham procedure. Two months after the injections, pigs administered with VEGF-A modified RNA or recombinant VEGF-A protein formulated in self-assembling nanofibers were observed to have an improved EF vs the citrate/saline-injected pigs. When comparing the changes in EF from the day of injection until study end, a statistically significant improvement was seen for both VEGF-A modified RNA groups and the VEGF-A protein group but not for the citrate/saline group. The invasive hemodynamic assessment of left ventricular function carried out at study termination showed similar improvement as evidenced by the differences in maximal left ventricular pressure development over time (dp/dt max, FIG. 15), minimal pressure development

over time (dP/dt min, FIG. 16), endsystolic pressure volume relationship (ESPVR, FIG. 17), enddiastolic pressure volume relationship (EDPVR, FIG. 18) and preload recruitable stroke work (PRSW, FIG. 19), respectively.

[0349] Infarct size was measured after tissue harvesting at study end and was quantified as global left ventricular infarct size (slices 2, 3, 4 and 5, FIG. 20A), mid left ventricular infarct size (slices 3 and 4, FIG. 20B) and mid-most left ventricular infarct size (slice 4, FIG. 20C). As can be seen in FIGs. 20A, 20B and 20C, the VEGF-A modified RNA as well as the VEGF-A protein/nanofiber treatment were associated with a dose-dependent reduction in infarct size vs the citrate/saline-treated pigs.

6.14. EXAMPLE 14

***In vivo* effect of human VEGF-A modified RNA in a wound healing model in diabetic mice**

[0350] The purpose of this experiment was to determine if human VEGF-A modified RNA exhibits bioactivity in a diabetic mouse model of delayed cutaneous wound healing. Two trials were performed using the db/db mouse, which has a deficiency in leptin receptor expression due to a point mutation and experiences delayed cutaneous wound healing relative to healthy control mice. The db/db mouse has been widely used in the published literature to test therapeutic efficacy of various treatments aimed at accelerating wound healing. The first trial, Trial 1, included 32 male db/db mice and was designed to: 1) evaluate the effect of human VEGF-A modified RNA on wound healing rates, 2) determine if the treatment caused abnormalities in granulation tissue formation, and 3) determine the effect of human VEGF-A modified RNA on vascularity in the granulation tissue. The second trial, Trial 2, included 7 male db/db mice, and was

2023208200 28 Jul 2023

designed to evaluate oxygenation of the wound over time using ratiometric imaging of a novel boron-based oxygen-sensing nanoparticle. Briefly, on the first day of the trial (Day 0), 1 cm diameter full-thickness cutaneous wounds were surgically made on the dorsum of each mouse, and human VEGF-A modified RNA or vehicle control (n=8 mice per group) was immediately injected intradermally in the perimeter of the wound. In a sub-set of mice (n=8 mice per group), either human VEGF-A modified RNA or vehicle control was also delivered on Day 3. The wounds were bandaged using Tegaderm, and mice were housed individually in cages. Serial photographs of the wounds were acquired at subsequent timepoints, and at the terminal endpoint (Day 18), wound tissues were harvested and processed for immunohistochemistry (CD31+ staining for endothelial cells and hematoxylin and eosin (H&E) staining). In Trial 2, serial images of fluorescence and phosphorescence were acquired after delivering the oxygen-sensing nanoparticles topically to the wound bed after an experimental procedure similar to Trial 1 except that only dosing at day 0 and 3 was done. The results from Trial 1 showed that the sequential dosing of human VEGF-A modified RNA (100 µg on Day 0 and 100 µg on Day 3) significantly ($p<0.05$) decreased the open wound area at day 6 and day 10, relative to sequential dosing of vehicle control while single dosing of either human VEGF-A modified RNA or vehicle control did not. The average percent of wound closure between early time points (day 3 to 6) was significantly increased compared to vehicle control. CD31+ staining in the granulation tissue was also increased in mice receiving sequential dosing of human VEGF-A modified RNA. In Trial 2 the oxygen levels in the wounds at Day 6 were also significantly ($p<0.05$) increased in mice receiving 2 sequential doses of 100 µg of human VEGF-A modified RNA relative to the double-injected vehicle group.

This experiment supports that treatment of cutaneous wounds in the dorsum of diabetic mice with sequential dosing of human VEGF-A modified RNA significantly accelerates wound healing during the early, more clinically-relevant phase of wound healing.

Accelerated healing is accompanied by increases in vascularization of the granulation tissue and increased oxygenation of the wound bed at early time points.

[0351] Test compound and formulation

Test compound	Human VEGF-A modified RNA (FIG. 1B) (VEGF-A modified RNA as shown in figures accompanying Example 14)
Formulation	Citrate/saline (10 mmol/L/130 mmol/L, pH 7.5)

[0352] Test system

Justification for selection of test system	db/db mice used are an established model of Type II diabetes and a plethora of reports describe impaired wound healing as compared to wild type mice. Impaired wound healing of db/db mice allow for longer healing window to test drug bioactivity.
Strain	B6.BKS(D)- <i>Lepr^{db}/J</i> (db/db mice)
Sex	Male
Total No of animals	39 (Trial 1: 32 mice, Trial 2: 7 mice)

[0353] Study design

Dose(s)	Trial 1; 25 µg VEGF-A modified RNA per injection site (4 sites total at each injection time point, 100 µg/animal in total). VEGF-A modified RNA concentration 2.5 µg/µL.
---------	--

2023208200 28 Jul 2023

	<p>Trial 1; 10 μL vehicle injections of 10 mmol/L citrate, NaCl 130 mmol/L</p> <p>Trial 2; 50 μL of 1 mg/mL nanoparticle solution for each imaging time point</p>
Volume(s) of administration	<p>10 μL of VEGF-A modified RNA or vehicle injected intradermally in four locations at the periphery of wound (40 μL total)</p> <p>Approximately 50 μL of nanoparticle solution added at each imaging time point for Trial 2.</p>
Route(s) and frequency of administration	<p>Intradermal injection of VEGF-A modified RNA or vehicle at Day 0 and Day 3. Day 0: injected at 0, 90, 180, and 270 degree positions. Day 3: injected at 45, 135, 225, and 315 degree position. No injections past Day 3.</p> <p>Nanoparticle solution applied topically to wound at each imaging time point (0, 3, 6, 10, 13, and 18 days).</p>
Duration of treatment	18 days
Number/group	<p>Trial 1; 8 mice per group</p> <p>Trial 2; 3 and 4 mice per group (see below)</p>
Number of groups	<p>Trial 1</p> <p>4 groups</p> <p>Group 1; single vehicle injection (Day 0, n=8, 1 mouse died before conclusion of study)</p> <p>Group 2; double vehicle injection (Day 0 and 3, n=8)</p> <p>Group 3; single human VEGF-A modified RNA</p>

2023208200 28 Jul 2023

	injection (Day 0, n=8) Group 4; double human VEGF-A modified RNA injection (Day 0 and 3, n=8, 1 mouse died before conclusion of study) Trial 2 (with nanoparticles) 2 groups Group 1; double vehicle injection (Day 0 and 3, n=4) Group 2; double human VEGF-A modified RNA injection (Day 0 and 3, n=3)
--	---

[0354] Experimental procedures

[0355] The experiments were divided into two trials, Trial 1 and Trial 2. Trial 1 focused exclusively on evaluating the bioactivity of the human VEGF-A modified RNA in the context of diabetic wound healing. Trial 2 again tested the bioactivity of the human VEGF-A modified RNA in the same wound healing model, but also employed the use of oxygen-sensitive nanoparticles to determine the oxygenation within the wound bed.

Procedures listed below are common to both Trials unless otherwise noted.

[0356] Full thickness skin wound (Day 0): Mice were anesthetized with a 2% inhalable isoflurane/oxygen mixture and were then depilated and sterilized prior to surgery. A 1 cm diameter circle was marked on the dorsum of the mouse using a stencil. Skin (including dermis and epidermis) was carefully excised from the outlined area to form the full thickness skin wound. Human VEGF-A modified RNA or vehicle was injected intradermally. An analgesic (buprenorphine, 0.1 mg/kg) was administered

2023208200 28 Jul 2023

following surgery, and the wounds were covered with a Tegaderm dressing and a self-adhering wrap.

[0357] Intradermal injections (Days 0 and 3): Ten μL x 4 of human VEGF-A modified RNA or vehicle (outlined above) were injected immediately after excision of skin. At Day 0 (day of wounding), human VEGF-A modified RNA or vehicle was injected into the dermal layer of the skin at 0, 90, 180, and 270 degree positions around the perimeter of the wounds. At Day 3, the human VEGF-A modified RNA or vehicle was injected intradermally at 45, 135, 225, and 315 degree positions around the perimeter of the wound to avoid injection in the same location twice.

[0358] Imaging procedure (Days 0, 3, 6, 10, 13 and 18): The self-adhering wrap and Tegaderm dressings were removed prior to imaging the wounds. Body masses were recorded each day before imaging (Day 0, 3, 6, 10, 13, and 18). Images were acquired at a fixed distance above the wound with a twelve megapixel camera while mice were anesthetized with a 2% inhalable isoflurane/oxygen mixture. After imaging, the wounds were covered with a new Tegaderm dressing and wrapped with the existing self-adhering wrap (unless nanoparticle imaging was to be performed).

[0359] Imaging procedure with oxygen-sensitive nanoparticles (Day 0, 3, 6, 10, 13, and 18): Imaging for oxygen levels was only performed in Trial 2. After imaging as described above, mice were kept anesthetized and placed on a temperature controlled microscope stage with a custom designed imaging platform. M-JPEGs were acquired under UV illumination for each wound consisting of 1) 10 frames (acquired at 3 frames/second) of wound prior to application of boron-based nanoparticles (BNP) and 2) 60 frames (acquired at 3 frames/second) after superfusion of 50 μL of nanoparticle

2023208200 28 Jul 2023

solution within the wound bed. After imaging, the wounds were covered with a new Tegaderm dressing and wrapped with the existing self-adhering wrap.

[0360] Wound oxygenation image analysis: Imaging for oxygen levels was only performed in Trial 2. The UV-illuminated wound images (acquired as described above) were analyzed using custom written MATLAB programs. To account for background signal, selected points within the wound bed were analyzed for the red and blue channel intensity prior to the addition of the nanoparticles. These background intensity values were subtracted from red and blue intensity values acquired after the addition of the nanoparticles. The ratio of blue channel intensity to red channel intensity was computed for each pixel to represent the ratio of fluorescence (constant in the presence of BNP) to phosphorescence (quenched in the presence of oxygen). The ratiometric images were then qualitatively displayed using a 256-value color map scaled to the ratio bounds to spatiotemporally resolve fluorescence-to-phosphorescence ratios. To quantify the amount of oxygen within the wound bed, the raw blue and red channel intensity values were used to construct a grayscale image (low oxygen; black pixels, high oxygen; white pixels). The wound bed was selected as the area of interest and quantified the mean gray pixel value was quantified using ImageJ software.

[0361] Harvest of tissue, histological sectioning, and staining (Day 18): Mice were euthanized via CO₂ asphyxiation and the final image was acquired of the wound. A 1.5 cm x 1.5 cm area around the wound center was excised and divided into longitudinal thirds for three separate analyses. One third of the tissue was snap frozen in liquid nitrogen and sent for assessment of downstream VEGF signaling proteins. The middle third of the tissue was fixed in 10% formalin for 1 week and processed for paraffin

2023208200 28 Jul 2023

embedding. Five μm sections were cut and stained with hematoxylin and eosine (H&E) and for CD31 (Santa Cruz Biotechnology, sc-1506, PECAM-1 (M-20)).

[0362] Blood glucose measurements (Day 0 and Day 18): Prior to initial wounding at Day 0, all mice were fasted for four hours in paper bedding cages without food. Initial fasted glucose measurements were taken before wounding. While harvesting the blood at Day 18, unfasted glucose measurements were undertaken and a small sample of blood sampled.

[0363] Data analysis

[0364] Wound area quantification: time point for Trials 1 and 2. Using ImageJ, the observers traced the perimeter wound and ImageJ calculated the area of the open wound. To account for differences between observers' judgment, the median value of the three wound areas was reported for each wound. Wound areas at each time point were normalized to the initial wound area (Day 0) to account for minor differences in the initial wound sizes. Data was statistically analysed using a repeated measures two-way ANOVA with significance asserted at $p < 0.05$. Cubic spline interpolation of these data was performed to compute the estimated time to 25%, 50%, and 75% closure of the wound, respectively. The average percent healing between time points was calculated by subtracting the percent of wound area remaining from the previous percent of wound area remaining. Data was analysed using a repeated measures two-way ANOVA with significance asserted at $p < 0.05$.

[0365] CD31 staining analysis (Trial 1): Histological cross-sections of the wound tissue were immunostained for CD31, and imaged using transmitted light microscopy with a 40x objective. The brown channel (positive CD31 labeling) was

2023208200 28 Jul 2023

thresholded to white and black to remove background and non-specific labelling. The thresholded percent area of CD31 positive staining was calculated for each of the treatment groups with n=3.

[0366] Hematoxylin and eosin staining analysis (Trial 1): Paraffin sections from each wound were stained with H&E and imaged using transmitted light microscopy using a 4x objective. Granulation tissue was visually inspected to qualitatively assess the thickness and continuity of the epidermis, cross-sectional area of granulation tissue (width and thickness), and presence or absence of any abnormal tissue structures, such as hemangiomas.

[0367] Downstream VEGF signalling analysis (Western blot) (Trial 1): Skin tissue samples were homogenized with RIPA Lysis Buffer (sc-24948, Santa Cruz Biotechnology, Santa Cruz, CA), and centrifuged, the protein concentrations of the supernatant was determined by Bradford protein assay (#5000112, Bio-Rad, Hercules, CA). Total protein 30 µg were loaded on a polyacrylamide gel (#3450124, Bio-Rad, Hercules, CA) and transferred to membrane (#1620232, Bio-Rad, Hercules, CA). The membrane was probed with the following antibodies: anti-pAKT antibody (S473, #4060, Cell Signaling, Danvers, MA) and anti-AKT antibody (#4691, Cell Signaling Technology, Danvers, MA), anti-rabbit IgG secondary antibody (IRDye 800CW, LI-COR biosciences, Lincoln, NE). Quantification of the pAKT and AKT bands was performed using the ImageJ program 29.

[0368] Body mass and blood glucose analysis: Body masses and blood glucose levels were statistically analysed using a repeated measures two-way ANOVA with significance asserted at $p < 0.05$.

2023208200 28 Jul 2023

[0369] Oxygen quantification analysis (Trial 2): The mean gray values of the raw nanoparticle images were statistically analysed using a repeated measures two-way ANOVA with significance asserted at $p < 0.05$.

[0370] Results

Results from wound area measurements (Trial 1)

[0371] The body mass for the db/db mice in all groups included in Trial 1 are shown in FIG. 21. The body masses were similar for all groups at all time points except the single injected vehicle group and single injected VEGF-A modified RNA group for which there was a significant ($p < 0.05$) difference at day 13. This difference is not thought to have an impact on the study results.

[0372] Fasted and fed glucose levels in the db/db mice for all groups at day 0 and at day 18 are shown in FIG. 22. All groups were similar except the single injected vehicle group and single injected VEGF-A modified RNA group for which there was a significant ($p < 0.05$) difference of 85 mg/dL at day 0. This difference is not thought to have an impact on the study results.

[0373] The results from measurements of the wound area during the 18 days observation time are shown in FIGS. 23-25. In terms of closure of open wound area, the single injected VEGF-A modified RNA group dose at day 0 did not show any significant effect compared to its single injected vehicle equivalent during the 18 days observation time. On the other hand, the group double injected with VEGF-A modified RNA at day 0 and 3 did show a significantly ($p < 0.05$) faster closure at day 6 with 55% open wound area and at day 10 with 27% open wound area compared to the group with double injected vehicle with day 6 open wound area of 71% and day 10 open wound area of 49%,

2023208200 28 Jul 2023

respectively (FIG. 23). Area under curve was for vehicle single injection 962.83, vehicle double injection 998.21, VEGF-A modified RNA single injection 895.12, VEGF-A modified RNA double injection 792.79, respectively. Time to 25% closure were for single injected vehicle 6.2 days, double injected vehicle 5.4 days, single injected VEGF-A modified RNA 5.1 days and double injected VEGF-A modified RNA 4.2 days, respectively (FIG. 24). Time to 50% closure were for single injected vehicle 8.9 days, double injected vehicle 9.8 days, single injected VEGF-A modified RNA 7.8 days and double injected VEGF-A modified RNA 6.3 days, respectively (FIG. 24) Time to 75% closure were for single injected vehicle 12.3 days, double injected vehicle 13.7 days, single injected VEGF-A modified RNA 12.5 days and double injected VEGF-A modified RNA 10.4 days, respectively (FIG. 24) When comparing the average percent of wound closure between time points the double injected VEGF-A modified RNA group showed significant ($p < 0.05$) difference with 40% change between day 3 to 6 compared to double injected vehicle group with 20% change while the single injected VEGF-A modified RNA group did not show significance compared to the single injected vehicle group (FIG. 25).

Results from histological evaluation (Trial 1)

[0374] Representative results from H&E-stained sections of the wound area at day 18 are shown in FIG. 26. This staining showed normal granulation tissues without any signs of abnormal tissue structures. In FIG. 27 representative CD31 positive stains are shown for the wound area sections after single and double injected vehicle and VEGF-A modified RNA, respectively. The quantification of the endothelial cell-based vessels in the wound area shown in FIG. 28 resulted in an increased thresholded percent

area with CD31 positive stains for both single (4.3 ± 4.0 , mean \pm SD) and double (8.4 ± 4.4) injected VEGF-A modified RNA in comparison to single (3.2 ± 0.6) and double (3.2 ± 0.6) injected vehicle, respectively.

Downstream VEGF signaling analysis with Western blot (Trial 1)

[0375] The results of the analysis of downstream VEGF signaling at day 18 including AKT and VEGFR2 are shown in FIG. 29 and FIG. 30. These results did not show any ongoing downstream signaling at day 18 (study end).

Results from measurements with oxygen sensing nanoparticles (Trial 2)

[0376] The body mass for the db/db mice included in the two groups, ie double injected vehicle and VEGF-A modified RNA, in Trial 2 are shown as a function of time in FIG. 31. The body masses were similar for all groups at all time points. Fasted and fed glucose levels at day 0 and day 18 respectively in the db/db mice for double injected vehicle and VEGF-A modified RNA in Trial 2 are shown in FIG. 32. The fasted and fed glucose levels were similar in both groups.

[0377] In Trial 2, oxygen sensitive nanoparticles were put into the wounds to estimate the oxygenation. In FIG. 33 a schematic of the technology behind the nanoparticle oxygen quantification is shown. At room temperature and after excitation the nanoparticles emit fluorescence captured by a blue channel signal and an oxygen-dependent phosphorescence captured by a red signal channel. When these signals are put together the result is an image of relative oxygenation in the wound. In FIG. 34 representative images for a double injected vehicle mouse and a double injected VEGF-A modified RNA mouse are shown as a function of time. The yellow and red colour is already at day 3 more prominent in the wound area of the double injected VEGF-A

2023208200 28 Jul 2023

modified RNA mouse compared to the double injected vehicle mouse. At day 6 there is a significant ($p<0.05$) increase in the oxygenation for the double injected VEGF-A modified RNA group compared to the double injected vehicle group (FIG. 35).

[0378] The results from measurements of the wound area during the 18 days observation time are shown in FIGs. 36-38. The group with double injected VEGF-A modified RNA at day 0 and 3 did show a significantly ($p<0.05$) faster closure at day 6 with 45% open wound area compared to the group with double injected vehicle with 62% open wound area, respectively. Time to 25% closure were for double injected vehicle 3.4 days and double injected VEGF-A modified RNA 3.8 days, respectively. Time to 50% closure were for double injected vehicle 7.1 days and double injected VEGF-A modified RNA 5.6 days, respectively. Time to 75% closure were for double injected vehicle 8.9 days and double injected VEGF-A modified RNA 7.8 days, respectively. When comparing the average percent of wound closure between time points the double injected VEGF-A modified RNA group did show significant ($p<0.05$) difference with 40% change between day 3 to 6 compared to double injected vehicle group with 14% change, respectively.

[0379] Conclusions

[0380] Intradermal administration of 100 μg VEGF-A modified RNA divided on 4 injection sites near the wound perimeter on both Day 0 and Day 3 post injury, significantly decreased the open wound area in in db/db mice at Day 6 and Day 10 relative to vehicle control.

[0381] Intradermal administration of 100 μg VEGF-A modified RNA divided on 4 injection sites near the wound perimeter on both Day 0 and Day 3 post injury,

2023208200 28 Jul 2023

significantly increased the average percent of wound closure between early time points (Day 3 to 6) compared to vehicle control.

[0382] Intradermal administration of 100 µg VEGF-A modified RNA divided on 4 injection sites near the wound perimeter on both Day 0 and Day 3 post injury, increases the area of CD31+ immunostaining in histological cross-sections of granulation tissue at Day 18 relative to vehicle control and relative to dosing with VEGF-A modified RNA at the initial time point (Day 0) only.

[0383] Intradermal administration of 100 µg VEGF-A modified RNA divided on 4 injection sites near the wound perimeter on both Day 0 and Day 3 post injury significantly increases the amount of oxygen in the wound at Day 6 relative to vehicle control.

6.15. EXAMPLE 15

Photoacoustic microscopy of the effects of human VEGF-A modified RNA on hemodynamics and neovascularization in the mouse ear *in vivo*

[0384] In this experiment, acute and chronic vascular responses to human VEGF-A modified RNA (VEGF-A modified RNA) were monitored in the healthy mouse ear *in vivo*. The multi-parametric photoacoustic microscopy (PAM) technique was applied to dynamically characterize the effect of VEGF-A modified RNA on the vascular diameter, oxygen saturation of haemoglobin (sO₂), blood flow, and neovascularization. Side-by-side and quantitative comparisons of the responses to VEGF-A modified RNA, recombinant human VEGF-A protein, and citrate/saline/ vehicle were performed. Furthermore, the dose dependence of the responses was explored by comparing the outcomes induced by high-dose (100 µg/ear) and low-dose (10 µg/ear) VEGF-A modified

2023208200 28 Jul 2023

RNA. The studies showed that VEGF-A modified RNA induced marked upregulation of the local blood flow near the injection site shortly after injection (30 minutes to 6 hours). In addition, significant capillary angiogenesis and neovascularization 7 to 14 days after the injection of high-dose VEGF-A modified RNA, but not in ears injected with low-dose VEGF-A modified RNA, VEGF-A protein or citrate/saline, were noted. Furthermore, VEGF-A modified RNA induced a striking and spatially confined upregulation in the microvascular blood flow downstream of the injection site, which was distinctly different from the highly concentrated response to the human recombinant VEGF-A protein.

[0385] The aim of the present study was to dynamically characterize the effect of VEGF-A modified RNA on the vascular diameter, oxygen saturation of haemoglobin (sO₂), blood flow, and neovascularization by means of the multi-parametric photoacoustic microscopy (PAM) technique in the healthy mouse ear in vivo.

[0386] Compound and formulation

Test compound	Human VEGF-A modified RNA (FIG. 1B) (VEGF-A modified RNA as shown in figures accompanying Example 15)
Formulation	Citrate/saline (10 mmol/L/130 mmol/L, pH 6.5)

The control/reference compound is recombinant human VEGF-A₁₆₅ protein from R&D Systems Inc, 614 McKinley Place NE, Minneapolis, MN 55413, USA.

[0387] Test system

Justification for selection of test system	All animal experiments were performed using the multi-parametric PAM (Ning et al 2015). It is heretofore the only available microscopy platform
--	---

2023208200 28 Jul 2023

	that can dynamically and comprehensively characterize the blood flow, perfusion, oxygen saturation, and neovascularization in vivo, and is thus ideally suited for this study.
Strain	C57BL/6
Sex	Female
Total No of animals	12

[0388] Study design

Dose(s)	Citrate/saline; NA High-dose VEGF-A modified RNA; 100 µg Medium-dose VEGF-A modified RNA; 30 µg Low-dose VEGF-A modified RNA; 10 µg VEGF-A protein; 1 µg
Volume(s) of administration	10 µL
Route(s) and frequency of administration	Intradermal, single injection
Duration of treatment	Acute (less than 5 minutes)
Number/group	1 to 3
Number of groups	5
Individual animal identification No/reference No	Group 1, high-dose (HD) VEGF-A modified RNA injected, 3 mice: HD no.1, HD no. 2, HD no.3 Group 2, low-dose (LD) VEGF-A modified RNA injected, 2 mice: LD no.1, LD no. 2 Group 3, medium-dose (MD) VEGF-A modified RNA injected, 1 mouse: MD no.1 Group 4, VEGF-A protein (P) injected, 3 mice: P no.1, P no.2, P no.3

2023208200 28 Jul 2023

	Group 5, citrate/saline injected, 3 mice: C/S no.1, C/S no.2, C/S no.3
--	---

[0389] Experimental procedures

[0390] For the mouse ear imaging, which is completely non-invasive, the same mouse can be repeatedly imaged for time-lapse monitoring of the effects of different drugs on the vascular diameter, sO_2 , blood flow, angiogenesis and neovascularization. A baseline image of the mouse ear was acquired prior to the intradermal injection of the study drugs. Then, the drug-treated ear was monitored for 6 hours to capture the acute vascular responses and reimaged on day 7 to record chronic hemodynamic responses and possible neovascularization. To examine the persistence of the VEGF-A modified RNA-induced vascular remodeling, the mice treated with high-dose VEGF-A modified RNA were further imaged on day 14, 21, and 28, respectively.

[0391] The detailed PAM imaging protocol was as follows: The mouse was anaesthetised in a small chamber flooded with 3% isoflurane inhalation gas (typical flow rate 1 to 1.5 L/min, depending on the body weight). Anaesthesia was maintained at 1.5% isoflurane throughout the experiment. Medical-grade air was used as the inhalation gas to maintain the mouse at normal physiological status. Pure oxygen is not suitable, because it elevates the venous blood oxygenation to be higher than the normal physiological level and biases the PAM measurement. Subsequently, the mouse was transferred from the anesthesia chamber to a nearby stereotaxic stage. The body temperature of the mouse was maintained at 37°C using a heating pad. Following positioning in the stereotaxic stage a layer of ultrasound gel was applied on the surface of the ear to be imaged. Care was taken to avoid trapping of air bubbles inside the gel. Then the ear was placed beneath a tank

2023208200 28 Jul 2023

filled with deionized water and slowly raised until the ultrasound gel gently came in contact with the tank bottom which was covered by a thin membrane of polyethylene. Ointment was applied to the eyes to prevent drying and accidental laser damage. The imaging head was then lowered until the acoustic lens was immersed in the water tank. Any air bubbles trapped under the lens were removed. Hence, vertically from top to bottom the set-up included the acoustic lens, the water tank, the ultrasound gel and the mouse ear. The laser fluence was then checked to make sure it operated within the laser safety standards of the American National Standards Institute (ie, 20 mJ/cm²). Following the image acquisition, the mouse ear was cleaned with deionized water and transported back to its home cage.

[0392] Three vascular parameters were simultaneously acquired by multi-parametric PAM (Ning et al., Simultaneous photoacoustic microscopy of microvascular anatomy, oxygen saturation, and blood flow. *Opt Lett*, 2015, 40:910-913). Vascular anatomy was directly generated by Hilbert-transformation of the PAM-acquired raw photoacoustic signals at each sampling position. Vascular sO₂ was acquired with dual-wavelength excitation to distinguish the oxy- and deoxy-hemoglobin via their optical absorption spectra. Blood flow speed was quantified by correlating 100 successive A-lines acquired at 532 nm. The time window for the correlation analysis was set to 10 ms. The time course of the computed correlation coefficient follows a second-order exponential decay and the decay constant, which is linearly proportional to the blood flow speed, was extracted for flow quantification. Further, the average diameter, sO₂, and blood flow of individual vessels were extracted with the aid of a documented vessel segmentation algorithm (Soetikno et al., Vessel segmentation analysis of ischemic stroke

images acquired with photoacoustic microscopy. Proc. SPIE, 2012, 8223:822345). The measurements of different animals within each groups were combined for statistical analysis.

[0393] Data analysis

[0394] Results shown are means \pm SD. To investigate the quantitative differences between citrate/saline, VEGF-A modified RNA, and human recombinant VEGF-A protein treated mice a mixed model for the repeated measurements was used for performing the statistical analysis. An individual intercept model with autoregressive structure of the covariance matrix was fitted to the difference in vessel diameter or volumetric flow from baseline. Additionally, baseline vessel diameter or volumetric flow was used as a covariate to correct for any differences.

[0395] Results

[0396] The high dose of VEGF-A modified RNA was intradermally injected in the ear of three healthy mice. Representative time-lapse PAM images of vascular structure, sO₂ and blood flow are shown in FIG. 39. Shortly (ie, up to 6 hours) after injection, significant upregulation in vascular sO₂ and blood flow were observed at the periphery of the injection site in all three mice. PAM images repeatedly acquired on day 7, 14, 21, and 28 showed that the previously upregulated sO₂ gradually regressed back, while the blood flow remained above the baseline. Besides the sustained upregulation in blood flow, striking angiogenesis and neovascularization were observed in two out of the three high-dose VEGF-A modified RNA-injected ears (FIG. 40). The strong contrast of these neovessels in the PAM images implies that they were highly perfused with red blood cells. Specifically, as seen in FIG. 40, the neovessels appeared 14 days after the

2023208200 28 Jul 2023

injection, regressed on day 21, and “disappeared” on day 28. Similarly, in the 2nd high-dose mouse, the neovessels showed up on day 7 and “disappeared” 14 days after the injection. The “regression/disappearance” of the neovessels was likely due to the loss of blood perfusion.

[0397] To explore whether reduced VEGF-A modified RNA dosage could induce blood flow upregulation and neovascularization, the vascular responses to lower doses of VEGF-A modified RNA (30 μ g and 10 μ g) were assessed. In one mouse injected with 30 μ g VEGF-A modified RNA a less sustained upregulation in sO₂ and blood flow was induced, which regressed back to the baseline on day 14. Although capable of producing capillary angiogenesis around the injection site, pronounced neovascularization was not observed. Reducing the VEGF-A modified RNA dosage even lower (to 10 μ g) in two mice led to a further compromised vascular response (FIG. 41). Specifically, the acute upregulation in the vascular sO₂ and blood flow was slightly weaker and less sustained (regressed back to the baseline on day 7) and no notable neovascularization or angiogenesis was observed. These results further confirm the dose dependence of the vascular responses to VEGF-A modified RNA.

[0398] For comparison, the vascular responses to human recombinant VEGF-A protein were studied in three mice (FIG. 42). Similar to the high- and medium-dose VEGF-A modified RNA, the VEGF-A protein induced sustained upregulation in the local sO₂ and blood flow throughout the 7-day monitoring period. However, only very moderate capillary angiogenesis was observed in two out of the three mice on day 7 and no neovessel was observed in all cases.

2023208200 28 Jul 2023

[0399] Finally, three control experiments were performed to examine the vascular responses to citrate/saline. As shown in FIG. 43, the local sO_2 and blood flow were slightly upregulated shortly after the injection, likely due to an increase in interstitial fluid pressure, and returned to the baseline levels by day 7. No angiogenesis, neovascularization, or inflammatory response was observed.

[0400] Using vessel segmentation, the vascular responses to high-dose VEGF-A modified RNA, human recombinant VEGF-A protein, and citrate/saline were further quantitatively compared and are illustrated in FIG. 44. Acute and pronounced vasodilation and flow upregulation were observed shortly after the injection of VEGF-A modified RNA and the VEGF-A protein. Moderate responses in vessel diameter and blood flow were also observed in response to citrate/saline injection, likely a consequence of increased interstitial fluid pressure. As a response, the change from baseline (pre-injection) in vessel diameter (a mean over 4 vessels) was compared over time for the treatments and citrate/saline considered as control. The interaction between treatment and time was statistically significant ($p < 0.0001$). All treatments differed statistically from each other at 7 days ($p = 0.0009$) and VEGF-A modified RNA and human recombinant VEGF-A protein differed from saline at 6 hours ($p = 0.004$). A similar analysis was conducted for the change in volumetric flow from baseline (a mean over 4 vessels). The change in volumetric flow was compared over time for the treatments and citrate/saline considered as control. The interaction between treatment and time was statistically significant ($p = 0.02$). At day 7, VEGF-A modified RNA and human recombinant VEGF-A protein differed from citrate/saline ($p = 0.0015$). Seven days after injection, the vessel diameter and blood flow in the citrate/saline group returned back to the baseline, which

2023208200 28 Jul 2023

was in striking contrast to the sustained vasodilation and flow upregulation in the VEGF-A modified RNA and human recombinant VEGF-A protein groups.

[0401] The spatial dependence of the microvascular responses to the localized injection was further explored. To this end, all major vessels with diameters larger than 50 μm was removed using vessel segmentation and subsequently, the remaining micro vessels were divided into microsegments. Then, the microvascular sO_2 and blood flow were extended to the tissue level by superposing the values of individual micro segments. The weighting factor in the superposition was defined as the reciprocal of the distance between the centroid of the microsegment and the location of the tissue of interest. Subtracting the tissue-level flow and sO_2 maps acquired before the injection of VEGF-A modified RNA (ie, baseline) from that acquired on day 7 showed a striking (ie, ~4 fold) and spatially confined upregulation in the microvascular blood flow downstream of the injection site (FIG. 45) whereas the change in microvascular sO_2 was moderate (FIG. 45). In contrast, the VEGF-A protein-induced upregulation in microvascular flow was less pronounced and more concentrated around the injection site (FIG. 46), but the increase in microvascular sO_2 was more significant. As expected, the microvascular responses to saline injection was abolished on day 7 (FIG. 47).

[0402] Conclusions

[0403] Using multi-parametric photoacoustic microscopy and vessel segmentation, the spatiotemporal vascular responses to intradermal injection of VEGF-A modified RNA, human recombinant VEGF-A protein and citrate/saline were monitored and compared. It was demonstrated that VEGF-A modified RNA can induce dose-dependent, pronounced and sustained vasodilation, flow upregulation, capillary

angiogenesis, and neovascularization *in vivo*. Furthermore, VEGF-A modified RNA induced a striking and spatially confined upregulation in the microvascular blood flow downstream of the injection site, which was distinctly different from the highly concentrated response to the human recombinant VEGF-A protein.

6.16. EXAMPLE 16

Expression and detection of human VEGF-A protein following intradermal injection of VEGF-A modified RNA in the rabbit *in vivo*

[0404] In this experiment, the production of VEGF-A protein in rabbit skin after intradermal (id) injections of human VEGF-A modified RNA (VEGF-A modified RNA) formulated in citrate/saline was studied with microdialysis technique.

[0405] Two microdialysis probes were inserted id on the left hind leg in each of 4 anaesthetized rabbits. At t=0 hour (h), the recovery time for both microdialysis probes was started. One hour later, 4 injections of VEGF-A modified RNA (50 μ L and 50 μ g each) were given close to each microdialysis-probe. Protein-containing eluate was collected on ice every h, starting at t=2 h, for up to t=6 h. After the last eluate collection, the area surrounding the injection sites was excised.

[0406] Three hours after the injections of VEGF-A modified RNA, detectable levels (218 ± 155 , mean \pm SEM) of human VEGF-A were found in eluates from 3 out of the 8 probes. Correspondingly, at 4 and 5 hours after the injection, VEGF-A protein was detected in the eluate from 5 out of 8 and 5 out of 8 probes, respectively. Despite large variation in the concentrations observed; the protein levels tended to plateau at these time points (369 ± 217 and 360 ± 203 pg/mL, respectively).

[0407] It is concluded that human VEGF-A protein can be detected with microdialysis technique in rabbit skin three to five hours after id injection of VEGF-A modified RNA.

[0408] Compound and formulation

Test compound	Human VEGF-A modified RNA (FIG. 1B) (VEGF-A modified RNA as shown in figures accompanying Example 16)
Formulation	Citrate/saline (10 mmol/L/130 mmol/L, pH 6.5)

[0409] Test system

Species	Rabbit
Sex	Male
Total No of animals	4

[0410] Study design

Dose(s)	A total of 200 µg VEGF-A modified RNA divided by four injections at each probe-site Microdialysis probes per animal: 2
Volume(s) of administration	Four times 50 µL at each probe-site
Route(s) and frequency of administration	Intradermal
Duration of treatment	Acute
Number/group	4
Number of groups	1

[0411] Experimental procedures

2023208200 28 Jul 2023

[0412] Anaesthesia and maintenance of homeostasis: New Zealand White (NZW) male rabbits were anaesthetised with ketamine (5 mg/kg, Ketalar®, Pfizer AB, Sollentuna, Sweden) and medetomidine (0.15 mg/kg, Domitor®, Orion Pharma, Espoo, Finland) administered as an intravenous bolus injection followed by a maintenance infusion (11 and 0.33 mg/kg*h), respectively. The rabbits were intubated and artificially ventilated with a mixture of room air and 10% O₂ with a Servo ventilator (900D, Siemens Elema, Solna, Sweden). The respiratory rate was kept constant at 30 cycles/min. Before and during the experiment, the blood gases and pH in arterial blood were measured by a blood gas analyzer (ABL800 Flex, Radiometer, Copenhagen, Denmark) and, if necessary, adjusted to fall within normal physiological ranges for rabbits by adjusting the tidal volume. The rectal temperature was kept between 38 and 39.5°C by covering the animals and by external heating.

[0413] Animal preparation: A percutaneous polyethylene catheter (Venflon 0.8 mm, Viggo, Helsingborg, Sweden) for administration of anaesthetics was inserted into a marginal vein on the left ear. A polyethylene catheter (Intramedic PE-90 Clay Adams, Becton Dickinson, Sparks, MD, USA) was inserted into the right carotid artery for arterial blood pressure recording (by means of a pressure transducer, Peter von Berg Medizintechnik GmbH, Kirchseeon/Englharting, Germany) and for blood sampling, respectively. Signals from blood pressure measurements were recorded and sampled by using a computer and software (PharmLab V6.6, AstraZeneca R&D Mölndal, Sweden). The fur on the left hind leg was removed with an electric razor.

[0414] Microdialysis: Two 100 kDa linear microdialysis probes, named A and B in each experiment, (66 linear catheter & 66 high cut off linear catheter, M Dialysis AB,

2023208200 28 Jul 2023

Hammarby, Stockholm, Sweden) were inserted id on the upper part of the left hind leg of the rabbit according to the instructions provided by the supplier. The microdialysis probes were perfused with 0.5 μ L/min physiological saline (9 mg/mL, Fresenius Kabi AG, Bad Homburg, Germany) and the eluate samples were collected on ice in pre-weighed 0.5 mL tubes (Protein LoBind, Eppendorf AG, Hamburg, Germany). Dead space between the dialysis membrane and the collection tube outlet was about 1.5 μ L. The volume of each eluate was determined and 2% bovine serum albumin (BSA, A7979, Sigma-Aldrich, St. Louis, MO, USA) in phosphate buffered saline (PBS pH 7.4, gibco® by life technologies™, Paisley, UK) was added at 1:1 conditions. The samples were stored at -80°C until analyzed.

[0415] Experimental protocol: The experimental design is illustrated in FIG. 48A. At t=0 h, the recovery period for both microdialysis probes was started. One hour later (ie, t=1 h), recovery eluate was collected and subsequently 4 injections at the microdialysis-probe sites were carried out as depicted in FIG. 48B. Protein-containing eluate was collected every hour from t=2 h to t=6 h and handled as described above. At study end the animals were terminated by a lethal iv dose of pentobarbital sodium (Allfatal vet, Omnidea AB, Stockholm, Sweden).

[0416] Assessment of human VEGF-A protein in microdialysis eluates: The Gyrolab platform was used for determination of expressed human VEGF-A concentrations in microdialysis eluate samples. The Gyrolab uses an affinity flow-through format with microstructure wells (Gyros, Uppsala, Sweden). A Gyrolab bioaffy 1000 CD consisting of 96 microstructure wells containing an affinity capture column with streptavidin coated material (Gyros) was used. First, a biotinylated capture

2023208200 28 Jul 2023

polyclonal antibody against human VEGF A (AF-293-NA, R&D systems, Abingdon, UK) was immobilized on the streptavidin column, where samples are flowed through by rotation gravity and the analyte is captured on the antibodies. An Alexa-labelled detection antibody against human VEGF-A (R&D systems) was then flowed through the column and the fluorescence intensity was used for quantification of the ligand. A standard curve was created using a five parametric linear fit and the sample concentrations were calculated from the standard curve according to their absorbance. A standard curve ranging from 16.7 pg/mL to 12170 pg/mL was prepared with human VEGF-A165 (293-VE-010, R&D systems) in MSD diluent 9 (Meso Scale Discovery, Rockville, Maryland, USA). Quality controls were prepared from the WHO standard of human VEGF-A165 (National Institute for Biological Standards and Control, Hertfordshire, UK) in MSD diluent 9. All standard, QCs, and samples were mixed 1:1 with REXXIP HN-max (Gyros) before analysis.

[0417] Data analysis: Results are presented as mean±SEM.

[0418] Results

[0419] The individual human VEGF-A protein levels from the four rabbits (with two inserted probes each, A and B) are presented as mean ± SEM in FIG. 49. Three hours after the injections of VEGF-A modified RNA, detectable levels (218 ± 155 , mean ± SEM) of human VEGF-A were found in eluates from 3 out of the 8 probes. Correspondingly, at 4 and 5 hours after the injection, VEGF-A protein was detected in the eluate from 5 out of 8 and 5 out of 8 probes, respectively. Despite large variation in the concentrations observed, the protein levels tended to plateau at these time points (369 ± 217 and 360 ± 203 pg/mL, respectively).

[0420] Conclusion

[0421] Human VEGF-A protein, detected with microdialysis technique, is expressed in rabbit skin 3 to 5 hours after intradermal injection of VEGF-A modified RNA.

6.17. EXAMPLE 17

Effects on capillary and arteriole density and fibrosis following intracardiac injection of human VEGF-A modified RNA in pigs subjected to myocardial infarction *in vivo*

[0422] The assessments of the effects of VEGF-A modified RNA (1 or 10 mg), citrate/saline (2 mL) or sham procedure on capillary and arteriole density and fibrosis were undertaken in the Lanyu mini-pigs.

[0423] Capillary and arteriole density assay: Following study termination, tissue samples from the peri-infarct area were fixed in 4% paraformaldehyde at 4 °C for at least 24 hours and then paraffin embedded. After sectioning, deparaffinization and rehydration, antigen retrieval was performed by boiling in 10 mmol/L sodium citrate buffer (pH 6) for 10 minutes. Sections were then incubated with anti-cardiac troponin I (1:200, DSHB, Iowa, IA, USA), anti-isolectin (1:100, Invitrogen, Carlsbad, CA, USA) and SM-22 α (1:200, Abcam, Cambridge, UK) overnight. After washing three times, sections were incubated with the relevant Alexa Fluor 488 or 568 antibodies (Invitrogen). Nuclei were stained with 4',6-diamidino-2-phenylindole (DAPI, Sigma-Aldrich, St. Louis, MO, USA). After mounting, capillary and arteriole densities were calculated by manually counting and averaging from images (200x magnification) taken at three randomly selected areas along the peri-infarct region.

2023208200 28 Jul 2023

[0424] Fibrosis measurement: Samples remote from the infarct/peri-infarct areas were processed as described above for the peri-infarct area samples. Fibrosis, as a function of collagen deposition, was determined using Masson's trichrome staining. Images from three randomly selected areas were taken using bright field microscopy (200x magnification) for each section and then quantified (AxioVision, Zeiss, Munich Germany) and averaged.

[0425] Results

[0426] FIG. 50A and FIG. 50B illustrate the effects of sham procedure or injection of VEGF-A modified RNA (1 or 10 mg) or citrate/saline (2 mL) on capillary and arteriole density in the peri-infarct (border) zone assessed two months following induction of myocardial infarction. As seen, the injection of VEGF-A modified RNA was associated with a dose-dependent and statistically significant increase in capillary and arteriole density vs the injection of citrate/saline.

[0427] Injection of VEGF-A modified RNA vs citrate/saline was demonstrated to statistically significantly attenuate collagen content (i.e., fibrosis) in tissue samples harvested remote from the infarcted area (FIG. 50C).

6.18. EXAMPLE 18

Time course of VEGF-A protein production following human VEGF-A modified RNA transfection *in vitro*

[0428] For investigating the time profile of human VEGF-A protein production following VEGF-A modified RNA transfection, 10,000 human aortic smooth muscle cells (hAoSMC, (Lonza, Bazel, Switzerland) or 20,000 human cardiomyocytes derived from induced-pluripotent cells (hiPS-CM, Cellular Dynamics, Madison, WI, USA) were

2023208200 28 Jul 2023

seeded into 96-well plates in smooth muscle cell basal medium supplemented with growth factors (SmGM-2, Lonza) or fully supplemented cardiomyocyte maintenance medium (Cellular Dynamics), respectively. The next day transfection was undertaken in serum-free medium and 250 ng VEGF-A modified RNA was mixed with Lipofectamine 2000 (Invitrogen, Carlsbad, CA, USA) according the manufacturer's instructions and added to the cells. Lipofectamine 2000 mixed with water was used as transfection control. Medium was replaced with fresh medium every 8th hour and human VEGF-A protein was measured in the supernatant with ELISA at different time points.

[0429] The magnitude of the human VEGF-A protein produced from the VEGF-A modified RNA peaked at approximately 8 hours post-transfection in both human aortic smooth muscle cells and in human cardiomyocytes and then declined towards low levels (FIG. 51). At 32 hours post transfection, no or very low levels of protein were detected.

6.19. EXAMPLE 19

Time course of epicardium-derived cell expansion post-myocardial infarction in the mouse

[0430] Male C57BL/6 mice were anaesthetized with isoflurane, intubated and connected to a ventilator and artificially ventilated with 2.5 to 3% isoflurane supplemented with air and oxygen (80/20%). Rectal temperature was maintained at 37.5°C by a heated operation table and a heating lamp. Subsequently, the chest was shaved and ECG needle electrodes inserted in the paws for assessment of heart rate and ECG. An incision was made in the skin, the chest muscles carefully separated and the fourth intercostal space opened for chest retractor insertion. The pericardium was gently dissected and a 7-0 silk ligature was placed around the left anterior descending coronary

2023208200 28 Jul 2023

artery just under the left atrium for permanent occlusion. Ischemia was confirmed through visual inspection (paleness of the left ventricle distal from suture) and ST-elevation of the ECG. Control animals were not subjected to artery occlusion. The ribs and skin was then closed with 6-0 absorbable sutures. Analgesic (buprenorphine, 0.05 mg/kg, 10 mL/kg) was given subcutaneously and the mice were allowed to recover in its cage on an electric heating pad. The mice were sacrificed on day 3, day 7 and on day 14 post-myocardial infarction (MI). The hearts were excised and then rinsed in saline before formalin fixation. Epicardium-derived cell (EPDC) activation was assessed by Wilm's tumor protein 1 (Wt-1) expression through immunohistochemistry.

[0431] Formalin-fixated hearts were transversely sliced into 1 mm slices from apex to base. The heart slices were dehydrated in ethanol and xylene, embedded in paraffin and finally sectioned into 4 μm slices. Immunohistochemistry for Wt-1 as a marker of EPDC was carried out in a Ventana Discovery XT autostainer using rabbit polyclonal antibodies against Wt-1 (dilution 1:200, Calbiochem, San Diego, CA, USA). All reagents were Ventana products (Roche, Basel, Switzerland). Wt-1 positive (Wt-1⁺) cells were evaluated blindly and by means of a manual scoring system. The scores were defined as, 0; no Wt-1⁺ cells, 1; rare number of Wt-1⁺ positive cells, 2; few Wt-1⁺ positive cells in a single layer located at a specific level in the heart, 3; moderate number of Wt-1⁺ positive cells located at several levels in the heart and 4; extensive number of Wt-1⁺ positive cells in a thick layer located at several levels in the heart.

[0432] Few Wt-1⁺ EPDCs were found in the epicardium of control, non-infarcted hearts (FIG. 52A). Following induction of MI, the Wt-1⁺ EPDCs were activated and expanded in number reaching a peak 7 days post-MI (FIG. 52B).

2023208200 28 Jul 2023

7. SEQUENCE LISTING

7.1. SEQ ID NO: 1: Modified RNA encoding VEGF-A used in the Examples

5' ^{7Me}G_{ppp} G_{2'OMe} GGAAAUAAGAGAGAAAAGAAGAGUAAGAAGAAAUAUAAGA
 GCCACCAUGAACUUUCUGCUGUCUUGGGUGCAUUGGAGCCUUGCCUUGCU
 GCUCUACCUCACCAUGCCAAGUGGUCCCAGGCUGCACCCAUGGCAGAAAGG
 AGGAGGGCAGAAUCAUCACGAAGUGGGUGAAGUUCAUGGAUGUCUAUCAGC
 GCAGCUACUGCCAUCCAUUCGAGACCCUGGUGGACAUCUUCAGGAGUACC
 CUGAUGAGAUCGAGUACAUCUUAAGCCAUCCUGUGUGCCCCUGAUGCGA
 UGCGGGGGCUGCUGCAAUGACGAGGGCCUGGAGUGUGUGCCCACUGAGGA
 GUCCAACAUCACCAUGCAGAUUAUGCGGAUCAAAACCUCACCAAGGCCAGCA
 CAUAGGAGAGAUGAGCUUCCUACAGCACAAACAUGUGAAUUGCAGACCAA
 AGAAAGAUAGAGCAAGACAAGAAAUCCUGUGGGCCUUGCUCAGAGCGG
 AGAAAGCAUUUGUUUGUACAAGAUCGCGCAGACGUGUAAAUGUUCUGCAA
 AAACACAGACUCGCGUUGCAAGGCGAGGCAGCUUGAGUAAAACGAACGUA
 CUUGCAGAUGUGACAAGCCGAGGCGGUGAUAAUAGGCUGGAGCCUCGGUG
 GCCAUGCUUCUUGCCCCUUGGGCCUCCCCCAGCCCCUCCUCCCCUUCUGC
 ACCCGUACCCCGUGGUCUUUGAAUAAAGUCUGAGUGGGCGGCAAAAAAA
 AA
 AAUCUAG_o
 H^{3'} (SEQ ID NO: 1)

Where:

A, C, G & U= AMP, CMP, GMP & N1-methyl-pseudoUMP, respectively
 Me = methyl
 p = inorganic phosphate

7.1. SEQ ID NO: 2: Amino acid sequence of human VEGF-A isoform VEGF-

165

MNFLLSVHWSLALLLYLHHAKWSQAAPMAEGGGQNHHEVVKFMDVYQRSY
 CHPIETLVDIFQEYPDEIEYIFKPCVPLMRCGGCCNDEGLECVPTESNITMQIMR
 IKPHQGQHIGEMSFLQHNKCECRPKKDRARQENPCGPCSERRKHLFVQDPQTCK
 CSCKN TDSRCKARQLELNERTCRCDKPRR (SEQ ID NO: 2)

7.3. Luciferase mRNA Construct

Luciferase mRNA Construct (Examples 5 and 10)	
Research Target Name	Luciferase
Research Polypeptide Name	Firefly luciferase
Note: In the following mRNA sequences, A, C, G & U= AMP, CMP, GMP & N1-methyl-	

2023208200 28 Jul 2023

pseudoUMP, respectively.	
Cap	Cap, vaccinia capping enzyme
5' UTR	GGGAAAUAAGAGAGAAAAGAAGAGUAAG AAGAAAUAUAAGAGCCACC (SEQ ID NO: 3)
ORF of mRNA construct (excluding the stop codon)	AUGGAAGAUGCGAAGAACAUCAAGAAGG GACCUGCCCCGUUUUACCCUUGGAGGAC GGUACAGCAGGAGAACAGCUCCACAAGG CGAUGAAACGCUACGCCUUGGUCGCCGGA ACGAUUGCGUUUACCGAUGCACAUAUUG AGGUAGACAUCACAUACGCAGAAUACUU CGAAAUGUCGGUGAGGCUGGCGGAAGCG AUGAAGAGAU AUGGUCUUAACACUAAUC ACCGCAUCGUGGUGUGUUCGGAGAACUC AUUGCAGUUUUUCAUGCCGGUCCUUGGA GCACUUUUC AU CGGGGUCGCAGUCGCGCC AGCGAACGACAUCUACAAUGAGCGGGAA CUCUUGAAUAGCAUGGGAAUCUCCAGC CGACGGUCGUGUUUGUCUCCAAAAGGG GCUGCAGAAAUCCUCAACGUGCAGAAG AAGCUCCCCAUUAUUCAAAAGAUCAUCA UUAUGGAUAGCAAGACAGAUUACCAAGG GUUCCAGUCGAUGUAUACCUUUGUGACA UCGCAUUUGCCGCCAGGGUUUAACGAGU AUGACUUCGUCCCCGAGUCAUUUGACAG AGAUAAAACCAUCGCGCUGAUUAUGAAU UCCUCGGGUAGCACCGGUUUGCCAAAGG GGGUGGCGUUGCCCCACCGCACUGCUUGU GUGCGGUUCUCGCACGCUAGGGAUCCUA UCUUUGGUAAUCAGAUCAUCCCGACAC AGCAAUCCUGUCCGUGGUACCUUUUCAU CACGGUUUUGGCAUGUUCACGACUCUCG GCUAUUUGAUUUGCGGUUUCAGGGUCGU ACUUAUGUAUCGGUUCGAGGAAGAACUG UUUUUGAGAUCCUUGCAAGAUACAAGA UCCAGUCGGCCCUCCUUGUGCCAACGCUU UUCUCAUUCUUUGCGAAAUCGACACUUA UUGAUAAAGUAUGACCUUCCAUCUGCA UGAGAUUGCCUCAGGGGGAGCGCCGCUU AGCAAGGAAGUCGGGGAGGCAGUGGCCA AGCGCUUCCACCUUCCCGGAAUUCGGCAG GGAUACGGGCUCACGGAGACAACAUCGG CGAUCCUUAUCACGCCCAGGGUGACGA UAAGCCGGGAGCCGUCGGAAAAGUGGUC CCCUUCUUUGAAGCCAAGGUCGUAGACC UCGACACGGGAAAAACCCUCGGAGUGAA

2023208200 28 Jul 2023

	<p>CCAGAGGGGCGAGCUCUGCGUGAGAGGG CCGAUGAUCAUGUCAGGUUACGUGAAUA ACCCUGAAGCGACGAAUGCGCUGAUCGA CAAGGAUGGGUGGUUGCAUUCGGGAGAC AUUGCCUAUUGGGAUGAGGAUGAGCACU UCUUUAUCGUAGAUCGACUUAAGAGCUU GAUCAAAUACAAAGGCUAUCAGGUAGCG CCUGCCGAGCUCGAGUCAAUCCUGCUCCA GCACCCCAACAUUUUCGACGCCGGAGUGG CCGGGUUGCCCCGAUGACGACGCGGGUGA GCUGCCAGCGGCCGUGGUAGUCCUCGAAC AUGGGAAAACAAUGACCGAAAAGGAGAU CGUGGACUACGUAGCAUCACAAGUGACG ACUGCGAAGAAACUGAGGGGAGGGGUAG UCUUUGUGGACGAGGUCCCGAAAGGCUU GACUGGGAAGCUUGACGCUCGCAAAAUC CGGGAAAUCCUGAUUAAGGCAAAGAAAG GCGGGAAAUCGCUGUC (SEQ ID NO: 4)</p>
3' UTR	<p>UGAUAAUAGGCUGGAGCCUCGGUGGCCA UGCUUCUUGCCCCUUGGGCCUCCCCCAG CCCCUCUCCCCUCCUGCACCCGUACCC CCGUGGUCUUUGAAUAAAGUCUGAGUGG GCGGC (SEQ ID NO: 5)</p>
Corresponding amino acid sequence	<p>MEDAKNIKKGPAPFYPLEDGTAGEQLHKAM KRYALVPGTIAFTDAHIEVDITYAEYFEMSV RLAEAMKRYGLNTNHRIVVCSENSLOFFMP VLGALFIGVAVAPANDIYNERELLSMGSIQ PTVVVFVSKKGLQKILNVQKLPPIQKIHIMDSK TDYQGFQSMYTFVTSHLPPGFNEYDFVPESF DRDKTIALIMNSSGSTGLPKGVALPHRTACV RFSHARDPIFGNQIIPDTAILS VVPFHGHGFGM FTLGYLICGFRVFLMYRFEELFLRSLQDY KIQSALLVPTLFSFFAKSTLIDKYDLSNLHEIA SGGAPLSKEVGEAVAKRFHLPGIRQGYGLTE TTSAILITPEGDDKPGAVGKVVPFFFEAKVVD LDTGKTLGVNQRGELCVRGPMIMSGYVNNP EATNALIDKDGWLHSGDIAYWDEDEHFFIV DRLKSLIKYKGYQVAPAELESILLQHPNIFDA GVAGLPDDDAGELPAAVVVLEHGKTMTEK EIVDYVASQVTTAKKLRGGVVFVDEVPKGL TGKLDARKIREILIKAKKGGKIAV (SEQ ID NO: 6)</p>
Poly(A) tail	100 nt

2023208200 28 Jul 2023

7.4. LacZ mRNA Construct

LacZ mRNA Construct (Examples 4, 8, and 10)	
Note: In the following mRNA sequences, A, C, G & U= AMP, CMP, GMP & NI-methyl-pseudoUMP, respectively.	
Nucleotide sequence (5' UTR, ORF, 3' UTR)	<pre> UCAAGCUUUUGGACCCUCGUACAGAAGC UAAUACGACUCACUAUAGGGAAAUAAGA GAGAAAAGAAGAGUAAGAAGAAUAUAA GAGCCACCAUGGCCUUGGCUGUCGUCCUG CAAAGAAGAGAUUGGGAAAUAUCCUGGAG UUACGCAACUGAAUAGACUCGCCGCACA UCCACCGUUCGCGUCCUGGCGAAAUAAGCG AAGAAGCGCGGACCGACAGACCUUCGCA GCAGCUGCGCUCUCUCAACGGGGAAUGG CGGUUCGCAUGGUUUCGGCUCUCUGAGG CAGUCCCGGAAAGCUGGCUCGAGUGCGA CCUCCCGGAAGCCGAUACGGUGGUGGUG CCGUCAAAUUGGCAAUUGCAUGGAUACG ACGCCCCCAUCUACACCAACGUCACUAC CCUAUCACCGUGAAUCCCCCAUUCGUCCC GACUGAGAACCCGACUGGAUGCUACAGC CUGACCUUUAACGUGGACGAGUCGUGGC UGCAAGAAGGGCAGACUCGCAUCAUUU CGACGGAGUCAACUCCGCGUCCAUCUUU GGUGUAACGGACGGUGGGUGGGAUACGG GCAGGACUCCAGGCUGCCGAGCGAAUUC GACUUGUCAGCCUCCUGCGCGCCGGCGA AAACCGCCUGGCUGUCAUGGUCCUUAGA UGGUCGGAUGGCUCGUACCUGGAGGAUC AGGACAUGUGGAGGAUGUCAGGGAUUU CCGGGAUGUCUCGCUGCUCCACAAGCCAA CUACCCAGAUUCCGACUUUCAUGUGGCC ACCCGCUUCAACGAUGACUUCAGCAGGGC GGUUCUGGAAGCCGAGGUGCAAUUGUGC GGAGAACUGAGGGACUACCUCGCGUGA CUGUCUCGCUCUGGCAGGGUGAAACCCA AGUGGCUUCAGGCACUGCACCGUUCGGA GGAGAAAUCAUCGACGAACGGGGAGGAU ACGCCGAUCGCGUCACCCUGCGCCUCAU GUGGAAAUAUCCGAAACUGUGGUCGGCAG AAAUCCCUAAUUGUACCGGGCCGUGGU GGAGCUGCACACCGCCGACGGAACUCUGA UCGAGGCCGAGGCAUGCGAUGUGGGAU </pre>

2023208200 28 Jul 2023

CCGCGAGGUCCGCAUCGAAAAUGGACUG
CUUCUGCUUAAUGGCAAACCGCUGCUCA
UCCGCGGAGUGAACAGACACGAGCAUCA
CCCUCUGCACGGUCAGGUCAUGGAUGAA
CAGACUAUGGUGCAAGACAUCUGCUGA
UGAAACAAAACAACUUAACGCCGUUCG
GUGCUCUCCAUUACCCUAAUCACCCGUUGU
GGUAUACCCUUGCGAUCCGGUACGGCCU
CUACGUGGUGGACGAAGCGAACAUUCGAG
ACUCACGGAAUGGUCCCUAUGAACCGCCU
CACUGACGACCCGAGGUGGCUCUCCGGCAA
UGUCGGAACGAGUGACUCGGAUGGUGCA
GAGGGACCGCAACCAUCCGUCCGUGAUA
AUCUGGUCGCUGGGGAACGAAUCUGGCC
ACGGAGCUAACCACGAUUCGCGUACCGC
UGGAUUAAGUCCGUGGACCCAAGCCGGC
CCGUCCAGUACGAAGGAGGUGGUGCUGA
UACCACUGCAACCGACAUCUUGCCCAA
UGUAUGCGCGGGUGGAUGAGGACCAACC
UUUCCCGGGUGCCAAAGUGGUCCAUC
AAGAAAUGGCUCUCGCUGCCCGGAGAAA
CGCGCCCGCUGAUCCUGUGCGAAUAUGCG
CACGCUAUGGGAAAUCACUGGGGGGAU
UUGCGAAGUACUGGCAGGCUUUUCGACA
GUACCCGAGACUCCAGGGUGGCUUCGUG
UGGGACUGGGUUGACCAGAGCCUCAUCA
AAUACGAUGAAAACGGCAACCCAUGGUC
CGCGUACGGCGGAGACUUUGGAGACACC
CCU AACGAUCGCCAGUUCUGCAUGAACG
GCCUGGUGUUCGCCGACAGAUCUCCGCAU
CCAGCCCUUACUGAGGCCUAAGCACCAACA
ACAGUUCUUCAGUUCAGACUGUCGGGG
CAAACGAUCGAAGUGACUUCCGAAUACC
UCUUCGGCAUUCGGACAACGAGUUGCU
GCACUGGAUGGUCGCCUGGAUGGAAAG
CCCCUCGCCUCCGGAGAAGUGCCGCUCGA
CGUGGCGCCGACAGGGAAAGCAGUUGAUC
GAGUUGCCGGAACUGCCACAGCCCGAGUC
AGCAGGACAGCUCUGGCUUACCGUCAGA
GUCGUGCAGCCAAAUGCCACCGCCUGGUC
GGAGGCAGGACAUUUUCAGCCUGGCAG
CAGUGGCGCCUCGCCGAGAAUCUGAGCG
UGACCUUGCCAGCAGCCUCACACGCCAUU
CCGCAUCUGACCACGUCCGAAAUGGACUU
UUGUAUCGAACUGGGGAAUAAGCGCUGG
CAGUUCAUCCGGCAAUCAGGCCUUCUGU

2023208200 28 Jul 2023

	<p>CCCAGAUGUGGAUUGGUGACAAGAAGCA GCUCCUGACCCCGCUGCGCGAUCAGUUCA CUCGCGCCCCACUUGACAACGACAUUGGC GUGAGCGAGGCCACGCGUAUCGAUCCAA ACGCUUUGGGUGGAGCGCUGGAAGGCGGC UGGCCACUAUCAGGCGGAGGCCGCGCUCC UGCAGUGUACCGCGGAUACCCUCGCAGAC GCCGUUCUGAUUACCACGGCGCAUGCCUG GCAACACCAGGGAAAGACCCUGUUUAUC AGCCGCAAAACUUACCGGAUCGAUGGCA GCGGCCAAAUGGCGAUCACUGUGGACGU CGAGGUGGCAUCAGACACUCCACACCCAG CACGGAUCGGACUCAAUUGCCAACUGGC UCAAGUGGCUGAGAGAGUCAAUUGGCUG GGCCUCGGCCCCCAAGAGAACUACCCUGA UCGGCUUACUGCCGCAUGCUUUGACCGG UGGGAUCUGCCUCUGUCGGAUUUGUACA CCCCUACGUGUCCCAUCCGAGAACGGU CUGAGAUGCGGUACUAGGGAGUUGAACU ACGGACCGCACCAAUGGAGGGGGGACUU UCAGUUCAACAUCUCAAGAUACAGCCAG CAGCAAUUGAUGGAAACCUCGCACCGGC AUCUCUUGCAUGCAGAGGAAGGGACCUG GCUGAACAUUCGAUGGAUUCCACAUGGGA AUUGGUGGGGAUGACUCCUGGUCCCCUA GCGUGUCCGCGGAACUUCAGCUGUCCGCC GGCCGGUACCACUACCAGCUCGUGUGGU GUCAAAGUGAUAAUAGGCUGGAGCCUC GGUGGCCAUGCUUCUUGCCCCUUGGGCCU CCCCCAGCCCCUCCUCCCUUCCUGCAC CCGUACCCCGUGGUCUUUGAAUAAAGU CUGAGUGGGCGGCUCUAGA (SEQ ID NO: 7)</p>
<p>ORF amino acid sequence</p>	<p>MALAVVLQRRDWENPGVTQLNRLAAHPPF ASWRNSEEARTDRPSQQLRSLNGEWRFAWF PAPEAVPESWLECDLPEADTVVPSNWQMH GYDAPIYTNVTYPITVNPPFVPTENPTGCYSL TFNVDESWLQEGQTRIIFDGVNSAFHLWCNG RWVGYGQDSRLPSEFDLSAFLRAGENRLAV MVLRWSDGSYLEQDMWRMSGIFRDVSL HKPTTQISDFHVATRFDNDFSRAVLEAEVQM CGELRDYLRVTVSLWQGETQVASGTAPFGG EIIDERGGYADRVTLRNLNVENPKLWSAEIPN LYRAVVELHTADGTLIEAEACDVGPREVRIE NGLLLLNGKPLLIRGVNRHEHHPLHGQVMD EQTMOVQDILLMKQNNFNVAVRCSHYPNHPL WYTLCDRYGLYVVDEANIETHGMVPMNRL</p>

2023208200 28 Jul 2023

	<p>TDDPRWLPAMSERVTRMVQRDRNHPSVIIW SLGNESGHGANHDALYRWIKSVDPSRPVQY EGGGADTTATDIICPMYARVDEDQPPFAVPK WSIKKWLSLPGETRPLILCEYAHAMGNSLGG FAKYWQAFRQYPRLQGGFVWDWVDQSLIK YDENGNPWSAYGGDFGDTPNDRQFCMNGL VFADRTPHPALTEAKHQQQFFQFRLSGQTE VTSEYLFRHSDNELLHWMVALDGKPLASGE VPLDVAPQGKQLIELPELPQPESAGQLWLTV RVVQPNATAWSEAGHISAWQQWRLAENLS VTLPAASHAIPHLTSEMDFCIELGNKRWF NRQSGFLSQMWIGDKKQLLTPLRDQFTRAPL DNDIGVSEATRDPNAWVERWKAAGHYQAE AALLQCTADTLADAVLITTAHAWQHQGKTL FISRKTYRIDGSGQMAITVDVEVASDTPHPA RIGLNCQLAQVAERNWLGLGPQENYPDRL TAACFDRWDLPLSDMYTPYVFPSENGLRCG TRELNYGPHQWRGDFQFNISRYSQQQLMET SHRHLLHAEEGTWLNIDGFHMGIGGDDSW PSVSAELQLSAGRYHYQLVWCQK (SEQ ID NO: 8)</p>
<p>ORF nucleotide sequence</p>	<p>AUGGCCUUGGCUGUCGUCCUGCAAAGAA GAGAUUGGGAAAAUCCUGGAGUUACGCA ACUGAAUAGACUCGCCGCACAUCCACCGU UCGCGUCCUGGCGAAAUAGCGAAGAAGC GCGGACCGACAGACCUUCGCAGCAGCUGC GCUCUCUCAACGGGGAAUGGCGGUUCGC AUGGUUUCGGCUCCUGAGGCAGUCCCG GAAAGCUGGCUCGAGUGCGACCUCCCGG AAGCCGAUACGGUGGUGGUGCCGUCAA UUGGCAAUUGCAUGGAUACGACGCCCCC AUCUACACCAACGUCACUUAACCUAUCAC CGUGAAUCCCCCAUUCGUCCCGACUGAGA ACCCGACUGGAUGCUACAGCCUGACCUUU AACGUGGACGAGUCGUGGCUGCAAGAAG GGCAGACUCGCAUCAUUUUCGACGGAGU CAACUCCGCGUCCAUCUUUGGUGUAAC GGACGGUGGGUGGGAUACGGGCAGGACU CCAGGCUGCCGAGCGAAUUCGACUUGUC AGCCUUCUGCGCGCCGGCGAAAACCGCC UGGCUGUCAUGGUCCUAGAUGGUCGGA UGGCUCGUACCUGGAGGAUCAGGACAUG UGGAGGAUGUCAGGGAUCUUCGGGAUG UCUCGCUGCUCACAAAGCCAACUACCCAG AUCUCCGACUUUCAUGUGGCCACCCGCUU CAACGAUGACUUCAGCAGGGCGGUUCUG</p>

2023208200 28 Jul 2023

GAAGCCGAGGUGCAA AUGUGCGGAGAAC
UGAGGGACUACCUCCGCGUGACUGUCUC
GCUCUGGCAGGGUGAAACCCAAGUGGCU
UCAGGCACUGCACCGUUCGGAGGAGAAA
UCAUCGACGAACGGGGAGGAUACGCCGA
UCGCGUCACCCUGCGCCUCA AUGUGGAAA
AUCCGAAACUGUGGUCGGCAGAAAUCCC
UAAUUUGUACCGGGCCGUGGUGGAGCUG
CACACCGCCGACGGAACUCUGAUCGAGGC
CGAGGCAUGCGAUGUGGGAUUCCGCGAG
GUCCGCAUCGAAA AUGGACUGCUUCUGC
UAA AUGGCAAACCGCUGCUC AUCCGCGG
AGUGAACAGACACGAGCAUCACCCGCUGC
ACGGUCAGGUCAUGGAUGAACAGACUAU
GGUGCAAGACAUCUGCUGAUGAAACAA
ACAACUUCAACGCCGUUCGGUGCUCCA
UUACCCUAAUCACCCGUUGUGGUUAUACC
UUUGCGAUCGGUACGGCCUCUACGUGGU
GGACGAAGCGAACAU CGGAGACUCACGGA
AUGGUCCUAUGAACCGCCUCACUGACGA
CCCGAGGUGGCUC CCGGCAAUGUCGGAAC
GAGUGACUCGGAUGGUGCAGAGGGACCG
CAACCAUCCGUCGGUGAUAAUCUGGUCG
CUGGGGAACGAAUCUGGCCACGGAGCUA
ACCACGAUGCGCUGUACCGCUGGAUUA
GUCCGUGGACCCAAGCCGGCCCGUCCAGU
ACGAAGGAGGUGGUGCUGAUACCACUGC
AACCGACAUCAUCUGCCCAAUGUAUGCGC
GGGUGGAUGAGGACCAACCUUUC CCGGC
GGUGCCAAAGUGGUCCAUCAAGAA AUGG
CUCUCGCUGCCCGGAGAAACGCGCCCGCU
GAUCCUGUGCGAAUAUGCGCACGCUAUG
GGAAAUUCACUGGGGGGAUUUGCGAAGU
ACUGGCAGGCUUUUCGACAGUACCCGAG
ACUCCAGGGUGGCUUCGUGUGGGACUGG
GUUGACCAGAGCCUCAUCAAAUACGAUG
AAAACGGCAACCAUGGUCCGCGUACGGC
GGAGACUUUGGAGACACCCCUAACGAUC
GCCAGUUCUGCAUGAACGGCCUGGUGUU
CGCCGACAGAACUCCGCAUCCAGCCCUA
CUGAGGCUAAGCACCAACAACAGUUCU
CCAGUUCAGACUGUCGGGGCAAACGAUC
GAAGUGACUCCGAAUACCUUCUCCGGC
AUUCGGACAACGAGUUGCUGCACUGGAU
GGUCGCCCUUGGAUGGAAAGCCCCUCGCCU
CCGGAGAAGUGCCGCU CGACGUGGCGCCG

2023208200 28 Jul 2023

CAGGGAAAGCAGUUGAUCGAGUUGCCGG
AACUGCCACAGCCCGAGUCAGCAGGACAG
CUCUGGCUUACCGUCAGAGUCGUGCAGCC
AAAUGCCACCGCCUGGUCGGAGGCAGGA
CAUAUUUCAGCCUGGCAGCAGUGGCGCC
UCGCCGAGAAUCUGAGCGUGACCUUGCC
AGCAGCCUCACACGCCAUUCCGCAUCUGA
CCACGUCCGAAAUGGACUUUUGUAUCGA
ACUGGGGAAUAAGCGCUGGCAGUUCAAU
CGGCAAUCAGGCUUCCUGUCCCAGAUGU
GGAUUGGUGACAAGAAGCAGCUCCUGAC
CCCUCUGCGCGAUCAGUUCACUCGCGCCC
CACUUGACAACGACAUUGGCGUGAGCGA
GGCCACGCGUAUCGAUCCAAACGCUUGG
GUGGAGCGCUGGAAGGCGGCUGGCCACU
AUCAGGCGGAGGCCGCGCUCUCCUGCAGUG
UACCGCGGAUACCCUCGCAGACGCCGUUC
UGAUUACCACGGCGCAUGCCUGGCAACAC
CAGGGAAAGACCCUGUUUAUCAGCCGCA
AAACUUACCGGAUCGAUGGCAGCGGCCA
AAUGGCGAUCACUGUGGACGUCGAGGUG
GCAUCAGACACUCCACACCCAGCACGGAU
CGGACUCAAUUGCCAACUGGCUCAAGUG
GCUGAGAGAGUCAAUUGGCUGGGCCUCG
GCCCCCAAGAGAACUACCCUGAUCGGCUU
ACUGCCGCAUGCUUUGACCGGUGGGAUC
UGCCUCUGUCGGAUUGUACACCCCCUAC
GUGUUCCCAUCCGAGAACGGUCUGAGAU
GCGGUACUAGGGAGUUGAACUACGGACC
GCACCAAUGGAGGGGGGACUUUCAGUUC
AACAUUCUAAGAUACAGCCAGCAGCAAU
UGAUGGAAACCUCGCACCGGCAUCUCUU
GCAUGCAGAGGAAGGGACCUGGCUGAAC
AUCGAUGGAUUCCACAUGGGAAUUGGUG
GGGAUGACUCCUGGUCCCCUAGCGUGUCC
GCGGAACUUCAGCUGUCCGCCGCGCGGUA
CCACUACCAGCUCGUGUGGUGUCAAAAG
(SEQ ID NO: 9)

THE CLAIMS DEFINING THE INVENTION ARE AS FOLLOWS

1. A modified mRNA encoding a VEGF-A polypeptide of SEQ ID NO: 2, wherein the mRNA comprises the coding region of SEQ ID NO:1.
2. A formulation comprising the modified mRNA of claim 1 and a buffer, wherein the buffer is substantially free of divalent cations, and wherein the formulation does not include a liposome, lipoplex, or lipid nanoparticle.
3. The formulation of claim 2, wherein the buffer is a citrate saline buffer, a phosphate-buffered saline (PBS) buffer or a tromethamine (THAM) buffer.
4. The formulation of claim 2 or claim 3, wherein the buffer is a citrate saline buffer.
5. The formulation of any one of claims 2-4, wherein the formulation does not include calcium.
6. The formulation of any one of claims 2-5, wherein the buffer is substantially free of calcium and magnesium.
7. The formulation of any one of claims 2-6, wherein the buffer contains no calcium or magnesium.
8. The formulation of any one of claims 2-7, further comprising a pharmaceutically acceptable excipient.
9. The formulation of claim 8, wherein the pharmaceutically acceptable excipient is a solvent, dispersion media, diluent, dispersion, suspension aid, surface active agent, isotonic agent, thickening or emulsifying agent, preservative, core-shell nanoparticles, polymer, peptide, protein, cell, hyaluronidase, or mixtures thereof.

10. The formulation of any one of claims 2-9, wherein the formulation comprises a concentration of the modified mRNA of between 0.1 and 1 $\mu\text{g}/\mu\text{L}$.
11. The formulation of any one of claims 2-9, wherein the formulation comprises a concentration of the modified mRNA of between 1 and 10 $\mu\text{g}/\mu\text{L}$.
12. The formulation of any one of claims 2-9, wherein the formulation comprises a concentration of the modified mRNA of between 10 and 50 $\mu\text{g}/\mu\text{L}$.
13. The formulation of any one of claims 2-12 for use in a method of therapy.
14. A method of treating a disease responsive to VEGF-A therapy in a subject, the method comprising administering to the subject a modified mRNA according to claim 1 or a formulation according to any one of claims 2 to 12.
15. The method according to claim 14, wherein the disease is chosen from heart failure with reduced or preserved ejection fraction, kidney disease, a disease involving skin grafting and tissue grafting, post-MI cardiac dysfunction, ischemic heart disease, a vascular injury from trauma or surgery, a skin ulcer including a diabetic ulcer, critical limb ischemia, pulmonary hypertension, and peripheral arterial disease.
16. The method according to claim 14, wherein the modified mRNA or formulation is administered to the subject via intramuscular, intradermal, subcutaneous, intracardiac, or epicardiac route, through a portal vein catheter, through a coronary sinus catheter, and/or by direct administration into the area to be treated.
17. The formulation for use according to claim 13, wherein therapy comprises inducing angiogenesis, stimulating vascular cell proliferation, increasing proliferation and/or altering the fate of epicardial derived progenitor cells, upregulating endothelialization, inducing cardiac regeneration, increasing revascularization of tissue grafts for wound healing, improving vascular function, increasing tissue perfusion and new vessel formation, reducing scar tissue, and/or improving cardiac function.

18. The formulation for use according to claim 13, wherein therapy comprises upregulating endothelialization and/or inducing cardiac regeneration.

19. The formulation for use according to claim 13, wherein the formulation is administered post myocardial infarction (MI) at peak time of epicardium-derived cell activation in the myocardium.

20. The formulation for use according to claim 13, wherein the formulation is administered 7 days post-MI, 10 days post-MI, 2 weeks post-MI, 3 weeks post-MI, or 6 weeks post-MI.

21. The formulation for use according to claim 13, wherein the formulation is administered 7 days post-MI.

22. The formulation for use according to claim 13, wherein therapy comprises treating myocardial infarction with reduced ejection fraction or treating heart failure with preserved ejection fraction.

23. The formulation for use according to claim 22, wherein the formulation is injected at the border zone between healthy and infarcted tissue.

24. A method of inducing angiogenesis, stimulating vascular cell proliferation, increasing proliferation and/or altering the fate of epicardial derived progenitor cells, upregulating endothelialization, inducing cardiac regeneration, increasing revascularization of tissue grafts for wound healing, improving vascular function, increasing tissue perfusion and new vessel formation, reducing scar tissue, and/or improving cardiac function, in a subject, the method comprising administering to the subject a modified mRNA according to claim 1 or a formulation according to any one of claims 2 to 12.

25. A method of upregulating endothelialization and/or inducing cardiac regeneration in a subject, the method comprising administering to the subject a modified mRNA according to claim 1 or a formulation according to any one of claims 2 to 12.

26. A method of treating myocardial infarction with reduced ejection fraction or treating heart failure with preserved ejection fraction in a subject, the method comprising administering to the subject a modified mRNA according to claim 1 or a formulation according to any one of claims 2 to 12.

27. Use of a modified mRNA according to claim 1 or a formulation according to any one of claims 2 to 12 in the manufacture of a medicament for treating a disease responsive to VEGF-A therapy in a subject.

28. Use of a modified mRNA according to claim 1 or a formulation according to any one of claims 2 to 12 in the manufacture of a medicament for inducing angiogenesis, stimulating vascular cell proliferation, increasing proliferation and/or altering the fate of epicardial derived progenitor cells, upregulating endothelialization, inducing cardiac regeneration, increasing revascularization of tissue grafts for wound healing, improving vascular function, increasing tissue perfusion and new vessel formation, reducing scar tissue, and/or improving cardiac function, in a subject.

29. Use of a modified mRNA according to claim 1 or a formulation according to any one of claims 2 to 12 in the manufacture of a medicament for upregulating endothelialization and/or inducing cardiac regeneration in a subject.

30. Use of a modified mRNA according to claim 1 or a formulation according to any one of claims 2 to 12 in the manufacture of a medicament for treating myocardial infarction with reduced ejection fraction or treating heart failure with preserved ejection fraction in a subject.

FIG. 1A

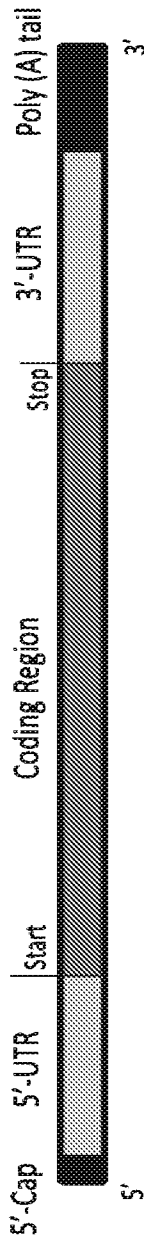

FIG. 1B

⁷Me G_{ppp} G_{2OMe} GGAAUAAGAGAGAAAGAGUAAGAAGAAUAUAAGAGCCACCAUGAACUUUCUGCUGUCUUG
 GGUGCAUUGGAGCCUUGCCUUGCUCUACCCUCCACCAUGCCAAAGUGGCCAGGCCUGCCACCCAUUGCAGAAAG
 GAGGAGGCAGAUCAUCACGGAAGUGGUAGAUCAUGGAUGUAUCAGCGCAGCUACUGCCAUCCAAUCCGAG
 ACCUGGUGGACAUCUCCAGGAGUACCCUGAUGAGAUCAUCUUAAGCCAUCCUGUGGCCCCUGAU
 GCGAUGCCGGGCGUGCAUAGCAGGCGCCUGGAGUGUGCCACUGAGGAGUCCAAACAUCACCAUGCAG
 AUUAUGCGGAUCAACCUCACCCAGCCACAUAJGGAGAUAGCUUCCUACAGCACAAACAUAUGUAAUUGC
 AGACCAAAGAAAGAUAGAGCAAGACAAGAAUCCUGGGCCUUGCCUCAGAGCGGAGAAAGCAUUUUGUA
 CAAGAUCCGCAGACGUGUAAUUGUCCUGCAAAACACAGACUCGCGUUGCAAGCGGAGGCGCUUGAGUAAAC
 GAACGUACUUGCAGAUUGACAAAGCCGAGGUGAUAAUJAGGCUUGAGCCUCGUGGCCAUUCUUGCCCCC
 UUGGGCCUCCCCAGCCUCCUCCUCCGUAACCCCGUGUCUUUGAAUAAAGUCUGAGUGGG
 CGGCAAA
 AAAAAAAAAAAAAAAAAAAAAAAAAAUCUAG_{OH} 3'

Where:
 A, C, G & U= AMP, CMP, GMP & N1-methyl-pseudoUMP, respectively
 Me = methyl
 p = inorganic phosphate

FIG. 2A

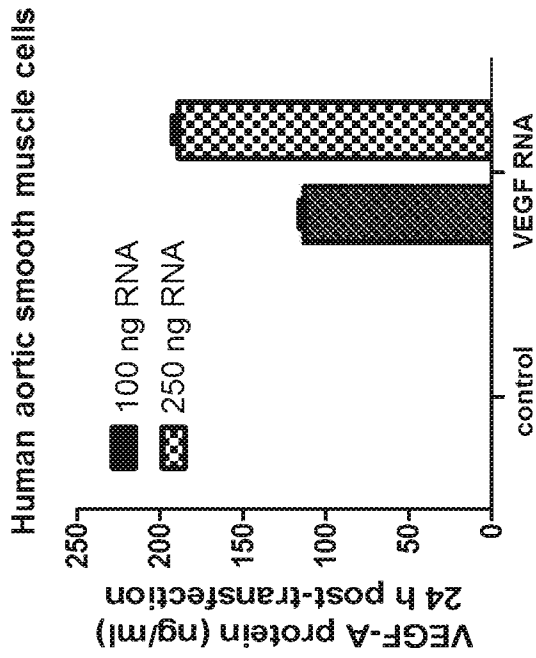

FIG. 2B

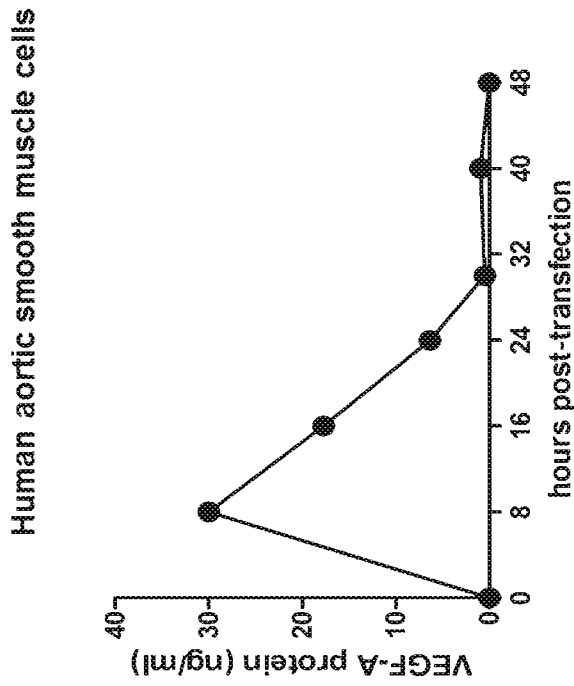

FIG. 2C

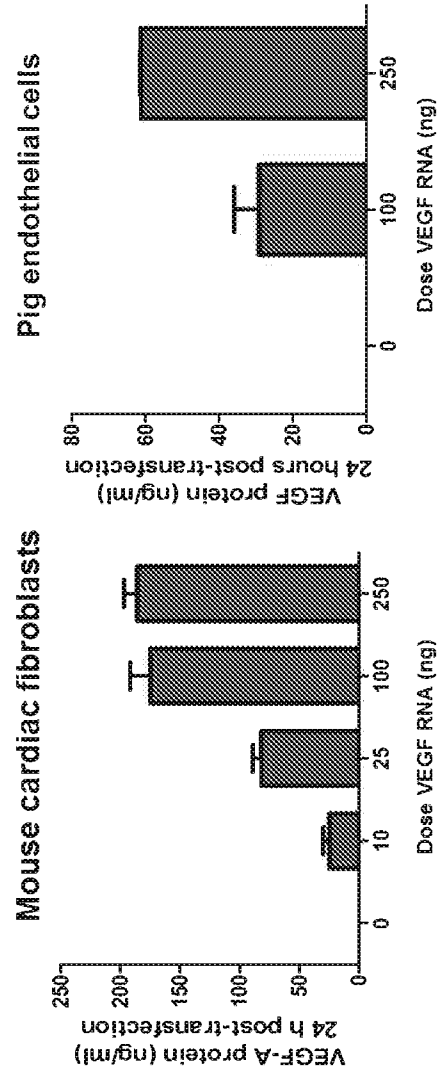

FIG. 3A

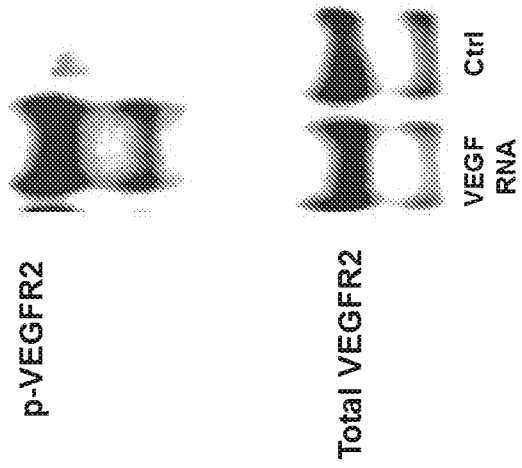

FIG. 3B

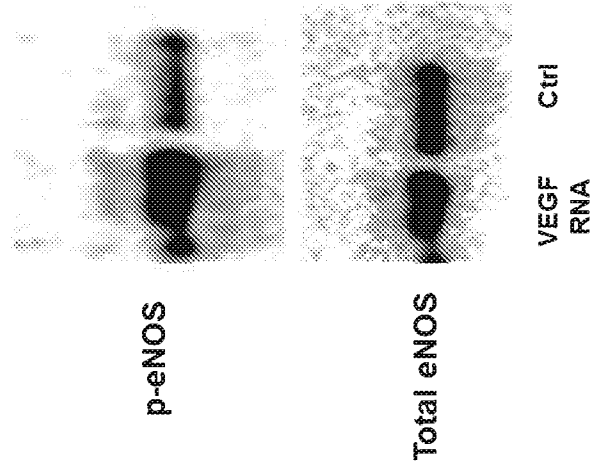
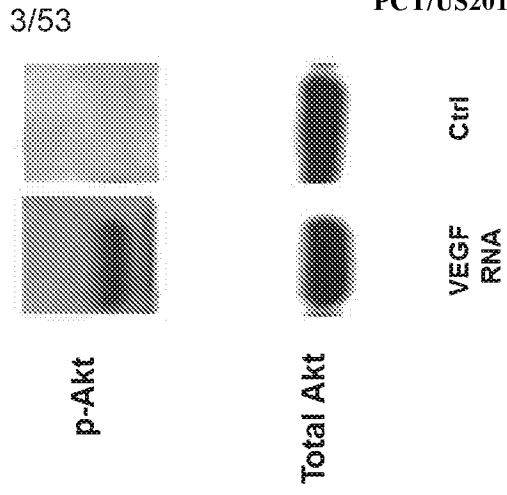

FIG. 3C



3/53

FIG. 4B

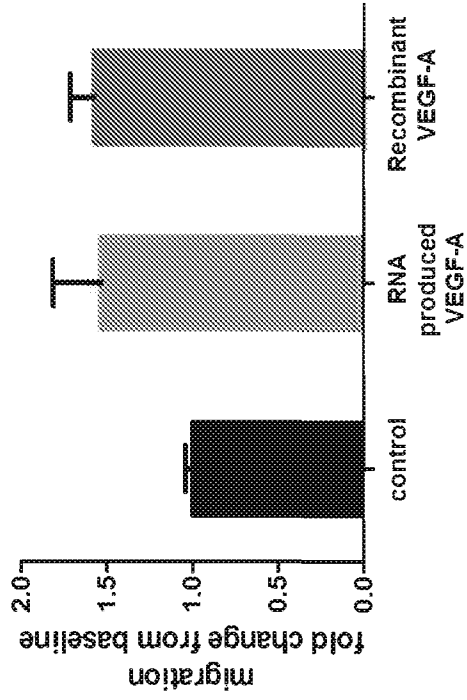

FIG. 4A

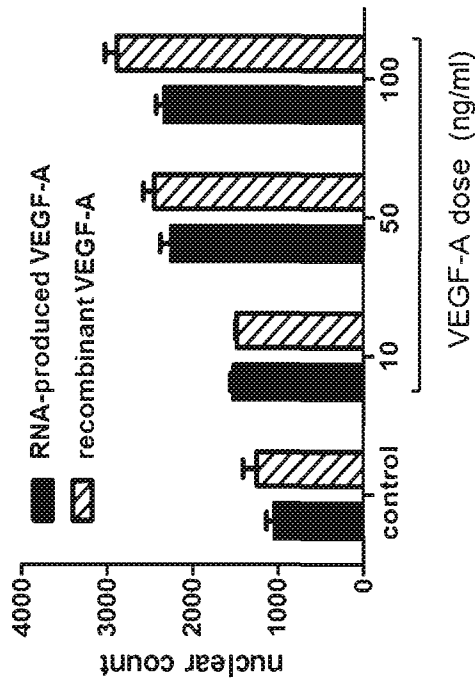

FIG. 4C

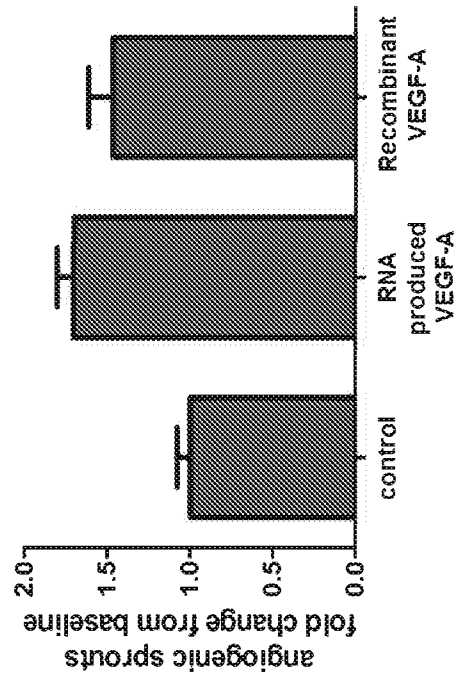
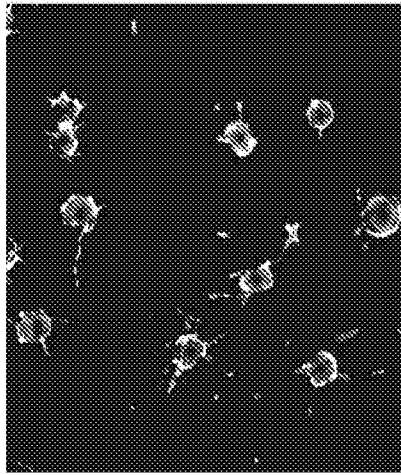
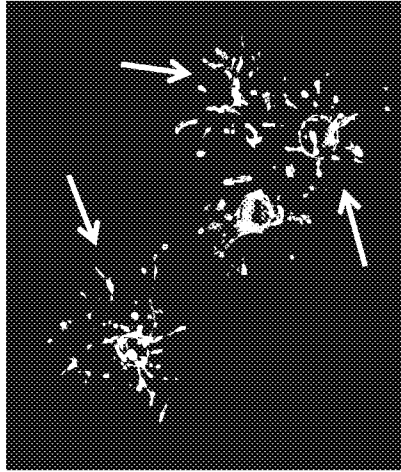

FIG. 5A



control

FIG. 5B



RNA-produced
VEGF-A

FIG. 5C

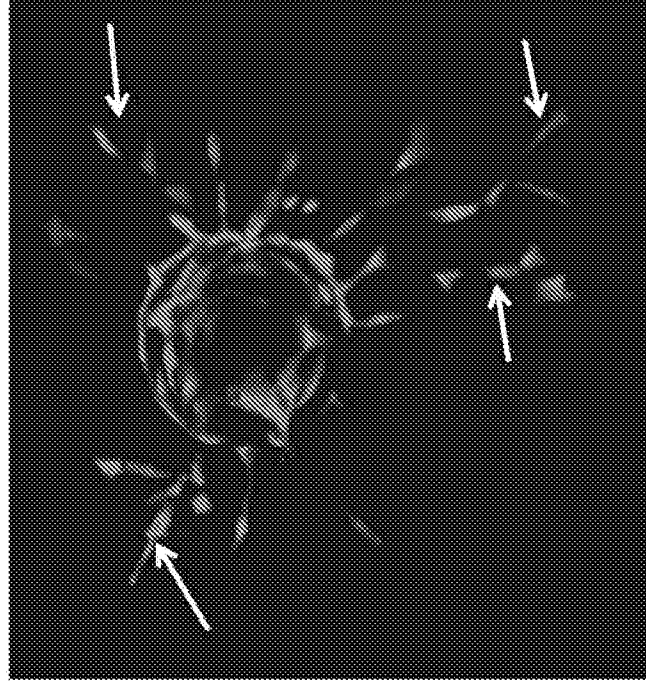

RNA-produced VEGF-A

FIG. 6C

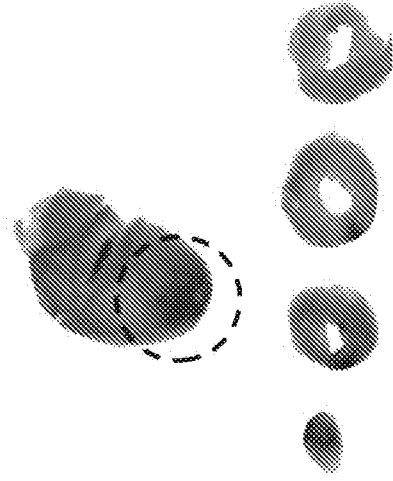

FIG. 6B

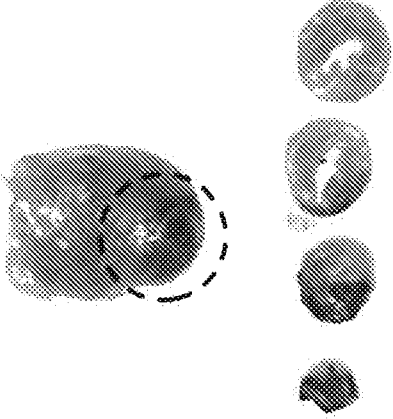
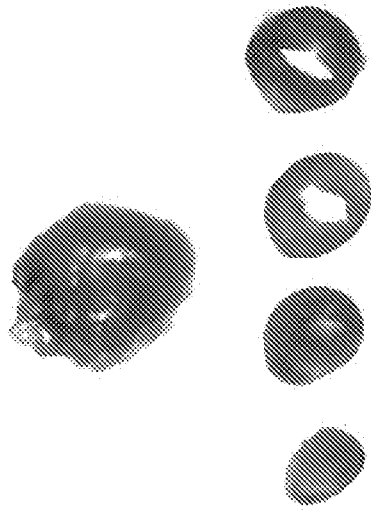

FIG. 6A



Apex

Base

2023208200 28 Jul 2023

FIG. 7

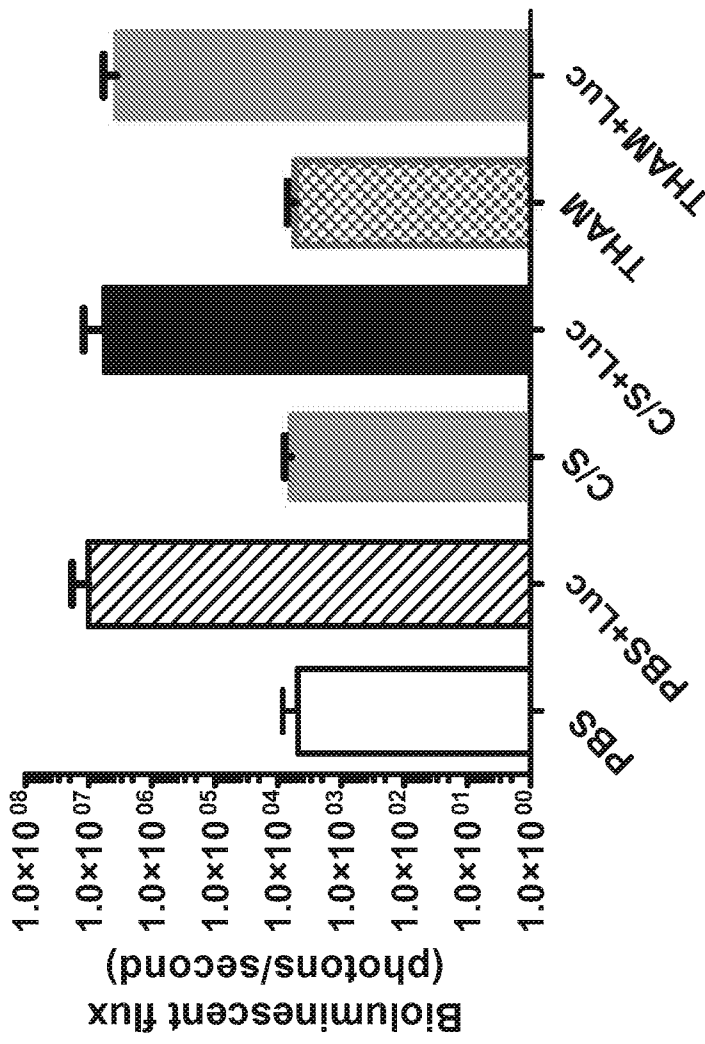

FIG. 8A

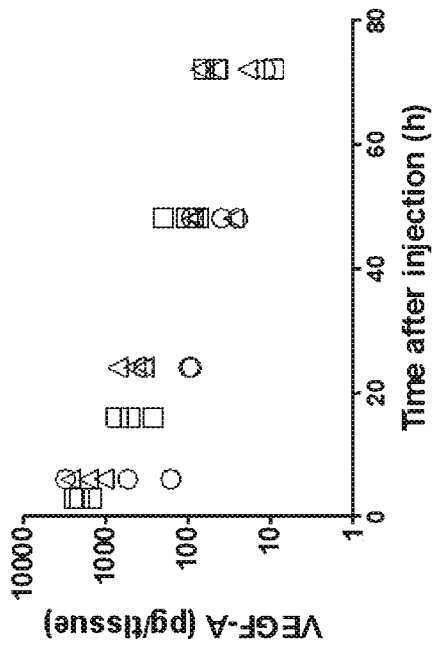

FIG. 8B

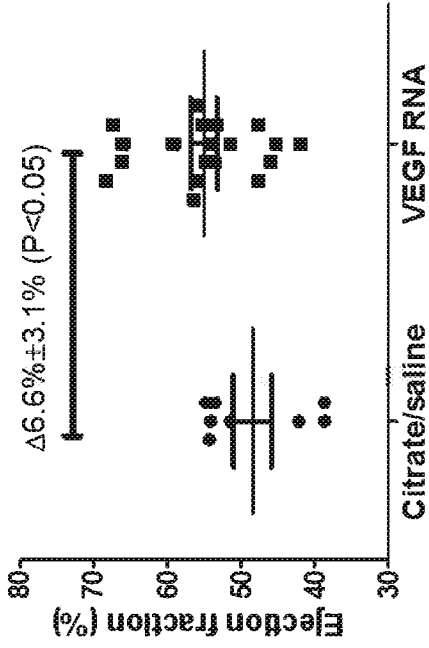

FIG. 8C

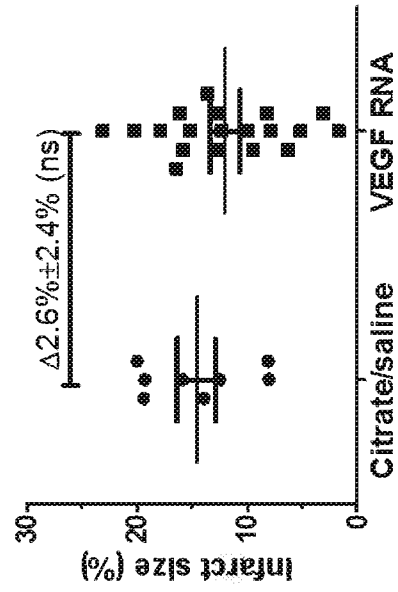

FIG. 8D

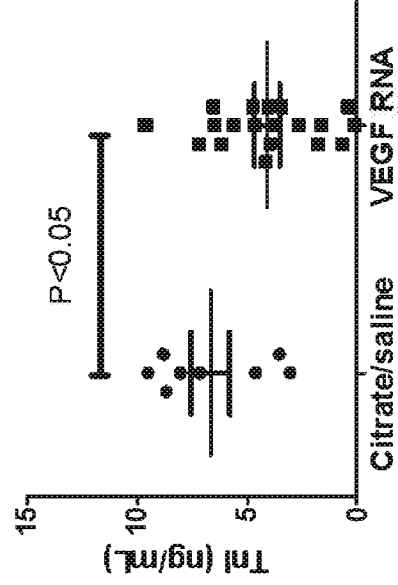

FIG. 9B

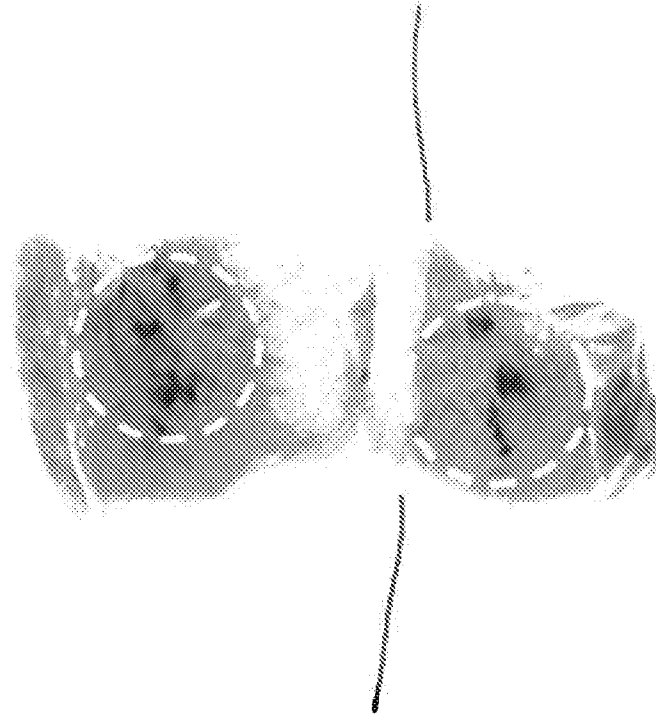

FIG. 9A



2023208200 28 Jul 2023

FIG. 10

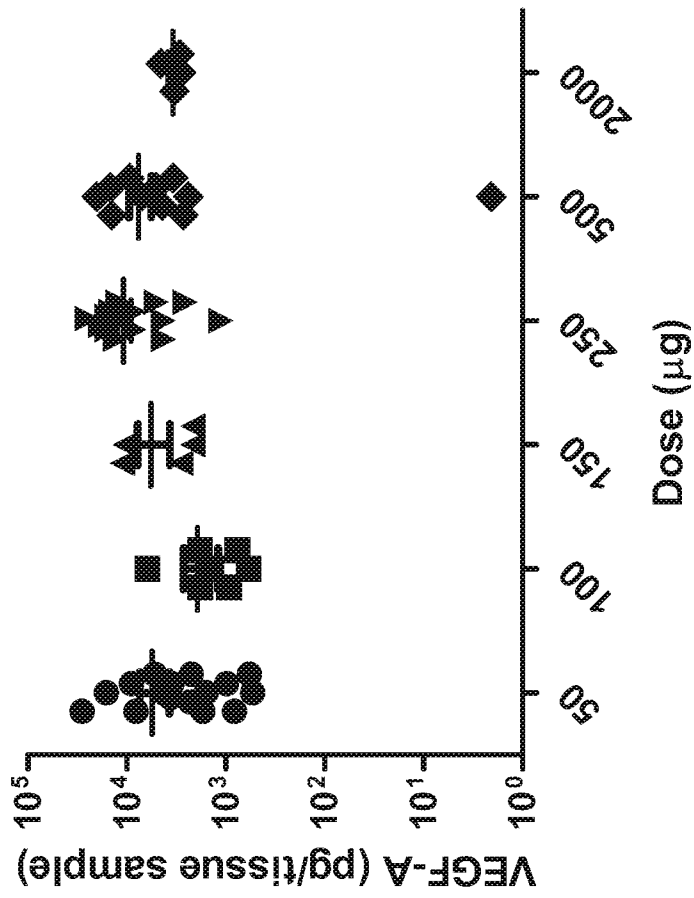

FIG. 11A

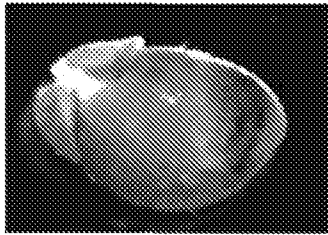

FIG. 11B



FIG. 11C

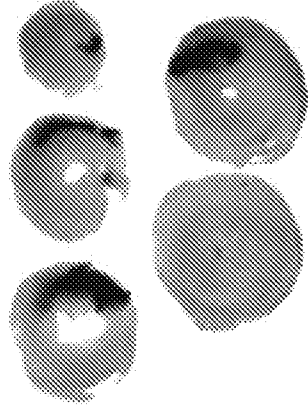

FIG. 11D

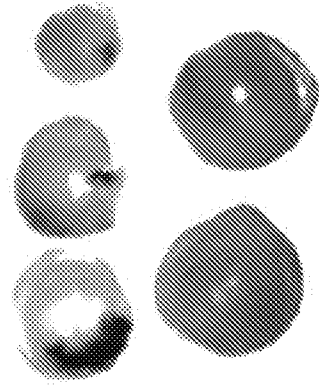

FIG. 11E

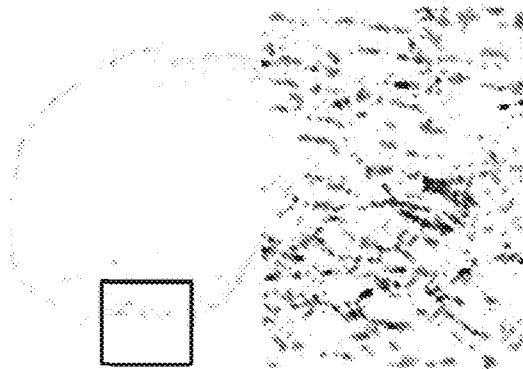

FIG. 11F

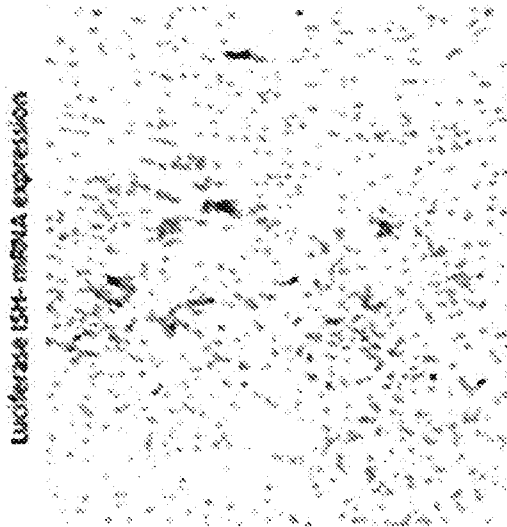

FIG. 11G

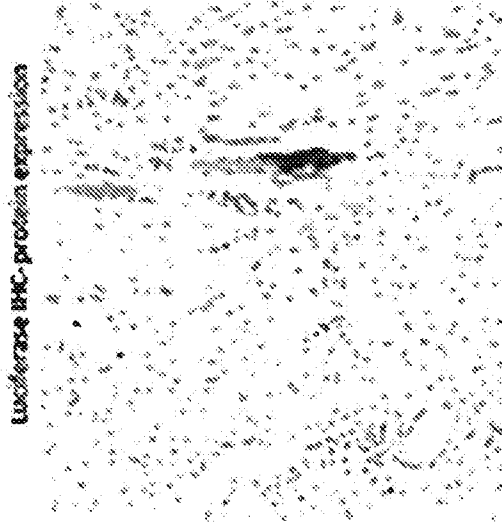

FIG. 12A

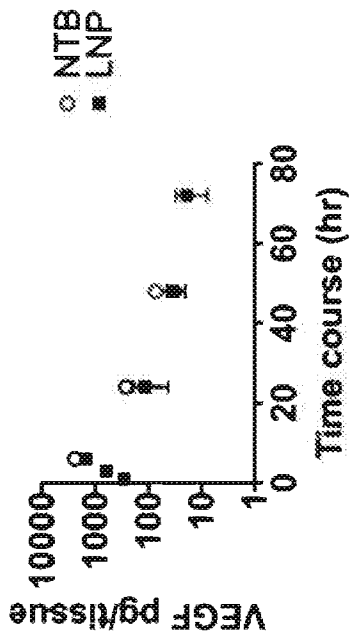

FIG. 12B

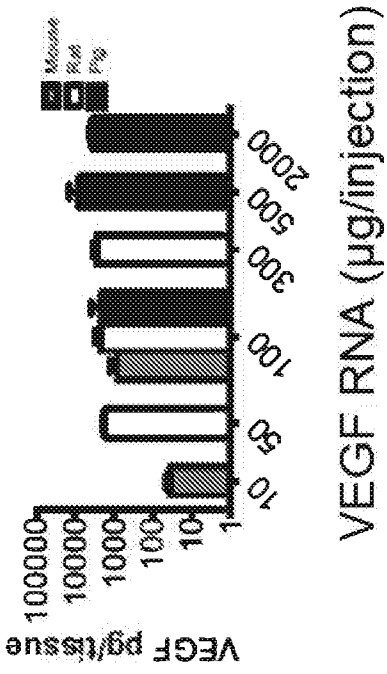

FIG. 12C

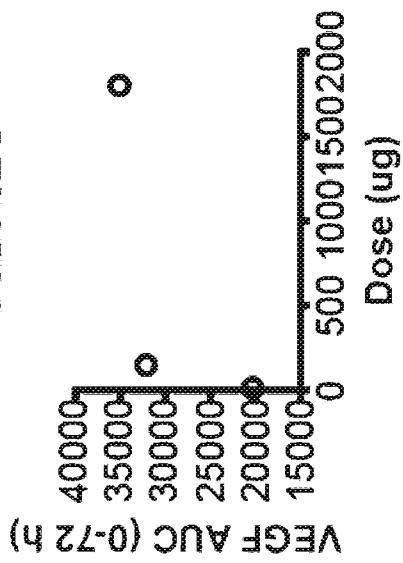

FIG. 13B

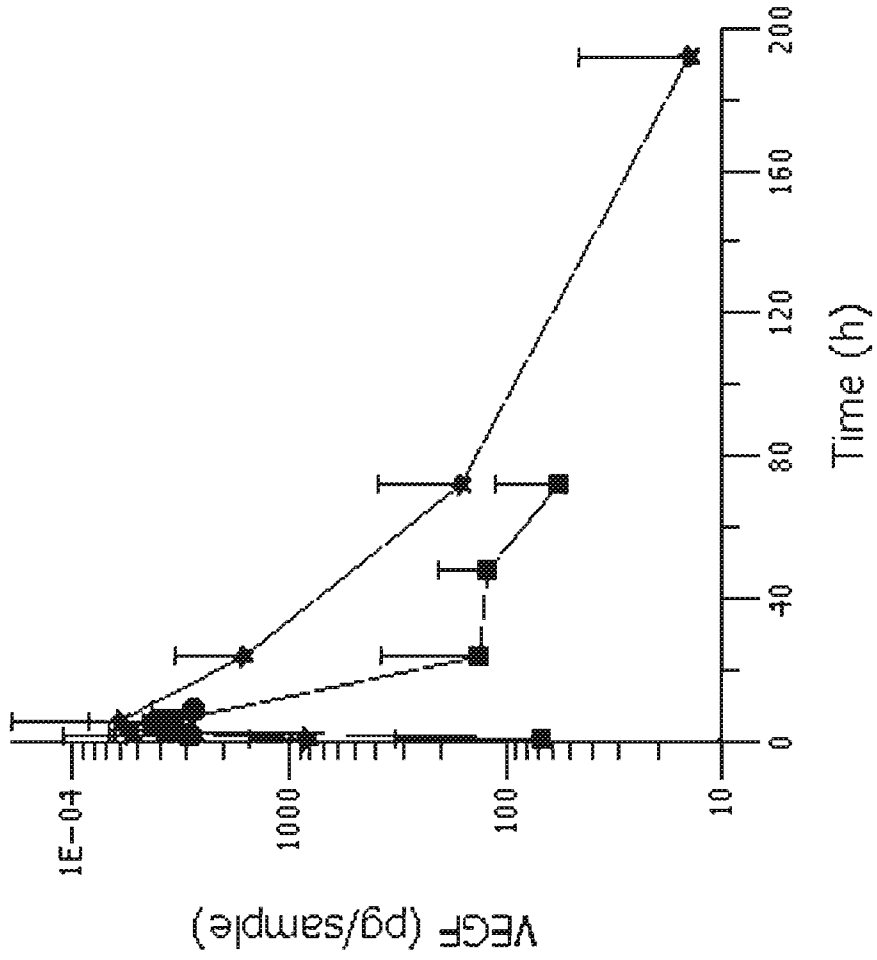
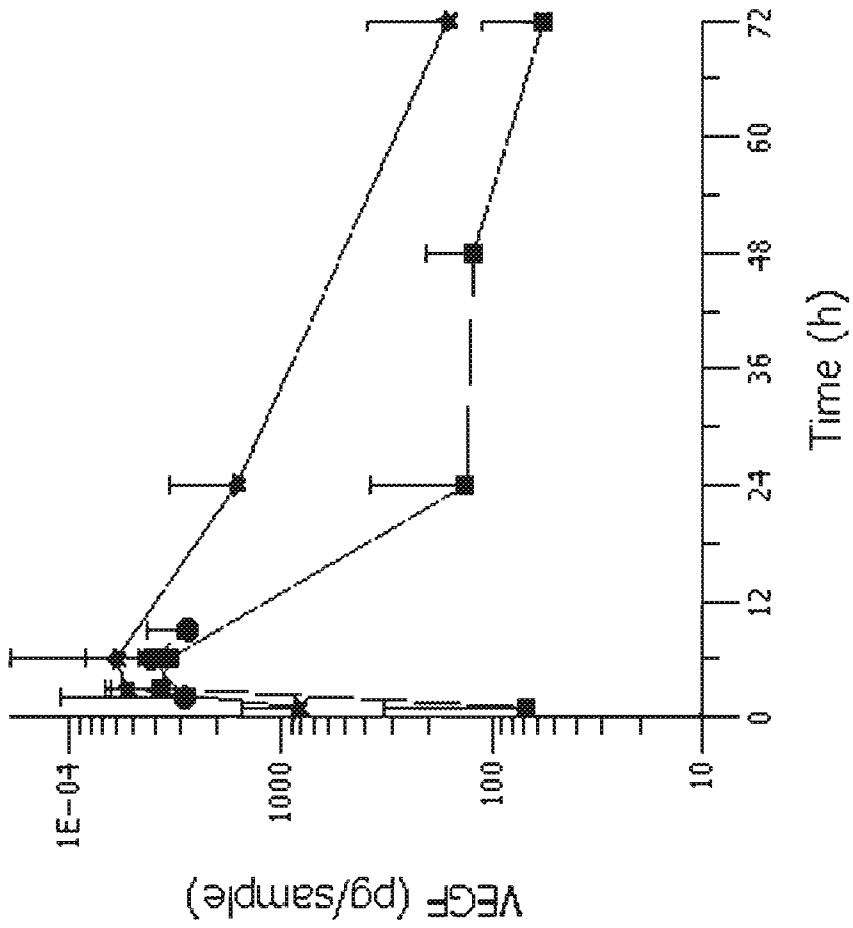
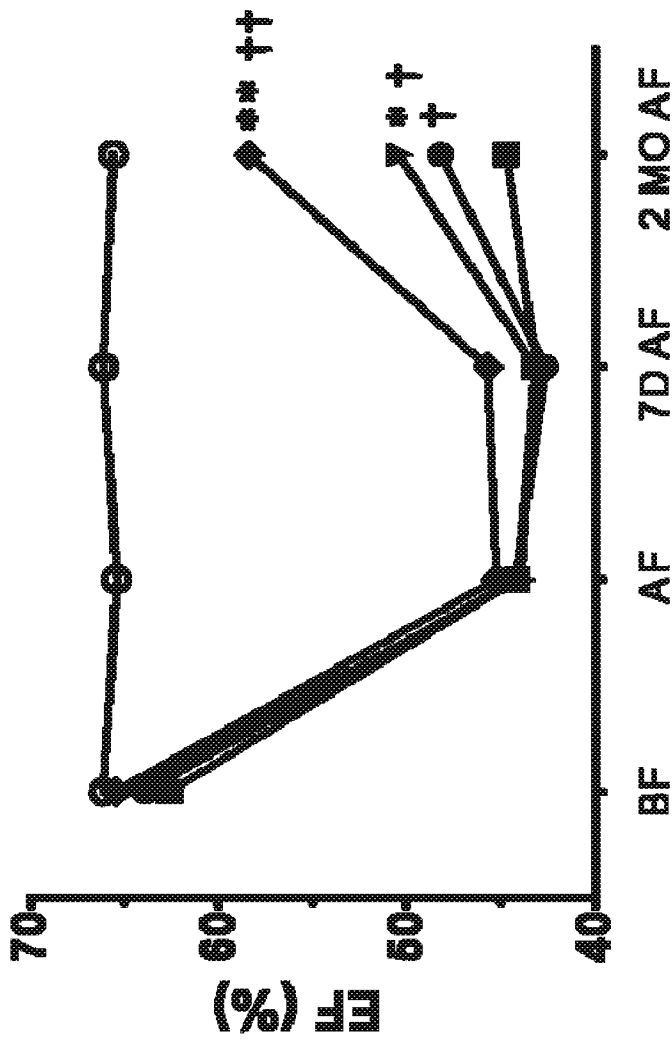

FIG. 13A



2023208200 28 Jul 2023

FIG. 14



2023208200 28 Jul 2023

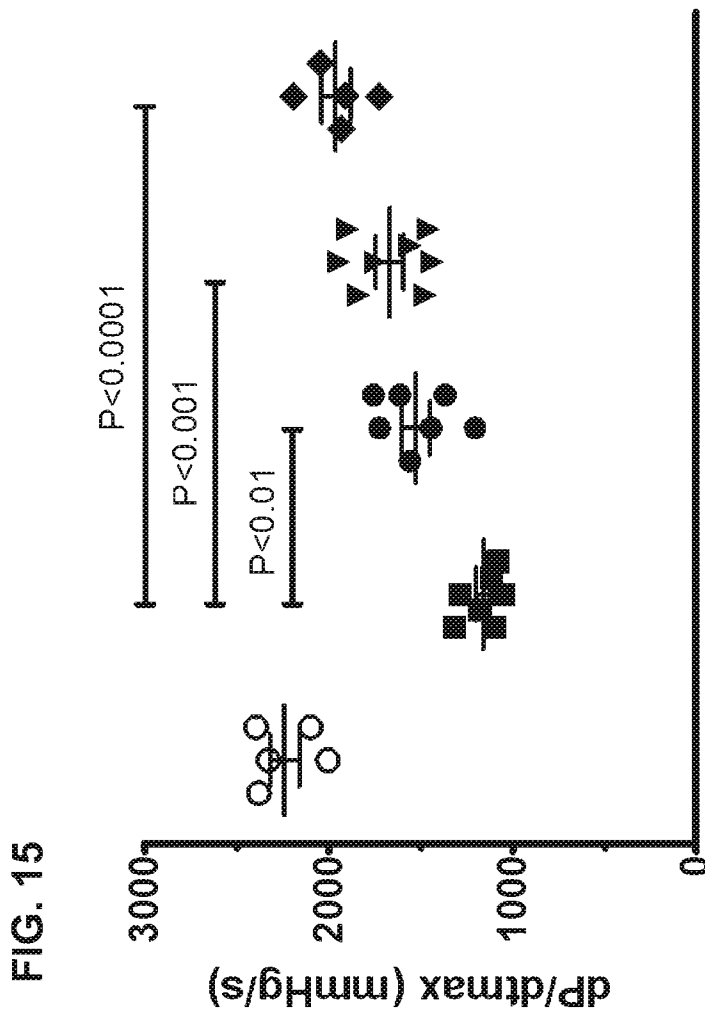

2023208200 28 Jul 2023

FIG. 16

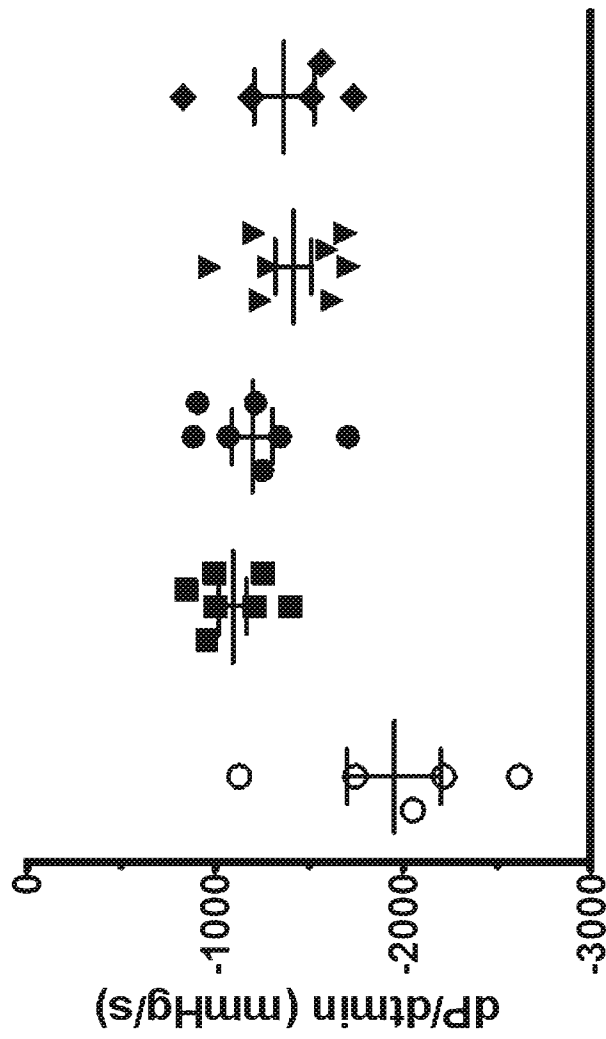

2023208200 28 Jul 2023

FIG. 17

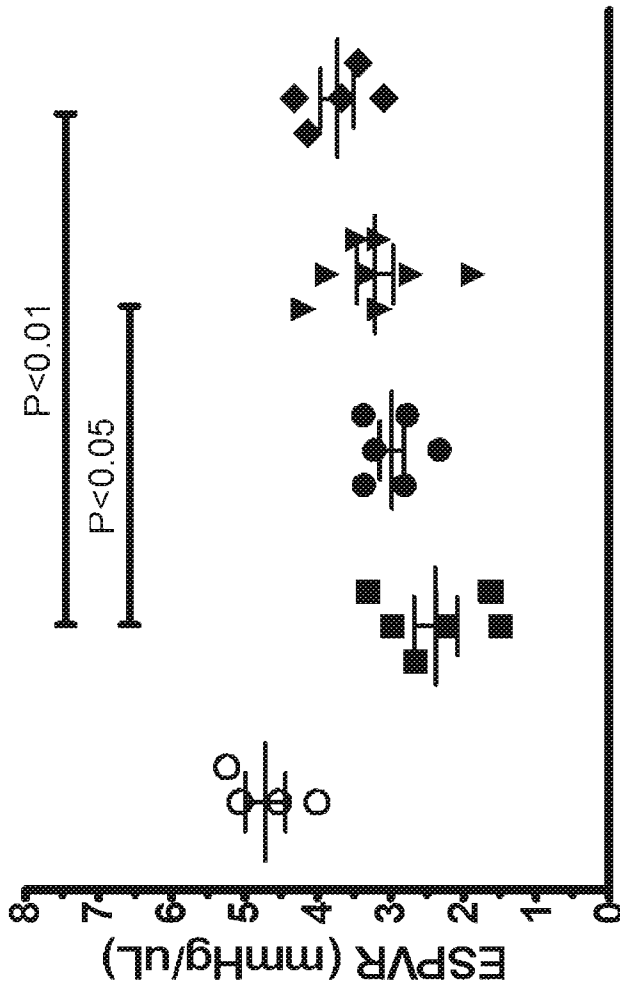

FIG. 18

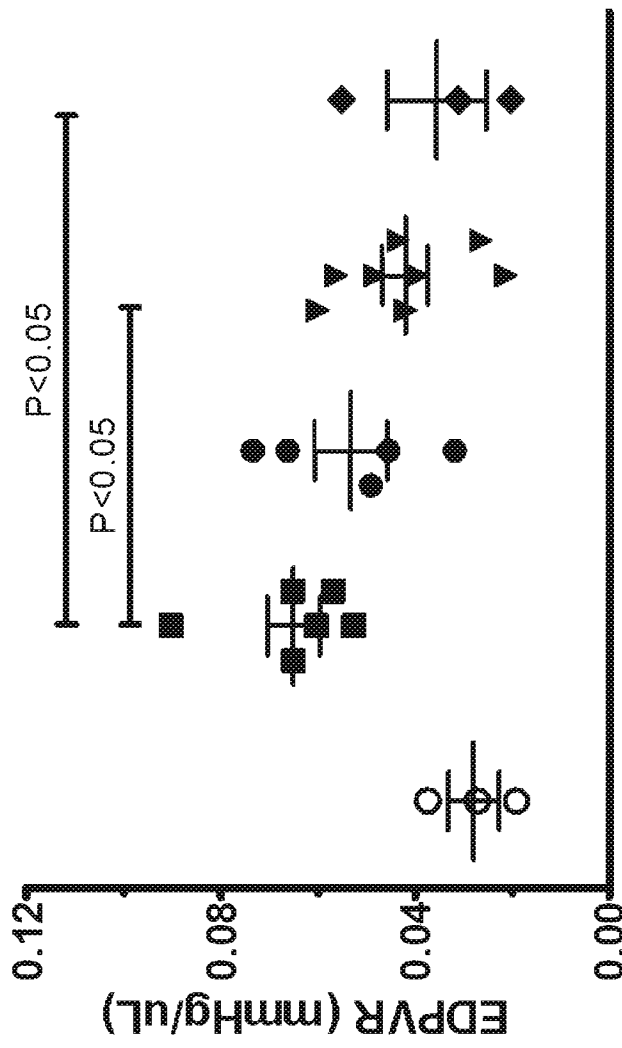
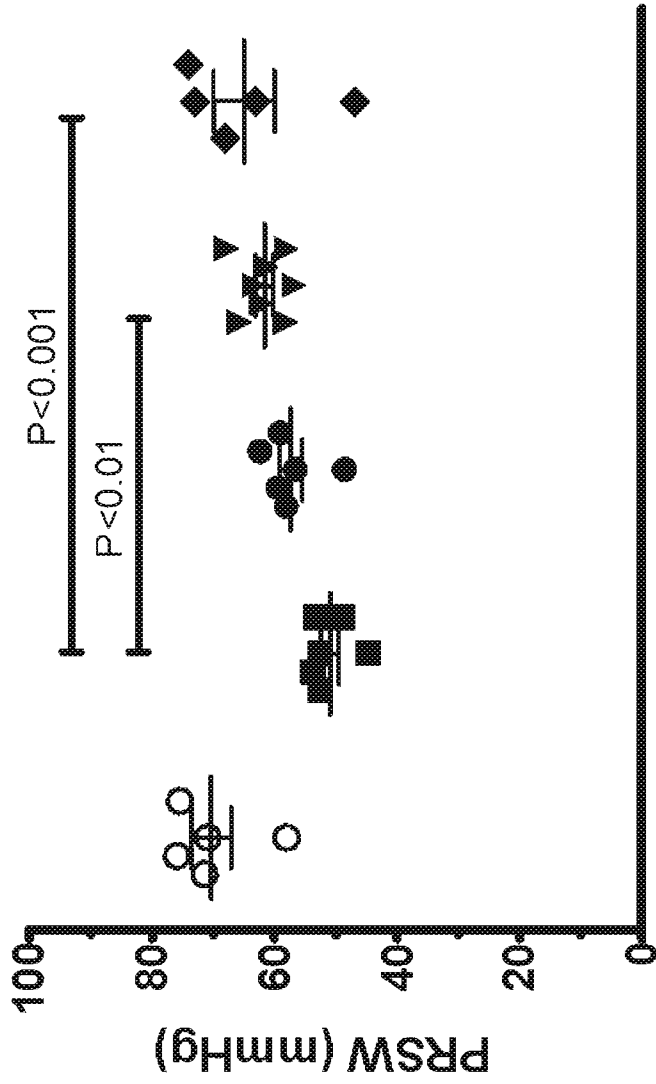

FIG. 19



2023208200 28 Jul 2023

FIG. 20A

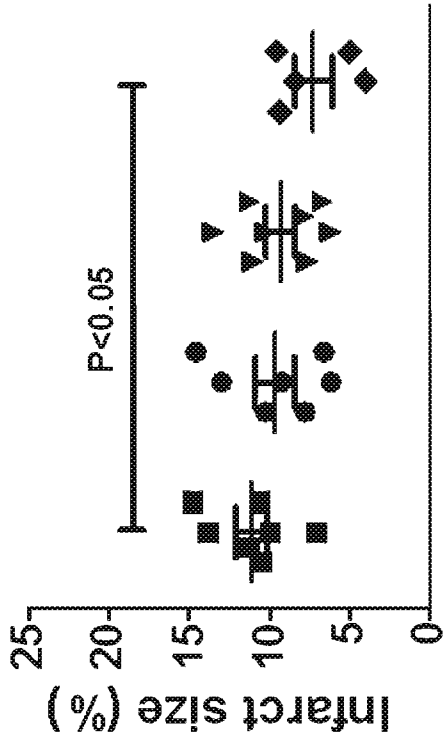

FIG. 20B

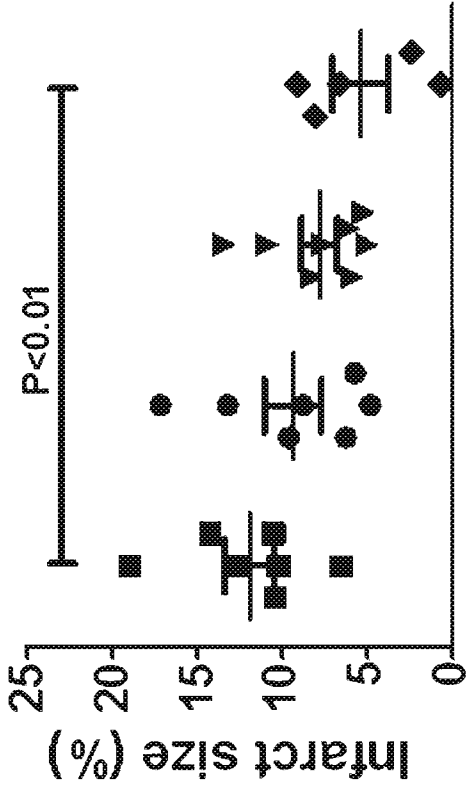
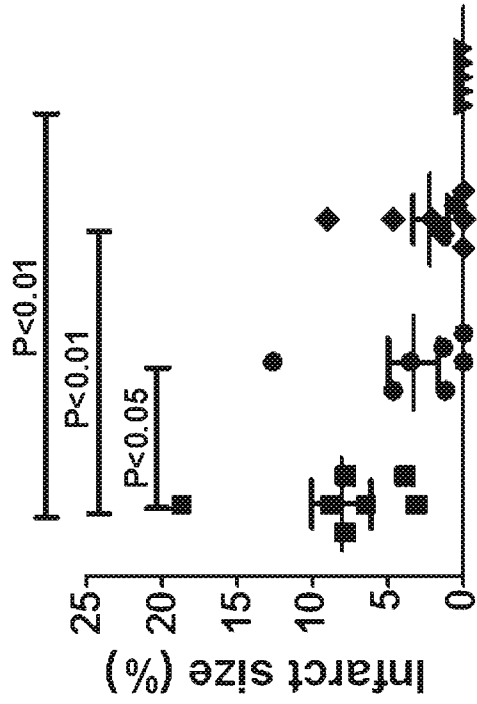
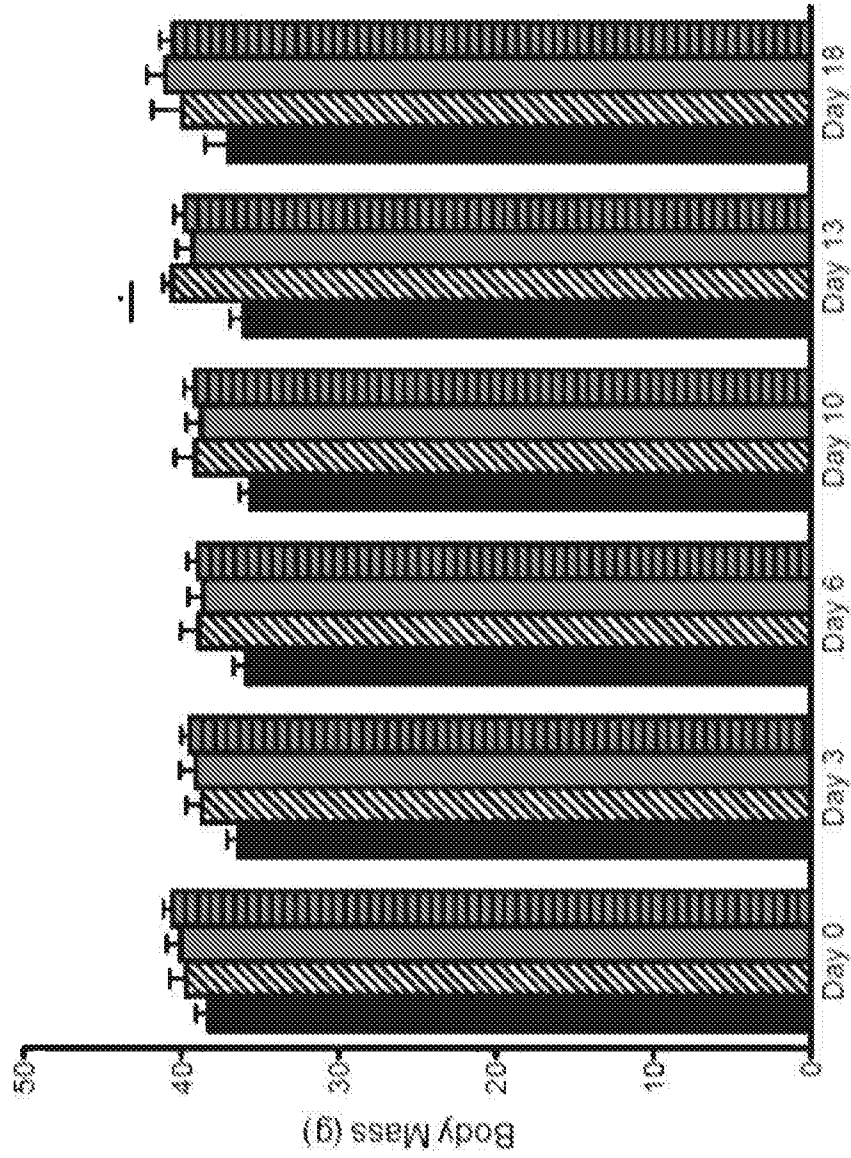

FIG. 20C



2023208200 28 Jul 2023

FIG. 21



2023208200 28 Jul 2023

FIG. 22

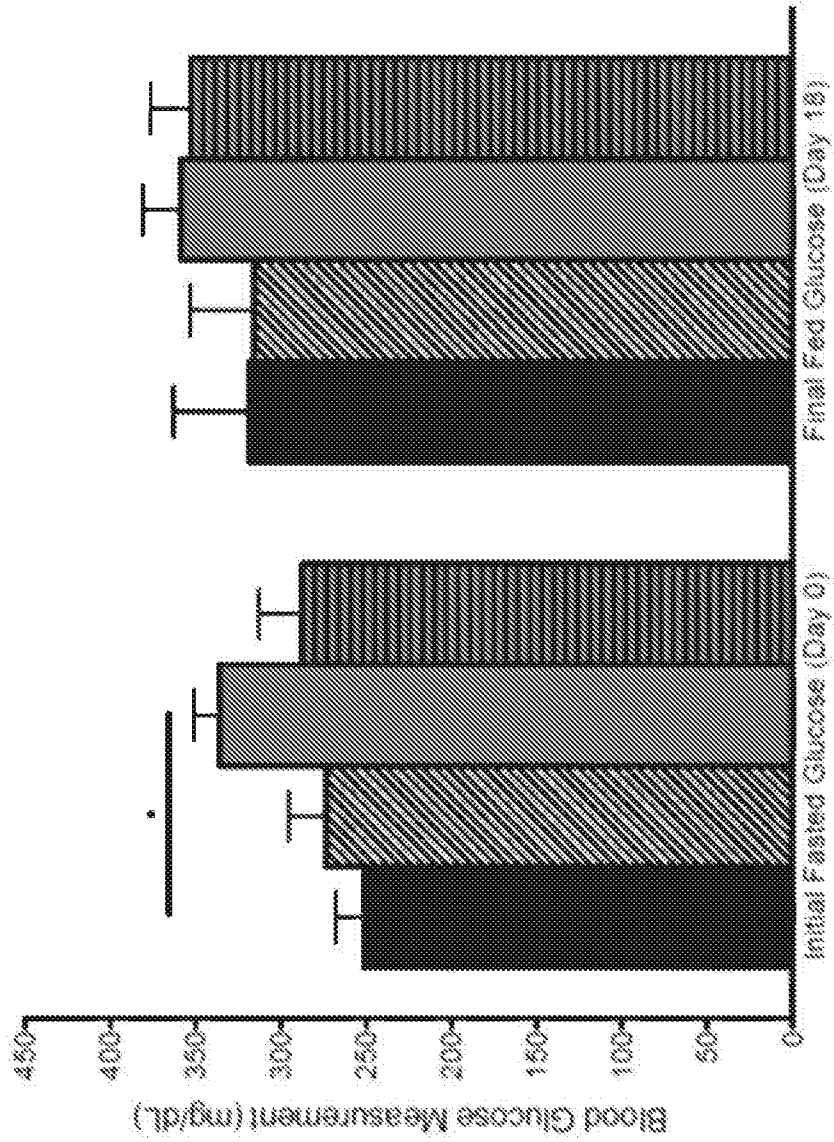

2023208200 28 Jul 2023

FIG. 23

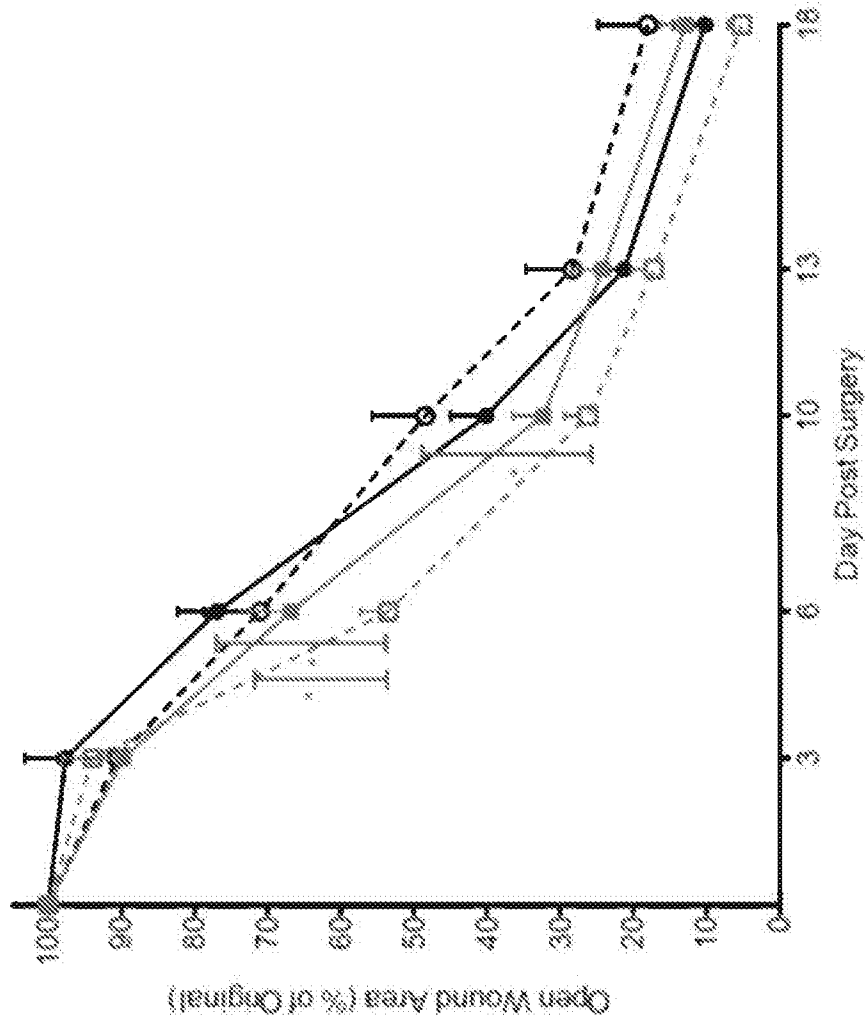

2023208200 28 Jul 2023

FIG. 24

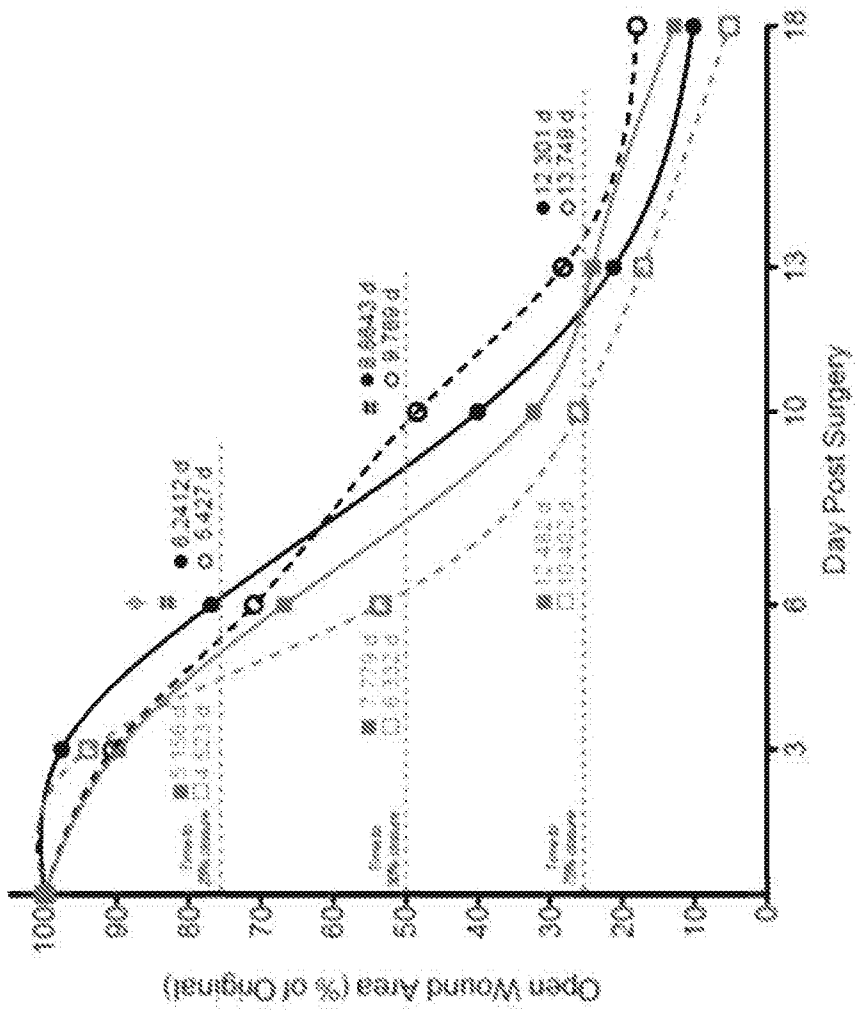

2023208200 28 Jul 2023

FIG. 25

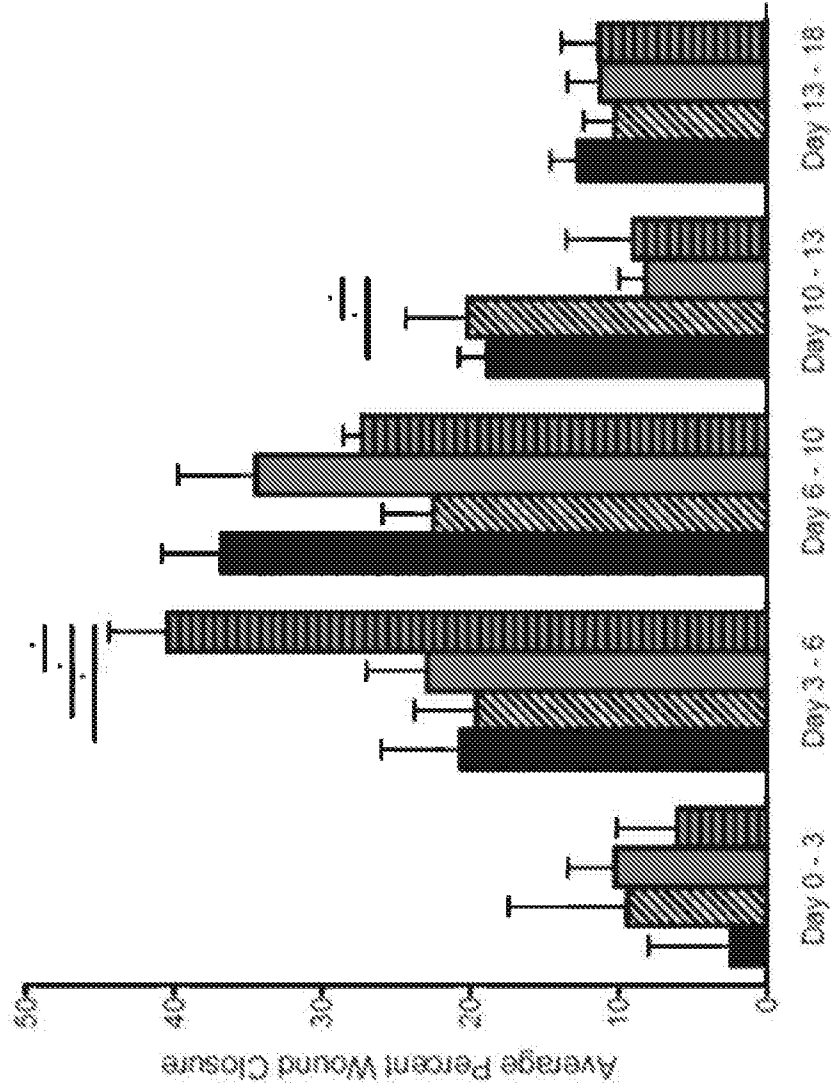

2023208200 28 Jul 2023

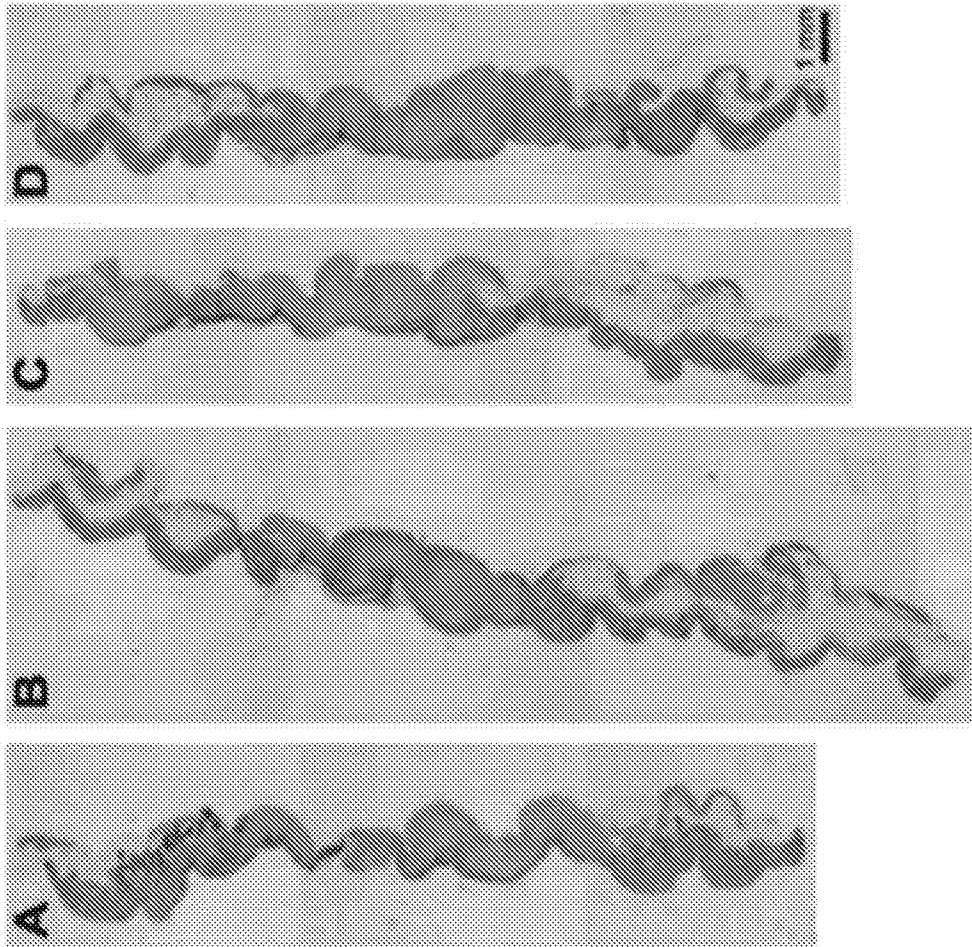

FIG. 26

2023208200 28 Jul 2023

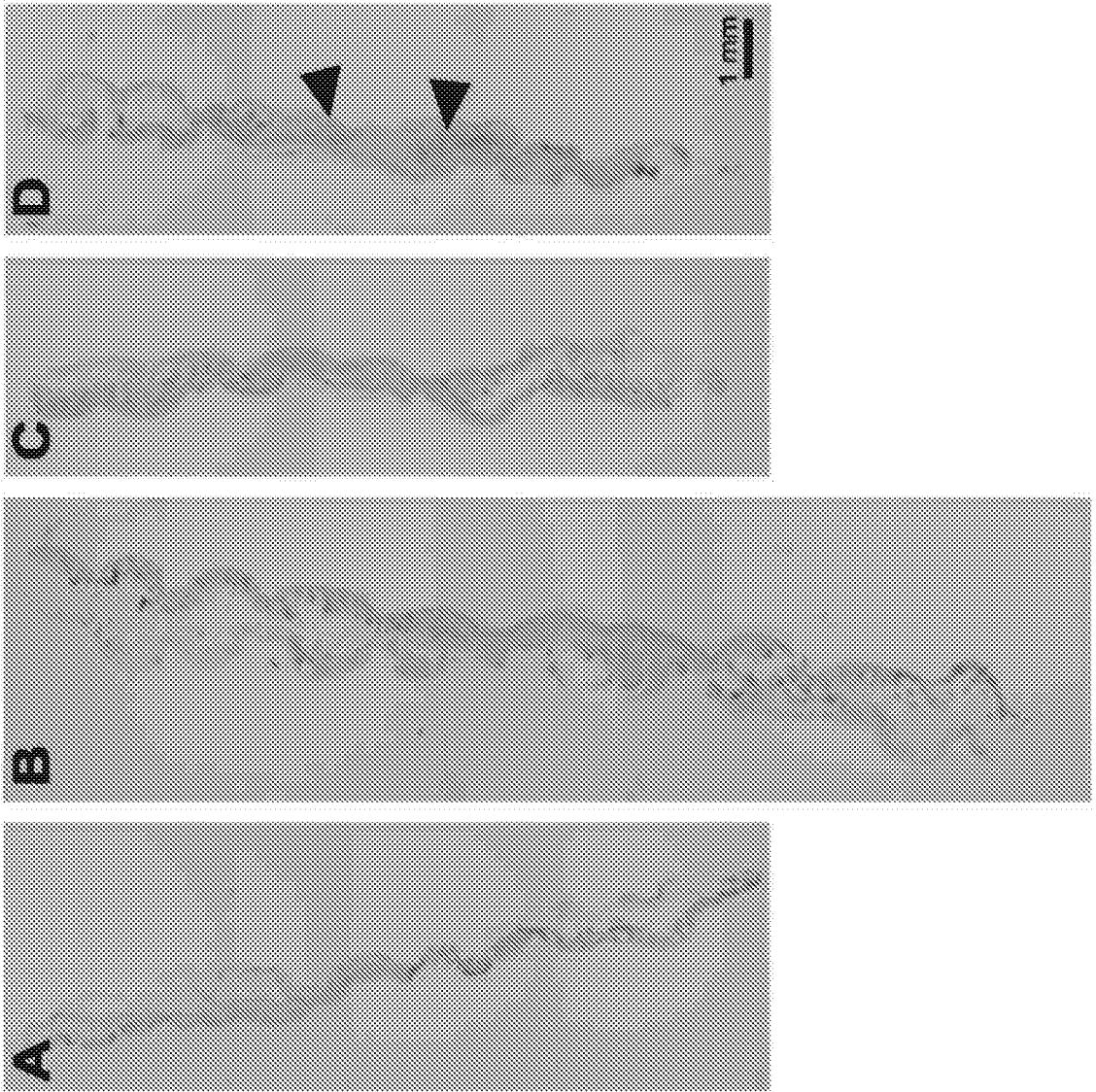

FIG. 27

FIG. 28

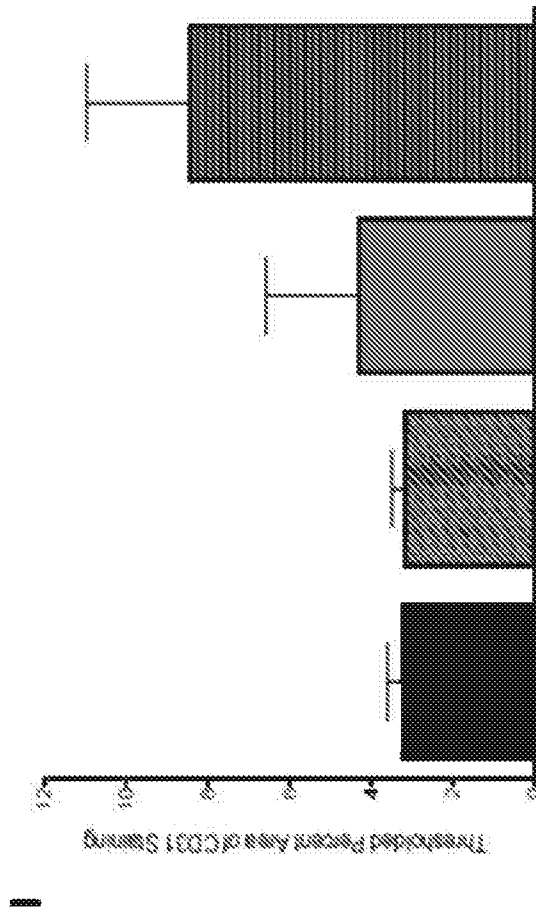
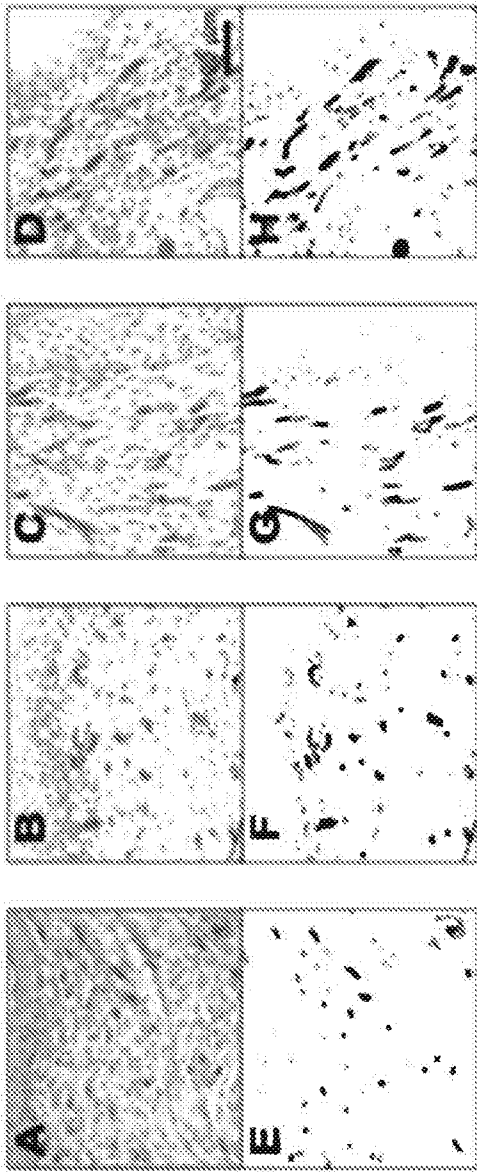

FIG. 29

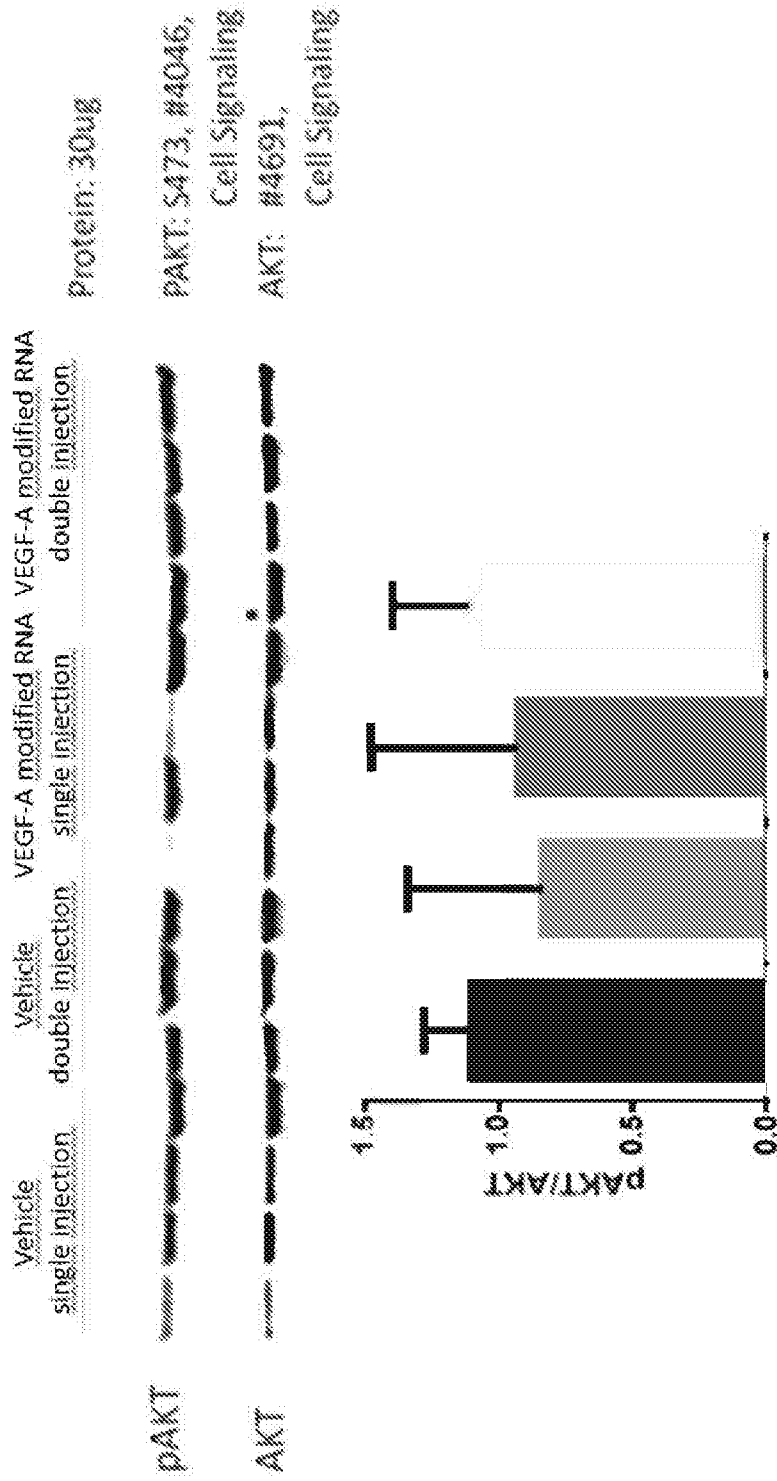
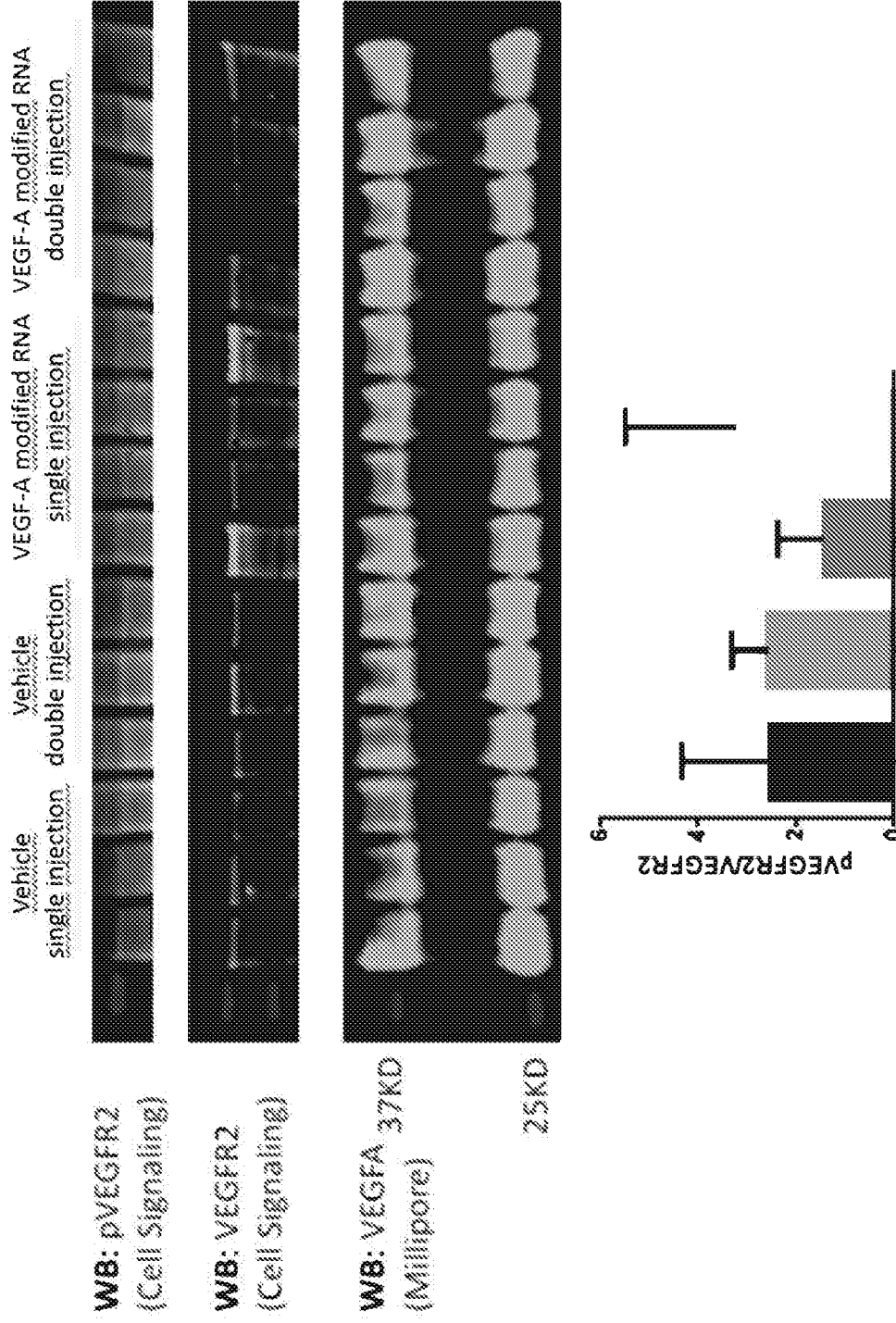
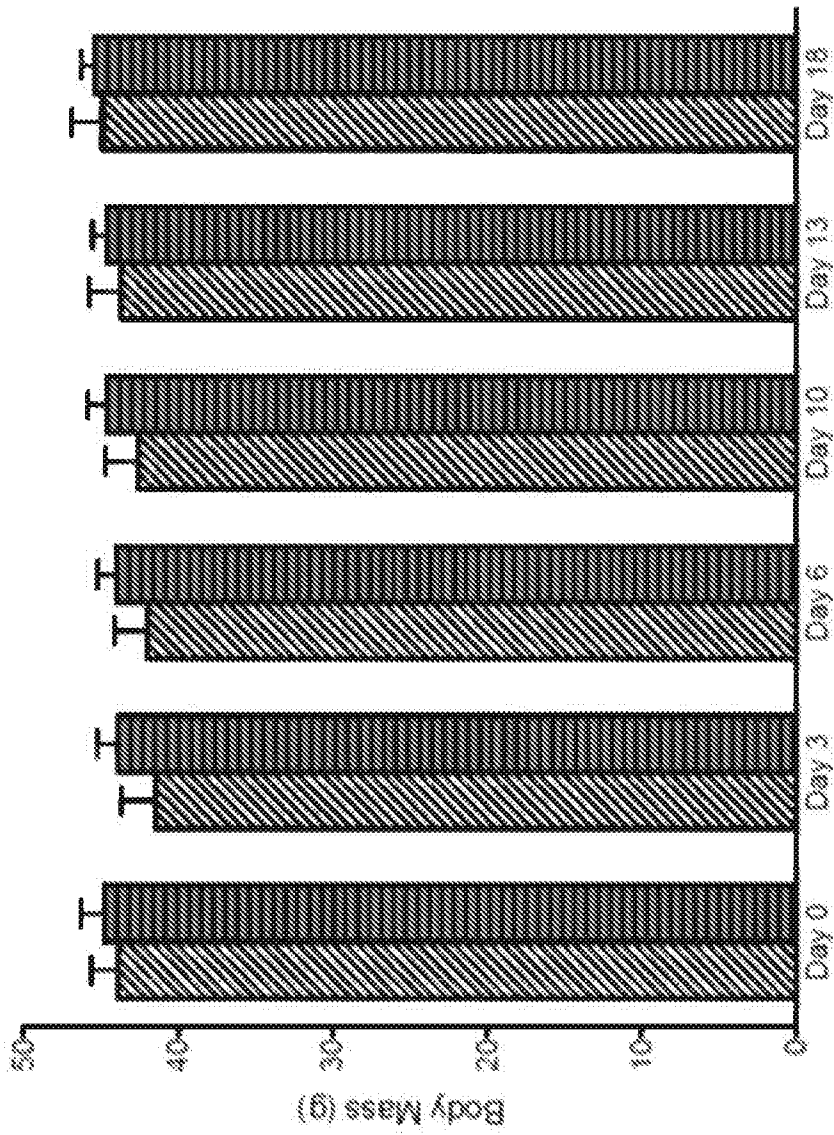

FIG. 30



2023208200 28 Jul 2023

FIG. 31



2023208200 28 Jul 2023

FIG. 32

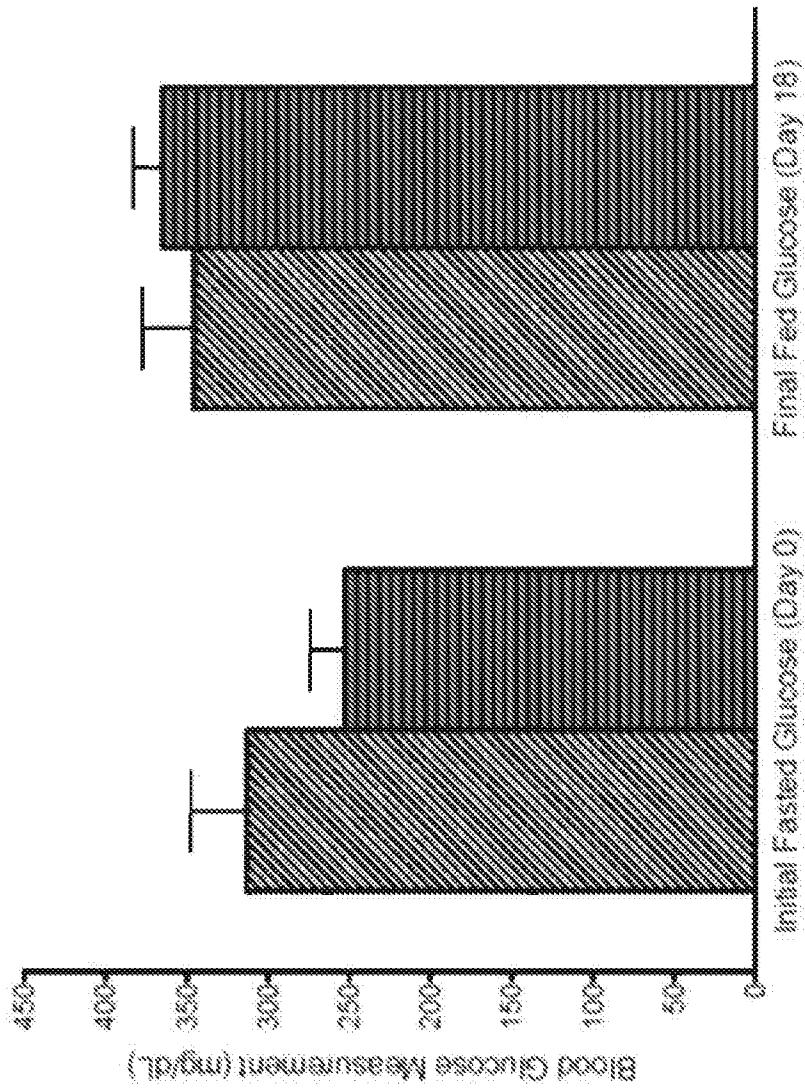

FIG. 33

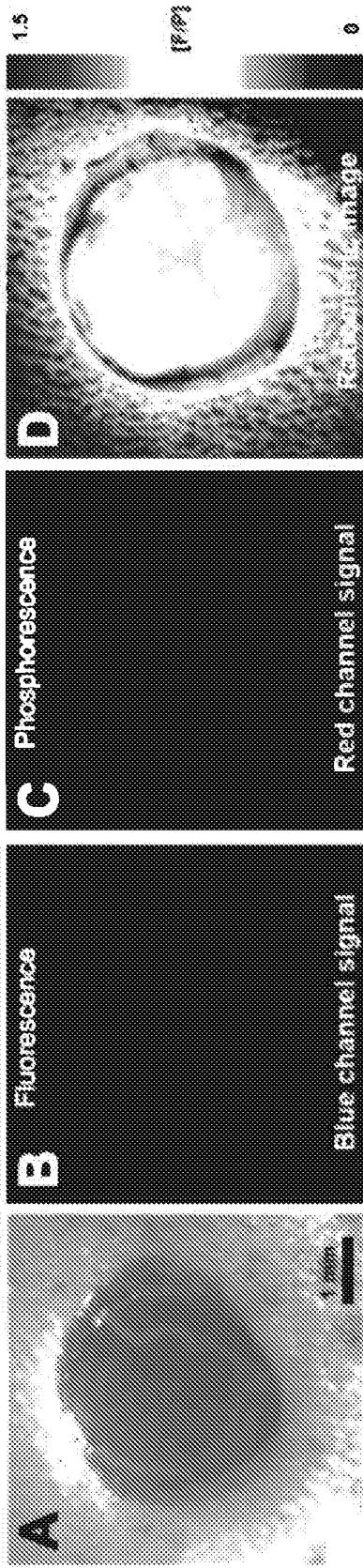
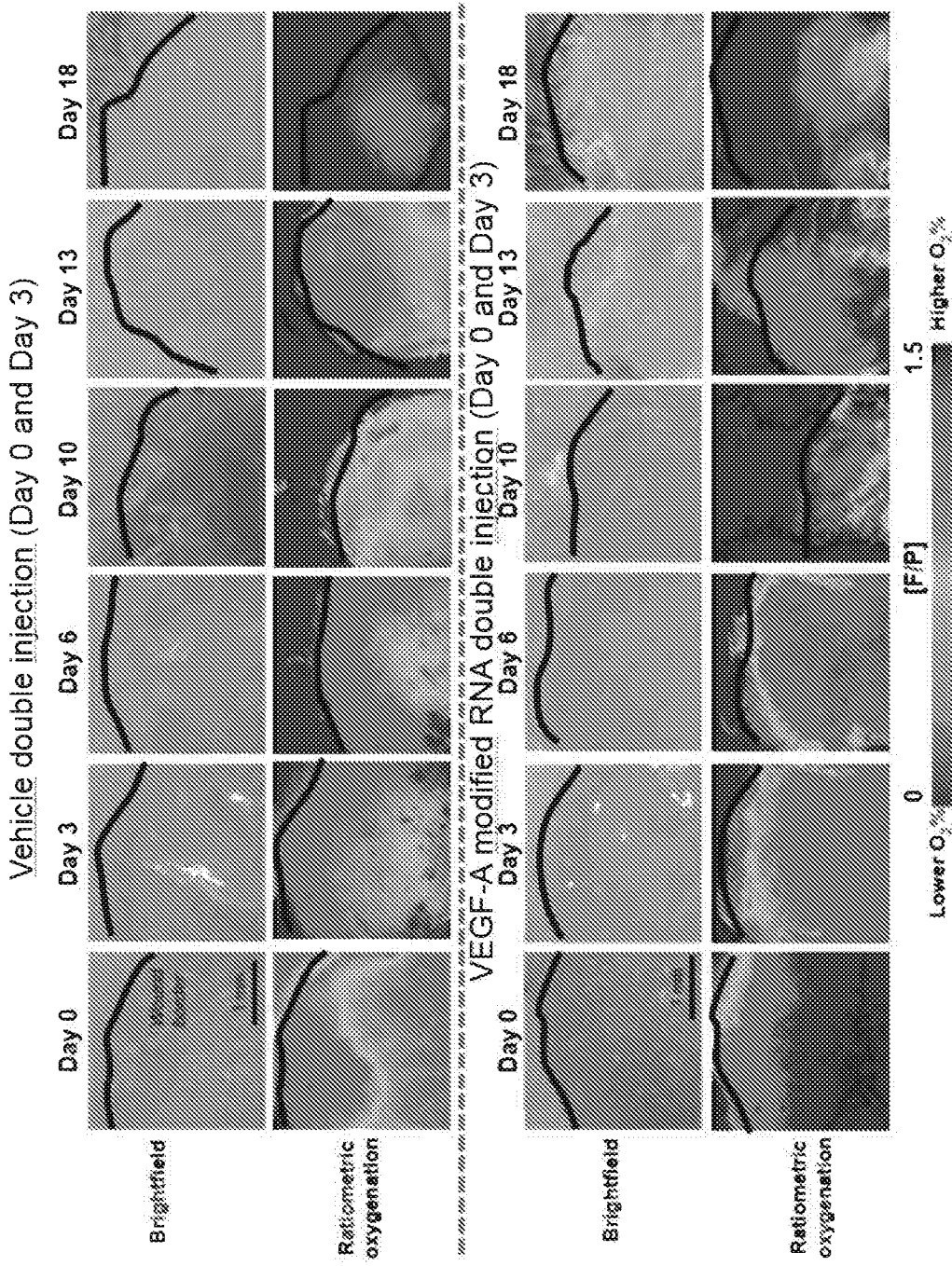
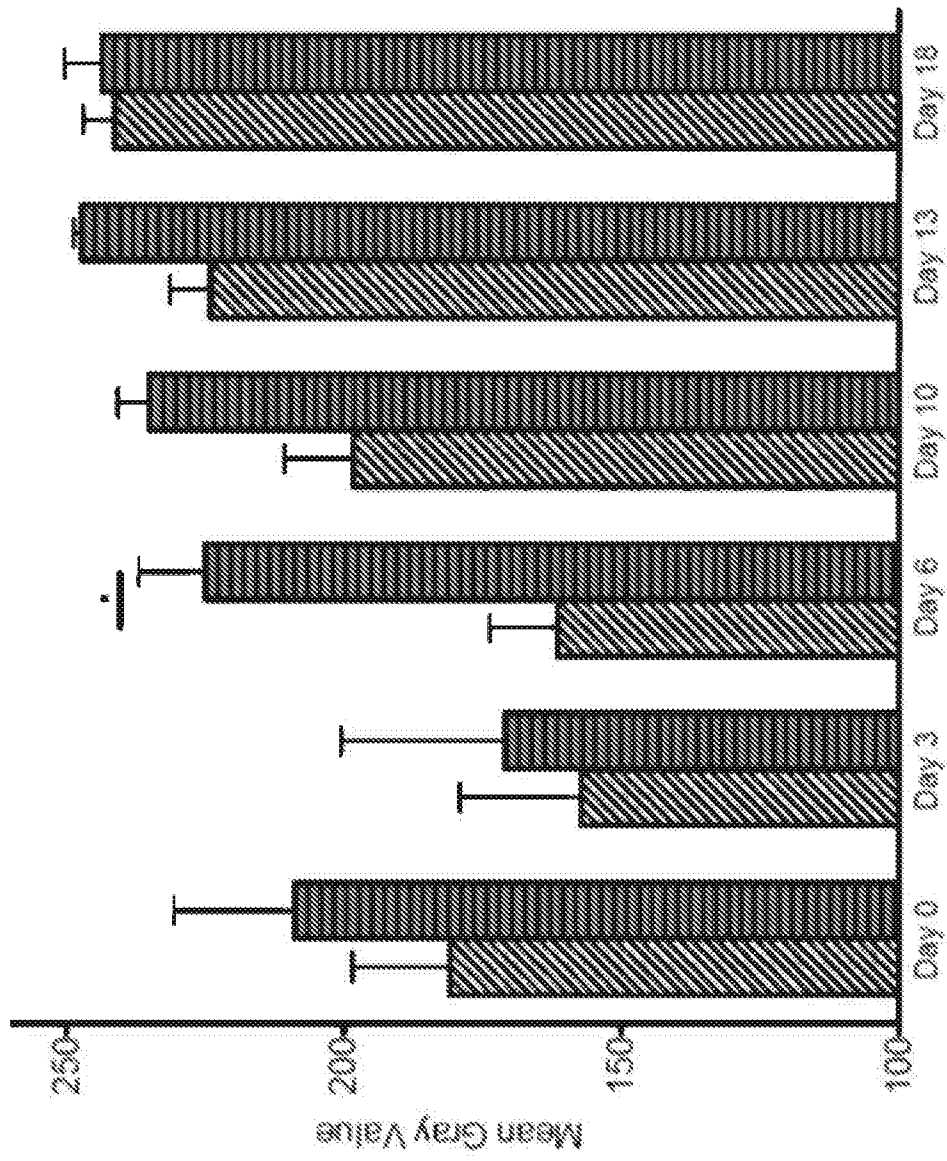

FIG. 34



2023208200 28 Jul 2023

FIG. 35



2023208200 28 Jul 2023

FIG. 36

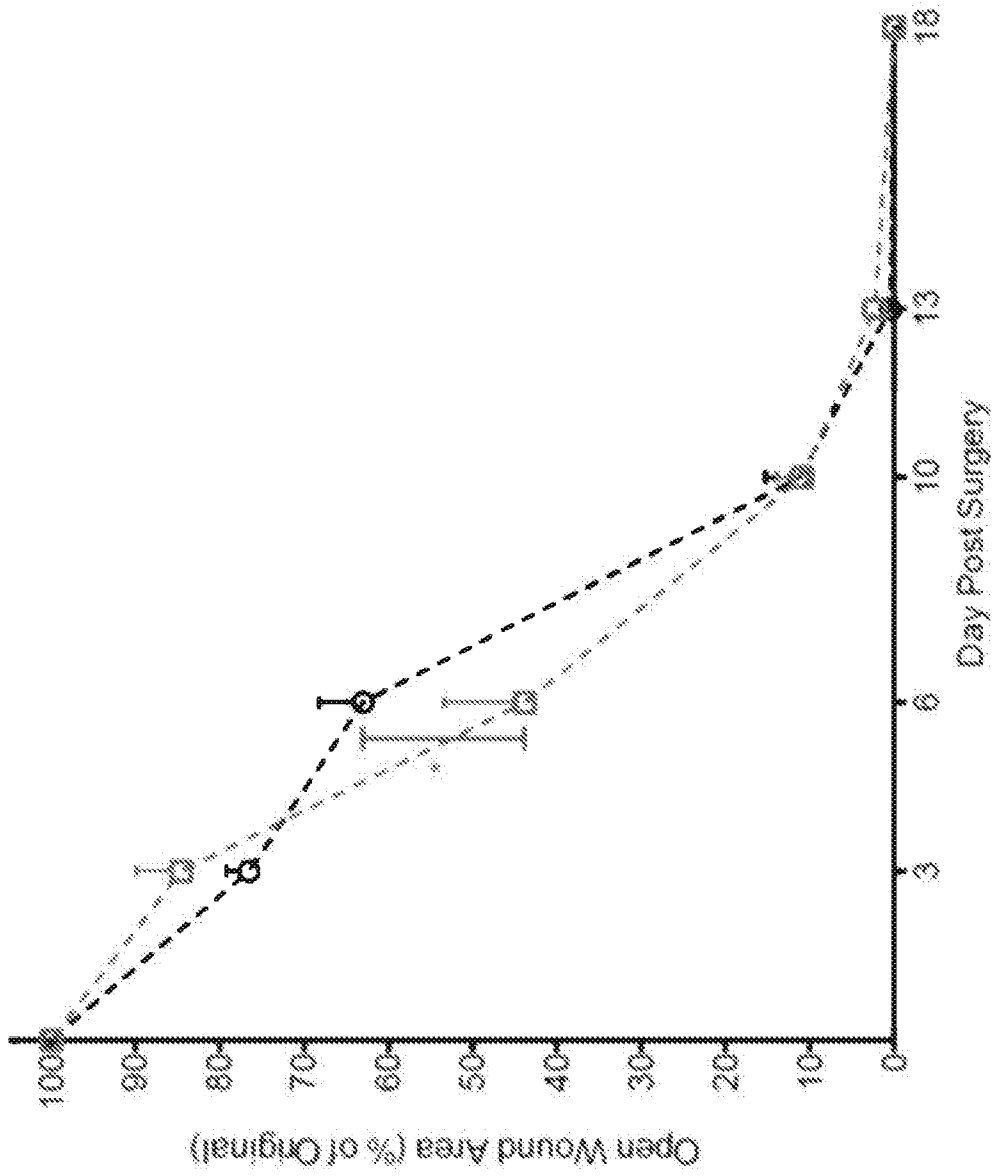

2023208200 28 Jul 2023

FIG. 37

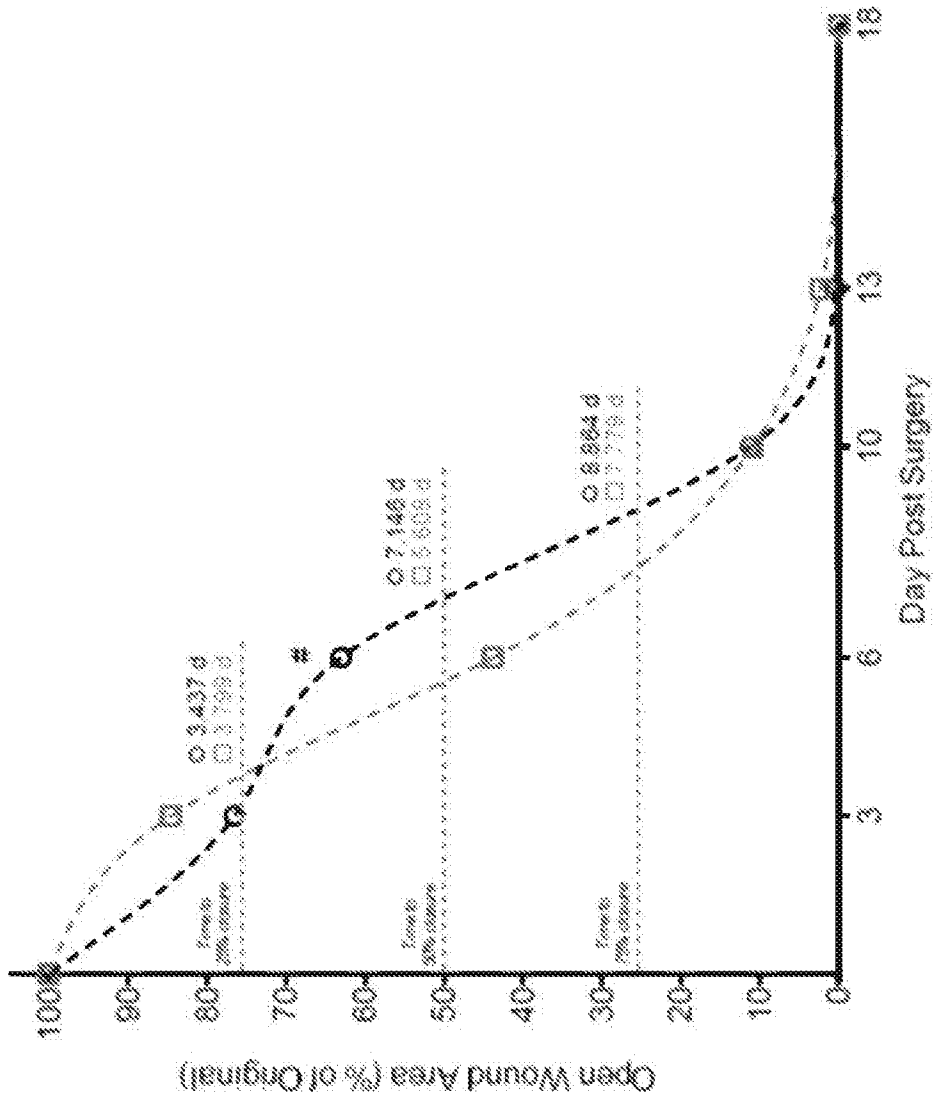
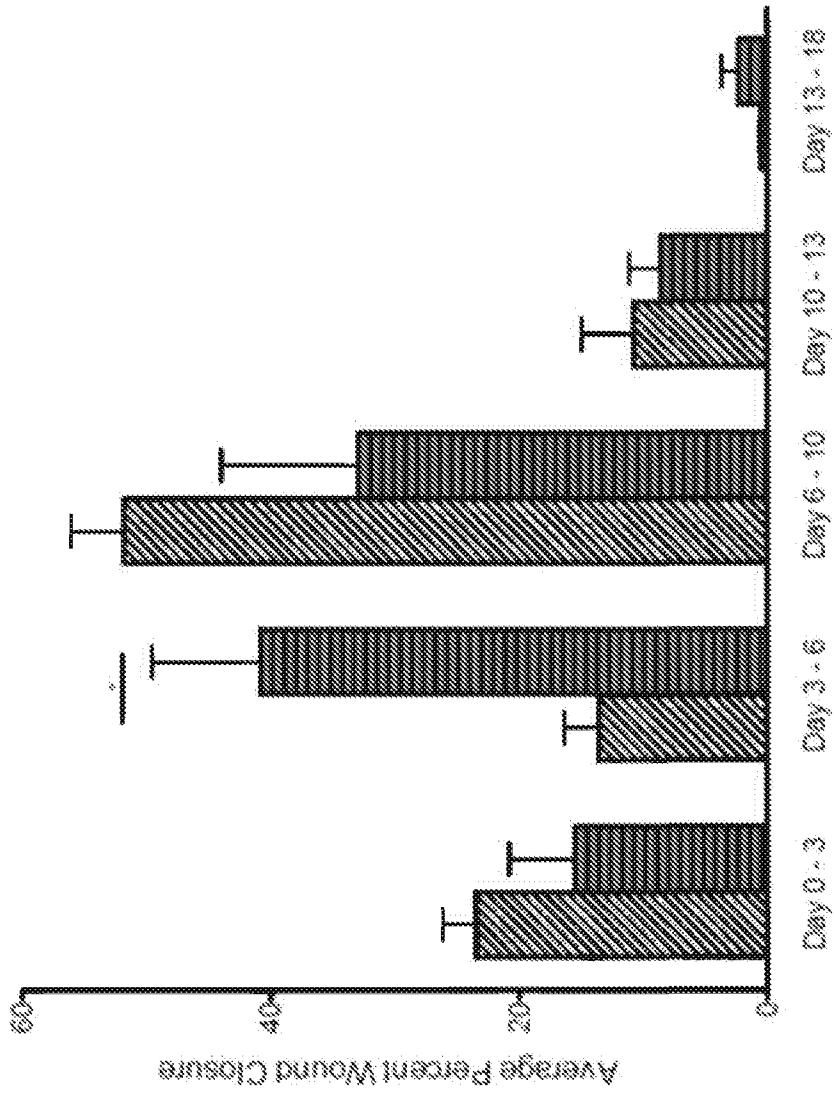

FIG. 38



2023208200 28 Jul 2023

FIG. 39

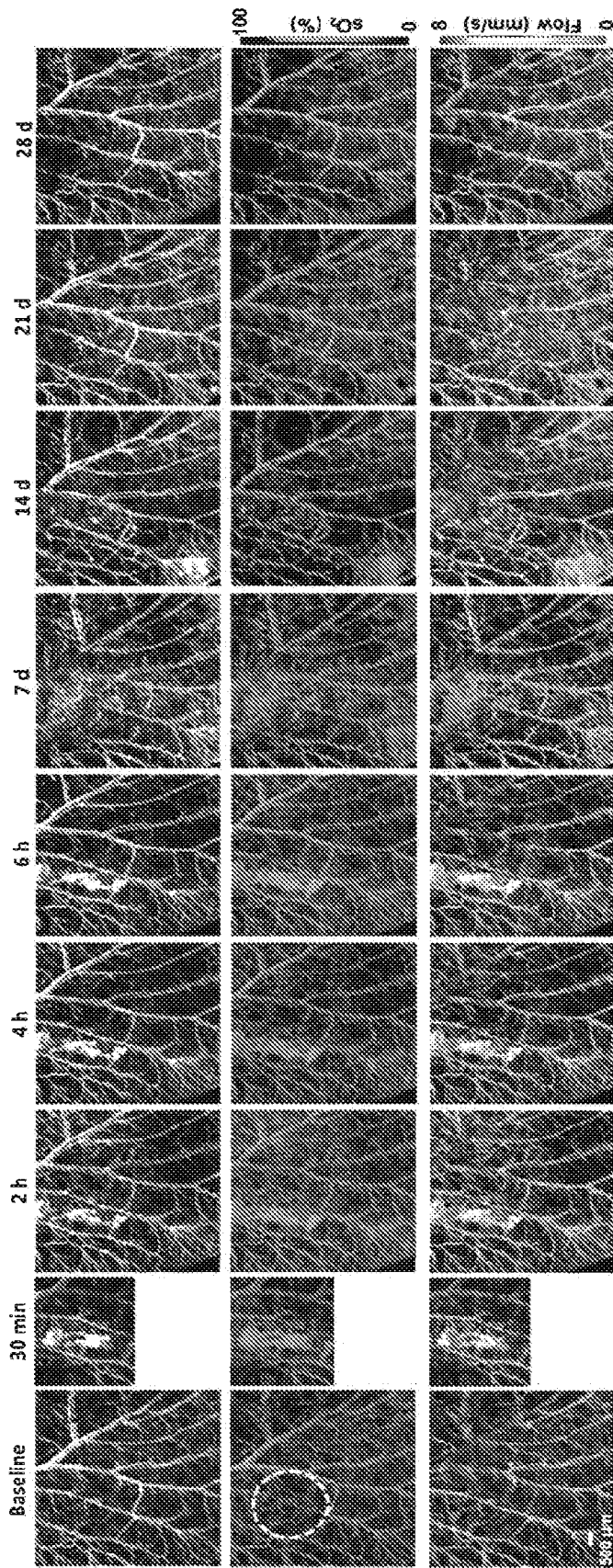
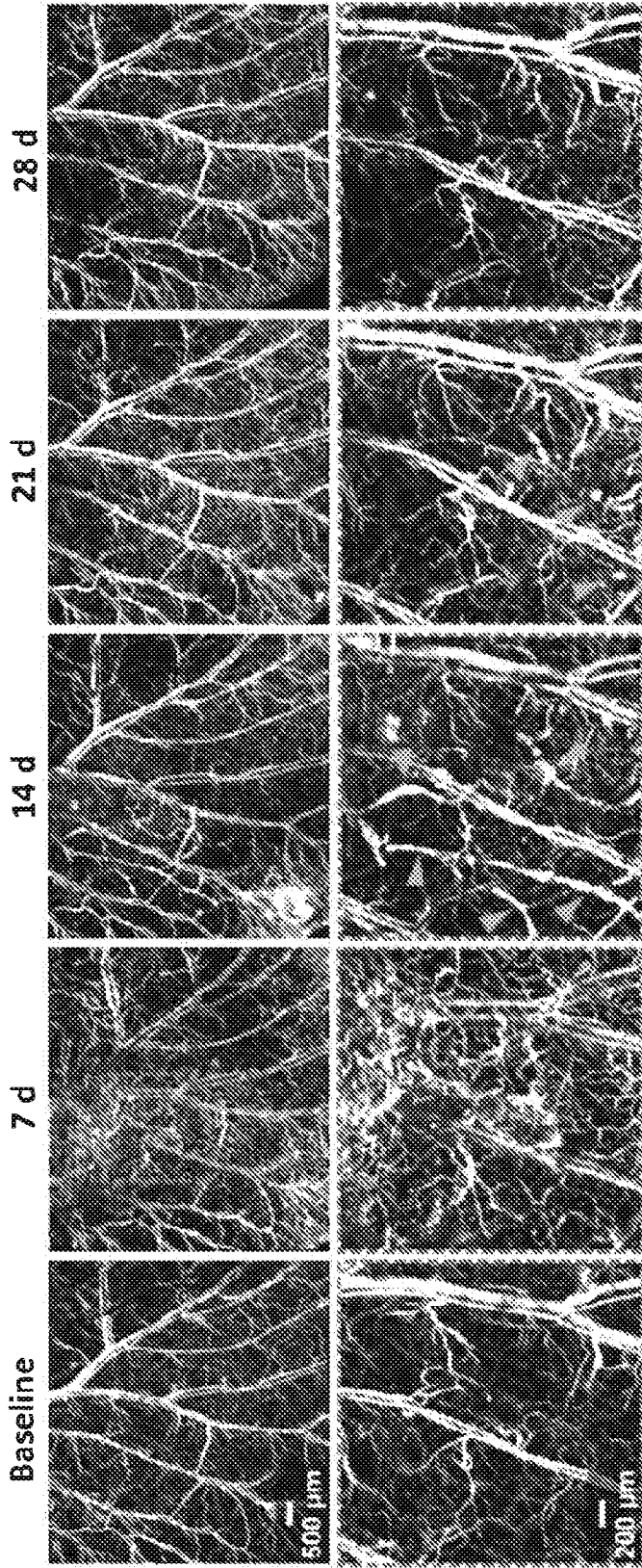
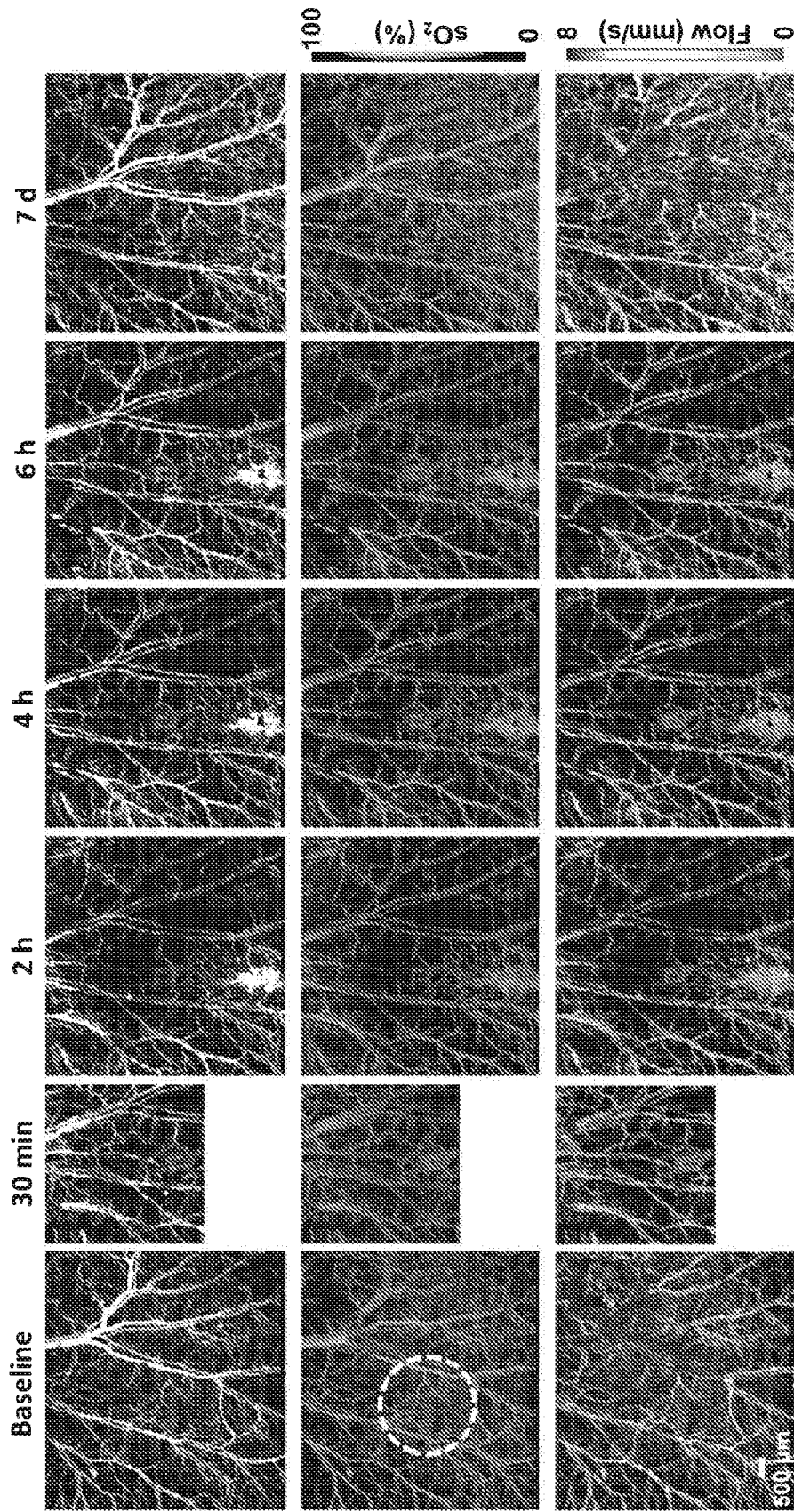

FIG. 40



2023208200 28 Jul 2023

FIG. 41



2023208200 28 Jul 2023

FIG. 42

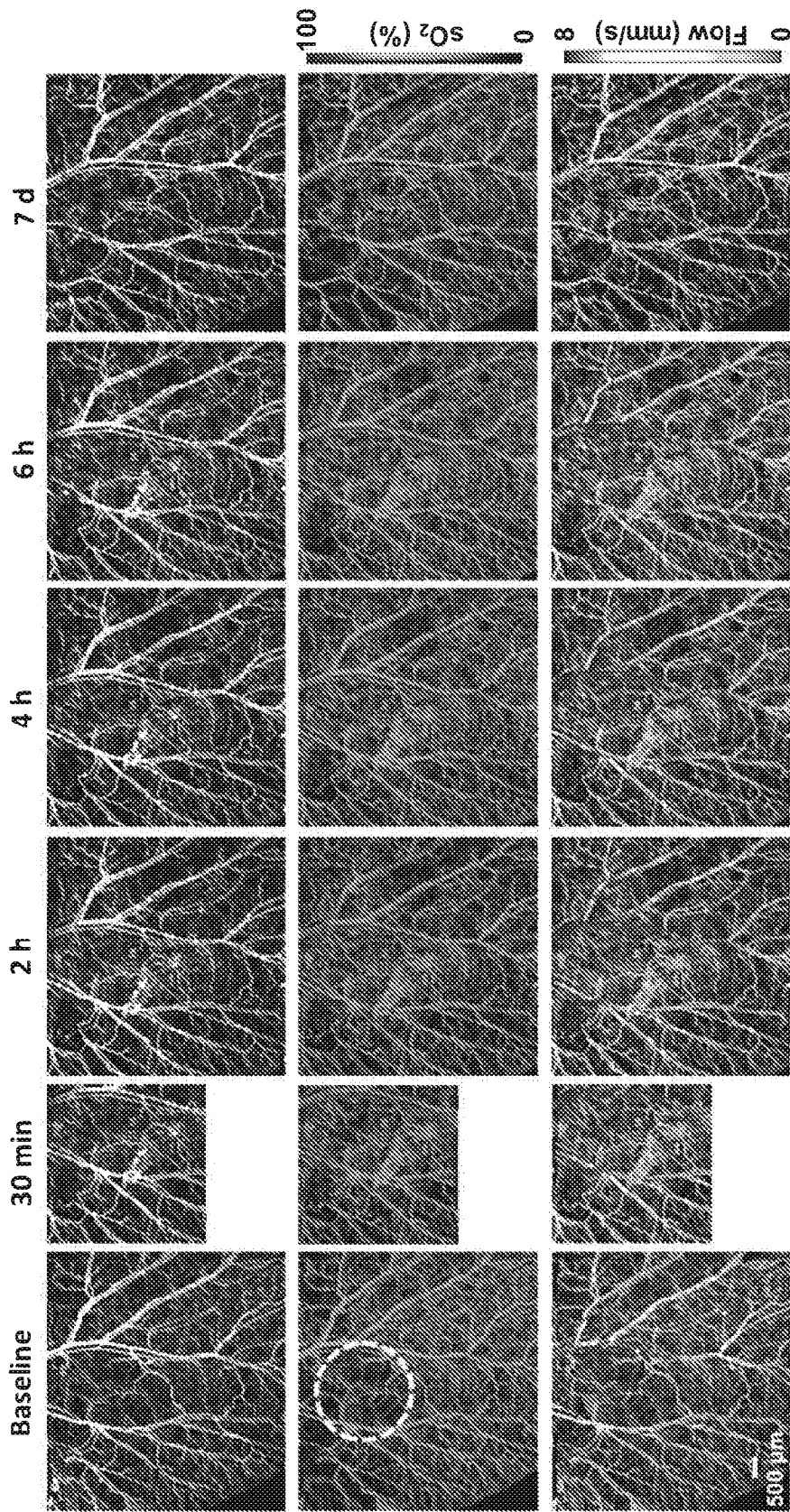

2023208200 28 Jul 2023

FIG. 43

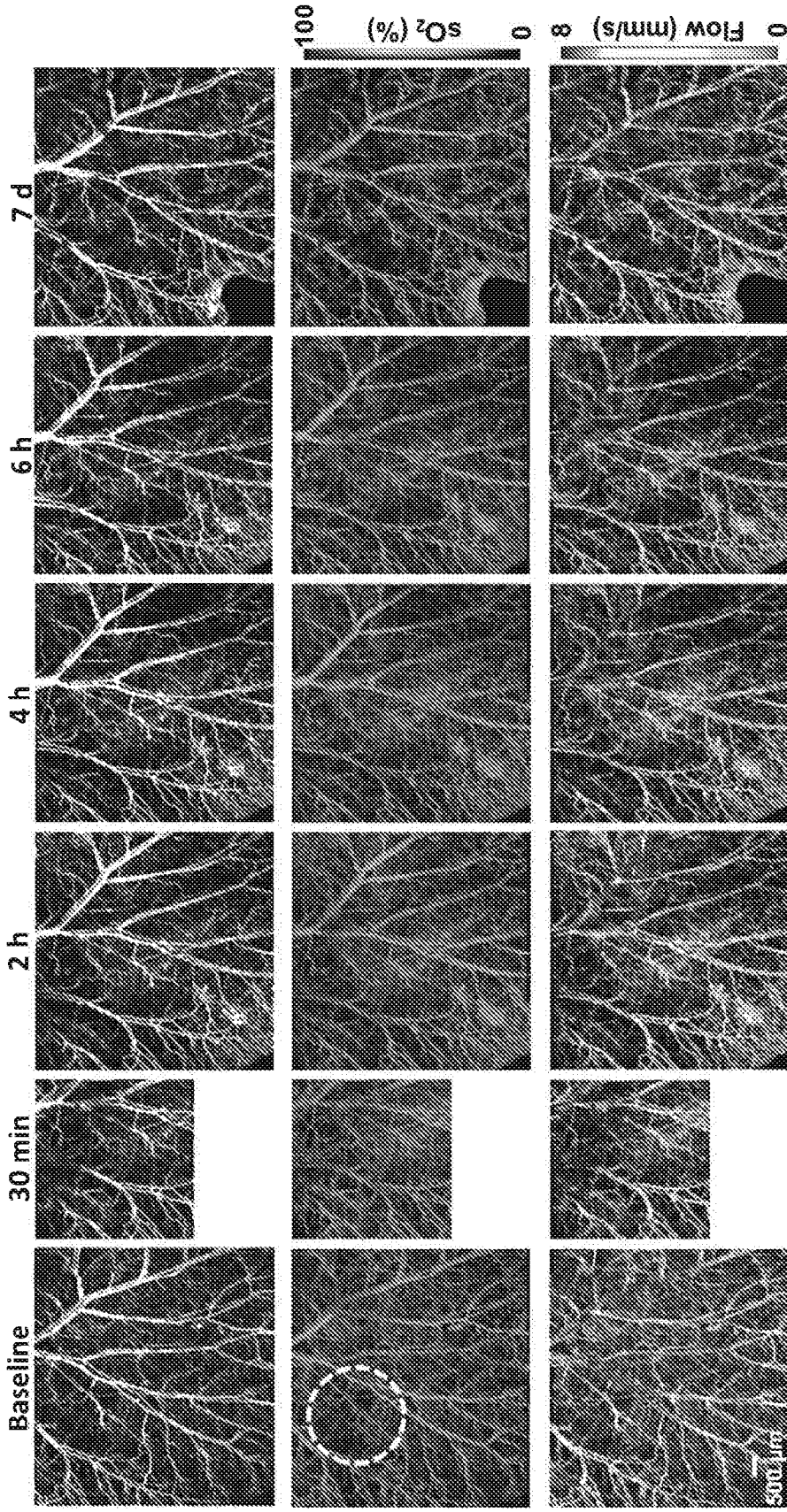

FIG. 44

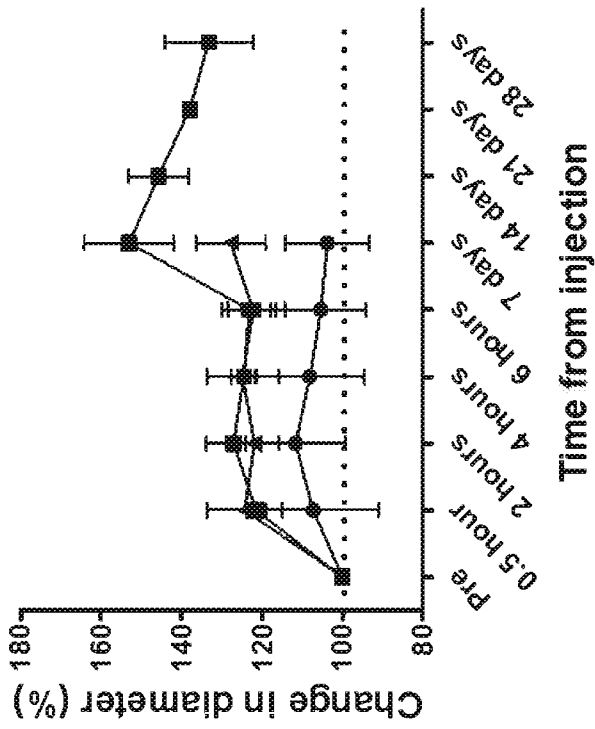
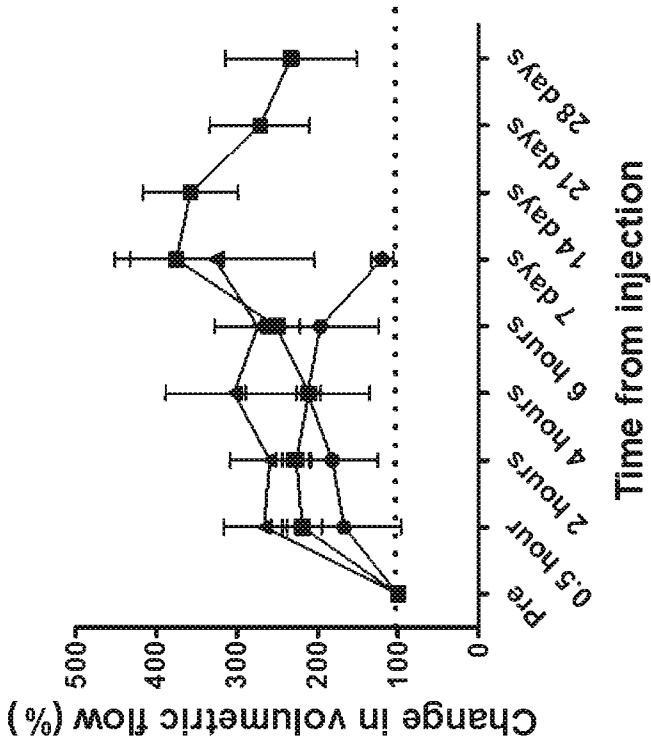

FIG. 45

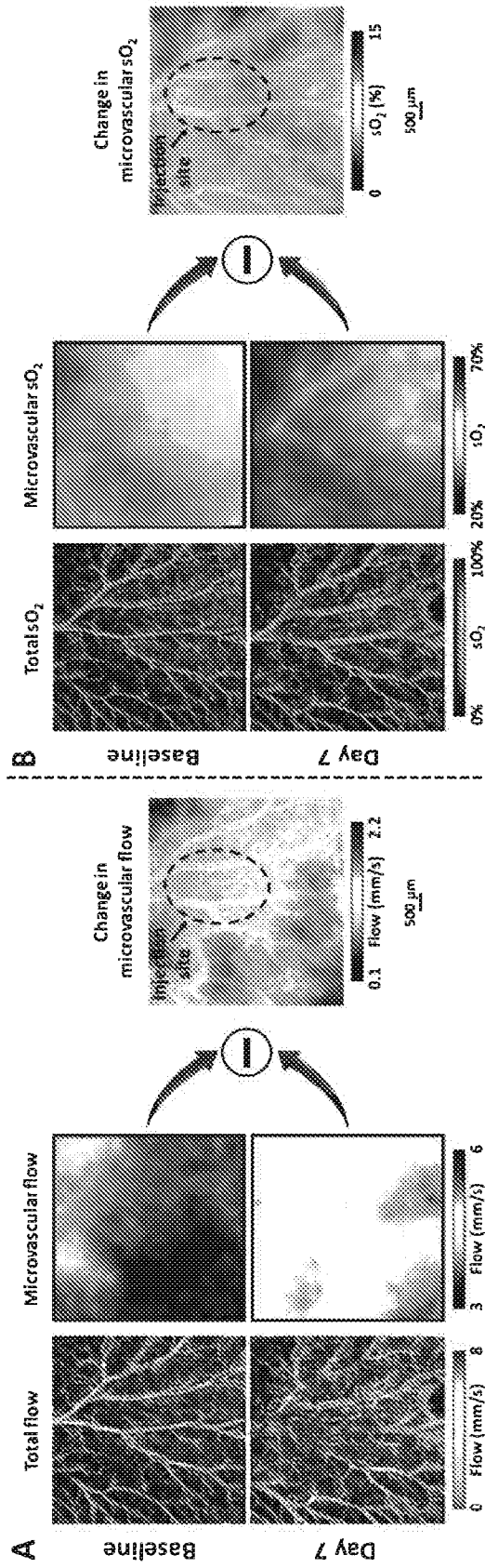

FIG. 46

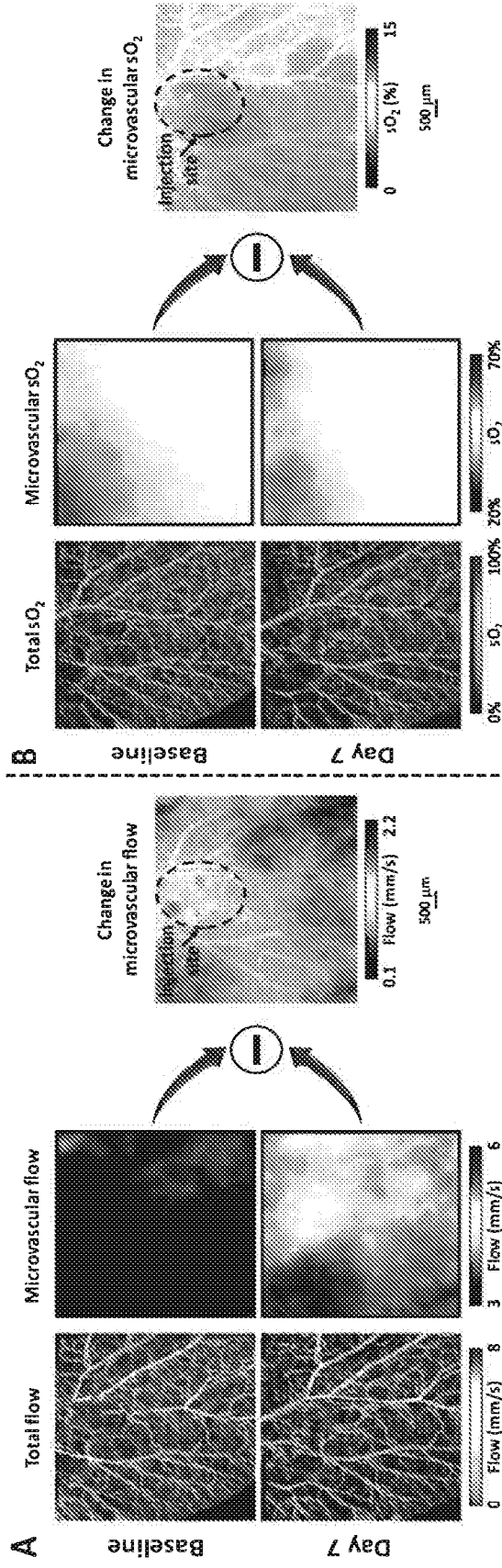

FIG. 47

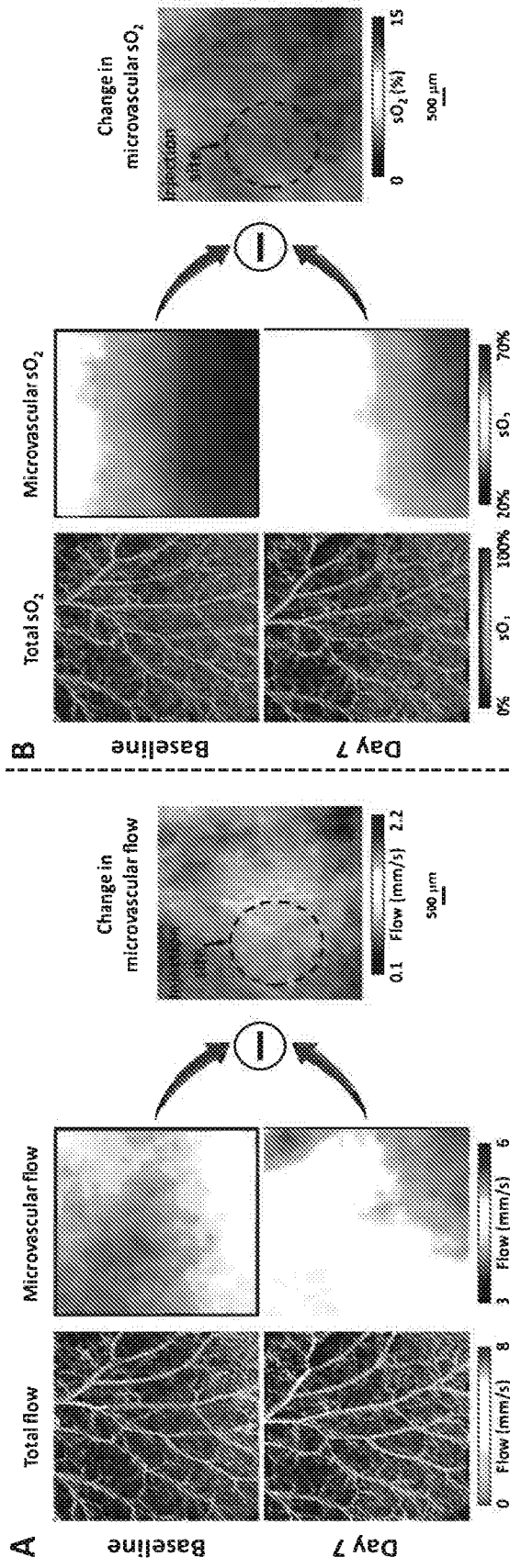

FIG. 48A

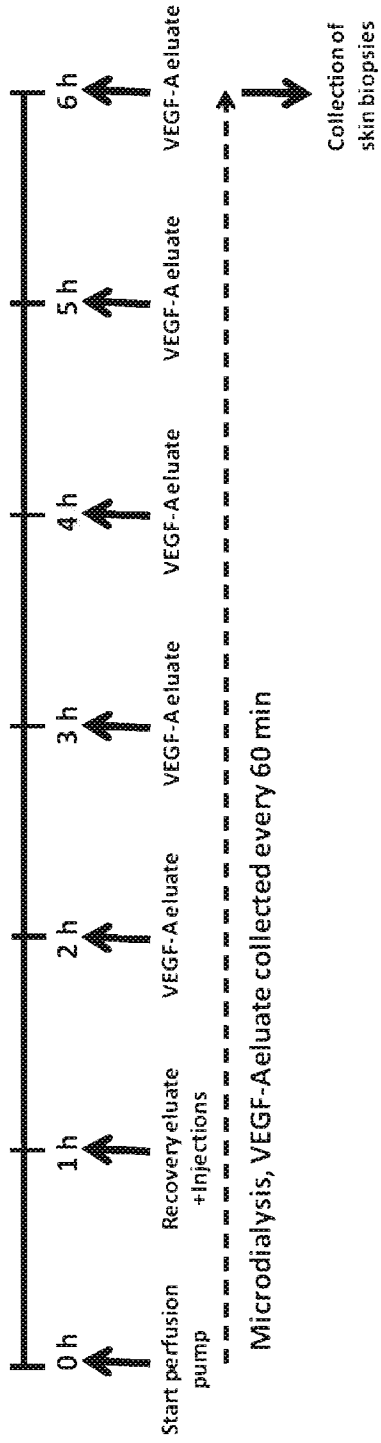

FIG. 48B

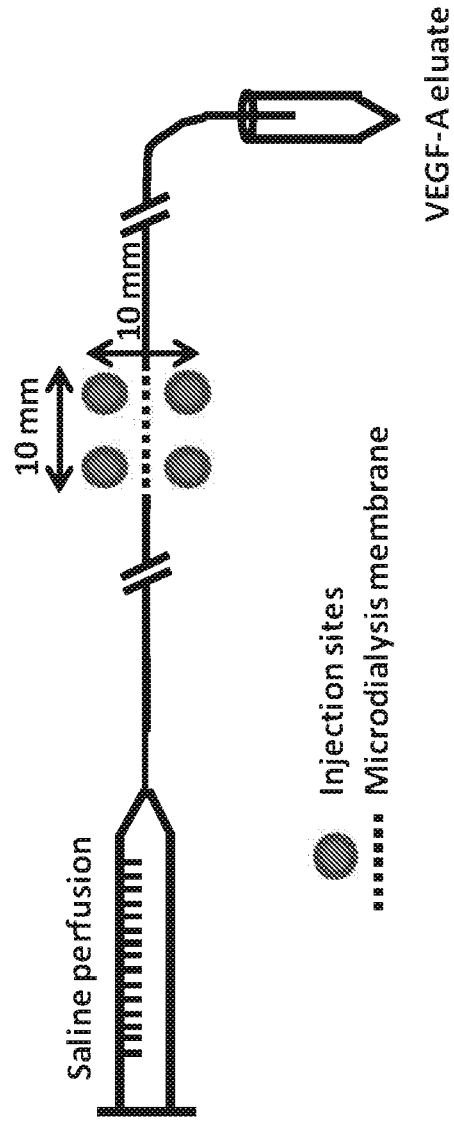
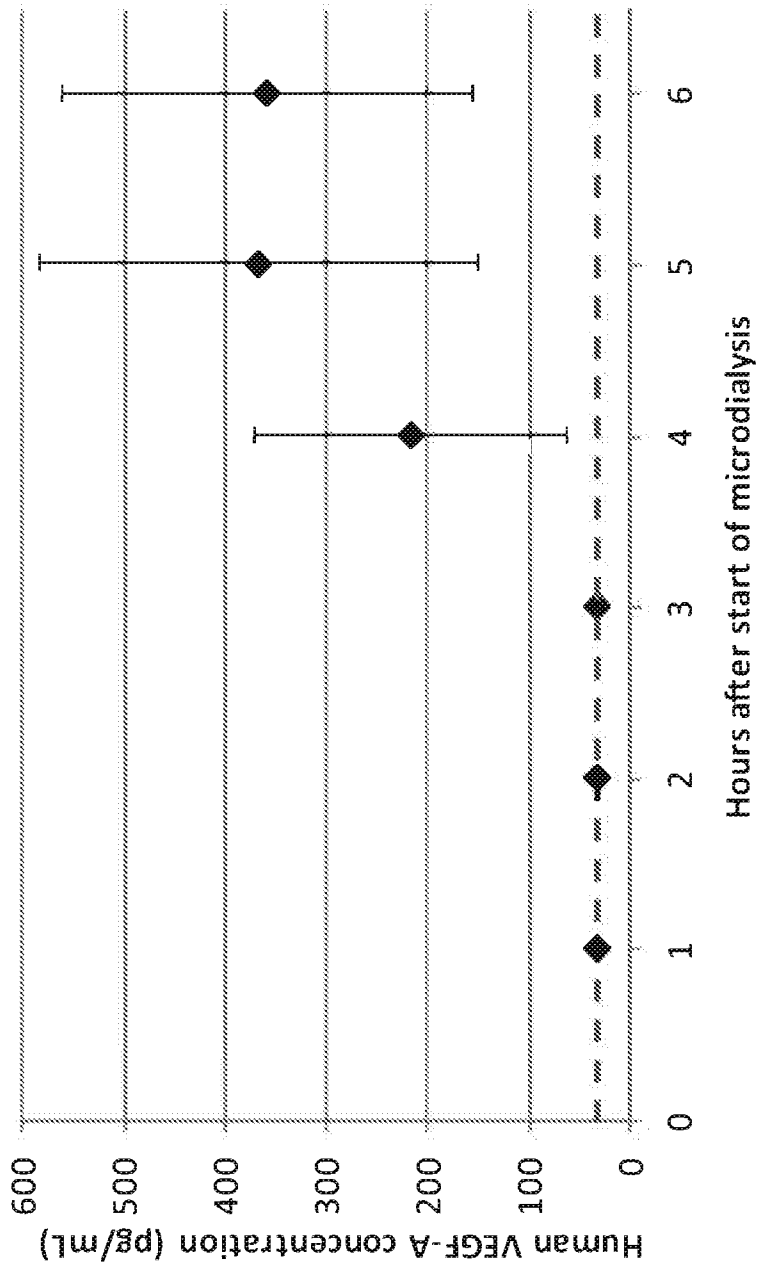

FIG. 49



2023208200 28 Jul 2023

FIG. 50A

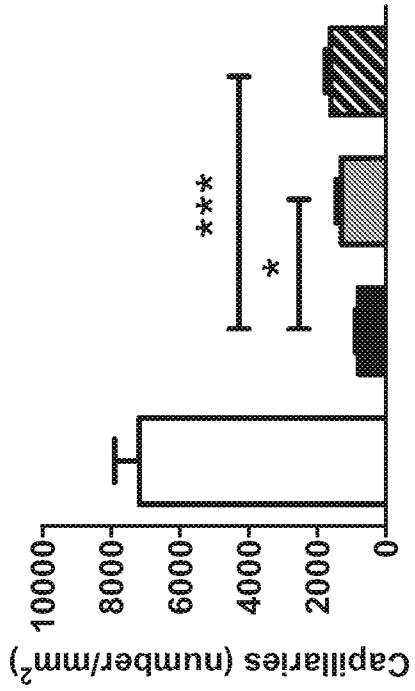

FIG. 50B

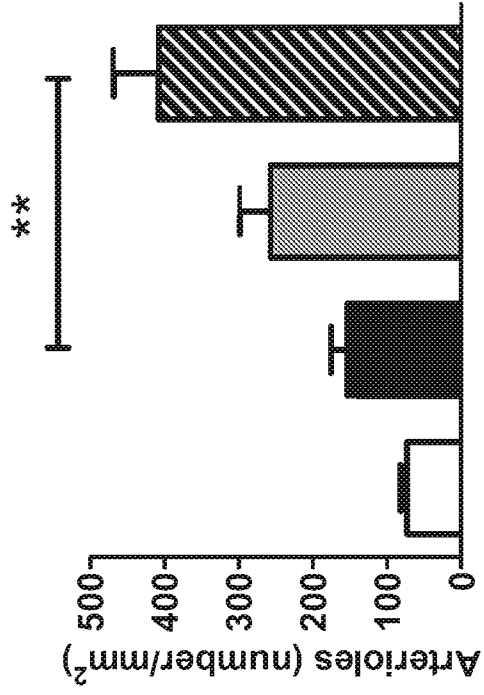
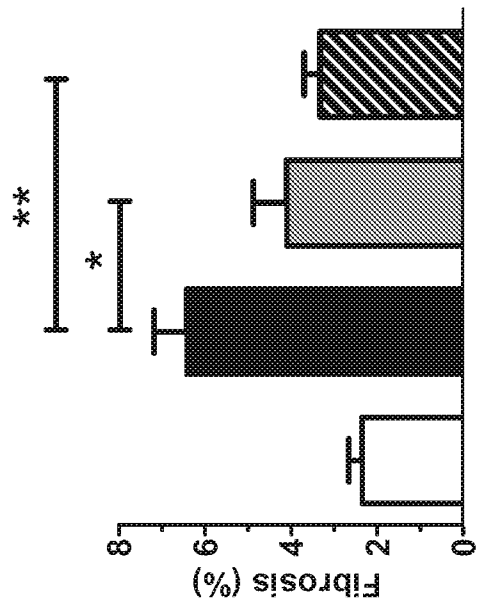

FIG. 50C



2023208200 28 Jul 2023

FIG. 51

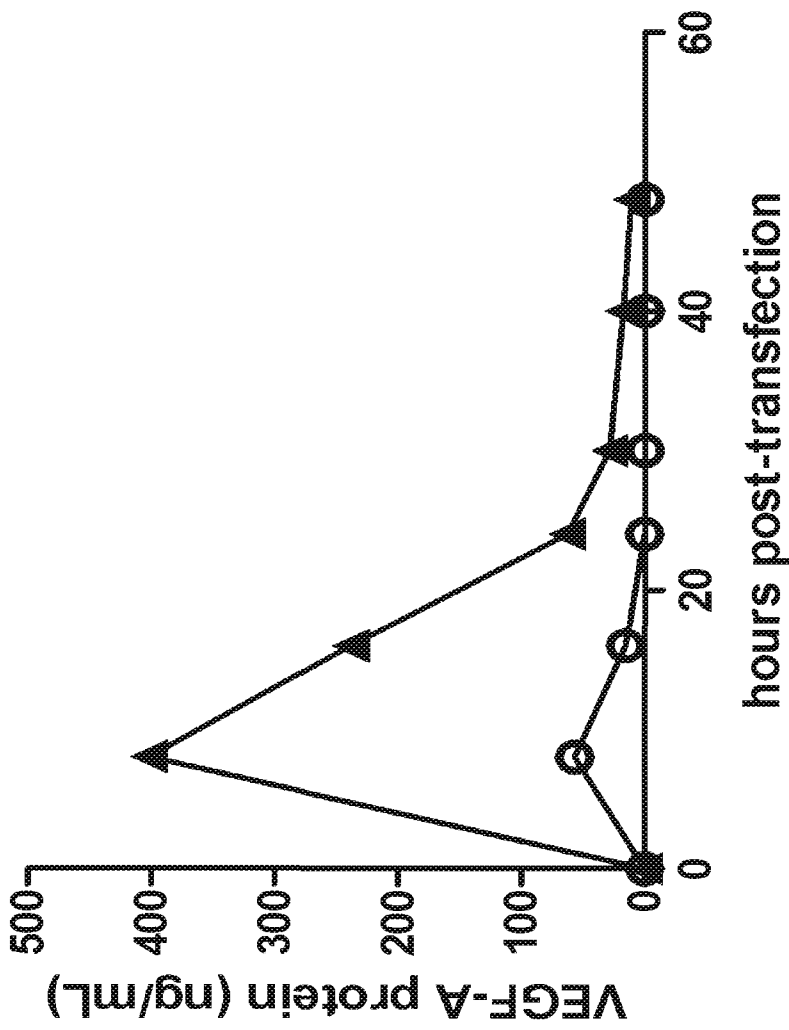

FIG. 52A

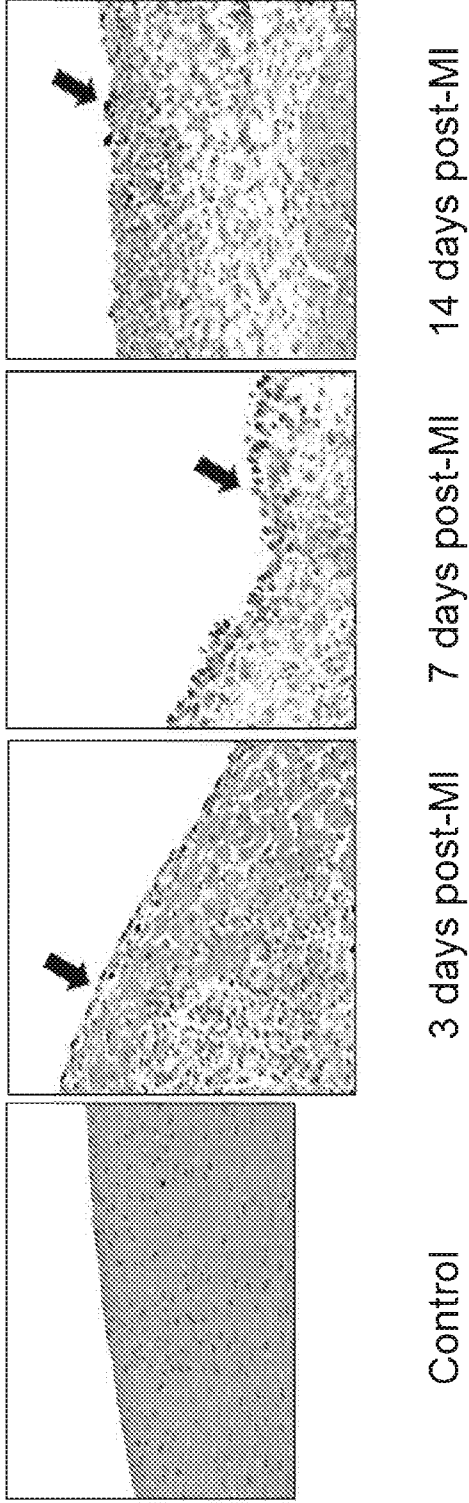
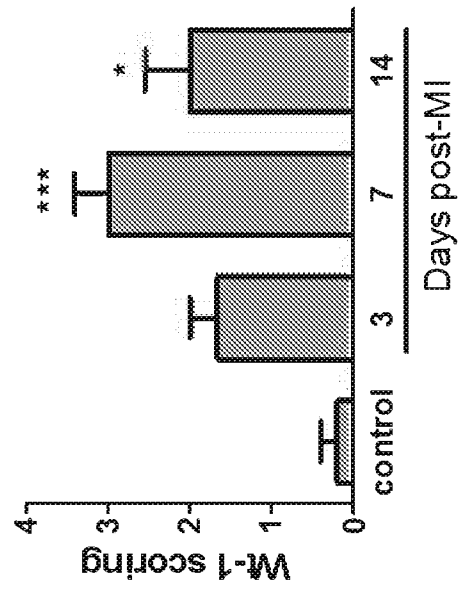

FIG. 52B



Sequence Listing

2023208200 28 Jul 2023

1	Sequence Listing Information	
1-1	File Name	1268739 - Sequence Listing.xml
1-2	DTD Version	V1_3
1-3	Software Name	WIPO Sequence
1-4	Software Version	2.3.0
1-5	Production Date	2023-07-28
1-6	Original free text language code	
1-7	Non English free text language code	
2	General Information	
2-1	Current application: IP Office	
2-2	Current application: Application number	
2-3	Current application: Filing date	
2-4	Current application: Applicant file reference	1268739
2-5	Earliest priority application: IP Office	US
2-6	Earliest priority application: Application number	62/346,979
2-7	Earliest priority application: Filing date	2016-06-07
2-8en	Applicant name	ModernaTX, Inc.
2-8	Applicant name: Name Latin	
2-9en	Inventor name	Leif Karlsson Parinder
2-9	Inventor name: Name Latin	
2-10en	Invention title	MODIFIED RNA ENCODING VEGF-A POLYPEPTIDES, FORMULATIONS, AND USES RELATING THERETO
2-11	Sequence Total Quantity	9

3-1	Sequences	
3-1-1	Sequence Number [ID]	1
3-1-2	Molecule Type	RNA
3-1-3	Length	845
3-1-4	Features	misc_feature 1..845
	Location/Qualifiers	note=Modified RNA encoding VEGF-A modified_base 1 mod_base=OTHER note=5' 7MeGppp, wherein Me = methyl and p = inorganic phosphate misc_feature 1..845 note=A = AMP, C = CMP, G = GMP, U = N1-methyl-pseudoUMP modified_base 2 mod_base=OTHER note=G2'OMe, wherein Me is methyl modified_base 845 mod_base=OTHER note=GOH 3' source 1..845 mol_type=other RNA organism=synthetic construct
3-1-5	NonEnglishQualifier Value Residues	ggggaaataa gagagaaaag aagagtaaga agaaatataa gagccaccat gaactttctg 60 ctgtcttggg tgcattggag ccttgccctg ctgctctacc tccaccatgc caagtgggtcc 120 caggctgcac ccatggcaga aggaggagg cagaatcatc acgaagtggg gaagtccatg 180 gatgtctatc agcgcagcta ctgccatcca atcgagacc tgggtggacat cttccaggag 240 taccctgatg agatcgagta catcttcaag ccatcctgtg tgccccctgat gcgatgctggg 300 ggctgctgca atgacgaggg cctggagtggt gtgcccactg aggagtccaa catcaccatg 360 cagattatgc ggatcaaacc tcaccaaggc cagcacatag gagagatgag cttcctacag 420 cacaacaaat gtgaatgcag accaaagaaa gatagagcaa gacaagaaaa tccctgtggg 480 ccttgctcag agcggagaaa gcatttgttt gtacaagatc cgcagacgtg taaatgttcc 540 tgcaaaaaca cagactcgcg ttgcaaggcg aggcagcttg agttaaacga acgtacttgc 600 agatgtgaca agccgaggcg gtgataatag gctggagcct cgggtggccat gcttcttgcc 660 ccttgggcct cccccagcc cctcctcccc ttctctgcacc cgtacccccg tggctcttga 720 ataaagtctg agtgggctggc aaaaaaaaaa aaaaaaaaaa aaaaaaaaaa aaaaaaaaaa 780 aaaaaaaaaa aaaaaaaaaa aaaaaaaaaa aaaaaaaaaa aaaaaaaaaa aaaaaaaaaa 840 tctag 845
3-2	Sequences	
3-2-1	Sequence Number [ID]	2
3-2-2	Molecule Type	AA
3-2-3	Length	191
3-2-4	Features	source 1..191
	Location/Qualifiers	mol_type=protein organism=Homo sapiens
3-2-5	NonEnglishQualifier Value Residues	MNFLLSWVHW SLALLLYLHH AKWSQAAPMA EGGGQNHHEV VKFMDVYQRS YCHPIETLVD 60 IFQEYPDEIE YIFKPSVPL MRCGGCCNDE GLECVPTES NITMQIMRIK PHQGQHIGEM 120 SFLQHNKCEC RPKKDRARQE NPCGPCSERR KHLFVQDPQT CKCSCKNTDS RCKARQLELN 180 ERTCRCDKPR R 191
3-3	Sequences	
3-3-1	Sequence Number [ID]	3
3-3-2	Molecule Type	RNA
3-3-3	Length	47
3-3-4	Features	misc_feature 1..47
	Location/Qualifiers	note=Firefly luciferase 5' UTR misc_feature 1..47 note=A = AMP, C = CMP, G = GMP, U = N1-methyl-pseudoUMP source 1..47 mol_type=other RNA organism=synthetic construct
3-3-5	NonEnglishQualifier Value Residues	gggaaataag agagaaaaga agagtaagaa gaaatataag agccacc 47
3-4	Sequences	
3-4-1	Sequence Number [ID]	4
3-4-2	Molecule Type	RNA
3-4-3	Length	1650
3-4-4	Features	misc_feature 1..1650
	Location/Qualifiers	note=Firefly luciferase ORF of mRNA construct (excluding the stop cod on) misc_feature 1..1650 note=A = AMP, C = CMP, G = GMP, U = N1-methyl-pseudoUMP source 1..1650

<p>3-4-5</p>	<p>NonEnglishQualifier Value Residues</p>	<p>mol_type=other RNA organism=synthetic construct</p> <pre> atggaagatg cgaagaacat caagaagga cctgccccgt tttacccttt ggaggacggt 60 acagcaggag aacagctcca caaggcgatg aaacgctacg ccctggtccc cggaacgatt 120 gcgtttaccg atgcacatat tgaggtagac atcacatacg cagaatactt cgaaatgtcg 180 gtgaggctgg cgaagcgatg gaagagatat ggtcttaaca ctaatcaccg catcgtgggtg 240 tgttcggaga actcattgca gtttttcatg ccggctcttg gagcactttt catcggggtc 300 gcagtcgocg cagcgaacga catctacaat gagcgggaac tcttgaatag catgggaatc 360 tcccagccga cggctcgtgtt tgtctccaaa aaggggctgc agaaaatcct caacgtgcag 420 aagaagctcc ccattattca aaagatcatc attatggata gcaagacaga ttaccaaggg 480 ttccagtcga tgtatacctt tgtgacatcg cttttgcgc caggggttaa cgagtatgac 540 ttcgtccccg agtcatttga cagagataaa accatcgcgc tgattatgaa ttcctcgggt 600 agcaccggtt tgccaaaggg ggtggcgctg ccccaccgca ctgcttgtgt gcggttctcg 660 cacgctaggg atcctatctt tggtaatcag atcattcccc acacagcaat cctgtccggtg 720 gtaccttttc atcacggttt tggcatgttc acgactctcg gctatttgat ttgcgggttc 780 agggtcgtac ttatgtatcg gttcagggaa gaactgtttt tgagatcctt gcaagattac 840 aagatccagt cggccctcct tgtgccaaag ctttttctcat tcttttgcgaa atcgacactt 900 attgataagt atgaccttc caatctgcat gagattgctt caggggggagc gccgcttagc 960 aagggaagtc gggaggcagt ggccaagcgc ttccacctc cgggaattcg gcagggatac 1020 gggctcacgg agacaacatc cgcgatcctt atcacgccc aggggtgacga taagccggga 1080 gccgtcggaa aagtgggtccc cttctttgaa gccaaagtcg tagacctcga cacgggaaaa 1140 accctcggag tgaaccagag gggcgagctc tgcgtgagag ggcgatgat catgtcaggt 1200 tacgtgaata accctgaagc gacgaatgag ctgatcgaca aggatgggtg gttgcattcg 1260 ggagacattg cctattggga tgaggatgag cacttcttta tcgtagatcg acttaagagc 1320 ttgatcaaat acaaaggcta tcaggtagcg cctgccgagc tcgagtcaat cctgctccag 1380 caccocaaca ttttcgacgc cggagtggcc gggttgccc atgacgacgc gggtagctg 1440 ccagcggccg tggtagtctt cgaacatggg aaaacaatga ccgaaaagga gatcgtggac 1500 tacgtagcat cacaagtgac gactgcgaag aaactgaggg gaggggtagt ctttgtggac 1560 gaggtcccga aaggcttgac tgggaagctt gacgctcgca aaatccggga aatcctgatt 1620 aaggcaaaaga aaggcgggaa aatcgctgtc 1650 </pre>
<p>3-5 3-5-1 3-5-2 3-5-3 3-5-4 3-5-5</p>	<p>Sequences Sequence Number [ID] Molecule Type Length Features Location/Qualifiers NonEnglishQualifier Value Residues</p>	<p>5 RNA 119 misc_feature 1..119 note=Firefly luciferase 3' UTR misc_feature 1..119 note=A = AMP, C = CMP, G = GMP, U = N1-methyl-pseudoUMP source 1..119 mol_type=other RNA organism=synthetic construct</p> <pre> tgataatagg ctggagcctc ggtggccatg cttcttgccc cttgggcctc cccccagccc 60 ctcctccct tctgacacc gtacccccgt ggtctttgaa taaagtctga gtgggcggc 119 </pre>
<p>3-6 3-6-1 3-6-2 3-6-3 3-6-4 3-6-5</p>	<p>Sequences Sequence Number [ID] Molecule Type Length Features Location/Qualifiers NonEnglishQualifier Value Residues</p>	<p>6 AA 550 REGION 1..550 note=Firefly luciferase source 1..550 mol_type=protein organism=synthetic construct</p> <pre> MEDAKNIKKG PAFYPLEDG TAGEQLHKAM KRYALVPGTI AFTDAHIEVD ITYAEYFEMS 60 VRLAEAMKRY GLTNHRIVV CSENSLQFFM PVLGALFIGV AVAPANDIYN ERELLNSMGI 120 SQPTVVFVSK KGLQKILNVQ KKLPIIQKII IMDSKTDYQG FQSMYTFVTS HLPFGFNEYD 180 FVPESFDRDK TIALIMNSSG STGLPKGVAL PHRTACVRF S HARDPIFGNQ IIPDTAILSV 240 VPPFHGFGMF TTLGYLICGF RVVLMYRFEE ELFLRSLQDY KIQSALLVPT LFSFFAKSTL 300 IDKYDLSNLH EIASGGAPLS KEVGEAVAKR FHLPGIRQGY GLTETTSAIL ITPEGDDKPG 360 AVGKVVPFEE AKVVDLDTGK TLGVNQRGEL CVRGP MIMS G YVNNPEATNA LIDKDGWLHS 420 GDIAYWDEDE HFFIVDLRKS LIKYKGYQVA PAELESILLQ HPNIFDAGVA GLPDDDAGEL 480 PAAVVVLEHG KTMTEKEIVD YVASQVTTAK KLRGGVVVFD EVPKGLTGKL DARKIREILI 540 KAKKGGKIAV 550 </pre>
<p>3-7 3-7-1 3-7-2 3-7-3 3-7-4</p>	<p>Sequences Sequence Number [ID] Molecule Type Length Features Location/Qualifiers</p>	<p>7 RNA 3274 misc_feature 1..3274 note=LacZ nucleotide sequence (5' UTR, ORF, 3' UTR) misc_feature 1..3274</p>

<p>3-7-5</p>	<p>NonEnglishQualifier Value Residues</p>	<p>note=A = AMP, C = CMP, G = GMP, U = N1-methyl-pseudoUMP source 1..3274 mol_type=other RNA organism=synthetic construct</p> <pre>tcaagctttt ggaccctcgt acagaagcta atacgactca ctatagggaa ataagagaga 60 aaagaagagt aagaagaat ataagagcca ccatggcctt ggctgtcgtc ctgcaagaa 120 gagattggga aaatcctgga gttacgcaac tgaatagact cgccgcacat ccaccgttcg 180 cgtcctggcg aaatagcgaa gaagcgcgga ccgacagacc ttgcgacgag ctgcgctctc 240 tcaacgggga atggcggttc gcatggtttc cggctcctga ggcagtcctc gaaagctggc 300 tcgagtgcga cctcccggaa gccgatacgg tgggtgtgcc gtcaaaattgg caaatgcatg 360 gatacgacgc ccccatctac accaacgtca cttacctat caccgtgaat cccccattcg 420 tcccgactga gaaccgact ggatgctaca gcctgacct taacgtggac gagtcgtggc 480 tgcaagaagg gcagactcgc atcattttcg acggagctca ctccgcgctc catctttggt 540 gtaacggacg gtgggtggga tacgggcagg actccaggct gccgagcgaa ttcgacttgt 600 cagccttctt gcgcgcggcg gaaaaccgcc tggctgtcat ggtccttaga tggctgggatg 660 gctcgtacct ggaggatcag gacatgtgga ggatgtcagg gatcttcggg gatgtctcgc 720 tgctccacaa gcccaactacc cagatctccg actttcatgt ggcaccggc ttcaacgatg 780 acttcagcag ggcggttctg gaagccgagg tgcaaatgtg cggagaactg agggactacc 840 tccgcgtgac tgtctcgtc tggcagggtg aaaccaagt ggcttcaggc actgcaccgt 900 tcggaggaga aatcatcgac gaacggggag gatacgcga tcgcgtcacc ctgcgcctca 960 atgtggaaaa tccgaaactg tggtcggcag aaatccctaa tttgtaccgg gccgtgggtg 1020 agctgcacac cgcgcgacga actctgatcg aggcgcaggc atgcgatgtg ggattccgcg 1080 aggtccgcat cgaaaatgga ctgcttctgc ttaatggcaa accgctgctc atccgcggag 1140 tgaacagaca cgagcatcac ccgctgcacg gtcaggtcac ggatgaacag actatggtgc 1200 aagacatcct gctgatgaaa caaaacaact tcaacgcctg tcgggtgctc cattacccta 1260 atcacccgtt gtggtatacc ctttgcgac ggtacggcct ctacgtggg gacgaagcga 1320 acatcgagac tcacggaatg gtccctatga accgcctcac tgacgaccgg aggtggctcc 1380 cggcaatgtc ggaacgagtg actcggatgg tgcagagggg ccgcaaccat ccgtcgggtg 1440 taatctggtc gctgggggaa gaatctggcc acggagctaa ccacgatgct ctgtaccgct 1500 ggattaagt cgtggaccga agccggcccg tccagtaaga aggaggtggt gctgatacca 1560 ctgcaaccga catcatctgc ccaatgtatg cgcgggtgga tgaggaccaa cctttcccgg 1620 cggtgccaaa gtggtccatc aagaaatggc tctcgtgccc cggagaaaac gcgccgctga 1680 tctgtgcca atatgcccac gctatgggaa atcactggg gggatttgcg aagtactggc 1740 aggcttttcg acagtaccgg agactccagg gtggctctgt gtgggactgg gttgaccaga 1800 gcctcatcaa atacgatgaa aacggcaacc catggctccg gtacggcgga gactttggag 1860 acaccctaa cgatcgccag ttctgcatga acggcctggt gttcgcggac agaactccgc 1920 atccagcct tactgaggct aagcaccac aacagttott ccagttcaga ctgtcggggc 1980 aaacgatcga agtgacttcc gaatacctct tccggcaatc ggacaacgag ttgtgcaact 2040 ggatggctgc cctggatgga aagcccctcg cctccggaga agtgccgctc gacgtggcgc 2100 cgcagggaaa gcagttgatc gagttgcccg aactgccaca gcccgagtca gcaggacagc 2160 tctggcttac cgtcagagtc gtgcagccaa atgccaccgc ctggctcggg gcaggacata 2220 tttcagcctg gcagcagtg cgcctcgcgg agaactctgag cgtgaccttg ccagcagcct 2280 cacacgccat tccgcatctg accacgtccg aaatggactt ttgtatcgaa ctgggggaata 2340 agcgttgcca gttcaatcgg caatcaggct tctgtccca gatgtggatt ggtgacaaga 2400 agcagctcct gaccccgctg cgcgatcagt tcaactcgcg cccacttgac aacgacattg 2460 gcgtgagcga ggccacgct atcgatccaa acgcttgggt ggagcgcctg aaggcggctg 2520 gccactatca ggcggaggcc gcgctcctgc agtgtaccg ggataccctc gcagacgccc 2580 ttctgattac cacggcgcag gctggcaac accagggaaa gaccctggtt atcagccgca 2640 aaacttaccg gatcgatggc agcggccaaa tggcgatcac tgtggacgct gaggtggcat 2700 cagacactcc acaccagca cggatcggac tcaattgcca actggctcaa actgctgaga 2760 gagtcgaatt gctgggcctc ggcccccaag agaactacc tgatggctt gtcgcccgat 2820 gctttgaccg gtgggatctg cctctgtcgg atatgtacac cccctacggt ttcccatccg 2880 agaacggtct gagatgcggt actagggagt tgaactacgg accgcaccaa tggagggggg 2940 actttcagtt caacatctca agatacagcc agcagcaatt gatggaacc tcgcaccggc 3000 atctcttga tgacagggaa gggacctggc tgaacatcga tggattccac atgggaattg 3060 gtggggatga ctctggctc cctagcgtgt ccgcggaact tcagctgtcc gccggccggt 3120 accactacca gctcgtgtgt tgtcaaaagt gataataggg tggagcctcg gtggccatgc 3180 ttcttgccc ttgggcctcc ccccagccc tctcccctt cctgcaccgg taccoccggt 3240 gtcttgaat aaagtctgag tgggcggctc taga 3274</pre>
<p>3-8 3-8-1 3-8-2 3-8-3 3-8-4</p>	<p>Sequences Sequence Number [ID] Molecule Type Length Features Location/Qualifiers</p>	<p>8 AA 1019 REGION 1..1019 note=LacZ source 1..1019 mol_type=protein organism=synthetic construct</p>
<p>3-8-5</p>	<p>NonEnglishQualifier Value Residues</p>	<pre>MALAVVLQRR DWENPGVTQL NRLAAHPFFA SWRNSEART DRPSQQLRSL NGEWRFAWFP 60 APEAVPESWL ECDLPEADTV VVPSNWQMHG YDAPIYTNVT YPITVNPPFV PTENPTGCYS 120 LTFNVDESWL QEQQTRIFD GVNSAFHLWC NGRVWVGQD SRLPSEFDLS AFLRAGENRL 180 AVMVLRWSDG SYLEDQDMWR MSGIFRDVSL LHKPTTQISD FHVATRFNDD FSRVLEAEV 240</pre>

		<p>QMCGELRDYL RVTVSLWGE TQVASGTAPF GGEIIDERGG YADRVTLRLN VENPKLWSAE 300</p> <p>IPNLYRAVVE LHTADGTLIE AEACDVGFRE VRIENGLLLL NGKPLLRIGV NRHEHPLHG 360</p> <p>QVMDEQTMVQ DILLMKQNNF NAVRCSHYPN HPLWYTLCDR YGLYVVDEAN IETHGMVPMN 420</p> <p>RLTDDPRWLP AMSERVTRMV QRDRNHPSVI IWSLGNESGH GANHDALYRW IKSVDPSRPV 480</p> <p>QYEGGGADTT ATDIICPMYA RVDEDQPPA VPKWSIKKWL SLPGETRPLI LCEYAHAMGN 540</p> <p>SLGGFAKYWQ AFRQYPRLQG GFVWDWVDQS LIKYDENGPN WSAYGGDFGD TPNDRQFCMN 600</p> <p>GLVFADRTPH PALTEAKHQQ QFFQFRLSGQ TIEVTSEYLF RHSDNELLHW MVALDGKPLA 660</p> <p>SGEVPLDVAP QGQLIELPE LPQPEASGQL WLTVRVVPN ATAWSEAGHI SAWQQWRLAE 720</p> <p>NLSVTLPAAS HAIPHLTSE MDFCIELGNK RWQFNRSQSF LSQMWIGDKK QLLTPLRDQF 780</p> <p>TRAPLDNDIG VSEATRDPN AWVERWKAAG HYQAEALLQ CTADTLADAV LITTAHAWQH 840</p> <p>QGKTLFISRK TYRIDGSGQM AITVDVEVAS DTPHPARIGL NCQLAQAER VNWGLGQPQE 900</p> <p>NYPDRLTAAC FDRWDLPLSD MYTPYVFPSE NGLRCGTREL NYGPHQWRGD FQFNISRYSQ 960</p> <p>QQLMETSHRH LLHAEETWLV NIDGFHMIG GDDSWSPSVS AELQLSAGRY HYQLVWCQK 1019</p>
3-9	Sequences	
3-9-1	Sequence Number [ID]	9
3-9-2	Molecule Type	RNA
3-9-3	Length	3057
3-9-4	Features	misc_feature 1..3057
	Location/Qualifiers	note=LacZ ORF nucleotide sequence
		misc_feature 1..3057
		note=A = AMP, C = CMP, G = GMP, U = N1-methyl-pseudoUMP
		source 1..3057
		mol_type=other RNA
		organism=synthetic construct
3-9-5	NonEnglishQualifier Value Residues	<p>atggccttg ctgtcgtcct gcaagaaga gattgggaaa atcctggagt tacgcaactg 60</p> <p>aatagactcg ccgcacatcc accgttcgcg tcctggcgaa atagcgaaga agcgcggacc 120</p> <p>gacagacctt cgcagcagct gcgctctctc aacggggaat ggcggttcgc atggtttccg 180</p> <p>gctcctgagg cagtcccgga aagctggctc gactgagcag tcccggaagc cgatccggtg 240</p> <p>gtggtgcccgt caaattggca aatgcatgga tacgacgccc ccatctacac caacgtcaact 300</p> <p>taccctatca ccgtgaatcc cccattcgtc ccgactgaga acccgactgg atgctacagc 360</p> <p>ctgaccttta acgtggacga gtcgtggctg caagaagggc agactcgcac cttttcgcac 420</p> <p>ggagtcaact ccgcttcca tctttggtgt aacggacggt ggggtgggata cgggcaggac 480</p> <p>tccaggctgc cgagcgaatt cgacttgcga gccttctcgc gcgcccgcga aaaccgcctg 540</p> <p>gctgtcatgg tccttagatg gtcggatggc tcgtacctgg aggatcagga catgtggagg 600</p> <p>atgtcaggga tcttcggga tgtctcgtg ctccacaag caactaccga gatctccgac 660</p> <p>tttcatgtgg ccaccgctt caacgatgac ttcagcagg ccggttctgga agccgaggtg 720</p> <p>caaatgtgcg gagaactgag ggactacctc cgcgtgactg tctcgtctcg gcagggtgaa 780</p> <p>acccaagtgg cttcaggcac tgcaccgttc ggaggagaaa tcatcgacga acggggagga 840</p> <p>tacgccgatc gcgtcacctt gcgcctcaat gtggaaaatc gaaaactgtg gtcgagcaga 900</p> <p>atccctaatt tgtaccgggc cgtgggtggag ctgcacaccg ccgacggaac tctgatcgag 960</p> <p>gccgagggat gcgatgtggg attccgcgag gtccgcacgc aaaatggact gcttctgctt 1020</p> <p>aatggcaaac cgctgctcat ccgcccagtg aacagacag agcatcaccg gctgcacggg 1080</p> <p>caggtcatgg atgaacagac tatggtgcaa gacatcctgc tgatgaaaca aaacaacttc 1140</p> <p>aacgccgttc ggtgctcca ttaccctaat caccgctgtt ggtataacct ttgcatcg 1200</p> <p>tacggcctct acgtggtgga cgaagcgaac atcgagactc acggaatggt ccctatgaac 1260</p> <p>cgctcactg acgacccgag gtggtcccgc gcaatgtcgg aacgagtgac tcggatgggtg 1320</p> <p>cagagggacc gcaacctacc gtcgggtgata atctggtcgc tggggaaacga atctggccac 1380</p> <p>ggagctaac acgatgcctt gtaccgctgg attaagtccg tggaccgaag ccggcccctg 1440</p> <p>cagtacgaag gaggtggtgc tgataccact gcaaccgca tcactctgcc aatgatcgct 1500</p> <p>cgggtggatg aggaccaacc tttcccggcg gtgcccgaagt ggtccatcaa gaaatggctc 1560</p> <p>tcgctgcccg gagaaacgcg cccgctgacg ctgtgcgaat atgcgcacgc tatgggaaaat 1620</p> <p>tactggggg gatctgcgaa gtactggcag gcttttcgac agtaccgag actccagggt 1680</p> <p>ggcttcgtgt gggactgggt tgaccagagc ctcatcaaat acgatgaaaa cggcaaccga 1740</p> <p>tggtccgctg acggcggaga ctttggagac acccctaacg atcgccagtt ctgcatgaac 1800</p> <p>ggcctggtg tcgccgacag aactccgcac ccagccctta ctgaggctaa gcaccaacaa 1860</p> <p>cagttcttcc agttcagact tccggggcaa acgatcgaag tgactctcca atacctctt 1920</p> <p>cggcattcgg acaacgagtt gctgcaactg atggtcggcc tggatggaaa gccctcgc 1980</p> <p>tccggagaag tgcgctcga cgtggcgccg cagggaaagc agttgatcga gttgcccggaa 2040</p> <p>ctgccacagc ccgagtcagc aggacagctc tggcttaacc tcagagtcgt gcagccaaat 2100</p> <p>gccaccgcct ggtcggaggc aggacatatt tcagcctggc agcagtgagg cctcgcggag 2160</p> <p>aatctgagcg tgaccttgcc agcagcctca cacgccattc cgcactctga cacgtccgaa 2220</p> <p>atggactttt gtatcgaact ggggaataag cgctggcagt tcaactcggc atcaggttc 2280</p> <p>ctgtoccaga tgtggattgg tgacaagaag cagctcctga ccccgctcgc cgcactgttc 2340</p> <p>actcgcgccc cacttgacaa cgacattggc gtgagcgagg ccacgcgtat cgatccaaac 2400</p> <p>gcttgggtgg agcgtggaag ggcggctggc cactatcagg cggaggccgc gctcctcgag 2460</p> <p>tgtaccgcyg ataccctcgc agacgcccgt ctgattacca cggcgcatgc ctggcaacac 2520</p> <p>cagggaaaaga ccctgtttat cagccgcaaa acttaccgga tcgatggcag cggccaaatg 2580</p> <p>gcgatcactg tggacgtcga ggtggcatca gacactccac acccagcagc gatcggactc 2640</p> <p>aattgccaac tggctcaagt ggctgagaga gtcaattggc tgggctcggc cccccaagag 2700</p> <p>aactaccctg atcggcttac tgccgcatgc tttgaccggt gggatctgcc tctgtcggat 2760</p> <p>atgtacaccc cctacgtgtt cccatccgag aacggctcga gatgcggtag tagggagttg 2820</p> <p>aactacggac cgcaccaatg gaggggggac tttcagttca acatctcaag atacagccag 2880</p> <p>cagcaattga tggaaacctc gcaccgcat ctcttgcagt cagaggaagg gacctggctg 2940</p>

2023208200

28 Jul 2023

		aacatcgatg gattccacat ggaattggt ggggatgact cctgggtccc tagcgtgtcc 3000
		gcggaacttc agctgtccgc cggccggtac cactaccagc tcgtgtggtg tcaaaag 3057