



US011809127B2

(12) **United States Patent**
Kawanami et al.

(10) **Patent No.:** **US 11,809,127 B2**

(45) **Date of Patent:** **Nov. 7, 2023**

(54) **IMAGE FORMING APPARATUS HAVING IMPROVED MOUNTABILITY OF A CARTRIDGE WHILE CONSERVING SPACE**

(58) **Field of Classification Search**

CPC G03G 21/1609; G03G 21/1652; G03G 21/1814; G03G 21/1842; G03G 21/1853;
(Continued)

(71) Applicant: **CANON KABUSHIKI KAISHA**,
Tokyo (JP)

(56) **References Cited**

(72) Inventors: **Takeo Kawanami**, Kanagawa (JP);
Kazuaki Nogami, Saitama (JP);
Takehiro Hayashi, Kanagawa (JP);
Kenji Watanabe, Shizuoka (JP);
Shunsuke Hijikata, Kanagawa (JP)

U.S. PATENT DOCUMENTS

7,599,640 B2 10/2009 Sato
8,290,395 B2 10/2012 Uchida
(Continued)

(73) Assignee: **CANON KABUSHIKI KAISHA**,
Tokyo (JP)

FOREIGN PATENT DOCUMENTS

(*) Notice: Subject to any disclaimer, the term of this patent is extended or adjusted under 35 U.S.C. 154(b) by 0 days.

EP 3699693 A1 8/2020
JP H10301465 A 11/1998
(Continued)

OTHER PUBLICATIONS

(21) Appl. No.: **17/981,740**

Combined Search and Examination Report issued in GB Appln. No. 2111391.5 dated Jan. 26, 2022.

(22) Filed: **Nov. 7, 2022**

(Continued)

(65) **Prior Publication Data**

US 2023/0059386 A1 Feb. 23, 2023

Related U.S. Application Data

(63) Continuation of application No. 17/397,054, filed on Aug. 9, 2021, now Pat. No. 11,526,124.

Primary Examiner — Sophia S Chen

(74) *Attorney, Agent, or Firm* — ROSSI, KIMMS & McDOWELL LLP

(30) **Foreign Application Priority Data**

Aug. 12, 2020 (JP) 2020-136143
Aug. 12, 2020 (JP) 2020-136209
Aug. 12, 2020 (JP) 2020-136229

(57) **ABSTRACT**

In an image forming apparatus, a tray unit to which a cartridge is detachably mounted, and that is configured to be capable of moving between an internal position situated within the apparatus main body and an external position situated outside, includes first and second side plates configured to support the cartridge, and they are each made of metal, and include a supporting portion and an outer side portion, the supporting portions includes positioning portions configured to come into contact with the cartridge to position the cartridge as to an image forming position. The apparatus main body includes first and second pressing members each capable of moving between pressing positions at which the cartridge is pressed, and separated positions separated from the cartridge. The first and second

(Continued)

(51) **Int. Cl.**
G03G 21/16 (2006.01)
G03G 21/18 (2006.01)

(52) **U.S. Cl.**
CPC **G03G 21/1853** (2013.01); **G03G 21/1652** (2013.01); **G03G 21/1814** (2013.01); **G03G 21/1842** (2013.01); **G03G 2221/1869** (2013.01)

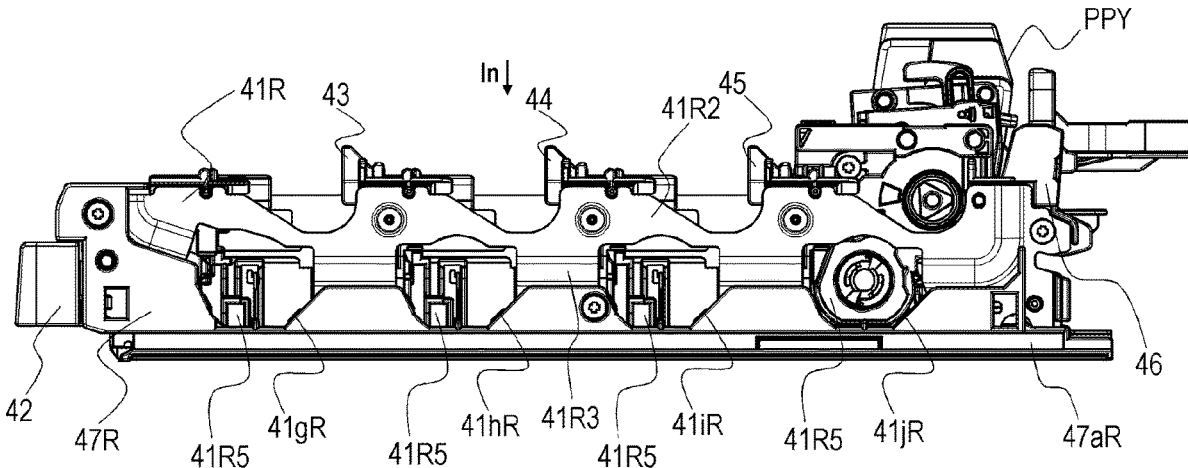

pressing members are disposed each intersecting with imaginary planes that is orthogonal to the longitudinal direction and intersect the positioning portions.

2010/0111562 A1 5/2010 Okabe
2010/0239314 A1 9/2010 Takayama
2018/0052423 A1* 2/2018 Hwang G03G 21/1867

45 Claims, 20 Drawing Sheets

FOREIGN PATENT DOCUMENTS

(58) **Field of Classification Search**

CPC G03G 21/1867; G03G 21/1878; G03G 2221/1684; G03G 2221/1869

See application file for complete search history.

JP 2007148287 A 6/2007
JP 2008165026 A 7/2008
JP 2010102303 A 5/2010
JP 2010107888 A 5/2010
JP 2016114620 A 6/2016
JP 2016224083 A 12/2016

(56)

References Cited

U.S. PATENT DOCUMENTS

8,301,054 B2 10/2012 Tanabe
9,857,761 B2 1/2018 Osawa
2007/0160380 A1 7/2007 Imaizumi
2007/0280730 A1 12/2007 Okabe

OTHER PUBLICATIONS

Office Action issued in U.S. Appl. No. 17/397,054 dated May 20, 2022.

Notice of Allowance issued in U.S. Appl. No. 17/397,054 dated Aug. 30, 2022.

* cited by examiner

FIG. 1

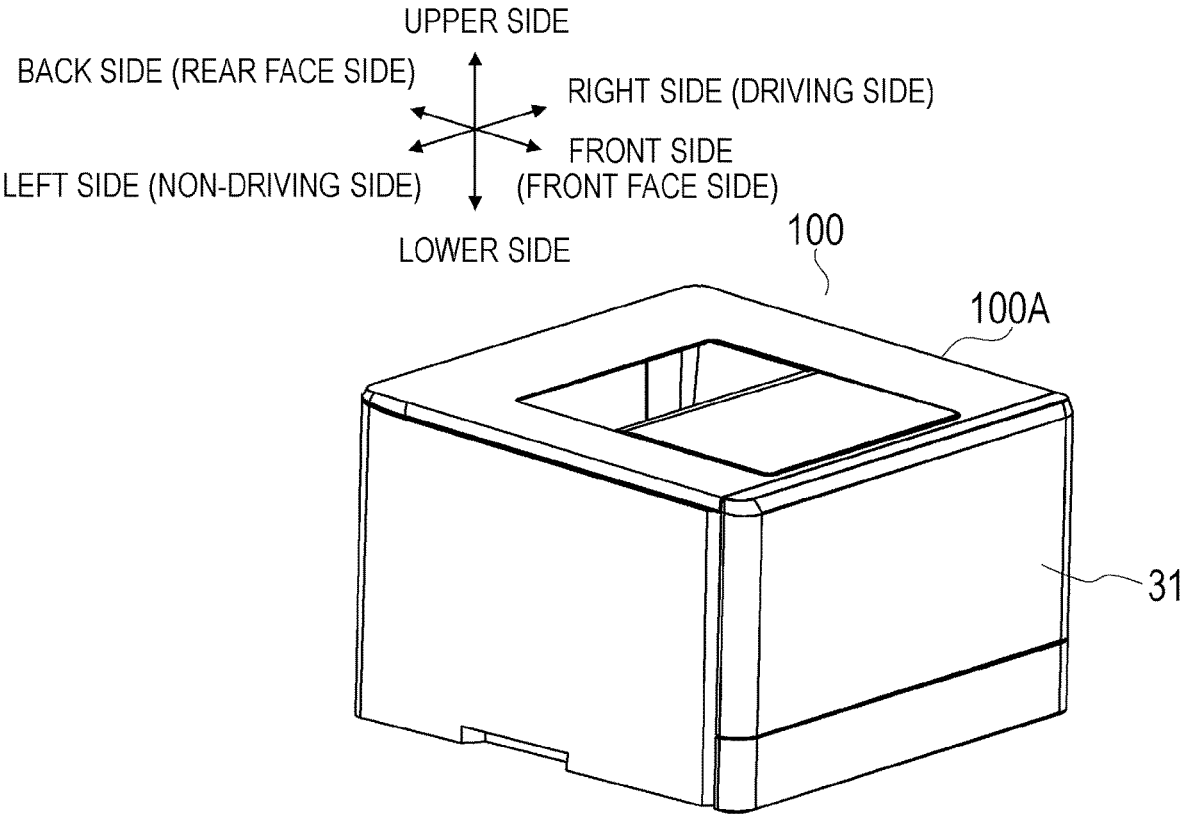

FIG. 2

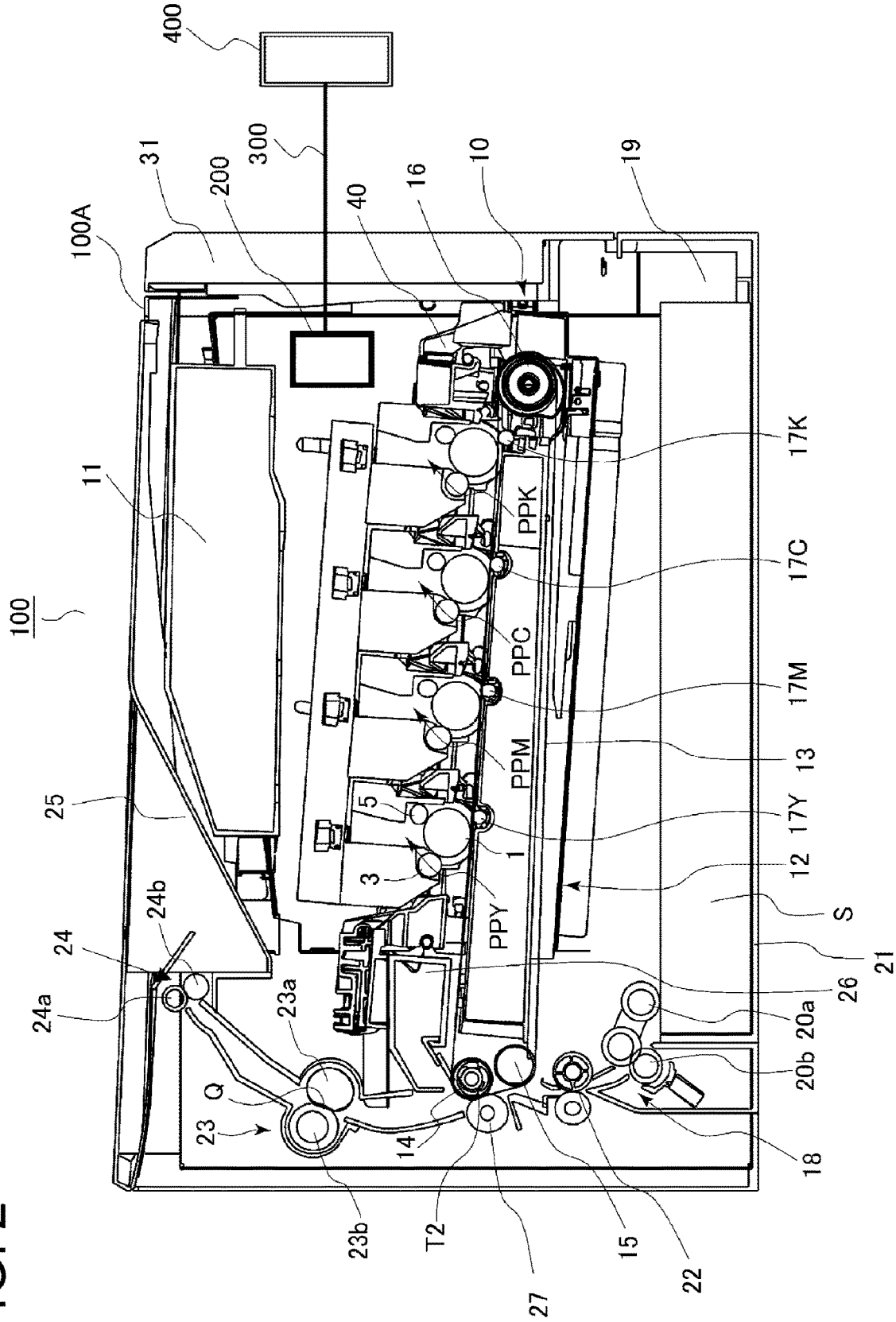

FIG. 3A

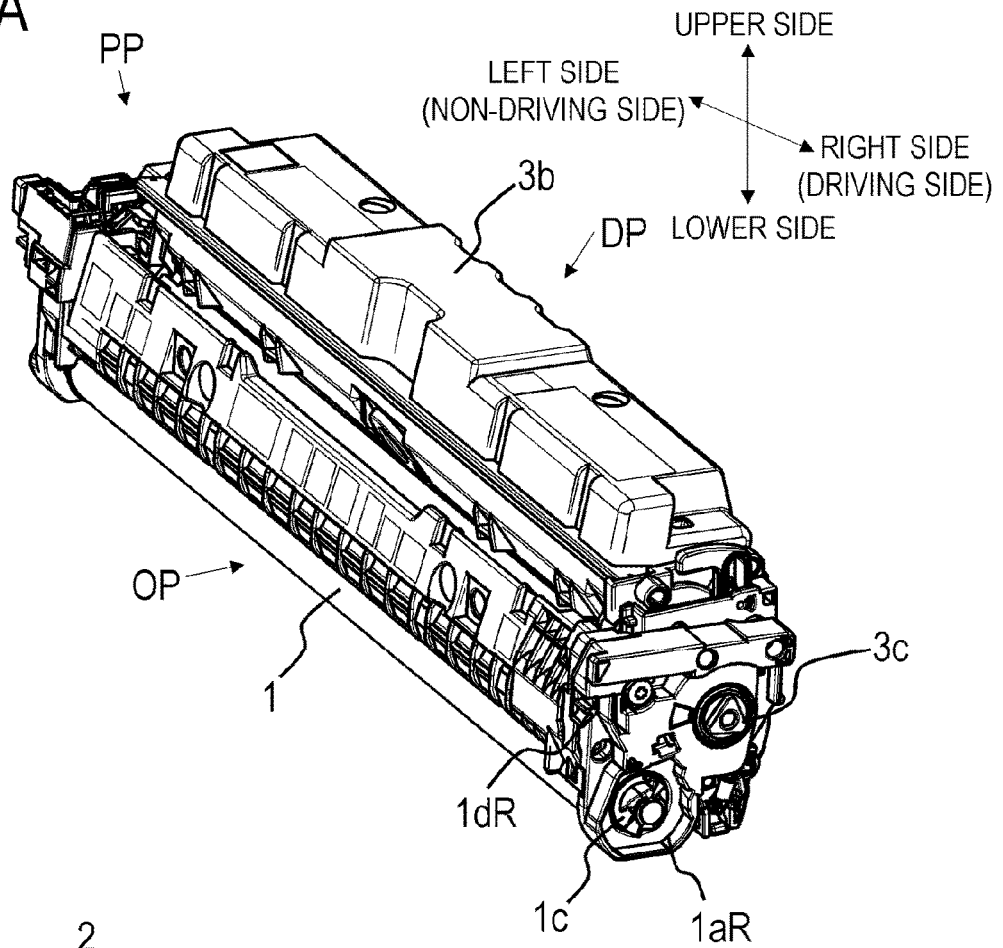

FIG. 3B

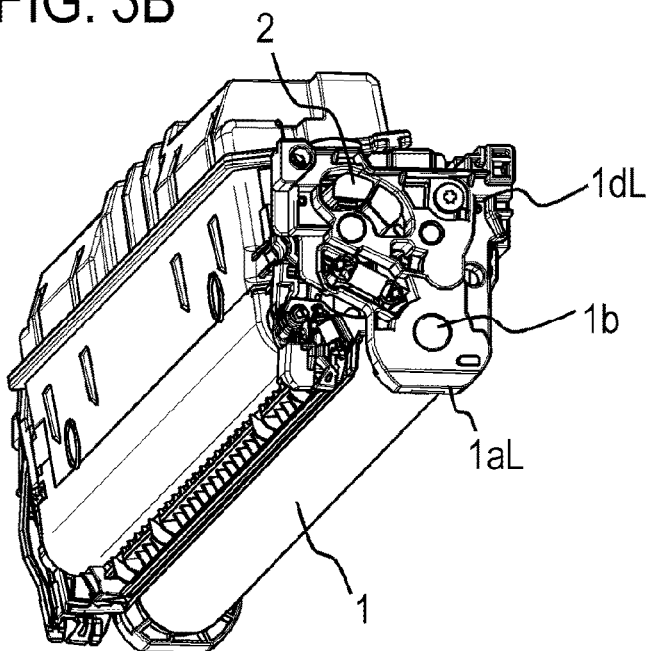

FIG. 4A

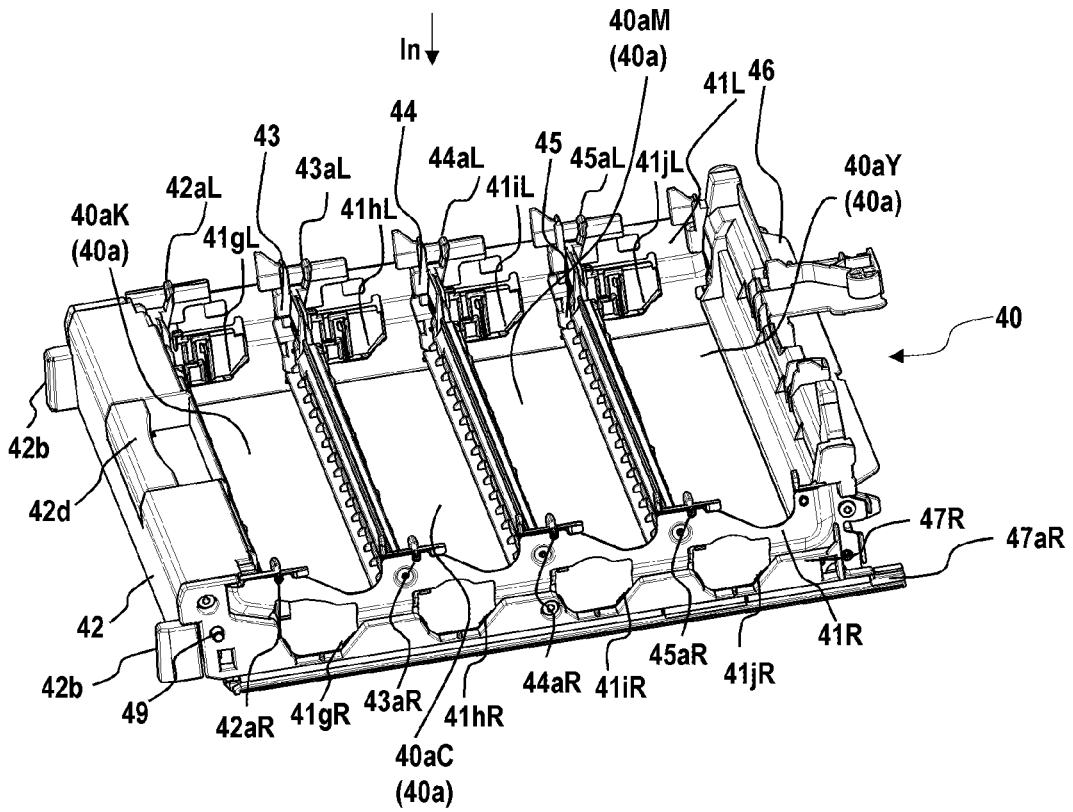

FIG. 4B

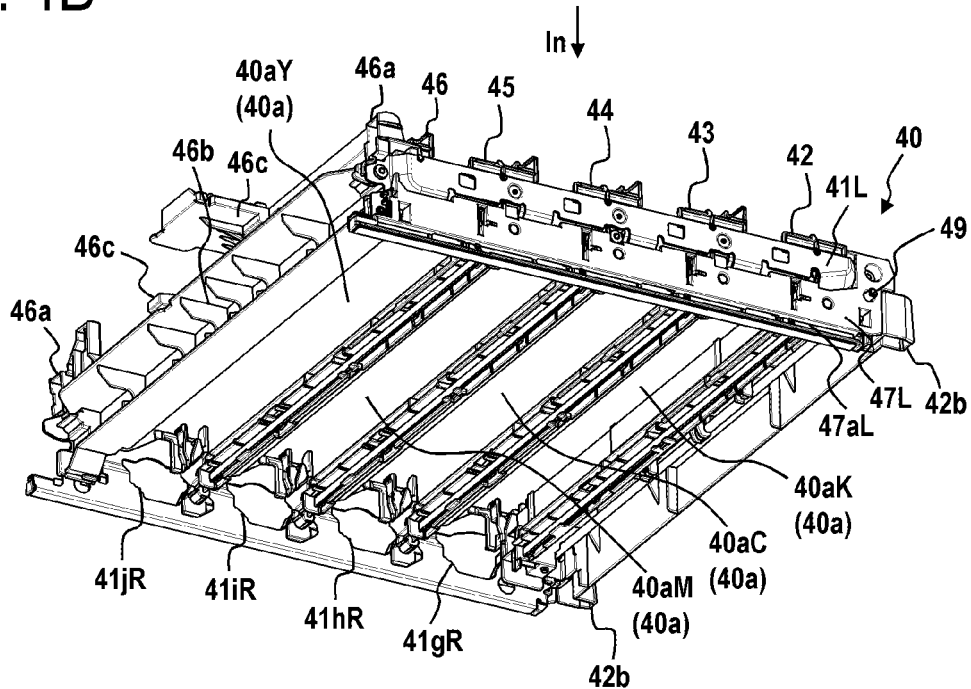

FIG. 5A

PP(PPY,PPM,PPC,PPK)

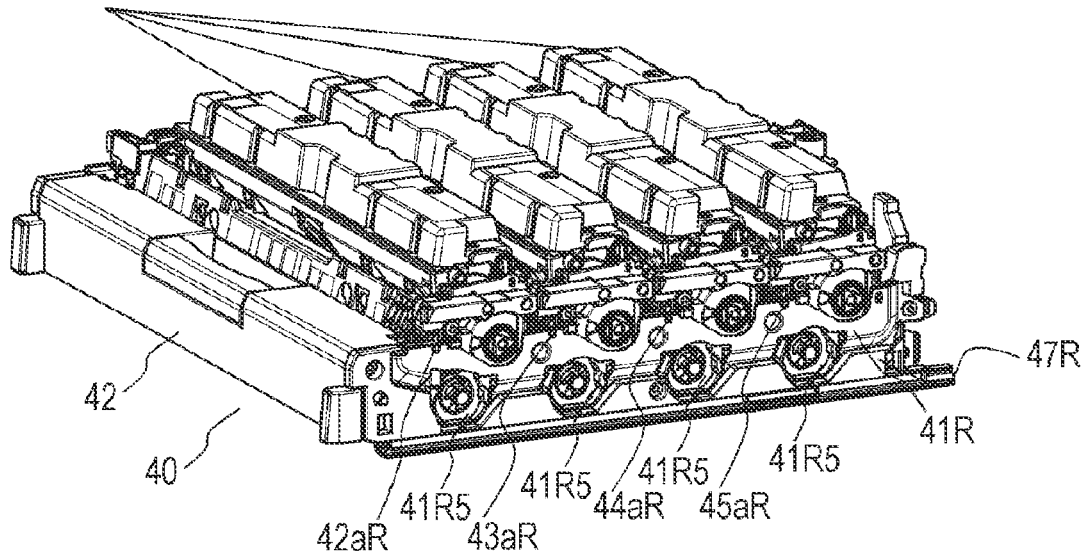

FIG. 5B

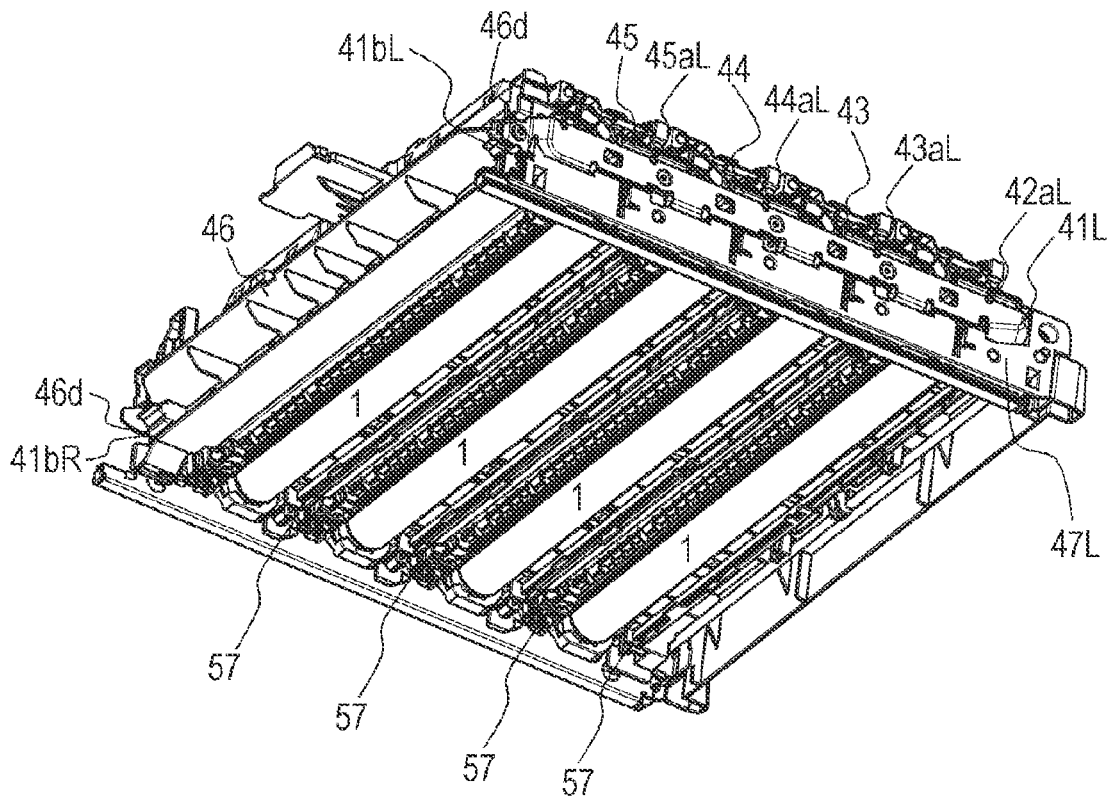

FIG. 6A

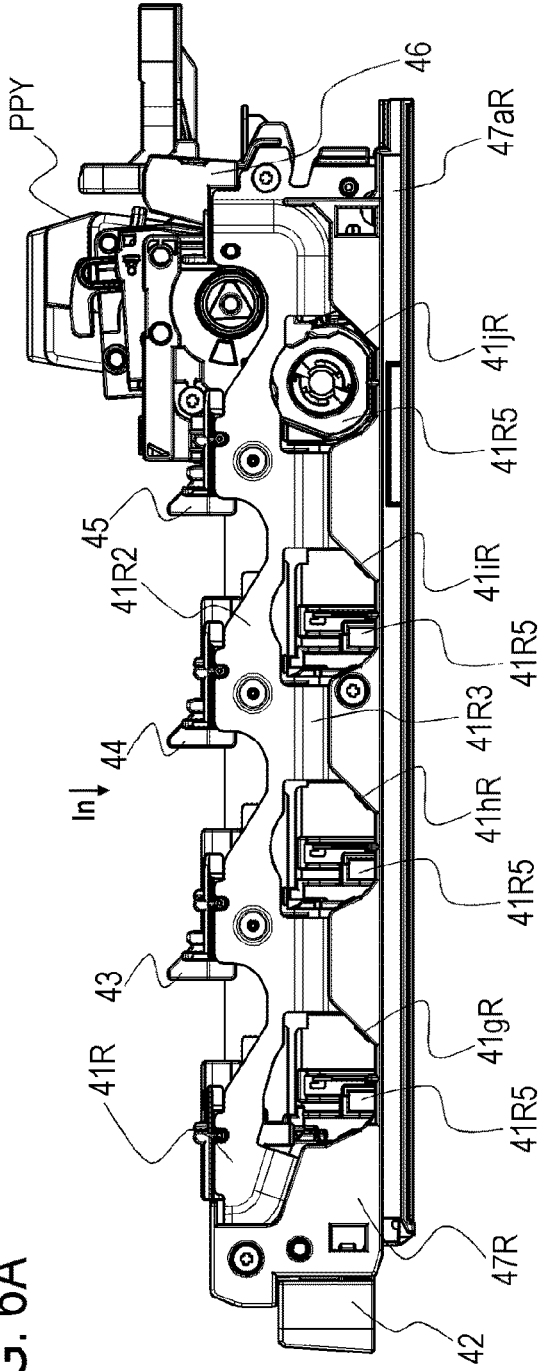

FIG. 6B

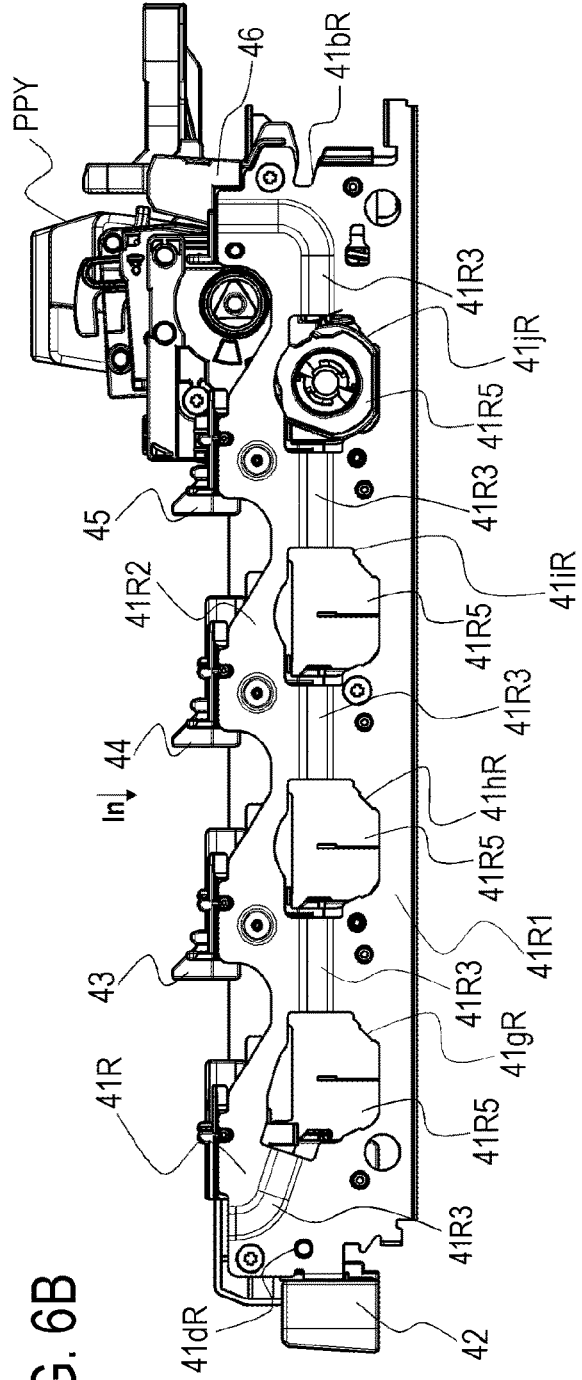

FIG. 7A

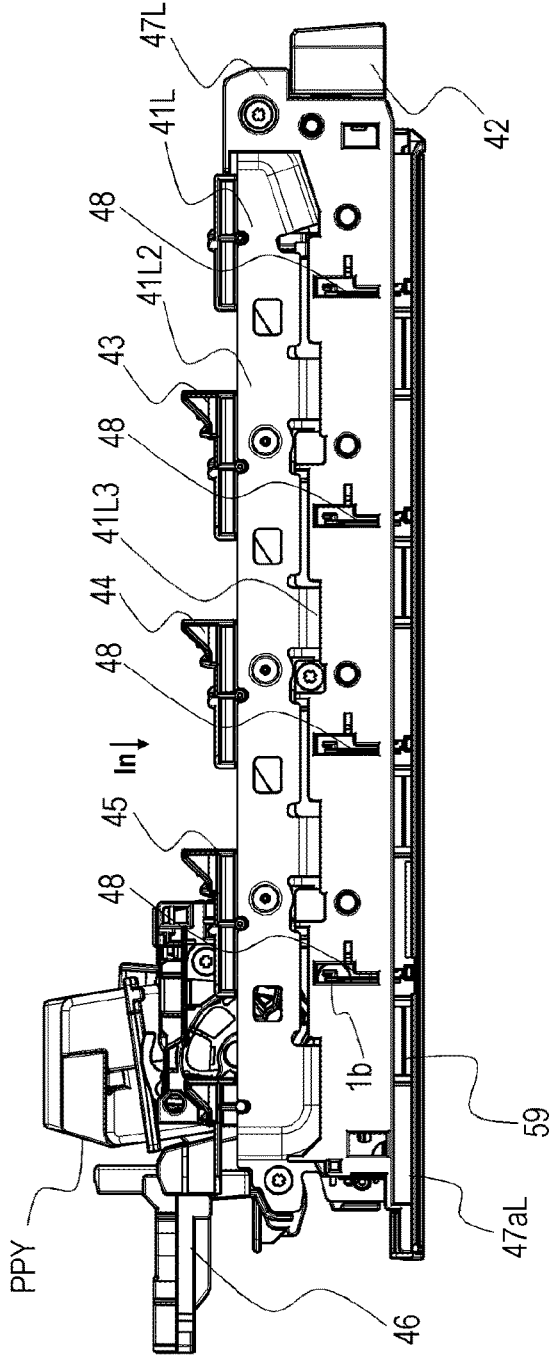

FIG. 7B

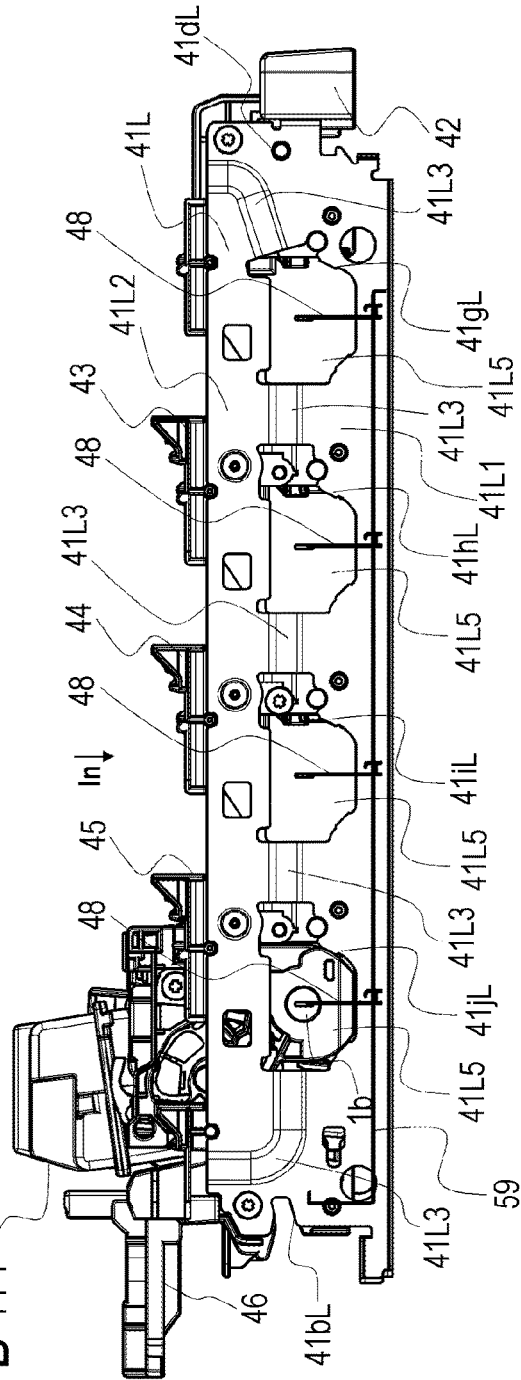

FIG. 8

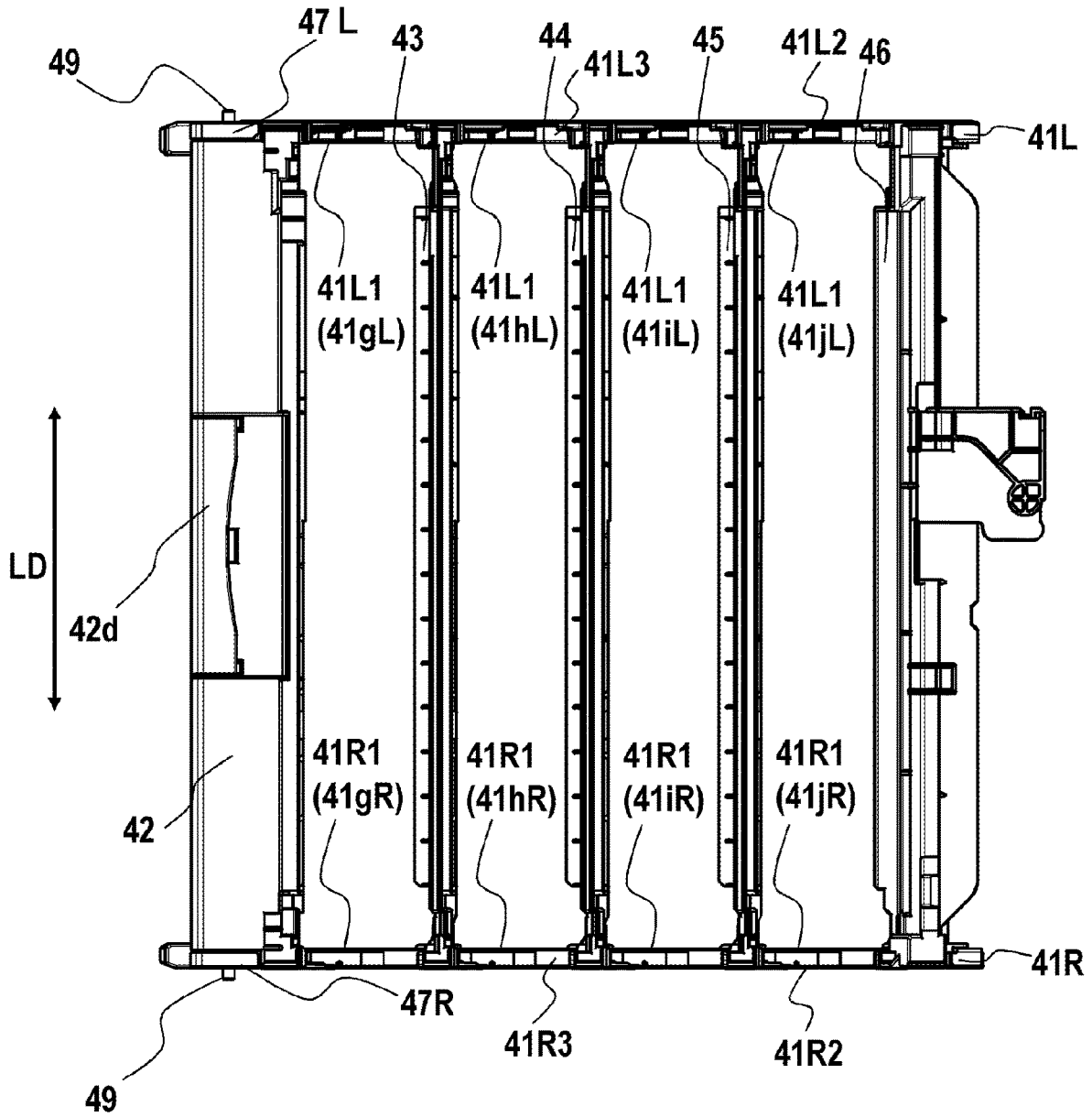

FIG. 9

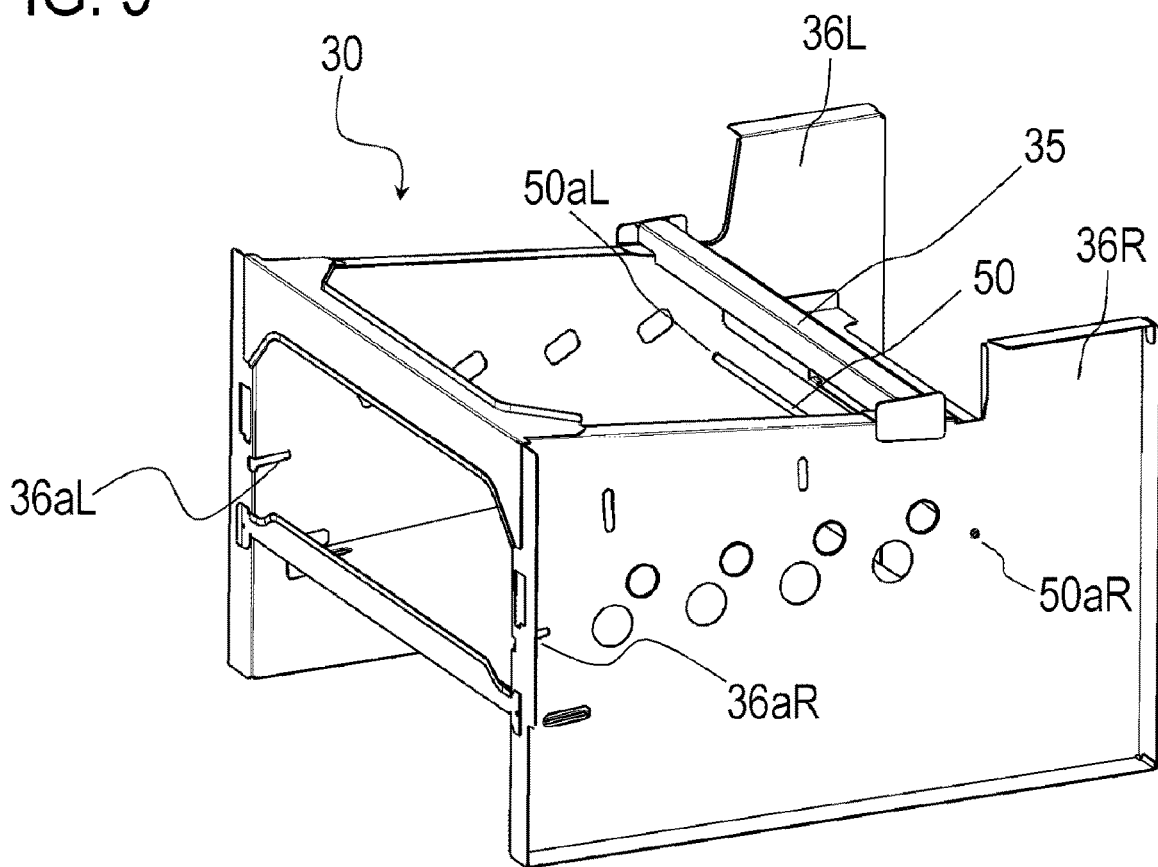

FIG. 10

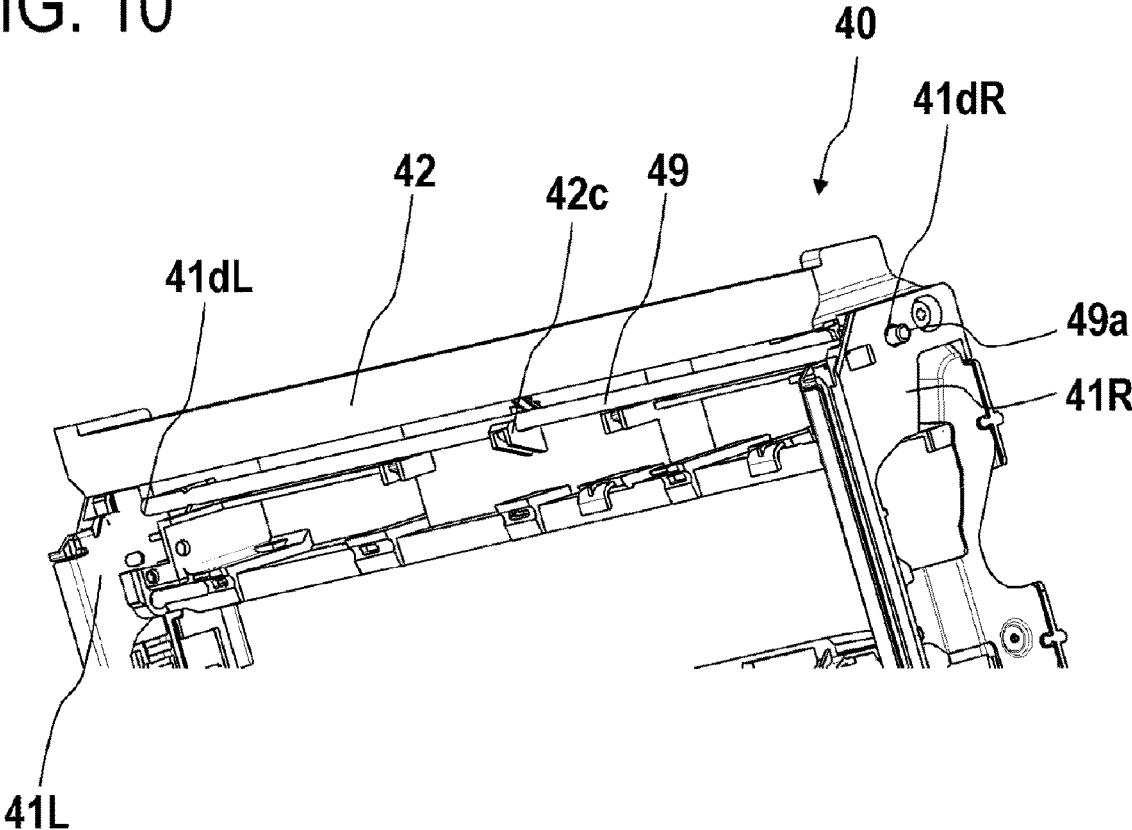

FIG. 11A

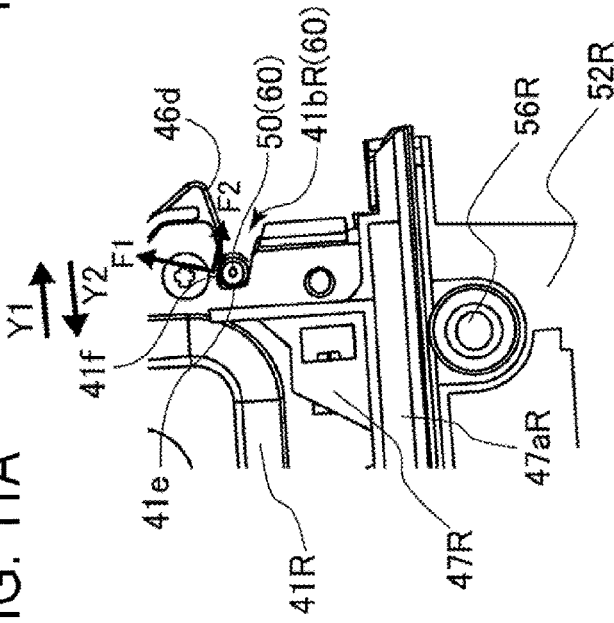

FIG. 11B

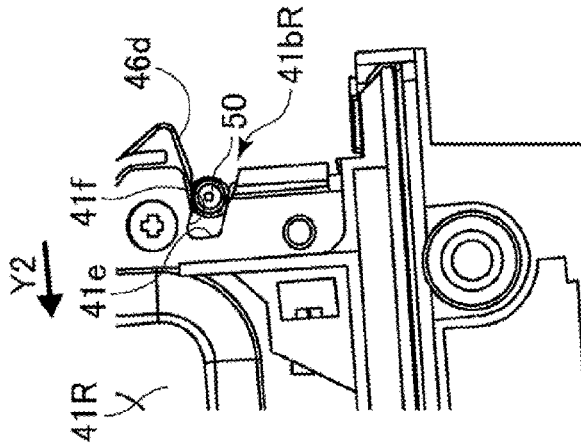

FIG. 11C

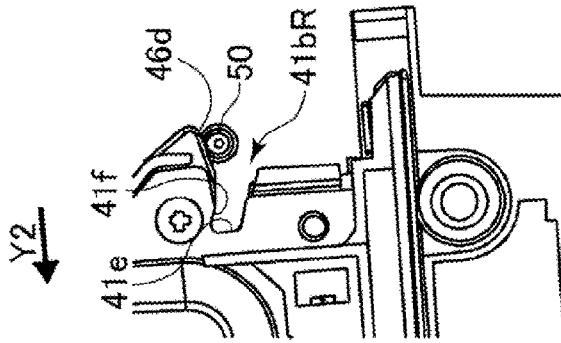

FIG. 11D

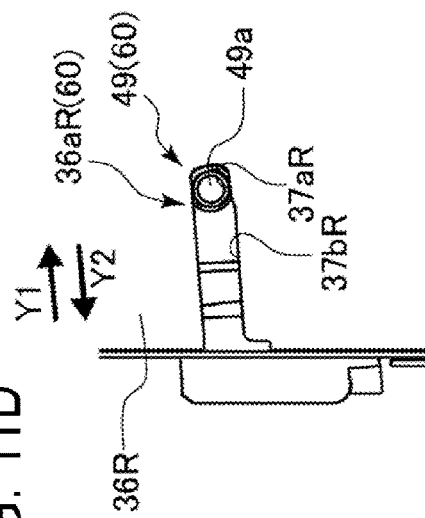

FIG. 11E

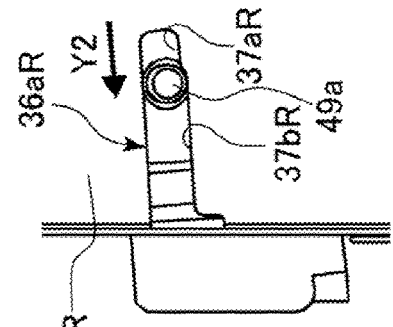
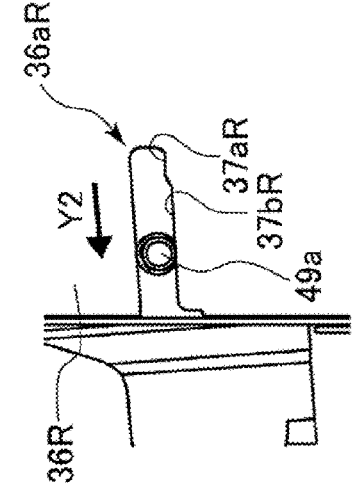

FIG. 11F



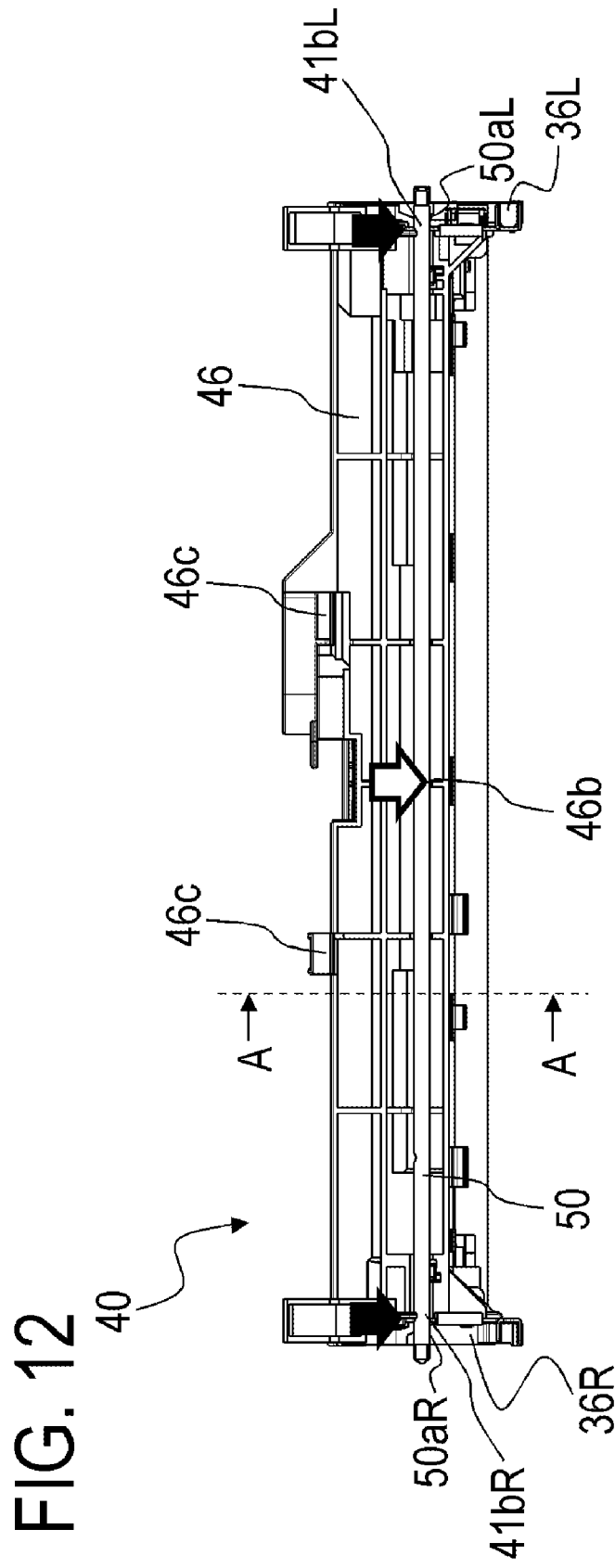

FIG. 12

FIG. 13

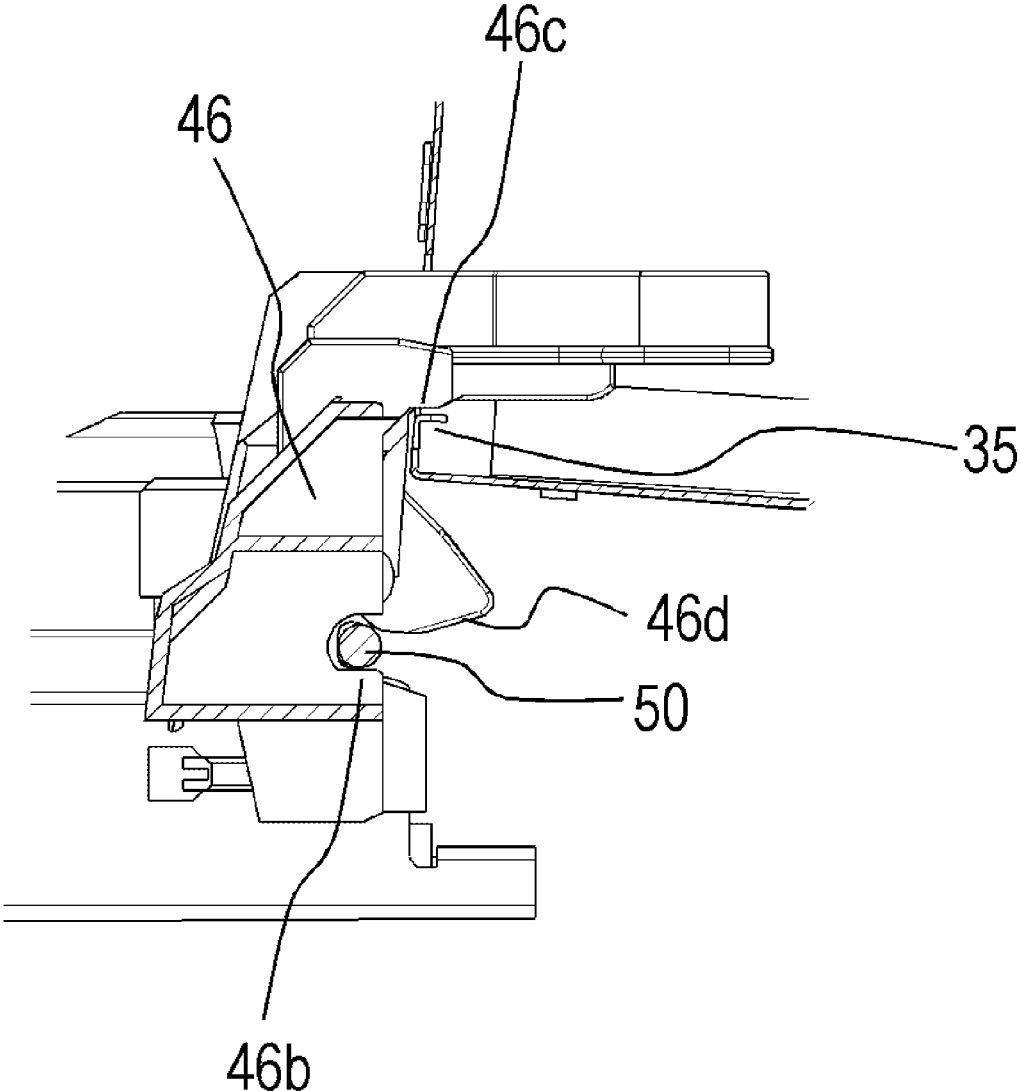

FIG. 14A

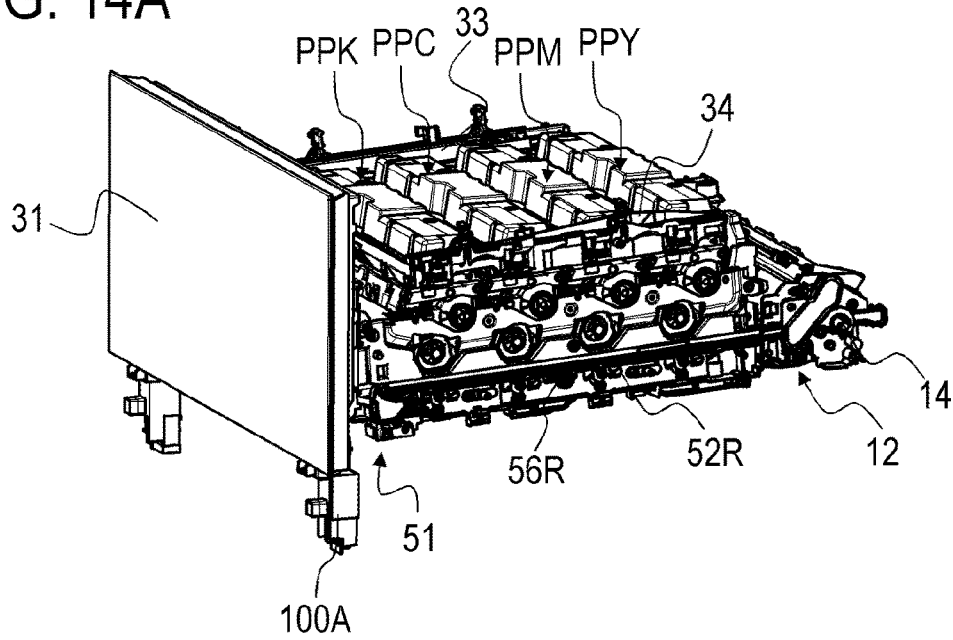

FIG. 14B

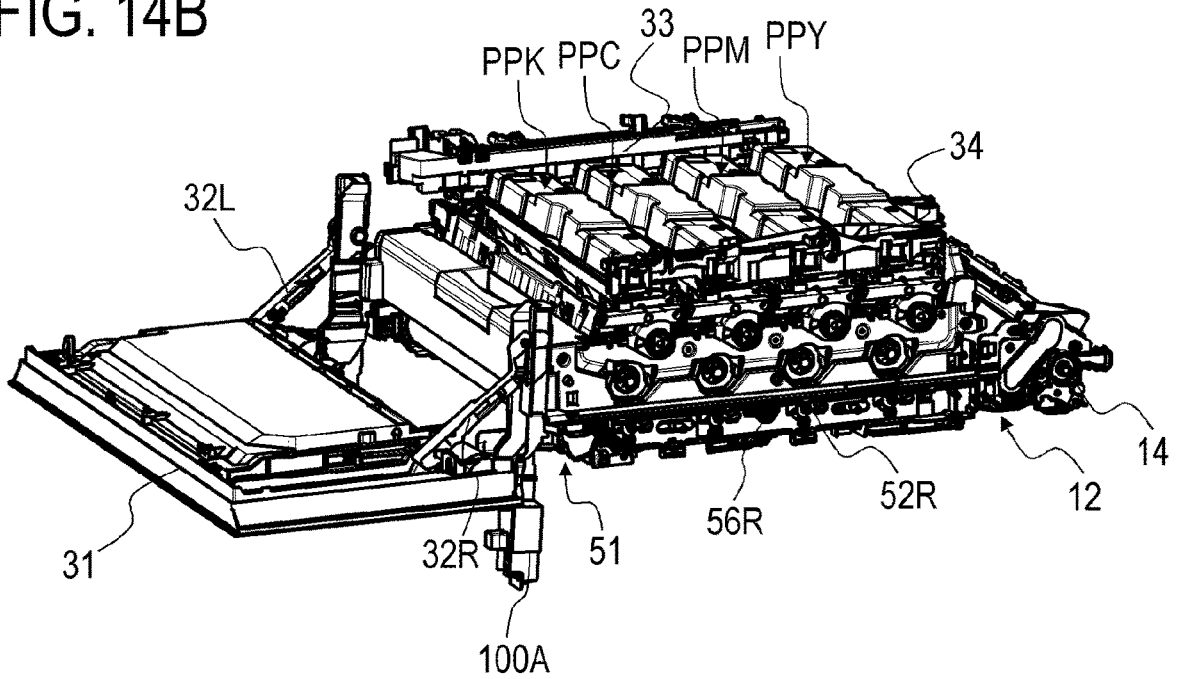

FIG. 15A

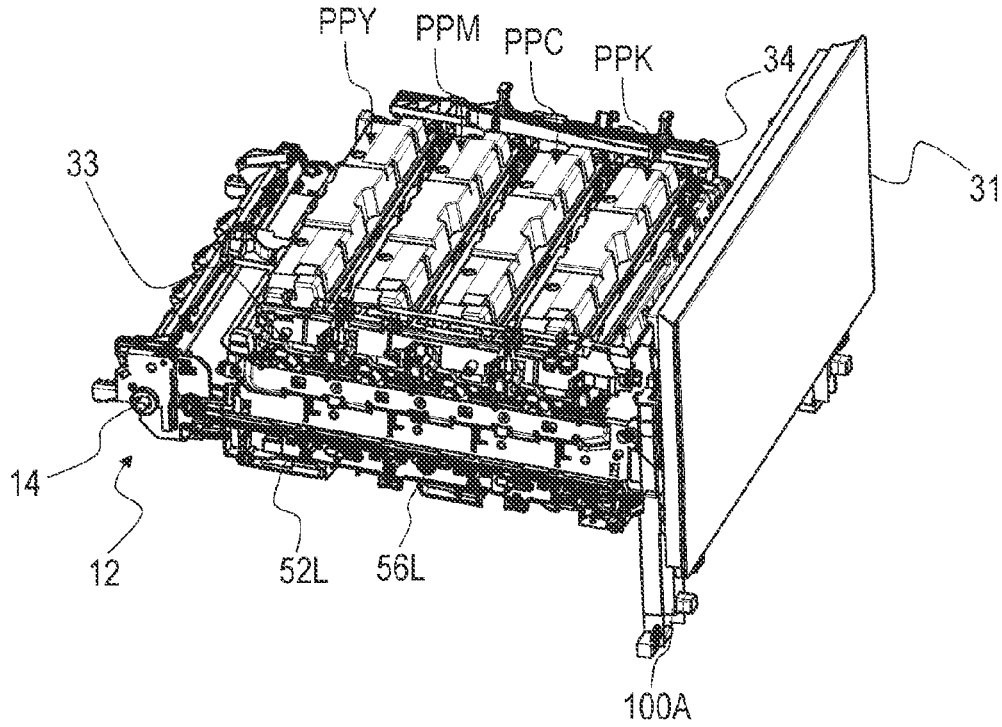

FIG. 15B

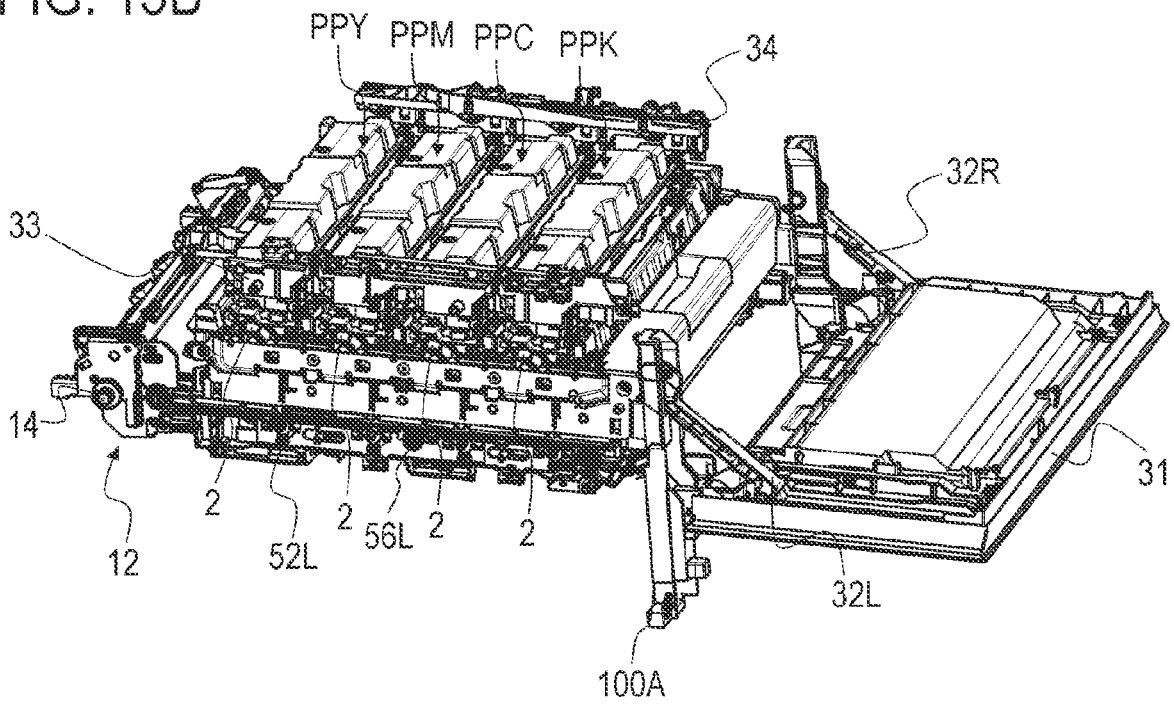

FIG. 16A

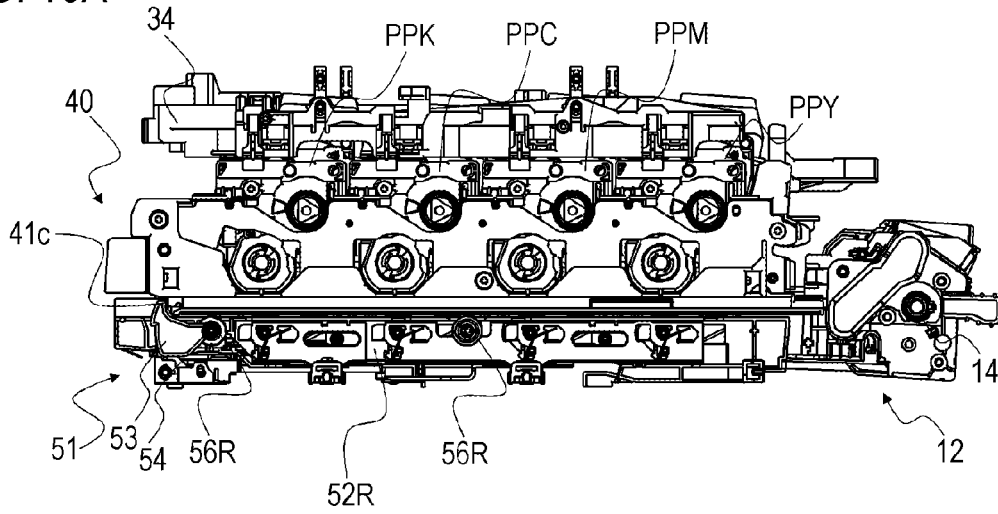

FIG. 16B

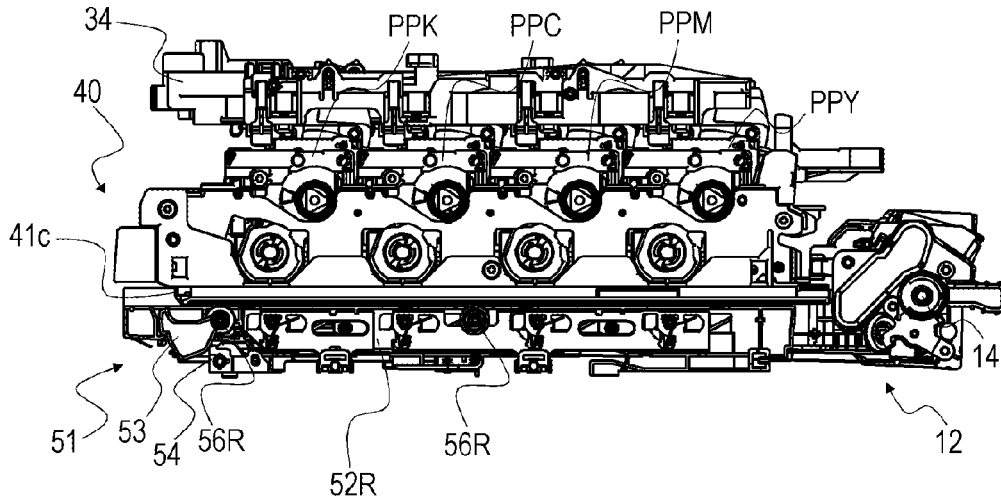

FIG. 16C

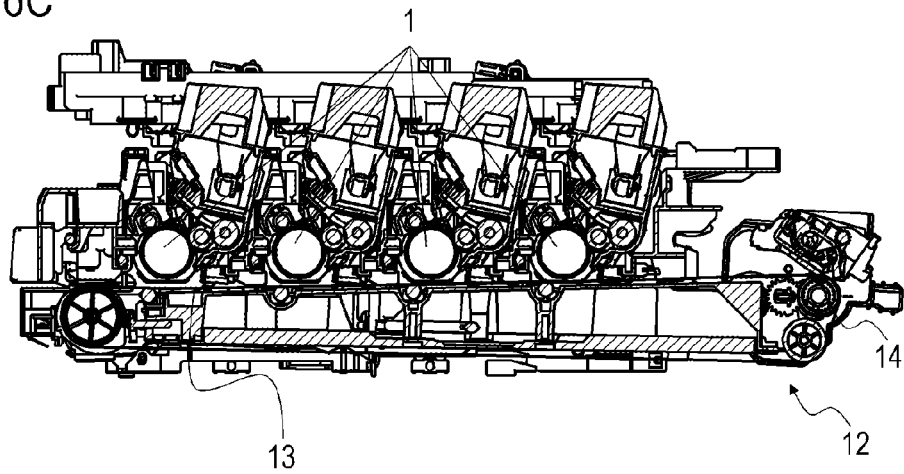

FIG. 17A

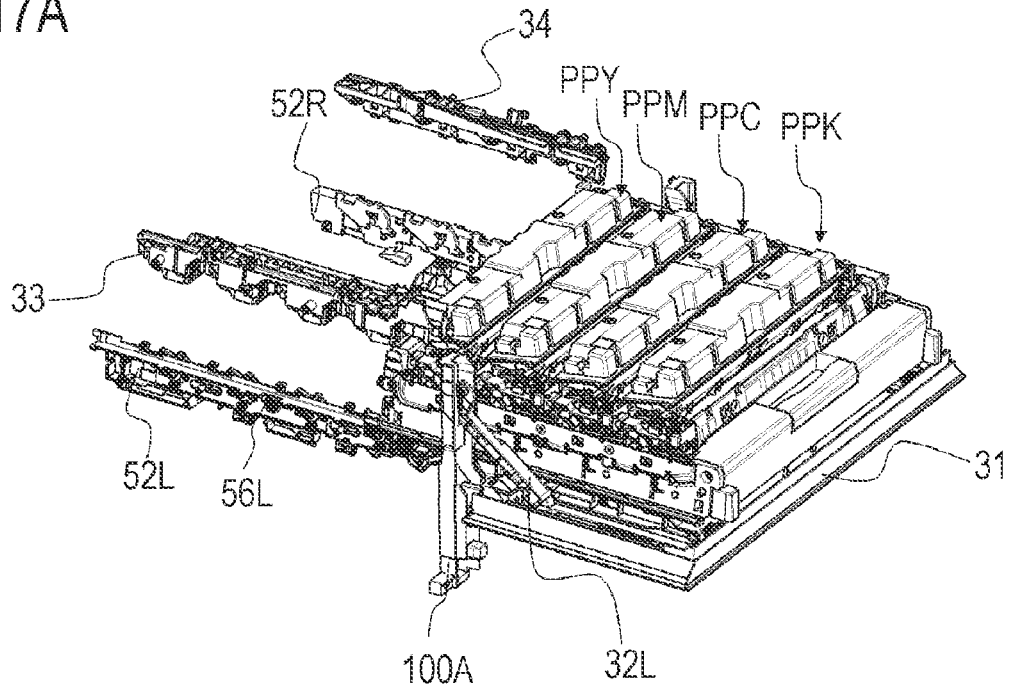

FIG. 17B

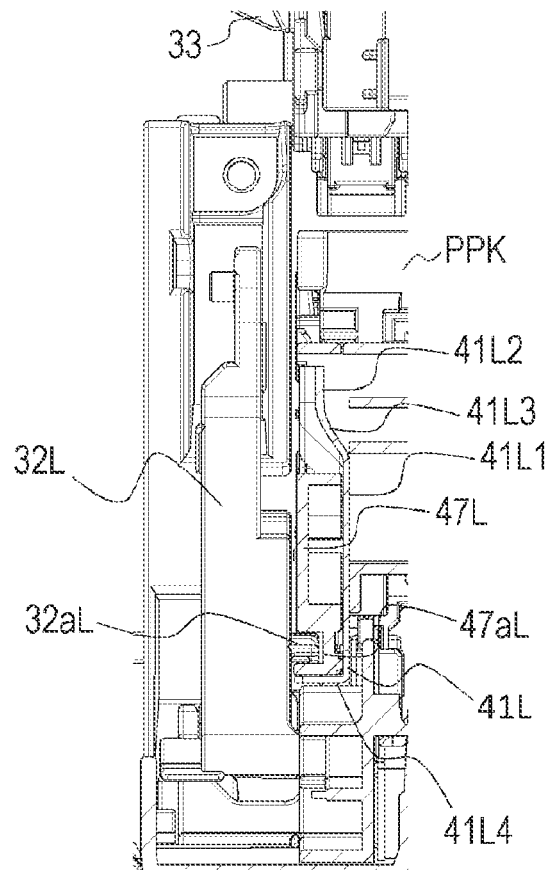

FIG. 18A

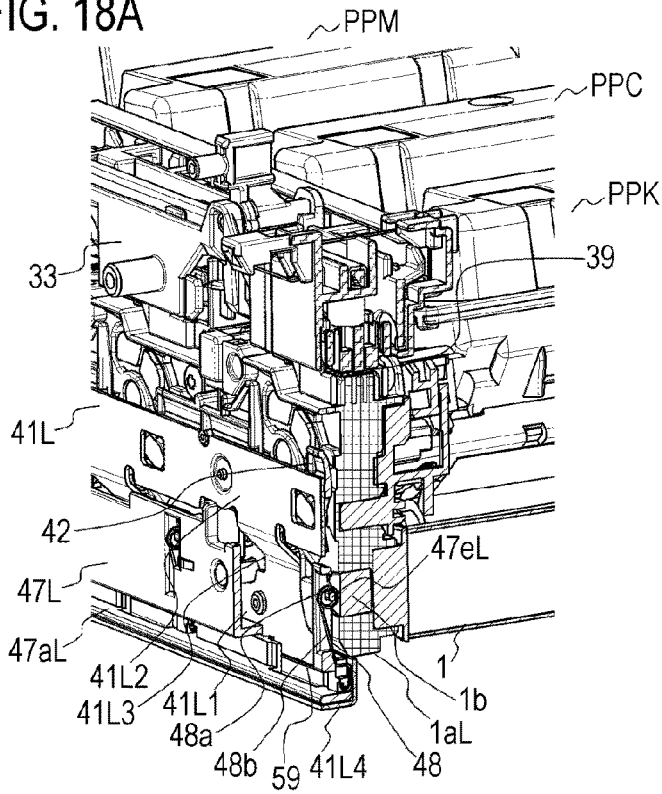

FIG. 18B

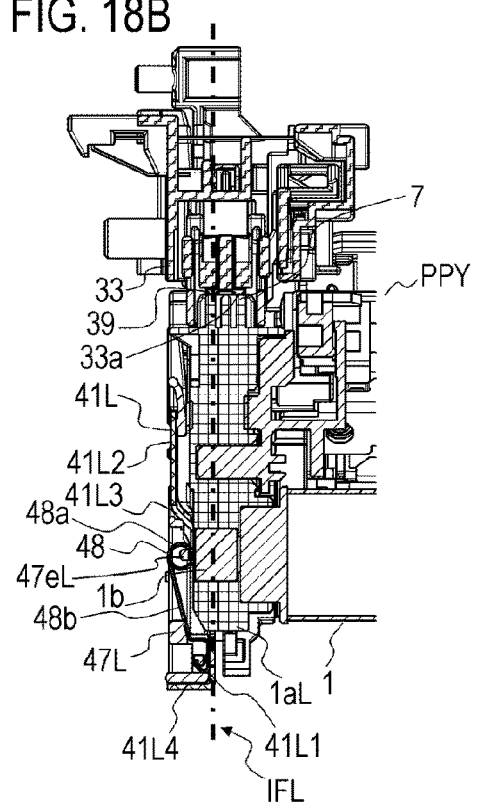

FIG. 18C

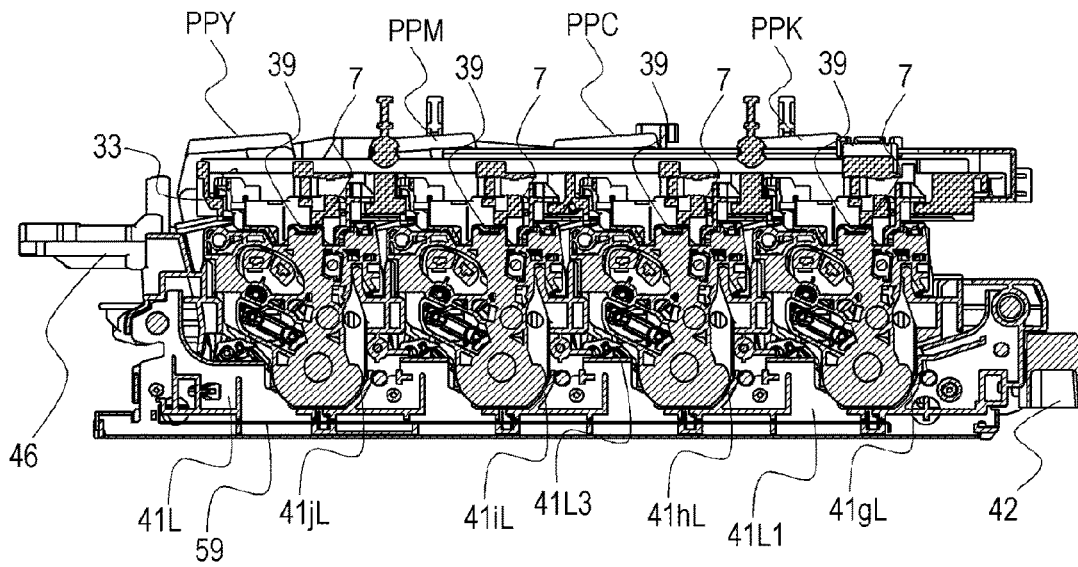

FIG. 19A

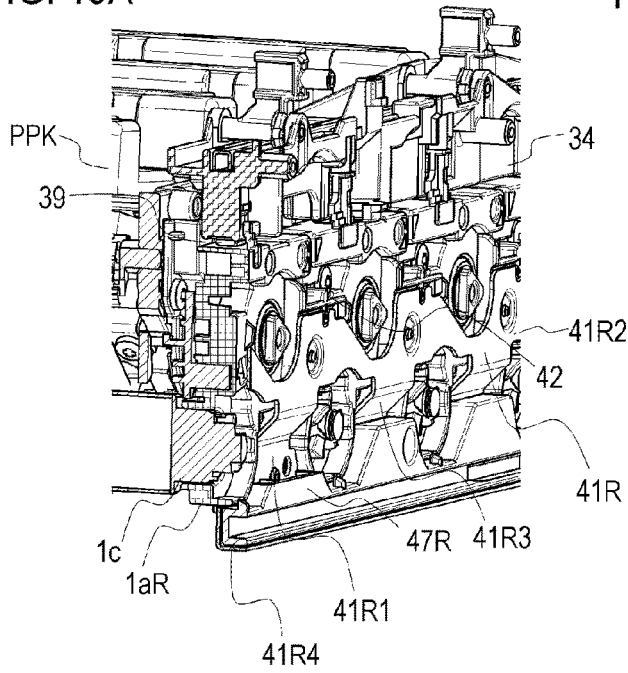

FIG. 19B

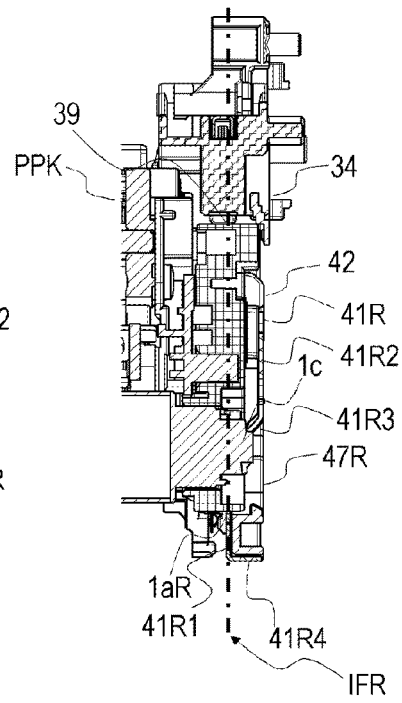

FIG. 19C

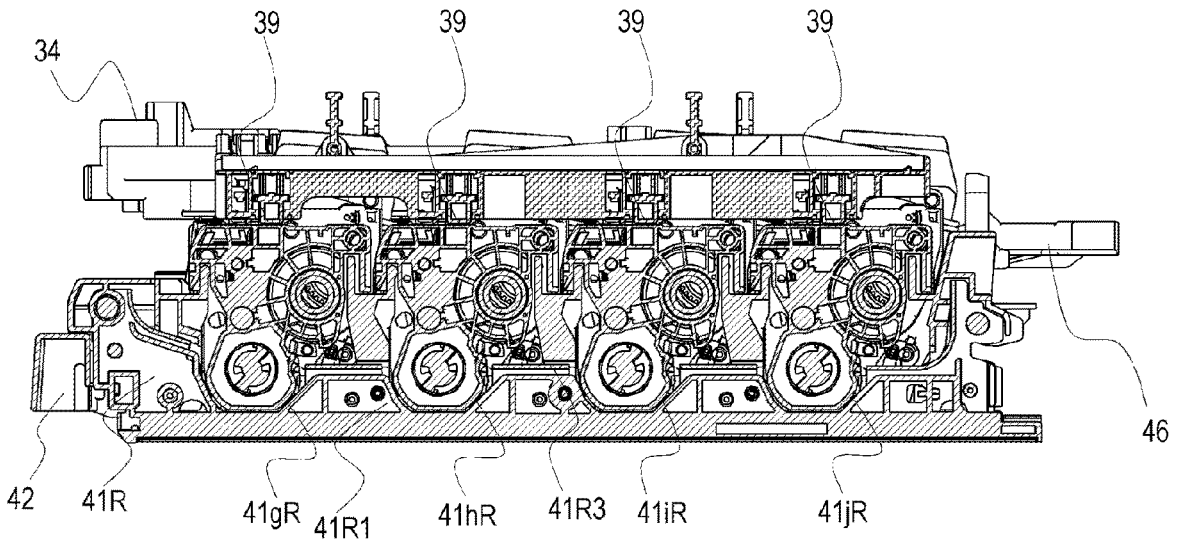

FIG. 20A

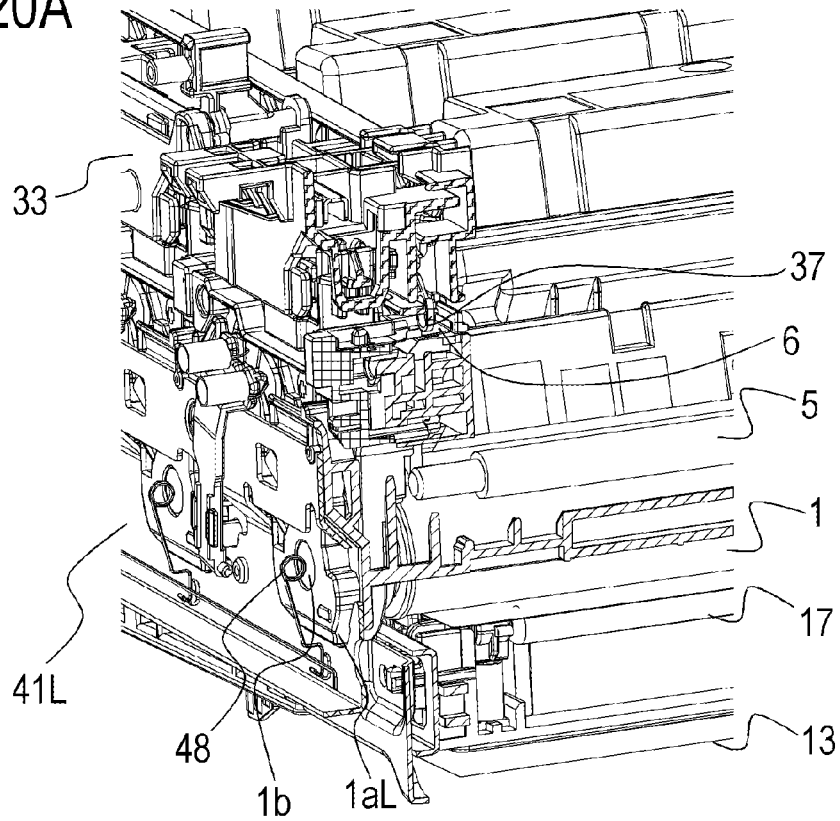
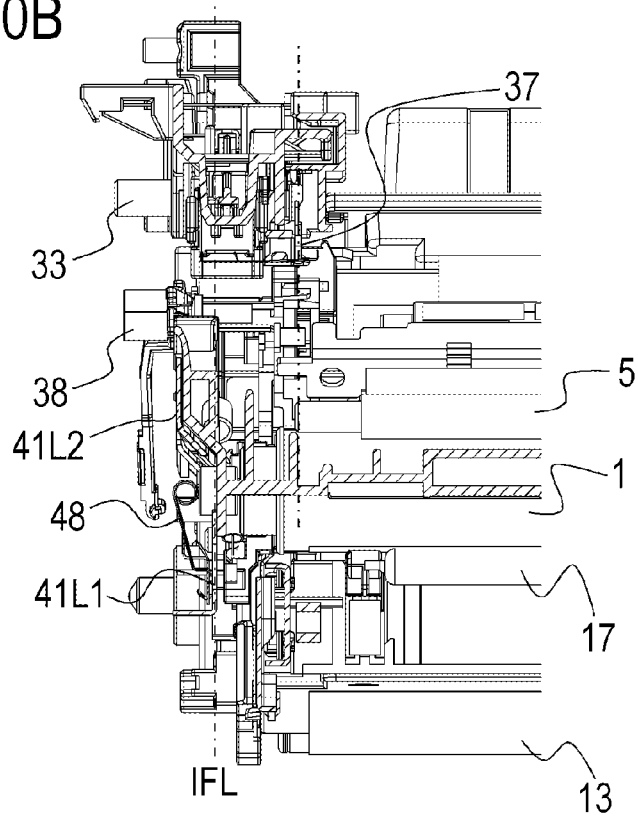

FIG. 20B



**IMAGE FORMING APPARATUS HAVING
IMPROVED MOUNTABILITY OF A
CARTRIDGE WHILE CONSERVING SPACE**

BACKGROUND OF THE INVENTION

Field of the Invention

The present invention relates to an image forming apparatus that forms images on recording material.

Description of the Related Art

There are image forming apparatuses, such as printers, photocopiers, multifunction peripherals, and so forth, in which a cartridge is detachably mounted to a moving member that moves between the interior and the exterior of an apparatus main body. Japanese Patent Application Publication No. 2016-114620 discloses an image forming apparatus in which a cartridge is detachably mounted to a moving member that moves between the interior and the exterior of an apparatus main body. The moving member in Japanese Patent Application Publication No. 2016-114620 is provided with a metal reinforcement member.

SUMMARY OF THE INVENTION

The present invention is a further advancement of the conventional technology. The present invention relates to an image forming apparatus including an apparatus main body, and a tray unit having a side plate formed of metal, to which a cartridge is detachably mounted, in which the tray unit is configured to be movable as to the apparatus main body. It is an object of the present invention to provide technology capable of improving mountability of the cartridge to the apparatus main body and conservation of space of the apparatus configuration.

In order to solve the above-described problem, an image forming apparatus according to the present invention, configured to perform image forming operations using a cartridge, includes:

- an apparatus main body; and
- a tray unit to which the cartridge is detachably mounted, and that is configured to be capable of moving with respect to the apparatus main body, between an internal position situated within the apparatus main body and an external position situated outside of the apparatus main body, the tray unit including:
 - a first side plate configured to support the cartridge, wherein the first side plate is made of metal, and includes a first supporting portion and a first outer side portion, the first supporting portion includes a first positioning portion, and the first positioning portion is configured to come into contact with the cartridge to position the cartridge as to an image forming position at which the image forming operation is performed,
 - a second side plate configured to support the cartridge, wherein the second side plate is made of metal, and includes a second supporting portion and a second outer side portion, the second supporting portion includes a second positioning portion, and the second positioning portion is configured to come into contact with the cartridge to position the cartridge as to the image forming position, and
 - a mounting portion to which the cartridge is mounted in a mounting direction, wherein the mounting portion

is formed between the first side plate and the second side plate, and, in a case of being viewed in the mounting direction, the first supporting portion and the second supporting portion are situated between the first outer side portion and the second outer side portion in the longitudinal direction of the cartridge mounted to the mounting portion,

wherein the apparatus main body includes:

- a first pressing member that is capable of moving between a first pressing position at which the cartridge is pressed, and a first separated position separated from the cartridge, and
- a second pressing member that is capable of moving between a second pressing position at which the cartridge is pressed, and a second separated position separated from the cartridge,

wherein the first pressing member is disposed intersecting with a first imaginary plane that is orthogonal to the longitudinal direction and intersects the first positioning portion,

and wherein the second pressing member is disposed intersecting with a second imaginary plane that is orthogonal to the longitudinal direction and intersects the second positioning portion.

In order to solve the above-described problem, an image forming apparatus according to the present invention, configured to perform image forming operations using a cartridge, includes:

- an apparatus main body; and
 - a tray unit to which the cartridge is detachably mounted, and that is configured to be capable of moving with respect to the apparatus main body, between an internal position situated within the apparatus main body and an external position situated outside of the apparatus main body, the tray unit including:
 - a first side plate configured to support the cartridge, wherein the first side plate is made of metal, and includes a first supporting portion and a first outer side portion, the first supporting portion includes a first positioning portion, and the first positioning portion is configured to come into contact with the cartridge to position the cartridge as to an image forming position at which the image forming operation is performed,
 - a second side plate configured to support the cartridge, wherein the second side plate is made of metal, and includes a second supporting portion and a second outer side portion, the second supporting portion includes a second positioning portion, and the second positioning portion is configured to come into contact with the cartridge to position the cartridge as to the image forming position, and
 - a mounting portion to which the cartridge is mounted in a mounting direction, wherein the mounting portion is formed between the first side plate and the second side plate, and, in a case of being viewed in the mounting direction, the first supporting portion and the second supporting portion are situated between the first outer side portion and the second outer side portion in the longitudinal direction of the cartridge mounted to the mounting portion,
- wherein the tray unit has a tray contact configured to be electrically connected to a cartridge contact of the cartridge, the tray contact having a contact portion that comes into contact with the cartridge contact,

3

and wherein the contact portion is situated between the second supporting portion and the second outer side portion in the longitudinal direction.

In order to solve the above-described problem, an image forming apparatus according to the present invention, configured to perform image forming operations using a cartridge, includes:

- an apparatus main body; and
- a tray unit to which the cartridge is detachably mounted, and that is configured to be capable of moving with respect to the apparatus main body, between an internal position situated within the apparatus main body and an external position situated outside of the apparatus main body, the tray unit including:
 - a first side plate configured to support the cartridge, wherein the first side plate is made of metal, and includes a first supporting portion and a first outer side portion, the first supporting portion includes a first positioning portion, and the first positioning portion is configured to come into contact with the cartridge to position the cartridge as to an image forming position at which the image forming operation is performed,
 - a second side plate configured to support the cartridge, wherein the second side plate is made of metal, and includes a second supporting portion and a second outer side portion, the second supporting portion includes a second positioning portion, and the second positioning portion is configured to come into contact with the cartridge to position the cartridge as to the image forming position, and
 - a mounting portion to which the cartridge is mounted in a mounting direction, wherein the mounting portion is formed between the first side plate and the second side plate, and, in a case of being viewed in the mounting direction, the first supporting portion and the second supporting portion are situated between the first outer side portion and the second outer side portion in the longitudinal direction of the cartridge mounted to the mounting portion,

wherein the tray unit has a first guided groove and a second guided groove that are guided by the apparatus main body in case of moving from the external position to the internal position,

and wherein, with respect to the longitudinal direction, at least part of the first guided groove is situated between the first supporting portion and the first outer side portion, and at least part of the second guided groove is situated between the second supporting portion and the second outer side portion.

According to the present invention, mountability of the cartridge to the apparatus main body and conservation of space of the apparatus configuration can be improved.

Further features of the present invention will become apparent from the following description of exemplary embodiments with reference to the attached drawings.

BRIEF DESCRIPTION OF THE DRAWINGS

FIG. 1 is an overall perspective diagram illustrating a printer according to a first embodiment of the present disclosure;

FIG. 2 is an overall schematic diagram illustrating an internal configuration of the printer;

FIGS. 3A and 3B are a frontal perspective view and a rear perspective view illustrating a process cartridge;

4

FIGS. 4A and 4B are a frontal perspective view and a rear perspective view illustrating a cartridge tray;

FIGS. 5A and 5B are a frontal perspective view and a rear perspective view illustrating a cartridge tray in a state in which process cartridges are mounted;

FIGS. 6A and 6B are side views illustrating a driving side of the cartridge tray;

FIGS. 7A and 7B are side views illustrating a non-driving side of the cartridge tray;

FIG. 8 is a top view of the cartridge tray;

FIG. 9 is a perspective view illustrating a frame structure of a printer main body;

FIG. 10 is a bottom perspective view illustrating a positioning shaft of the cartridge tray;

FIG. 11A is a cross-sectional view illustrating a state in which a positioning shaft at an apparatus main body side is engaged with a positioning groove;

FIG. 11B is a cross-sectional view illustrating the positioning shaft and the positioning groove in a state in which the cartridge tray is slightly drawn out from the mounted state;

FIG. 11C is a cross-sectional view illustrating the positioning shaft and the positioning groove in a state in which the cartridge tray is further drawn out from the state in FIG. 11B;

FIG. 11D is a cross-sectional view illustrating a state in which the positioning shaft of the cartridge tray side is engaged with the positioning groove;

FIG. 11E is a cross-sectional view illustrating the positioning shaft and the positioning groove in a state in which the cartridge tray is slightly drawn out from the mounted state;

FIG. 11F is a cross-sectional view illustrating the positioning shaft and the positioning groove in a state in which the cartridge tray is further drawn out from the state in FIG. 11E;

FIG. 12 is a frontal view illustrating a rib provided to the cartridge tray;

FIG. 13 is a view along arrows A in FIG. 12;

FIG. 14A is a frontal perspective view of the process cartridges and the cartridge tray in a state in which a front door is closed;

FIG. 14B is a frontal perspective view of the process cartridges and the cartridge tray in a state in which the front door is open;

FIG. 15A is a rear perspective view of the process cartridges and the cartridge tray in a state in which the front door is closed;

FIG. 15B is a rear perspective view of the process cartridges and the cartridge tray in a state in which the front door is open;

FIG. 16A is a side view of the process cartridges and the cartridge tray in a state in which the front door is closed;

FIG. 16B is a side view of the process cartridges and the cartridge tray in a state in which the front door is open;

FIG. 16C is a side view of the process cartridges and the cartridge tray in a state in which the front door is open;

FIGS. 17A and 17B are diagrams illustrating a state in which the cartridge tray is drawn out;

FIGS. 18A through 18C are diagrams illustrating a pressing state at a left side of the process cartridges and a contact state of contacts;

FIGS. 19A through 19C are diagrams illustrating a pressing state at a right side of the process cartridges; and

FIGS. 20A and 20B are diagrams illustrating a positional relation between a contact portion for power supply to a charging roller, and a photosensitive drum and so forth.

DESCRIPTION OF THE EMBODIMENTS

Hereinafter, a description will be given, with reference to the drawings, of embodiments (examples) of the present invention. However, the sizes, materials, shapes, their relative arrangements, or the like of constituents described in the embodiments may be appropriately changed according to the configurations, various conditions, or the like of apparatuses to which the invention is applied. Therefore, the sizes, materials, shapes, their relative arrangements, or the like of the constituents described in the embodiments do not intend to limit the scope of the invention to the following embodiments. Each of the embodiments of the present invention described below can be implemented solely or as a combination of a plurality of the embodiments or features thereof where necessary or where the combination of elements or features from individual embodiments in a single embodiment is beneficial.

First Embodiment

Overall Configuration

First, a printer **100** serving as an image forming apparatus according to a first embodiment is a full-color laser beam printer according to an electrophotographic system. The printer **100** has an apparatus main body **100A** and a front door **31** supported so as to be capable of opening and closing as to the apparatus main body **100A**, as illustrated in FIG. 1. Note that directions are defined as follows in description of the printer **100**. That is to say, the side of the printer **100** on which the front door **31** is provided is a front side (or front face side), and the opposite side therefrom is a back side (or rear face side), and the direction from the back side toward the front side and the direction from the front side toward the back side is a front-back direction.

Also, a left side (or non-driving side) and a right side (or driving side), and an upper side and a lower side are defined with a state of viewing the printer **100** from the front side as a reference. The direction from the right side toward the left side and the direction from the left side toward the right side is a right-left direction, and the direction from the lower side toward the upper side and the direction from the upper side toward the lower side is an up-down direction.

The printer **100** has an image forming unit **10** that forms images on sheets **S**, a sheet feeding portion **18**, a fixing device **23**, a discharge roller pair **24**, and a control portion **200**, as illustrated in FIG. 2. The printer **100** can form full-color images or monochrome images on sheet-like recording media (hereinafter, referred to as "sheet **S**"), on the basis of electrical image signals input to the control portion **200**, output from an external host device **400** via an interface portion **300**. Examples of the external host device **400** include a personal computer, an image reader, a facsimile apparatus, and so forth.

The control portion **200** is a control unit for controlling an electrophotographic image forming process of the printer **100**, and exchanges various types of electrical information with the external host device **400**. The control portion **200** also governs processing of electrical information input from various types of process devices and sensor, processing of command signals to various types of process devices, predetermined initial sequence control, sequence control of predetermined image forming processes, and so forth.

The sheet feeding portion **18** is provided at a lower portion of the printer **100**, and includes a cassette **19** that accommodates the sheets **S**, a sheet plate **21** that supports the sheets **S** so as to be capable of being raised and lowered, a

pick-up roller **20a**, and a separating roller pair **20b**. The cassette **19** is configured to be capable of being drawn out and mounted from the front side of the apparatus main body **100A**. The sheets **S** loaded on the sheet plate **21** are fed by the pick-up roller **20a**, and separated into individual sheets by the separating roller pair **20b**. Note that a torque limiter system or a retard roller system may be applied to the separating roller pair **20b**, and a separating pad may be applied instead of one roller of the separating roller pair **20b**.

The fixing device **23** has a fixing film **23a** that is heated by a heater, and a pressure roller **23b** that presses against the fixing film **23a**, forming a fixing nip **Q** by the fixing film **23a** and the pressure roller **23b**. The discharge roller pair **24** has a discharge driving roller **24a**, and a discharge driven roller **24b** that rotates following driving of the discharge driving roller **24a**.

The image forming unit **10** has a cartridge tray **40**, four process cartridges (cartridges) **PPY**, **PPM**, **PPC**, and **PPK**, a scanner unit **11**, a transfer unit **12**, and a cleaning unit **26**. The transfer unit **12** has a driving roller **14**, an auxiliary roller **15**, a tension roller **16**, and an intermediate transfer belt **13**. The intermediate transfer belt **13** is stretched over the driving roller **14**, the auxiliary roller **15**, and the tension roller **16**, is configured of a dielectric material, and has flexibility. The printer **100** is configured to perform image forming operations using the process cartridges **PPY**, **PPM**, **PPC**, and **PPK** that are detachably mountable to the apparatus main body **100A**.

Primary transfer rollers **17Y**, **17M**, **17C**, and **17K** that face the respective photosensitive drums of the process cartridges **PPY**, **PPM**, **PPC**, and **PPK** are provided on the inner side of the intermediate transfer belt **13**. A secondary transfer roller **27** is provided on the opposite side of the driving roller **14** across the intermediate transfer belt **13**. The intermediate transfer belt **13** and the secondary transfer roller **27** together form a secondary transfer nip **T2**.

The four process cartridges **PPY**, **PPM**, **PPC**, and **PPK** form toner images of the four colors of yellow (**Y**), magenta (**M**), cyan (**C**), and black (**K**), respectively. Note that the four process cartridges **PPY**, **PPM**, **PPC**, and **PPK** each have the same configuration, other than the color of images formed thereby (the color of toner accommodated) being different. Accordingly, the configuration and the image forming process will be described regarding one of the four process cartridges **PPY**, **PPM**, **PPC**, and **PPK**, and description of the others will be omitted. Also, if there is no need to distinguish among the process cartridges **PPY**, **PPM**, **PPC**, and **PPK**, the process cartridges **PPY**, **PPM**, **PPC**, and **PPK** may be referred to simply as "process cartridges **PP**".

The process cartridge **PPY** has a drum unit **OP** and a developing unit **DP** integrated into a unit, as illustrated in FIGS. 2 through 3B. The drum unit **OP** has a photosensitive drum **1** serving as an image bearing member, and the developing unit **DP** has a developing roller **3** that develops a latent image formed on the photosensitive drum **1** as a toner image, and a storage portion **3b** that stores a developer. A drum coupling (driving transmission member, first driving transmission member) **1c** and a developing coupling (driving transmission member, second driving transmission member) **3c** are each provided on the driving side (right side) in the longitudinal direction of the photosensitive drum **1** and the developing roller **3**. Driving force from an unshown driving force source of the apparatus main body **100A** is transmitted to the drum coupling **1c** and the developing coupling **3c**, and the photosensitive drum **1** and the developing roller **3** rotate.

Also, a cartridge developing contact **2** is provided on the non-driving side (left side) in the longitudinal direction of the developing roller **3**. Developing bias is applied to the cartridge developing contact **2**, in a state of being in contact with a later-described main body developing contact **38** (see FIG. **20B**) provided to the apparatus main body **100A**. A grounding member (cartridge contact, cartridge electrode) **1b** for connecting the photosensitive drum **1** to ground potential is provided at the non-driving side in the longitudinal direction of the photosensitive drum **1**.

A drum bearing (driving side support member, first end portion supporting member) **1aR** is provided to a driving side end portion (first end portion) of the process cartridge PPY in the longitudinal direction of the process cartridge PPY, as illustrated in FIGS. **3A** and **3B**. A drum bearing (non-driving side support member, second end portion supporting member) **1aL** is provided to a non-driving side end portion (second end portion) of the process cartridge PPY at the opposite side from the driving side end portion. The drum bearing **1aR** and the drum bearing **1aL** support the photosensitive drum **1**.

Note that the longitudinal direction of the process cartridge PPY is the same as the rotation axis direction (longitudinal direction) of the photosensitive drum **1** and the rotation axis direction (longitudinal direction) of the developing roller **3**. When describing the apparatus main body **100A** and the cartridge tray **40** in the following description, the term "longitudinal direction of the process cartridge PPY" means the longitudinal direction of the process cartridge PPY in a state mounted to a later-described mounting portion **40a**. In this case, the longitudinal direction of the process cartridge PPY is the direction of movement of the cartridge tray **40**, and is the direction orthogonal to the direction of mounting the process cartridges PP in the present embodiment.

The process cartridges PPY, PPM, PPC, and PPK, which are the plurality of cartridges, are detachably mounted to the cartridge tray (tray unit, moving member, moving unit) **40**. The cartridge tray **40** is configured to be movable with respect to the apparatus main body **100A**, between an internal position situated within the apparatus main body **100A** and an external position situated outside of the apparatus main body **100A**, in a state of supporting the process cartridges PPY, PPM, PPC, and PPK, which will be described later. In the present embodiment, when the cartridge tray **40** is situated at the internal position, the process cartridges PPY, PPM, PPC, and PPK are situated at image forming positions, and perform image forming operations. When the cartridge tray **40** is situated at the external position, the process cartridges PPY, PPM, PPC, and PPK are situated at mounting/detaching positions, and can be mounted to or detached from the cartridge tray **40**.

The printer **100** is provided with the front door (opening/closing member) **31** attached to the apparatus main body **100A**. The front door **31** is capable of moving between a closed position of covering the cartridge tray **40** at the internal position and an open position of exposing the cartridge tray **40** at the internal position. By the user opening the front door **31**, the cartridge tray **40** is exposed, and the user can access the cartridge tray **40**. The user can then bring the process cartridges PPY, PPM, PPC, and PPK to be situated at the mounting/detaching position by drawing the cartridge tray **40** out to the front side, and can replace the process cartridges PPY, PPM, PPC, and PPK.

Image Forming Operations

Next image forming operations of the printer **100** configured in this way will be described. Upon the control portion

200 of the printer **100** receiving job signals from the interface portion **300**, an unshown developing separating mechanism provided to the apparatus main body **100A** moves in the front-back direction. The developing separating mechanism brings the developing roller **3** into contact with the photosensitive drum **1**.

Note that in a job of forming a monochrome image, only the photosensitive drum of the process cartridge PPK comes into contact with the developing roller, while in a job of forming a full-color image, the photosensitive drums of the process cartridges PPY, PPM, PPC, and PPK come into contact with the respective developing rollers. The photosensitive drums, the developing rollers, and the intermediate transfer belt **13** are then driven by the unshown driving force source.

A scanner unit **11** casts a laser beam corresponding to image signals onto the photosensitive drum **1** of the process cartridge PPY. The surface of the photosensitive drum **1** at this time is uniformly charged to a predetermined polarity and potential in advance by a charging member (charging roller) **5**, and an electrostatic latent image is formed on the surface by the laser being cast from the scanner unit **11**. The electrostatic latent image formed on the photosensitive drum **1** is developed by the developing roller **3**, thereby forming a yellow (Y) toner image on the photosensitive drum **1**.

Note that the cartridge tray **40** is provided with light guides **57** (see FIG. **5B**) as pre-exposing unit. The light guides **57** are each formed of transparent acrylic or the like, for example. Light from an unshown light source is emitted prior to the charging roller **5** charging the surface of the photosensitive drum **1**, and this light is cast on the surface of the photosensitive drum **1** in a state of being uniformly dispersed in the longitudinal direction by the light guide **57**. Accordingly, the potential at the surface of the photosensitive drum **1** is stabilized, and good toner images can be formed.

In the same way, a laser beam is cast from the scanner unit **11** onto the photosensitive drum in each of the process cartridges PPM, PPC, and PPK, and magenta (M), cyan (C), and black (K) toner images are formed on the respective photosensitive drums. The toner images of the respective colors formed on the respective photosensitive drums are transferred into the intermediate transfer belt **13** by primary transfer bias applied to the primary transfer rollers **17Y**, **17M**, **17C**, and **17K**. The full-color toner image transferred onto the intermediate transfer belt **13** is conveyed to the secondary transfer nip **T2** by the intermediate transfer belt **13** rotated by the driving roller **14**. Note that the image forming processes of each of the colors are performed at timings for overlaying onto the toner image transferred upstream onto the intermediate transfer belt **13** by primary transfer.

In parallel with this image forming process, a sheet **S** sent out by the sheet feeding portion **18** is subjected to skew correction by a registration roller pair **22**. The registration roller pair **22** further conveys the sheet **S** toward the secondary transfer roller **27**, in accordance with the toner image being conveyed by the intermediate transfer belt **13**. The full-color toner image on the intermediate transfer belt **13** is transferred onto the sheet **S** at the secondary transfer nip **T2**, by the secondary transfer bias applied to the secondary transfer roller **27**. Also, after the transfer of the toner image, the toner remaining on the surface of the intermediate transfer belt **13** is removed by the cleaning unit **26**, and is recovered to a waste toner recovery container that is omitted from illustration.

The sheet S onto which the toner image is transferred is subjected to predetermined heat and pressure at the fixing nip Q of the fixing device 23. This causes the toner to melt, and subsequently be hardened, thereby fixing the image onto the sheet S. The sheet S that has passed through the fixing device 23 is discharged onto a discharge tray 25 by the discharge roller pair 24.

Cartridge Tray

Next, the configuration of the cartridge tray 40 will be described. The cartridge tray 40 has tray side plates 41L and 41R that are disposed with a gap therebetween in the right-left direction, linking members 42, 43, 44, 45, and 46 that link the tray side plates 41L and 41R to each other, and guide members 47L and 47R, as illustrated in FIGS. 4A and 4B. Note that in the following description, members that are provided as pair of right and left members are distinguished regarding right and left by appending "R" or "L" after the signs.

The process cartridges PPY, PPM, PPC, and PPK are supported by the tray side plates 41L and 41R. The mounting portions 40a to which the process cartridges PPY, PPM, PPC, and PPK are mounted are formed between the tray side plate (driving-side side plate, first side plate) 41R and the tray side plate (non-driving-side side plate, second side plate) 41L. The process cartridge PPY is mounted to a mounting portion 40aY, the process cartridge PPM is mounted to a mounting portion 40aM, the process cartridge PPC is mounted to a mounting portion 40aC, and the process cartridge PPK is mounted to a mounting portion 40aK. The process cartridges PPY, PPM, PPC, and PPK are mounted to the mounting portions 40aY, 40aM, 40aC, and 40aK, following the mounting direction (the direction of arrow In).

The linking members 42, 43, 44, 45, and 46 are made of a resin material, and are arrayed in order from the front side toward the rear side. The above-described light guide 57 is provided to each of the linking members 42, 43, 44, and 45. The tray side plates 41L and 41R are made of a metal material. The guide member (driving side cover member, first cover member) 47R is supported by the tray side plate 41R, and the guide member (non-driving side cover member, second cover member) 47L is supported by the tray side plate 41L. The guide member 47R is provided with a guide groove (first guided groove) 47aR, and the guide member 47L is provided with a guide groove (second guided groove) 47aL. The guide grooves 47aL and 47aR extend following the direction in which the plurality of cartridges are arrayed, and guide the cartridge tray 40 in the direction of being drawn out from, and the direction of being inserted into, the apparatus main body 100A. The guide grooves 47aL and 47aR also engage unshown stoppers provided to the apparatus main body 100A, thereby restricting the cartridge tray 40 from being drawn out past a predetermined position.

The linking member 42 has receiving portions 42b and a gripping portion 42d. The user can draw the cartridge tray 40 out from the apparatus main body 100A by gripping the gripping portion 42d and pulling. When the printer 100 is subjected to shock from the frontal direction in a state where the front door 31 is closed, the receiving portions 42b suppress damage of internal parts of the printer 100 caused by striking the front door 31. In the same way, the linking member 46 has receiving portions 46a. When the printer 100 is subjected to shock from the rear direction, the receiving portions 46a suppress damage of internal parts of the printer 100 caused by striking a fixing stay 35 (see FIG. 9).

The tray side plates 41L and 41R have shapes in which the upper portions are drawn outwards as compared to the lower portions, with the distance between the tray side plates 41L

and 41R in the right-left direction being greater at the upper portion and smaller at the lower portion. Thus, the right-left width of the cartridge tray 40 can be reduced without impeding the ease of insertion/extraction of the process cartridges PPY, PPM, PPC, and PPK, thereby contributing to reduction in size of the printer 100.

Further, the lower sides of the tray side plates 41L and 41R are bent into a shape of the letter L, thereby ensuring strength. Although the tray side plates 41L and 41R and the linking members 42, 43, 44, 45, and 46 are each fastened by screws, this is not restrictive, and thermal caulking or the like may be used. Also, an arrangement may be made in which the linking members 42 and 46 alone are fastened to the tray side plates 41L and 41R, and the linking members 43, 44, and 45 are not fastened to the tray side plates 41L and 41R.

The tray side plate 41R is provided with cartridge engaging portions (first positioning portion) 41gR, 41hR, 41iR, and 41jR, the cartridge engaging portions 41gR, 41hR, 41iR, and 41jR each being formed having a substantially V-shaped form, as illustrated in FIGS. 4A through 5B. Specifically, the cartridge engaging portions 41gR, 41hR, 41iR, and 41jR are formed so that front-side inclined faces thereof are at a 65° angle as to the direction of drawing out, and rear-side inclined faces thereof are at a 45° angle.

The tray side plate 41L is provided with cartridge engaging portions (second positioning portion) 41gL, 41hL, 41iL, and 41jL, the cartridge engaging portions 41gL, 41hL, 41iL, and 41jL being formed having substantially V-shaped forms, as illustrated in FIG. 4A. Specifically, the cartridge engaging portions 41gL, 41hL, 41iL, and 41jL are formed so that front-side inclined faces thereof are at a 65° angle as to the direction of drawing out, and rear-side inclined faces thereof are at a 45° angle.

The process cartridges PPY, PPM, PPC, and PPK are positioned by the cartridge tray 40 at image forming positions to perform image forming operations. While image forming operations are performed, the drum bearing 1aR (see FIG. 3A) of the process cartridge PPY comes into contact with the cartridge engaging portion 41gR, and the drum bearing 1aL (see FIG. 3B) of the process cartridge PPY comes into contact with the cartridge engaging portion 41gL. In the same way, the drum bearings 1aR of the process cartridges PPM, PPC, and PPK come into contact with the cartridge engaging portions 41hR, 41iR, and 41jR. Also, the drum bearings 1aL of the process cartridges PPM, PPC, and PPK come into contact with the cartridge engaging portions 41hL, 41iL, and 41jL. That is to say, the cartridge engaging portion 41gR and the cartridge engaging portion 41gL come into contact with and support the drum bearing 1aR and the drum bearing 1aL of the process cartridge PPY, so that the process cartridge PPY is positioned at the image forming position. In the same way, the cartridge engaging portions 41hR, 41iR, and 41jR and the cartridge engaging portions 41hL, 41iL, and 41jL come into contact with and support the drum bearings 1aR and the drum bearings 1aL of the process cartridges PPM, PPC, and PPK.

The process cartridges PPY, PPM, PPC, and PPK are positioned as to the cartridge tray 40, either under their own weight, or be being pressed downward by pressing units 33 and 34 (first pressing member 34, second pressing member 33) (FIGS. 14A through 20B). The pressing units 33 and 34 position the process cartridges, and the cartridge tray 40 that is integral with the process cartridges, as to the apparatus main body 100A, by pressing the process cartridges in the downward direction at the time of forming images. The pressing units 33 and 34 are assembled to the apparatus main

body 100A so as to be capable of moving between a pressing position of pressing the process cartridges and a separated position of being separated from the process cartridges, in interrelation with opening and closing actions of the front door 31 of the printer 100, which will be described later in detail.

Also, boss portions 42aL, 43aL, 44aL, and 45aL are respectively formed to the left end portions of the linking members 42, 43, 44, and 45, and boss portions 42aR, 43aR, 44aR, and 45aR are respectively formed to the right end portions thereof. Note that groove portions 1dR and 1dL are formed on the right and left end portions of the process cartridges for each of the colors, as illustrated in FIGS. 3A and 3B. The groove portions 1dR and 1dL of the process cartridges PPY, PPM, PPC, and PPK then engage the boss portions 42aL, 43aL, 44aL, and 45aL at the left end side, and engage the boss portions 42aR, 43aR, 44aR, and 45aR at the right end side. Thus, the process cartridges PPY, PPM, PPC, and PPK are suppressed from rotating as to the cartridge tray 40.

Thus, the process cartridges PPY, PPM, PPC, and PPK are mounted to the cartridge tray 40, and each process cartridge is grounded by a wire member (drum ground) 48 provided to the guide member 47L.

Details of Cartridge Tray

Details of the cartridge tray 40 will be described with reference to FIGS. 6A through 8. FIGS. 6A and 6B are side views illustrating the driving side of the cartridge tray 40. FIGS. 6A and 6B are diagrams viewing the cartridge tray 40 along the longitudinal direction of the process cartridge PPY, and the guide member 47R is not illustrated in FIG. 6B. FIGS. 7A and 7B are side views illustrating the non-driving side of the cartridge tray 40. FIGS. 7A and 7B are diagrams viewing the cartridge tray 40 along the longitudinal direction of the process cartridge PPY, and the guide member 47L is not illustrated in FIG. 7B. FIG. 8 is a top view of the cartridge tray 40. FIG. 8 is a diagram viewing the cartridge tray 40 along the mounting direction in of the process cartridges PPY, PPM, PPC, and PPK.

The tray side plate 41R is provided with a first supporting portion 41R1 that has the cartridge engaging portions 41gR, 41hR, 41iR, and 41jR, a first outer side portion 41R2, and a first connecting portion 41R3 that connects the first supporting portion 41R1 and the first outer side portion 41R2, as illustrated in FIG. 6B. The tray side plate 41R is made of metal. In the present embodiment, the tray side plate 41R is one metal plate, and is integrally provided with the first supporting portion 41R1, the first outer side portion 41R2, and the first connecting portion 41R3. The first supporting portion 41R1 and the first outer side portion 41R2 extend following the moving direction in which the cartridge tray 40 moves as to the apparatus main body 100A.

The tray side plate 41R is formed by drawing on a metal plate. As a result, the first connecting portion 41R3 has a portion situated between the first supporting portion 41R1 and the first outer side portion 41R2 in the horizontal direction, and a portion situated between the first supporting portion 41R1 and the first outer side portion 41R2 in the vertical direction, as viewed in the longitudinal direction of the process cartridge PPY. Further, the tray side plate 41R is provided with first openings 41R5. The cartridge engaging portions 41gR, 41hR, 41iR, and 41jR are formed in the first openings 41R5. The upper end of the first openings 41R5 is situated higher than the lower end of the first outer side portion 41R2, and the lower end of the first openings 41R5 is situated lower than the upper end of the first supporting portion 41R1 and the first connecting portion 41R3, with

respect to the vertical direction. The process cartridges PPY, PPM, PPC, and PPK are exposed to the outside of the mounting portions 40a through the first openings 41R5. More specifically, the drum couplings 1c of the process cartridges PPY, PPM, PPC, and PPK are externally exposed from the cartridge tray 40 through the first openings 41R5.

As illustrated in FIG. 6A, the cartridge tray 40 has the guide member (first cover member) 47R that is attached to the tray side plate 41R on the outer side of the mounting portions 40a. The guide member 47R covers the first supporting portion 41R1. More specifically, the guide member 47R covers the first supporting portion 41R1 such that the cartridge engaging portions 41gR, 41hR, 41iR, and 41jR are exposed when viewed in the longitudinal direction of the process cartridge PPY.

Also, as described above, the guide member 47R is provided with the guide groove (first guided groove) 47aR. The guide groove 47aR is situated on the downstream side of the cartridge engaging portions 41gR, 41hR, 41iR, and 41jR in the mounting direction in of the process cartridges PPY, PPM, PPC, and PPK. The guide groove 47aR extends in the direction in which the process cartridges PPY, PPM, PPC, and PPK are arrayed. Accordingly, the cartridge tray 40 is capable of moving as to the apparatus main body 100A in the direction in which the process cartridges PPY, PPM, PPC, and PPK are arrayed.

The tray side plate 41L is provided with a second supporting portion 41L1 that has the cartridge engaging portions 41gL, 41hL, 41iL, and 41jL, a second outer side portion 41L2, and a second connecting portion 41L3 that connects the second supporting portion 41L1 and the second outer side portion 41L2, as illustrated in FIG. 7B. The tray side plate 41L is made of metal. In the present embodiment, the tray side plate 41L is one metal plate, and is integrally provided with the second supporting portion 41L1, the second outer side portion 41L2, and the second connecting portion 41L3. The second supporting portion 41L1 and the second outer side portion 41L2 extend along the moving direction in which the cartridge tray 40 moves as to the apparatus main body 100A.

The tray side plate 41L is formed by drawing on a metal plate. As a result, the second connecting portion 41L3 has a portion situated between the second supporting portion 41L1 and the second outer side portion 41L2 in the horizontal direction, and a portion situated between the second supporting portion 41L1 and the second outer side portion 41L2 in the vertical direction, as viewed in the longitudinal direction of the process cartridge PPY. Further, the tray side plate 41L is provided with second openings (contact openings) 41L5. The cartridge engaging portions 41gL, 41hL, 41iL, and 41jL are formed in the second openings 41L5. The upper end of the second openings 41L5 is situated higher than the lower end of the second outer side portion 41L2, and the lower end of the second openings 41L5 is situated lower than the upper end of the second supporting portion 41L1 and the second connecting portion 41L3, with respect to the vertical direction. The process cartridges PPY, PPM, PPC, and PPK are exposed to the outside of the mounting portions 40a through the second openings 41L5. More specifically, the grounding members 1b of the process cartridges PPY, PPM, PPC, and PPK are externally exposed from the mounting portions 40a through the second openings 41L5.

As illustrated in FIG. 7A, the cartridge tray 40 has the guide member (second cover member) 47L that is attached to the tray side plate 41L on the outer side of the mounting portions 40a. The guide member 47L covers the second

supporting portion **41L1**. More specifically, the guide member **47L** covers the second supporting portion **41L1** such that at least part of the second openings **41L5** is covered as viewed in the longitudinal direction of the process cartridge PPY. The guide member **47L** is also provided with the wire members **48**. The wire members **48** are disposed at positions that overlap the second openings **41L5** as viewed in the longitudinal direction of the process cartridge PPY.

Also, the guide member **47L** is provided with the guide groove (second guided groove) **47aL**, as described above. The guide groove **47aL** is situated on the downstream side of the cartridge engaging portions **41gL**, **41hL**, **41iL**, and **41jL** in the mounting direction In of the process cartridges PPY, PPM, PPC, and PPK. The guide groove **47aL** extends in the direction in which the process cartridges PPY, PPM, PPC, and PPK are arrayed. Accordingly, the cartridge tray **40** is capable of moving as to the apparatus main body **100A** in the direction in which the process cartridges PPY, PPM, PPC, and PPK are arrayed.

As illustrated in FIG. 8, when viewed in the mounting direction In, the first supporting portions **41R1** and the second supporting portions **41L1** are situated between the first outer side portion **41R2** and the second outer side portion **41L2** in the longitudinal direction (arrow LD) of the process cartridges PP mounted to the mounting portion **40a**. Also, when viewed in the mounting direction In, the cartridge engaging portions **41gR**, **41hR**, **41iR**, and **41jR** are exposed to the upstream side (near side in the plane of the figure) in the mounting direction In via the first openings **41R5**. In the same way, the cartridge engaging portions **41gL**, **41hL**, **41iL**, and **41jL** are exposed to the upstream side (near side in the plane of the figure) in the mounting direction In via the second openings **41L5**.

Positioning Configuration of Cartridge Tray

Next, a positioning configuration of the cartridge tray **40** will be described. The apparatus main body **100A** (see FIG. 1) has a main body frame **30** having a pair of left and right main body side plates **36L** and **36R**, the fixing stay **35** that links the main body side plates **36L** and **36R** and also compartmentalizes a process region and a fixing region, as illustrated in FIG. 9. The process region is a region where the process cartridges PPY, PPM, PPC, and PPK are accommodated, and the fixing region is a region where the fixing device **23** is accommodated. The main body side plates **36L** and **36R** and the fixing stay **35** are made of a metal material.

The main body side plates **36L** and **36R** have shaft supporting portions **50aL** and **50aR**, respectively, at the deep side of the apparatus, with a positioning shaft **50** being supported by the shaft supporting portions **50aL** and **50aR**. Note that the positioning shaft **50** is immovably fixed to the shaft supporting portions **50aL** and **50aR**, but may be rotatably supported as long as it is not capable of moving in the front-back direction and the up-down direction.

The main body side plates **36L** and **36R** also have positioning grooves **36aL** and **36aR** respectively, at the apparatus front side thereof. Shaft supporting portions **41dL** and **41dR** are respectively formed at the front side of the tray side plates **41L** and **41R** of the cartridge tray **40**, as illustrated in FIG. 10. A positioning shaft **49** is supported by the shaft supporting portions **41dL** and **41dR**. The positioning shaft **49** passes through the tray side plates **41L** and **41R**, with a left-side end portion **49a** and right-side end portion (omitted from illustration) of the positioning shaft **49** protruding to the outer side of the tray side plates **41L** and **41R**. Note that the positioning shaft **49** is immovably fixed to the shaft supporting portions **41dL** and **41dR**, but may be rotatably supported as long as it is not capable of moving in

the front-back direction and the up-down direction. Also, the positioning shafts **49** and **50** are configured of round rod-shaped shafts that extend in the right-left direction and have a circular cross-sectional shape, but the shapes thereof are not limited.

A shaft contact portion **42c** that supports the substantially middle portion of the positioning shaft **49** in the axial direction from beneath is formed on the linking member **42**. The shaft contact portion **42c** restricts downward deflection of the positioning shaft **49**. Note that the shaft contact portion **42c** is not limited to being at the substantially middle portion in the axial direction of the positioning shaft **49** and may support the positioning shaft **49** from below at another position. However, restricting downward deflection of the positioning shaft **49** at the middle portion of the positioning shaft **49** is suitable. Also, the shaft contact portion **42c** maybe formed long in the axial direction.

The positioning groove **36aR** of the main body side plate **36R** is formed following the insertion direction Y1 of the cartridge tray **40**, and has a fitting groove **37aR** formed at the deep side, and a guide groove **37bR** formed at the near side, as illustrated in FIG. 11D.

The fitting groove **37aR** has a width that is the same as or slightly smaller than the outer diameter of the positioning shaft **49**, and fits to the end portion **49a** of the positioning shaft **49** when the cartridge tray **40** is situated at a mounted position. The guide groove **37bR** has a width that is larger than the outer diameter of the positioning shaft **49**, and guides the end portion **49a** of the positioning shaft **49** to the fitting groove **37aR** when mounting the cartridge tray **40** to the apparatus main body **100A**. Note that a guide groove and a fitting groove are formed in the same way for the main body side plate **36L**, and guide and fit the left-side end portion of the positioning shaft **49**.

Positioning grooves **41bL** and **41bR** are respectively formed at the deep-sides of the tray side plates **41L** and **41R**, as illustrated in FIG. 5B. The positioning grooves **41bL** and **41bR** position the cartridge tray **40** by engaging the positioning shaft **49**. FIGS. 11A through 11C are enlarged views illustrating the positioning groove **41bR**. Note that since the positioning grooves **41bL** and **41bR** are of the same configuration, description will be made regarding the positioning groove **41bR** alone, and description of the positioning groove **41bL** will be omitted.

The positioning groove **41bR** has an inclined face **41f**, and a positioning face **41e** formed continuing from the inclined face **41f**, as illustrated in FIGS. 11A through 11C. The positioning face **41e** extends in a direction substantially perpendicular to the insertion direction Y1 of the cartridge tray **40**, and positions the cartridge tray **40** in the insertion direction by abutting the positioning shaft **50**. The inclined face **41f** inclines downward toward the insertion direction Y1. Also, a sliding face **46d** (see FIG. 5B) is formed on the linking member **46** of the cartridge tray **40**, with the sliding face **46d** being formed to continue from the inclined face **41f** to the near side.

When the cartridge tray **40** is mounted, the inclined face **41f** is subjected to reactive force F1 from the positioning shaft **50** due to downward force being applied from the own weight of the cartridge tray **40** and the pressing units **33** and **34** (see FIG. 14A), as illustrated in FIG. 11A. The reactive force F1 contains component force of the insertion direction Y1, and accordingly the cartridge tray **40** is drawn inward in the insertion direction Y1, and moves in a direction F2. Thus, the positioning face **41e** is pressed against the positioning shaft **50**, and can precisely position the cartridge tray

40 as to the apparatus main body 100A. In this way, the inclined face 41f is formed to generate component force.

The positioning shaft 50 is supported by the shaft supporting portions 50aL and 50aR of the main body side plates 36L and 36R, as illustrated in FIG. 12. In a state in which the cartridge tray 40 is mounted to the apparatus main body 100A, the positioning grooves 41bL and 41bR are situated on an inner side from the shaft supporting portions 50aL and 50aR in the axial direction. Accordingly, the middle portion of the positioning shaft 50 may exhibit downward (direction of outline arrow in FIG. 12) deflection under downward force from the own weight of the cartridge tray 40 and the pressing units 33 and 34 (see FIG. 14A).

Accordingly, a rib 46b is formed at the substantially middle portion of the linking member 46 in the axial direction (right-left direction) in the present embodiment. The rib 46b restricts downward deflection of the positioning shaft 50 by coming into contact with the substantially middle portion of the positioning shaft 50 in the axial direction and supporting from below. Note that the rib 46b is not limited to being at the substantially middle portion of the positioning shaft 50 in the axial direction and may support the positioning shaft 50 from below at another position thereof. However, restricting downward deflection of the positioning shaft 50 at the middle portion of the positioning shaft 50 is suitable. Also, the rib 46b may be formed long in the axial direction, or a plurality of ribs 46b may be provided along the axial direction. Also, although downward deflection is restricted in the present embodiment, since the positioning shaft 50 is subjected to force in the gravitational direction. However, the arrangement does not have to come into contact with the lower portion of the positioning shaft 50, as long as force in a direction of deflection of the positioning shaft 50 is received and deflection of the positioning shaft 50 is restricted.

Also, retaining portions 46c arranged to retain the fixing stay 35 are formed on the linking member 46, as illustrated in FIGS. 12 and 13. The retaining portions 46c can restrict downward deflection of the cartridge tray 40 including the linking member 46 by retaining the fixing stay 35. Suppressing downward deflection of the cartridge tray 40 also suppresses deformation of the cartridge tray 40 at the positioning grooves 41bL and 41bR, and the cartridge tray 40 can be precisely positioned as to the positioning shaft 50. Note that just one retaining portion 46c, or three or more retaining portions 46c may be provided without impeding the mounting operations of the cartridge tray 40. Also, one retaining portion 46c may be formed long in the axial direction (right-left direction).

Operations of Drawing Out and Mounting Cartridge Tray

Next, the operations of drawing out and mounting the cartridge tray 40 will be described. Once the developer in the process cartridges PPY, PPM, PPC, and PPK has been consumed to a degree where images of quality that satisfy the purchasing user can no longer be formed, the product value as process cartridges is lost.

Accordingly, an arrangement may be made in which unit (omitted from illustration) detecting remaining developer amount of each of the process cartridges is provided, for example, and the control portion 200 compares detected remaining amount values with threshold values set in advance, for cartridge lifespan notices and lifespan warnings. In this arrangement, a display regarding lifespan notice or lifespan warning regarding that process cartridge is displayed on a display portion (omitted from illustration) regarding process cartridges of which the detected remaining amount value is a remaining amount value below the

threshold value, prompting the user to replace the process cartridge. The user thereupon opens the front door 31 of the printer 100, draws out the cartridge tray 40 to the outside of the apparatus, and replaces the process cartridges PPY, PPM, PPC, and PPK. Operations of drawing out and mounting the cartridge tray 40 will be described below in detail.

The front door 31 is supported so as to be capable of opening and closing as to the apparatus main body 100A, as illustrated in FIGS. 14A through 15B. The opened state can be maintained by door links 32L and 32R linking between the front door 31 and the apparatus main body 100A.

When the user opens the front door 31, the transfer unit 12 rotates around 1° centered on the driving roller 14, by a plurality of link members that are omitted from illustration cooperatively moving via the door links 32L and 32R. Accordingly, the photosensitive drums 1 of the process cartridges are separated from the intermediate transfer belt 13, as illustrated in FIG. 16C.

Next, the main body developing contacts 38 provided to the left side (non-driving side) of the apparatus main body 100A are retracted from the cartridge developing contacts 2 electrically connected to the developing rollers 3 (see FIG. 3B), and pressure of the pressing units 33 and 34 is released, as illustrated in FIG. 20B. That is to say, the pressing unit 33 serving as a second pressing member moves from a second pressing position to a second separated position, and also the pressing unit 34 serving as a first pressing member moves from a first pressing position to a first separated position. Next, engagement of the drum couplings 1c at the driving side of the process cartridges and the developing couplings 3c (FIG. 3A) is disengaged, and also pressing of the cartridge tray 40 by tray pressing units 51 is released, as illustrated in FIGS. 14B and 16B. As a result, the cartridge tray 40 is in a state in which it can be removed to the outside of the apparatus main body 100A.

Now, the tray pressing units 51 are provided to each of holders 52L and 52R supported by the main body side plates 36L and 36R, and press the cartridge tray 40 toward the front side from the back side, when forming images. The tray pressing units 51 each has a tray pressing lever 53, a tray pressing link 54, and a biasing spring (omitted from illustration), as illustrated in FIGS. 16A and 16B.

The tray pressing lever 53 is pressed by the tray pressing link 54 that is biased by the biasing spring in a state in which the front door 31 is closed as illustrated in FIG. 16A. Thus, the tray pressing lever 53 presses a pressed portion 41c formed on the tray side plate 41R of the cartridge tray 40 rearward.

When the front door 31 is opened, the tray pressing lever 53 is retracted downward by the door links 32L and 32R, and by a link member that is omitted from illustration as illustrated in FIG. 16B. Accordingly, pressure of the tray pressing lever 53 toward the rear side of the cartridge tray 40 is released, and the cartridge tray 40 can be removed to the outside of the apparatus main body 100A.

Next, the movements of members in the proximity of the positioning shafts 49 and 50 will be described with reference to FIGS. 11A through 11F. Note, however, that the positioning configurations of the cartridge tray 40 regarding the positioning shafts 49 and 50 are the same on the right and left sides, and accordingly description will be made reading only the right side of the apparatus, and description of the left side of the apparatus will be omitted. When drawing out of the cartridge tray 40 is started, the inclined face 41f slides with respect to the positioning shaft 50, and accordingly the deep side of the cartridge tray 40 is raised slightly as illustrated in FIGS. 11A through 11F. The cartridge tray 40

then moves in a drawing out direction Y2 with the sliding face 46d provided to the linking member 46 of the cartridge tray 40 sliding with respect to the positioning shaft 50.

At the same time, the end portion 49a of the positioning shaft 49 of the cartridge tray 40 exits the fitting groove 37aR of the positioning groove 36aR, and is handed over to the guide groove 37bR. The cartridge tray 40 is drawn out in the drawing out direction Y2, with the end portion 49a of the positioning shaft 49 being guided by the guide groove 37bR. FIGS. 11A and 11D illustrate a state in which the cartridge tray 40 is situated at the mounted position. FIGS. 11B and 11E illustrate a state in which the cartridge tray 40 is drawn out around 3 mm from the mounted position. FIGS. 11C and 11F illustrate a state in which the cartridge tray 40 is drawn out around 10 mm from the mounted position.

When the cartridge tray 40 is drawn out to a certain degree, the cartridge tray 40 rides on and is guided by rollers 56L and 56R (first rotating member and second rotating member), as illustrated in FIGS. 14B and 15B. The cartridge tray 40 is thus drawn out to the outside of the apparatus main body 100A. Note when forming images, the cartridge tray 40 and the rollers 56L and 56R are not in contact with each other, and a clearance of around 0.5 mm is secured therebetween.

FIGS. 17A and 17B are diagrams illustrating the process of the cartridge tray being drawn out. The guide groove 47aL of the cartridge tray 40 is guided by a guide portion 32aL provided to the door link 32L. The configurations of the guide groove 47aR and a guide portion 32aR are the same as the configurations of the guide groove 47aL and the guide portion 32aL. Accordingly, even in cases in which the amount of drawing out of the cartridge tray 40 is great, the cartridge tray 40 can be smoothly drawn out, with inclination reduced. Also, the attitude of the cartridge tray 40 when being drawn out can be stabilized, thereby facilitating replacement of process cartridges.

The guide grooves 47aL and 47aR are formed as open-box shapes opening toward the outer side, provided on the outer side of the first supporting portion 41R1 and the second supporting portion 41L1 of the tray side plates 41L and 41R made of a metal material. Protruding portions 41L4 and 41R4 (first protruding portion and second protruding portion) extending toward the outer side from the first supporting portion 41R1 and the second supporting portion 41L1 are disposed below the guide grooves 47aL and 47aR. The guide grooves 47aL and 47aR are disposed between the outer side portions 41L2 and 41R2 and the protruding portions 41L4 and 41R4. In the mounting direction of the process cartridges to the cartridge tray 40, the guide groove 47aL is disposed on the downstream side of the cartridge engaging portions 41gL, 41hL, 41iL, and 41jL, and the guide groove 47aR is disposed on the downstream side of the cartridge engaging portions 41gR, 41hR, 41iR, and 41jR. Thus, a power guide can be configured. When the cartridge tray 40 is drawn out, the protruding portions 41L4 and 41R4 are supported riding on the rollers 56L and 56R.

Also, the guide grooves 47aL and 47aR are provided on the inner sides from the first outer side portion 41R2 and the second outer side portion 41L2 in the longitudinal direction of the photosensitive drum 1, and at least part thereof is situated between the first supporting portion 41R1 and the first outer side portion 41R2, and between the second supporting portion 41L1 and the second outer side portion 41L2, respectively, in the longitudinal direction. Accordingly, layout thereof is realized without increasing the size of the cartridge tray 40 and the image forming apparatus. The process cartridges can be mounted to the cartridge tray

40 by dropping the process cartridges in through the opening spreading outward at the top of the cartridge tray 40. The tray side plates 41L and 41R are provided with the first connecting portion 41R3 and the second connecting portion 41L3 that connect between the first supporting portion 41R1 and the second supporting portion 41L1, and the first outer side portion 41R2 and the second outer side portion 41L2. The first connecting portion 41R3 and the second connecting portion 41L3 have inclined faces that incline from the outer side of the mounting portion 40a toward the inner side, with respect to the longitudinal direction LD. More specifically, the inclined faces of the first connecting portion 41R3 and the second connecting portion 41L3 incline from the outer side of the mounting portion 40a toward the inner side, from the upstream side toward the downstream side in the mounting direction of the process cartridges PP. These inclined faces enable the process cartridges PP to be smoothly mounted to the cartridge tray 40.

The mounted process cartridges PP are positioned by the cartridge engaging portions 41gL, 41hL, 41iL, 41jL, 41gR, 41hR, 41iR, and 41jR of the tray side plates 41L and 41R. At this time, the grounding members 1b that are the cartridge contacts provided at the end portions of the photosensitive drums 1 come into contact with the wire members 48 that are contact members provided to the cartridge tray 40 for each of the process cartridges PP. The wire members 48 serve as intermediate contacts that electrically connect the photosensitive drums 1 and the main body frame 30 of the apparatus main body 100A, as tray contacts. The wire members 48 come into contact with a conducting line 59 below the cartridge engaging portions 41gL, 41hL, 41iL, and 41jL, and are connected to the main body side plate 36L of the main body frame 30 via the conducting line 59. That is to say, when the cartridge tray 40 is at the internal position of the apparatus main body 100A, the grounding members 1b are electrically connected to the apparatus main body 100A via the wire members 48 and the side plate 41L.

The wire members 48 each have an arm portion 48b that serves as a spring portion having spring properties, and a wound portion 48a wound following the insertion direction of the process cartridges PP at a contact portion with the grounding member 1b. The wound portion 48a is biased toward the side of the grounding member 1b by the spring properties of the arm portion 48b. The grounding member 1b and the wound portion 48a come into contact at a position on the upstream side of the cartridge engaging portions 41gL, 41hL, 41iL, and 41jL and the downstream side of the second outer side portion 41L2 in the direction of mounting the process cartridges to the cartridge tray 40. Meanwhile, the wound portion 48a is roughly positioned by a contact restricting portion 47eL provided to the guide member 47L being inserted into and passing through the wound portion 48a. Due to this contact restricting portion 47eL, the contact position of the grounding member 1b and the wound portion 48a is restricted to a predetermined position, even when no process cartridge is mounted to the mounting portion 40a. Further, by the wire members 48 being disposed lower than the second connecting portion 41L3, damage of the wire members 48 can be suppressed when inserting the process cartridges PP into the cartridge tray 40, and insertion of the process cartridges PP can be smoothly carried out. Also, by disposing the wire members 48 on the inner side from the second outer side portion 41L2 in the longitudinal direction of the photosensitive drums 1, layout thereof is realized without increasing the size of the cartridge tray 40 and the image forming apparatus.

The wire members **48** are disposed adjacent to the outer side of the second supporting portion **41L1** of the tray side plate **41L** in the longitudinal direction of the photosensitive drums **1**, and further the guide member **47L** having the guide groove **47aL** is provided on the outer side, thereby holding the wire members **48**. The wire members **48** are also electrically connected to the tray side plate **41L** that is made of a metal material, and as described later, the tray side plate **41L** and the positioning shafts **49** and **50** are connected, and the positioning shafts **49** and **50** and the main body frame **30** are connected. Thus, a sturdy grounding contact path is formed.

When the cartridge tray **40** is drawn out and process cartridges are replaced, the cartridge tray **40** is mounted to the apparatus main body **100A**. The mounting operation at the time of mounting the cartridge tray **40** to the apparatus main body **100A** is reverse to the operations of drawing out. At this time, the sliding face **46d** first begins sliding with respect to the positioning shaft **50**, and after the positioning shaft **50** moves beyond the sliding face **46d**, the end portion **49a** of the positioning shaft **49** is handed over from the guide groove **37bR** to the fitting groove **37aR**, as illustrated in FIGS. **11B** and **11E**.

The boundary portion between the guide groove **37bR** and the fitting groove **37aR** is an upward incline, and also the end portion **49a** of the positioning shaft **49** is fit to the fitting groove **37aR**, and accordingly the operating force exerted by the user at the time of mounting the cartridge tray **40** is great. However, the positioning shaft **49** enters the fitting groove **37aR** after the sliding face **46d** has moved beyond the positioning shaft **50**, and accordingly, the timing at which a great operating force is exerted by the user is not concentrated, and the operating force can be reduced. Note that in this configuration, when the cartridge tray **40** is inserted as far as a predetermined distance to the mounting position, the cartridge tray **40** is automatically taken up to the mounting position by a later-described take-up device.

When the cartridge tray **40** is inserted to the mounting position, and the front door **31** (opening/closing member) is closed, the tray pressing units **51** press the cartridge tray **40** to the deep side, as illustrated in FIGS. **14A**, **15A**, and **16A**. The drum couplings **1c** on the driving side of the process cartridges **PP** and the developing couplings **3c** (see FIG. **3A**) are engaged, and the pressing units **33** and **34** press the process cartridges **PP** from above.

FIGS. **18A** through **19C** are diagrams illustrating the pressing state of the pressing units **33** and **34** pressing the process cartridges. FIG. **18A** is a schematic perspective view partially cut along the longitudinal direction of the photosensitive drums **1** with regard to a contact between the main body developing contact **38** and the cartridge developing contact **2** connected to the developing roller **3**, and a contact between a pressing portion **33a** and a memory member **7**, at the left side of the process cartridge **PPK**. FIG. **18B** is a schematic diagram viewing the cut plane of FIG. **18A** in the direction of movement of the cartridge tray **40**. FIG. **18C** is a schematic diagram viewing a cut plane of the process cartridges and the cartridge tray **40** along a second imaginary plane **IFL** shown in FIG. **18B**, in the longitudinal direction of the photosensitive drums **1**. FIG. **19A** is schematic perspective view partially cut along the longitudinal direction of the photosensitive drums **1** with regard to the center of the drum coupling **1c** at the right side of the process cartridge **PPK**. FIG. **19B** is a schematic diagram viewing the cut plane of FIG. **19A** in the direction of movement of the cartridge tray **40**. FIG. **19C** is a schematic diagram viewing a cut plane of the process cartridges and the cartridge tray **40**

along a first imaginary plane **IFR** shown in FIG. **19B**, in the longitudinal direction of the photosensitive drums **1**.

Now, the pressing units **33** and **34** press the drum bearings **1aL** and **1aR** toward the cartridge engaging portions **41gL**, **41hL**, **41iL**, **41jL**, **41gR**, **41hR**, **41iR**, and **41jR**. The pressing unit **34** (first pressing member) is disposed to intersect the first imaginary plane **IFR** that is orthogonal to the longitudinal direction of the photosensitive drums **1** and intersects the cartridge engaging portions **41gR**, **41hR**, **41iR**, and **41jR** (first positioning members). The pressing unit **33** (second pressing member) is disposed to intersect the second imaginary plane **IFL** that is orthogonal to the longitudinal direction and intersects the cartridge engaging portions **41gL**, **41hL**, **41iL**, and **41jL** (second positioning members).

Further, as viewed from the longitudinal direction of the photosensitive drums **1**, part of contact portions (pressing portions) **39** that are portions where the pressing units **33** and **34** come into contact with the cartridges are disposed overlapping the cartridge engaging portions **41gL**, **41hL**, **41iL**, **41jL**, **41gR**, **41hR**, **41iR**, and **41jR** with respect to the pressing direction of the pressing units **33** and **34**. That is to say, the force of the pressing units **33** and **34** pressing the process cartridges is received by the cartridge engaging portions **41gL**, **41hL**, **41iL**, **41jL**, **41gR**, **41hR**, **41iR**, and **41jR** that are on a straight line therewith. Accordingly, the process cartridges can be strongly held and positioned in a stable manner.

Further, the shaft supporting portions **41dL** and **41dR** and the positioning grooves **41bL** and **41bR** of the tray side plates **41L** and **41R**, are provided on the same plane as the cartridge engaging portions **41gL**, **41hL**, **41iL**, **41jL**, **41gR**, **41hR**, **41iR**, and **41jR**, and are supported by the positioning shafts **49** and **50** (FIGS. **6A** through **7B**). Also, the pressing portions **33a** that are part of the contact portions **39** of the pressing unit **33** are also provided with contacts for the memory members **7** provided to the process cartridges **PP**, for storing various types of information such as operation history of the relevant process cartridge, performance information unique to the process cartridge, and so forth. By enabling strong holding and positioning of the process cartridges in a stable manner as described above, stable application of electricity and communication can be maintained.

Further, the pressing unit **33** is provided with main body charging contacts **37** for performing electric power supply to the charging rollers **5**, as illustrated in FIGS. **20A** and **20B**. The process cartridges **PP** have charging contacts **6** electrically connected to the charging rollers **5**. The main body charging contacts **37** are configured of wire members having the same configuration as the above-described wire members **48**, and are configured to be biased against the charging contacts **6** by the spring properties thereof and come into contact with the charging contacts **6**. FIGS. **20A** and **20B** are diagrams illustrating the positional relation between the power supply contact for electric power supply to the charging roller **5**, and the photosensitive drum **1** and the charging roller **5** and so forth. FIG. **20A** is a schematic perspective view illustrating the contact of the main body charging contact **37** and the charging contact **6** partially cut along the longitudinal direction of the photosensitive drum **1**, at the left side of the process cartridge **PPK**. FIG. **20B** is a schematic diagram viewing the cut plane in FIG. **20A** in the direction of movement of the cartridge tray **40**. The pressing unit **33** presses the process cartridges **PP** from above even at the portions where the main body charging contacts **37** are provided. The pressing unit **33** presses the process cartridges **PP** from above, and also the main body

21

charging contact 37 are positioned as to the charging contacts 6 of the process cartridges, thereby connecting the main body charging contacts 37 and the charging contacts 6. The main body charging contacts 37 are disposed at positions overlapping the photosensitive drums 1 and the charging rollers 5 in the longitudinal direction of the photosensitive drums 1. That is to say, the contact positions of the main body charging contacts 37 and the charging contacts 6 are disposed at positions overlapping the photosensitive drums 1 and the charging rollers 5 in the longitudinal direction of the photosensitive drums 1. Accordingly, the contact portions, the photosensitive drums 1, and the charging rollers 5 can be each accurately positioned as to each other, by the pressing unit 33 pressing in the proximity of the contacts of the main body charging contacts 37 and the charging contacts 6. That is to say, the process cartridges can be strongly held and positioned in a stable manner, whereby stable application of electricity can be maintained. Also, a sturdy and stable contact path can be formed in the proximity of the end portions of the photosensitive drums 1 and the charging rollers 5, and accordingly the contact paths within the process cartridges can be shortened, and the process cartridges can be manufactured inexpensively. Note that the main body charging contacts 37 and the charging contacts 6 are disposed between the first supporting portion 41R1 and the second supporting portion 41L1 in the longitudinal direction of the photosensitive drums 1.

As described above, after a state is entered in which the pressing units 33 and 34 press the process cartridges from above, the main body developing contacts 38 come into contact with the cartridge developing contacts 2 (see FIG. 3B) connected to the developing rollers 3, and the transfer units 12 rotate upwards, centered on the driving rollers 14. Thus, the photosensitive drum 1 of each process cartridge comes into contact with the intermediate transfer belt 13.

As described above, in a state in which the front door 31 is closed and the printer 100 is capable of forming images, the positioning shaft 50 and the positioning grooves 41bL and 41bR are engaged at the front side of the cartridge tray 40. The inclined faces 41f are provided to the positioning grooves 41bL and 41bR, and accordingly at this time, the cartridge tray 40 is drawn inward in the insertion direction Y1 on the basis of the own weight of the cartridge tray 40 and the downward force from the pressing units 33 and 34. Accordingly, the positioning faces 41e are pressed against the positioning shaft 50, and the cartridge tray 40 can be precisely positioned in the insertion direction Y1.

Also, at the rear side of the cartridge tray 40, the positioning shaft 49 and the positioning grooves 36aL and 36aR are engaged. At this time, the end portions 49a of the positioning shaft 49 fit into the fitting grooves of the positioning grooves 36aL and 36aR, and accordingly the cartridge tray 40 can be suppressed from rotating in a direction orthogonal to the mounting direction Y1, i.e., centered on the positioning shaft 50.

The above positioning shaft 50 and the positioning grooves 36aL and 36aR provided to the apparatus main body 100A, and the positioning grooves 41bL and 41bR and the positioning shaft 49 provided to the cartridge tray 40, make up a positioning mechanism 60 (see FIGS. 11A and 11D). The positioning mechanism 60 positions the cartridge tray 40 as to the apparatus main body 100A.

Further, the positioning shaft 50 is supported from below by the rib 46b provided to the linking member 46 of the cartridge tray 40, whereby downward deflection of the positioning shaft 50 is restricted. Also, deformation of the cartridge tray 40 itself is suppressed by the retaining por-

22

tions 46c provided to the linking member 46. The positioning shaft 49 at the back side of the cartridge tray 40 is also supported from below by the shaft contact portion 42c, thereby restricting downward deflection of the positioning shaft 49. According to such a configuration, the positioning shafts 49 and 50 may be formed with a smaller shaft diameter, or made from an inexpensive resin material, and accordingly costs and size can be reduced.

According to these, the cartridge tray 40 can be precisely positioned as to the apparatus main body 100A at the mounting position. In particular, the process cartridges held in the cartridge tray 40 are pressed from the upper side by the pressing units 33 and 34 at the time of forming images, but the precision of positioning of the cartridge tray 40 is not affected. Accordingly, the precision of positions of the process cartridges held in the cartridge tray 40, specifically the positional precision between the photosensitive drums 1 and the intermediate transfer belt 13 is improved, and high-quality images can be formed.

Also, due to the operations of the inclined faces 41f at the front side of the cartridge tray 40, and the pressing of the tray pressing units 51 at the back side, the cartridge tray 40 is biased toward the front side in the mounting position. Accordingly, positional deviation of the cartridge tray 40 due to vibrations and so forth at the time of forming images can be reduced. Also, by generating force of pressing in at the front and rear of the cartridge tray 40, the force of pressing inward is dispersed, and the elastic force of the biasing spring of the tray pressing units 51 can be kept small. Accordingly, the size and cost of the tray pressing units 51 can be reduced.

According to the present invention, cartridges can be positioned to side plates of the tray unit in a stable manner by the above configuration.

Also, according to the present invention, tray contacts of the tray unit to be electrically connected to cartridge contacts of cartridges can be laid out while conserving space.

Further, according to the present invention, guide grooves of the tray unit guided by the apparatus main body can be laid out while conserving space.

Note that which of the apparatus main body 100A and the cartridge tray 40 that the positioning shaft 50 and the positioning grooves 41bL and 41bR included in the positioning mechanism 60 belong to may be switched, as long as one is disposed in one and the other is disposed in the other. Also, which of the apparatus main body 100A and the cartridge tray 40 that the positioning shaft 49 and the positioning grooves 36aL and 36aR included in the positioning mechanism 60 belong to may be switched, as long as one is disposed in one and the other is disposed in the other.

Also, the positioning shaft 49 is not limited to being a through shaft over the entire length of the cartridge tray 40 in the right-left direction. It is sufficient for two protrusions to be formed protruding outward to both sides of the cartridge tray 40.

Although the drum units OP and the developing units DP are integrally formed in the process cartridges, these may be configured separately. The cartridge tray 40 may hold only the drum units OP, or hold only the developing units DP, for example.

While the present invention has been described with reference to exemplary embodiments, it is to be understood that the invention is not limited to the disclosed exemplary embodiments. The scope of the following claims is to be accorded the broadest interpretation so as to encompass all such modifications and equivalent structures and functions.

23

This application claims the benefit of Japanese Patent Application No. 2020-136229, filed on Aug. 12, 2020, No. 2020-136143, filed on Aug. 12, 2020, No. 2020-136209, filed on Aug. 12, 2020, which are hereby incorporated by reference herein in its entirety.

What is claimed is:

1. An image forming apparatus configured to perform an image forming operation, the image forming apparatus comprising:

a cartridge including a first roller, a first positioned portion, a second positioned portion, and a roller contact electrically connected to the first roller, wherein with respect to a longitudinal direction of the cartridge, the first positioned portion is closer to a first end of the cartridge than to a second end of the cartridge opposite to the first end, and the second positioned portion is closer to the second end than to the first end;

an apparatus main body including a main body contact, the main body contact configured to contact and press the roller contact;

a mounting unit to which the cartridge is detachably mounted, the mounting unit including a first positioning portion and a second positioning portion, wherein the first positioning portion contacts the first positioned portion and the second positioning portion contacts the second positioned portion so that the cartridge is positioned to an image forming position while the image forming operation is performed,

wherein a position at which the main body contact and the roller contact come into contact is located between the first positioning portion and the second positioning portion in the longitudinal direction of the cartridge.

2. The image forming apparatus according to claim 1, the cartridge includes a second roller configured to rotate about a rotation axis,

wherein the longitudinal direction is a direction parallel to a direction of the rotation axis.

3. The image forming apparatus according to claim 2, the second roller is a photosensitive drum.

4. The image forming apparatus according to claim 3, the first roller is a charging roller configured to charge the photosensitive drum.

5. The image forming apparatus according to claim 2, the second roller is a developing roller.

6. The image forming apparatus according to claim 5, the cartridge includes a photosensitive drum, and wherein the first roller is a charging roller configured to charge the photosensitive drum.

7. The image forming apparatus according to claim 1, the position at which the main body contact and the roller contact come into contact overlaps a position of the first roller with respect to the longitudinal direction.

8. The image forming apparatus according to claim 1, the apparatus main body includes a pressing member configured to press the cartridge.

9. The image forming apparatus according to claim 1, the cartridge includes a cartridge end contact disposed at an end portion of the cartridge with respect to the longitudinal direction.

10. The image forming apparatus according to claim 9, further comprising:

an end contact configured to electrically connect to the cartridge end contact.

11. The image forming apparatus according to claim 10, wherein the apparatus main body includes the end contact.

24

12. The image forming apparatus according to claim 1, wherein the main body contact configured to press the roller contact from above the roller contact.

13. The image forming apparatus according to claim 1, wherein the cartridge including a memory member configured to store information, and the apparatus main body including a pressing member including a memory contact, the pressing member configured to press the memory member.

14. The image forming apparatus according to claim 13, wherein the main body contact configured to press the roller contact from above the roller contact.

15. The image forming apparatus according to claim 14, wherein the pressing member configured to press the memory member from above the memory member.

16. The image forming apparatus according to claim 1, wherein the mounting unit includes a first side plate including the first positioning portion, and a second plate including the second positioning portion.

17. The image forming apparatus according to claim 16, the first side plate is made of metal.

18. The image forming apparatus according to claim 17, the second side plate is made of metal.

19. The image forming apparatus according to claim 1, wherein the mounting unit is configured to be capable of moving with respect to the apparatus main body, between an internal position situated within the apparatus main body and an external position situated outside of the apparatus main body in a direction crossing to the longitudinal direction.

20. The image forming apparatus according to claim 1, the mounting unit is a mounting unit to which multiple cartridges are detachably attached, the multiple cartridges include the cartridge.

21. The image forming apparatus according to claim 1, further comprising:

a door attached to the apparatus main body, the door being capable of moving between (i) a closed position of covering the mounting unit situated within the apparatus main body and (ii) an open position of exposing the mounting unit situated within the apparatus main body; and

a pressing unit including the main body contact, the pressing unit being movable in interrelation with movement of the door.

22. The image forming apparatus according to claim 21, wherein the pressing unit is capable of moving between a pressing position of pressing the cartridge and a separated position of being separated from the cartridge in interrelation with the movement of the door.

23. The image forming apparatus according to claim 1, wherein the main body contact and the roller contact opposite to each other in a direction crossing to the orthogonal direction in a state where the main body contact contacts and presses the roller contact.

24. An image forming apparatus configured to perform an image forming operation, the image forming apparatus comprising:

a cartridge including a first roller, a second roller configured to rotate about a rotation axis, a first positioned portion, a second positioned portion, and a roller contact electrically connected to the first roller, wherein with respect to a direction of the rotation axis, the first positioned portion is closer to a first end of the cartridge than to a second end of the cartridge opposite to the first end, and the second positioned portion is closer to the second end than to the first end;

25

an apparatus main body including a main body contact, the main body contact configured to contact and press the roller contact;

a mounting unit to which the cartridge is detachably mounted, the mounting unit including a first positioning portion and a second positioning portion, wherein the first positioning portion contacts the first positioned portion and the second positioning portion contacts the second positioned portion so that the cartridge is positioned to an image forming position while the image forming operation is performed,

wherein a position at which the main body contact and the roller contact come into contact is located between the first positioning portion and the second positioning portion in the direction of the rotation axis.

25. The image forming apparatus according to claim 24, the second roller is a photosensitive drum.

26. The image forming apparatus according to claim 25, the first roller is a charging roller configured to charge the photosensitive drum.

27. The image forming apparatus according to claim 24, the second roller is a developing roller.

28. The image forming apparatus according to claim 27, the cartridge includes a photosensitive drum, and wherein the first roller is a charging roller configured to charge the photosensitive drum.

29. The image forming apparatus according to claim 24, the position at which the main body contact and the roller contact come into contact overlaps a position of the first roller with respect to the direction of the rotation axis.

30. The image forming apparatus according to claim 24, the apparatus main body includes a pressing member configured to press the cartridge.

31. The image forming apparatus according to claim 24, the cartridge includes a cartridge end contact disposed at an end portion of the cartridge with respect to the direction of the rotation axis.

32. The image forming apparatus according to claim 31, further comprising:
an end contact configured to electrically connected to the cartridge end contact.

33. The image forming apparatus according to claim 32, wherein the apparatus main body includes the end contact.

34. The image forming apparatus according to claim 24, wherein the main body contact configured to press the roller contact from above the roller contact.

35. The image forming apparatus according to claim 24, wherein the cartridge including a memory member configured to store information, and the apparatus main body

26

including a pressing member including a memory contact, the pressing member configured to press the memory member.

36. The image forming apparatus according to claim 35, wherein the main body contact configured to press the roller contact from above the roller contact.

37. The image forming apparatus according to claim 36, wherein the pressing member configured to press the memory member from above the memory member.

38. The image forming apparatus according to claim 24, wherein the mounting unit includes a first side plate including the first positioning portion, and a second plate including the second positioning portion.

39. The image forming apparatus according to claim 38, the first side plate is made of metal.

40. The image forming apparatus according to claim 39, the second side plate is made of metal.

41. The image forming apparatus according to claim 24, wherein the mounting unit is configured to be capable of moving with respect to the apparatus main body, between an internal position situated within the apparatus main body and an external position situated outside of the apparatus main body in a direction crossing to the direction of the rotation axis.

42. The image forming apparatus according to claim 24, the mounting unit is a mounting unit to which multiple cartridges are detachably attached, the multiple cartridges include the cartridge.

43. The image forming apparatus according to claim 24 further comprising:

a door attached to the apparatus main body, the door being capable of moving between (i) a closed position of covering the mounting unit situated within the apparatus main body and (ii) an open position of exposing the mounting unit situated within the apparatus main body; and

a pressing unit including the main body contact, the pressing unit being movable in interrelation with movement of the door.

44. The image forming apparatus according to claim 43, wherein the pressing unit is capable of moving between a pressing position of pressing the cartridge and a separated position of being separated from the cartridge in interrelation with the movement of the door.

45. The image forming apparatus according to claim 24, wherein the main body contact and the roller contact opposite to each other in a direction crossing to the orthogonal direction in a state where the main body contact contacts and presses the roller contact.

* * * * *