



(51) International Patent Classification:

H01C 7/12 (2006.01) *B29C 70/18* (2006.01)
B29C 70/52 (2006.01) *B29C 70/02* (2006.01)
B29C 63/06 (2006.01)

(21) International Application Number:

PCT/US2016/065510

(22) International Filing Date:

8 December 2016 (08.12.2016)

(25) Filing Language:

English

(26) Publication Language:

English

(30) Priority Data:

14/976,468 21 December 2015 (21.12.2015) US

(71) Applicant: **COOPER TECHNOLOGIES COMPANY** [US/US]; 600 Travis St. #5600, Houston, Texas 77002 (US).

(72) Inventors: **RAMARGE, Michael, M.**; 701 Grandview Avenue, Olean, New York 14760 (US). **SMITH, Timothy, S.**; 9412 Jenmar Drive, Fuquay Varina, North Carolina 27526 (US). **MARTIN, Jeremy, L.**; 8606 County Road 1, Friendship, New York 14739 (US).

(74) Agents: **LEVY, Philip, E.** et al.; Eckert Seamans Cherin & Mellott, LLC, 600 Grant Street, 44th Floor, Pittsburgh, Pennsylvania 15219 (US).

(81) Designated States (unless otherwise indicated, for every kind of national protection available): AE, AG, AL, AM, AO, AT, AU, AZ, BA, BB, BG, BH, BN, BR, BW, BY, BZ, CA, CH, CL, CN, CO, CR, CU, CZ, DE, DJ, DK, DM, DO, DZ, EC, EE, EG, ES, FI, GB, GD, GE, GH, GM, GT, HN, HR, HU, ID, IL, IN, IR, IS, JP, KE, KG, KH, KN, KP, KR, KW, KZ, LA, LC, LK, LR, LS, LU, LY, MA, MD, ME, MG, MK, MN, MW, MX, MY, MZ, NA, NG, NI, NO, NZ, OM, PA, PE, PG, PH, PL, PT, QA, RO, RS, RU, RW, SA, SC, SD, SE, SG, SK, SL, SM, ST, SV, SY, TH, TJ, TM, TN, TR, TT, TZ, UA, UG, US, UZ, VC, VN, ZA, ZM, ZW.

(84) Designated States (unless otherwise indicated, for every kind of regional protection available): ARIPO (BW, GH, GM, KE, LR, LS, MW, MZ, NA, RW, SD, SL, ST, SZ, TZ, UG, ZM, ZW), Eurasian (AM, AZ, BY, KG, KZ, RU, TJ, TM), European (AL, AT, BE, BG, CH, CY, CZ, DE, DK, EE, ES, FI, FR, GB, GR, HR, HU, IE, IS, IT, LT, LU, LV, MC, MK, MT, NL, NO, PL, PT, RO, RS, SE, SI, SK, SM, TR), OAPI (BF, BJ, CF, CG, CI, CM, GA, GN, GQ, GW, KM, ML, MR, NE, SN, TD, TG).

Published:

— with international search report (Art. 21(3))

(54) Title: HOLLOW CORE ARRESTER STRENGTH MEMBRANE

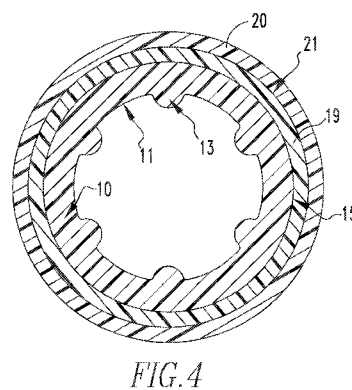
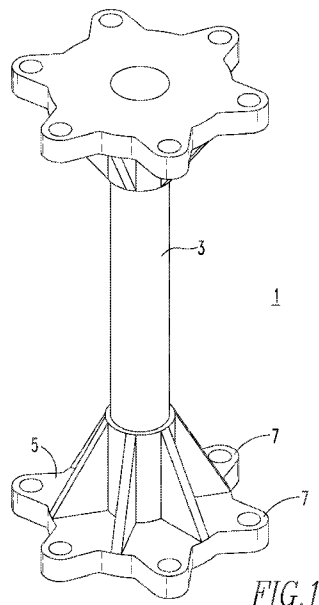

(57) Abstract: The disclosed concept relates to hollow core arrester membranes generally and, in particular, to membranes that include a pultruded tube composed of fibers and resin, and one or more wrap layers composed of fibers and resin in the form of a mat or fabric. The one or more wrap layers are applied to the pultruded tube to form a wrapped, pultruded tube, which is over molded with a polymer enclosure.



WO 2017/112418 A1

HOLLOW CORE ARRESTER STRENGTH MEMBRANE

CROSS-REFERENCE TO RELATED APPLICATION

This application claims priority from and claims the benefit of U.S.
5 Patent Application Serial No. 14/976,468, filed December 21, 2015, which is
incorporated by reference herein.

BACKGROUND

Field

The disclosed concept pertains generally to arresters and, in particular,
10 to hollow core arrester membranes structured to exhibit high strength in both
longitudinal and radial directions.

Background Information

Electrical transmission and distribution equipment is subject to
15 voltages within a fairly narrow range under normal operating conditions. However,
system disturbances, such as lightning strikes and switching surges, may produce
momentary or extended voltage levels that greatly exceed the levels experienced by
the equipment during normal operating conditions. These voltage variations often are
referred to as over-voltage conditions.

20 If not protected from over-voltage conditions, critical and expensive
equipment, such as transformers, switching devices, computer equipment, and
electrical machinery, may be damaged or destroyed by over-voltage conditions and
associated current surges. Accordingly, it is routine practice for system designers to
use surge arresters to protect system components from dangerous over-voltage
25 conditions.

A surge arrester is a protective device that is commonly connected in
parallel with a comparatively expensive piece of electrical equipment so as to shunt or
divert over-voltage-induced current surges safely around the equipment, thereby
protecting the equipment and its internal circuitry from damage. When exposed to an
30 over-voltage condition, the surge arrester operates in a low impedance mode that
provides a current path to electrical ground having a relatively low impedance. The
surge arrester otherwise operates in a high impedance mode that provides a current

path to ground having a relatively high impedance. The impedance of the current path is substantially lower than the impedance of the equipment being protected by the surge arrester when the surge arrester is operating in the low-impedance mode, and is otherwise substantially higher than the impedance of the protected equipment.

5 Upon completion of the over-voltage condition, the surge arrester returns to operation in the high impedance mode. This prevents normal current at the system frequency from following the surge current to ground along the current path through the surge arrester.

 Conventional surge arresters typically include an elongated outer
10 enclosure or housing made of an electrically insulating material and a pair of electrical terminals at opposite ends of the enclosure for connecting the arrester between a line-potential conductor and electrical ground, and an array of other electrical components that form a series electrical paths between the terminals. The electrically insulating materials can be selected from those known in the art for use in
15 arrester housings, such as, ceramic (e.g., porcelain) and polymer (e.g., rubber material including silicon rubber and ethylene propylene diene monomer (EPDM) rubber). The other components typically include a stack of voltage-dependent, nonlinear resistive elements, referred to as varistors. A varistor is characterized by having a relatively high resistance when exposed to a normal operating voltage, and a much
20 lower resistance when exposed to a larger voltage, such as is associated with over-voltage conditions. In addition to varistors, a surge arrester also may include one or more spark gap assemblies housed within the insulative enclosure and electrically connected in series with the varistors. Some arresters also include electrically
conductive spacer elements coaxially aligned with the varistors and gap assemblies.

25 For proper arrester operation, contact must be maintained between the components of the stack. To accomplish this, it is known to apply an axial load to the elements of the stack. Good axial contact is important to ensure a relatively low contact resistance between the adjacent faces of the elements, to ensure a relatively uniform current distribution through the elements, and to provide good heat transfer
30 between the elements and the end terminals.

 One way to apply this load is to employ springs within the housing to urge the stacked elements into engagement with one another. Another way to apply

the load is to wrap the stack of arrester elements with glass fibers so as to axially-compress the elements within the stack.

The disclosed concept provides a polymer membrane for housing stacked elements in a hollow core arrester that exhibits improved alignment capability and mechanical strength, while being capable of manufacture at a low cost.

SUMMARY

In one aspect, the disclosed concept includes an arrester membrane having a hollow core for housing stacked electrical elements, which includes a pultruded tube having a plurality of protrusions extending into the hollow core, the pultruded tube includes a plurality of fibers; and resin, wherein the plurality of fibers are impregnated into the resin and said plurality of fibers are at least predominately oriented in a longitudinal direction; at least one wrap layer applied to an outer surface of the pultruded tube, the at least one wrap layer including a plurality of fibers; and resin, wherein the plurality of fibers are impregnated into the resin to form a mat or fabric, and said plurality of fibers are at least predominately oriented in a radial direction; and an outer enclosure applied to a surface of the at least one wrap layer, the outer enclosure comprising polymer.

The plurality of fibers can comprise glass fibers. The resin can be selected from the group consisting of polyester, polyurethane, vinyl ester, epoxy and mixtures thereof. In certain embodiments, the resin is epoxy.

The polymer can be a rubber material. In certain embodiments, the rubber material is selected from the group consisting of silicone rubber.

The plurality of protrusions can be in a hemispherical shape. In certain embodiments, the pultruded tube and the plurality of protrusions are fabricated into a single part.

In certain embodiments, at least one wrap layer is applied to the outer surface of the pultruded tube by wrapping and curing. The outer enclosure can be applied to the outer surface of the at least one wrap layer by over molding. The at least one wrap layer can include at least one winding, or the at least one wrap layer can include multiple windings. Further, there can be multiple wrap layers.

In certain embodiments, the pultruded tube has a higher glass fiber to resin ratio than the at least one wrap layer. The pultruded tube can have a cantilever strength of at least 70,000 in-lbs. For the pultruded tube, the glass fibers can constitute from about 50% to about 90% by weight, and the resin can constitute from about 20% to about 25% by weight, based on total weight of the pultruded tube. For the at least one wrap layer, the glass fibers can constitute from about 25% to about 60% by weight, and the resin can constitute about 40% by weight, based on total weight of the layer.

The membrane can be structured to have a burst strength that withstands energy generated during a 65 kA electrical fault current.

In another aspect, the disclosed concept provides a method of making an arrester membrane having a hollow core for housing stacked electrical elements. The method includes forming a pultruded tube by impregnating resin with glass fibers in a pultrusion process in a tubular shape having a plurality of protrusions extending into the hollow core, the glass fibers being at least predominately oriented in a longitudinal direction; forming at least one wrap layer by impregnating resin with glass fibers to form a mat or fabric, the glass fibers being at least predominately oriented in a radial direction; wrapping the mat or fabric onto an outer surface of the pultruded tube, wherein the wrapping comprises one or more windings; curing; and forming an outer enclosure by over molding the at least one wrap layer with polymer.

The at least one wrap layer can include multiple wrap layers and the outer enclosure can be formed by over molding a final wrap layer.

BRIEF DESCRIPTION OF THE DRAWINGS

A full understanding of the disclosed concept can be gained from the following description of the preferred embodiments when read in conjunction with the accompanying drawings in which:

FIG. 1 is an isometric view of a pultruded, wrapped tube of a hollow core arrester membrane, in accordance with certain embodiments of the disclosed concept;

FIG. 2 is a cross section of a pultruded tube of a hollow core arrester membrane, in accordance with certain embodiments of the disclosed concept;

FIG. 3 is a cross-section view the pultruded tube of FIG. 2 further including a wrapped layer, in accordance with certain embodiments of the disclosed concept;

5 FIG. 4 is a cross-section view the pultruded tube of FIG. 3 further including a second wrapped layer, in accordance with certain embodiments of the disclosed concept;

FIG. 5 is a schematic showing a configuration of fibers in resin for a pultruded tube of a hollow core arrester membrane, in accordance with certain embodiments of the disclosed concept;

10 FIG. 6 is a schematic showing a configuration of fibers in resin for a wrapped layer of a hollow core arrester membrane, in accordance with certain embodiments of the disclosed concept;

FIG. 7 is a cross-section view of the pultruded tube of FIG. 3 further including an enclosure, in accordance with certain embodiments of the disclosed
15 concept.

DESCRIPTION OF THE PREFERRED EMBODIMENTS

For purposes of the description hereinafter, directional phrases used herein such as, for example, “top”, “bottom”, “front”, “back”, “behind”, “side”,
20 “right”, “left”, “upper”, “lower”, and derivatives thereof shall relate to the disclosed concept, as it is oriented in the drawings. It is to be understood that the specific elements illustrated in the drawings and described in the following specification are simply exemplary embodiments of the disclosed concept. Therefore, specific orientations and other physical characteristics related to the embodiments disclosed
25 herein are not to be considered limiting with respect to the scope of the disclosed concept.

As employed herein, the term “number” shall mean one or an integer greater than one (*i.e.*, a plurality).

30 As employed herein, the statement that two or more parts are “connected” together shall mean that the parts are joined together either directly or joined through one or more intermediate parts.

The disclosed concept relates to arresters and, in particular, to hollow core arrester membranes or composites that provide high strength in both longitudinal and radial directions. Various arrester designs are known in the art. More than one arrester can be employed and the arresters can be stacked. Also known are various
5 elongated outer enclosures or housings made of an electrically insulating material that contain an array of electrical components that form the arrester. For example, a pair of electrical terminals at opposite ends of the enclosure can connect the arrester between a line-potential conductor and electrical ground, a stack of voltage-
dependent, nonlinear resistive elements, e.g., varistors, and one or more spark gap
10 assemblies.

There are various types of arresters for use in different power systems, which have voltage ratings associated therewith. In accordance with the disclosed concept, the arresters have a voltage rating of about 3 KV and higher or preferably, from about 230 KV to about 1100 KV.

15 The disclosed concept includes hollow core arrester membranes that include a tube formed by pultrusion and one or more layers formed by wrapping or winding resin-impregnated fabric, e.g., “pre-preg”, such as, in the form of a mat, onto an outer surface of the pultruded tube.

FIG. 1 shows a wrapped, pultruded tube 1 in accordance with certain
20 embodiments of the disclosed concept. The tube 1 is formed in the shape of an elongated cylinder 3. The length of the cylinder 3 can vary and, typically, the length is about four feet or less. As shown in FIG. 1, each end of the cylinder 3 is connected to an end fitting 5 having a plurality of holes 7 formed therein. The cylinder 3 can be
secured to a surface utilizing fasteners, e.g., bolts or screws (not shown), in the
25 plurality of holes 7. Each end fitting 5 may be selected from various mechanisms that are known in the art. An end fitting 5 is typically manufactured and selected to withstand a particular force or exhibit a particular strength, and the fasteners are
selected in accordance therewith. Further, mechanisms for connecting the end fitting
5 to each end of the cylinder 3 may be selected from those known in the art. In
30 certain embodiments, an adhesive material is used.

FIG. 2 is a cross section of a pultruded tube 10. FIG. 2 shows a hollow core 9 of the tube 10, an inner surface 11 and an outer surface 15. The inner surface

11 includes a plurality of protrusions 13. Electrical components and elements (not shown) are contained, e.g., stacked, within the hollow core 9. The inner surface 11 is effective to enclose the electrical components and elements, and the plurality of protrusions 13 serves as a centering device to contribute to the vertical alignment of the stacked electrical components and elements. The plurality of protrusions 13, as shown in FIG. 2, include six hemisphere-shaped protrusions, however, it is contemplated that more or less than six protrusions can be used, and it is further understood that a wide variety of other shapes may be formed. The number of protrusions and the shape of the protrusions are not limiting, and are selected such that they are capable of maintaining alignment of the electrical components and elements stacked within the hollow core 9 of the tube 10.

The pultruded tube 10 is composed of a plurality of fibers coated with a resin and formed into a tubular shape using pultrusion apparatus and processes. The term “pultrusion” refers to the actions of “pull” and “extrusion”. In general, reinforcement material, such as, fibers, are impregnated with resin and pulled through a heated stationary die wherein the resin undergoes polymerization. The impregnation can be accomplished by either pulling the reinforcement material through a bath or by injecting the resin into a chamber that typically is connected to the die. A wide variety of fibers and resins known in the art are suitable for use in the pultrusion process. Suitable fibers include glass fibers and, suitable resins include polyester, polyurethane, vinyl ester, epoxy and combinations or mixtures thereof. In certain embodiments, the pultruded tube 10 is composed of glass fibers and epoxy.

As shown in FIG. 2, the plurality of protrusions 13 are integrated with the inner surface 11 of the pultruded tube 10, such as to form a single piece or part. Thus, the plurality of protrusions 13 can be formed during the pultrusion process in forming the pultruded tube 10. As a result, a separate centering device, e.g., rod or rubber inserts, which are known in the prior art for use in arresters, are not needed for alignment in the disclosed concept.

The amount of the fiber component and the resin component of the pultruded tube can vary. In certain embodiments, the pultruded tube includes from about 75% to about 80% by weight glass fibers and from about 20% to about 25% by weight resin, based on total weight of the tube. In general, the amount of the glass

fiber component is selected at about 90% or less, due to the likelihood of processing difficulties when the glass fiber component exceeds about 90%. Further, in general, the amount of the fiber component is selected at about 50% or greater, due to the likelihood of mechanical weakness when the glass fiber component is less than about 50%.

FIG. 3 is a cross section of the pultruded tube 10 as shown in FIG. 2. FIG. 3 shows the hollow core 9, the inner surface 11, the plurality of protrusions 13 and the outer surface 15 as shown in FIG. 2. In addition, FIG. 3 shows a first layer 19 that is wrapped onto the outer surface 15 of the pultruded tube 10. In certain embodiments, the first layer 19 is wrapped or wound onto the outer surface 15 of the pultruded tube 10 by use of conventional wrapping/winding apparatus and techniques. It is typical, after wrapping the first layer 19 onto the pultruded tube 10 to heat the wrapped, pultruded tube to an elevated temperature sufficient to cure, e.g., polymerize, the mat or fabric and therefore, bond the first layer 19 to the outer surface 15.

The first layer 19 includes a mat or fabric composed of glass fibers and resin, such as, epoxy. The resin can be selected from those known in the art and above-described herein. The glass fibers and resin, e.g., epoxy, for the first layer 19 may be the same or different from the glass fibers and resin, e.g., epoxy, used for the pultruded tube 10. As described above, both of the pultruded tube 10 and the first layer 19 are composed of glass fibers and resin. The pultruded tube 10 has a glass fiber to resin ratio that is larger than the glass fiber to resin ratio of the first layer 19. Thus, the pultruded tube 10 is a more dense material than the first layer 19. The first layer 19 can have the form of an open weave material.

The amount of the fiber component and the resin component of the first layer 19 (e.g., pre-preg resin coated fiber matrix) can vary. In certain embodiments, the first layer 19 includes about 60% glass fibers and about 40% resin, based on total weight of the layer. In general, the amount of the glass fiber component is selected at about 70% or less, or about 65% or less, due to the likelihood of processing difficulties when the glass fiber component exceeds about 70% or about 65%. Further, in general, the amount of the glass fiber component is

selected at about 25% or greater, due to the likelihood of mechanical weakness when the glass fiber component is less than about 25%.

The first layer 19 can include a single winding or multiple windings of the mat or fabric. The wrap to weft ratio can vary. Further, subsequent layers (in
5 addition to the first layer 19) may be applied to the pultruded tube 10. For example, a second layer can be wrapped or wound onto an outer surface of the first layer 19 and, a third layer can be wrapped or wound onto an outer surface of the second layer. Each additional layer can include a single winding or multiple windings.

FIG. 4 is a cross section of the pultruded tube 10 shown in FIG. 3 that
10 includes the first layer 19. In addition, FIG. 4 includes a second layer 20, which is also composed of glass fibers and resin in the form of a mat or fabric (as described above for the first layer 19). The second layer 20 is wrapped or wound onto the outer surface 21 of the first layer 19 by use of conventional wrapping/winding apparatus and techniques. It is typical for the second layer 20 to be wrapped or wound onto the
15 first layer 19 prior to curing the first layer 19, such that, after wrapping the second layer 20 onto the first layer 19, heating takes place to an elevated temperature sufficient to cure, e.g., polymerize, the mat or fabric and therefore, bond the first and second layers 19,20. The mat or fabric of the second layer 20 is different from the mat or fabric of the layer 19. That is, the second layer 20 has a composition that is
20 different from the first layer 19 and may exhibit different properties or characteristics. For example, the difference between the first and second layers 19,20 may be one or more of the following: fiber composition, resin composition, ratio of fiber to resin and orientation of the fibers.

In certain embodiments, as above-mentioned, one or more subsequent
25 layers can be applied to the second layer 20. For example, a third layer may be applied to the outer surface of the second layer 20 using the procedure described above for the first and second layers 19 and 20, respectively.

FIG. 5 shows a view of a pultruded tube material 30, in accordance with certain embodiments of the disclosed concept. As shown in FIG. 5, a plurality of
30 fibers 23 are impregnated into a resin 24. Furthermore, the plurality of fibers 23 are oriented in a longitudinal direction as shown by the arrow.

FIG. 6 shows a view of a wrap material 40, in accordance with certain embodiments of the disclosed concept. As shown in FIG. 6, a plurality of fibers 25 are impregnated into a resin 26. Furthermore, the plurality of fibers 25 are oriented in a radial direction as shown by the arrow. As shown in FIG. 6, each and every one of the plurality of fibers 25 are oriented in a radial direction. However, it is understood that in practice, the plurality of fibers 25 may be predominantly oriented in a radial direction and therefore, some of the plurality of fibers 25 may not be oriented in a radial direction.

In general, it has been found that the pultruded tube provides about 70% to about 80% of the cantilever strength but only about 15% to about 30% of the radial (burst) strength.

The pultruded tube in combination with one or more layers of the wrap material (e.g., pre-preg) can provide a cantilever strength that exceeds 80,000 in-lbs. The burst/radial strength is typically determined by the arrester product that passes a 65 kA or greater electrical fault current test, and not necessarily a stated or known mechanical requirement. A large amount of energy is generated during testing in an attempt to burst the product. In practice, an arrester product is required to pass at least a 65 kA fault current test and, preferably, a 80 kA fault current test. In certain embodiments, a mechanical structure, such as an arrester, which is based on a pultruded tube with a glass fiber content of at least 50% that is over-wound with a glass fiber mat, achieves a cantilever strength of at least 70,000 in-lbs., while also providing the burst strength required to withstand the energy generated during a 65 kA electrical fault current.

FIG. 7 is a cross section of the pultruded tube 10 as shown in FIG. 3. FIG. 7 shows the hollow core 9, the inner surface 11, the plurality of protrusions 13, the outer surface 15 and the first layer 19 as shown in FIG. 3. In addition, FIG. 7 includes an outer enclosure 29 formed on the outer surface 21 (as shown in FIG. 4) of the first layer 19. It is contemplated and understood, as described above, that more than one wrap layer may be applied to the pultruded tube 10 (such as the second layer 20 shown in FIG. 4) and therefore, the outer enclosure 29 is formed on an outer surface of the final wrap layer. The outer enclosure 29 is composed of polymer, such as, rubber material, which includes but is not limited to silicon rubber, ethylene

propylene diene monomer (EPDM) rubber, and mixtures or combinations thereof. In certain embodiments of the disclosed concept, the outer enclosure 29 is formed by over molding the first layer 19 with the polymer. Conventional injection molding apparatus and techniques known in the art are suitable for use in the disclosed
5 concept.

While specific embodiments of the disclosed concept have been described in detail, it will be appreciated by those skilled in the art that various modifications and alternatives to those details could be developed in light of the overall teachings of the disclosure. Accordingly, the particular arrangements
10 disclosed are meant to be illustrative only and not limiting as to the scope of the disclosed concept which is to be given the full breadth of the claims appended and any and all equivalents thereof.

What is Claimed is:

1. An arrester membrane having a hollow core for housing stacked electrical elements, comprising:

a pultruded tube (10) having a plurality of protrusions (13) extending into the hollow core (9), the pultruded tube (10) comprising:

a plurality of fibers (23); and
resin (24),

wherein the plurality of fibers (23) are impregnated into the resin (24) and said plurality of fibers (23) are at least predominately oriented in a longitudinal direction;

at least one wrap layer (19) applied to an outer surface (15) of the pultruded tube (10), the at least one wrap layer (19) comprising:

a plurality of fibers (25); and
resin (26),

wherein the plurality of fibers (25) are impregnated into the resin (26) to form a mat or fabric, and said plurality of fibers (25) are at least predominately oriented in a radial direction; and

an outer enclosure (29) applied to a surface of the at least one wrap layer (19), the outer enclosure (29) comprising polymer.

2. The arrester membrane of claim 1, wherein the plurality of fibers (23,25) comprise glass fibers.

3. The arrester membrane of claim 1, wherein the resin (24,26) is selected from the group consisting of polyester, polyurethane, vinyl ester, epoxy and mixtures thereof.

4. The arrester membrane of claim 1, wherein the polymer is a rubber material.

5. The arrester membrane of claim 1, wherein the plurality of protrusions (13) are in a hemispherical shape.
6. The arrester membrane of claim 1, wherein the pultruded tube (10) and the plurality of protrusions (13) are fabricated into a single part.
7. The arrester membrane of claim 1, wherein the at least one wrap layer (19) comprises at least one winding.
8. The arrester membrane of claim 7, wherein the at least one wrap layer (19) comprises multiple windings.
9. The arrester membrane of claim 1, wherein the pultruded tube (10) has a higher glass fiber to resin ratio than the at least one wrap layer (19).
10. The arrester membrane of claim 1, wherein the pultruded tube (10) has a cantilever strength of at least 70,000 in-lbs.
11. The arrester membrane of claim 1, wherein for the pultruded tube (10), the glass fibers constitute from about 50% to about 90% by weight, and the resin constitutes from about 20% to about 25% by weight, based on total weight of the pultruded tube (10).
12. The arrester membrane of claim 1, wherein for the at least one wrap layer (19), the glass fibers constitute from about 25% to about 60% by weight, and the resin constitutes about 40% by weight, based on total weight of the layer.
13. The arrester membrane of claim 1, wherein said membrane is structured to have a burst strength that withstands energy generated during a 65 kA electrical fault current.

14. A method of making an arrester membrane having a hollow core for housing stacked electrical elements, comprising:

forming a pultruded tube (10) by impregnating resin (24) with glass fibers in a pultrusion process in a tubular shape having a plurality of protrusions (13) extending into the hollow core (9), the glass fibers being at least predominately oriented in a longitudinal direction;

forming at least one wrap layer (19) by impregnating resin (26) with glass fibers to form a mat or fabric, the glass fibers being at least predominately oriented in a radial direction;

wrapping the mat or fabric onto an outer surface (15) of the pultruded tube (1), wherein the wrapping comprises one or more windings;

curing; and

forming an outer enclosure (29) by over molding the at least one wrap layer (19) with polymer.

15. The method of claim 14, wherein the at least one wrap layer (19) comprises multiple wrap layers and the outer enclosure (29) is formed by over molding a final wrap layer.

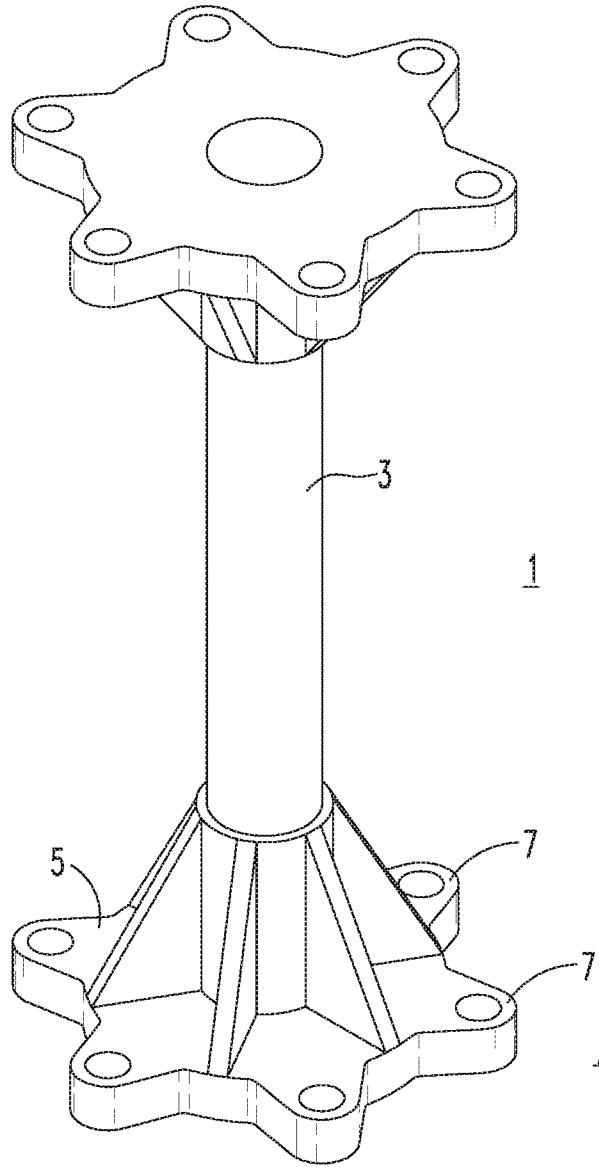

FIG. 1

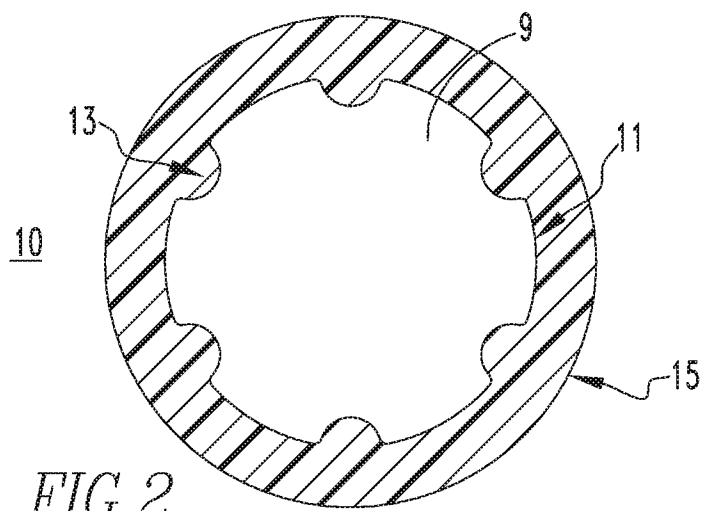

FIG. 2

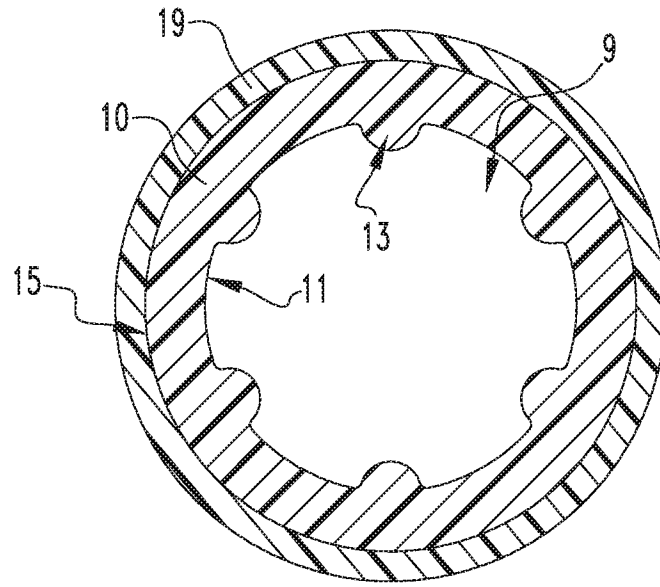

FIG. 3

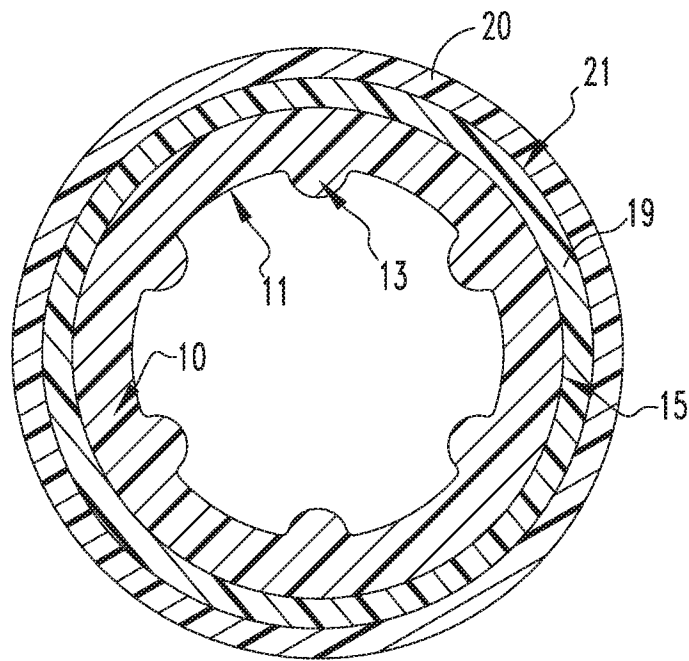

FIG. 4

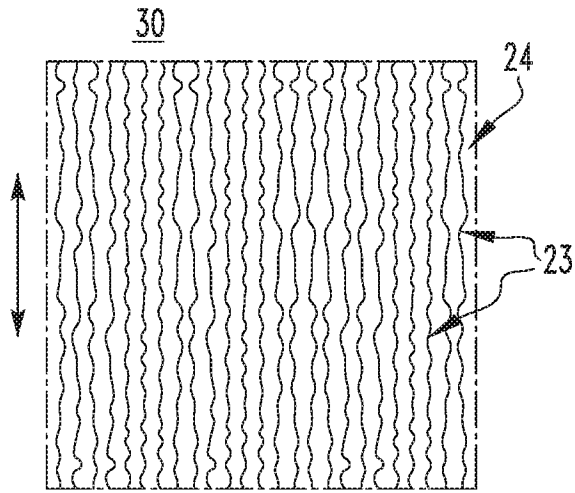

FIG. 5

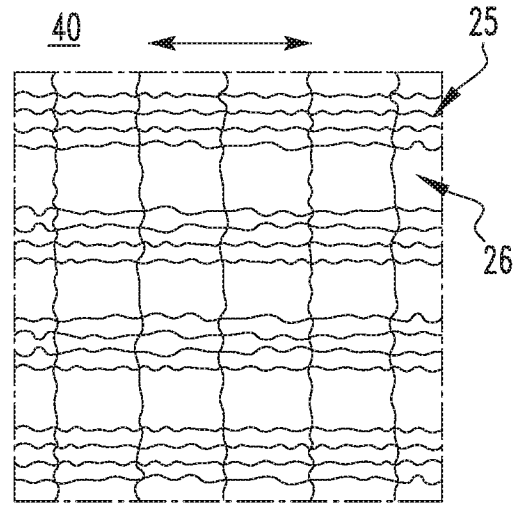

FIG. 6

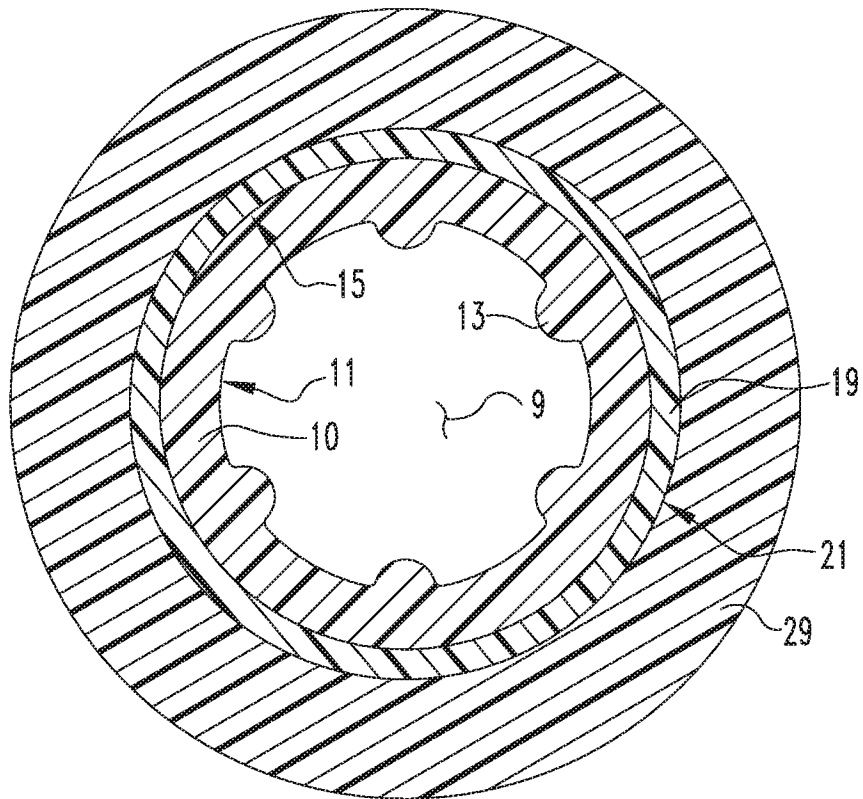

FIG. 7

INTERNATIONAL SEARCH REPORT

International application No PCT/US2016/065510

A. CLASSIFICATION OF SUBJECT MATTER
 INV. H01C7/12 B29C70/52 B29C63/06 B29C70/18 B29C70/02
 ADD.

According to International Patent Classification (IPC) or to both national classification and IPC

B. FIELDS SEARCHED

Minimum documentation searched (classification system followed by classification symbols)
 H01C B29C

Documentation searched other than minimum documentation to the extent that such documents are included in the fields searched

Electronic data base consulted during the international search (name of data base and, where practicable, search terms used)

EPO-Internal, WPI Data

C. DOCUMENTS CONSIDERED TO BE RELEVANT

Category*	Citation of document, with indication, where appropriate, of the relevant passages	Relevant to claim No.
A	US 2003/090850 A1 (RAMARGE MICHAEL M [US] ET AL) 15 May 2003 (2003-05-15) paragraph [0060] - paragraph [0065]; figures 8, 11,12 -----	1-15
A	JP H01 209685 A (OTOWA ELECTRIC; CENTRAL RES INST ELECT; REIKEMU KK) 23 August 1989 (1989-08-23) abstract; figures 1,2 -----	1-15
A	JP 3 376774 B2 (MEIDENSHA ELECTRIC MFG CO LTD) 10 February 2003 (2003-02-10) abstract; figures 1A-B -----	1-15
A	EP 1 143 460 A1 (TOSHIBA KK [JP]) 10 October 2001 (2001-10-10) paragraph [0062] - paragraph [0065]; figures 4A-D -----	1-11
	----- -/--	

Further documents are listed in the continuation of Box C.

See patent family annex.

* Special categories of cited documents :

"A" document defining the general state of the art which is not considered to be of particular relevance
 "E" earlier application or patent but published on or after the international filing date
 "L" document which may throw doubts on priority claim(s) or which is cited to establish the publication date of another citation or other special reason (as specified)
 "O" document referring to an oral disclosure, use, exhibition or other means
 "P" document published prior to the international filing date but later than the priority date claimed

"T" later document published after the international filing date or priority date and not in conflict with the application but cited to understand the principle or theory underlying the invention

"X" document of particular relevance; the claimed invention cannot be considered novel or cannot be considered to involve an inventive step when the document is taken alone

"Y" document of particular relevance; the claimed invention cannot be considered to involve an inventive step when the document is combined with one or more other such documents, such combination being obvious to a person skilled in the art

"&" document member of the same patent family

Date of the actual completion of the international search

3 April 2017

Date of mailing of the international search report

11/04/2017

Name and mailing address of the ISA/

European Patent Office, P.B. 5818 Patentlaan 2
 NL - 2280 HV Rijswijk
 Tel. (+31-70) 340-2040,
 Fax: (+31-70) 340-3016

Authorized officer

Frias Rebelo, Artur

INTERNATIONAL SEARCH REPORT

International application No PCT/US2016/065510

C(Continuation). DOCUMENTS CONSIDERED TO BE RELEVANT

Category*	Citation of document, with indication, where appropriate, of the relevant passages	Relevant to claim No.
A	JP 2003 303706 A (OTOWA ELECTRIC) 24 October 2003 (2003-10-24) abstract; figures 1-4 -----	1-15
A	US 4 467 387 A (BERGH DANIEL D [US] ET AL) 21 August 1984 (1984-08-21) column 4, line 30 - column 5, line 23; figures 2, 3,6 -----	1-15
A	US 2003/157285 A1 (BUSSHOFF MARIO [DE] ET AL) 21 August 2003 (2003-08-21) paragraph [0036] - paragraph [0053]; figures 1-4 -----	1-15

INTERNATIONAL SEARCH REPORT

Information on patent family members

International application No PCT/US2016/065510

Patent document cited in search report	Publication date	Patent family member(s)	Publication date
US 2003090850 A1	15-05-2003	AU 1225601 A US 6519129 B1 US 2003090850 A1 WO 0133581 A2	14-05-2001 11-02-2003 15-05-2003 10-05-2001

JP H01209685 A	23-08-1989	JP 3012884 B2 JP H01209685 A	28-02-2000 23-08-1989

JP 3376774 B2	10-02-2003	JP 3376774 B2 JP H0963807 A	10-02-2003 07-03-1997

EP 1143460 A1	10-10-2001	BR 0101329 A CN 1317807 A EP 1143460 A1 JP 4342078 B2 JP 2001291606 A KR 20010091041 A TW 594805 B	06-11-2001 17-10-2001 10-10-2001 14-10-2009 19-10-2001 22-10-2001 21-06-2004

JP 2003303706 A	24-10-2003	NONE	

US 4467387 A	21-08-1984	NONE	

US 2003157285 A1	21-08-2003	BR 0300273 A CA 2416841 A1 MX PA03000897 A US 2003157285 A1 US 2004103976 A1	03-08-2004 19-08-2003 03-09-2004 21-08-2003 03-06-2004
