



US 20230323758A1

(19) **United States**

(12) **Patent Application Publication**  
**Williams et al.**

(10) **Pub. No.: US 2023/0323758 A1**

(43) **Pub. Date: Oct. 12, 2023**

(54) **LINER SYSTEM AND METHOD**

(71) Applicants: **Jeffrey Williams**, Cypress, TX (US);  
**Andy Tom**, Houston, TX (US);  
**Matthew Krueger**, Cypress, TX (US)

(72) Inventors: **Jeffrey Williams**, Cypress, TX (US);  
**Andy Tom**, Houston, TX (US);  
**Matthew Krueger**, Cypress, TX (US)

(73) Assignee: **Baker Hughes Oilfield Operations LLC**, Houston, TX (US)

(21) Appl. No.: **17/716,693**

(22) Filed: **Apr. 8, 2022**

**Publication Classification**

(51) **Int. Cl.**  
*E21B 43/10* (2006.01)  
*E21B 33/129* (2006.01)

(52) **U.S. Cl.**

CPC ..... *E21B 43/108* (2013.01); *E21B 33/1293* (2013.01); *E21B 43/106* (2013.01)

(57) **ABSTRACT**

A hanger system including an expandable liner, an expandable first slip subsystem disposed about the liner, an expandable second slip subsystem disposed about the liner, a seal disposed about the liner and between the first slip subsystem and the second slip subsystem, and an expandable lock ring disposed about the liner and against one of the first slip subsystem or the second slip subsystem. A method for lining a borehole including running a liner system into a borehole, landing the liner system in a liner hanger, expanding the first slip subsystem simultaneously with a portion of the liner, expanding the second slip subsystem simultaneously with another portion of the liner, and sealing the liner to the liner hanger between the first slip subsystem and the second slip subsystem with the seal. A borehole system including a borehole in a subsurface formation, a casing in the borehole, and a liner system.

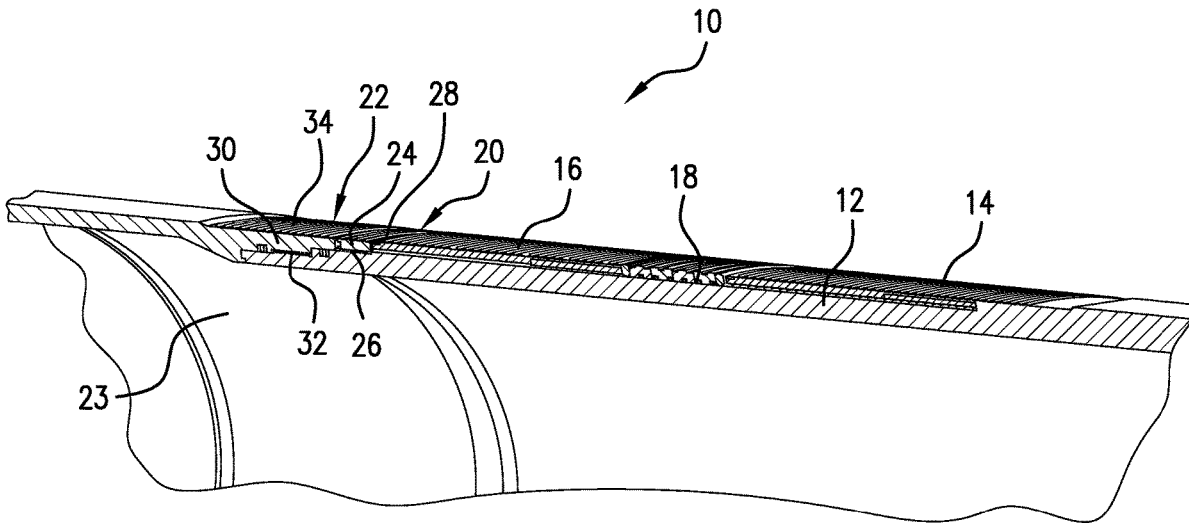

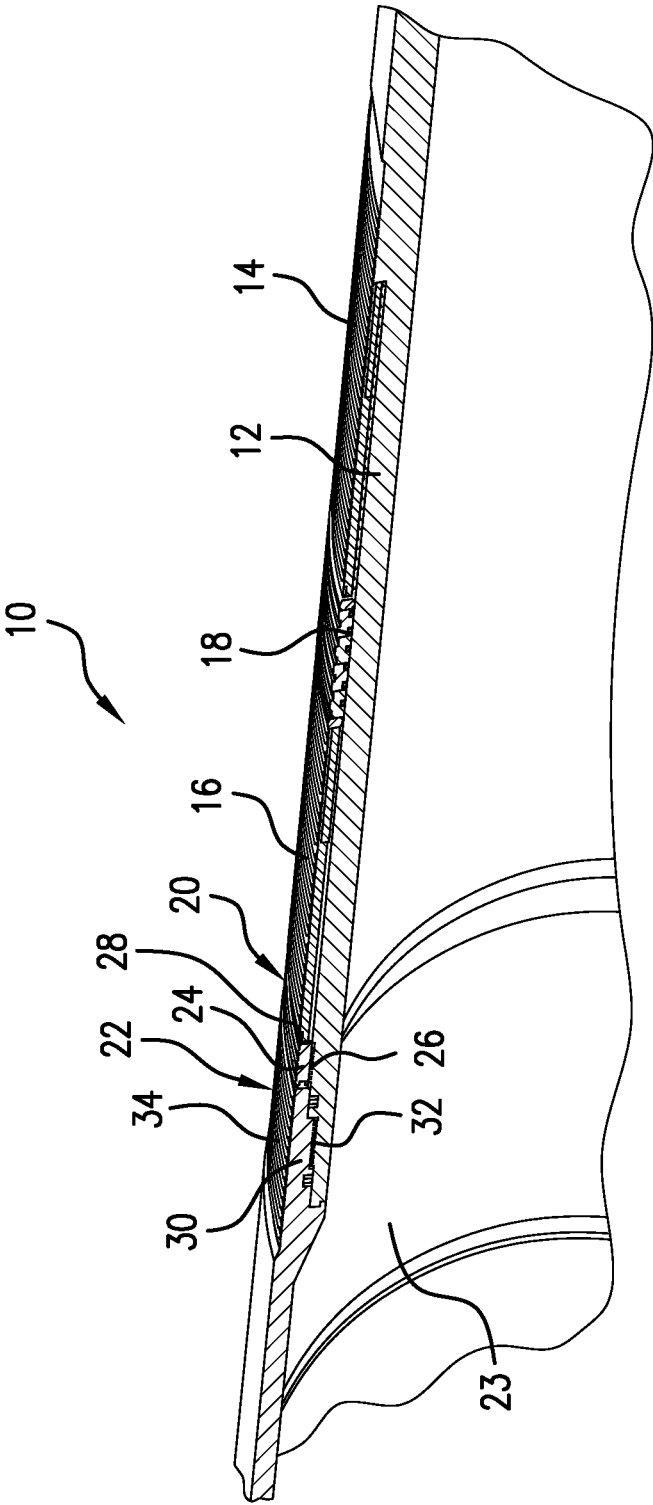

FIG.1

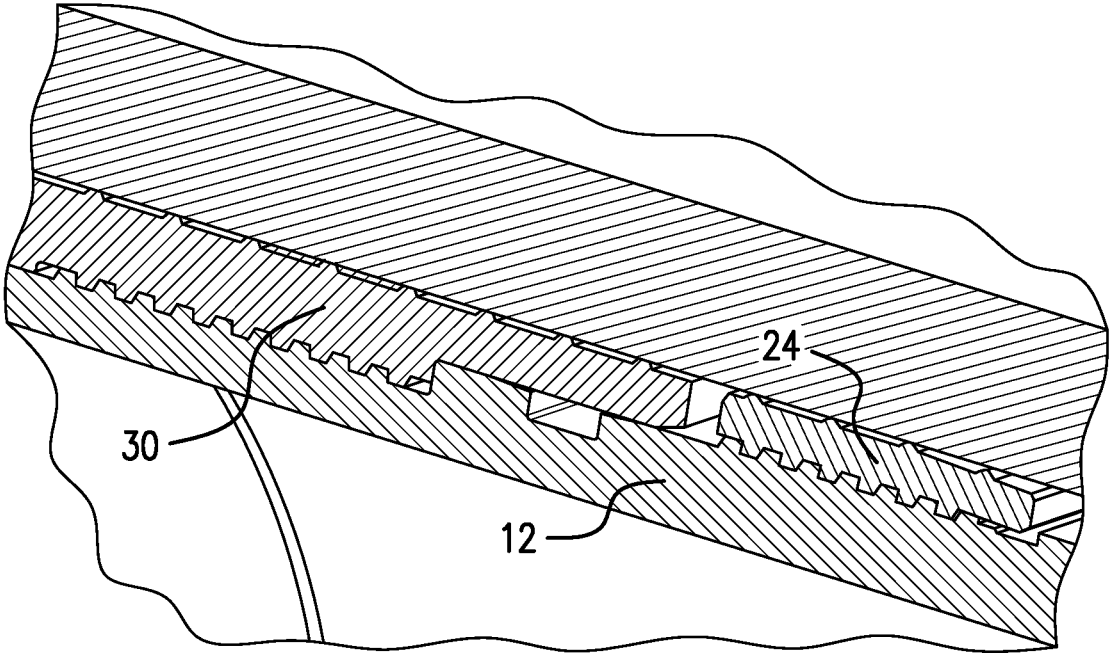

FIG. 2

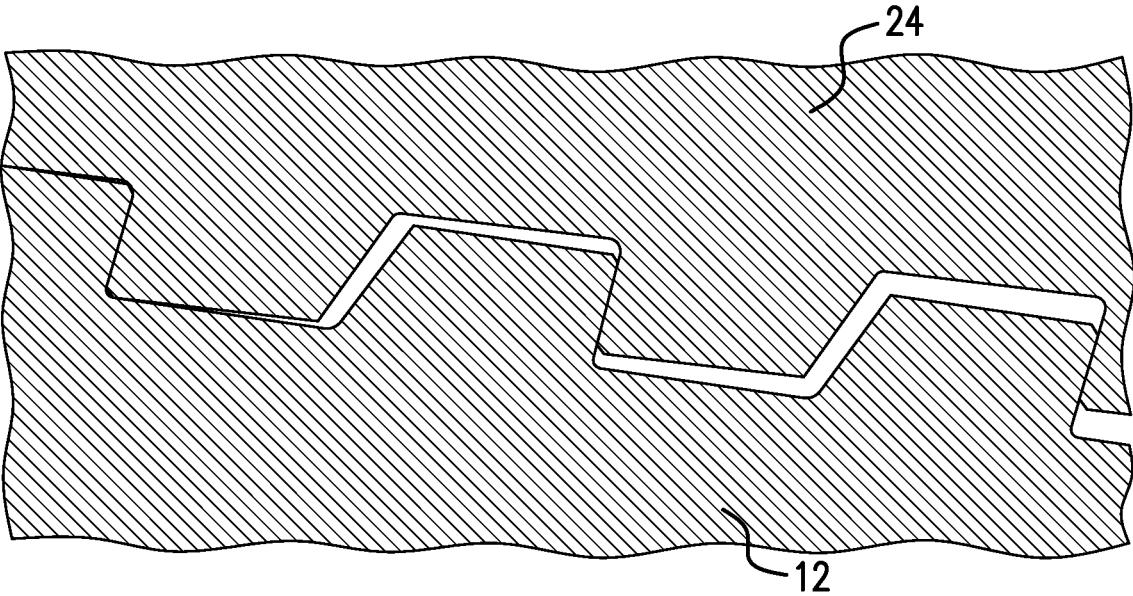

FIG. 3

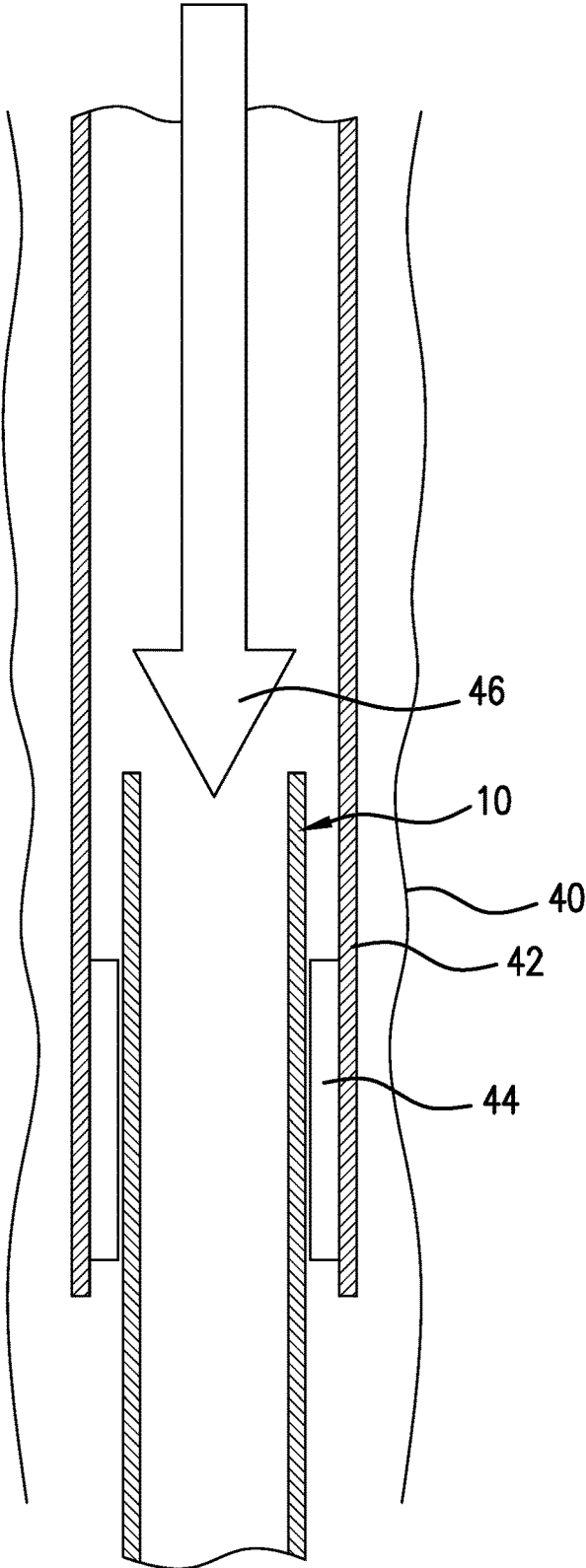

FIG.4

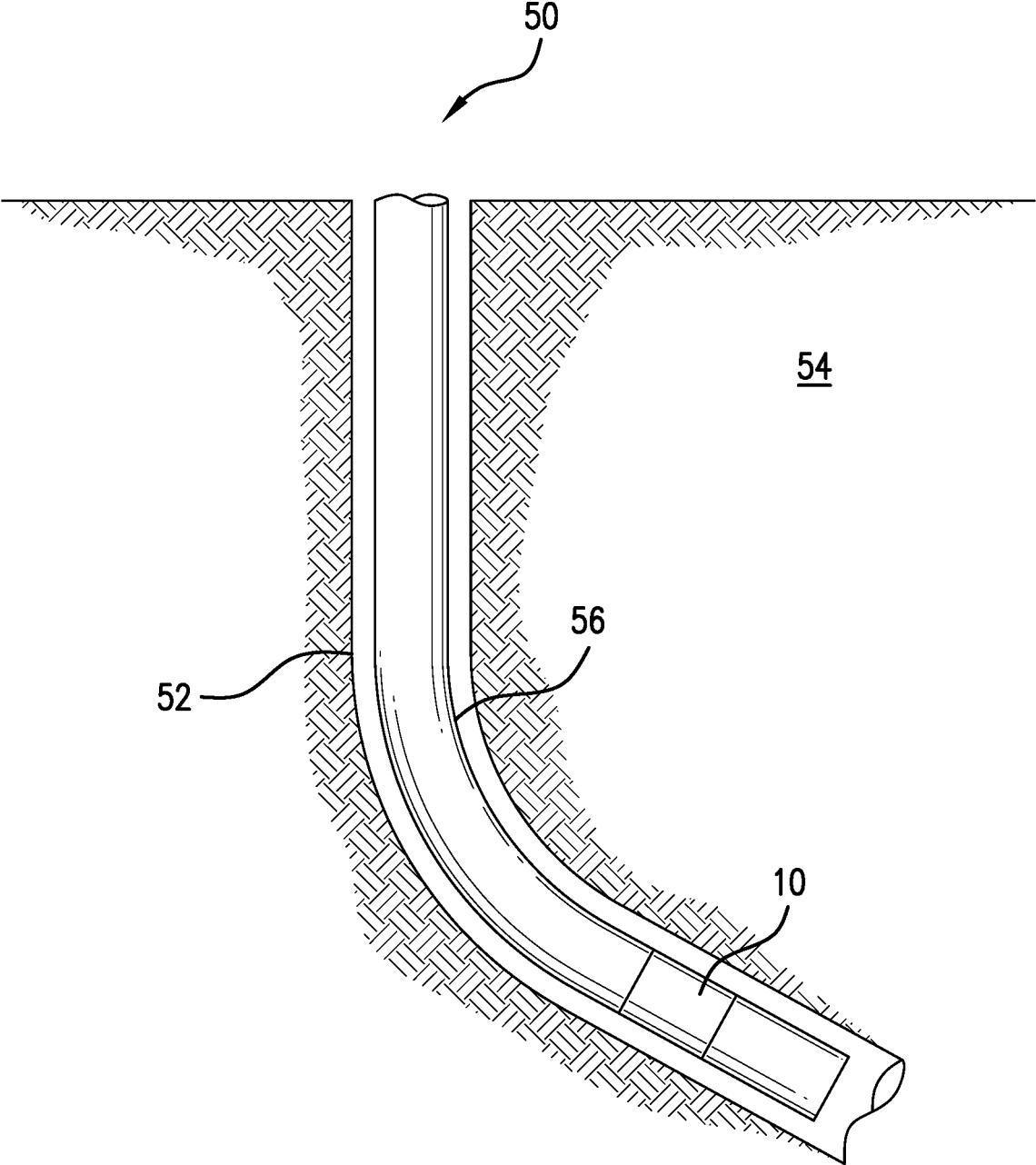

FIG.5

## LINER SYSTEM AND METHOD

### BACKGROUND

[0001] In the resource recovery and fluid sequestration industries, there is often need to install liners in boreholes. While liner configurations are well known and have been installed in many ways, there is still a concern regarding pressure issues that can have an undesirable impact on reliability at the hanger and concerns about collapse and burst ratings. The art will well receive alternatives that improve reliability and also improve burst and collapse ratings.

### SUMMARY

[0002] An embodiment of a hanger system including an expandable liner, an expandable first slip subsystem disposed about the liner, an expandable second slip subsystem disposed about the liner, a seal disposed about the liner and between the first slip subsystem and the second slip subsystem, and an expandable lock ring disposed about the liner and against one of the first slip subsystem or the second slip subsystem.

[0003] An embodiment of a method for lining a borehole including running a liner system into a borehole, landing the liner system in a liner hanger, expanding the first slip subsystem simultaneously with a portion of the liner, expanding the second slip subsystem simultaneously with another portion of the liner, and sealing the liner to the liner hanger between the first slip subsystem and the second slip subsystem with the seal.

[0004] An embodiment of a borehole system including a borehole in a subsurface formation, a casing in the borehole, and a liner system disposed within the casing.

### BRIEF DESCRIPTION OF THE DRAWINGS

[0005] The following descriptions should not be considered limiting in any way. With reference to the accompanying drawings, like elements are numbered alike:

[0006] FIG. 1 is a perspective view of an expandable liner system as disclosed herein;

[0007] FIG. 2 is a view illustrating the expansion threads;

[0008] FIG. 3 illustrated how the threads move under deformation;

[0009] FIG. 4 is a schematic view of the liner system disclosed herein being set in a borehole; and

[0010] FIG. 5 is a view of a borehole system including the expandable liner system disclosed herein.

### DETAILED DESCRIPTION

[0011] A detailed description of one or more embodiments of the disclosed apparatus and method are presented herein by way of exemplification and not limitation with reference to the Figures.

[0012] Referring to FIG. 1, a perspective section view of an expandable liner system 10 is illustrated. The system comprises a liner 12, a first slip subsystem 14, a second slip subsystem 16, a seal 18 located between the first and second slip subsystems 14, 16, a lock ring 20 and an anchor 22. During consideration of the system 10 it is to be appreciated that all components are assembled from one end of the liner 12. This provides a distinct advantage over prior art systems in that slip and burst/collapse ratings are higher due to the fact that there is no lapping thread in the liner below a hanger

upon which the system 10 is hung as there is in the prior art. The liner 12 in system 10 is full thickness below the hanger (not shown this figure) and thereby capable of burst and collapse ratings much higher than would be a liner with a threadform cut therein. Further, the anchor 22 may be configured with a polished bore 23 therein that is still above the hanger while still supporting assembly from the one end of the liner as noted above.

[0013] System 10 includes both a first and second slip subsystem 14, 16 with the seal 18 therebetween because the assembly protects load capacity rating. Seal 18 prevents pressure events from one side of the system 10 from reaching both of the slip subsystems. Therefore, were a pressure event to occur from downhole of the system 10, the liner 12 might be compressed to some extent that could undermine the engagement of the first slip system 14 with the hanger causing that slip subsystem to have a significantly lower load capacity rating. Seal 18 however, prevents that pressure event from also compromising the second slip subsystem 16 and rather allows that system to remain in perfect working order, thereby maintaining the load capacity rating. Alternatively, if a pressure event occurred uphole of the system 10, the casing (not shown this figure) could balloon, thereby undermining the rating of the second slip subsystem 16 by reducing the engagement of the second slip subsystem 16 with the hanger. The second slip subsystem would therefore be derated in this condition but due to the seal 18, the first slip subsystem 14 would be unaffected by the pressure event and hence would maintain the full load capacity rating.

[0014] From FIG. 1, it is also apparent that the slip subsystems 14, 16 and the seal 18 are tightly packaged axially (“axially” being used to refer to the longitudinal extent of the liner 12) upon the liner 12. The slip subsystems and the seal are maintained in this position for run in by the lock ring 20. Lock ring 20 includes a lock ring body 24, an inside surface thread 26 and an outside surface wicker 28. Thread 26 is to be mated to a matching male thread 27 (see FIGS. 2 and 3) on an outside surface of the liner 12. Threads 26 and 27 are required to remain engaged both pre and post expansion of the liner 12. During expansion, threads are moved and stretched such that commonly a subset of the total number of threads are actually engaged. In some cases, which can be understood from the angles illustrated in FIG. 3 there are only two or three threads actually bearing upon each other due to the deformation of the members during the expansion. Even though there are only two or three threads engaged, they still must not shear or the expansion would result in a failure. It has been determined by the inventors hereof that the load flank must maintain at least about ½ engagement (e.g. 50% of thread height) of the threads that are engaged throughout the expansion process while thread width should be about 20-50% greater than thread height. The wicker 28 may be one or more wickers and in embodiments may be hardened. It is noted that hardened wickers for this component are contemplated because it is acceptable for the lock ring 20 to split during expansion since its functions are to hold the subsystems 14 and 16 and the seal 18 in place for run in and then to potentially assist in restricting longitudinal movement of the liner during expansion. It is known that when tubular members are expanded, they change in axial length and hence have a component of movement in the longitudinal direction. This kind of movement when setting slips causes one or more of the wickers to poorly

engage the complementary structure because they are moving longitudinally while moving radially into engagement. This is particularly true in an expansion situation using a swage because the radial expansion happens over time from one end of the tubular member to the other and hence the wickers brought into engagement first are only one or two, for example, and have relatively little longitudinal holding power. Those two will then slide longitudinally gouging the complementary structure (here the hanger) and have little load capacity. The restriction of liner longitudinal movement is desirable because it ensures that for slip subsystems **14** and **16**, all of the teeth (wickers) thereon will be fully engaged without a sliding movement rather than the first few wickers to engage sliding axially and thereby reducing their holding power. The lock ring **20** assists in this by reducing the longitudinal axial movement of the liner **12** since the wicker(s) **28** of the lock ring **20** engages the hanger prior to the slip subsystems engaging the hanger and thereby reduces potential longitudinal movement that might otherwise have occurred during expansion of the slip subsystem portions of the liner **12**.

**[0015]** In addition to the foregoing, the anchor **22** includes an anchor body **30** having an inside surface thread **32** and an outside surface wicker **34**. Thread **32** is another pre and post expansion engagement type thread similar to that of the lock ring **20**. The anchor differs in that the wicker(s) **34** are not hardened since the splitting of the anchor **22** during expansion is not permitted. Rather, the anchor must remain a sealed component after expansion. It will also be noted that relatively more wickers **34** are provided on anchor **22** than are provided on lock ring **20**. This is directly related to the deformation resistance of each wicker. Hardened wickers have substantially greater resistance to deformation relative to nonhardened wickers and accordingly fewer are needed to provide a desired amount of movement limitation.

**[0016]** In embodiments, it is contemplated that the lock ring **20** could be omitted by extending the length of the anchor to substitute for the lock ring **20** job of compressing the slip subsystems and seal for running.

**[0017]** During use, and referring to FIG. **4**, the system **10** is run in the borehole **40** into a parent casing **42** having a liner hanger **44**. The system **10** is easy to run because it has a reduced diameter. Once the system **10** reaches the hanger **44**, a swage **46** is run through the system **10** to expand the same thereby preparing the borehole **40** for further activities.

**[0018]** One of the benefits of the system **10** is that it allows the use of softer less expensive low alloy steel materials, for example, without burst and collapse rating reductions.

**[0019]** Referring to FIG. **5**, a borehole system **50** including the system **10** comprises a borehole **52** in a subsurface formation **54**. A casing **56** is disposed within the borehole **52**. And the liner system **10** is disposed within the casing **56**.

**[0020]** Set forth below are some embodiments of the foregoing disclosure:

**[0021]** Embodiment 1: A hanger system including an expandable liner, an expandable first slip subsystem disposed about the liner, an expandable second slip subsystem disposed about the liner, a seal disposed about the liner and between the first slip subsystem and the second slip subsystem, and an expandable lock ring disposed about the liner and against one of the first slip subsystem or the second slip subsystem.

**[0022]** Embodiment 2: The system as in any prior embodiment further comprising an expandable anchor having a wicker on an outside surface thereof.

**[0023]** Embodiment 3: The system as in any prior embodiment wherein the wicker is a plurality of wickers.

**[0024]** Embodiment 4: The system as in any prior embodiment wherein the wicker is unhardened.

**[0025]** Embodiment 5: The system as in any prior embodiment wherein the anchor includes a polished bore therein.

**[0026]** Embodiment 6: The system as in any prior embodiment wherein the lock ring compresses the first slip subsystem, second slip subsystem and seal against one another for run in.

**[0027]** Embodiment 7: The system as in any prior embodiment wherein the lock ring is disposed about the liner adjacent one of the first slip subsystem and the second slip subsystem.

**[0028]** Embodiment 8: The system as in any prior embodiment wherein the lock ring includes a wicker on an exterior surface thereof.

**[0029]** Embodiment 9: The system as in any prior embodiment wherein the wicker is a plurality of wickers.

**[0030]** Embodiment 10: The system as in any prior embodiment wherein the wicker is hardened.

**[0031]** Embodiment 11: A method for lining a borehole including running a liner system as in any prior embodiment into a borehole, landing the liner system in a liner hanger, expanding the first slip subsystem simultaneously with a portion of the liner, expanding the second slip subsystem simultaneously with another portion of the liner, and sealing the liner to the liner hanger between the first slip subsystem and the second slip subsystem with the seal.

**[0032]** Embodiment 12: The method as in any prior embodiment further comprising expanding an anchor of the liner system.

**[0033]** Embodiment 13: The method as in any prior embodiment wherein the expanding is by swaging.

**[0034]** Embodiment 14: The method as in any prior embodiment wherein wickers of the anchor are driven into a parent casing.

**[0035]** Embodiment 15: The method as in any prior embodiment wherein the wickers of the anchor arrest longitudinal movement of the liner while expanding thereby causing the first and second slip subsystems to set without axial movement relative to the hanger.

**[0036]** Embodiment 16: The method as in any prior embodiment wherein the anchor is expanded without splitting thereof.

**[0037]** Embodiment 17: The method as in any prior embodiment further comprising expanding the lock ring simultaneously with another portion of the liner.

**[0038]** Embodiment 18: The method as in any prior embodiment further including splitting the lock ring due to expansion thereof.

**[0039]** Embodiment 19: The method as in any prior embodiment further comprising driving a wicker on an exterior surface of the lock ring into the hanger to arrest longitudinal movement of the liner relative to the hanger.

**[0040]** Embodiment 20: A borehole system including a borehole in a subsurface formation, a casing in the borehole, and a liner system as in any prior embodiment disposed within the casing.

**[0041]** The use of the terms “a” and “an” and “the” and similar referents in the context of describing the invention

(especially in the context of the following claims) are to be construed to cover both the singular and the plural, unless otherwise indicated herein or clearly contradicted by context. Further, it should be noted that the terms “first,” “second,” and the like herein do not denote any order, quantity, or importance, but rather are used to distinguish one element from another. The terms “about”, “substantially” and “generally” are intended to include the degree of error associated with measurement of the particular quantity based upon the equipment available at the time of filing the application. For example, “about” and/or “substantially” and/or “generally” can include a range of  $\pm 8\%$  or  $5\%$ , or  $2\%$  of a given value.

**[0042]** The teachings of the present disclosure may be used in a variety of well operations. These operations may involve using one or more treatment agents to treat a formation, the fluids resident in a formation, a borehole, and/or equipment in the borehole, such as production tubing. The treatment agents may be in the form of liquids, gases, solids, semi-solids, and mixtures thereof. Illustrative treatment agents include, but are not limited to, fracturing fluids, acids, steam, water, brine, anti-corrosion agents, cement, permeability modifiers, drilling muds, emulsifiers, demulsifiers, tracers, flow improvers etc. Illustrative well operations include, but are not limited to, hydraulic fracturing, stimulation, tracer injection, cleaning, acidizing, steam injection, water flooding, cementing, etc.

**[0043]** While the invention has been described with reference to an exemplary embodiment or embodiments, it will be understood by those skilled in the art that various changes may be made and equivalents may be substituted for elements thereof without departing from the scope of the invention. In addition, many modifications may be made to adapt a particular situation or material to the teachings of the invention without departing from the essential scope thereof. Therefore, it is intended that the invention not be limited to the particular embodiment disclosed as the best mode contemplated for carrying out this invention, but that the invention will include all embodiments falling within the scope of the claims. Also, in the drawings and the description, there have been disclosed exemplary embodiments of the invention and, although specific terms may have been employed, they are unless otherwise stated used in a generic and descriptive sense only and not for purposes of limitation, the scope of the invention therefore not being so limited.

1. A liner hanger system comprising:
  - an expandable liner;
  - an expandable first slip subsystem disposed about the liner;
  - an expandable second slip subsystem disposed about the liner;
  - a seal disposed about the liner and between the first slip subsystem and the second slip subsystem; and
  - an expandable lock ring disposed about the liner and against one of the first slip subsystem or the second slip subsystem, wherein the lock ring compresses the first slip subsystem, second slip subsystem and seal against one another for run in.

2. The system as claimed in claim 1 further comprising an expandable anchor having a wicker on an outside surface thereof.

3. The system as claimed in claim 2 wherein the wicker is a plurality of wickers.

4. The system as claimed in claim 2 wherein the wicker is unhardened.

5. The system as claimed in claim 2 wherein the anchor includes a polished bore therein.

6. (canceled)

7. The system as claimed in claim 1 wherein the lock ring is disposed about the liner adjacent one of the first slip subsystem and the second slip subsystem.

8. The system as claimed in claim 1 wherein the lock ring includes a wicker on an exterior surface thereof.

9. The system as claimed in claim 8 wherein the wicker is a plurality of wickers.

10. The system as claimed in claim 8 wherein the wicker is hardened.

11. A method for lining a borehole comprising:

- running a liner hanger system as claimed in claim 1 into a borehole;

- landing the liner hanger system in the borehole;

- expanding the first slip subsystem simultaneously with a portion of the liner;

- expanding the second slip subsystem simultaneously with another portion of the liner; and

- sealing the liner to the liner hanger between the first slip subsystem and the second slip subsystem with the seal.

12. The method as claimed in claim 11 further comprising expanding an anchor of the liner system.

13. The method as claimed in claim 12 wherein the expanding is by swaging.

14. The method as claimed in claim 12 wherein wickers of the anchor are driven into a parent casing.

15. The method as claimed in claim 11 wherein the wickers of the anchor arrest longitudinal movement of the liner while expanding thereby causing the first and second slip subsystems to set without axial movement relative to the hanger.

16. The method as claimed in claim 12 wherein the anchor is expanded without splitting thereof.

17. The method as claimed in claim 11 further comprising expanding the lock ring simultaneously with another portion of the liner.

18. The method as claimed in claim 17 further including splitting the lock ring due to expansion thereof.

19. The method as claimed in claim 17 further comprising driving a wicker on an exterior surface of the lock ring into the hanger to arrest longitudinal movement of the liner relative to the hanger.

20. A borehole system comprising:

- a borehole in a subsurface formation;

- a casing in the borehole; and

- a liner hanger system as claimed in claim 1 disposed within the casing.

\* \* \* \* \*