

(12) **United States Patent**
Bestic et al.

(10) **Patent No.:** **US 11,781,894 B2**
(45) **Date of Patent:** ***Oct. 10, 2023**

(54) **FLUID MONITORING MODULE ARRANGEMENTS**

- (71) Applicant: **Swagelok Company**, Solon, OH (US)
- (72) Inventors: **Michael D. Bestic**, Sagamore Hills, OH (US); **David J. Hasak**, Concord, OH (US); **Bryan S. Reiger**, Willowick, OH (US); **Andrew Creque**, Macedonia, OH (US); **Marius O. Stroescu**, Mayfield Hts., OH (US); **William Michael Ponikvar**, Sagamore Hills, OH (US); **Cal R. Brown**, Lyndhurst, OH (US); **Matthew R. Dixon**, Parma, OH (US); **Joshua Webb**, Stow, OH (US); **Theodore J. Gausman**, Lyndhurst, OH (US); **Michael Whisler**, Southington, OH (US); **Randy Ricken**, Littleton, CO (US); **Robert Bianco**, Columbia Station, OH (US); **Andrew P. Marshall**, University Heights, OH (US)

- (73) Assignee: **Swagelok Company**, Solon, OH (US)
- (*) Notice: Subject to any disclaimer, the term of this patent is extended or adjusted under 35 U.S.C. 154(b) by 250 days.
This patent is subject to a terminal disclaimer.

(21) Appl. No.: **17/124,968**
(22) Filed: **Dec. 17, 2020**

(65) **Prior Publication Data**
US 2021/0102826 A1 Apr. 8, 2021

Related U.S. Application Data
(63) Continuation of application No. 16/573,289, filed on Sep. 17, 2019, now Pat. No. 10,890,474.
(Continued)

- (51) **Int. Cl.**
G01F 1/88 (2006.01)
G01F 1/40 (2006.01)
(Continued)
- (52) **U.S. Cl.**
CPC **G01F 1/88** (2013.01); **G01F 1/363** (2013.01); **G01F 1/40** (2013.01); **G08C 17/02** (2013.01)
- (58) **Field of Classification Search**
None
See application file for complete search history.

- (56) **References Cited**
U.S. PATENT DOCUMENTS
- | | | |
|-------------|--------|-----------|
| 4,153,083 A | 5/1979 | Imler |
| 4,576,204 A | 3/1986 | Smallhorn |
- (Continued)
- FOREIGN PATENT DOCUMENTS
- | | | |
|----|-----------|--------|
| CN | 203117796 | 8/2013 |
| EP | 1369672 | 7/2009 |
- (Continued)

OTHER PUBLICATIONS
International Search Report and Written Opinion from PCT/US2019/051375 dated Jan. 27, 2020.
(Continued)

Primary Examiner — Harshad R Patel
(74) *Attorney, Agent, or Firm* — Calfee, Halter & Griswold LLP

(57) **ABSTRACT**
A flow sensing device includes a first body member defining an inlet port, an upstream sensor port, and a first connecting port; a second body member defining an outlet port, a downstream sensor port, and a second connecting port; a flow restricting element defining a flow restricting passage and including a first end connection coupled to the first connecting port and a second end connection coupled to the

(Continued)

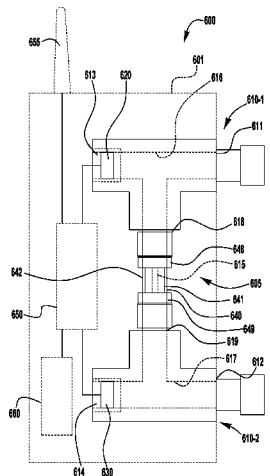

second connecting port, such that the flow restricting passage is disposed between the inlet port and the outlet port, and between the upstream sensor port and the downstream sensor port; a first fluid sensor assembled with the upstream sensor port; and a second fluid sensor assembled with the downstream sensor port.

19 Claims, 33 Drawing Sheets

Related U.S. Application Data

- (60) Provisional application No. 62/895,115, filed on Sep. 3, 2019, provisional application No. 62/844,399, filed on May 7, 2019, provisional application No. 62/844,390, filed on May 7, 2019, provisional application No. 62/844,383, filed on May 7, 2019, provisional application No. 62/775,066, filed on Dec. 4, 2018, provisional application No. 62/732,848, filed on Sep. 18, 2018.
- (51) **Int. Cl.**
G01F 1/36 (2006.01)
G08C 17/02 (2006.01)

References Cited

U.S. PATENT DOCUMENTS

| | | | |
|----------------|---------|------------------|-------------------------|
| 4,930,357 A | 6/1990 | Thurston | |
| 5,088,774 A * | 2/1992 | Spiegelman | F16L 39/005 285/332 |
| 5,174,765 A | 12/1992 | Williams | |
| 5,295,790 A | 3/1994 | Bossart | |
| 5,303,731 A | 4/1994 | Vavra | |
| 5,361,676 A | 11/1994 | Gibbs | |
| 5,415,065 A * | 5/1995 | McMills | B25B 23/141 81/124.2 |
| 5,454,945 A | 10/1995 | Spearman | |
| 5,469,749 A | 11/1995 | Shimada | |
| 5,535,633 A | 7/1996 | Kofoed | |
| 5,576,498 A | 11/1996 | Shambayati | |
| 5,672,832 A | 9/1997 | Cucci | |
| 5,750,892 A | 5/1998 | Huang | |
| 5,893,354 A | 4/1999 | Detweiler | |
| 6,436,720 B1 | 8/2002 | Oberbeck | |
| 6,539,968 B1 * | 4/2003 | White | G05D 7/0635 138/44 |
| 6,561,010 B2 | 5/2003 | Wilson | |
| 6,609,431 B1 | 8/2003 | Fietsworth | |
| 6,843,139 B2 | 1/2005 | Schumacher | |
| 7,096,738 B2 | 8/2006 | Schumacher | |
| 7,447,599 B2 | 11/2008 | Ellender et al. | |
| 7,729,869 B2 | 6/2010 | Brown | |
| 7,740,024 B2 | 6/2010 | Brodeur | |
| 7,775,126 B2 | 8/2010 | Eckhardt | |

| | | | |
|-------------------|---------|-----------------|---------------------------|
| 7,784,361 B2 | 8/2010 | Wiedmann | |
| 7,891,256 B2 | 2/2011 | Ushigusa | |
| 7,942,069 B2 | 5/2011 | Peterson | |
| 8,006,572 B2 | 8/2011 | Igarashi | |
| 8,082,946 B2 | 12/2011 | Laverdiere | |
| 8,281,669 B2 | 10/2012 | Ertl | |
| 8,281,817 B2 | 10/2012 | Tinker | |
| 8,297,478 B2 | 10/2012 | Hughes | |
| 8,376,312 B2 | 2/2013 | Mudd | |
| 8,418,549 B2 | 4/2013 | Speldrich | |
| 8,656,772 B2 | 2/2014 | Qasimi | |
| 8,718,954 B2 | 5/2014 | vonBlumenthal | |
| 8,746,057 B2 | 6/2014 | Yasuda | |
| 8,826,731 B2 | 9/2014 | Speldrich | |
| 9,494,947 B2 | 11/2016 | Hirata | |
| 9,562,796 B2 | 2/2017 | Lull | |
| 9,683,429 B2 | 6/2017 | Mathiesen | |
| 9,752,486 B2 | 9/2017 | Yang | |
| 10,087,943 B2 | 10/2018 | Taketomi | |
| 2001/0032674 A1 | 10/2001 | Brunet | |
| 2002/0002425 A1 | 1/2002 | Dossey | |
| 2003/0061888 A1 | 4/2003 | Gould | |
| 2004/0083807 A1 | 5/2004 | Mudd | |
| 2004/0177703 A1 | 9/2004 | Schumacher | |
| 2006/0010989 A1 | 1/2006 | Clark | |
| 2006/0266128 A1 * | 11/2006 | Clark | A61M 5/16854 73/861.52 |
| 2007/0017303 A1 | 1/2007 | Fujiwara | |
| 2007/0151366 A1 | 7/2007 | McDonald | |
| 2008/0250854 A1 | 10/2008 | Ding | |
| 2009/0157040 A1 | 6/2009 | Jacobson | |
| 2009/0221986 A1 | 9/2009 | Wang | |
| 2009/0229377 A1 | 9/2009 | Ushigusa et al. | |
| 2013/0247995 A1 | 9/2013 | Erlich | |
| 2014/0116217 A1 | 5/2014 | Hashish et al. | |
| 2016/0076909 A1 | 3/2016 | Kicpera | |
| 2017/0060143 A1 | 3/2017 | Ding et al. | |
| 2017/0292864 A1 | 10/2017 | Zhang | |
| 2018/0246533 A1 | 8/2018 | Somani | |
| 2019/0321815 A1 | 10/2019 | Schmid | |

FOREIGN PATENT DOCUMENTS

| | | |
|----|------------|--------|
| EP | 980507 | 7/2011 |
| EP | 2703787 | 9/2015 |
| EP | 2787329 | 2/2017 |
| GB | 2150039 | 1/1988 |
| JP | 3244849 | 1/2002 |
| JP | 2004157719 | 6/2004 |
| KR | 1855746 | 6/2018 |
| WO | 2017049782 | 3/2017 |

OTHER PUBLICATIONS

International Search Report and Written Opinion from PCT/US2019/051618 dated Jan. 27, 2020.
 Communication from European Application No. 19779322.7 dated Jul. 21, 2022.

* cited by examiner

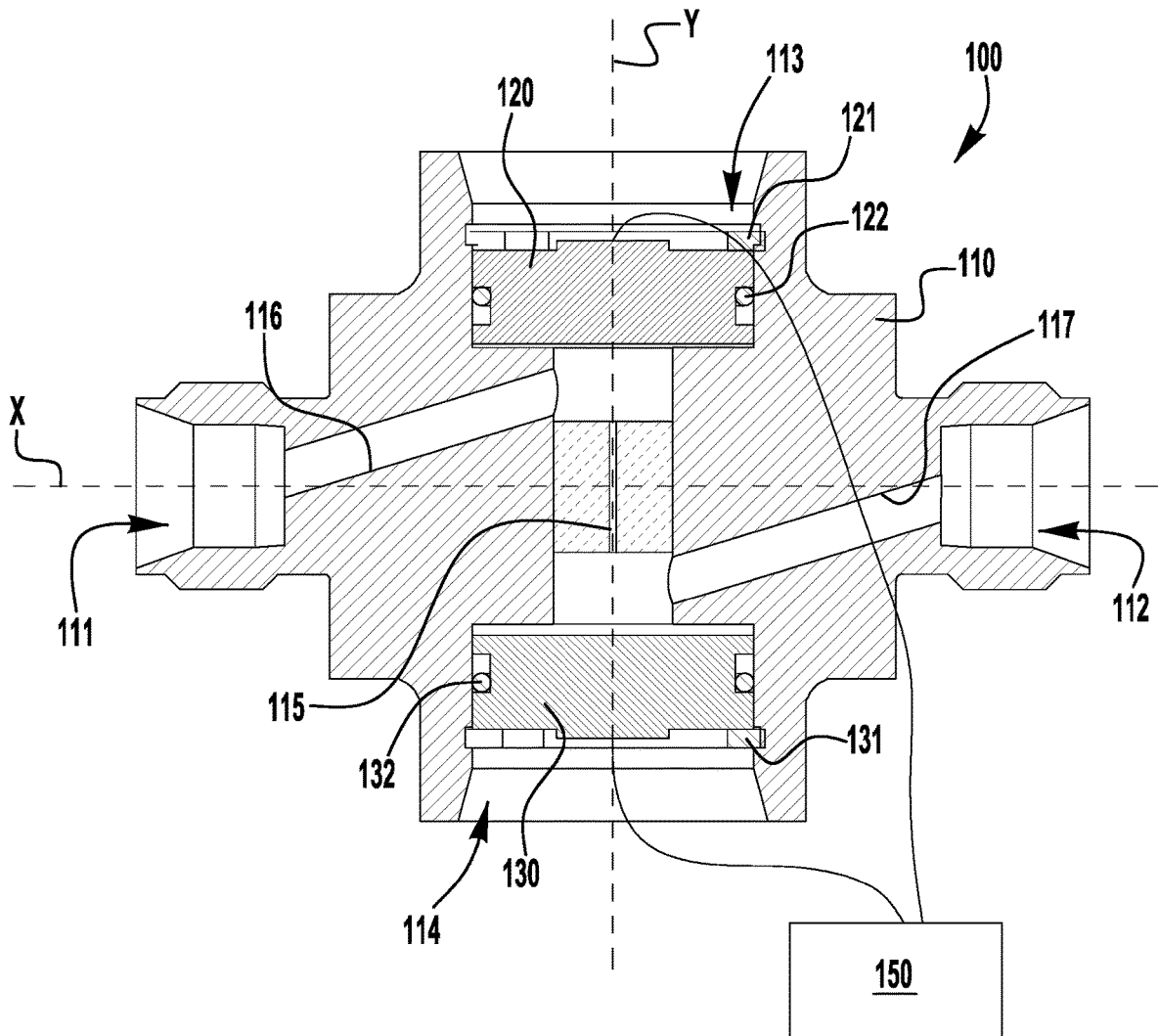

FIG. 1

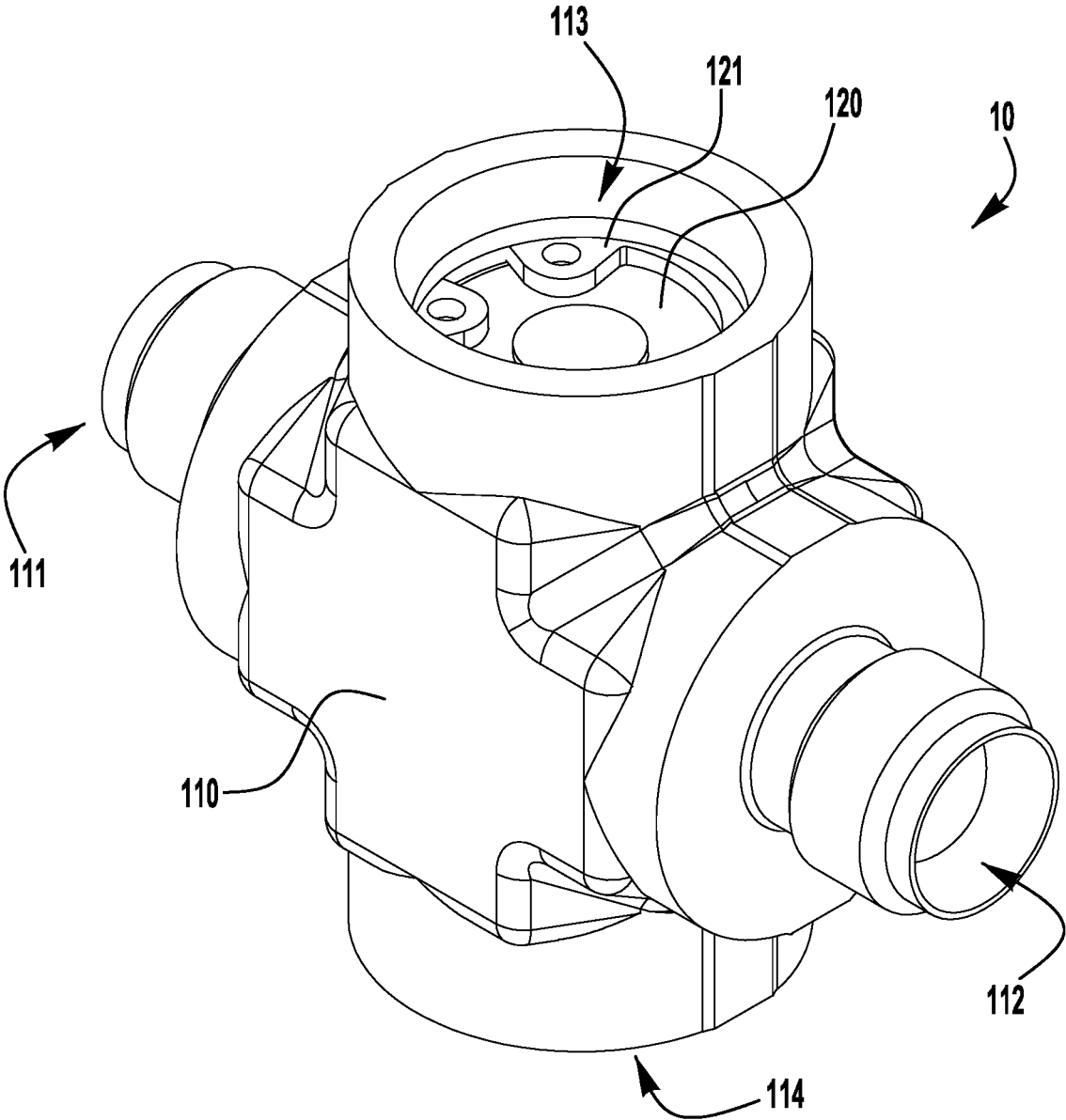

FIG. 1A

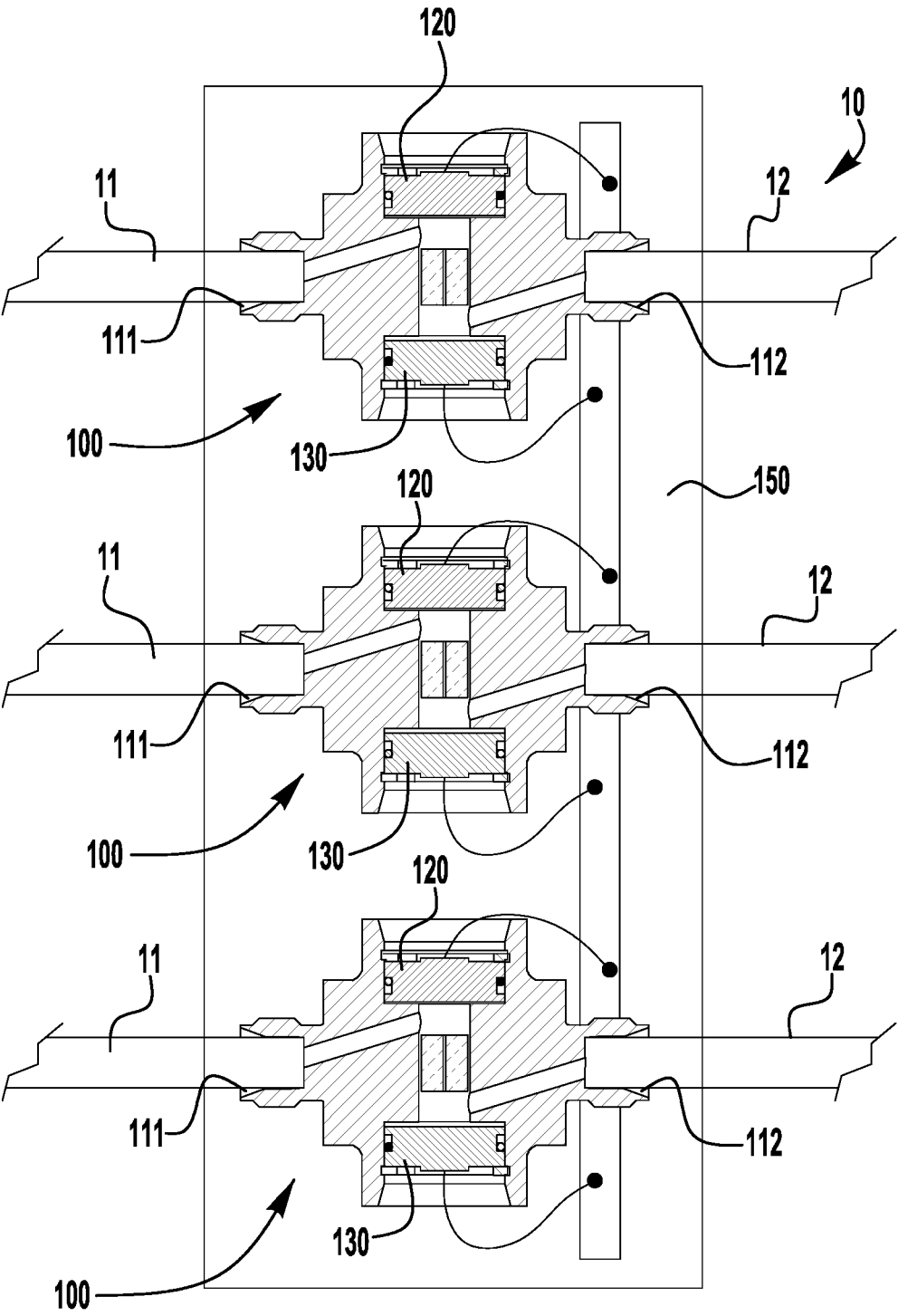

FIG. 1B

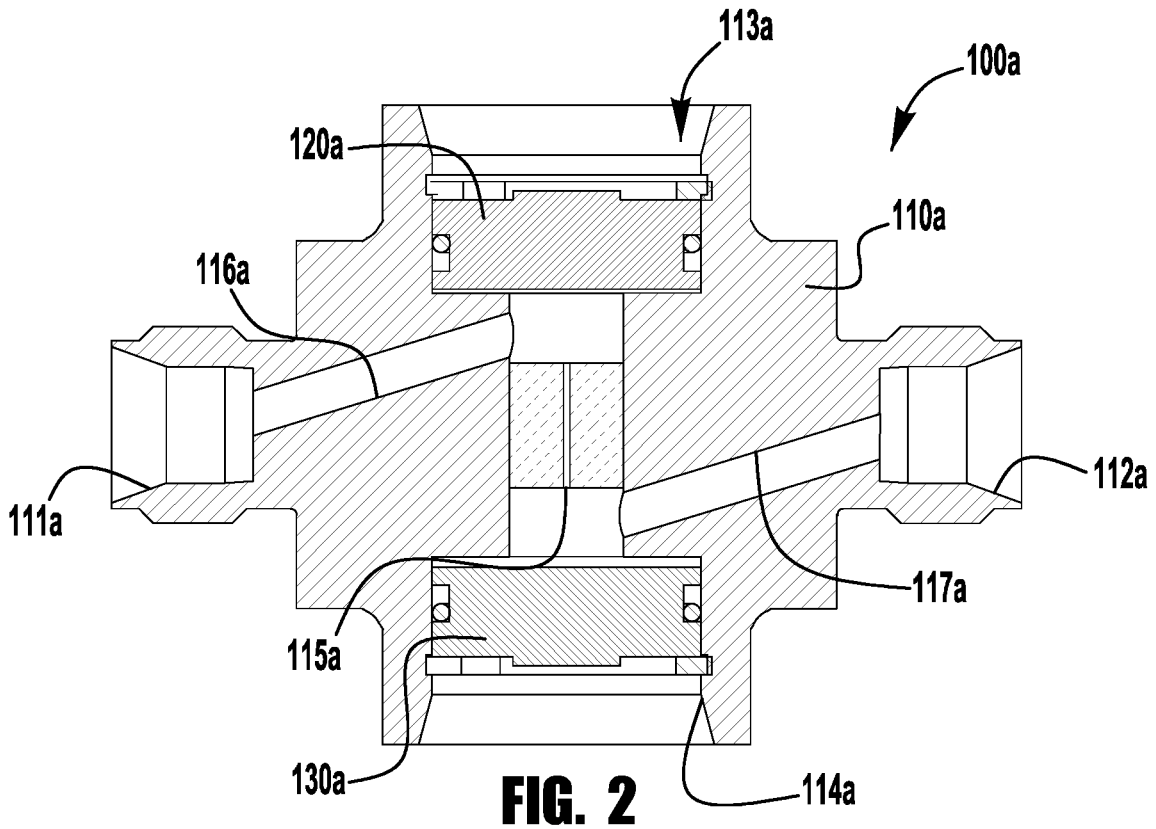

FIG. 2

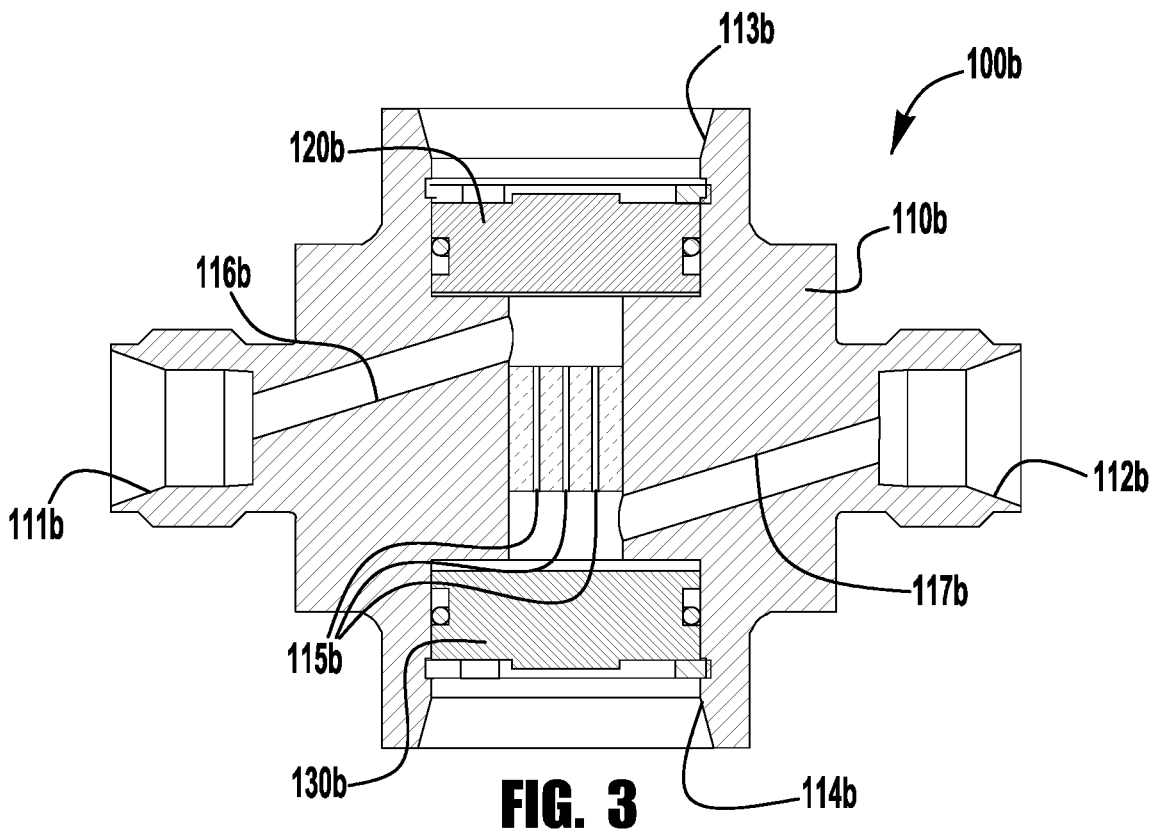

FIG. 3

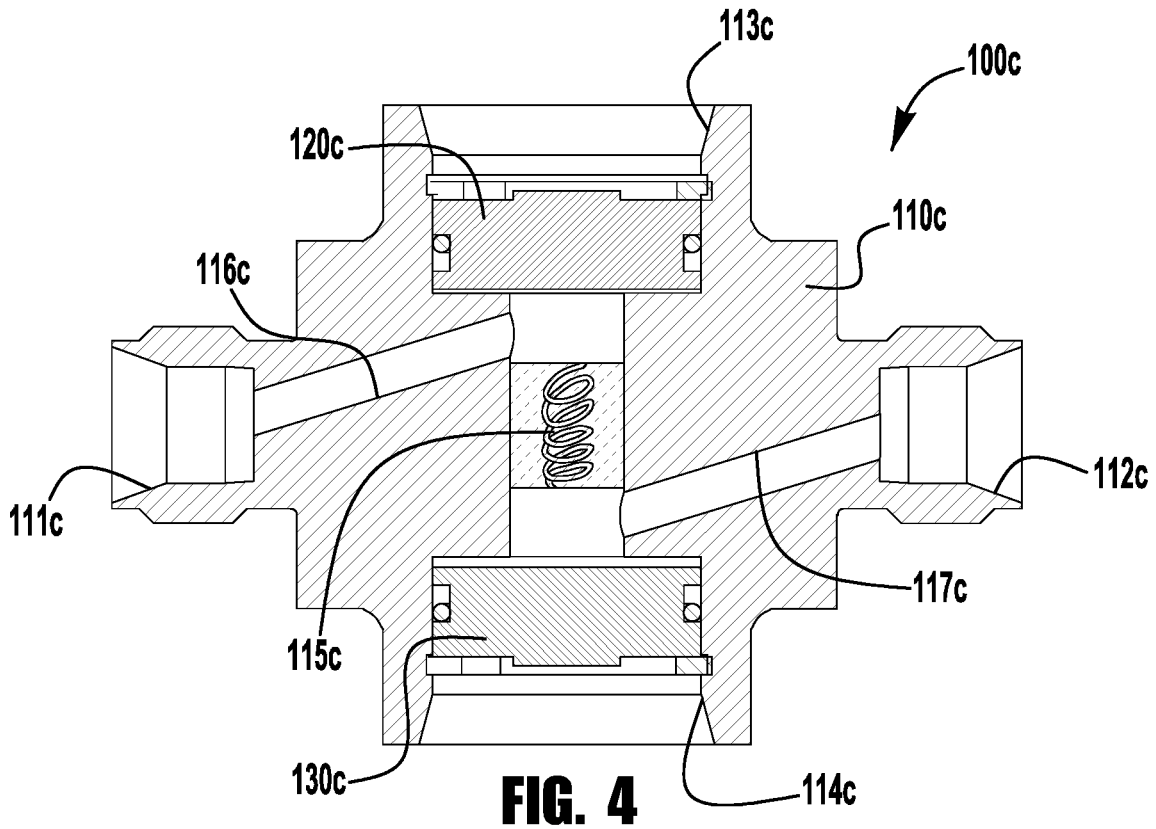

FIG. 4

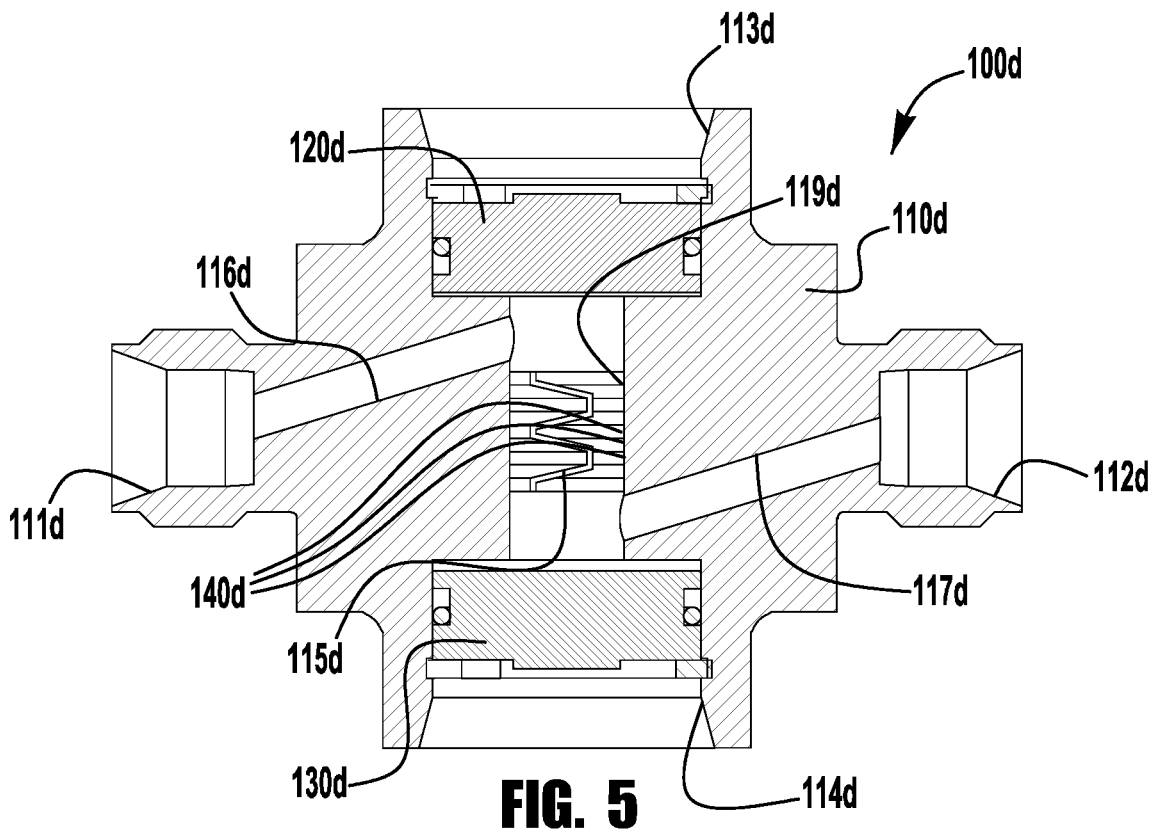
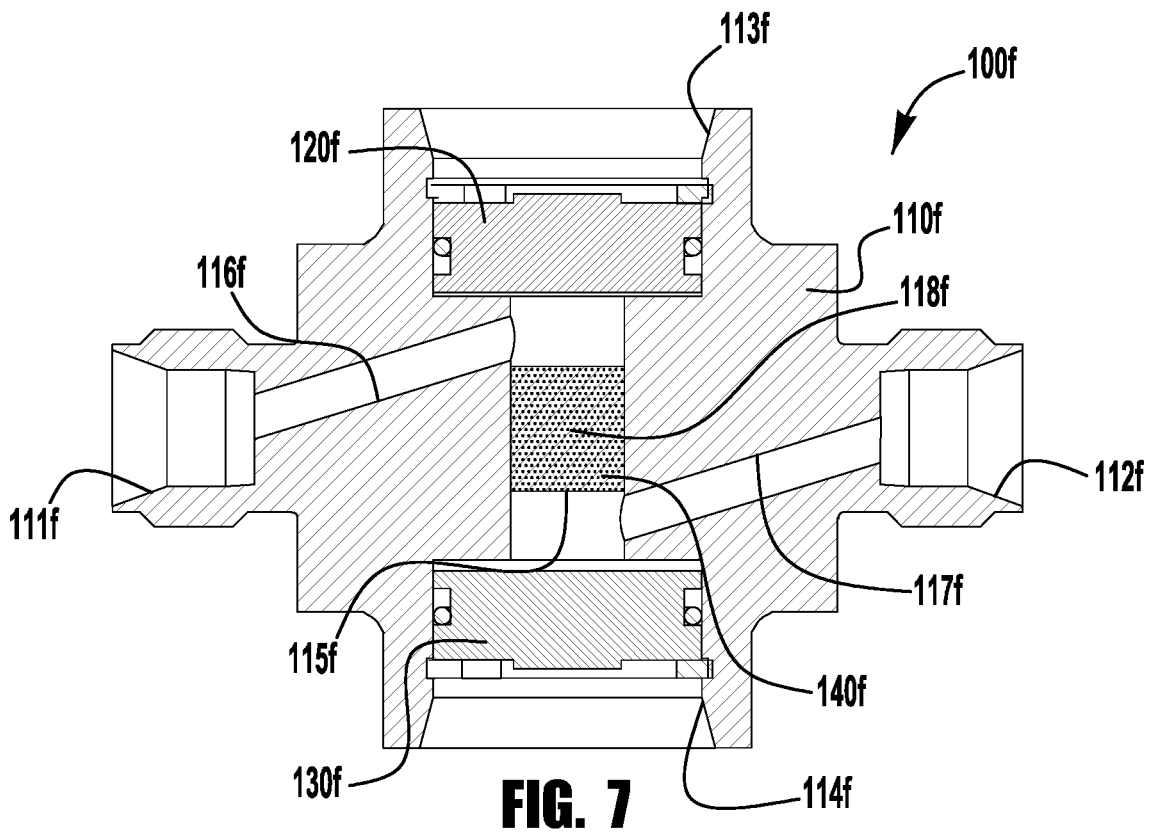
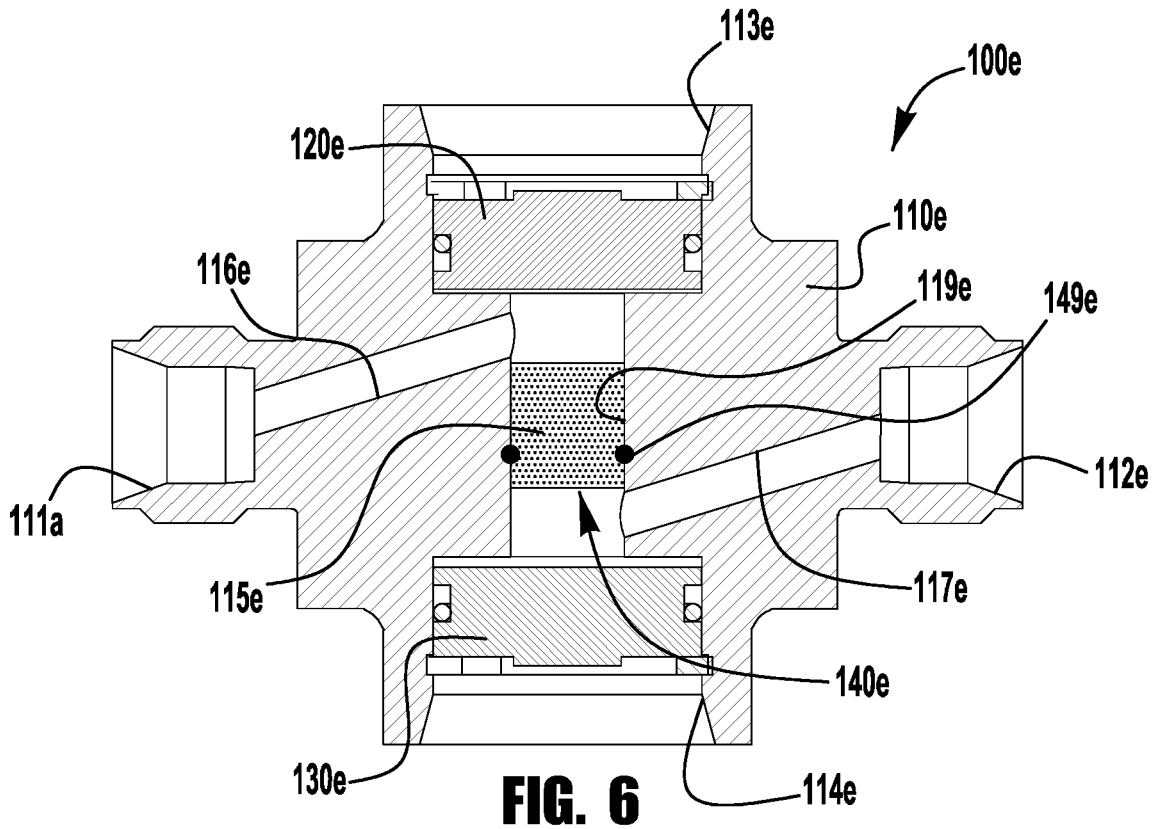

FIG. 5



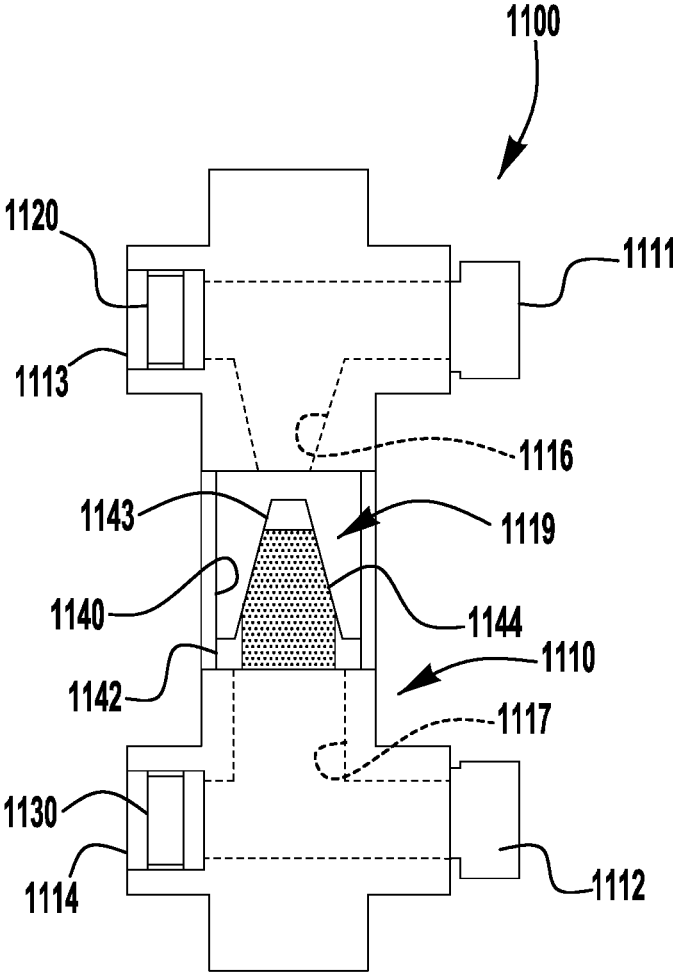

FIG. 8

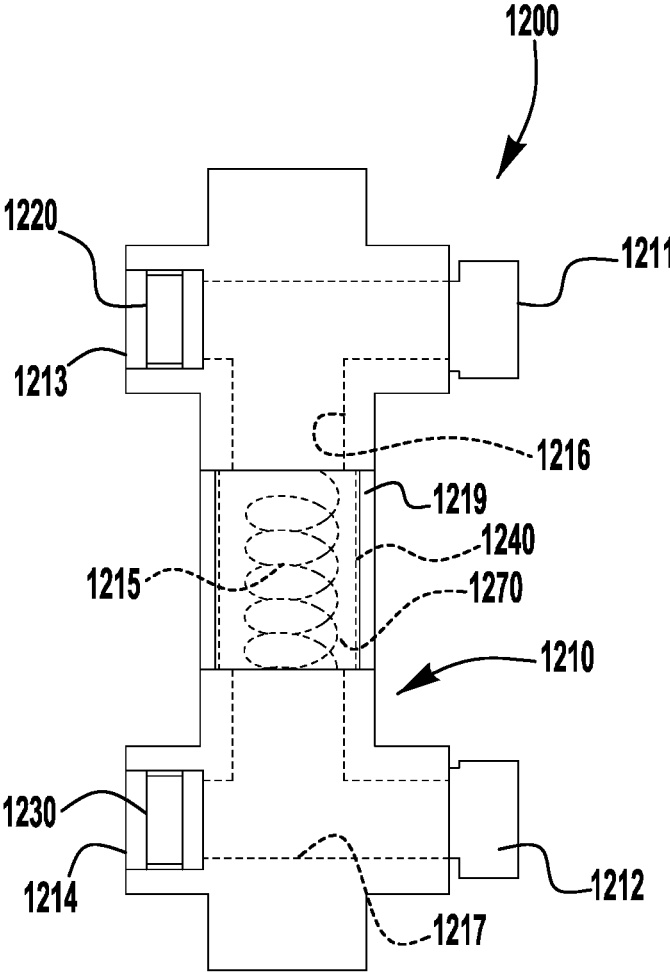

FIG. 9

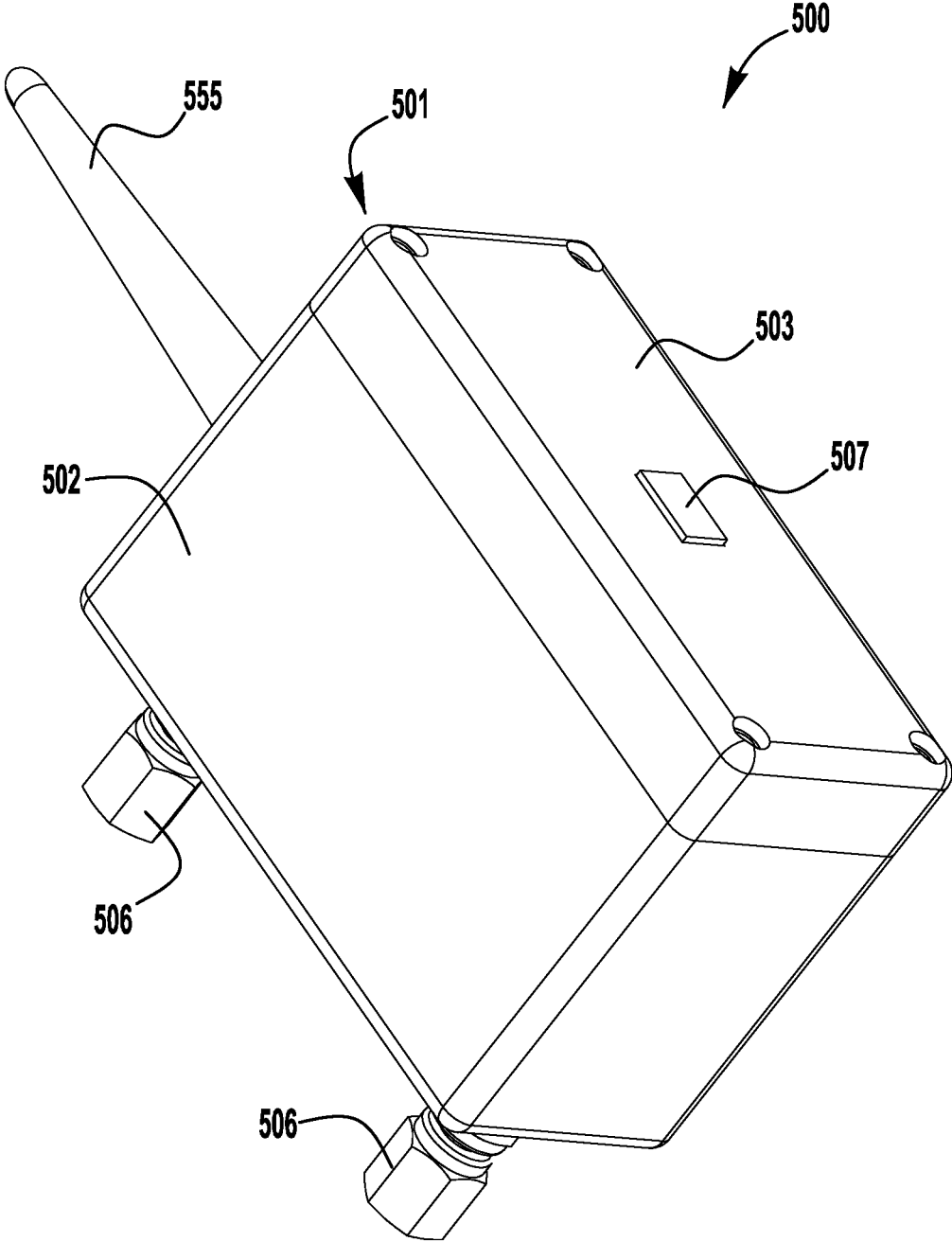

FIG. 10A

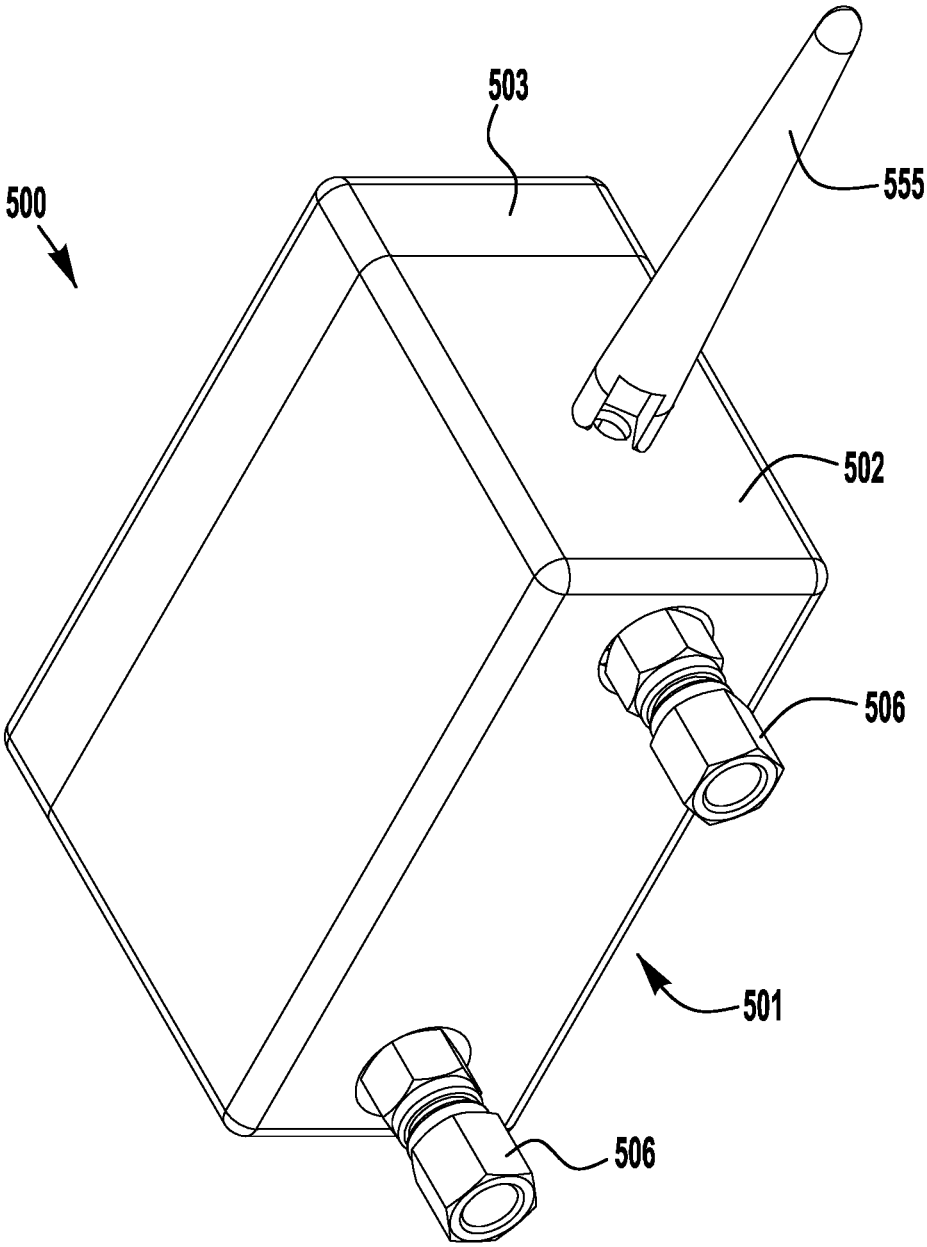

FIG. 10B

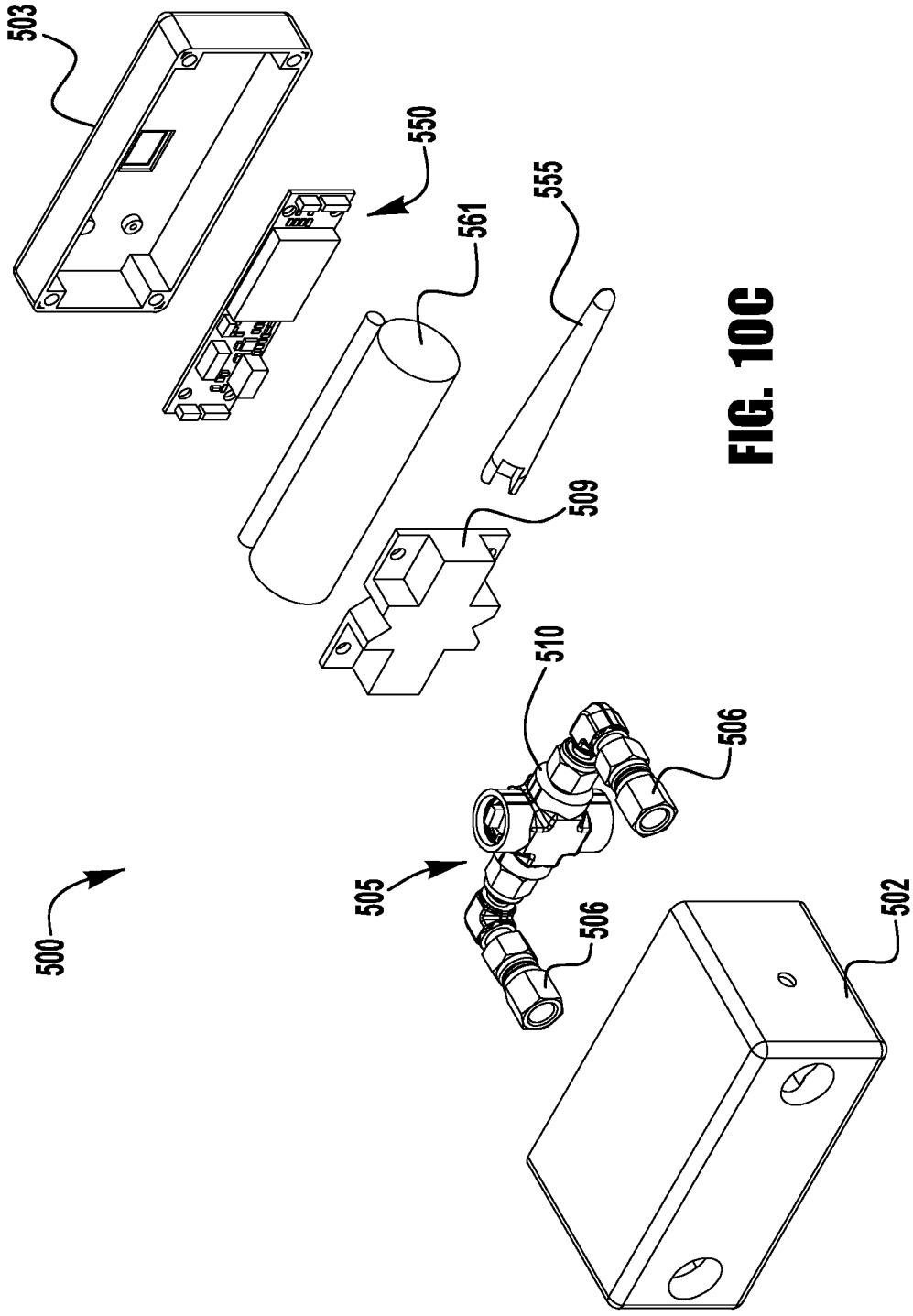

FIG. 10C

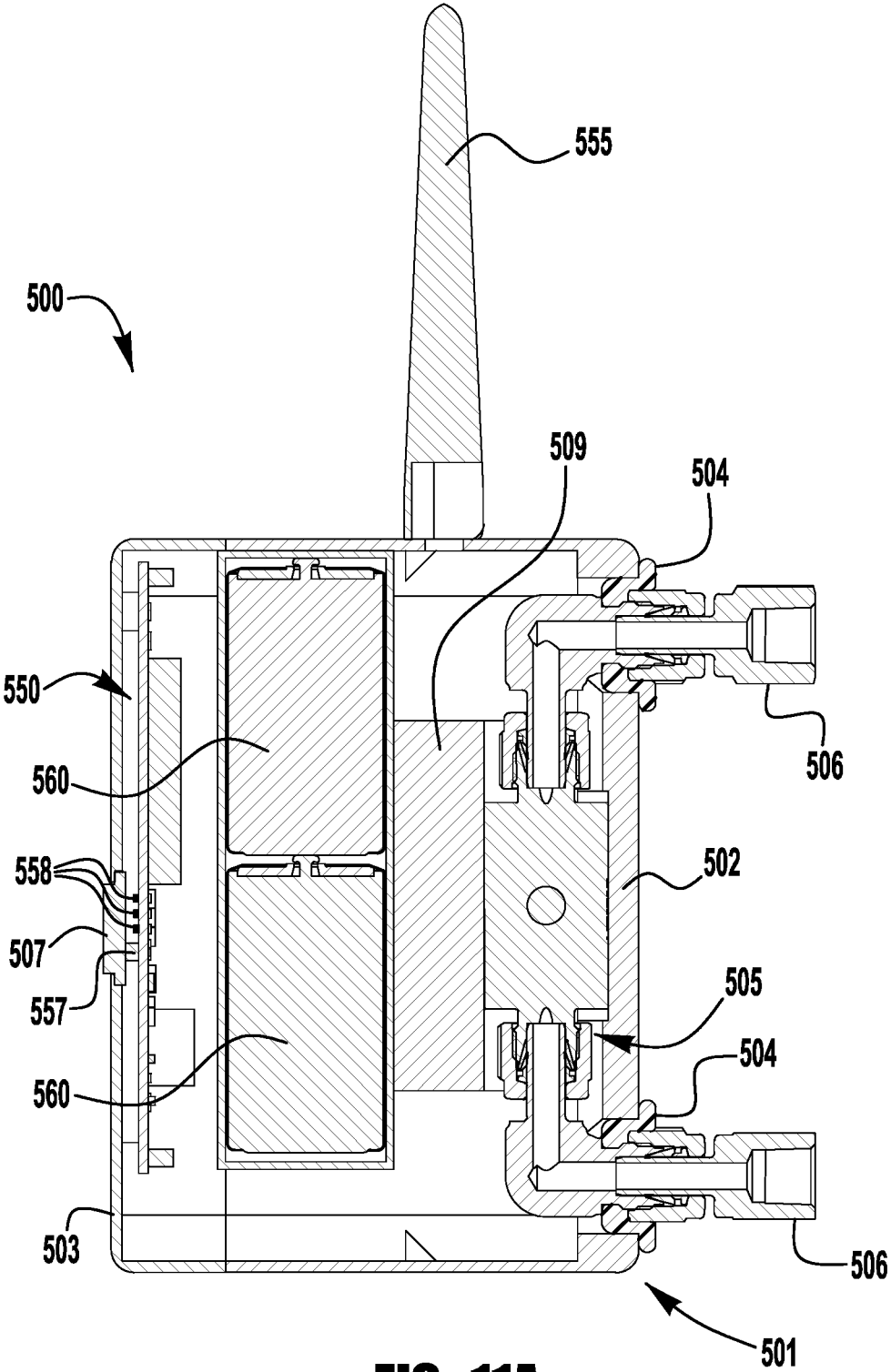

FIG. 11A

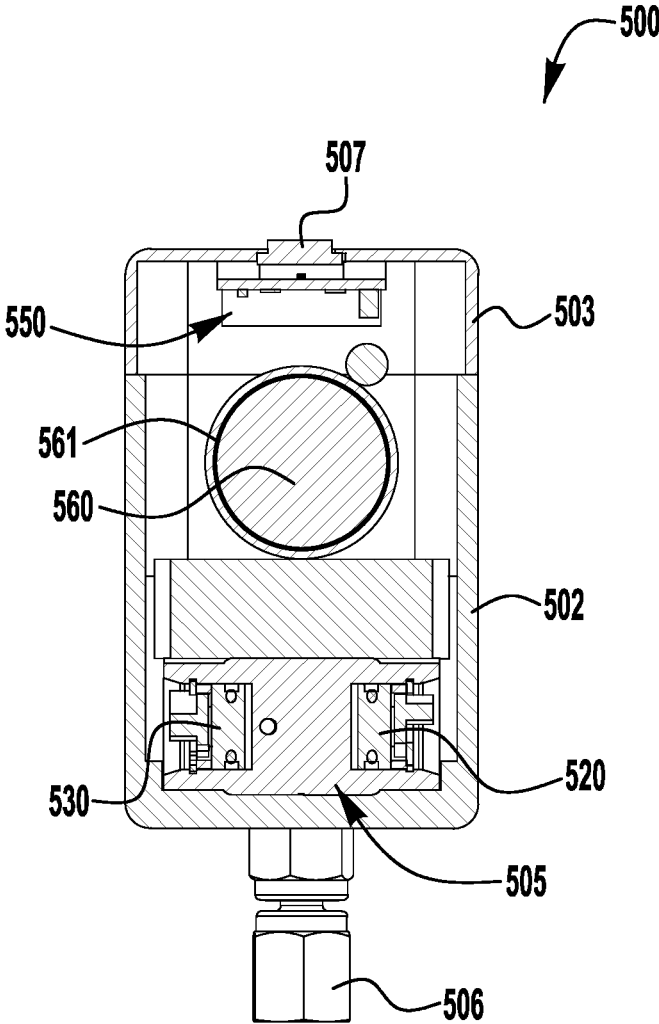

FIG. 11B

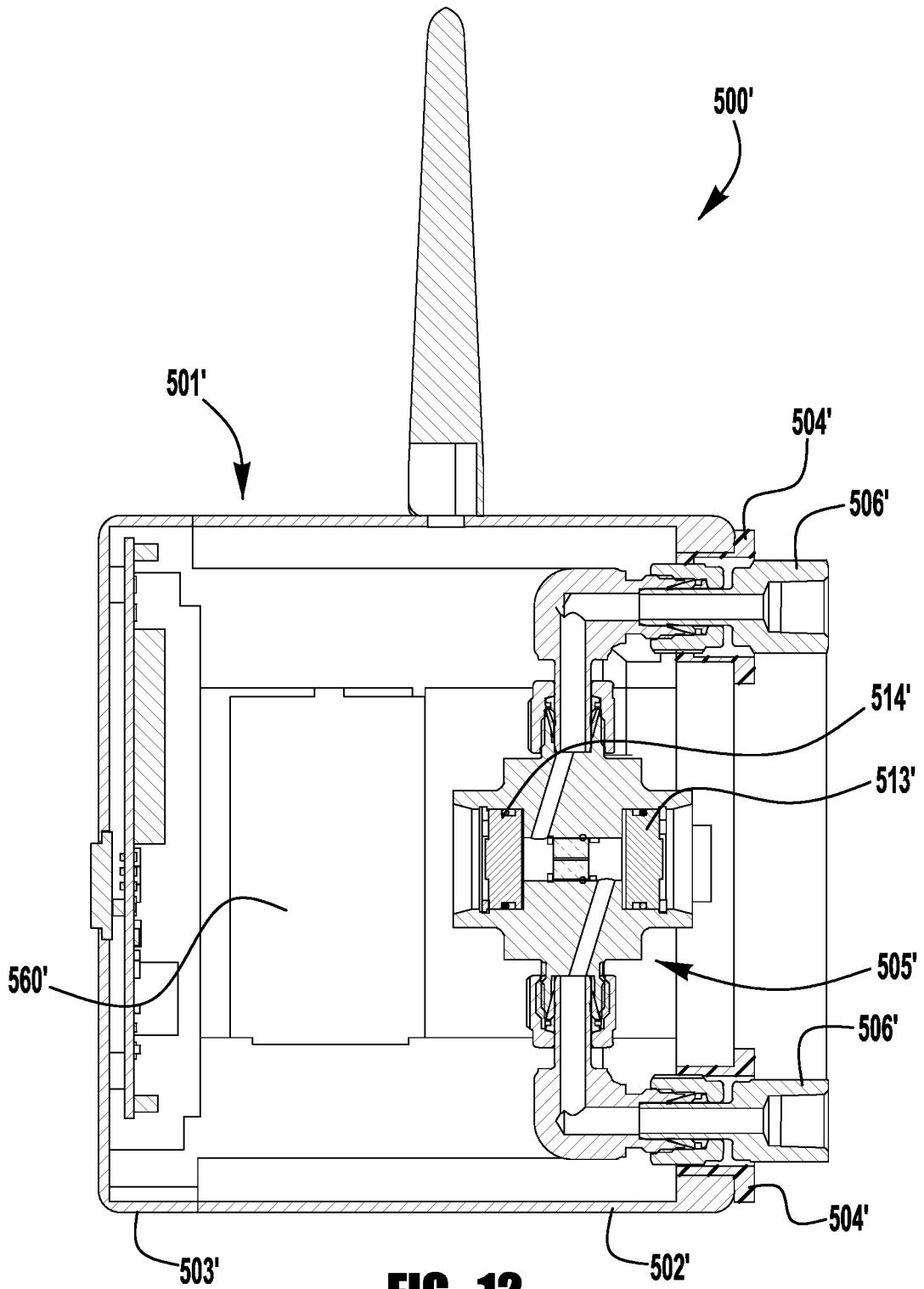

FIG. 12

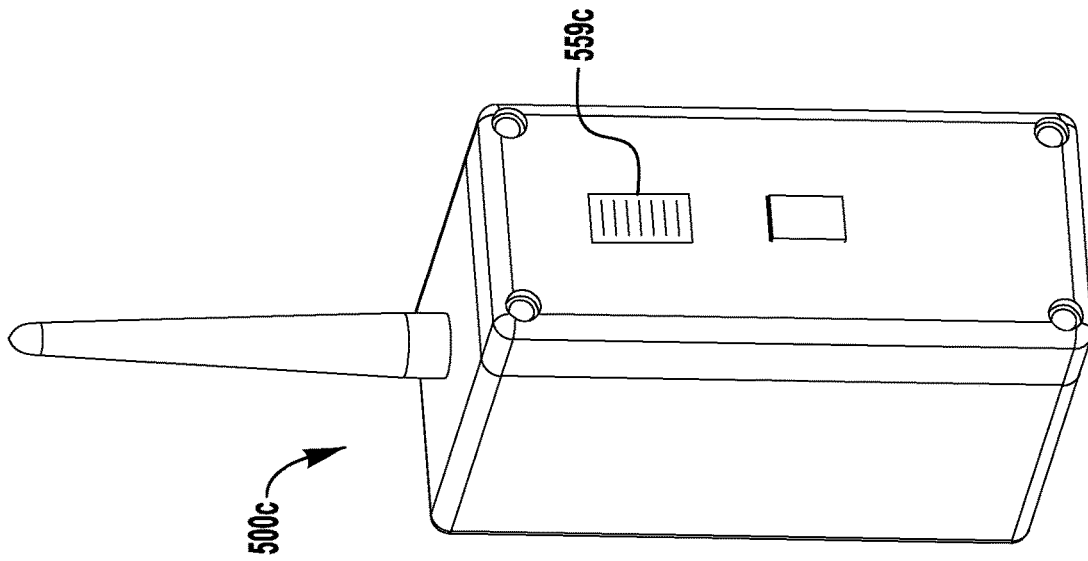

FIG. 13C

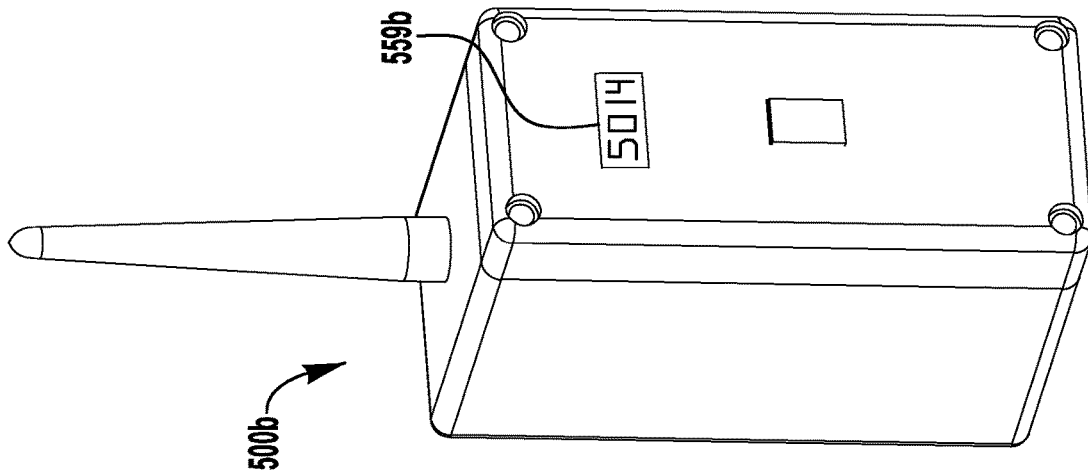

FIG. 13B

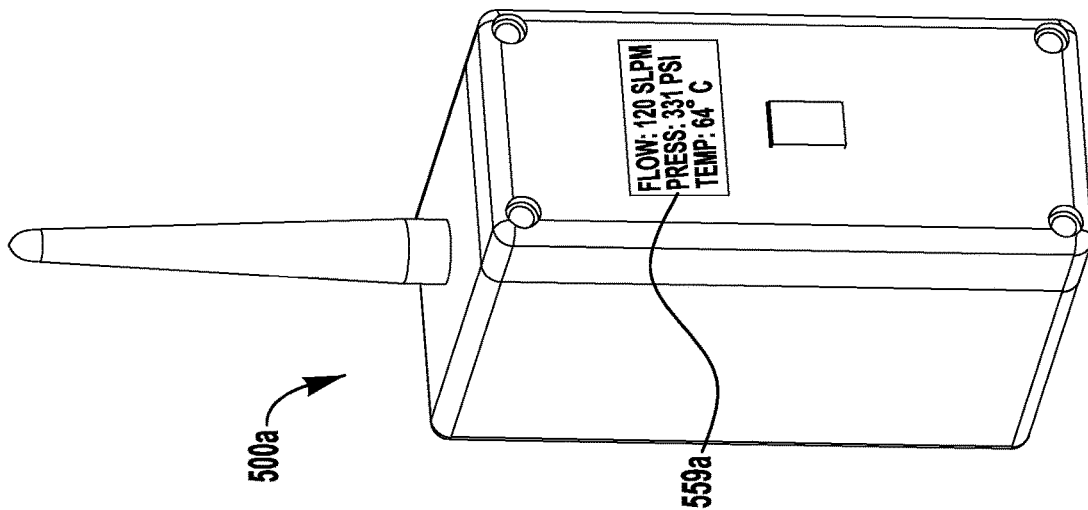

FIG. 13A

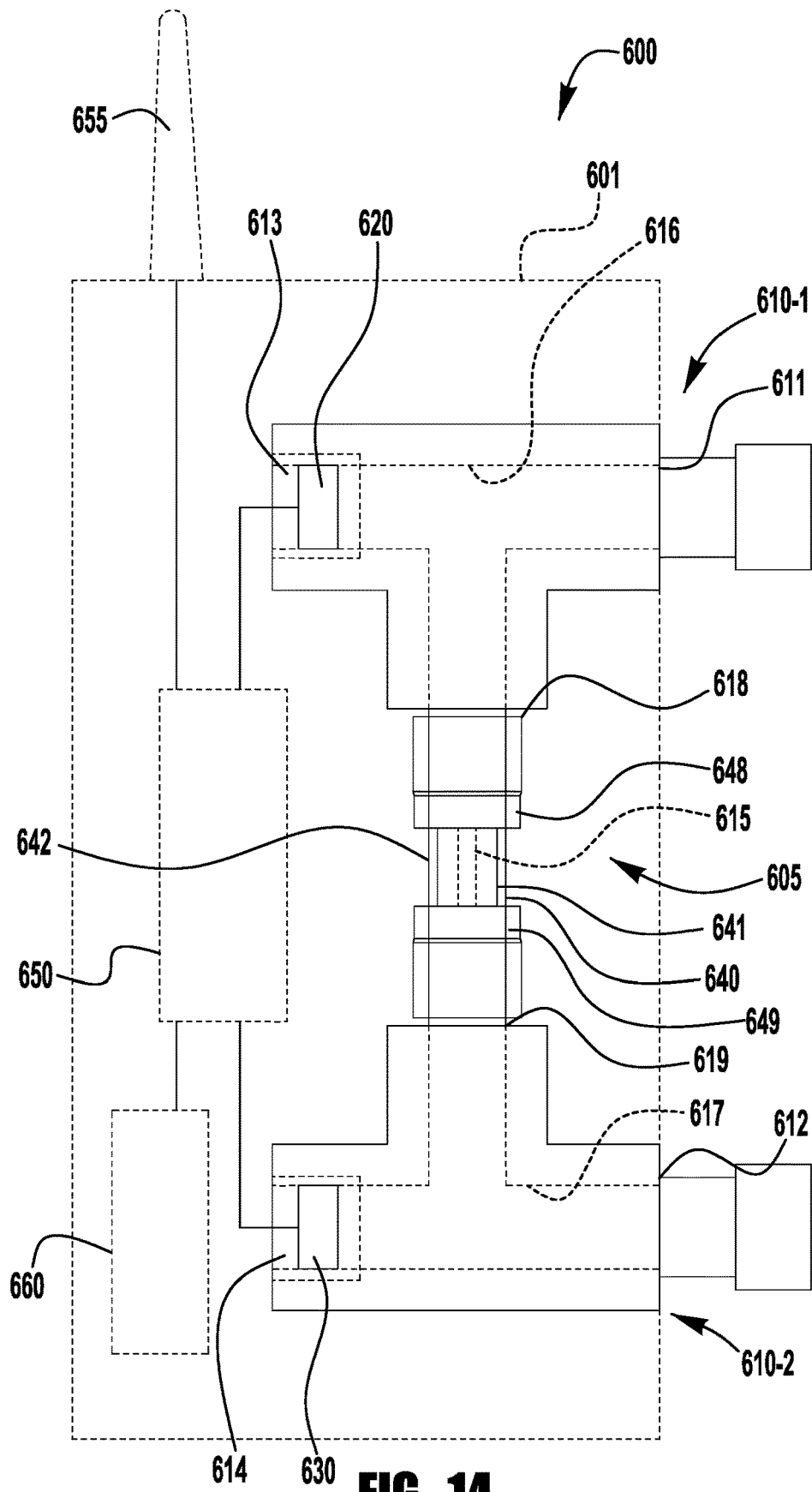

FIG. 14

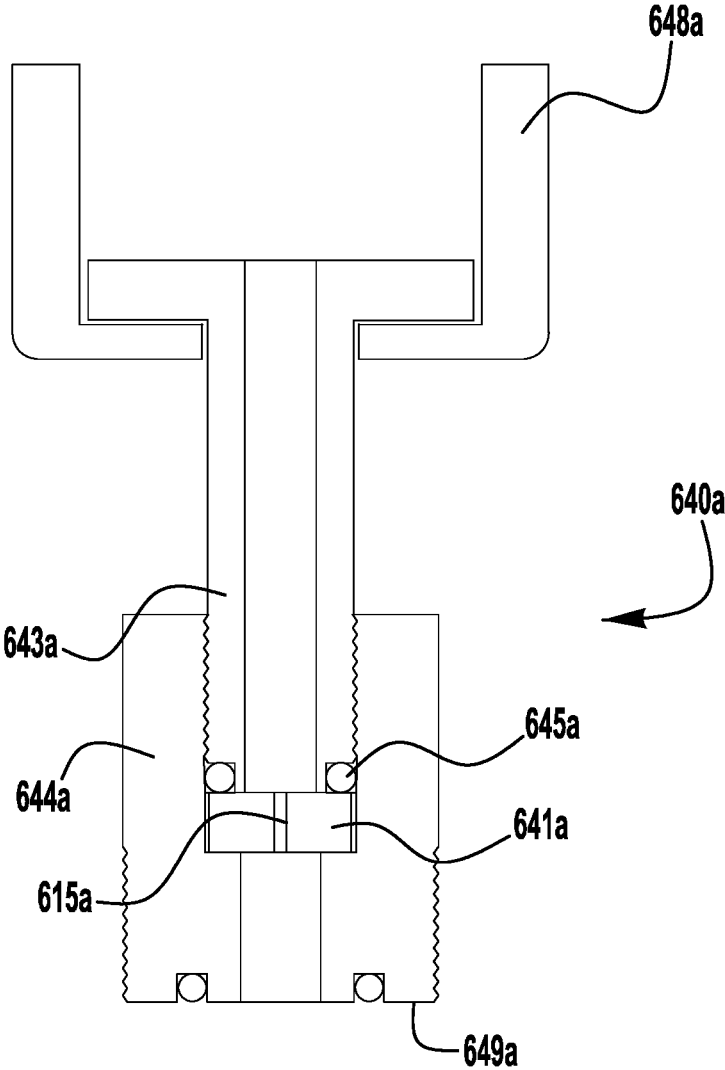

FIG. 14A

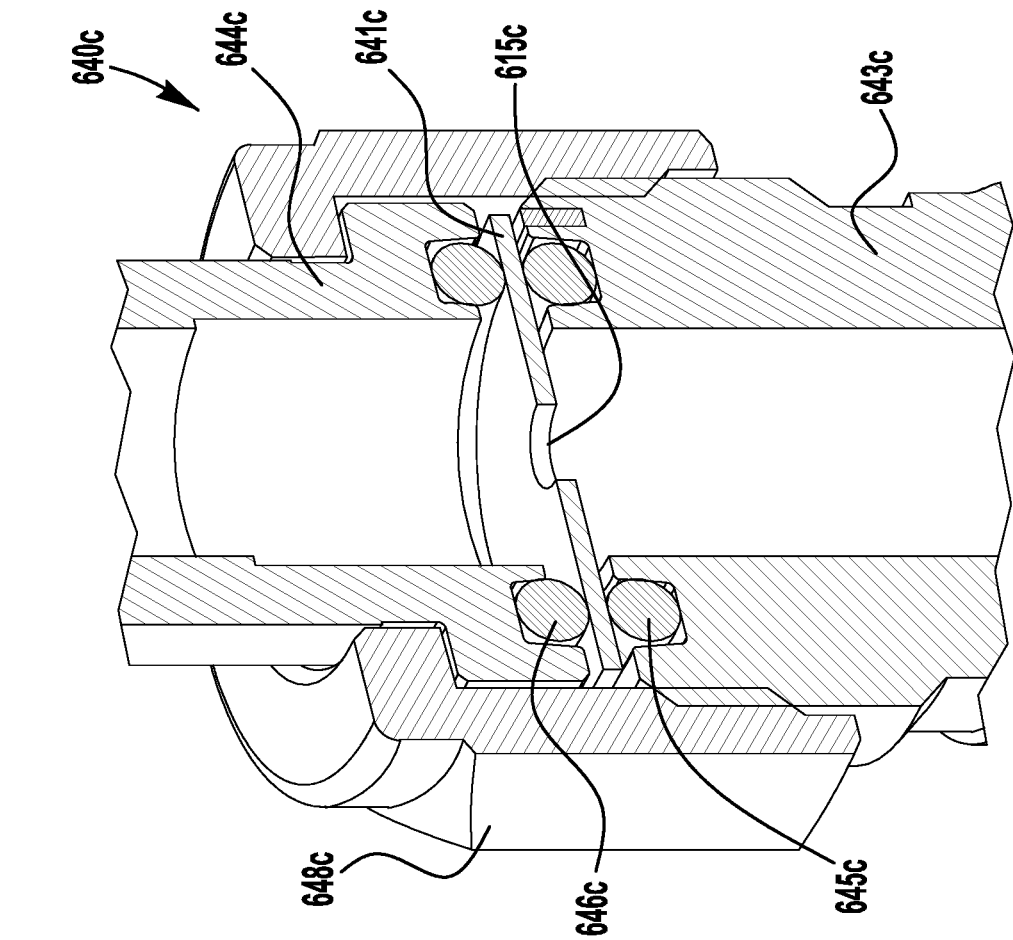

FIG. 14C

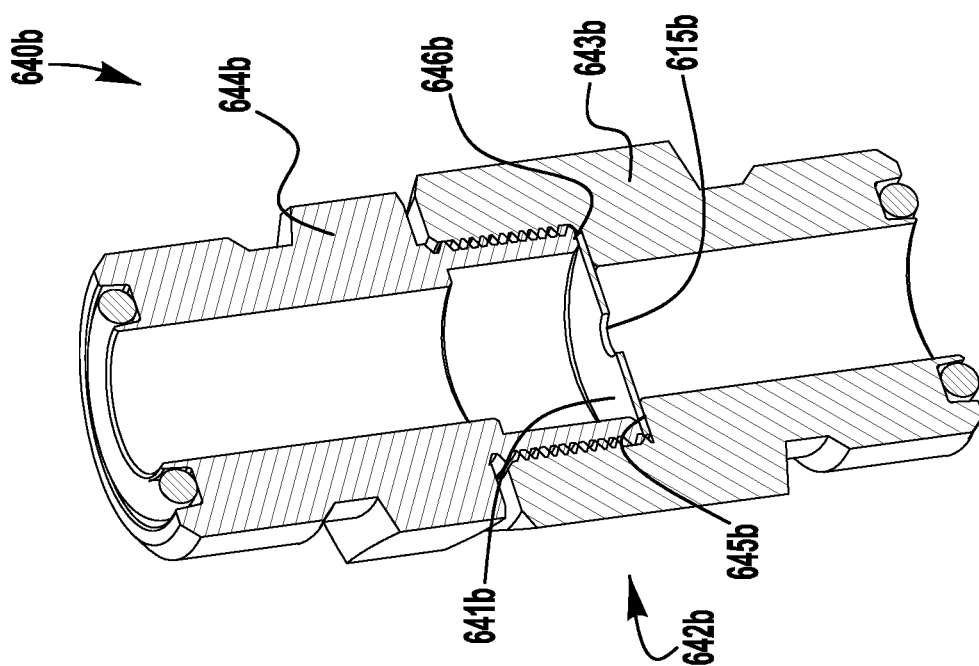

FIG. 14B

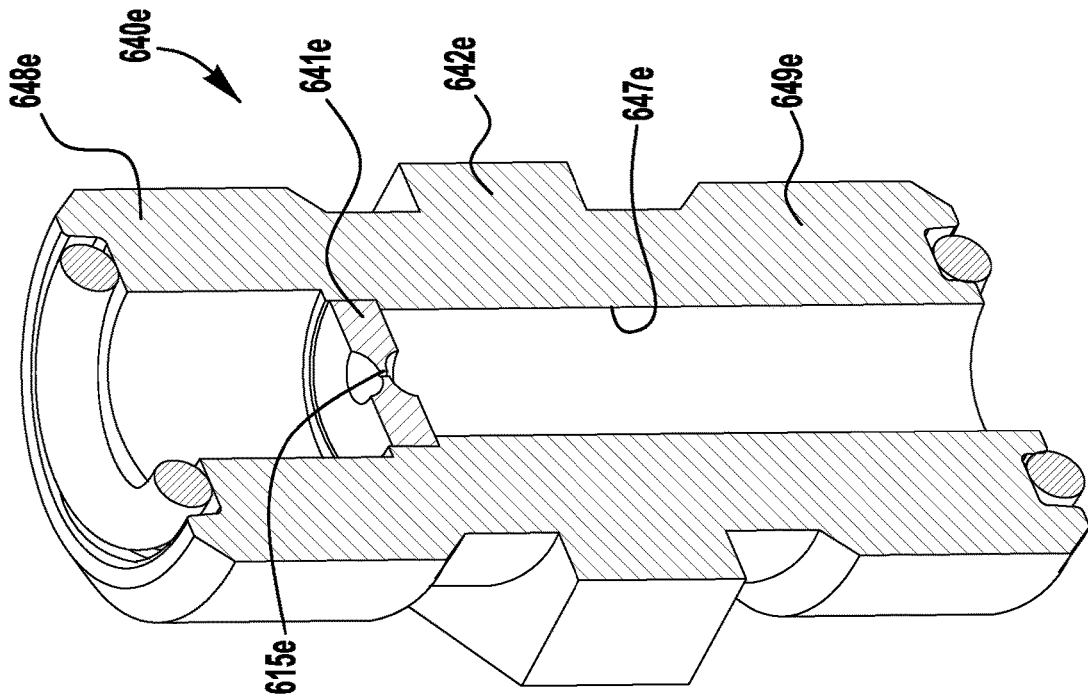

FIG. 14E

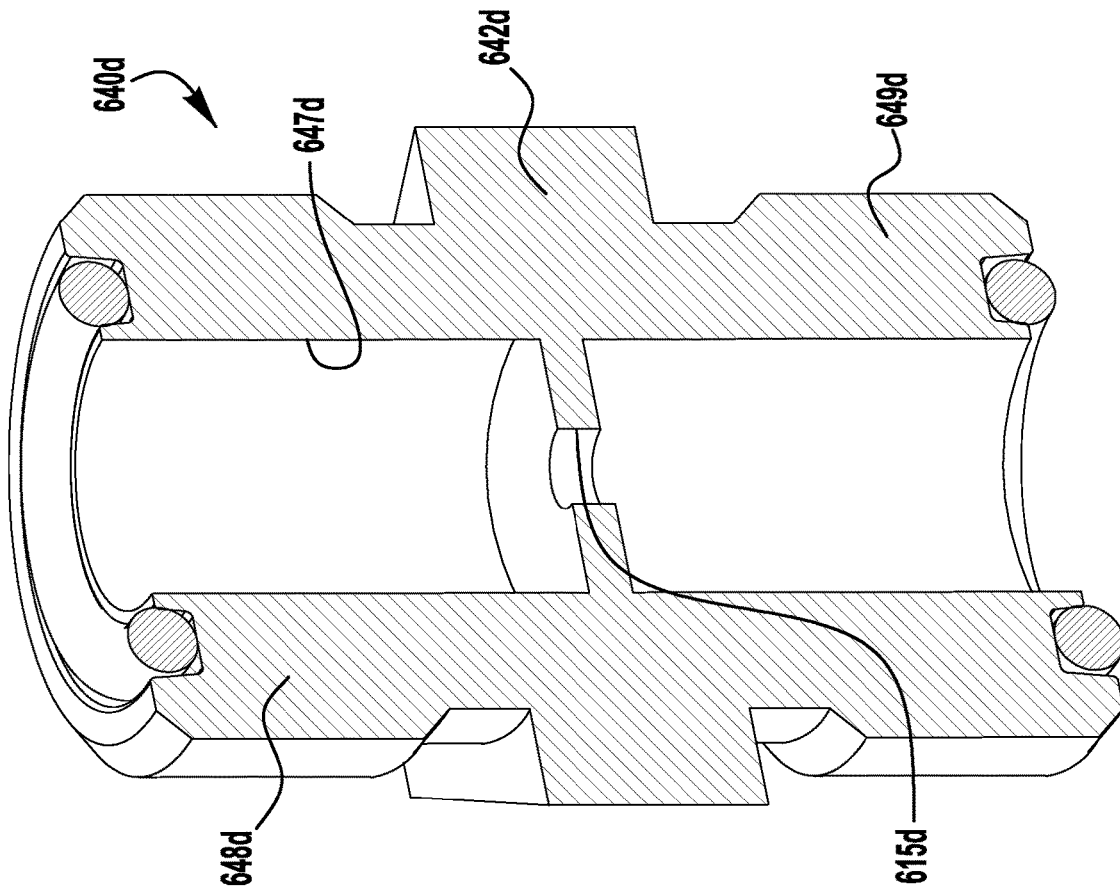

FIG. 14D

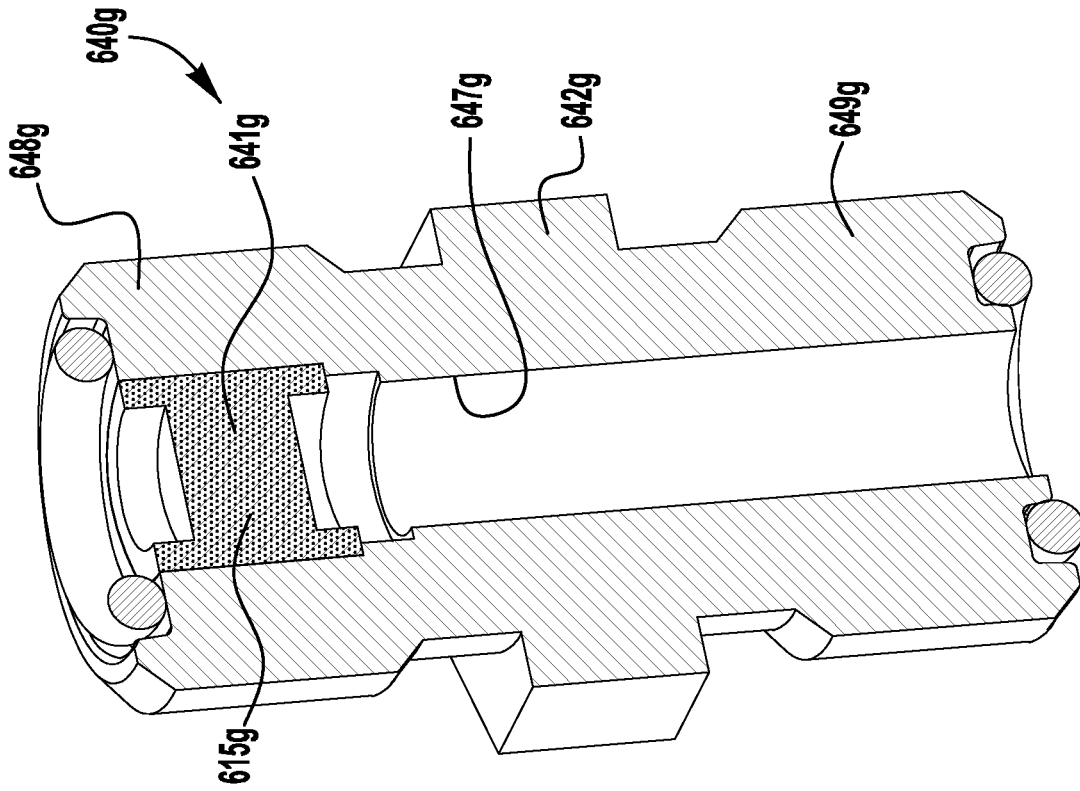

FIG. 14G

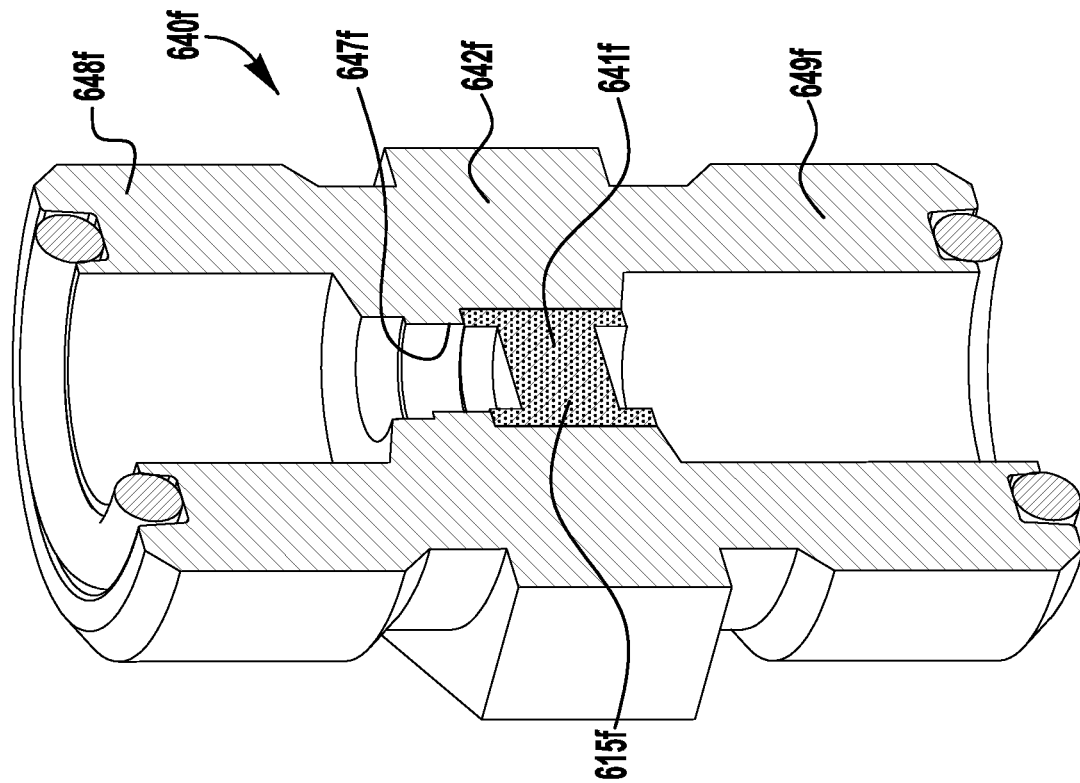

FIG. 14F

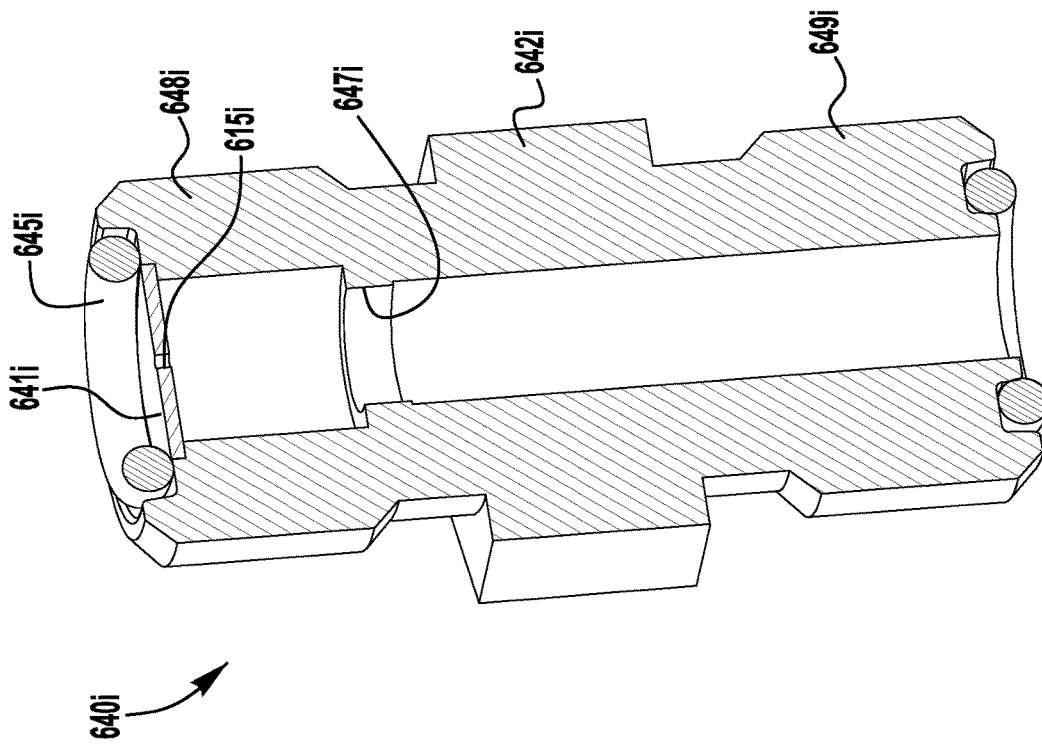

FIG. 14I

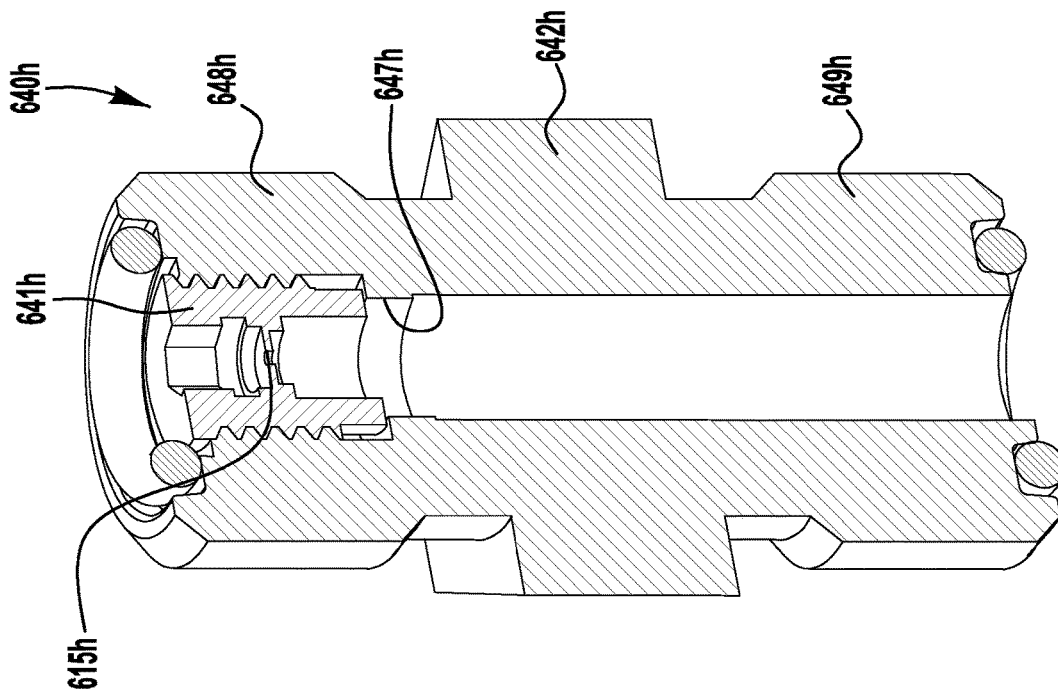

FIG. 14H

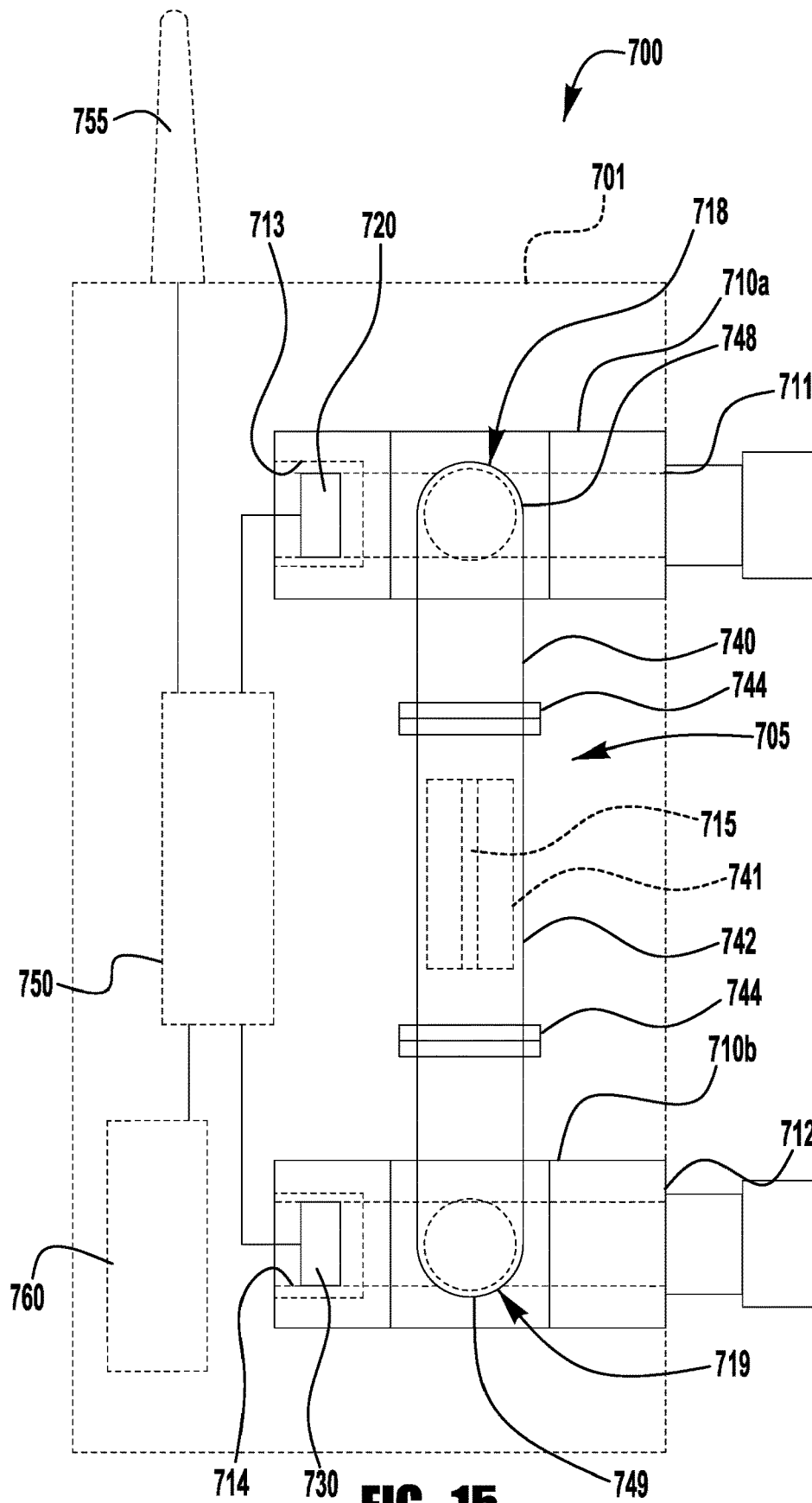

FIG. 15

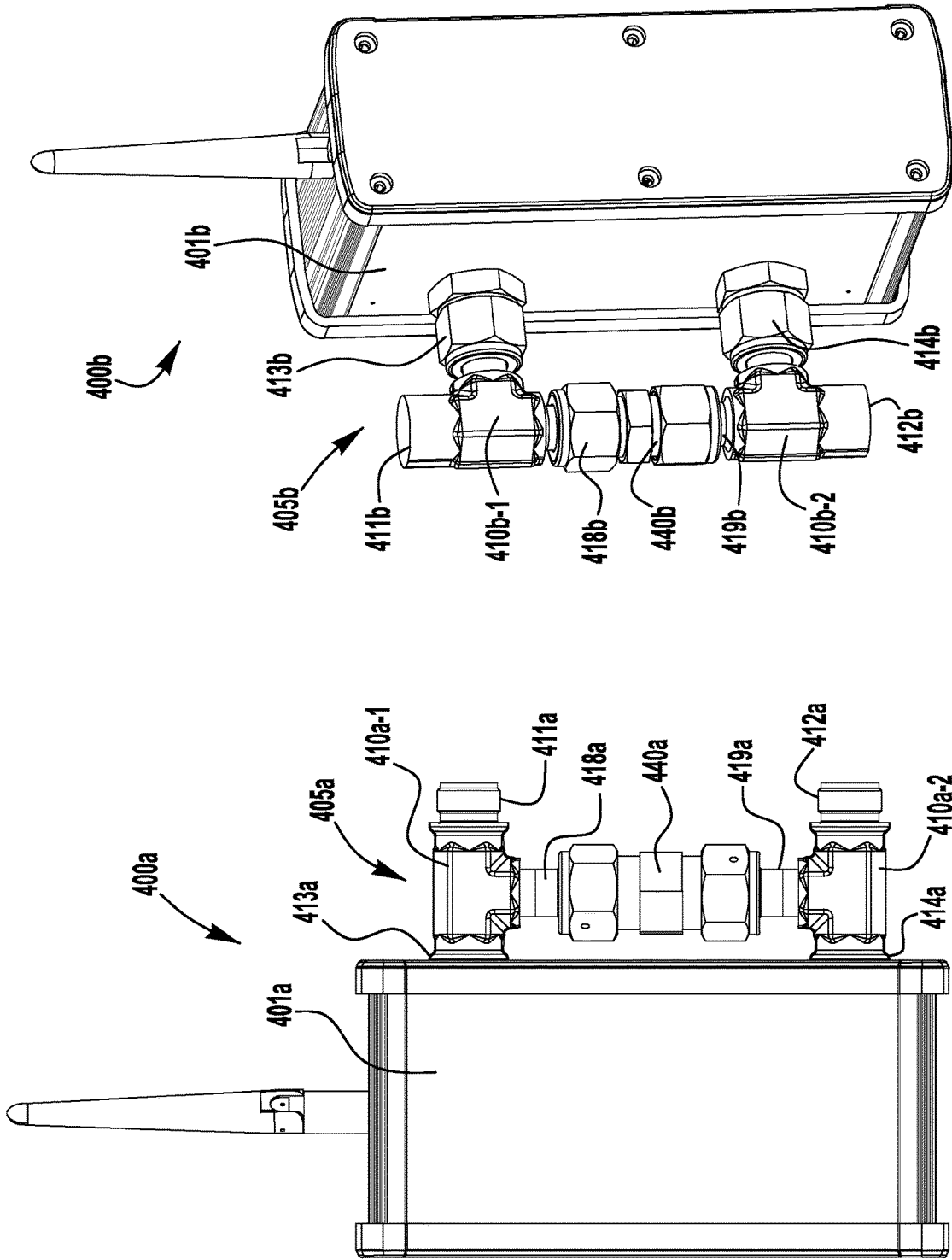

FIG. 16B

FIG. 16A

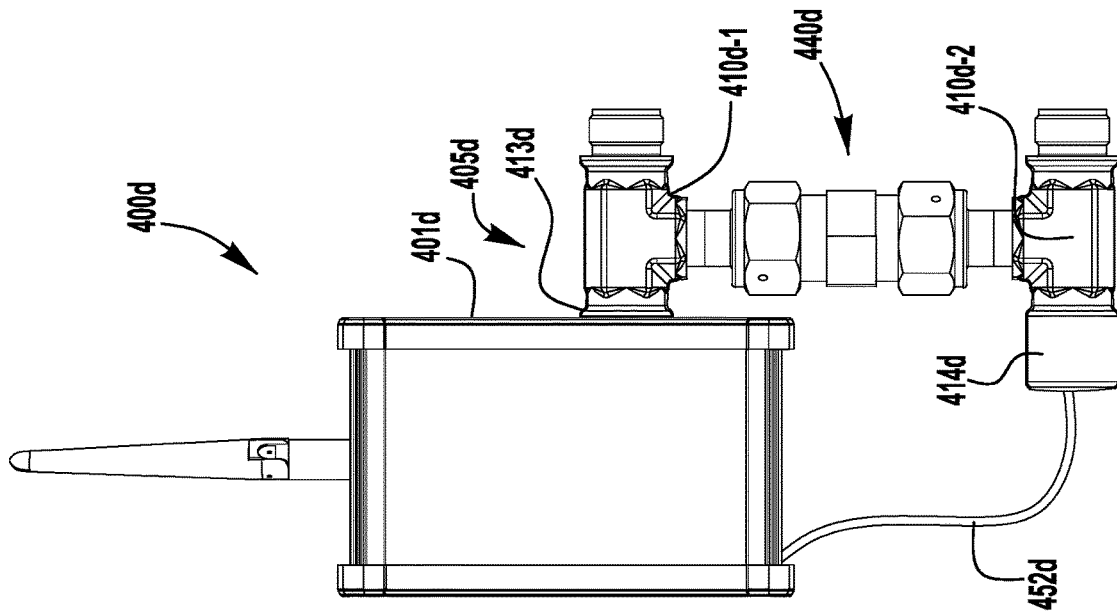

FIG. 16D

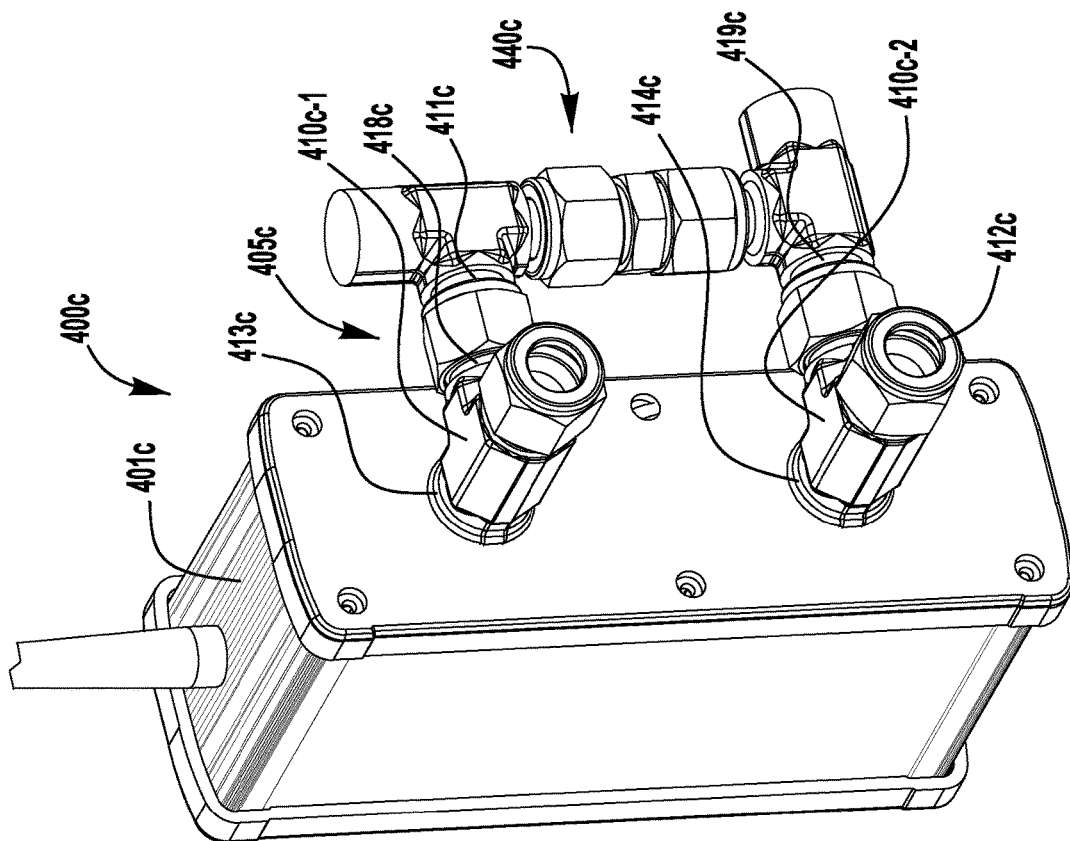

FIG. 16C

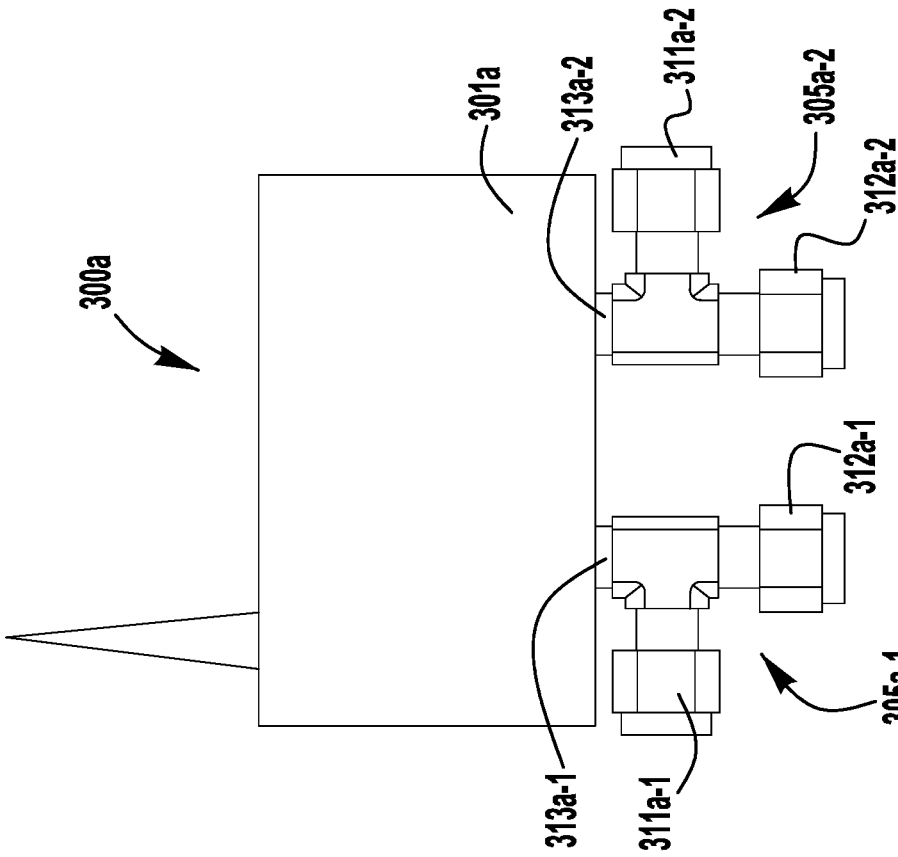

FIG. 18A

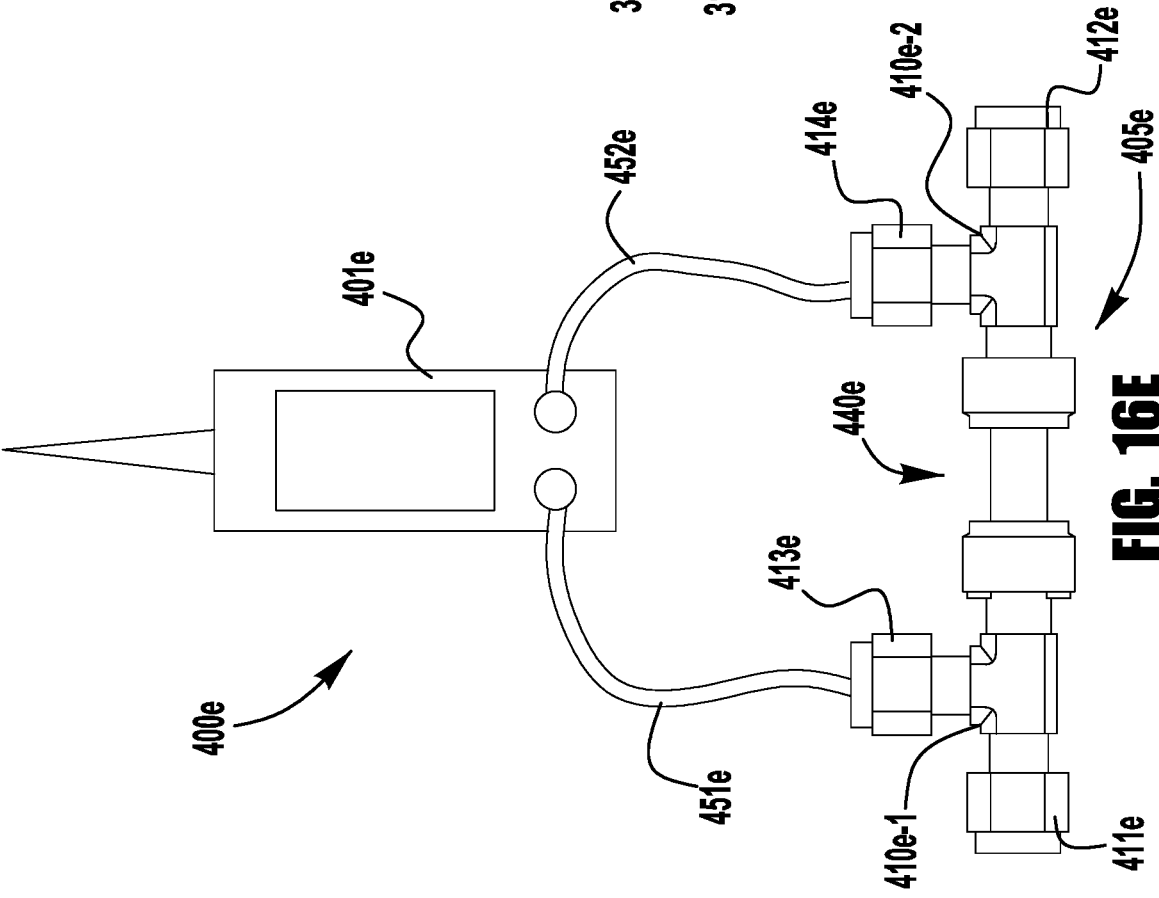

FIG. 16E

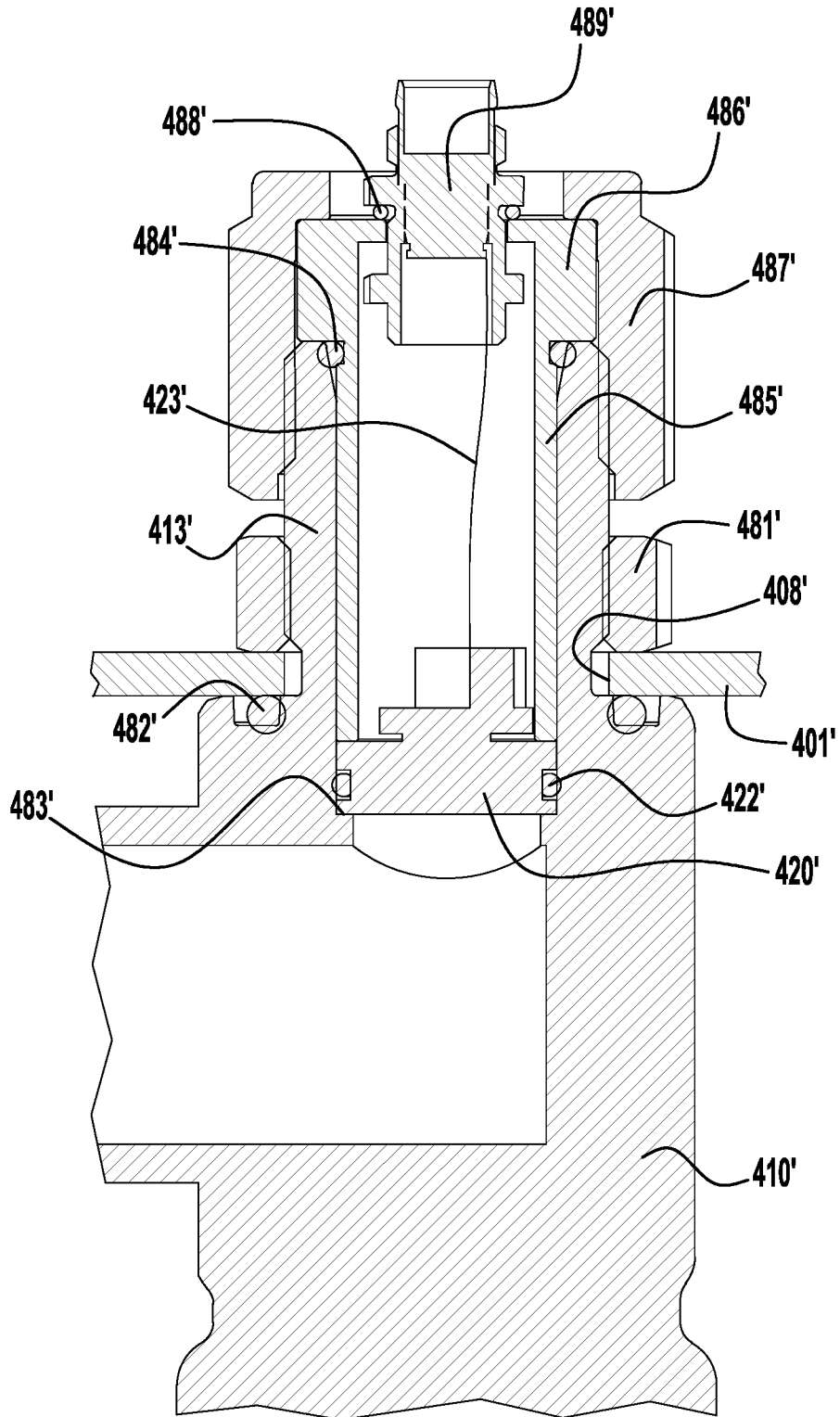

FIG. 17

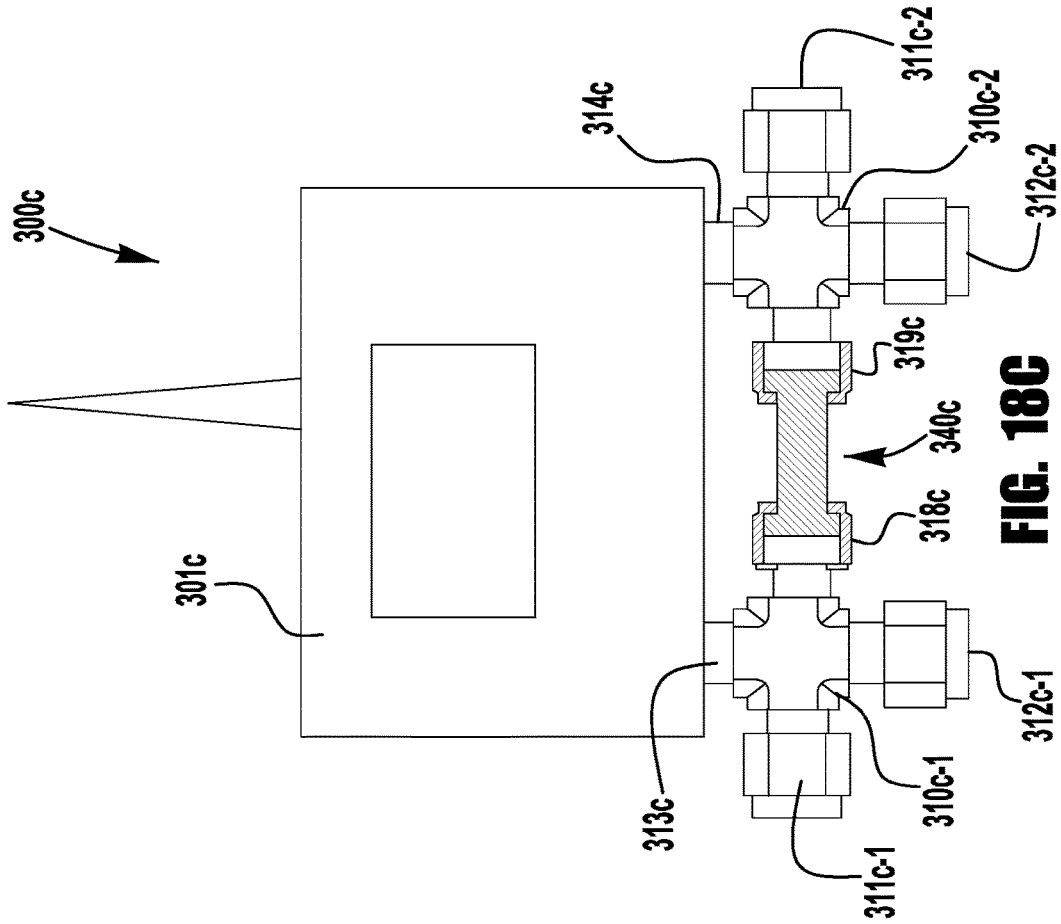

FIG. 18C

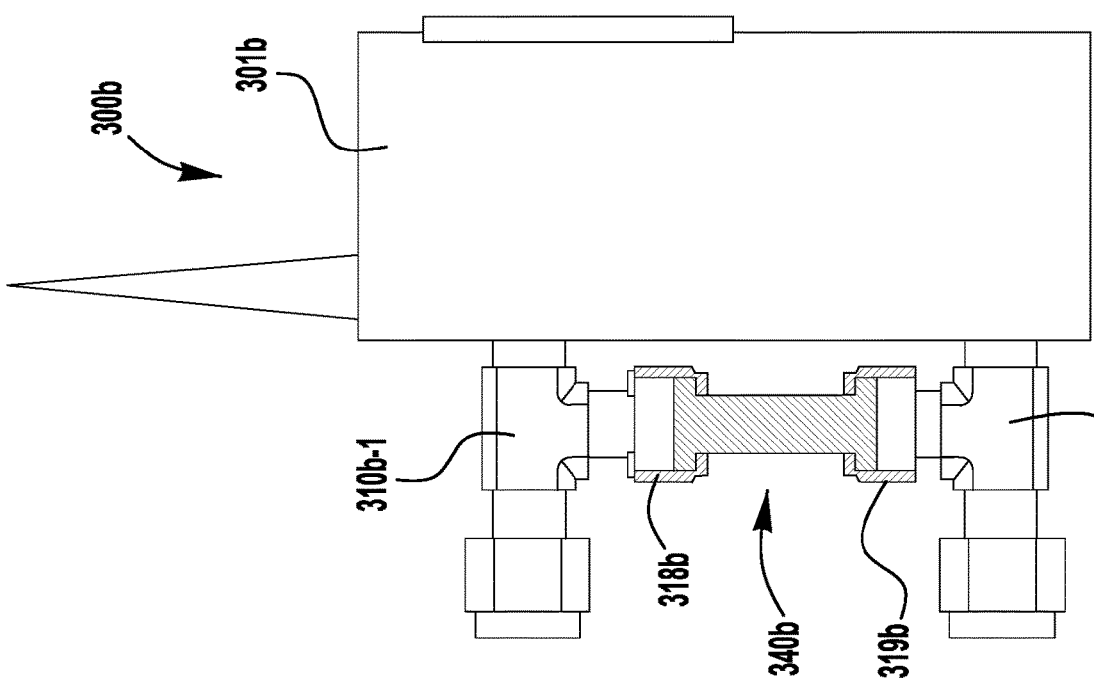

FIG. 18B

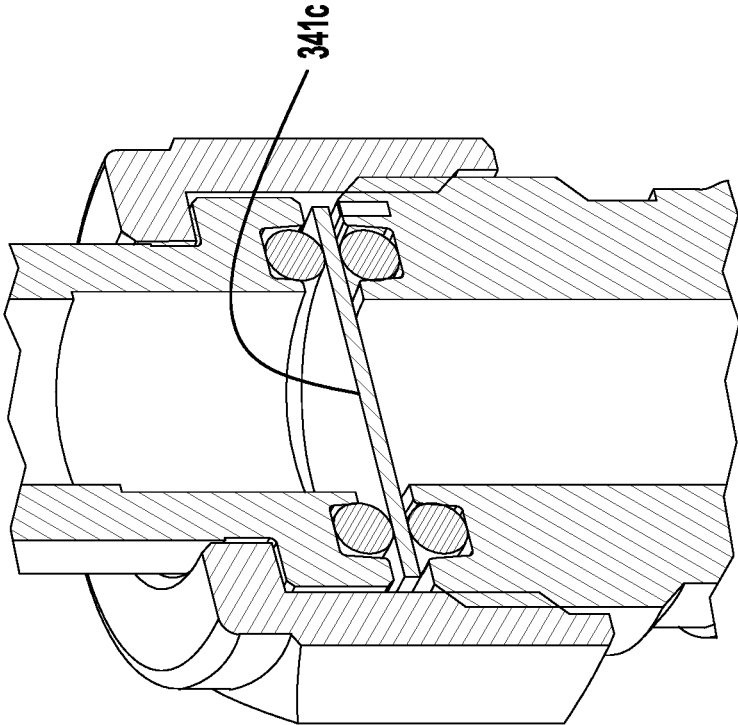

FIG. 18E

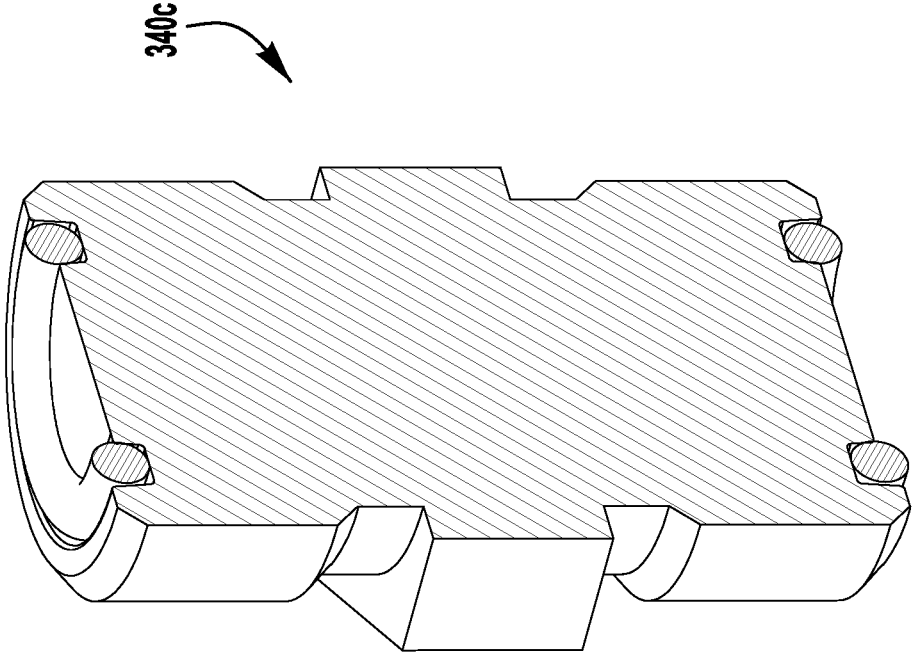

FIG. 18D

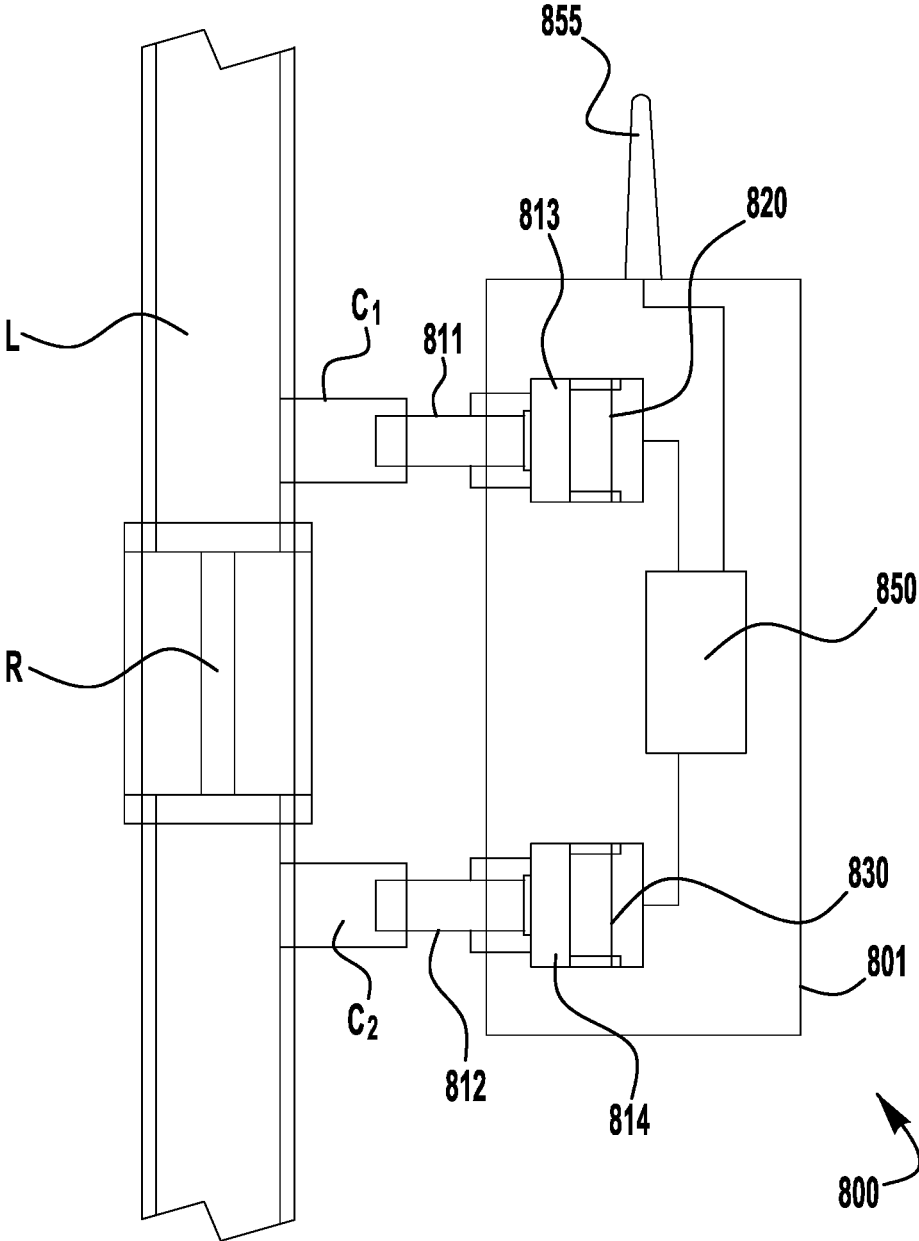

FIG. 19

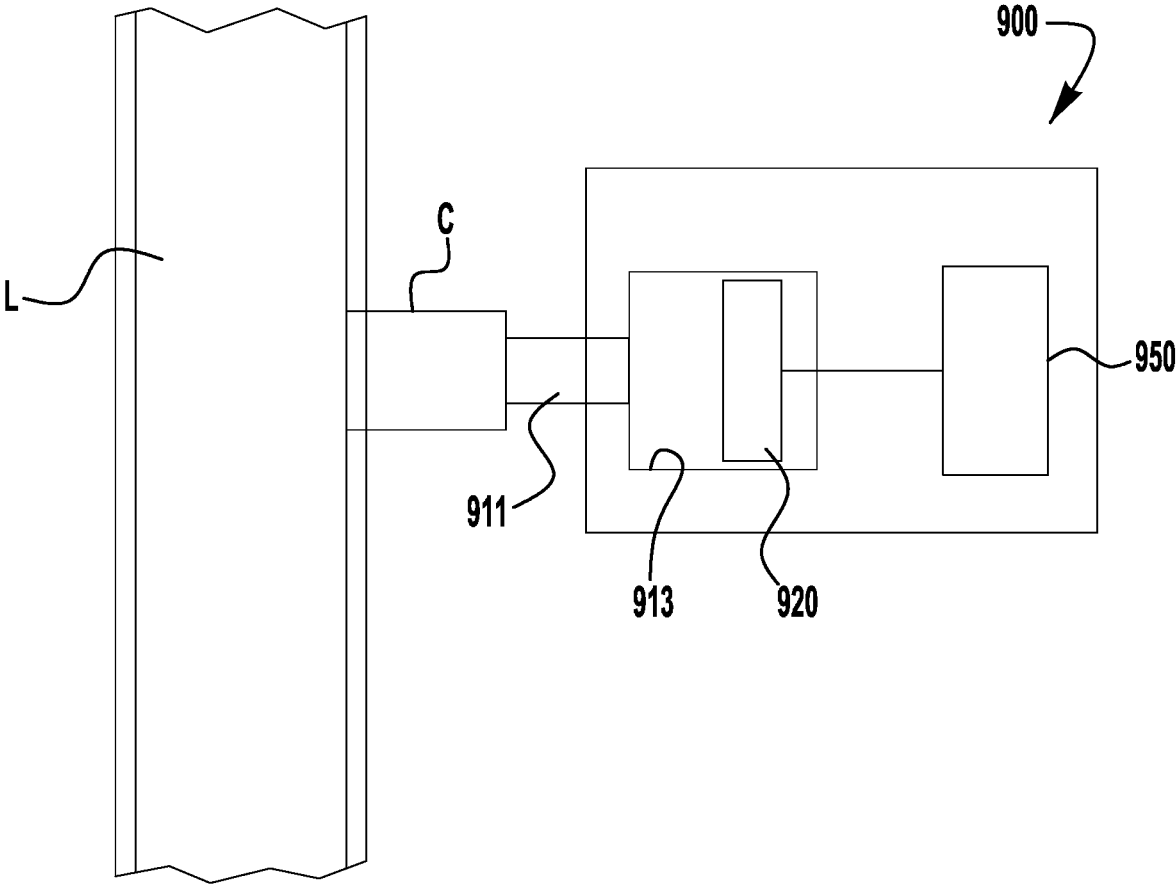
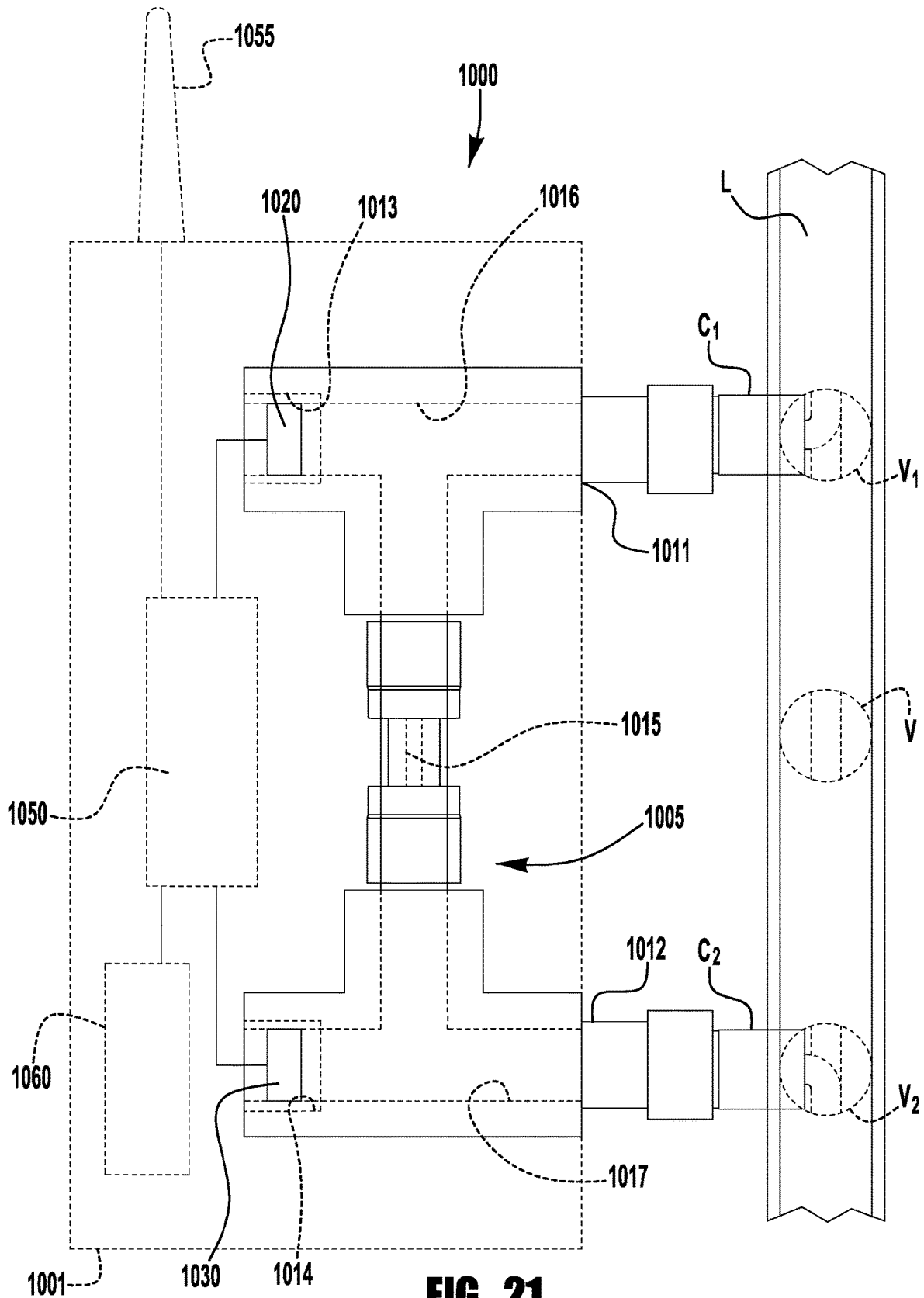

FIG. 20



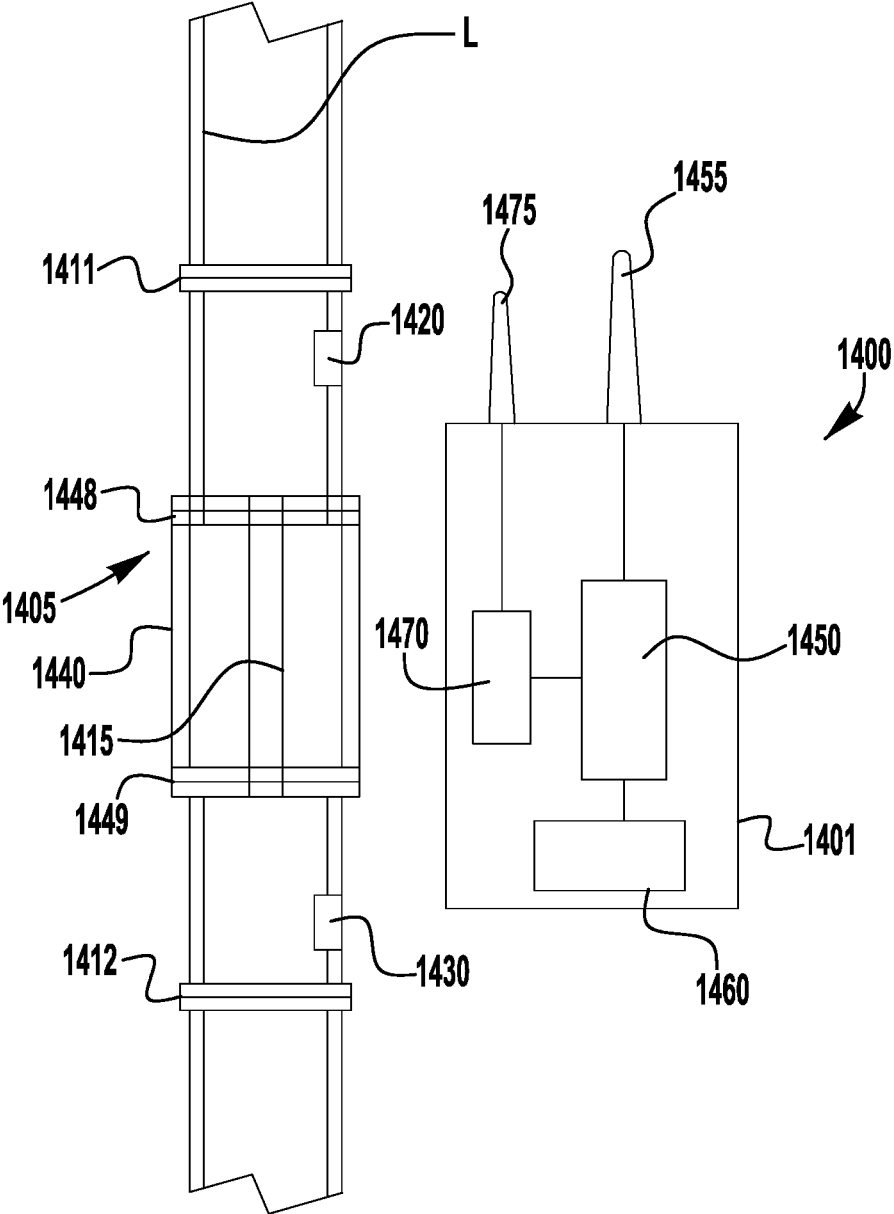

FIG. 22

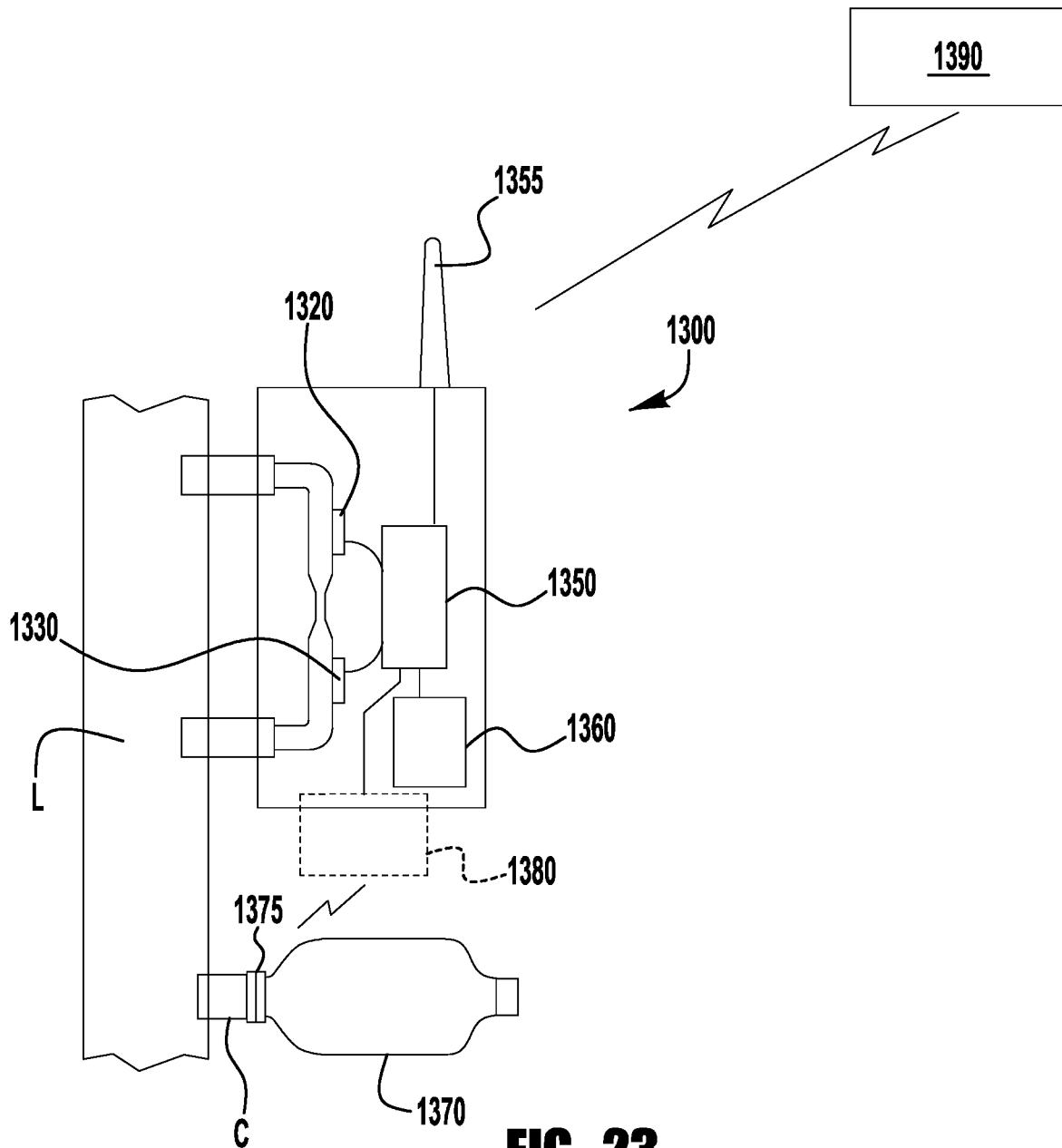

FIG. 23

FLUID MONITORING MODULE ARRANGEMENTS

CROSS-REFERENCE TO RELATED APPLICATIONS

This application is a continuation of U.S. Non-Provisional patent application Ser. No. 16/573,289, filed on Sep. 17, 2019, for FLUID MONITORING MODULE ARRANGEMENTS which claims the benefit of U.S. Provisional Patent Application Ser. No. 62/732,848, filed on Sep. 18, 2018 and entitled LAMINAR FLOW ELEMENT, U.S. Provisional Patent Application Ser. No. 62/775,066, filed on Dec. 4, 2018 and entitled FLOW SENSING MODULE, U.S. Provisional Patent Application Ser. No. 62/844,383, filed on May 7, 2019 and entitled FLUID MONITORING MODULE ARRANGEMENTS, U.S. Provisional Patent Application Ser. No. 62/844,390, filed on May 7, 2019 and entitled FLUID MONITORING MODULE ARRANGEMENTS, U.S. Provisional Patent Application Ser. No. 62/844,399, filed on May 7, 2019 and entitled FLUID MONITORING MODULE ARRANGEMENTS, and U.S. Provisional Patent Application Ser. No. 62/895,115, filed on Sep. 3, 2019 and entitled FLUID MONITORING MODULE ARRANGEMENTS, the entire disclosures of each of which are incorporated herein by reference.

BACKGROUND

Laminar flow elements (or LFEs) are generally used to measure the flow of gases, for example, for use with mass flowmeters or other such monitoring devices. A conventional laminar flow element operates by producing a differential pressure that is proportional to the velocity of the gas passing through a section of the laminar flow element, which is specifically configured to maintain the gas flow in a laminar state. Upstream and downstream pressure sensors detect this pressure differential, which is used to calculate the flow rate. Due to the typical length-to-diameter requirements of the restricting flow path of a laminar flow element (e.g., a 25:1 ratio), large size, intricate machining, or complex assembly requirements often result in increased manufacturing costs, extensive lead times, and/or undesirably large LFE components.

SUMMARY

According to an aspect of the present disclosure, a flow sensing device includes a first body member defining an inlet port, an upstream sensor port, and a first connecting port; a second body member defining an outlet port, a downstream sensor port, and a second connecting port; a flow restricting element defining a flow restricting passage and including a first end connection coupled to the first connecting port and a second end connection coupled to the second connecting port, such that the flow restricting passage is disposed between the inlet port and the outlet port, and between the upstream sensor port and the downstream sensor port; a first fluid sensor assembled with the upstream sensor port; and a second fluid sensor assembled with the downstream sensor port.

According to another aspect of the present disclosure, a fluid monitoring module includes a flow sensing device and a controller. The flow sensing device includes a first body member defining an inlet port, an upstream sensor port, and a first connecting port; a second body member defining an outlet port, a downstream sensor port, and a second con-

necting port; a flow restricting element defining a flow restricting passage and including a first end connection coupled to the first connecting port and a second end connection coupled to the second connecting port, such that the flow restricting passage is disposed between the inlet port and the outlet port, and between the upstream sensor port and the downstream sensor port; a first fluid sensor assembled with the upstream sensor port; and a second fluid sensor assembled with the downstream sensor port. The controller is in circuit communication with the first and second fluid sensors for receiving at least one of pressure indicating signals and temperature indicating signals from each of the first and second fluid sensors, and for measuring fluid data based on the received signals.

According to another aspect of the present disclosure, a fluid monitoring module includes an enclosure, a fluid sensing device assembled with the enclosure, and a controller disposed within the enclosure. The fluid sensing device includes a first body member defining a first end port, a first sensor port, and a first connecting port; a second body member defining a second end port, a second sensor port, and a second connecting port; a first fluid sensor assembled with the first sensor port; and a second fluid sensor assembled with the second sensor port. The controller is in circuit communication with the first and second fluid sensors for receiving at least one of pressure indicating signals and temperature indicating signals from each of the first and second fluid sensors, and for measuring fluid data based on the received signals. The first end port, the second end port, the first connecting port, and the second connecting port are external to the enclosure.

BRIEF DESCRIPTION OF THE DRAWINGS

Further advantages and benefits will become apparent to those skilled in the art after considering the following description and appended claims in conjunction with the accompanying drawings, in which:

FIG. 1 is a cross-sectional view of an exemplary flow sensing device, in accordance with an aspect of the present disclosure;

FIG. 1A is a perspective view of the flow sensing device of FIG. 1;

FIG. 1B is a side view of a multiple flow sensing device system, in accordance with another aspect of the present disclosure;

FIG. 2 is a cross-sectional view of an exemplary flow sensing device, in accordance with another aspect of the present disclosure;

FIG. 3 is a cross-sectional view of an exemplary flow sensing device, in accordance with another aspect of the present disclosure;

FIG. 4 is a cross-sectional view of an exemplary flow sensing device, in accordance with another aspect of the present disclosure;

FIG. 5 is a cross-sectional view of an exemplary flow sensing device, in accordance with another aspect of the present disclosure;

FIG. 6 is a cross-sectional view of an exemplary flow sensing device, in accordance with another aspect of the present disclosure;

FIG. 7 is a cross-sectional view of an exemplary flow sensing device, in accordance with another aspect of the present disclosure;

FIG. 8 is a schematic view of a flow sensing device, in accordance with another aspect of the present disclosure;

FIG. 9 is a schematic view of another flow sensing device, in accordance with another aspect of the present disclosure; and

FIG. 10A is a front perspective view of an exemplary wireless fluid monitoring module, in accordance with another aspect of the present disclosure;

FIG. 10B is a rear perspective view of the wireless fluid monitoring module of FIG. 10A;

FIG. 10C is an exploded perspective view of the wireless fluid monitoring module of FIG. 10A;

FIG. 11A is a side cross-sectional view of the wireless fluid monitoring module of FIG. 10A;

FIG. 11B is a top cross-sectional view of the wireless fluid monitoring module of FIG. 10A;

FIG. 12 is a side cross-sectional view of another exemplary wireless fluid monitoring module, in accordance with another aspect of the present application;

FIG. 13A is a perspective view of another exemplary wireless fluid monitoring module, in accordance with another aspect of the present disclosure;

FIG. 13B is a perspective view of another exemplary wireless fluid monitoring module, in accordance with another aspect of the present disclosure;

FIG. 13C is a perspective view of another exemplary wireless fluid monitoring module, in accordance with another aspect of the present disclosure;

FIG. 14 is a schematic view of a fluid monitoring module, in accordance with another aspect of the present disclosure;

FIGS. 14A-14I are cross-sectional views of exemplary flow restricting elements for a fluid monitoring module, in accordance with another aspect of the present disclosure;

FIG. 15 is a schematic view of another fluid monitoring module, in accordance with another aspect of the present disclosure;

FIG. 16A is a side view of an exemplary wireless fluid monitoring module having an external flow restricting element, in accordance with another aspect of the present disclosure;

FIG. 16B is a side view of another exemplary wireless fluid monitoring module having an external flow restricting element, in accordance with another aspect of the present disclosure;

FIG. 16C is a side view of another exemplary wireless fluid monitoring module having an external flow restricting element, in accordance with another aspect of the present disclosure;

FIG. 16D is a side view of another exemplary wireless fluid monitoring module having an external flow restricting element, in accordance with another aspect of the present disclosure;

FIG. 16E is a side view of another exemplary wireless fluid monitoring module having an external flow restricting element, in accordance with another aspect of the present disclosure;

FIG. 17 is a side cross-sectional view of an exemplary sensor port mounting arrangement for a wireless fluid monitoring module having an external flow restricting element;

FIG. 18A is a side view of an exemplary wireless fluid monitoring module having a dual fluid monitoring arrangement, in accordance with another aspect of the present disclosure;

FIG. 18B is a side view of another exemplary wireless fluid monitoring module having a dual fluid monitoring arrangement, in accordance with another aspect of the present disclosure;

FIG. 18C is a side view of another exemplary wireless fluid monitoring module having a dual fluid monitoring arrangement, in accordance with another aspect of the present disclosure;

FIG. 18D is a cross-sectional perspective view of an exemplary blank coupling connection, in accordance with another aspect of the present disclosure;

FIG. 18E is a cross-sectional perspective view of an exemplary coupling connection with blank disc insert, in accordance with another aspect of the present disclosure;

FIG. 19 is a schematic view of a fluid system with a portable fluid monitoring module, in accordance with another aspect of the present disclosure;

FIG. 20 is a schematic view of another fluid system with another portable fluid monitoring module, in accordance with another aspect of the present disclosure;

FIG. 21 is a schematic view of another fluid system with another portable fluid monitoring module, in accordance with another aspect of the present disclosure;

FIG. 22 is a schematic view of another fluid system with another portable fluid monitoring module, in accordance with another aspect of the present disclosure; and

FIG. 23 is a schematic view of an exemplary fluid monitoring and grab sampling system, in accordance with another aspect of the present disclosure.

DETAILED DESCRIPTION

While various inventive aspects, concepts and features of the inventions may be described and illustrated herein as embodied in combination in the exemplary embodiments, these various aspects, concepts and features may be used in many alternative embodiments, either individually or in various combinations and sub-combinations thereof. Unless expressly excluded herein all such combinations and sub-combinations are intended to be within the scope of the present inventions. Still further, while various alternative embodiments as to the various aspects, concepts and features of the inventions—such as alternative materials, structures, configurations, methods, circuits, devices and components, software, hardware, control logic, alternatives as to form, fit and function, and so on—may be described herein, such descriptions are not intended to be a complete or exhaustive list of available alternative embodiments, whether presently known or later developed. Those skilled in the art may readily adopt one or more of the inventive aspects, concepts or features into additional embodiments and uses within the scope of the present inventions even if such embodiments are not expressly disclosed herein. Additionally, even though some features, concepts or aspects of the inventions may be described herein as being a preferred arrangement or method, such description is not intended to suggest that such feature is required or necessary unless expressly so stated. Still further, exemplary or representative values and ranges may be included to assist in understanding the present disclosure, however, such values and ranges are not to be construed in a limiting sense and are intended to be critical values or ranges only if so expressly stated. Still further, exemplary or representative values and ranges may be included to assist in understanding the present disclosure, however, such values and ranges are not to be construed in a limiting sense and are intended to be critical values or ranges only if so expressly stated. Parameters identified as “approximate” or “about” a specified value are intended to include both the specified value and values within 10% of the specified value, unless expressly stated otherwise. Further, it is to be understood that the drawings accompanying

the present disclosure may, but need not, be to scale, and therefore may be understood as teaching various ratios and proportions evident in the drawings. Moreover, while various aspects, features and concepts may be expressly identified herein as being inventive or forming part of an invention, such identification is not intended to be exclusive, but rather there may be inventive aspects, concepts and features that are fully described herein without being expressly identified as such or as part of a specific invention, the inventions instead being set forth in the appended claims. Descriptions of exemplary methods or processes are not limited to inclusion of all steps as being required in all cases, nor is the order that the steps are presented to be construed as required or necessary unless expressly so stated.

The Detailed Description merely describes exemplary embodiments and is not intended to limit the scope of the claims in any way. Indeed, the invention as claimed is broader than and unlimited by the exemplary embodiments, and the terms used in the claims have their full ordinary meaning. For example, while specific exemplary embodiments in the present disclosure describe flow sensing devices with pressure sensors for measuring differential pressure and correlating the differential pressure to flow rate, in other embodiments, one or more of the features described herein may be applied to other fluid system components, including, for example, conduit fittings and valves.

According to an aspect of the present disclosure, as illustrated in the cross-sectional view of FIG. 1, a flow sensing device **100** may be provided with a cross-shaped body **110** including laterally extending inlet and outlet ports **111**, **112** and axially extending upstream and downstream sensor ports **113**, **114**. As shown, the inlet port **111** may, but need not, be substantially coaxial with the outlet port **112** (along axis X, as shown), and the upstream sensor port **113** may, but need not, be substantially coaxial with the downstream sensor port **114** (along axis Y, as shown). The inlet and outlet ports **111**, **112** may include any suitable fluid system connectors, including, for example, one or more tube fittings, face seal fittings, threaded pipe ends, or weld ends. The inlet port **111** is connected in fluid communication with the upstream sensor port **113** by an inlet branch port **116**, and the outlet port **112** is connected in fluid communication with the downstream sensor port **114** by an outlet branch port **117**. The upstream and downstream sensor ports **113**, **114** are connected by a flow restricting passage **115** extending generally axially from the upstream sensor port **113** to the downstream sensor port **114**. While the flow restricting passage **115** may be specifically configured to maintain laminar flow through the device **100** (e.g., as a laminar flow element, or LFE), in other embodiments, the flow restricting passage may permit turbulent flow, or a combination of laminar flow and turbulent flow, while still providing for a consistent desired flow rate or range of flow rates. As shown, other than the branch ports **116**, **117**, the body **110** may (but need not) be substantially symmetrical about either or both of the X and Y axes.

An upstream pressure sensor **120** is installed in the upstream sensor port **113** and is configured to generate a signal corresponding to an upstream pressure, and a downstream pressure sensor **130** is installed in the downstream sensor port and is configured to generate a signal corresponding to a downstream pressure. The pressure sensors **120**, **130** may transmit signals to an electronic controller, shown schematically at **150**, in circuit communication with the pressure sensors, for example, by wired or wireless communication, with the electronic controller being configured to evaluate the upstream and downstream pressures

corresponding to the received signals, to determine a pressure differential across the flow restricting passage and a corresponding flow rate through the flow sensing device **100**.

The upstream and downstream pressure sensors **120**, **130** may include any suitable type of pressure sensor (e.g., a piezoresistive strain gauge, a capacitive pressure sensor, an electromagnetic pressure sensor, a piezoelectric pressure sensor), which may be securely retained within the corresponding sensor port **113**, **114**, for example, using a retaining ring **121**, **131**, and may be sealed within the corresponding sensor port **113**, **114**, for example, using an O-ring or gasket seal **122**, **132**. In an exemplary embodiment, the sensor may be configured to detect or measure both pressure and temperature, and transmit pressure and temperature indicating signals to the controller. The controller may be configured to process the pressure and temperature indicating signals, for example, to determine pressure, temperature, and/or flow rate, and/or to provide a measured output of any one or more of these parameters. An exemplary sensor configured to measure pressure and temperature is the LD series piezoresistive OEM pressure transmitter, manufactured by Keller.

The compact arrangement of the cross-shaped body **110** of the flow sensing device **100** may allow the flow sensing device to be incorporated into smaller enclosures or smaller equipment, or more seamlessly into existing systems. While a system including a plurality of flow sensing devices may include a separate controller connected with each of the flow sensing devices, in another embodiment, the compact flow sensing devices may be arranged and configured for electrical connection with a single controller. FIG. 1B illustrates an exemplary system **10** including a plurality of flow sensing devices **100** arranged end to end, with upstream and downstream pressure sensors **120**, **130** electrically connected to the controller **150**, and inlet and outlet ports **111**, **112** connected to parallel fluid lines **11**, **12**.

Many different suitable laminar flow restricting passages may be utilized. In some embodiments, one or more flow restricting passages may be integrally formed in the body, for example, by drilling, machining, or additive manufacturing (e.g., 3D printing). In other embodiments, one or more flow restricting passages may be defined by a flow restricting element formed from one or more inserts (e.g. plugs, plates, etc.) installed in a cavity in the body between the upstream and downstream sensor ports. This type of flow passage insert arrangement may facilitate formation of the flow passages, and/or may allow for adaptability of the flow sensing device, for example, by allowing for different ranges of flow rate and pressure differential.

In one example, as shown in FIG. 2, a body **110a** of a flow sensing device **100a** includes a narrow axially extending (e.g., capillary) passage **115a** extends between the upstream sensor port **113a** and the downstream sensor port **114a**. In another exemplary embodiment, as shown in FIG. 3, a body **110b** of a flow sensing device **100b** includes multiple narrow axially extending passages **115b** extends between the upstream sensor port **113b** and the downstream sensor port **114b**, for example, to provide for increased laminar flow while limiting the axial length of the body **110b**.

In another exemplary embodiment, as shown schematically in FIG. 4, the body **110c** of a flow sensing device **100c** may be provided with one or more narrow, laminar flow restricting passages **115c** having a plurality of coils or convolutions arranged to provide an extended passage length over a limited axial dimension of the body, between the upstream and downstream sensor ports **113c**, **114c**. These convoluted or coiled passages may be formed, for

example, by additive manufacturing to facilitate production of one or more convoluted laminar flow restricting passages **115c** between the upstream sensor port **113c** and the downstream sensor port **114c**. In another exemplary embodiment, as shown in FIG. 5, the body **110d** of a flow sensing device **100d** may include a central cavity **119d** retaining a stack of plates **140d** having holes and/or slots aligned to define the passage(s) **115d**. In other embodiments, convoluted or selectively contoured passages (formed, for example, by additive manufacturing) may be utilized to provide or perform other fluid flow functions such as, for example, mixing, swirling, heat/cold tracing or other such functionality.

In other exemplary embodiments, as shown in FIG. 6, a body **110e** of a flow sensing device **100e** may include a flow restricting element **140e** (e.g., a sintered element) installed in a cavity **119e** of the body **110e** to define a flow passage **115e** that restricts flow to a desired flow condition (e.g., laminar flow and/or a desired flow range). An O-ring or other such gasket seal **149e** may be provided around the flow restricting element **140e** (e.g., in an inner peripheral groove in the body cavity **119e**, and/or in an outer peripheral groove in the flow restricting element **140e**) may be provided around the flow restricting element to seal against leakage/flow past the periphery of the flow restricting element. In another exemplary embodiment, as shown in FIG. 7, the body **110f** of a flow sensing device **100f** may be formed by additive manufacturing to facilitate production of a porous, axially extending portion **140f** of the body between the upstream and downstream sensor ports **113f**, **114f**, with a pore size and density selected to provide a desired flow condition.

Flow restricting sintered elements or other such porous or narrow passage restricting portions may tend to get blocked or clogged by contaminants in the system fluid, which may affect system flow rates and the flow readings provided by the device. According to another aspect of the present disclosure, a flow sensing device body may be provided with a flow restricting element shaped or otherwise configured to divert or collect contaminants into a recessed portion of the body cavity, thereby minimizing the clogging or blocking of the porous flow restricting element.

FIG. 8 schematically illustrates an exemplary flow sensing device **1100** including a body member **1110** having inlet and outlet ports **1111**, **1112** and upstream and downstream sensor ports **1113**, **1114**. The inlet and outlet ports **1111**, **1112** may include any suitable fluid system connectors, including, for example, one or more tube fittings, face seal fittings, threaded pipe ends, or weld ends. The inlet port **1111** is connected in fluid communication with the upstream sensor port **1113** by an internal upstream passage **1116**, and the outlet port **1112** is connected in fluid communication with the downstream sensor port **1114** by an internal downstream passage **1117**. The upstream and downstream sensor ports **1113**, **1114** sealingly retain sensors **1120**, **1130** and are connected by a porous flow restricting element **1140** disposed in a cavity **1119** of the body **1110** to define a flow restricting passage **1115**. While the flow restricting passage **1115** may be specifically configured to maintain laminar flow through the device **1100**, in other embodiments, the flow restricting passage may permit turbulent flow, or a combination of laminar flow and turbulent flow, while still providing for a consistent desired flow rate or range of flow rates.

As shown, the exemplary flow restricting element **1140** includes a conical central porous portion **1141** and an outer peripheral solid or non-porous portion **1142** that forms an annular recess into which fluid contaminants may collect

without blocking or further restricting the flow path. The internal upstream passage **1116** may be shaped to direct fluid flow toward the surfaces of the body cavity **1119** and the annular recess **1142**. Alternatively, as shown, an upstream end or tip **1143** of the flow restricting element may also be solid or non-porous, and the internal upstream passage **1116** in the body **1110** may be shaped to direct fluid flow toward the solid restricting element tip, such that the contoured tip directs contaminants radially outward while minimizing any tendency for the contaminants to become embedded in the porous portions of the flow restricting element. Other porous element shapes may be utilized including, for example, hemispherical or pyramid shaped elements. The flow restricting element **1140** may be provided as an insert for installation in the body cavity **1119**, similar to the embodiment of FIG. 6. Alternatively, the flow restricting element **1140** may be integrally formed with the body **1110**, similar to the embodiment of FIG. 7. In either case the flow restricting element may be formed using additive manufacturing (e.g., 3D printing) which may be well suited to selectively form portions of the element in porous and non-porous materials.

Porous restricting portions or narrow restricting passages may become partially blocked or clogged by condensation in a gaseous fluid system, for example, where the fluid system is subjected to lower temperatures or sudden changes in temperature. According to another aspect of the present disclosure, a flow sensing device body may be provided with a flow restriction heating arrangement, for example, to selectively evaporate or boil off condensation, or to maintain the flow restricting element at temperatures that will prevent condensation, thereby preventing this type of restricting element blockage.

FIG. 9 schematically illustrates an exemplary flow sensing device **1200** including a body member **1210** having inlet and outlet ports **1211**, **1212** and upstream and downstream sensor ports **1213**, **1214**. The inlet and outlet ports **1211**, **1212** may include any suitable fluid system connectors, including, for example, one or more tube fittings, face seal fittings, threaded pipe ends, or weld ends. The inlet port **1211** is connected in fluid communication with the upstream sensor port **1213** by an internal upstream passage **1216**, and the outlet port **1212** is connected in fluid communication with the downstream sensor port **1214** by an internal downstream passage **1217**. The upstream and downstream sensor ports **1213**, **1214** sealingly retain sensors **1220**, **1230** and are connected by a flow restricting element **1240** disposed in a cavity **1219** of the body **1210** and defining a flow restricting passage **1215** (e.g., one or more formed passages or a porous flow restricting material). While the flow restricting passage **1215** may be specifically configured to maintain laminar flow through the device **1200**, in other embodiments, the flow restricting passage may permit turbulent flow, or a combination of laminar flow and turbulent flow, while still providing for a consistent desired flow rate or range of flow rates.

As shown, the flow restricting device **1200** includes a flow restriction heating arrangement surrounding the flow passage **1215** in the flow restricting element **1240**. The heating arrangement **1270**, which may be formed in the flow restricting element **1240**, around the flow restricting element (e.g., between an outer surface of the flow restricting element and an inner surface of the body cavity **1219**), or around the body member **1210** in alignment with the flow passage. A wide variety of flow restricting heating arrangements may be utilized, including, for example: one or more heating circuits configured to receive a current for heating the flow restrict-

ing element, or one or more heat trace passages for passing heated fluid (e.g., steam) through or around the flow restricting element. The flow restricting element **1240** may be provided as an insert for installation in the body cavity **1219**, similar to the embodiment of FIG. 6. Alternatively, the flow restricting element **1240** may be integrally formed with the body **1210**, similar to the embodiment of FIG. 7. In either case the flow restricting element may be formed using additive manufacturing (e.g., 3D printing) which may be well suited to form heat trace or circuit receiving passages in or around the flow restricting element.

While the controller(s) may be separate from, and physically and electrically tethered to, the flow sensing element (s), in other embodiments, a flow sensing element may be provided in a self-contained module, for example, for ease of installation in a fluid system, with an enclosure containing the flow sensing device (with external connectors for connecting the flow sensing device with the fluid system) and the controller. The controller may be configured to communicate (e.g., by wired or wireless communication) with an external device (e.g., server, router, computer, tablet, smartphone) to deliver information about the fluid flow conditions (e.g., pressure, temperature, flow rate). Additionally or alternatively, the module may be provided with a user interface for providing information about the fluid flow conditions at the module (e.g., using an LED array or LCD display screen).

FIGS. 10A-11B illustrate various views of an exemplary fluid monitoring module **500**, including an enclosure **501** formed from a housing **502** and a cover **503** (secured together, for example, using bolts or other fasteners) enclosing a flow sensing device **505** and controller **550**. The flow sensing device **505** may, for example, be similar to any of the flow sensing devices **100a-f** described herein, and may be provided with end connectors **506** extending through openings in the enclosure **501**. Gaskets or other such seals **504** (FIG. 11A) may surround the end connectors **506** in the openings, for example, to prevent moisture or other contaminants from entering the enclosure. While the end connectors may be provided in a variety of locations and orientations, in the illustrated embodiment, the end connectors **506** extend from a common wall of the enclosure, for example, to facilitate installation into an existing fluid system. As shown in FIGS. 10C and 11A, the flow sensing device **505** may be provided with elbow fittings or other such connectors and adapters to position the end connectors **506** at the desired location and orientation. In one such example, the end connectors **506** of the module **500** may be spaced and oriented to corresponding with a conventional flow rate measuring device (e.g., a rotameter-style flow rate measuring device), such that the conventional flow rate measuring device of an existing system may be easily replaced with the module **500**. In another embodiment (not shown), the end connectors may extend axially from the fluid monitoring module, for example, to facilitate inline installation of the flow sensing device, or of multiple flow sensing devices with multiple parallel, closely spaced fluid lines. In still other embodiments, the end connectors may be offset from each other and may extend in opposite directions from opposite sides of the housing, or perpendicularly from adjacent sides of the housing.

While the module may be provided with external wiring for connection with an external power source (e.g., wall outlet), the module **500** may additionally or alternatively include one or more batteries **560**, as shown in FIG. 11A, electrically connected with the controller **550** to power the controller hardware (e.g., processor, transmitter, LEDs) and

sensors **520**, **530** of the flow sensing device **505**. As shown, the batteries **560** may be disposed in a sleeve **561**, for example, to protect and securely position the batteries. In some embodiments, the module may be provided with rechargeable batteries that may be recharged, for example, by electrically connecting external wiring of the module to an external power source. Additionally or alternatively, the enclosed batteries may serve as a back-up power source (e.g., in the event of a building power failure), with the module primarily operating off of an external power source. As shown in FIG. 10C, a spacer bracket **509** may be provided within the enclosure **501**, for example, to secure the internal components of the module in a desired position.

The exemplary flow sensing device assembly **505** includes upstream and downstream sensors **520**, **530** installed in upstream and downstream sensor ports **513**, **514** of a body member **510**. The sensors **520**, **530** are connected (e.g., by wiring within the module enclosure) to the controller **550** to transmit pressure and temperature indicating signals to the controller. The controller **550** is configured to process the pressure and temperature indicating signals, for example, to determine pressure, temperature, and/or flow rate of fluid passing through the flow sensing device, and/or to provide a measured output of any one or more of these parameters.

In the embodiment of FIGS. 10A-11B, the sensor ports **513**, **514** of the body **510** are oriented to face the sides of the housing **502**. Alternatively, as shown in FIG. 12, the sensor ports **513'**, **514'** of the body **510'** may be oriented to face the housing rear wall and the cover **503'**, allowing the width of the enclosure to be reduced. Additionally or alternatively, the battery size may be reduced (e.g., replacing two C cell batteries **560** with one D cell battery **560'**, as shown in FIG. 12) to allow the height of the enclosure to be reduced.

The module may be provided with external wiring for a wired connection with an external device (e.g., computer). Additionally or alternatively, as shown, the module **500** may be provided with a wireless transmitter (e.g., provided on a circuit board of the controller **550**) for wirelessly transmitting fluid data to a remote device (e.g., server, router, computer, tablet, smartphone), for example, using direct or indirect wireless communication with the remote device. The transmitter may be configured to communicate using any number of suitable wireless communication protocols and capabilities, such as, for example, WiFi, Bluetooth, ZigBee, RFID, NFC, and wireless USB communication. As shown, the module **500** may include an external antenna **555**, electrically connected with the controller transmitter, for enhanced wireless communication with a remote device. In an exemplary system, a WiFi gateway router may be provided for wireless communication with one or more modules, for example, to establish a browser interface (which may eliminate the need for desktop software), facilitate commissioning of field devices, establish data system/cloud interfaces, and provide for simplified troubleshooting and diagnostics.

To facilitate commissioning and control (e.g., power on/off, synchronization) of the module, the module may be provided with a user interface, such as, for example, one or more knobs, switches or buttons. In the illustrated embodiment, the module **500** includes an external, user depressible button **507** disposed in an opening in the cover **503** and positioned for actuation of a button switch **557** on the controller **550**, which may be actuated, for example, to turn on the controller, to turn off the controller, or to commission/synchronize the controller. The button **507** may be provided in a transparent or translucent material, to provide illumi-

nation from one or more LEDs **558** on the controller **550**, which may be illuminated, for example, to provide user indication of a controller status (e.g., power on/off, connectivity, recognized user actuation). The LEDs **558** may provide multi-color illumination (either by providing multiple LEDs each having different color illumination, or one or more multi-color LEDs) and/or pulsed illumination, for example, to identify multiple distinguishable status conditions.

In addition to, or instead of, wired or wireless communication with an external device, the module may be provided with a user interface configured to display fluid flow data on the module. FIG. **13A** illustrates an exemplary module **500a** including a user interface display screen **559a** (e.g., LCD, OLED) disposed on an outer surface of the enclosure (e.g., on the cover **503a**) and connected in circuit communication with the module controller, for display of one or more fluid conditions (e.g., flow rate, temperature, pressure). Alternatively, to provide a simpler output display, an LED array **559b**, **559c** may be used to provide a digital display (e.g., one or more numerical digits), as shown in FIG. **13B**, or a multi-bar proportional readout display (e.g., three or more LEDs showing proportional levels of flow rate, pressure, and/or temperature), as shown in FIG. **13C**. In an exemplary embodiment of the present disclosure, digital or multi-bar LED displays may utilize multi-color LEDs to display multiple types of fluid data using the same set of LEDs. For example, the digital LED display **559b** of FIG. **13B** may provide for illumination of the corresponding LEDs in a first color (e.g., white) to identify a measured flow rate, a second color (e.g., red) to identify a measured pressure, and a third color (e.g., green) to identify a measured temperature. Similarly, the digital LED display **559c** of FIG. **13C** may provide for illumination of the corresponding LEDs in a first color (e.g., white) to identify a proportional flow rate level, a second color (e.g., red) to identify a proportional pressure level, and a third color (e.g., green) to identify a proportional temperature level. A user may selectively toggle between fluid data by actuating a user interface (e.g., button or knob), or the display may be configured to automatically periodically switch (e.g., every 3-10 seconds) between the different fluid flow data.

In one or more exemplary embodiments, a fluid monitoring module, such as, for example, any of the modules described herein, may be configured to provide a number of desired properties and conditions, including. For example, a fluid monitoring module may be configured to provide typical desired sample stream and bypass flow ranges, including, for example, gas flow rates of about 0.05 to 20 SLPM (analyzer) or liquid flow rates of about 0.05-20 LPM (bypass). An exemplary fluid monitoring module may be configured to provide flow measurement accuracy of less than about 10% of full scale (e.g., about +/-5% accuracy), and may be configured to provide excellent repeatability and stability. An exemplary fluid monitoring module may, for example, be rated for use from about -20 C to 80 C, or at a maximum ambient temperature of about 85 C. An exemplary fluid monitoring module may, for example, be rated for operating pressures between about 50 psig and 150 psig, and may be rated for 1900 psig proof or 3500 psig burst. Exemplary materials of construction may include, for example, 316 stainless steel, Hastelloy, FKM, and FFKM. An exemplary fluid monitoring module may include appropriate safety ratings, including, for example, class 1 division 1 for the transmitter, class 1 division 2 for the gateway, ATEX Zone 1, and/or IECEx Zone 1. An exemplary fluid monitoring module may be configured for 2.4 GHz mesh

wireless communication. An exemplary fluid monitoring module may include a disposable lithium battery with at least a five year life. An exemplary fluid monitoring module may be rated for a lag time of T90=5 seconds maximum for 0.2 SLPM gas flow.

In one or more exemplary embodiments, a fluid monitoring module, such as, for example, any of the modules described herein, may be used in a variety of applications, including, for example, any one or more locations in a process analytical system. Examples include field stations, fast loop systems, grab sampling locations, calibration and switching locations, sample conditioning locations, gas and/or utilities analyzers, and sample disposal locations.

According to another aspect of the present disclosure, a flow sensing device may be configured to facilitate removal of a flow restricting element without removing the flow sensing device from the system, for example, to replace a damaged or contaminated flow restricting element, to facilitate inspection of the flow restricting element, or to replace the flow restricting element with a second flow restricting element providing a different flow condition (e.g., different flow rate). In one such embodiment, the flow sensing element may be provided with first and second end connections facilitating disconnection and removal of the flow sensing element from the inlet/outlet ports and the upstream/downstream sensor ports. As one example, first and second end connections of a flow sensing element may include zero clearance fittings (e.g., gasketed VCO fittings manufactured by Swagelok Co.) facilitating removal and reinstallation/replacement of the flow sensing element without repositioning the ported ends of the flow sensing device.

FIG. **14** illustrates an exemplary fluid monitoring module **600** including a flow sensing device **605** configured to facilitate removal of a flow restricting element **640**. The exemplary flow sensing device **605** includes first and second T-shaped body members **610-1**, **610-2** including first run ports defining laterally outward extending inlet and outlet ports **611**, **612**, second run ports defining laterally inward extending upstream and downstream sensor ports **613**, **614**, and branch or connecting ports defining axially extending first and second restrictor connections **618**, **619** for connecting with first and second end connectors **648**, **649** of the flow restricting element **640**. Upstream and downstream sensors **620**, **630** (which may be similar to the sensors **120**, **130**, **520**, **530** of the embodiments of FIGS. **1-13**) are sealingly installed in the upstream and downstream sensor ports **613**, **614**.

The inlet port **611**, upstream sensor port **613** and first restrictor connection **618** of the first body member **610-1** are connected in fluid communication by an internal T-shaped upstream passage **616** of the first body member **610-1**, and the outlet port **612**, downstream sensor port **614**, and second end connection **619** are connected in fluid communication by an internal T-shaped downstream passage **617** of the second body member **610-2**. The ports may include any suitable fluid system connectors, including, for example, one or more tube fittings, face seal fittings, threaded pipe ends, or weld ends.

The upstream and downstream passages **616**, **617** are connected by a flow restricting passage **615** in the flow restricting element **640**. As described above, the flow restricting passage **615** may take one or more of a variety of forms including, for example, one or more straight or convoluted passages or one or more sintered or other such flow restricting materials. The passage(s) may be formed using one or more of a variety of processes, including machining or additive manufacturing. The flow restricting

passages may be formed in one or more inserts **641** (e.g., plugs, plates, etc.) retained in a coupling body **642** to which the first and second end connections **648**, **649** are attached (e.g., by welding or integrally forming). In one embodiment, the flow restricting insert(s) may be removable from the coupling body for replacement with alternative flow restricting inserts providing different flow rates, flow paths, materials, or other such properties. In other embodiments, the flow restricting component may be integrally or monolithically formed with the coupling body, such that the entire flow restricting element is replaced. In other embodiments, the flow restricting element **640** may be replaced with a flow restricting element having a different axial length, for example, to adjust the offset of the inlet and outlet ports **611**, **612**. In still other embodiments, variations in the offset of the inlet and outlet ports may be accommodated by providing the inlet and outlet ports with flexible end connections, such as, for example, hose connections.

The first and second end connections **648**, **649** of the exemplary flow restricting element **640** include zero clearance connectors for connection with mating zero clearance connectors of the first and second connections **618**, **619** of the first and second body members **610-1**, **610-2**. An exemplary zero clearance fitting is a VCO fitting, manufactured by Swagelok Co. In one embodiment, the coupling body **642** is provided with male threaded body connectors, and the body members **610-1**, **610-2** are provided with welded glands and captured female threaded nuts for coupling with the male threaded body connectors. In another embodiment, the body members **610-1**, **610-2** are provided with male threaded body connectors, and the coupling body **642** is provided with welded glands and captured female threaded nuts for coupling with the captured nuts. In still another embodiment, the coupling body **642** is provided with a male threaded body connector for connecting with a captured female nut on one of the first and second body members, and a captured female threaded nut for connecting with a male threaded body connector on the other of the first and second body members. This arrangement may provide an assurance that the flow restricting element is installed in the correct directional orientation.

The flow restricting element may be provided as a multiple piece subassembly including one or more connectors detachable to facilitate removal and/or replacement of the flow restricting insert from the coupling body. FIG. **14A** illustrates an exemplary flow restricting element **640a** with a two-piece body including a male threaded gland **643a** joined with a female threaded connector **644a** to form the coupling body **642a**. A flow restricting insert **641a**, defining a flow restriction or orifice **615a** is received in a recess in the connector **644a**, and the exemplary gland **643a** includes a face seal O-ring **645a** that seals against the retainer body recess and the insert. The gland **643a** retains a female threaded zero clearance fitting nut **648a** for connecting with a male threaded zero clearance fitting body on a first body member of the flow restricting device, and the retainer body defines a male threaded zero clearance fitting body **649a** for connecting with a female threaded zero clearance fitting nut on a second body member of the flow restricting device. To repair (e.g., clean) or replace the flow restricting insert **641a**, the fitting nut **648a** is unthreaded from the male threaded fitting body of the device (not shown), and the connector **644a** is unthreaded from the female threaded nut of the device (not shown) to remove the flow restricting element subassembly **640a** from the device. The gland **643a** is then unthreaded from the connector **644a** for removal and repair/reinstallation or replacement of the flow restricting insert

641a. Alternatively, the entire flow restriction element subassembly **640a** may be replaced.

FIG. **14B** illustrates another exemplary flow restricting element **640b** having a two-piece body **642b** including a first male threaded zero clearance connector **643b** having a female threaded (e.g., NPT threads) end and a second male threaded zero clearance connector **644b** having a mating male threaded (e.g., NPT threads) end joined with the female threaded end to form the coupling body. A flow restricting insert **641b** defining a flow restricting orifice **615b** is received in a recess in the first connector **643b**, and may be secured against a counterbore portion **645b** of the first connector by an end face **646b** of the male threaded end of the second connector **644b**. To repair (e.g., clean) or replace the flow restricting insert **641b**, the first and second male connectors **643b**, **644b** are unthreaded from corresponding female threaded nuts (not shown) of the device to remove the flow restricting element subassembly **640b** from the device. The first and second male connectors **643b**, **644b** may then be unthreaded from each other for removal and repair/reinstallation or replacement of the flow restricting insert **641b**. Alternatively, the entire flow restriction element subassembly **640b** may be replaced.

FIG. **14C** illustrates an exemplary flow restricting element **640c** with a two-piece arrangement including a male threaded zero clearance connector **643c** joined with a gland **644c** by a female threaded zero clearance nut **648c**. A flow restricting insert **641c**, defining a flow restricting orifice **615c**, is received and sealed between a face seal O-ring **645c** assembled with the male connector **643c** (e.g., retained in an end face groove of the male threaded end) and a face seal O-ring **646c** assembled with the gland **644c** (e.g., retained in an end face groove of the gland). In an exemplary embodiment, the male connector **643c** may be affixed with (e.g., welded to, coupled to, or integrally machined with) a first fitting body defining an first (e.g., inlet, outlet) port and a sensor retaining first (e.g., upstream, downstream) sensor port, and the gland may be affixed with (e.g., welded to, coupled to) a second fitting body defining a second (e.g., inlet, outlet) port and a sensor retaining second (e.g., upstream, downstream) sensor port. To repair (e.g., clean) or replace the flow restricting insert **641c**, the female threaded nut **648c** is unthreaded from the male threaded connector **643c**, and the flow restricting insert **641c** is slid out of engagement from the face seal O-rings **645c**, **646c** for repair/reinstallation or replacement of the flow restricting insert **641c**.

In other embodiments, the flow restricting element may be provided as a single piece body having a flow restriction assembled with or integral with the body. FIG. **14D** illustrates an exemplary flow restricting element **640d** with a single piece body **642d** including first and second male threaded zero clearance connections **648d**, **649d** and a flow restriction **615d** integrally formed along a through bore **647d** (e.g., centrally located, as shown). To repair (e.g., clean) or replace the flow restriction **615d**, the first and second male connections **648d**, **649d** are unthreaded from corresponding female threaded nuts (not shown) of the device to remove the flow restricting element **640d** from the device.

In other embodiments, a flow restricting insert may be assembled with a single piece flow restricting element body, for example, using a threaded engagement, press fit engagement, or retaining clip engagement, and may in some embodiments include a gasket or seal to prevent leakage between the flow restricting element body and an outer periphery of the insert. FIG. **14E** illustrates an exemplary flow restricting element **640e** with a single piece body **642e**

including first and second male threaded zero clearance connections **648e**, **649e** and a press-in orifice disc or apertured insert **641e** (defining orifice **615e**), installed in a through bore **647e** of the body (e.g., seated against a counterbore in the through bore). FIG. **14F** illustrates an exemplary flow restricting element **640f** with a single piece body **642f** including first and second male threaded zero clearance connections **648f**, **649f** and a press-in sintered element or porous insert **641f** installed in a through bore **647f** of the body (e.g., seated against a counterbore in the through bore) to define a porous flow path **615f**. While the flow restricting insert may be positioned in a central portion of the through bore, between the end connections, as shown in FIGS. **14E** and **14F**, in other embodiments, the flow restricting insert may be installed within at least one of the end connections, in an end portion of the through bore. FIG. **14G** illustrates an exemplary flow restricting element **640g** with a single piece body **642g** including first and second male threaded zero clearance connections **648g**, **649g** and a press-in sintered element or porous insert **641g** installed in an end portion of the through bore **647g**, in the first end connection **648g** (e.g., seated against a counterbore in the through bore) to define a porous flow path **615g**. FIG. **14H** illustrates an exemplary flow restricting element **640h** with a single piece body **642h** including first and second male threaded zero clearance connections **648h**, **649h** and a restrictor set screw or threaded apertured insert **641h** (defining orifice **615h**) installed in a female threaded end portion of the through bore **647h**, in the first end connection **648h**. FIG. **14I** illustrates an exemplary flow restricting element **640i** with a single piece body **642i** including first and second male threaded zero clearance connections **648i**, **649i** and an orifice disc or apertured insert **641i** (defining orifice **615i**) installed in an end face counterbore of the through bore **647i**, in the first end connection **648i** (e.g., snap fit or press fit). In one such embodiment, the o-ring seal **645i** of the first end connection **648i** provides a seal between the outer periphery of the orifice disc **641i** and the counterbore.

To repair (e.g., clean) or replace the flow restricting inserts **641e-h**, the first and second male connections **648e-h**, **649e-h** are unthreaded from corresponding female threaded nuts (not shown) of the device to remove the flow restricting element **640e-h** from the device. The insert **641e-h** may be removed (e.g., unthreaded, pressed) from the body **642e-h** for cleaning or replacement. Alternatively, the entire flow restricting element **640e-h** may be replaced.

Referring back to FIG. **14**, the exemplary fluid monitoring module **600** includes an enclosure (shown schematically at **601**) affixed to (e.g., at least partially enclosing) the flow sensing device **605** and enclosing a controller, shown schematically at **650** (which may be similar to the controller **550** of the embodiments of FIGS. **10A-13C**). The sensors **620**, **630** are connected (e.g., by wiring within the module enclosure) to the controller **650** to transmit pressure and temperature indicating signals to the controller. The controller **650** is configured to process the pressure and temperature indicating signals, for example, to determine pressure, temperature, and/or flow rate of fluid passing through the flow sensing device, and/or to provide a measured output of any one or more of these parameters. Similar to the exemplary embodiment of FIGS. **10A-13C**, the module **600** may additionally be provided with one or more of: one or more internal batteries **660**; a wireless transmitter (e.g., provided on a circuit board of the controller **650**) for wirelessly transmitting fluid data to a remote device; an external antenna **655**, electrically connected with the controller transmitter, for enhanced wireless communication with a remote device; a

user interface, such as, for example, one or more knobs, switches or buttons, for example, to turn on the controller, to turn off the controller, or to commission/synchronize the controller, and one or more display elements (e.g. indicator LEDs and/or display screen), as described in greater detail above.

The enclosure **601** may be provided with a cover or lid (not shown) to selectively enclose the flow sensing device **605**, while being movable or removable for exposure of the flow sensing device, for example, to facilitate removal and/or replacement of the flow restricting element.

Still other arrangements may be utilized to facilitate removal and/or replacement of a flow restricting element from a flow sensing device. FIG. **15** schematically illustrates a fluid monitoring module **700** including a flow sensing device **705** having first and second T-shaped body members **710a**, **710b** including first run ports defining laterally outward extending inlet and outlet ports **711**, **712**, second run ports defining laterally inward extending upstream and downstream sensor ports **713**, **714** (retaining upstream and downstream sensors **720**, **730**), and branch ports defining laterally extending first and second connections **718**, **719**, perpendicular to the inlet/outlet and sensor ports **711**, **712** (i.e., extending outward from the drawing sheet), **713**, **714**, for connecting with first and second end laterally extending connectors **748**, **749** of a U-shaped flow restricting element **740**. The U-shaped flow restricting element **740** includes an axially extending portion defining one or more flow restricting passages **715**, which may be formed, for example, in one or more inserts **741** (e.g., plugs, plates, etc.) retained in a U-shaped coupling body **742** to which the first and second end connections **748**, **749** are attached (e.g., by welding or integrally forming). The coupling body **742** may be provided as a multiple piece assembly including one or more connectors **744** detachable to facilitate removal and/or replacement of the insert **741** from the coupling body. In one embodiment, the flow restricting insert(s) may be removable from the coupling body for replacement with alternative flow restricting inserts providing different flow rates, flow paths, materials, or other such properties. In other embodiments, the flow restricting component may be integrally or monolithically formed with the coupling body, such that the entire flow restricting element is replaced.

The U-shaped configuration of the flow restricting element **740** may facilitate removal from the flow sensing device **705** and may facilitate the use of end connections that are not zero-clearance connections (e.g., fittings that do not use elastomeric seals, for example, to allow for a wider range of system conditions), including, for example, tube fittings, quick disconnect fittings, and push-to-connect fittings.

According to another aspect of the present disclosure, a fluid monitoring module may be provided with a flow sensing device arranged such that at least a flow restricting element of the flow sensing device is external to a housing of the fluid monitoring module, for example, to facilitate removal of the flow restricting element without removing, disassembling, or otherwise adjusting the module housing. As one example, as shown in FIG. **16A**, a fluid monitoring module **400a** may be provided with a flow sensing device **405a** having first (e.g., upstream) and second (e.g., downstream) sensor ports **413a**, **414a** mounted to the module enclosure **401a** for electrical connection of retained sensors (which may be similar to the sensors **120**, **130**, **520**, **530** of the embodiments of FIGS. **1-13C**) to a controller enclosed within the module enclosure **401a**, such that the flow restricting element **440a** (e.g., any of the exemplary flow

restricting elements **640a-i** of FIGS. **14A-I**) is disposed external to the module enclosure **401a**, for example, to facilitate removal and replacement/repair of the flow restricting element **440a**.

In the embodiment of FIG. **16A**, the flow sensing device **405a** includes first and second T-shaped body members **410a-1**, **410a-2** including first run ports defining laterally outward extending inlet and outlet ports **411a**, **412a**, second run ports defining the laterally inward extending sensor ports **413a**, **414a**, and branch or connecting ports defining axially extending first and second restrictor connections **418a**, **419a** for connecting with the flow restricting element **440a**. As described above, the restrictor connections **418a**, **419a** may be zero-clearance connections to facilitate removal of the flow restricting element **440a**.

In another exemplary arrangement, as shown in FIG. **16B**, a fluid monitoring module **400b** includes an externally mounted flow sensing device **405b** having first and second T-shaped body members **410b-1**, **410b-2** including first run ports defining axially extending inlet and outlet ports **411b**, **412b**, second run ports defining axially extending first and second restrictor connections **418b**, **419b** for connecting with the flow restricting element **440b** (e.g., any of the exemplary flow restricting elements **640a-i** of FIGS. **14A-I**), and branch or connecting ports defining laterally inward extending sensor ports **413b**, **414b** mounted to the module enclosure **401b** for electrical connection of the retained sensors (which may be similar to the sensors **120**, **130**, **520**, **530** of the embodiments of FIGS. **1-13C**) to a controller enclosed within the module enclosure **401b**.

In another exemplary arrangement, as shown in FIG. **16C**, a fluid monitoring module **400c** includes an externally mounted flow sensing device **405c** having first and second T-shaped body members **410c-1**, **410c-2** including first run ports defining laterally outward extending inlet and outlet ports **411c**, **412c**, second run ports defining laterally inward extending first and second (e.g., upstream and downstream) sensor ports **413c**, **414c** mounted to the module enclosure **401c** for electrical connection of the retained sensors (which may be similar to the sensors **120**, **130**, **520**, **530** of the embodiments of FIGS. **1-13C**) to a controller enclosed within the module enclosure **401c**, and branch ports defining perpendicular laterally extending first and second restrictor connections **418c**, **419c** for connecting with a U-bend flow restricting element **440c** (which may be similar to the flow restricting element **740** of FIG. **15**).

Many different arrangements may be utilized to mount the sensor ports of the flow sensing device to the module enclosure. FIG. **17** illustrates an exemplary arrangement including a flow sensing device body member **410'** including a male threaded sensor port or connector **413'** received through a mounting aperture **408'** in the module enclosure **401'** and secured against the module enclosure by a panel nut **481'** threaded with the male connector **413'**. A sensor **420'** is installed in the sensor port connector **413'** and is secured against a counterbore **483'** by a retaining collar **485'** extending through the sensor port **413'** to engage a surface of the sensor **420'**. A fitting nut **487'** is threadably assembled with the male connector **413'** to secure an end portion **486'** of the retaining collar **485'**, and a wire connector **489'** (e.g., M8 connector) is installed in a central bore in the retaining collar end portion **486'** to provide a connection between wiring **423'** from the sensor **420'** and the controller (not shown). Gasket seals **482'**, **484'**, **488'** (e.g., O-ring seals) may be provided between the body member **410'** and module enclosure **401'**, between the retaining collar **485'** and male connector **413'**, and between the male connector **413'** and wire

connector **489'**, for example, to seal the module enclosure **401'** from moisture or other contamination. A gasket seal **422'** (e.g., O-ring seal) around the sensor **420'** provides a leak tight seal to prevent system fluid leakage past the sensor **420'**.

In other exemplary arrangements, as illustrated, for example, in FIG. **16D**, a fluid monitoring module **400d** may be provided with a flow sensing device **405d** having a first body member **410d-1** with a first (e.g., upstream) sensor port **413d** mounted to the module enclosure **401d** (e.g., using the arrangement of FIG. **17**) for electrical connection of a retained sensor (e.g., as described above) to a controller enclosed within the module enclosure **401d**, and a second body member **410d-2** with a second (e.g., downstream) sensor ports **414d** spaced apart from the module enclosure and retaining a sensor (e.g., as described above) electrically connected (e.g., by flexible wiring **452d** extending from the second sensor port **414d** to the module enclosure **401d**) to a controller enclosed within the module enclosure **401d**, such that the flow restricting element **440d** is disposed external to the module enclosure **401d**, for example, to facilitate removal and replacement/repair of the flow restricting element **440d**. The single sensor port mount arrangement may allow for use of different sized flow restricting elements (e.g., different offset dimensions between the sensor ports, different lengths of flow restrictions) and/or different sized module enclosures. Additionally, the single sensor port mount arrangement may facilitate removal of the flow restricting element **440d** from the flow sensing device **405d** without using zero clearance connections (e.g., to eliminate polymeric seals in the connections), as the second sensor port is not fixedly mounted.

In still other exemplary arrangements, as illustrated, for example, in FIG. **16E**, a fluid monitoring module **400e** may be provided with a flow sensing device **405e** having first and second body members **410e-1**, **410e-2** defining inlet and outlet ports **411e**, **412e**, and first and second (e.g., upstream and downstream) sensor ports **413e**, **414e** spaced apart from the module enclosure **401e** and retaining sensors (e.g., as described above) electrically connected (e.g., by flexible wiring **451e**, **452e** extending from the first and second sensor ports **413e**, **414e** to the module enclosure **401e**) to a controller enclosed within the module enclosure **401e**, such that the flow restricting element **440e** is disposed external to the module enclosure **401e**, for example, to facilitate removal and replacement/repair of the flow restricting element **440e**. The detached or remote, wire connected sensor port arrangement may allow for use of different sized flow restricting elements (e.g., different offset dimensions between the sensor ports, different lengths of flow restrictions) and/or different sized module enclosures. Additionally, the wire connected sensor port arrangement may facilitate removal of the flow restricting element **440e** from the flow sensing device **405e** without using zero clearance connections (e.g., to eliminate polymeric seals in the connections), as the sensor ports are not fixedly mounted and thus easily moveable with respect to each other. Additionally, in one such configuration, the module **400e** may be configured to easily disconnect from the sensor wiring **451e**, **452e**, for example, to allow use of the monitoring module with multiple flow sensing devices or to perform maintenance on the monitoring module.

According to another aspect of the present disclosure, a fluid monitoring module may be configured or adapted to provide separate sensing of fluid conditions in multiple fluid lines, or at multiple locations in a single fluid line, for example, to monitor changes in pressure over time (e.g., as

an indication of filter or fluid line contamination). In one such arrangement, the flow restriction may be eliminated, with the flow sensing arrangement providing separate sensor engaging flow paths. As one example, as shown in FIG. 18A, a fluid monitoring module **300a** may be provided with separate first and second sensing devices **305a-1**, **305a-2** having first and second (e.g., inlet and outlet) ports **311a-1**, **311a-2**, **312a-1**, **312a-2** and first and second sensor ports **313a-1**, **313a-2** mounted to the module enclosure **301a** for electrical connection of retained sensors (as described above) to a controller enclosed within the module enclosure **301a**.

As another example, a fluid monitoring module with an external flow restricting element may be converted to a fluid monitoring module having separate fluid sensing devices by separating the flow restriction with one or more blind or blank coupling members. FIG. 18B illustrates an exemplary fluid monitoring module **300b**, similar to the fluid monitoring module **400a** of FIG. 16A, except with the flow restricting element replaced with a fluid blocking blind or blank coupling **340b** installed between connections **318b**, **319b** of first and second body members **310b-1**, **310b-2**, to provide two separate dead-leg fluid monitoring locations. Alternatively (not shown), separate plugs may be assembled to the opposed body member connections.

FIG. 18C illustrates an exemplary fluid monitoring module **300c** including first and second cross-shaped flow sensing bodies **310c-1**, **310c-2**, with sensor ports **313c**, **314c** mounted to the module enclosure **301c**, first, axially outward extending ports **311c-1**, **311c-2**, second, laterally outward extending ports **312c-1**, **312c-2**, and axially inward extending restrictor connections **318c**, **319c**. To use the monitoring module **300c** to monitor flow rate, a flow restricting element (e.g., any of the flow restricting elements **440a-h** of FIGS. 14A-14I) may be assembled with the restrictor connections **318c**, **319c**, one of the ports **311c-1**, **312c-1** of the first flow sensing body **310c-1** may be connected with a fluid inlet line, one of the ports **311c-2**, **312c-2** of the second flow sensing body **310c-2** may be connected with a fluid outlet line, and the two unused ports may be plugged. To use the monitoring module **300c** to monitor two separate fluid locations, a blank or blind coupling **340c** (as shown, for example, in FIG. 18D) or blank/blind insert **341c** (as shown, for example, in FIG. 18E) may be assembled with the restrictor connections **318c**, **319c**, one of the ports **311c-1**, **312c-1**, **311c-2**, **312c-2** of each of the first and second flow sensing bodies **310c-1**, **310c-2** may be connected with first and second fluid inlet lines, and the others of the ports of each of the first and second flow sensing bodies **310c-1**, **310c-2** may be connected with first and second fluid outlet lines.

According to another aspect of the present disclosure, a fluid monitoring module may be configured to be provided as a separate, portable device that may be configured to be selectively connected to a fluid line for measurement of flow, temperature, and/or pressure conditions, thereby allowing for use of a single fluid monitoring module for multiple fluid lines.

FIG. 19 illustrates an exemplary system including a fluid line L with an engineered flow restriction R (e.g., provided in a flow restricting coupling, valve, etc.), and a fluid monitoring module **800**. The fluid line L includes branch connectors **C1**, **C2** (e.g., quick disconnect couplings) upstream and downstream of the flow restriction R, for connection with sensor port connectors **811**, **812** of upstream and downstream sensor ports **813**, **814** (e.g., using mating quick disconnect couplings) of the fluid monitoring module

800. Upstream and downstream sensors **820**, **830** (which may be similar to the sensors described above) are sealingly installed in the upstream and downstream sensor ports **813**, **814**, and are electrically connected to a controller **850** disposed in an enclosure **801** of the fluid monitoring module **800**. Similar to the exemplary embodiments of FIGS. 10A-13C, the module **800** may additionally be provided with one or more of: one or more internal batteries; a wireless transmitter (e.g., provided on a circuit board of the controller **850**) for wirelessly transmitting flow data to a remote device; an external antenna, electrically connected with the controller transmitter, for enhanced wireless communication with a remote device; a user interface, such as, for example, one or more knobs, switches or buttons, for example, to turn on the controller, to turn off the controller, or to commission/synchronize the controller, and one or more display elements (e.g. indicator LEDs and/or display screen), as described in greater detail above.

To monitor the flow conditions of the fluid line L, the upstream sensor port connector **811** is connected with the upstream fluid line branch connector **C1** for measuring the pressure and/or temperature upstream of the flow restriction R, and the downstream sensor port connector **812** is connected with the downstream fluid line branch connector **C2** for measuring the pressure and/or temperature downstream of the flow restriction R. Corresponding signals are transmitted from the sensors **820**, **830** to the controller **850** for calculation and identification (e.g., through a user interface or communication of the data to a remote computer) of the pressure, temperature, flow rate, and/or other fluid conditions.

In another embodiment, a fluid monitoring module may be configured to measure only pressure and temperature of a fluid, and not flow rate. In such an arrangement, the module may be provided with a single sensor port and sensor. FIG. 20 illustrates an exemplary system including a fluid line L and a fluid monitoring module **900**. The fluid line L includes a branch connector C (e.g., a quick disconnect coupling) for connection with a sensor port connector **911** of a sensor port **913** (e.g., using mating quick disconnect couplings) of the fluid monitoring module **900**. A sensor **920** (which may be similar to the sensors described above) is sealingly installed in the sensor port **913** and is electrically connected to a controller **950** disposed in an enclosure **901** of the fluid monitoring module **900**. Similar to the exemplary embodiments of FIGS. 10A-13C, the module **900** may additionally be provided with one or more of: one or more internal batteries; a wireless transmitter (e.g., provided on a circuit board of the controller **950**) for wirelessly transmitting fluid data to a remote device; an external antenna, electrically connected with the controller transmitter, for enhanced wireless communication with a remote device; a user interface, such as, for example, one or more knobs, switches or buttons, for example, to turn on the controller, to turn off the controller, or to commission/synchronize the controller, and one or more display elements (e.g. indicator LEDs and/or display screen), as described in greater detail above. In another application, the single sensor monitoring module **900** may be used to sequentially measure pressure at an upstream branch connector **C1** and at a downstream branch connector **C2** (see FIG. 16) to sequentially measure pressure upstream and downstream of an engineered flow restriction R in the fluid line L, thereby enabling the controller **950** to calculate a flow rate in the fluid line by using only one sensor.

In another embodiment, a portable, selectively connectable fluid monitoring module may include a bypass flow

path with a flow restricting passage between upstream and downstream sensor ports, thereby allowing for the elimination of the flow restriction from the fluid line, for example, to minimize contamination or erosion of the flow restriction.

FIG. 21 illustrates an exemplary system including a fluid line L and a fluid monitoring module 1000. The fluid line L includes upstream and downstream branch connectors C1, C2 (e.g., quick disconnect couplings) for connection with inlet and outlet connectors 1011, 1012 (e.g., mating quick disconnect couplings) of the module 1000. The module 1000 further includes an upstream sensor port 1013 connected to the inlet connector 1011 by an upstream passage 1016, and a downstream sensor port 1014 connected to the outlet connector 1012 by a downstream passage 1017. Upstream and downstream sensors 1020, 1030 (which may be similar to the sensors described above) are sealingly installed in the upstream and downstream sensor ports 1013, 1014 and electrically connected to a controller 1050 disposed in an enclosure 1001 of the fluid monitoring module 1000. The upstream and downstream passages 1016, 1017 are connected by a flow restricting passage 1015. The inlet and outlet connectors 1011, 1012, upstream and downstream sensor ports 1013, 1014, internal passages 1016, 1017, and flow restricting passage 1015 may be provided in a flow sensing device 1005 assembled with the module enclosure 1001, as shown in the many exemplary embodiments described herein.

Similar to the exemplary embodiment of FIGS. 10A-13C, the module 1000 may additionally be provided with one or more of: one or more internal batteries; a wireless transmitter (e.g., provided on a circuit board of the controller 1050) for wirelessly transmitting flow data to a remote device; an external antenna, electrically connected with the controller transmitter, for enhanced wireless communication with a remote device; a user interface, such as, for example, one or more knobs, switches or buttons, for example, to turn on the controller, to turn off the controller, or to commission/synchronize the controller, and one or more display elements (e.g. indicator LEDs and/or display screen), as described in greater detail above.

To monitor the flow conditions of the fluid line L, the inlet connector 1011 of the module is connected with the upstream fluid line branch connector C1 and the outlet connector 1012 is connected with the downstream fluid line branch connector C2. A shutoff valve V may be disposed in the fluid line L between the upstream and downstream branch connectors C1, C2, and may be shut off to bypass all fluid line flow through the fluid monitoring module 1000. Alternatively, switching valves (shown in phantom at V1, V2) may be used to divert fluid flow from the fluid line L through the fluid monitoring module 1000. The upstream sensor 1020 measures the pressure and/or temperature upstream of the flow restricting passage 1015, and the downstream sensor 1030 measures the pressure and/or temperature downstream of the flow restricting passage 1015. Corresponding signals are transmitted from the sensors 1020, 1030 to the controller 1050 for calculation and identification (e.g., through a user interface or communication of the data to a remote computer) of the pressure, temperature, flow rate, and/or other fluid conditions.

In still another embodiment, a portable fluid monitoring module may be provided without fluid components (e.g., ports, connectors, passages), and with a wireless transceiver for communicating wirelessly with one or more fluid sensors integrated into the fluid line of a system, such that an operator may perform a fluid monitoring operation at one or

more locations in a fluid system by bringing the portable fluid monitoring module into proximity with the integrated fluid sensor(s).

FIG. 22 illustrates an exemplary system including a fluid line L with an engineered flow restriction R (e.g., provided in a flow restricting coupling, valve, etc.), and a portable fluid monitoring module 1400. The fluid line L includes fluid sensors 1420, 1430 (which may be similar to the sensors described above) upstream and downstream of a flow restriction 1415. While the fluid sensors 1420, 1430 and flow restriction 1415 may be integrated into the fluid line L, in an exemplary embodiment, the fluid sensors and flow restriction may be provided in a separate flow sensing device 1405 including connectors 1411, 1412 (e.g., zero clearance fittings) configured to facilitate coupling and decoupling from the fluid line L. The flow restriction 1415 may be provided in a flow restricting element 1440 having connectors 1448, 1449 to facilitate removal of the flow restricting element from the flow sensing device 1405 (e.g., for maintenance or replacement with a different flow restricting element having different sizing and/or flow characteristics).

The fluid monitoring module 1400 includes a transceiver 1470 configured to wirelessly communicate (e.g., RFID, Bluetooth, NFC, or other such wireless communication), for example, through an antenna 1475, with the fluid sensors 1420, 1430, when the fluid monitoring module 1400 is in proximity with the sensors 1420, 1430. Wireless communication may be automatically initiated when in proximity (e.g., as a result of periodic query or ping transmissions by the transceiver), or by actuation of a button or other such user interface. The transceiver 1470 communicates received data signals corresponding to the fluid system (e.g., identification codes, upstream/downstream pressure, temperature, time stamp) to a controller 1450 in the module enclosure 1401. Similar to the exemplary embodiment of FIGS. 10A-13C, the module 1400 may additionally be provided with one or more of: one or more internal batteries 1460; a wireless transmitter (e.g., provided on a circuit board of the controller 1450) for wirelessly transmitting flow data to a remote device; an external antenna 1455, electrically connected with the controller transmitter, for enhanced wireless communication with a remote device; a user interface, such as, for example, one or more knobs, switches or buttons, for example, to turn on the controller, to turn off the controller, or to commission/synchronize the controller, and one or more display elements (e.g. indicator LEDs and/or display screen), as described in greater detail above.

In one embodiment, the fluid monitoring module 1400 may be a smart phone or other such portable computing device that may be provided with a software or web-based application configured to initiate communication with the sensors 1420, 1430, process the received data signals, display data related to the fluid system conditions, and/or transmit fluid data to a remote system.

According to another aspect of the present disclosure, a fluid monitoring module having a controller configured for communicating with an external device may be further configured to receive data transmissions from other proximate fluid system components for communication of properties and characteristics of these proximate fluid system components to an external device for tracking or monitoring. As one example, a portable sample cylinder selectively connected to a fluid system (e.g., for obtaining a grab sample for off-site laboratory analysis) may include communication circuitry (e.g., RFID tag) configured to communicate directly or indirectly with a fluid monitoring module of the fluid system when the sample cylinder is proximate to the

fluid monitoring module. In one example, the fluid monitoring module may include or be connected with (e.g., by a wired or wireless connection) an RFID reader configured to initiate wireless communication (e.g., near field communication, Bluetooth® communication, or other such short range wired or wireless communication) with an RFID tag or transmitter provided with the sample cylinder when the sample cylinder is brought into range of the fluid monitoring module (e.g., by responding to a periodic query or ping from the reader). In other embodiments, communication between the RFID tag/transmitter and the RFID reader may be initiated by a user operated push button switch, or by a switch that is automatically activated when the sample cylinder is connected to the fluid system or when a valve is opened to fill the cylinder.

FIG. 23 schematically illustrates an exemplary system including a fluid line L with which a fluid monitoring module 1300 (e.g., any of the fluid monitoring modules described herein) is installed. The fluid line L includes a branch connector C to which a sample cylinder 1370 may be connected (e.g., by a quick disconnect coupling connection), for example, for obtaining a grab sample of the fluid in the fluid line. The sample cylinder 1370 includes an RFID tag/transmitter 1375 for communicating data regarding the sample cylinder (e.g., serial/ID number, time stamp associated with time of connection to fluid line L) to an RFID reader 1380 provided with or connected to the fluid monitoring module 1300. The data received by the RFID reader 1380 may be communicated to the controller 1350 of the module 1300 (e.g., by a wired or wireless connection between the controller and the RFID reader) and compiled with other contemporaneous fluid system data collected by the controller (e.g., flow rate, pressure, temperature of fluid in the fluid line as measured by sensors 1320, 1330, serial/ID number of the module 1300), and wirelessly communicated via transmitter antenna 1355 to an external device, for example, via a wireless gateway 1390, as powered, for example, by module battery 1360. Such an arrangement allows for real time tracking of a grab sampling operation without providing separate power and wireless transmission capability to the grab sample arrangement, by using the fluid monitoring module as a hub for such data collection and wireless communication.

In other applications, other data may be collected and communicated via the fluid monitoring modules. For example, operator identification data (e.g., as collected from a user ID RFID tag) and an associated timestamp may be transmitted to the controller when one or more operations are performed, such as, for example, grab sampling, maintenance, system shutoff, etc.

The inventive aspects have been described with reference to the exemplary embodiments. Modification and alterations will occur to others upon a reading and understanding of this specification. It is intended to include all such modifications and alterations insofar as they come within the scope of the appended claims or the equivalents thereof

We claim:

1. A flow sensing device comprising:
 - a first body member defining an inlet port, an upstream sensor port, and a first connecting port;
 - a second body member defining an outlet port, a downstream sensor port, and a second connecting port;
 - a flow restricting element defining a flow restricting passage and including a first end connection coupled to the first connecting port and a second end connection coupled to the second connecting port, such that the flow restricting passage is disposed between the inlet

- port and the outlet port, and between the upstream sensor port and the downstream sensor port;
- a first fluid sensor assembled with the upstream sensor port; and

- a second fluid sensor assembled with the downstream sensor port;

wherein the first and second end connections comprise zero clearance connectors that provide for removal and reinstallation of the flow restricting element with the first and second body members without movement of the first and second connecting ports, the zero clearance connectors each including a male threaded connector having an end face groove retaining an O-ring seal.

2. The flow sensing device of claim 1, wherein the flow restricting passage is configured to provide laminar flow.

3. The flow sensing device of claim 1, wherein the first and second end connections comprise O-ring face seal fittings.

4. The flow sensing device module of claim 1, wherein the first and second connecting ports extend laterally from the first and second body members in a first direction, and the flow restricting element is substantially U-shaped.

5. The flow sensing device of claim 1, wherein the flow restricting element comprises at least a first coupling member defining at least one of the first and second end connections.

6. The flow sensing device of claim 5, wherein the flow restricting passage is integrally formed in the first coupling member.

7. The flow sensing device of claim 5, wherein the flow restricting passage is defined by a flow restricting insert assembled with the first coupling member.

8. The flow sensing device of claim 7, wherein the flow restricting insert is disposed in a through bore between the first and second end connections.

9. The flow sensing device of claim 7, wherein the flow restricting insert comprises an apertured plate.

10. The flow sensing device of claim 7, wherein the flow restricting insert comprises a threaded apertured insert installed in a female threaded portion of the first coupling member.

11. The flow sensing device of claim 7, wherein the flow restricting insert is disposed in one of the first and second end connections.

12. The flow sensing device of claim 5, further comprising a second coupling member joined with the first coupling member and defining the other of the first and second end connections.

13. The flow sensing device of claim 12, wherein the flow restricting passage is defined by a flow restricting insert captured between the first and second coupling members.

14. A fluid monitoring module comprising:

a flow sensing device including:

- a first T-shaped body member defining a laterally extending inlet end port, a laterally extending upstream sensor end port, and an axially extending first connecting end port;

- a second T-shaped body member defining a laterally extending outlet end port, a laterally extending downstream sensor end port, and an axially extending second connecting end port;

- a flow restricting element defining a flow restricting passage and including a first end connection coupled to the first connecting end port and a second end connection coupled to the second connecting end port, such that the flow restricting passage is disposed between the inlet end port and the outlet end

25

port, and between the upstream sensor end port and the downstream sensor end port;
 a first fluid sensor disposed within the upstream sensor end port; and
 a second fluid sensor disposed within the downstream sensor end port; and
 a controller in circuit communication with the first and second fluid sensors for receiving at least one of pressure indicating signals and temperature indicating signals from each of the first and second fluid sensors, and for measuring fluid data based on the received signals;
 wherein the first and second end connections comprise zero clearance connectors that provide for removal and reinstallation of the flow restricting element with the first and second body members without repositioning the first and second connecting end ports.
15. The fluid monitoring module of claim **14**, further comprising a wireless transmitter for wirelessly communicating the fluid data from the controller to a remote device.
16. The fluid monitoring module of claim **14**, wherein the fluid data comprises at least one of fluid pressure, fluid temperature and fluid flow rate.
17. A fluid monitoring module comprising an enclosure;
 a fluid sensing device assembled with the enclosure, the fluid sensing device including:
 a first body member defining a first end port, a first sensor port, and a first connecting port;

26

a second body member defining a second end port, a second sensor port, and a second connecting port;
 a first fluid sensor assembled with the first sensor port; and
 a second fluid sensor assembled with the second sensor port;
 and
 a controller disposed within the enclosure and in circuit communication with the first and second fluid sensors for receiving at least one of pressure indicating signals and temperature indicating signals from each of the first and second fluid sensors, and for measuring fluid data based on the received signals;
 wherein the first and second sensor ports extend laterally inward through first and second mounting apertures in the enclosure, such that the first and second sensor ports are disposed within the enclosure and the first end port, the second end port, the first connecting port, and the second connecting port are external to the enclosure.
18. The fluid monitoring module of claim **17**, further comprising a flow restricting element defining a flow restricting passage and including a first end connection coupled to the first connecting port and a second end connection coupled to the second connecting port.
19. The fluid monitoring module of claim **17**, further comprising at least one blind coupling assembled with the first and second connecting ports to provide two separate dead-leg fluid monitoring locations at the first and second end ports.

* * * * *