



US 20200197235A1

(19) **United States**

(12) **Patent Application Publication**
Morimoto et al.

(10) **Pub. No.: US 2020/0197235 A1**

(43) **Pub. Date: Jun. 25, 2020**

(54) **WEARABLE ARTICLE HAVING ELASTIC BELT**

072189, filed on Feb. 4, 2015, which is a continuation-in-part of application No. PCT/CN2014/085251, filed on Aug. 27, 2014.

(71) Applicant: **The Procter & Gamble Company,**
Cincinnati, OH (US)

Publication Classification

(72) Inventors: **Koichi Morimoto,** Beijing (CN); **Ling Tong,** Beijing (CN); **Chunmin Cheng,** Beijing (CN)

(51) **Int. Cl.**
A61F 13/49 (2006.01)
A61F 13/496 (2006.01)

(21) Appl. No.: **16/806,220**

(52) **U.S. Cl.**
CPC .. *A61F 13/49012* (2013.01); *A61F 13/49061* (2013.01); *A61F 13/496* (2013.01); *A61F 13/49015* (2013.01); *A61F 2013/49036* (2013.01); *A61F 13/49011* (2013.01); *A61F 2013/49026* (2013.01); *A61F 2013/49028* (2013.01); *A61F 2013/49041* (2013.01); *A61F 13/4963* (2013.01)

(22) Filed: **Mar. 2, 2020**

Related U.S. Application Data

(63) Continuation of application No. 15/443,011, filed on Feb. 27, 2017, now Pat. No. 10,624,799, which is a continuation of application No. PCT/CN2015/

(57) **ABSTRACT**

The present disclosure relates to wearable articles having an elastic belt having arrays of elastic bodies.

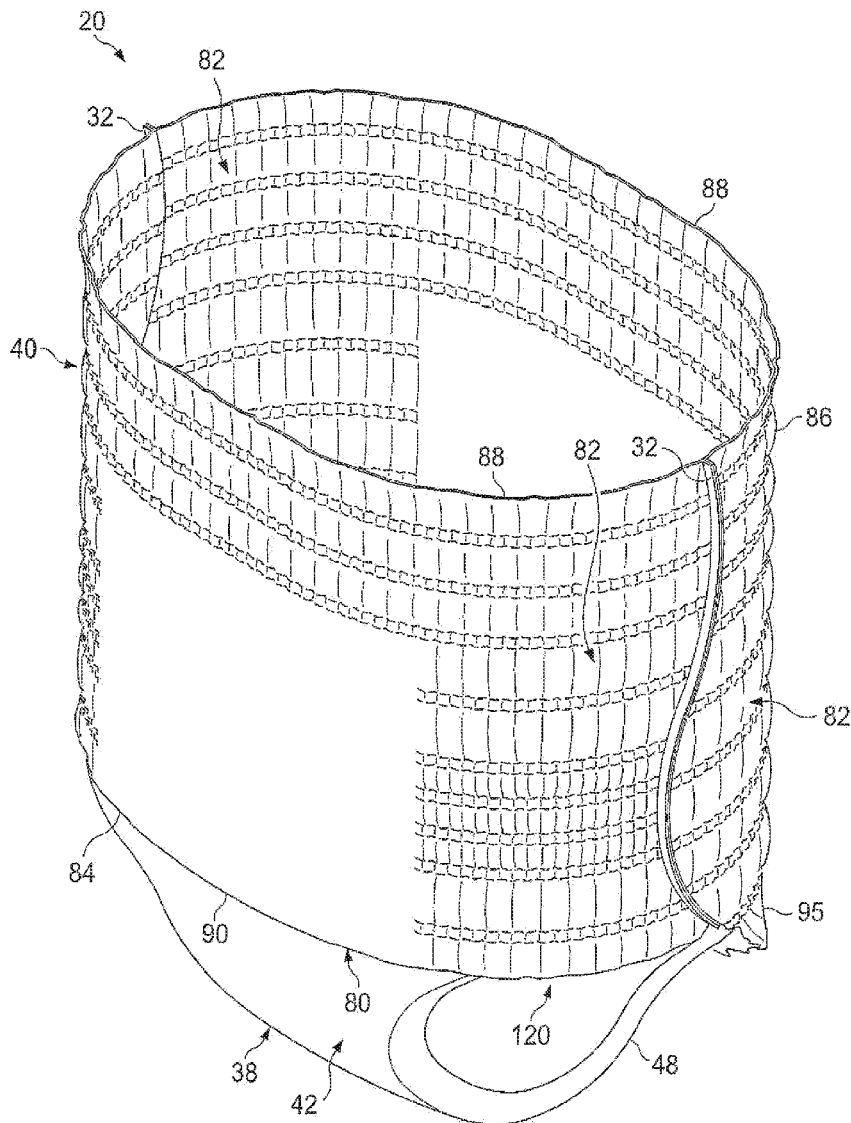

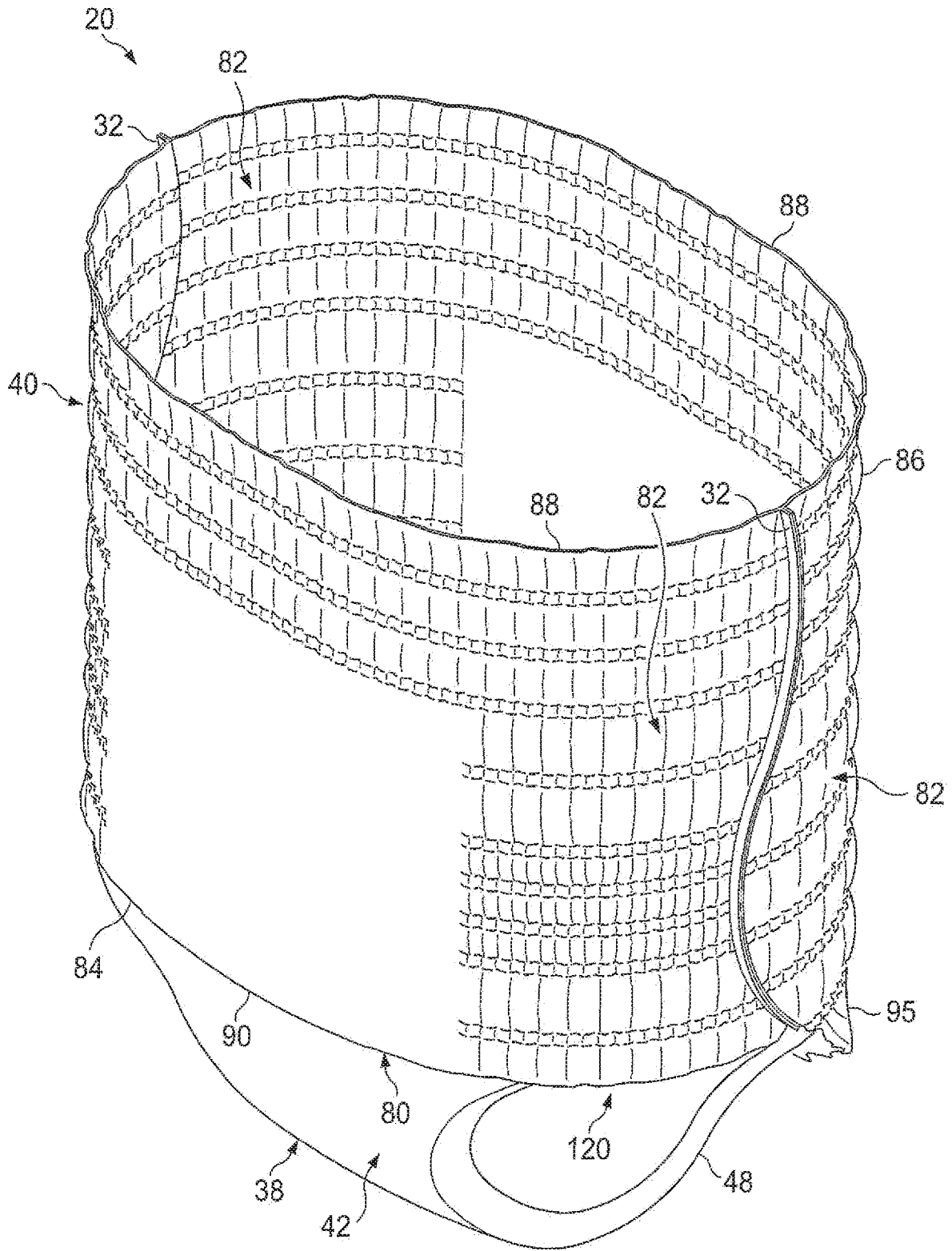

FIG. 1

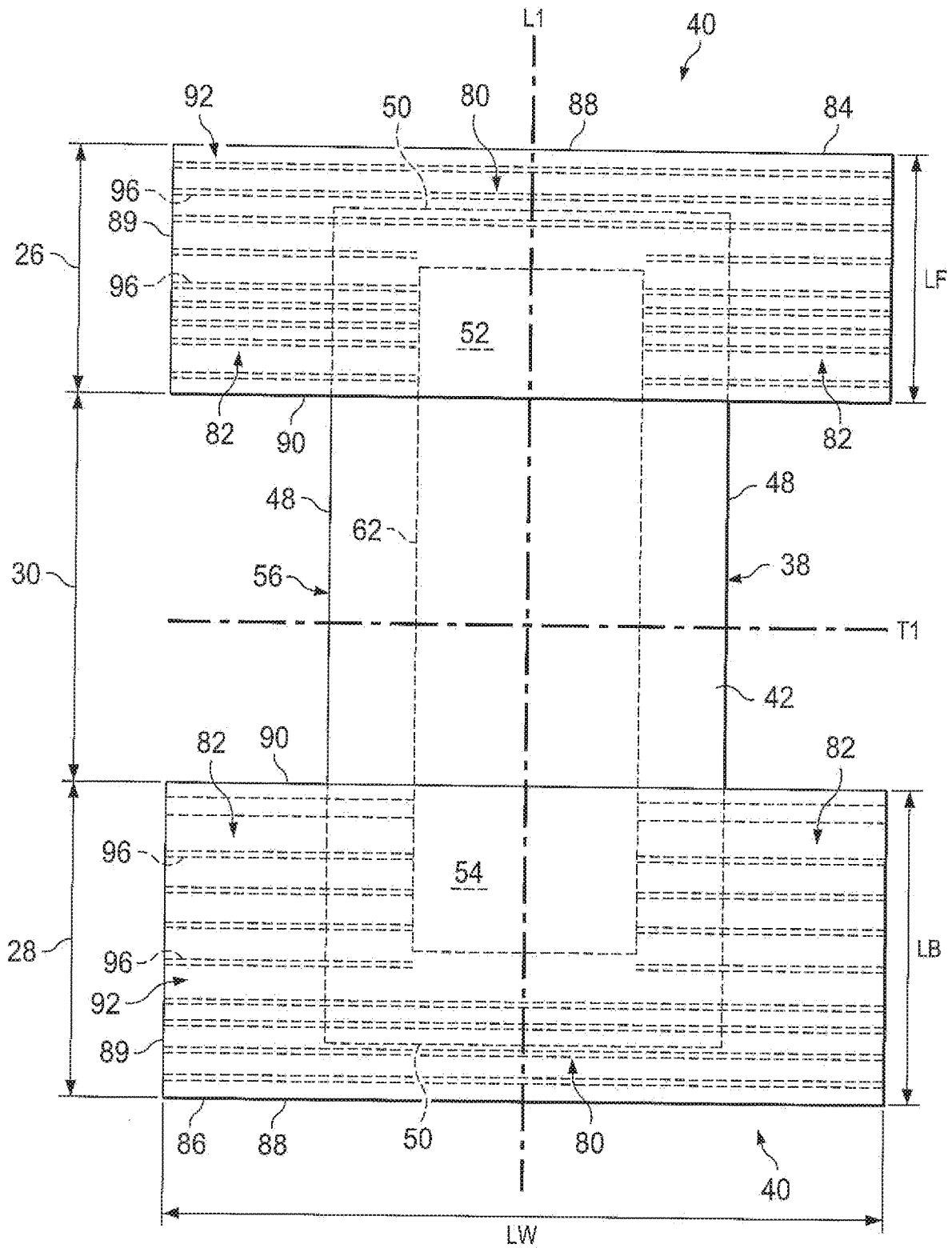

FIG. 2

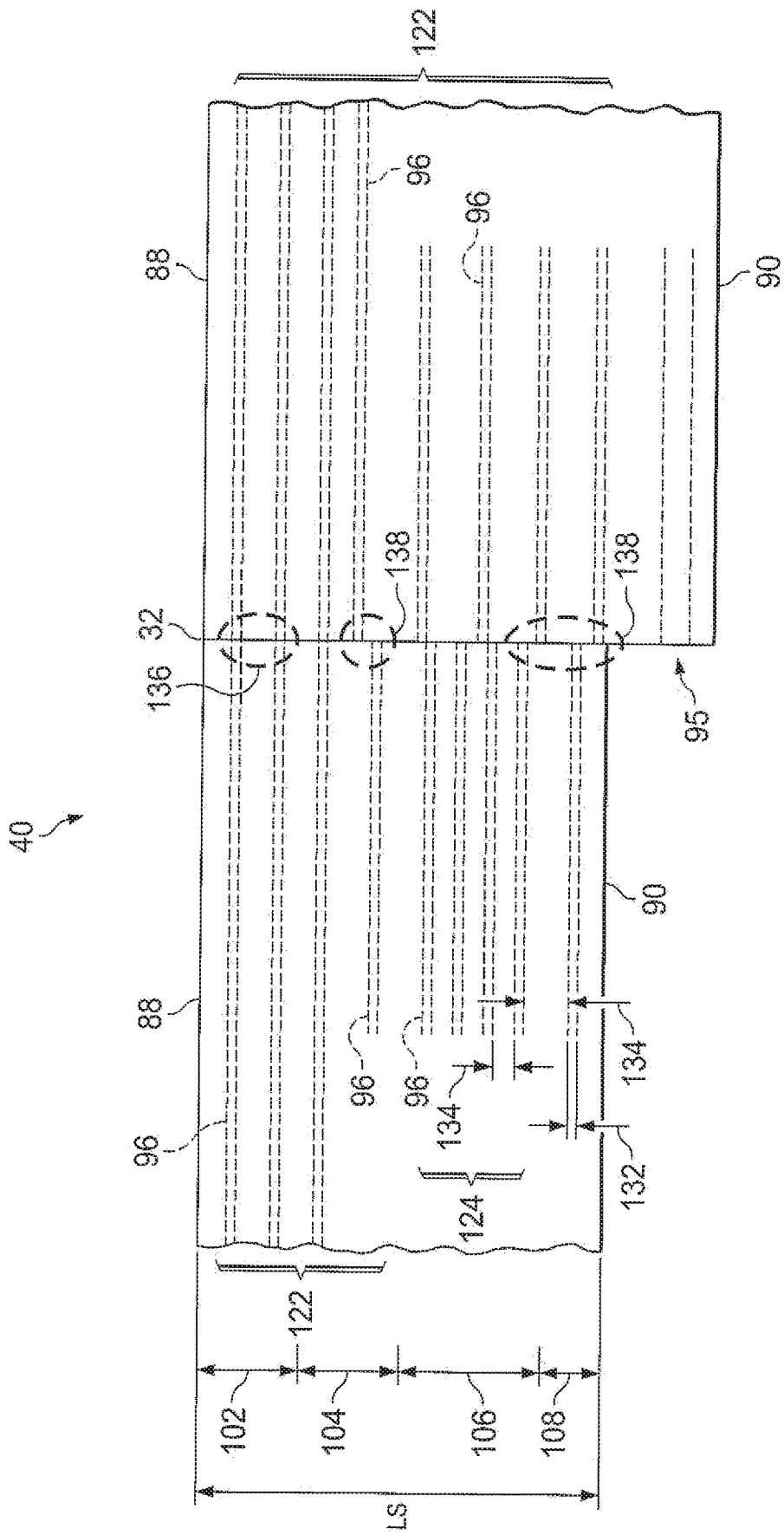

FIG. 3

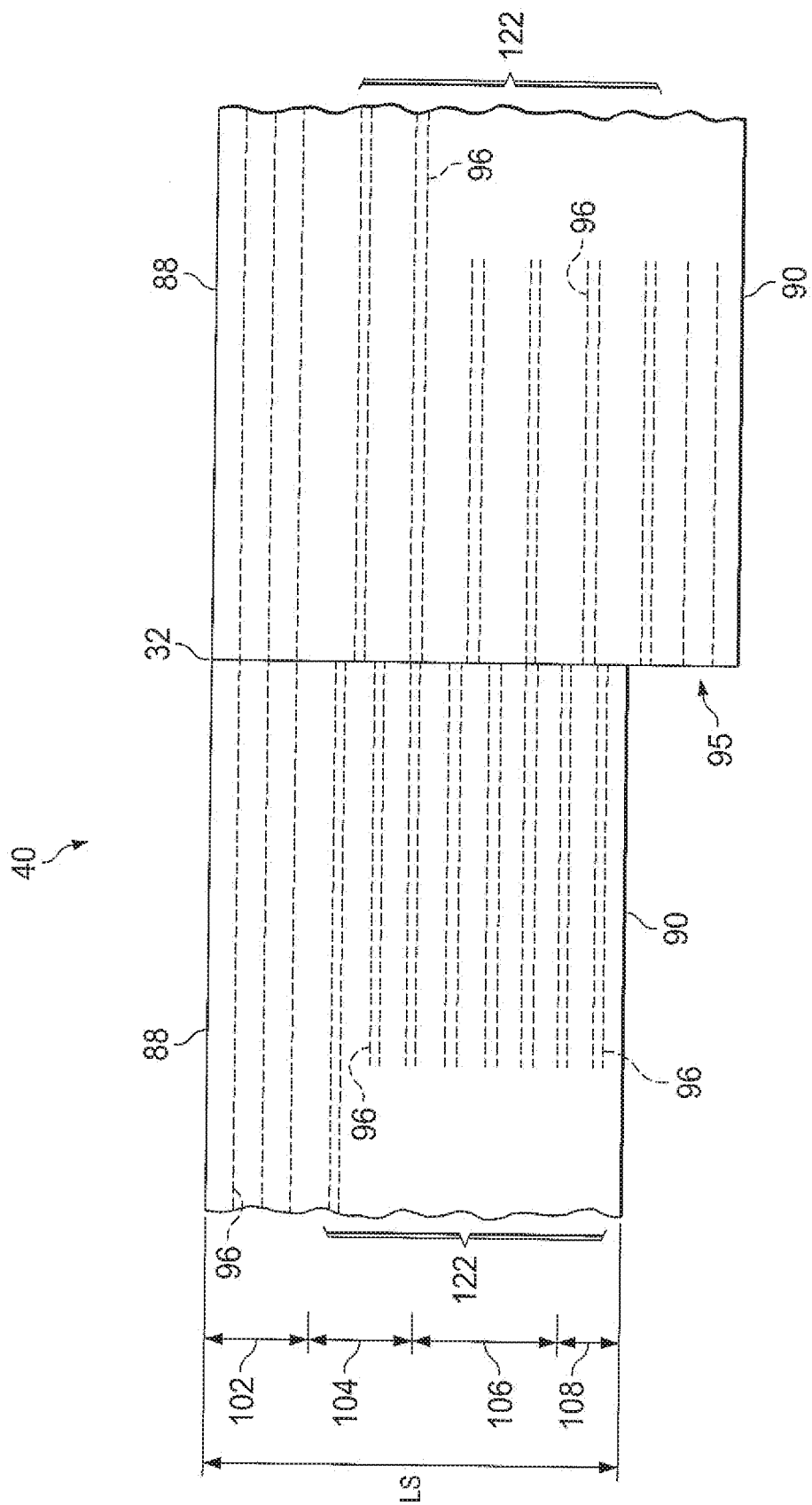

FIG. 4

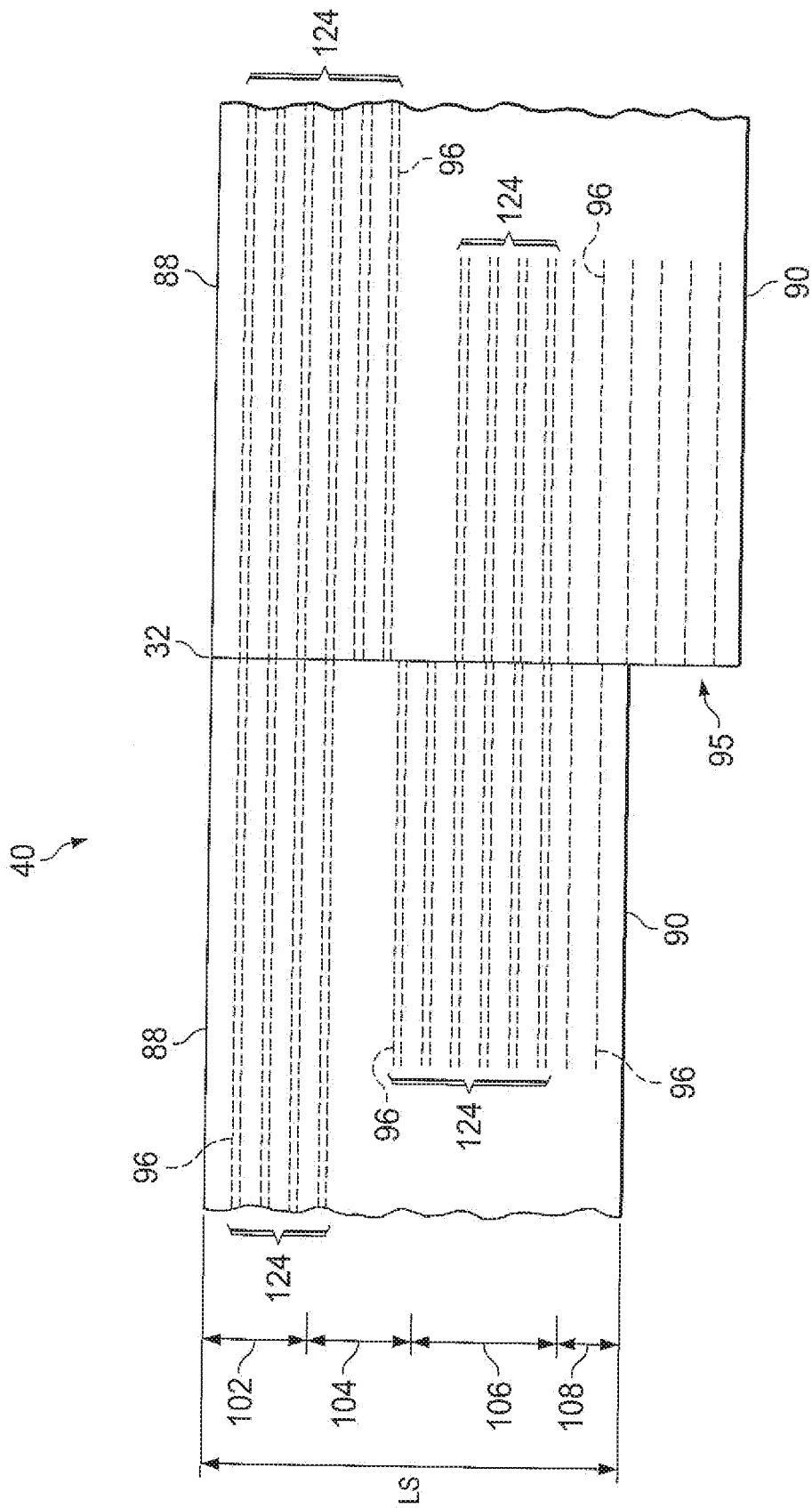

FIG. 5

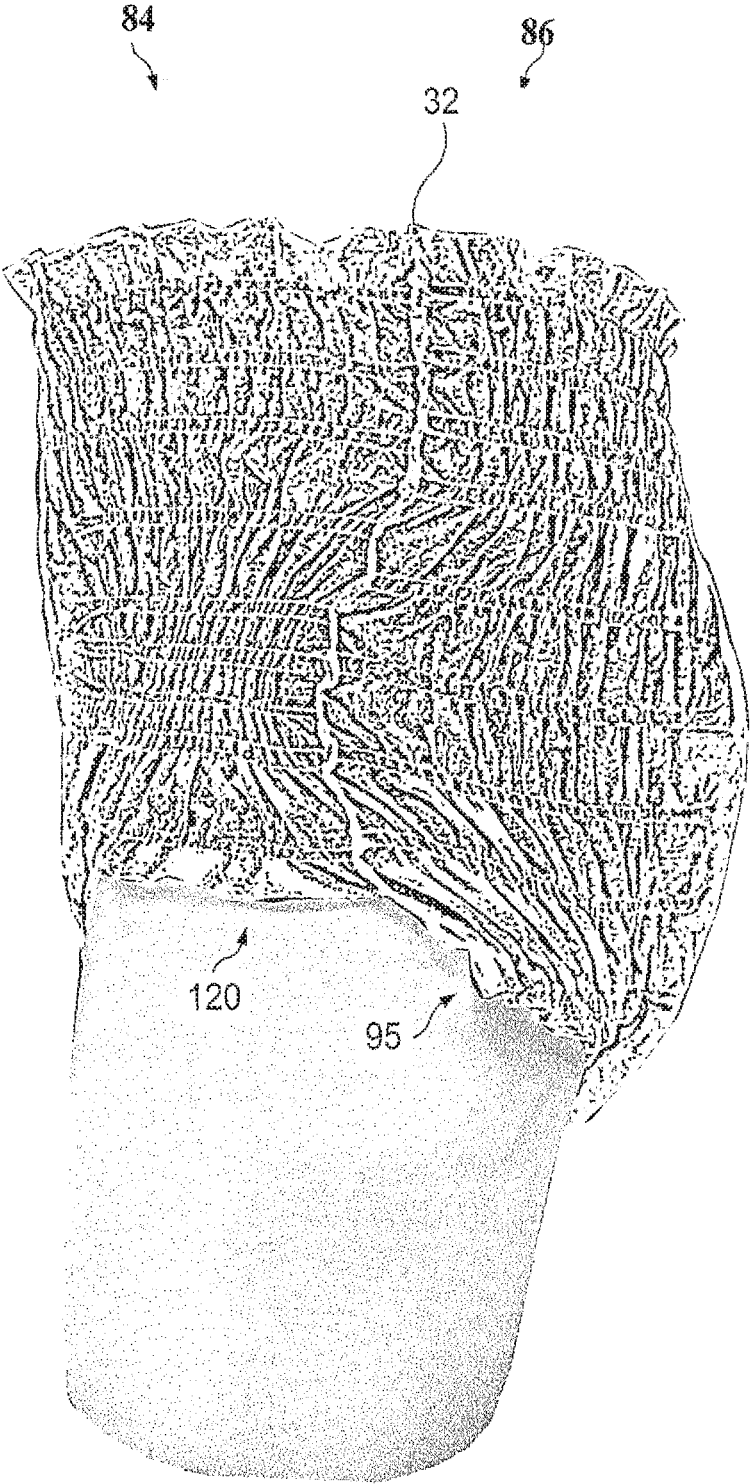

FIG. 6

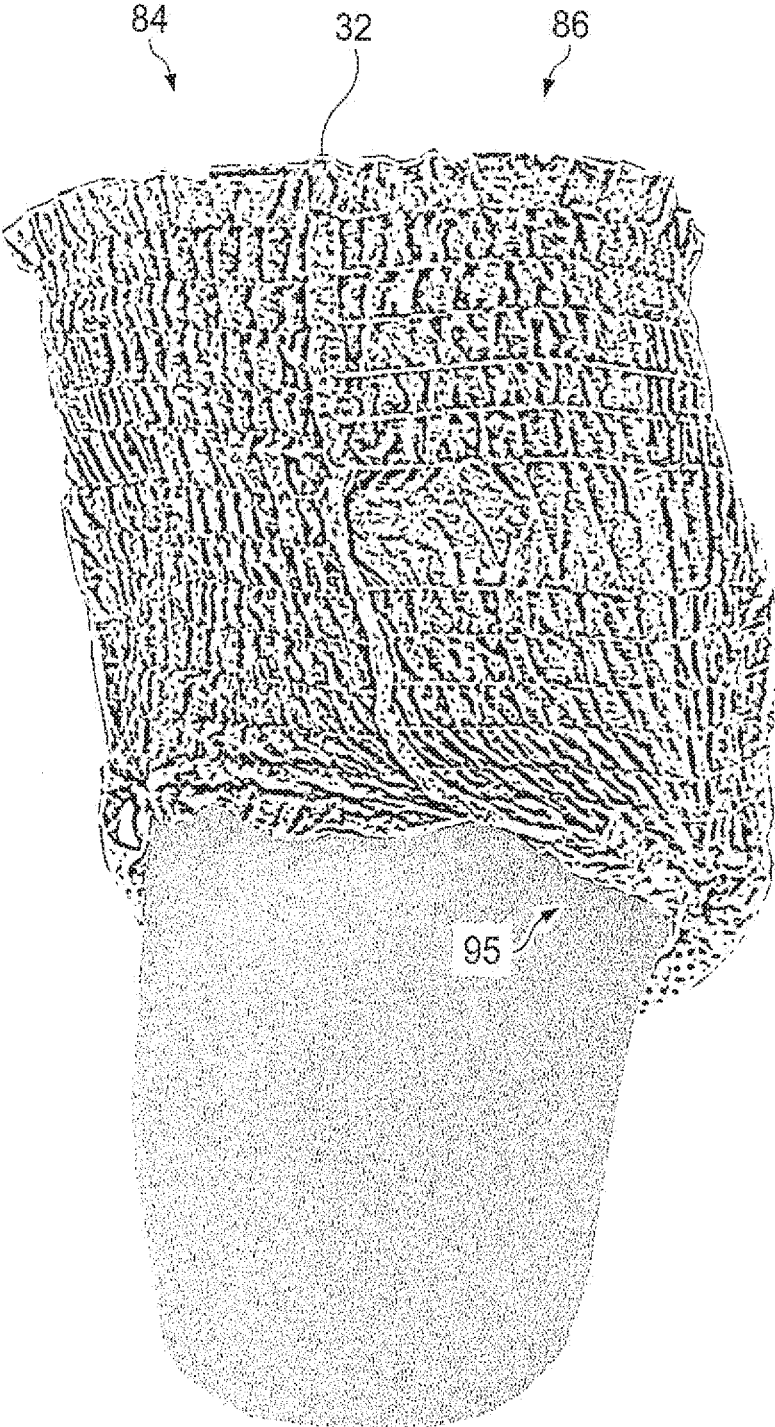

FIG. 7

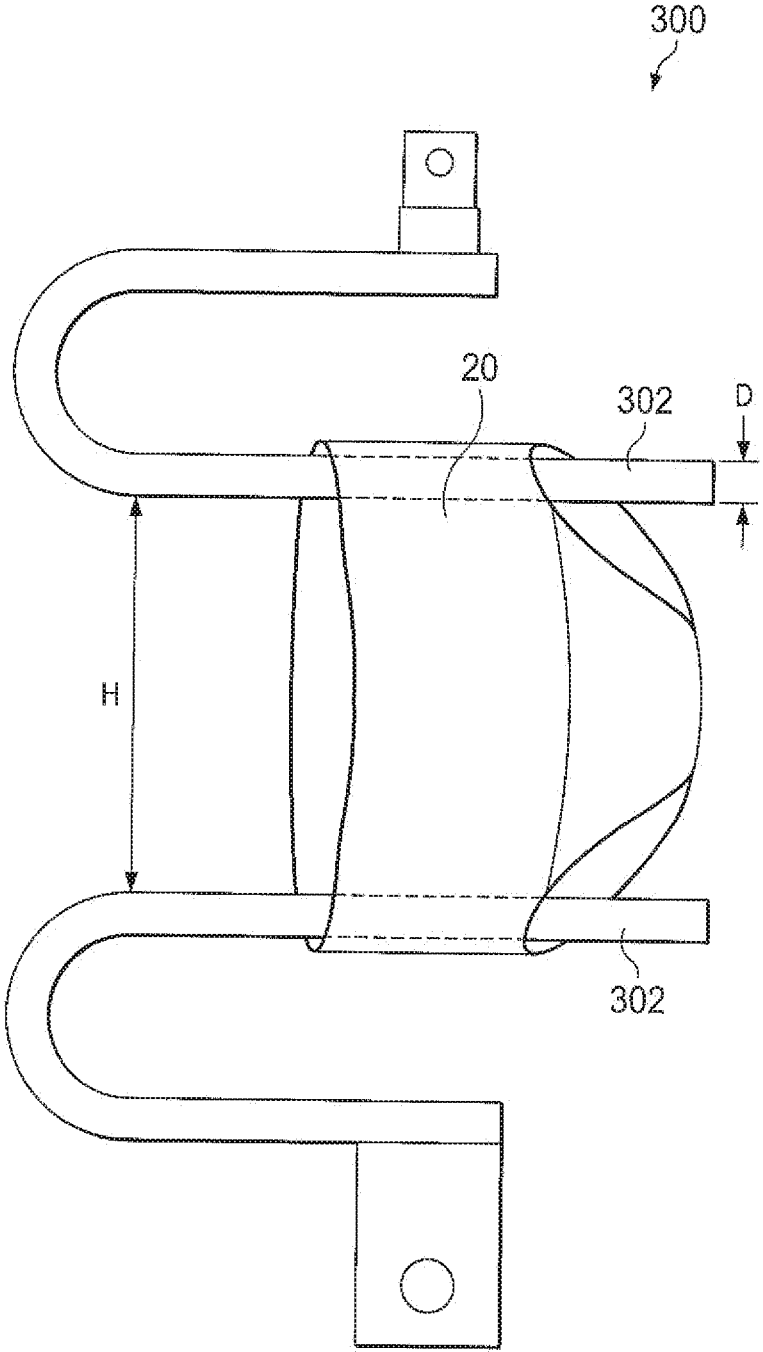

FIG. 8

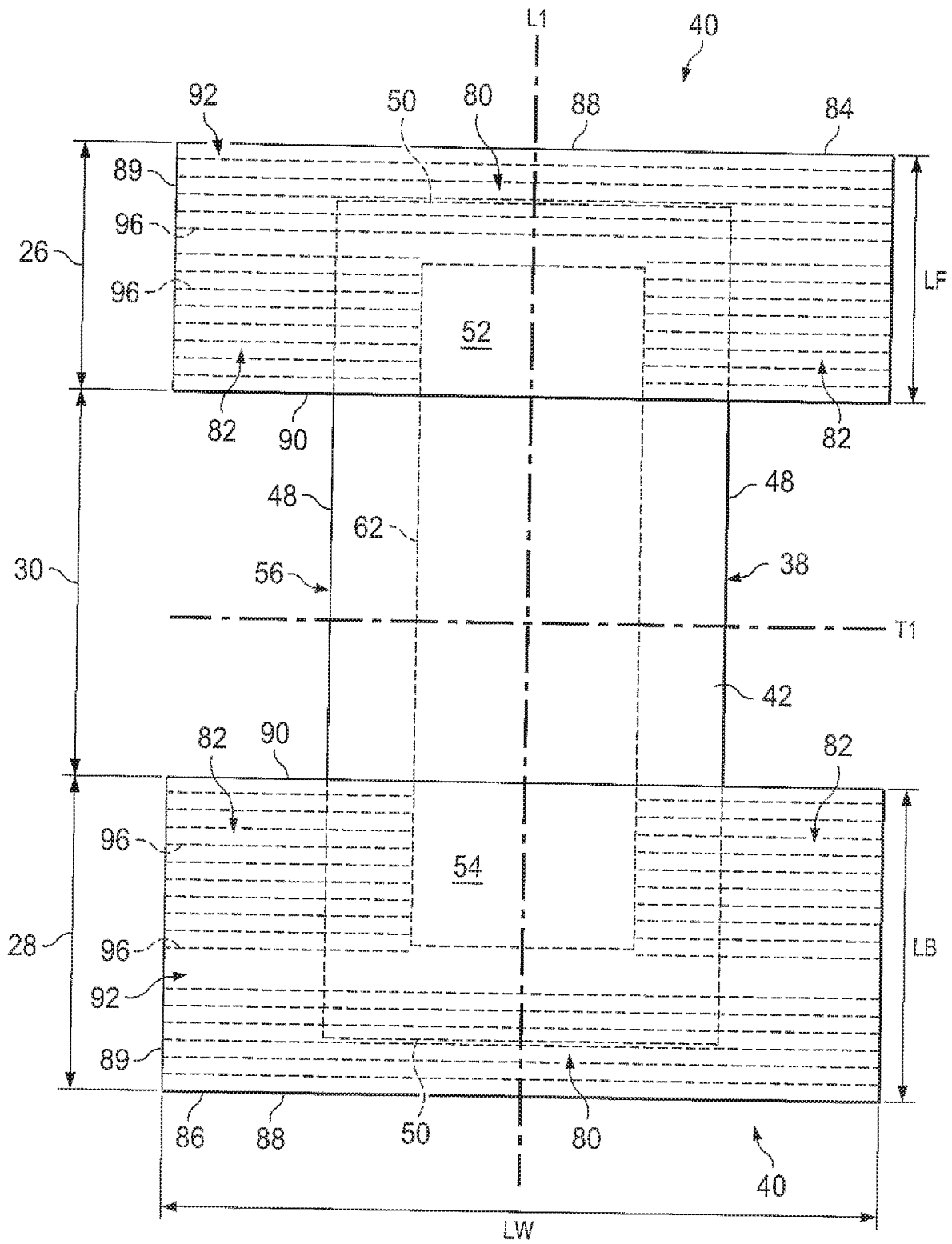

FIG. 9

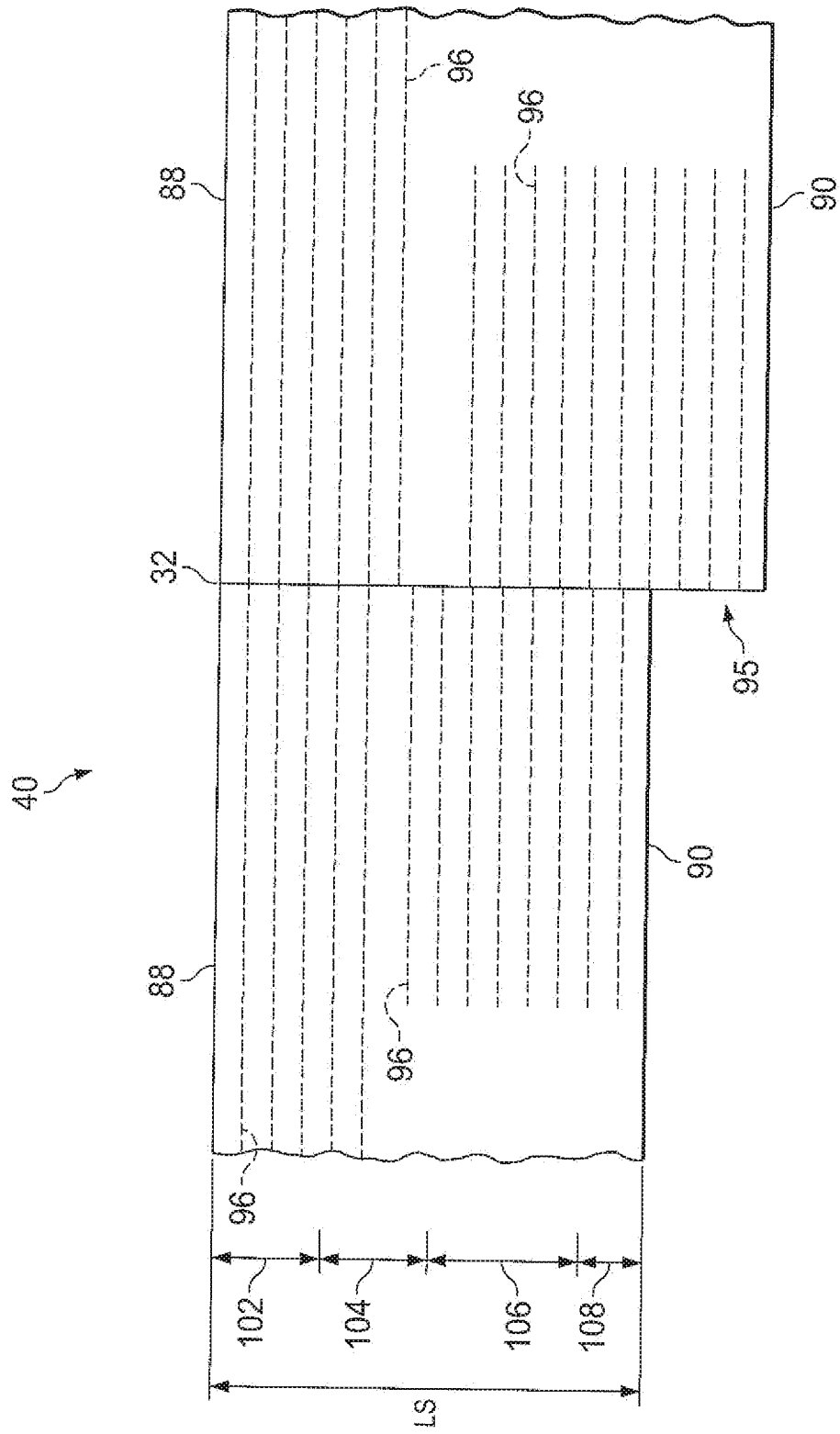

FIG. 10

WEARABLE ARTICLE HAVING ELASTIC BELT

CROSS REFERENCE TO RELATED APPLICATIONS

[0001] This application is a continuation of U.S. application Ser. No. 15/443,011, filed on Feb. 27, 2017, which is a continuation of Application No. PCT/CN2015/072189, filed on Feb. 4, 2015 and a continuation-in-part of Application No. PCT/CN2014/085251, filed on Aug. 27, 2014, the substances of which are herein incorporated by reference in their entirety.

FIELD OF THE INVENTION

[0002] The present disclosure relates to wearable articles having an elastic belt having arrays of elastic bodies.

BACKGROUND OF THE INVENTION

[0003] Infants and other incontinent individuals wear wearable articles such as diapers to receive and contain urine and other body exudates. Pull-on wearable articles, or pant-type wearable articles, are those which are donned by inserting the wearer's legs into the leg openings and sliding the article up into position about the lower torso. Pant-type absorbent articles have become popular for use on children who are able to walk and often who are toilet training, as well as for younger children who become more active in movement such that application of taped-type absorbent articles tends to be more difficult.

[0004] Many pant-type wearable articles use elastic elements secured in an elastically contractible condition in the waist and/or leg openings. Typically, in order to insure full elastic fit about the leg and the waist such as is provided with durable undergarments, the leg openings and waist opening are encircled at least in part with elasticized elements positioned along the periphery of the respective opening.

[0005] Pant-type wearable articles having a main body to cover the crotch region of the wearer and a separate elastic belt defining the waist opening and leg opening are known in the art, such as described in PCT Publication WO 2006/17718A. Such pant-type wearable articles may be referred to as belt-type pants. On the other hand, certain pant-type wearable articles are configured such that the outer cover of the wearable body completely covers the entirety of the garment-facing surface of the article. Such pant-type wearable articles may be referred to as uni-body pants. Belt-type pants, compared to uni-body pants, may be advantageous in having better breathability by having less layers of material in certain areas of the articles, and in that they may be manufactured economically. For belt-type pants, the elastic belt provides fit for not just the waist opening and low torso area, but also for the leg opening, in that the leg opening of belt-type pants are rendered elastic by the combination of elasticity provided by the main body and the elastic belt. Thus, for belt-type pants, sag protection and good fit for the entire article are mainly provided by the elastic belt. Providing a certain tensile stress for the elastic belt is essential for providing sag protection and good fit for the entire article. The elastic belt of belt-type pants are economically rendered elasticity by disposing a plurality of elastic strands running in the transverse direction of the article. The tensile force provided by the relatively thin elastic strands may lead

to red marking of the wearer's skin. Further, the tensile force provided by the elastic strands may lead to discomfort of the wearer.

[0006] Based on the foregoing, there is a need for a pant-type wearable article having balanced performance such as fit, comfort during wear, prevention of sagging, prevention of leakage, and prevention of red marking. There is further a need for providing such a wearable article in an economical manner.

SUMMARY OF THE INVENTION

[0007] The present disclosure is directed to a wearable article continuous in a longitudinal direction and a transverse direction, comprising a main body and a ring-like elastic belt comprising a front belt and a back belt. The center of the front belt may be joined to a front waist panel of the main body. The center of the back belt may be joined to a back waist panel of the main body. The front and back belt may each have a left side panel and a right side panel where the main body does not overlap. The transverse edges of the front belt and the back belt may be joined by a seam to form a waist opening and two leg openings. Each of the front belt and back belt may be formed by a plurality of elastic bodies running in the transverse direction sandwiched between an inner sheet and an outer sheet. Each of the front belt and back belt may have transversely continuous proximal and distal edges, the proximal edge being located closer than the distal edge relative to the longitudinal center of the article. At least some of the elastic bodies disposed on the front belt and the back belt may be arranged in an array meeting: a) one array is formed by 2-10 elastic bodies; b) each elastic body within one array is disposed in an inner-interval in the longitudinal direction between each elastic body of 2-4 mm; and c) one specific array disposed in an extra-interval in the longitudinal direction between at least one neighboring elastic bodies outside the specific array of greater than the inner-interval. The back belt may comprise at least 5 arrays.

BRIEF DESCRIPTION OF THE DRAWINGS

[0008] While the specification concludes with claims particularly pointing out and distinctly claiming the subject matter which is regarded as forming the present disclosure, it is believed that the invention will be better understood from the following description which is taken in conjunction with the accompanying drawings and which like designations are used to designate substantially identical elements, and in which:

[0009] FIG. 1 is a perspective view of one embodiment of a wearable article of the present disclosure.

[0010] FIG. 2 is a schematic plan view of one embodiment of a wearable article of the present disclosure with the seams unjoined and removed, and in a flat uncontracted condition showing the garment facing surface.

[0011] FIG. 3 is a schematic side plan view of one embodiment of a wearable article of the present disclosure in a flat uncontracted condition showing the garment facing surface.

[0012] FIG. 4 is a schematic side plan view of another embodiment of a wearable article of the present disclosure in a flat uncontracted condition showing the garment facing surface.

[0013] FIG. 5 is a schematic side plan view of another embodiment of a wearable article of the present disclosure in a flat uncontracted condition showing the garment facing surface.

[0014] FIG. 6 is a side view of one embodiment of a wearable article of the present disclosure worn on a mannequin.

[0015] FIG. 7 is a side view of a wearable article of the prior art worn on a mannequin.

[0016] FIG. 8 is a schematic view of an example of a hanger-type sample holding fixture according to the “Whole Article Force Measurement”.

[0017] FIG. 9 is a schematic plan view of one embodiment of a wearable article of the prior art with the seams unjoined and removed, and in a flat uncontracted condition showing the garment facing surface.

[0018] FIG. 10 is a schematic side plan view of one embodiment of a wearable article of the prior art in a flat uncontracted condition showing the garment facing surface.

DEFINITIONS

[0019] As used herein, the following terms shall have the meaning specified thereafter:

[0020] “Wearable article” refers to articles of wear which may be in the form of pants, taped diapers, incontinent briefs, feminine hygiene garments, and the like. The “wearable article” may be so configured to also absorb and contain various exudates such as urine, feces, and menses discharged from the body. The “wearable article” may serve as an outer cover adaptable to be joined with a separable disposable absorbent insert for providing absorbent and containment function, such as those disclosed in PCT publication WO 2011/087503A.

[0021] “Pant” refers to disposable absorbent articles having a pre-formed waist and leg openings. A pant may be donned by inserting a wearer’s legs into the leg openings and sliding the pant into position about the wearer’s lower torso. Pants are also commonly referred to as “closed diapers”, “prefastened diapers”, “pull-on diapers”, “training pants” and “diaper-pants.”

[0022] “Longitudinal” refers to a direction running substantially perpendicular from a waist edge to an opposing waist edge of the article and generally parallel to the maximum linear dimension of the article.

[0023] “Transverse” refers to a direction perpendicular to the longitudinal direction.

[0024] “Body-facing” and “garment-facing” refer respectively to the relative location of an element or a surface of an element or group of elements. “Body-facing” implies the element or surface is nearer to the wearer during wear than some other element or surface. “Garment-facing” implies the element or surface is more remote from the wearer during wear than some other element or surface (i.e., element or surface is proximate to the wearer’s garments that may be worn over the disposable absorbent article).

[0025] “Disposed” refers to an element being located in a particular place or position.

[0026] “Joined” refers to configurations whereby an element is directly secured to another element by affixing the element directly to the other element and to configurations whereby an element is indirectly secured to another element by affixing the element to intermediate member(s) which in turn are affixed to the other element.

[0027] “Extendibility” and “extensible” mean that the width or length of the component in a relaxed state can be extended or increased.

[0028] “Elasticated” and “elasticized” mean that a component comprises at least a portion made of elastic material.

[0029] “Elongatable material,” “extensible material,” or “stretchable material” are used interchangeably and refer to a material that, upon application of a biasing force, can stretch to an elongated length of at least about 110% of its relaxed, original length (i.e. can stretch to 10 percent more than its original length), without rupture or breakage, and upon release of the applied force, shows little recovery, less than about 20% of its elongation without complete rupture or breakage as measured by EDANA method 20.2-89. In the event such an elongatable material recovers at least 40% of its elongation upon release of the applied force, the elongatable material will be considered to be “elastic” or “elastomeric.” For example, an elastic material that has an initial length of 100 mm can extend at least to 150 mm, and upon removal of the force retracts to a length of at least 130 mm (i.e., exhibiting a 40% recovery). In the event the material recovers less than 40% of its elongation upon release of the applied force, the elongatable material will be considered to be “substantially non-elastic” or “substantially non-elastomeric”. For example, an elongatable material that has an initial length of 100 mm can extend at least to 150 mm, and upon removal of the force retracts to a length of at least 145 mm (i.e., exhibiting a 10% recovery).

DETAILED DESCRIPTION OF THE INVENTION

[0030] FIG. 1 is a perspective view of an embodiment of the wearable article 20 of the present disclosure and FIG. 2 is a schematic plan view of the same article with the seams unjoined and in its flat uncontracted condition showing the garment-facing surface. The wearable article 20 has a longitudinal centerline L1 which also serves as the longitudinal axis, and a transverse centerline T1 which also serves as the transverse axis. The wearable article 20 has a skin-facing surface, a garment-facing surface, a front region 26, a back region 28, a crotch region 30, and seams 32 which join the front region 26 and the back region 28 to form two leg openings and a waist opening. The wearable article 20 comprises a main body 38 to cover the crotch region of the wearer, a front belt 84 and a back belt 86 (hereinafter may be referred to as “front and back belt”), the front and back belts 84, 86 forming a ring-like elastic belt 40 (hereinafter may be referred to as “waist belt”) extending transversely defining the waist opening. The front and back belts 84, 86 and the main body 38 jointly define the leg openings.

[0031] The main body 38 may contain an absorbent core 62 for absorbing and containing body exudates disposed on the main body 38. In the embodiment shown in FIG. 2, the main body 38 has a generally rectangular shape, left and right longitudinally extending side edges 48 (hereinafter may be referred to as “side edge”) and front and back transversely extending end edges 50 (hereinafter may be referred to as “end edge”). The main body 38 also has a front waist panel 52 positioned in the front region 26 of the wearable article 20, a back waist panel 54 positioned in the back region 28, and a crotch panel 56 between the front and back waist panels 52, 54 in the crotch region 30. The center of the front belt 84 is joined to a front waist panel 52 of the main body 38, the center of the back belt 86 is joined to a

back waist panel **54** of the main body **38**, the front and back belt **84, 86** each having a left side panel and a right side panel **82** where the main body **38** does not overlap.

[0032] Referring to FIGS. 1 and 2, the ring-like belt **40** formed by the front belt **84** and back belt **86** acts to dynamically create fitment forces and to distribute the forces dynamically generated during wear. Herein, the term “proximal” is used to indicate the position of a “proximal” portion being closer relative to the longitudinal center of the article, also closer relative to the crotch panel **56** of the main body **38** than the position of a “distal” portion. Therefore, the proximal edge **90** is located closer than the distal edge **88** relative to the crotch panel **56** of the main body **38**. The front and back belts **84, 86** may be joined with each other only at the side edges **89** at the seams **32** to form a wearable article having a waist opening and two leg openings. Each leg opening may be provided with elasticity around the perimeter of the leg opening by the combination of elasticity from the front belt **84**, the back belt **86**, and any from the main body **38**. The front leg opening region **120** is disposed adjacent the leg opening along the proximal edge **90** of the left and right side panels **82** of the front belt **84**.

[0033] The front and back belts **84, 86** are discontinuous with one another in the crotch region **30**. In such embodiment, there is no material that covers the entirety of either the wearer-facing surface or garment-facing surface of the article. The front central panel **80** may partly overlap with the front waist panel **52** of the main body **38**. The back central panel **80** may partly overlap with the back waist panel **54** of the main body **38**. However, the central panels **80** may not extend into the crotch panel **56** of the main body **38** and not be disposed in the crotch panel **56**. In the embodiment shown in FIG. 2, the central panels **80** partly overlap with and are joined to the front waist panel **52** and the back waist panel **54**, respectively.

[0034] Referring to FIG. 2, the front belt **84** and back belt **86** may each comprise an inner sheet **94**, an outer sheet **92**, (hereinafter also collectively “belt sheets”) and configured to impart elasticity per each zone according to the relationship described below. (The inner sheet **94** is not shown.) Each of the front and back belts **84, 86** may be made as a laminate having a plurality of belt elastic bodies **96** sandwiched between the inner and outer sheets **94, 92**. In one embodiment, the belt elastic bodies **96** extend in the transverse direction to provide a ring-like elastic belt when the front belt **84** and the back belt **86** are joined. In one embodiment, at least some of the elastic bodies **96** extend in the transverse direction parallel to each other. In one embodiment, all of the elastic bodies **96** extend in the transverse direction substantially parallel to each other. Such an article may be economically made.

[0035] In one embodiment, the effective transverse width LW of the back belt **86** in the uncontracted condition may be the same as the transverse width of the front belt **84** of the same condition. By “effective transverse width”, what is meant is the width available for forming the wearer-facing surface of the article. In one embodiment, each of the proximal edges **90** and the distal edges **88** of the front belt **84** and the back belt **86** may be substantially parallel, as in FIG. 2.

[0036] In one embodiment, the longitudinal length LB of the back belt **86** between the back distal edge **88** and the back proximal edge **90** along its entire width LW of the back belt **86** may be approximately the same as the longitudinal

length LF of the front belt **84** between the front distal edge **88** and the front proximal edge **90**. In such embodiment, the seams **32** close the front and back belt **84, 86** side edges **89** of the same length for forming the article. Such an article may be economically made.

[0037] In one embodiment, the back belt **86** may have a greater longitudinal length LB between the back distal edge **88** and the back proximal edge **90** along its entire width LW of the back belt **86** in the transverse direction than the longitudinal length LF of the front belt **84** between the front distal edge **88** and the front proximal edge **90** (FIGS. 1-5). In such embodiment, when the wearable article is assembled to form the waist opening and the leg openings, the wearable article **20** is folded along the transverse centerline T1 such that the front distal edge **88** is aligned with the back distal edge **88**. The front side edge **89** is also aligned with a portion of the back side edge **89**. Then the front belt **84** and the back belt **86** are joined at the front and back side edges **89** at the seams **32**. The front and back proximal edges **90**, however, may not be aligned to one another. The back proximal edge **90** may be disposed longitudinally closer than the front proximal edge **90** relative to the transverse center line T1 such that the proximal portion of the back side panel **82** extends toward the crotch panel **56** of the main body **38** beyond the front proximal edge **90**. The side edge of the proximal portion of the back side panel **82** may not be joined to anywhere and free from attachment. Thus, the proximal portion of the back side panel **82** provides a buttock cover **95** as in FIG. 1.

[0038] Whether or not the longitudinal length LB of the back belt **86** and the longitudinal length LF of the front belt **84** are the same, the entirety of the longitudinal length LF of the belt side edge **89** of the front belt **84** may be seamed with the belt side edge **89** of the back belt **86** to define a seam length LS, as in FIG. 3. When the front belt **84** has straight distal edges **88** and proximal edges **90** that are substantially parallel of each other, then the longitudinal length LF of the front belt **84** is equal to the seam length LS.

[0039] In one embodiment, the outer sheet **92** of the front or back belt **84, 86** towards the distal edge **88** may be longer than the size of the inner sheet **94** in the longitudinal direction, and an end flap of the outer sheet **92** may be folded over the distal end of the inner sheet **94** at the waist opening. The front and back belts **84, 86** may be provided in low caliper non-woven material for sake of breathability and softness of the belt **40**.

[0040] The tensile stress (N/m) of the front and back elastic belts **84, 86**, respectively, may be profiled in order to provide the benefits of the present disclosure. The tensile stress may be measured, for example, by the Belt Zone Tensile Stress Measurement described herein below. When the elasticity of the front and back elastic belts **84, 86** are provided by a plurality of elastic bodies **96** running in the transverse direction, the tensile stress may be adjusted by one or more of the following methods; 1) elongation rate of the elastic body **96**; 2) density (dtex) of the elastic body **96**; 3) longitudinal interval of multiple elastic bodies **96**; and 4) effective length of elasticity of the elastic body **96** in the transverse direction. By elongation, “0% elongation” is meant the original length of the elastic body. When a portion of an elastic body is removed of its elasticity, the remainder of the intact elastic body capable of imparting elasticity is defined as the “effective length of elasticity of an elastic body”. The elastic bodies **96** disposed on the front and/or

back belt **84**, **86** may be treated such that certain of the area overlapping the front and/or back waist panels **52**, **54** of the main body **38** are removed of elasticity. Removal of elasticity from at least a portion of the area overlapping the front and/or back waist panel **52**, **54** of at least one elastic body may be advantageous when the main body **38** comprises an absorbent core **62**, in that elasticity in the front and/or back area may cause bunching of the absorbent core **62** and interfere with close fit of the main body **38** to the wearer. In one embodiment, at least a portion of, or at least 10% of, or at least 20% of, or at least 30% of, the elasticity of; at least one of, or at least half of, or at least two thirds of, or all of, the elastic bodies are removed in the region overlapping with the front and back waist panels **52**, **54** or the absorbent core **62** of the main body **38**.

[0041] Referring to FIG. 3, the elastic bodies **96** of the belt **40** of the present disclosure may be arranged in arrays. The arrays of the present disclosure, whether basic array **122** or concentrated array **124**, have at least 2 elastic bodies **96** disposed in close proximity to each other in the longitudinal direction. Specifically, a plurality of elastic bodies **96** are disposed at an interval, herein defined as an inner-interval **132**, of 2-4 mm. Any two or more elastic bodies **96** disposed in an inner-interval **132** of 2-4 mm are referred to herein as an array. Without being bound by theory, by disposing the elastic bodies **96** in such close proximity to each other, the array exhibits a behavior as if it were one elastic body with a certain width, and provides various benefits. For example, the array provides more or less the combined tensile force of the elastic bodies **96** in the array, such that each elastic body **96** may be disposed at a much lower tensile force. Further, the gathers created in the inner-interval **132** of the array are so fine that the area of the inner sheet **94** facing the wearer is significantly increased. Such increased area of material in the inner-interval **132**, combined with the elastic bodies **96** of the array, apply a tensile force to the wearer over a distributed width, compared to the width of a single elastic body. Namely, the array exhibits a behavior as if it were one elastic body. As such, the array may provide a good fit to the wearer by using relatively low density elastic bodies which are economically supplied. The reduction of tensile stress in a concentrated area compared to that of a single elastic body, may also reduce red marking on the skin of the wearer, and provide the wearer with a more comfortable and soft fit. Further, an array may provide the appearance of an elastic body of a certain width, similar to elastic bodies disposed on a durable undergarment. Thus, disposal of an array may connote an undergarment look, or high quality.

[0042] Herein, the basic array **122** comprises 2-10 elastic bodies, or 2-5 elastic bodies, or 2-3 elastic bodies. Herein, the concentrated array **124** comprises 2-4 elastic bodies, or 2-3 elastic bodies. The basic array **122** may be disposed in a relatively large extra-interval **134** in the longitudinal direction between at least one neighboring elastic body outside the array, of 8-22 mm. The concentrated array **124** may be disposed in a relatively small extra-interval **134** in the longitudinal direction between at least one neighboring elastic body outside the array of less than 8 mm, or from 4 to less than 8 mm; wherein the extra-interval **134** is greater than the inner-interval **132**.

[0043] In summary, an array may be defined as meeting a), b), and c) as follows:

- a) one array is formed by 2-10 elastic bodies;
- b) each elastic body within one array is disposed in an inner-interval **132** in the longitudinal direction between each elastic body of 2-4 mm;
- c) one specific array disposed in an extra-interval **134** in the longitudinal direction between at least one neighboring elastic bodies outside the specific array of greater than the inner-interval **132**.

[0044] In summary, a basic array **122** may be defined as meeting a), b), and c) as follows:

- a) one basic array **122** is formed by 2-10 elastic bodies;
- b) each elastic body within one basic array **122** is disposed in an inner-interval **132** in the longitudinal direction between each elastic body of 2-4 mm;
- c) one specific basic array **122** disposed in an extra-interval **134** in the longitudinal direction between at least one neighboring elastic body outside the specific basic array **122** of 8-22 mm.

[0045] In summary, a concentrated array **124** may be defined as meeting a), b), and c) as follows:

- a) one concentrated array **124** is formed by 2-4 elastic bodies;
- b) each elastic body within one concentrated array **124** is disposed in an inner-interval **132** in the longitudinal direction between each elastic body of 2-4 mm;
- c) one specific concentrated array **124** disposed in an extra-interval **134** in the longitudinal direction between at least one neighboring elastic body outside the specific concentrated array **124** of greater than the inner-interval **132** of the specific concentrated array **124** and less than 8 mm.

[0046] The front belt **84** may comprise at least 5 arrays. The front belt **84** may comprise at least 1, or at least 2, or at least 3, or at least 4 basic arrays **122**. The elastic bodies disposed on the front belt **84** may all be arranged in arrays. The front belt **84** may comprise basic arrays **122** and concentrated arrays **124**. The elastic bodies disposed on the front belt **84** may all be arranged in either basic arrays **122** or concentrated arrays **124**.

[0047] The back belt **86** may comprise at least 5 arrays. The back belt **86** may comprise at least 1, or at least 2, or at least 3, or at least 4 basic arrays **122**. The elastic bodies disposed on the back belt **86** may all be arranged in arrays. The back belt **86** may comprise basic arrays **122** and concentrated arrays **124**. The elastic bodies disposed on the back belt **86** may all be arranged in basic arrays **122**.

[0048] Referring again to FIG. 3, arrays may be disposed on both the front belt **84** and the back belt **86**. The arrays from the front and back belt **84**, **86** may be disposed in a matched arrangement **136**. By matched arrangement **136**, what is meant is that at least one elastic body comprised in an array at the belt side edge **89** of the front belt **84** and at least one elastic body comprised in an array at the belt side edge **89** of the back belt **86** are located in substantially the same position at both seams **32**. By substantially same position, what is meant is a position within reasonable deviation from the designed arrangement occurred in high speed production of the article, for example within 4 mm, or within 2 mm. In one embodiment, all of the elastic bodies comprised in an array at the belt side edge **89** of the front belt **84** and all of the elastic bodies comprised in an array at the belt side edge **89** of the back belt **86** may be located in substantially the same position at both seams **32**. In embodi-

ments where the distal edges **88** of the front and back belts **84, 86** are substantially parallel and matched, and also all of the elastic bodies **96** extend in the transverse direction substantially parallel to each other such as in FIGS. 2-5, a matched arrangement may alternatively be identified by comparing the position of the array located from the distal edge **88** of the belt. When the positions of the arrays from the distal edge **88** in the front and back belt **84, 86** match, then this is considered a matched arrangement.

[0049] Matched arrangements **136** may be formed by either basic arrays **122** or concentrated arrays **124**. Matched arrangements **136** of arrays may be useful for providing clearly defined gathers in the extra-interval **134**, such as in the vicinity of the waist opening or the leg opening. The area indicated as **136** in FIG. 3 is considered to include 2 matched arrangements **136**.

[0050] Still referring to FIG. 3, when there are at least 3 basic arrays disposed on the article, the arrays may be disposed in a certain location in the longitudinal direction such that the arrays are in an alternate arrangement **138**. By alternate arrangement **138**, what is meant is an arrangement of either e) or f) as follows:

[0051] e) the belt side edge **89** of one specific basic array comprised in the front belt **84** is located in the extra-interval **134** of two basic arrays of the back belt **86** at the belt side edge **89**;

[0052] f) the belt side edge **89** of one specific basic array comprised in the back belt **86** is located in the extra-interval **134** of two basic arrays of the front belt **84** at the belt side edge **89**.

[0053] There may be more than one, for example 2 or 3, specific basic arrays comprised in either the front or back belt **84, 86** at the belt side edge **89** being located in the extra-interval **134** of two arrays comprised in the other side belt at the belt side edge **89**.

[0054] Namely, at both seams **32**, an alternate arrangement is identified when at least one basic array **122** at the belt side edge **89** of one of the front or back belt **84, 86** is located in the extra-interval **134** of 2 basic arrays **122** at the belt side edge **89** of the other front or back belt **84, 86**. Alternate arrangements **138** of basic arrays **122** may be useful for providing a soft fit around the side seam **32** by distributing the forces provided by the basic arrays **122** disposed on the front belt and the back belt **84, 86**. There are two areas indicated as **138** in FIG. 3. The two areas indicated as **138** in FIG. 3 are considered to include a total of 5 alternate arrangements **138**. The article of the present disclosure may have at least 2, or at least 3 alternate arrangements **138**.

[0055] As described above, the basic array **122** or concentrated array **124** of the present disclosure may provide more or less the combined tensile force of the elastic bodies **96** in the array, such that each elastic body **96** may be disposed at a relatively lower tensile force. Accordingly, the elastic bodies **96** for forming a basic array **122** may have a density of no more than 940 dtex, and disposed at an elongation of from 100% to 350%, or from 150% to 300%. By elongation, "0% elongation" is meant the original length of the elastic body. The elastic bodies **96** for forming a concentrated array **124** may have a density of no more than 1100 dtex, or no more than 940 dtex, and disposed at an elongation of from 150% to 300%.

[0056] In one embodiment, the total number of elastic bodies **96** disposed on a single article may be limited for providing the article in an economical manner. The belt of

the present disclosure may be disposed of a total of no more than 60, or no more than 54, or no more than 46 elastic bodies. The article of the present disclosure may have an entire longitudinal length of the article of from 350 mm to 600 mm, an effective transverse belt width (LW) of from 315 mm to 500 mm, a back belt longitudinal length (LB) of from 100 mm to 180 mm, a front belt longitudinal length (LF) of from 80 mm to 160 mm, a main body longitudinal length of from 310 mm to 560 mm, and a main body transverse width of from 150 mm to 210 mm. The article of the present disclosure may have a distance between the distal edge of the front belt to the longitudinal edge of the main body of from 0 mm to 70 mm, and a distance between the distal edge of the back belt to the longitudinal edge of the main body of from 0 mm to 90 mm, and such distances on the front and back belt may be the same or different. The longitudinal length of the main body may be from 70% to 100% of the entire longitudinal length of the article. When the main body comprises an absorbent core **62**, the core may have a longitudinal length of from 270 mm to 500 mm, a maximum transverse width of the core of from 90 mm to 125 mm, and a distance between the longitudinal edge of the core to the longitudinal edge of the main body of from 10 mm to 40 mm. The longitudinal length of the core may be from 60% to 95% of the entire longitudinal length of the article, or from 66% to 97% of the main body. The article of the present disclosure may have a Waist Circumference Force provided by the elastic bodies **96** disposed on the waist belt **40** of no more than 10N, or no more than 8N, according to the Whole Article Force Measurement as described herein below. The Whole Article Force Measurement is for quantifying the force provided by the article **20** when stretched along the waist circumference, simulating initial stretch experience of the article **20** in the transverse direction when the user inserts hands in the article and expands the article. Namely, more or less the total tensile force provided by the elastic bodies **96** disposed in the transverse direction is measured. While there may be other elastic bodies disposed on the article, for example along the longitudinal side edges of the main body, the impact of such other elastic bodies are known to be small, when the user stretches the article in the transverse direction. The Whole Article Force Measurement is obtained by extending, or loading, the article in the transverse direction until a force of 19.6N is attained, wherein the force at the point where the belt **40** article reaches 70% of the maximum stretch is obtained. The force expected to be perceived by the user for expanding the article may be controlled, such that the user may experience a satisfying expansion of the belt **40** without excess effort.

[0057] Elastic bodies arranged in basic arrays **122**, concentrated arrays **124**, or otherwise, may be disposed in combination in different zones of the elastic belt for creating areas of higher and lower tensile stress. Referring to FIGS. 3-5, the front and back belts **84, 86** are each divided into 4 zones extending in the transverse direction and defined of its position from the distal edge **88** to the proximal edge **90** relative to the percentage of the seam length LS. The entirety of the length of the belt side edge **89** of the front belt **84** is seamed with a certain length of the belt side edge **89** of the back belt **86** to define a seam length LS. When seam length LS is considered 0% at the distal edge **88** and 100% at the proximal edge **90** of the front belt **84**, the zones are defined as such: 0-25% is the waist zone **102**, 25-50% is the distal tummy zone **104**, 50-85% is the proximal tummy zone **106**,

and 85-100% is the leg zone 108. When there is an elastic body disposed at 25% from the distal edge 88, such elastic body is considered to be included in the waist zone 102. When there is an elastic body disposed at 50% from the distal edge 88, or 85% from the distal edge 88, such elastic body is considered to be included in the proximal tummy zone 106. For embodiments where the back belt 86 has a greater longitudinal length LB than the longitudinal length LF of the front belt 84, the remaining length of “LB minus LS” of the back belt 86 is not counted in the 4 zones described above.

[0058] Referring to FIG. 3, at least one alternate arrangement 138 may be located in at least one of the distal tummy zone 104, the proximal tummy zone 106, and the leg zone 108. At least one matched arrangement 136 may be located in at least one of the waist zone 102 and the leg zone 108. The waist zone 102 may comprise at least one matched arrangement 136, the distal tummy zone 104 may comprise at least one alternate arrangement 138, the proximal tummy zone 106 may comprise at least one alternate arrangement 138, and the leg zone 108 may comprise at least one matched arrangement 136. All of the elastic bodies 96 disposed on the waist zone 102 may be in a matched arrangement 136, and all of the elastic bodies 96 disposed on the distal tummy zone 104 may be in an alternate arrangement 138.

[0059] Referring to FIGS. 3-5, the tensile stress of the front proximal tummy zone 106 may be provided higher than the tensile stress of any other zone. This may be achieved by having concentrated arrays 124 disposed on the front proximal tummy zone 106 such as in FIG. 3. This may also be achieved by disposing basic arrays 122 of different extra-intervals 134 such as in FIG. 4. This may also be achieved by disposing concentrated arrays 124 in both the front and back belts 84, 86 such as in FIG. 5. The tensile stress of the front leg zone 108 may be no more than 50% of the tensile stress of the front proximal tummy zone 106, and the tensile stress of the back leg zone 108 may be no more than 100% of the tensile stress of the back proximal tummy zone 106. The tensile stress of the front distal tummy zone 104 may be lower than the tensile stress of the back distal tummy zone 104.

[0060] The profiling and arrangement of elastic bodies 96 of FIGS. 3-5 may provide the article of the present disclosure to take an S-curve side seam 32 observed by the side when worn by the wearer, as shown as in FIG. 6. Such behavior of the waist belt 40 of the present disclosure is in contrast with many belt-type wearable articles available in the market as shown in FIG. 7, wherein the side seam 32 takes a relatively straight line, or a line slightly slanted toward the back. Without being bound by theory, the aforementioned profiling of the elastic bodies 96 per zone is believed to provide the article of the present disclosure with a shaped waist belt 40 that conforms well to a human body, particularly to a lower torso of a child of less than 36 months of age, and therefore provides good fit and comfort to the wearer, without compromise of sagging prevention or leakage prevention. Namely, the front proximal zone is subject to high tensile stress such that the article may be anchored against the wearer’s trochanter, while facilitating leg movement, and further leaving more area for the back proximal zone to accommodate the wearer’s buttock. Further, by providing a higher tensile stress to the back distal tummy zone 104 compared to the front distal tummy zone 104, the wearer’s front waist area is accommodated.

Whole Article Force Measurement

[0061] Force is measured using an Electronic Tensile Tester with a computer interface such as the MTS Criterion C42 running TestWorks 4 Software (available from MTS SYSTEMS (CHINA) CO., LTD) or equivalent instrument. A load cell is selected so that force results for the samples tested will be between 10 and 90% of capacity of the load cell used. The instrument is calibrated according to the manufacturer’s instructions. All testing is performed in a room maintained at $23\pm 2^\circ$ C. and $50\pm 5\%$ relative humidity.

[0062] The tensile tester is fitted with hanger-type sample holding fixtures 300 as shown in FIG. 8. Each fixture comprises a rigid linear rubber-coated horizontal bar section 302 to prevent sample slippage during testing. The outer bar diameter (including the rubber coating) of the horizontal bar sections is 10.0 mm. The central axes of the horizontal bar sections 302 are configured to remain parallel and in the same vertical plane throughout the test procedure. The gauge circumference is determined by the following equation:

$$\text{Gauge Circumference} = 2 \times (H + D + \pi D / 2)$$

where H is the vertical gap between the horizontal bar sections 302, and D is the outer diameter of the bar.

[0063] The instrument is set up to go through the following steps:

Crosshead Speed	254.0 mm/min
Final Load Point	19.61N
Hold Time	0
Number of Cycles	1
Data Acquisition Rate	50 Hz

[0064] A sample article 20 is inserted onto the upper horizontal bar section 302 so that the bar passes through the waist opening and one leg opening of the article. The crosshead is raised until the specimen hangs above the lower bar and does not touch lower bar 302. The load cell is tared and the crosshead is lowered to enable the lower bar 302 to be inserted through the waist opening and other leg opening without stretching the article. The article is adjusted so that the longitudinal centerline L1 of the article is in a horizontal plane halfway between the upper and lower bars 302. The center of the side portion in contact with the bar 302 is situated on the same vertical axis as the instrument load cell. The crosshead is raised slowly while the article is held in place by hand as necessary until the force is between 0.05 and 0.1N, while taking care not to add any unnecessary force. The gauge circumference at this point is the Initial Gauge Circumference. The test is initiated and the crosshead moves up at 254 mm/min until a force of 19.6N is attained, then the crosshead immediately returns to the initial gauge circumference at the same speed. The maximum circumference at 19.6N and the force at 70% stretch circumference during the extension segment of the test are recorded.

$$\text{Circumference (mm)} = 2 \times (H + D + \pi D / 2)$$

[0065] The maximum circumference at 19.6N is defined as the Full Stretch Circumference (mm). The 70% stretch circumference is defined as the full stretch circumference $\times 0.7$. The Waist Circumference Force is defined as the force at 70% stretch circumference during the load (extension) segment of the test.

[0066] Five samples are analyzed and their average Initial Gauge Circumference, average Full Stretch Circumference

and average Waist Circumference Force are calculated and reported to the nearest 1 mm, 1 mm and 0.01 N, respectively.

Belt Zone Tensile Stress Measurement

[0067] The tensile stress (N/m) is calculated by tensile force (N) divided by the specimen width (m). Force may be measured using an Electronic Tensile Tester with a computer interface such as the MTS Criterion C42 running TestWorks 4 Software (available from MTS SYSTEMS (CHINA) CO., LTD) or equivalent instrument. A load cell is chosen so that force results for the samples tested will be between 10 and 90% of capacity of the load cell. The instrument is calibrated according to the manufacturer’s instructions. All testing is performed in a room maintained at 23±2° C. and 50±5% relative humidity. The instrument is equipped with single line contact grips at least as wide as the test specimen.

[0068] To obtain test specimens, the sample article is cut open along the side seams **32**, and the front and rear elastic belt sections **40** are removed from the main body **38** by separating the bonding between the waist belt and main body. Cold Spray may be used, paying attention not to make wrinkles in the belt sections. Care is taken not to spray on any belt elastic body **96**. The obtained elastic belts **40** are severed into zones **102, 104, 106, 108** according to the present disclosure with care not to cut any elastic body **96**. Samples are pre-conditioned at 23° C.±2° C. and 50%±5% relative humidity for two hours prior to testing.

[0069] The instrument is set up to go through the following steps. Initial Gauge Length is calculated from the Initial Gauge Circumference which is determined during the Whole Article Force Test using separate identical articles, as described above. Initial Gauge Length=0.5×Initial Gauge Circumference. The final gauge length is calculated from the Full Stretch Circumference which is determined during the Whole Article Force Test, as described above.

Crosshead Speed	254.0 mm/min
Data Acquisition Rate	50 Hz
Final Gauge Length	0.5 × Full Stretch Circumference
Hold Time	0
Number of Cycles	1

[0070] One end of the specimen is clamped into the upper clamp and the load is tared. The other end of the specimen is clamped into the lower clamp. Approximately 5 mm of each end of the specimen is behind the contact line of the grip. The test is started and the specimen is extended to the final gauge length at a crosshead speed of 254 mm/min, then immediately returned to the original gauge length at the same speed. The specimen is extended in the article transverse direction during the test. The unload force at 70% of the Final Gauge Length during the unload segments of the test is recorded.

[0071] Five articles are analyzed and the unload forces are recorded for each of the front and back zones **102, 104, 106, 108**. The average tensile force (N) is calculated to the nearest 0.01 N for each zone including the front and back specimens for that zone. The tensile stress for each zone is calculated by the average tensile force (N) divided by the average specimen width (m) and reported to the nearest 0.1 N/m.

EXAMPLES

Example 1

[0072] A wearable article of the present disclosure having an elastic profiling according to FIGS. **2, 3**, and Table 1 below having an effective belt width LW of 355 mm and a seam length LS of 130 mm.

Example 2

[0073] A wearable article of the present disclosure having an elastic profiling according to FIG. **4**, and Table 1 below having an effective belt width LW of 355 mm and a seam length LS of 130 mm.

Example 3

[0074] A wearable article of the present disclosure having an elastic profiling according to FIG. **5**, and Table 1 below having an effective belt width LW of 355 mm and a seam length LS of 130 mm.

Comparative Example 1

[0075] A wearable article of the prior art having an elastic profiling according to FIGS. **9 and 10**, and Table 1 below having an effective belt width LW of 355 mm and a seam length LS of 130 mm.

TABLE 1

	dtex/elongation %/number of elastic bodies			
	Example 1	Example 2	Example 3	Comparative Example 1
Front waist zone	540dtex/170%/4	940 dtex/210%/3	470 dtex/170%/6	940 dtex/210%/3
Front distal zone	540 dtex/170%/2 and 540 dtex/275%/2 with tummy cut	540 dtex/180%/2 and 540 dtex/180%/2 with tummy cut and 540 dtex/275%/1 with tummy cut	470 dtex/170%/4 and 470 dtex/170%/4 with tummy cut	940 dtex/210%/3 and 680 dtex/275%/1 with tummy cut
Front proximal tummy zone	540 dtex/275%/2 with tummy cut and 940 dtex/275%/6 with tummy cut	540 dtex/275%/1 with tummy cut and 940 dtex/275%/6 with tummy cut	540 dtex/275%/2 and 680 dtex/275%/8 with tummy cut	680 dtex/275%/5 with tummy cut

TABLE 1-continued

	dtex/elongation %/number of elastic bodies			
	Example 1	Example 2	Example 3	Comparative Example 1
Front leg zone with tummy cut	540 dtex/275%/2	540 dtex/150%/4	540 dtex/170%/2	680 dtex/275%/2
Back waist zone	540 dtex/170%/4	940 dtex/210%/3	470 dtex/170%/6	940 dtex/210%/3
Back distal tummy zone	940 dtex/170%/4	1100 dtex/180%/3	680 dtex/170%/6	1100 dtex/170%/3
Back proximal tummy zone	540 dtex/275%/6 with tummy cut	1100 dtex/180%/1 and 540 dtex/275%/4 with tummy cut	470 dtex/275%/8 with tummy cut	680 dtex/275%/4 with tummy cut
Back leg zone	540 dtex/275%/2 with tummy cut	540 dtex/150%/2 with tummy cut	540 dtex/150%/3 with tummy cut	680 dtex/275%/3 with tummy cut

[0076] Elastic bodies indicated as “tummy cut” are removed of elasticity at the central area of the central panels 80 overlapping with the main body 38, and have 66% effective length of elasticity.

[0077] The Waist Circumference Force and tensile stress for each zone are measured according to the Whole Article Force Measurement and Belt Zone Tensile Stress Force Measurement methods herein, respectively, for Example 1 and Comparative Example 1. Results are found in Table 2.

TABLE 2

	Example 1	Comparative Example 1
Waist Circumference Force (N)	6.12	5.99
Tensile Stress (N/m)		
Front waist zone	27.4	30.3
Front distal tummy zone	27.4	29.8
Front proximal tummy zone	107.7	25.7
Front leg zone	19.5	22.1
Back waist zone	28.6	32.0
Back distal tummy zone	49.5	39.4
Back proximal tummy zone	32.5	20.4
Back leg zone	20.5	23.1

[0078] For Examples 1-3, the tensile stress of the front proximal tummy zone 106 is highest among any other zone, and is more than 150% of the tensile stress of the back proximal zone. For Example 1, the tensile stress of the front proximal tummy zone 106 is more than 200% of the tensile stress of the front distal tummy zone 104.

[0079] Also for Examples 1-3, the tensile stress of the front leg zone 108 is no more than 50% of the tensile stress of the front proximal tummy zone 106, and the tensile stress of the back leg zone 108 is no more than 100% of the tensile stress of the back proximal tummy zone 106.

[0080] For Comparative Example 1, the tensile stress of the front proximal tummy zone 106 is lower than the tensile stress of the front distal tummy zone 104, and is less than 150% of the tensile stress of the back proximal zone. Also for Comparative Example 1, the tensile stress of the front leg zone 108 is greater than the tensile stress of the front proximal tummy zone 106, and the tensile stress of the back leg zone 108 is greater than the tensile stress of the back proximal tummy zone 106.

[0081] Example 1 provided profiling of tensile stress per zone without significant increase of total tensile force of the belt compared to Comparative Example 1.

[0082] Compared to Comparative Example 1, Examples 1-3 provide improvement in one or more of: fit, coverage of buttock area, comfort during wear, prevention of sagging, prevention of leakage, fit around waist, softness of inside of the belt, prevention of red marking, overall softness, looking soft, and perceived overall quality.

Consumer Acceptance

[0083] Example 1 and Comparative Example 1 including an identical absorbent core are subjected to a consumer test for application on 50 panelists and 51 panelists, respectively. The panelists are caregivers of Japanese Size 4 (L-size) wearers of age 0-36 months, and at about the same boy/girl ratio. The caregivers of the panelists are given enough products to use either product for 5 days, and then answer a questionnaire including the following questions, and asked to rate the performance in 5 scales from “Very Poor” to “Excellent”, wherein 100 represents “Excellent”, 75 represents “Good”, 50 represent “Fair”, 25 represent “Poor” and 0 represents “Very Poor”. The ratings are averaged and statistically analyzed. Test results are shown below in Table 3.

TABLE 3

Question	Example 1	Comparative Example 1
Overall Rating	77*	69
Overall Softness	86*	71
Belt Softness	79	70
Overall Fit Of The Pant When The Diaper Is Full	72	64
Overall Quality Of The Product	80*	71
Preventing Skin Problems Such As Rash/Redness/Would Cause You Concern	70	62
Preventing Diaper Dropping & Sagging That Would Cause You Concern	76	71

*Statistically significant over Comparative Example 1 with 90% confidence level

[0084] According to the consumer acceptance test results, Example 1 of the present disclosure, compared to Comparative Example 1, is accepted better in all aspects of the

product listed above, and is statistically significantly better accepted in many aspects of the product. In particular, Example 1 is significantly conceived better in “Overall Rating”, “Overall Softness”, and “Overall quality of the product”.

[0085] The dimensions and values disclosed herein are not to be understood as being strictly limited to the exact numerical values recited. Instead, unless otherwise specified, each such dimension is intended to mean both the recited value and a functionally equivalent range surrounding that value. For example, a dimension disclosed as “40 mm” is intended to mean “about 40 mm.”

[0086] Every document cited herein, including any cross referenced or related patent or application, is hereby incorporated herein by reference in its entirety unless expressly excluded or otherwise limited. The citation of any document is not an admission that it is prior art with respect to any invention disclosed or claimed herein or that it alone, or in any combination with any other reference or references, teaches, suggests or discloses any such invention. Further, to the extent that any meaning or definition of a term in this document conflicts with any meaning or definition of the same term in a document incorporated by reference, the meaning or definition assigned to that term in this document shall govern.

[0087] While particular embodiments of the present disclosure have been illustrated and described, it would be obvious to those skilled in the art that various other changes and modifications can be made without departing from the spirit and scope of the invention. It is therefore intended to cover in the appended claims all such changes and modifications that are within the scope of this invention.

What is claimed is:

1. An absorbent article, comprising:

a main body and a ring-like elastic belt comprising a front belt and a back belt, wherein the front belt is joined to a front waist panel of the main body, and the back belt is joined to a back waist panel of the main body, wherein the front and back belts each having a left side panel and a right side panel, and wherein transverse edges of the front belt and the back belt are joined by first and second seams to form a waist opening and two leg openings;

wherein each of the front belt and back belt formed by a plurality of elastic bodies running in the transverse direction sandwiched between an inner sheet and an outer sheet; each front belt and back belt having transversely continuous proximal and distal edges, the proximal edge being located closer than the distal edge relative to the longitudinal center of the article;

wherein each of the proximal edges and the distal edges of the front belt and the back belt are substantially parallel, the longitudinal length of the back belt being longer than that of the front belt, wherein the distal edge of the front belt is aligned with the distal edge of the back belt, and the proximal edge of the front belt is not aligned with the proximal edge of the back belt;

wherein all of the elastic bodies disposed in the back belt are arranged in at least 5 arrays, the at least 5 arrays meeting a), b), and c) as follows:

a) one array is formed by 2 elastic bodies;
b) each elastic body within the one array (of clause a) above) is disposed in an inner-interval in the longitudinal direction between each elastic body of 2-4 mm; and

c) one specific array, outside of and separate from the one array, disposed in an extra-interval in the longitudinal direction between at least one neighboring elastic bodies outside the specific array of greater than the inner-interval;

wherein all of the elastic bodies disposed in the front and back belts extend in the transverse direction substantially parallel to each other;

wherein the entirety of the length of the belt side edge of the front belt is seamed with a certain length of the belt side edge of the back belt to define a seam length LS; wherein the front and back belts are each divided into 4 zones extending in the transverse direction and defined by its location from the distal edge to the proximal edge relative to the percentage of the seam length LS wherein 0-25% is the waist zone, 25-50% is the distal tummy zone, 50-85% is the proximal tummy zone, and 85-100% is the leg zone; and

wherein the tensile stress of the front leg zone is no more than 50% of the tensile stress of the front proximal tummy zone.

2. The wearable article of claim 1, wherein the elastic bodies of the array are disposed at the same density and the same elongation.

3. The wearable article of claim 2, wherein all of the elastic bodies disposed on the front belt are arranged in arrays.

4. The absorbent article of claim 1, wherein all of the elastic bodies disposed in the back belt are arranged in the at least 5 arrays.

5. The absorbent article of claim 1, wherein each of the 5 arrays is a basic array that meets requirements a), b), and c), each basic array being disposed at a distance of 8-22 mm in the longitudinal direction from an adjacent basic array.

6. The absorbent article of claim 1, wherein the elastic bodies of the one array has a density of no more than 940 dtex.

7. The absorbent article of claim 1, wherein the elastic bodies of the one array are disposed at an elongation of from 100% to 350%.

8. The absorbent article of claim 1, wherein the elastic belt comprises no more than 60 elastic bodies.

9. The absorbent article of claim 1, wherein the article has a Waist Circumference Force according to the Whole Article Force Measurement herein of no more than 10N.

10. The absorbent article of claim 9, wherein the tensile stress of the front proximal tummy zone is higher than the tensile stress of any other zone.

11. The absorbent article of claim 9, wherein the tensile stress of the front distal tummy zone is lower than the tensile stress of the back distal tummy zone.

12. The absorbent article of claim 1, wherein the proximal edges and the distal edges of the front belt and the back belt are substantially parallel.

13. The absorbent article of claim 12, wherein the longitudinal length of the back belt is longer than that of the front belt.

14. The absorbent article of claim 13, wherein the distal edge of the front belt is aligned with the distal edge of the back belt.

15. The absorbent article of claim 14, wherein the proximal edge of the front belt is not aligned with the proximal edge of the back belt.

16. The absorbent article of claim 1, wherein at least a portion of the elasticity of at least one of the elastic bodies is removed in the region overlapping with the front and back waist panels of the main body.

17. The absorbent article of claim 1, wherein the tensile stress of the back leg zone is no more than 100% of the tensile stress of the back proximal tummy zone.

18. The absorbent article of claim 1, wherein the front belt comprises at least 3 arrays that meet requirements a), b), and c).

* * * * *