



US010833018B2

(12) **United States Patent**  
**Rashed et al.**

(10) **Patent No.:** **US 10,833,018 B2**  
(45) **Date of Patent:** **Nov. 10, 2020**

(54) **SEMICONDUCTOR DEVICE WITH TRANSISTOR LOCAL INTERCONNECTS**

(71) Applicant: **GLOBALFOUNDRIES INC.**, Grand Cayman (KY)

(72) Inventors: **Mahbub Rashed**, Santa Clara, CA (US); **Irene Y. Lin**, Los Altos Hills, CA (US); **Steven Soss**, Cornwall, NY (US); **Jeff Kim**, San Jose, CA (US); **Chinh Nguyen**, Austin, TX (US); **Marc Tarabbia**, Pleasant Valley, NY (US); **Scott Johnson**, Wappingers Falls, NY (US); **Subramani Kengeri**, San Jose, CA (US); **Suresh Venkatesan**, Danbury, CT (US)

(73) Assignee: **GLOBALFOUNDRIES INC.**, Grand Cayman (KY)

(\* ) Notice: Subject to any disclaimer, the term of this patent is extended or adjusted under 35 U.S.C. 154(b) by 0 days.

(21) Appl. No.: **16/502,521**

(22) Filed: **Jul. 3, 2019**

(65) **Prior Publication Data**  
US 2019/0326219 A1 Oct. 24, 2019

**Related U.S. Application Data**  
(60) Continuation of application No. 15/164,114, filed on May 25, 2016, now abandoned, which is a division of (Continued)

(51) **Int. Cl.**  
**H01L 23/535** (2006.01)  
**H01L 21/8234** (2006.01)  
(Continued)

(52) **U.S. Cl.**  
CPC ..... **H01L 23/535** (2013.01); **H01L 21/28518** (2013.01); **H01L 21/76895** (2013.01);  
(Continued)

(58) **Field of Classification Search**  
None

See application file for complete search history.

(56) **References Cited**

U.S. PATENT DOCUMENTS

7,917,879 B2 3/2011 Becker et al.  
8,049,334 B1 11/2011 Halliyal et al.  
(Continued)

FOREIGN PATENT DOCUMENTS

CN 1725499 A 1/2006  
KR 10-1998-052466 9/1998  
KR 10-2004-0074261 8/2004

OTHER PUBLICATIONS

State Intellectual Property Office of the People's Republic of China, First Office Action for Chinese Patent Application No. 201210539484.8, dated Jan. 6, 2015.

(Continued)

*Primary Examiner* — Cory W Eskridge

(74) *Attorney, Agent, or Firm* — Francois Pagette; Hoffman Warnick LLC

(57) **ABSTRACT**

A semiconductor device includes a substrate with first and second transistors disposed thereon and including sources, drains, and gates, wherein the first and second gates extend longitudinally as part of linear strips that are parallel to and spaced apart. The device further includes a first CB layer forming a local interconnect electrically connected to the first gate, a second CB layer forming a local interconnect electrically connected to the second gate, and a CA layer forming a local interconnect extending longitudinally between first and second ends of the CA layer. The first and second CB layers and the CA layer are disposed between a first metal layer and the substrate. The first metal layer is disposed above each source, drain, and gate of the transistors. The CA layer extends parallel to the first and second

(Continued)

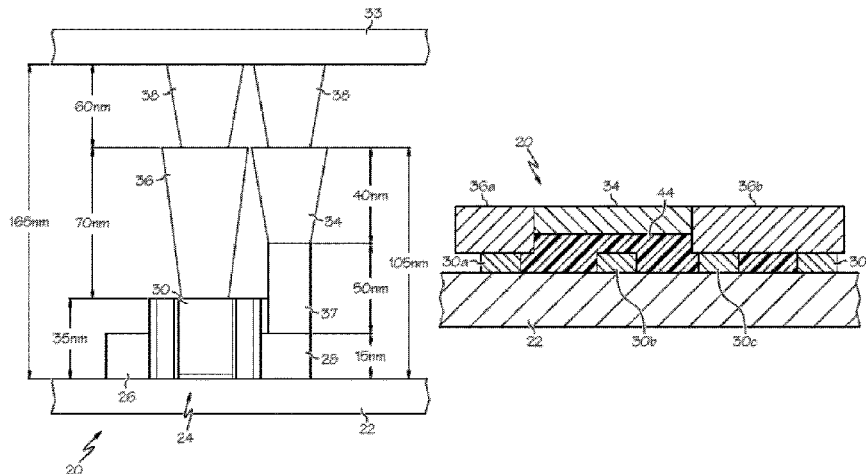

linear strips and is substantially perpendicular to the first and second CB layers.

**20 Claims, 7 Drawing Sheets**

**Related U.S. Application Data**

application No. 13/324,740, filed on Dec. 13, 2011, now Pat. No. 9,355,910.

(51) **Int. Cl.**

*H01L 27/02* (2006.01)  
*H01L 21/768* (2006.01)  
*H01L 21/285* (2006.01)  
*H01L 21/8238* (2006.01)  
*H01L 23/532* (2006.01)  
*H01L 27/092* (2006.01)  
*H01L 29/08* (2006.01)  
*H01L 27/118* (2006.01)

(52) **U.S. Cl.**

CPC ..... *H01L 21/823418* (2013.01); *H01L 21/823475* (2013.01); *H01L 21/823814* (2013.01); *H01L 21/823871* (2013.01); *H01L 23/53238* (2013.01); *H01L 27/0207* (2013.01); *H01L 27/092* (2013.01); *H01L 29/0847* (2013.01); *H01L 27/11807* (2013.01); *H01L 2924/0002* (2013.01)

(56)

**References Cited**

U.S. PATENT DOCUMENTS

2003/0003640	A1	1/2003	Lee	
2004/0021226	A1	2/2004	Geffken et al.	
2004/0097021	A1	5/2004	Augusto et al.	
2006/0019488	A1	1/2006	Liaw	
2007/0141834	A1	6/2007	Kwon et al.	
2008/0179676	A1	7/2008	Hirano et al.	
2009/0224317	A1*	9/2009	Becker .....	G06F 30/39 257/337
2012/0292704	A1	11/2012	Anderson	

OTHER PUBLICATIONS

State Intellectual Property Office of the People's Republic of China, Third Office Action for Chinese Patent Application No. 201210539484.8, dated Mar. 23, 2016.  
 Office Action prepared by the German Patent Office dated Dec. 20, 2012 in German Patent Application No. 10 2012 219 375.8. (English translation).  
 Korean Intellectual Property Office, Notice of Office Action for Korean Patent Application No. 10-2012-0109233 dated May 26, 2015.  
 Intellectual Property Office, Examination Report for Taiwanese Patent Application No. 101126924, dated Sep. 9, 2014.  
 Intellectual Property Office, Examination Report for Taiwanese Patent Application No. 101126924, dated May 25, 2015.  
 Intellectual Property Office, Office Action for German Patent Application No. 10 2012 219 375.8, dated Jul. 17, 2018 and English Translation of Official Communication.

\* cited by examiner

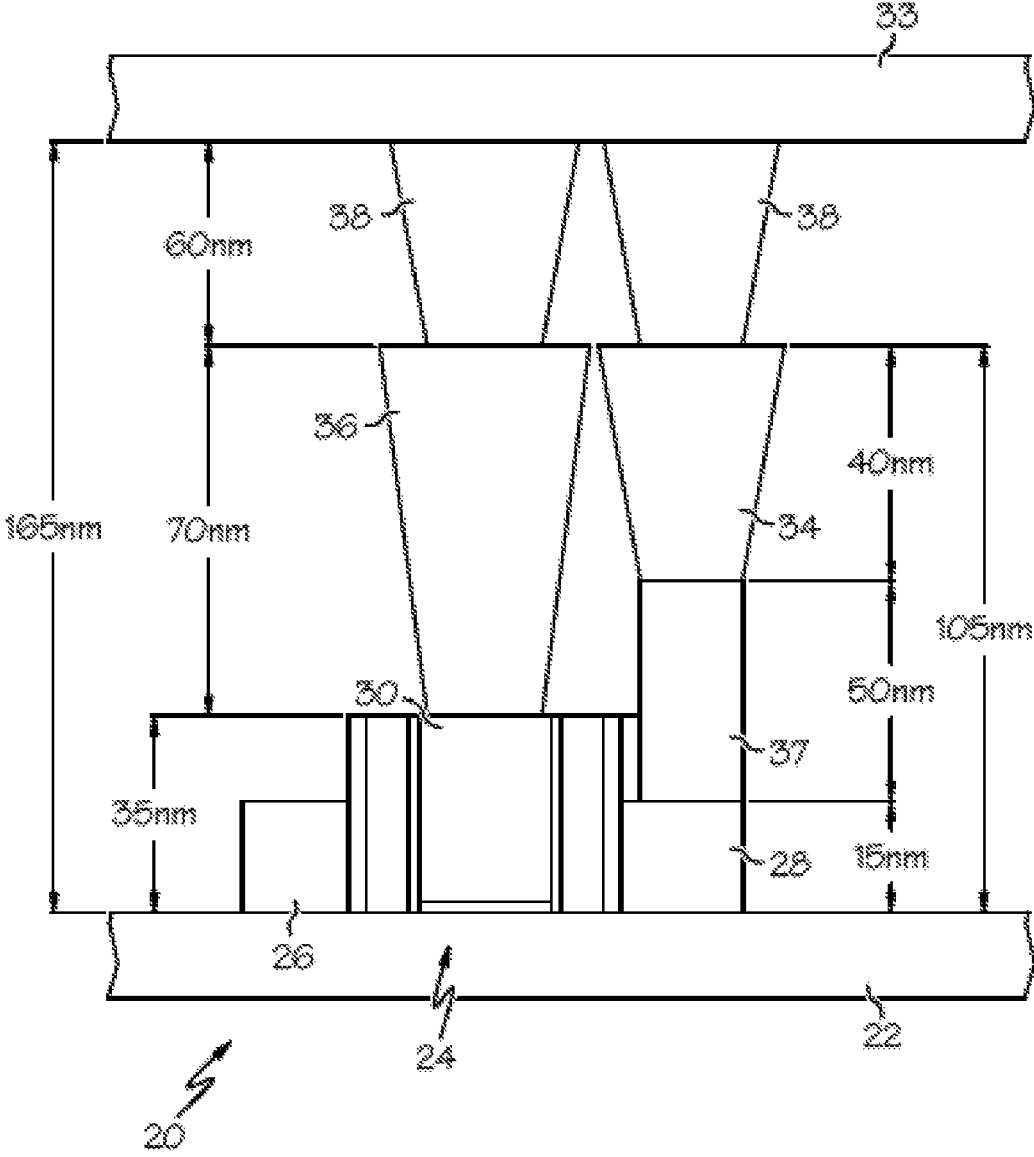

FIG. 1

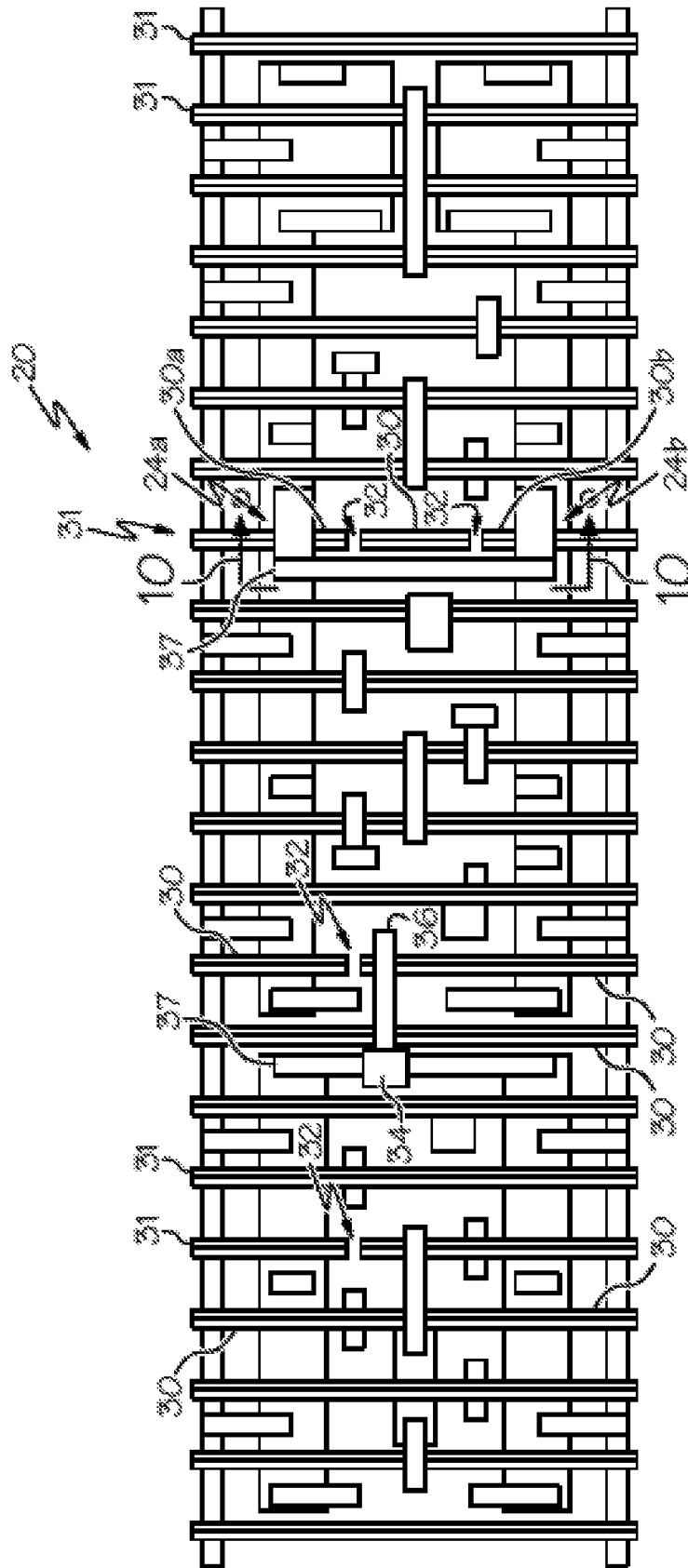
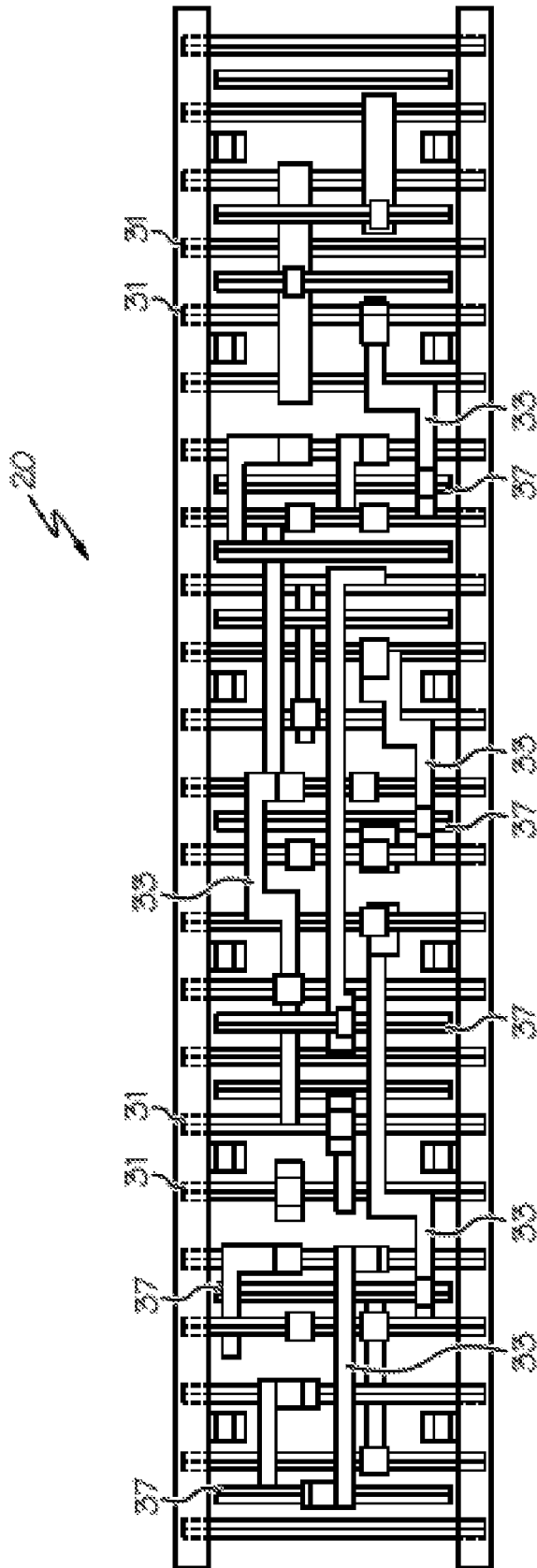

FIG. 2



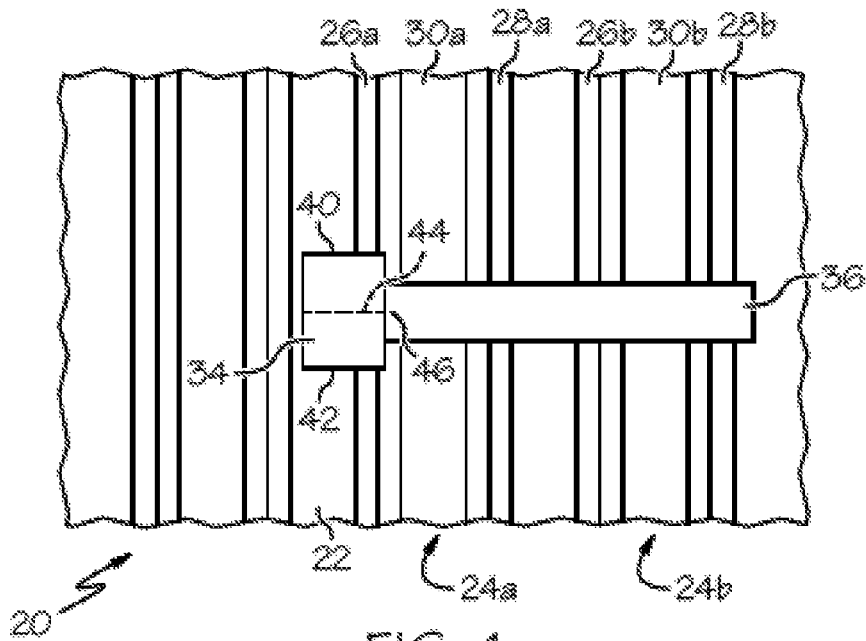

FIG. 4

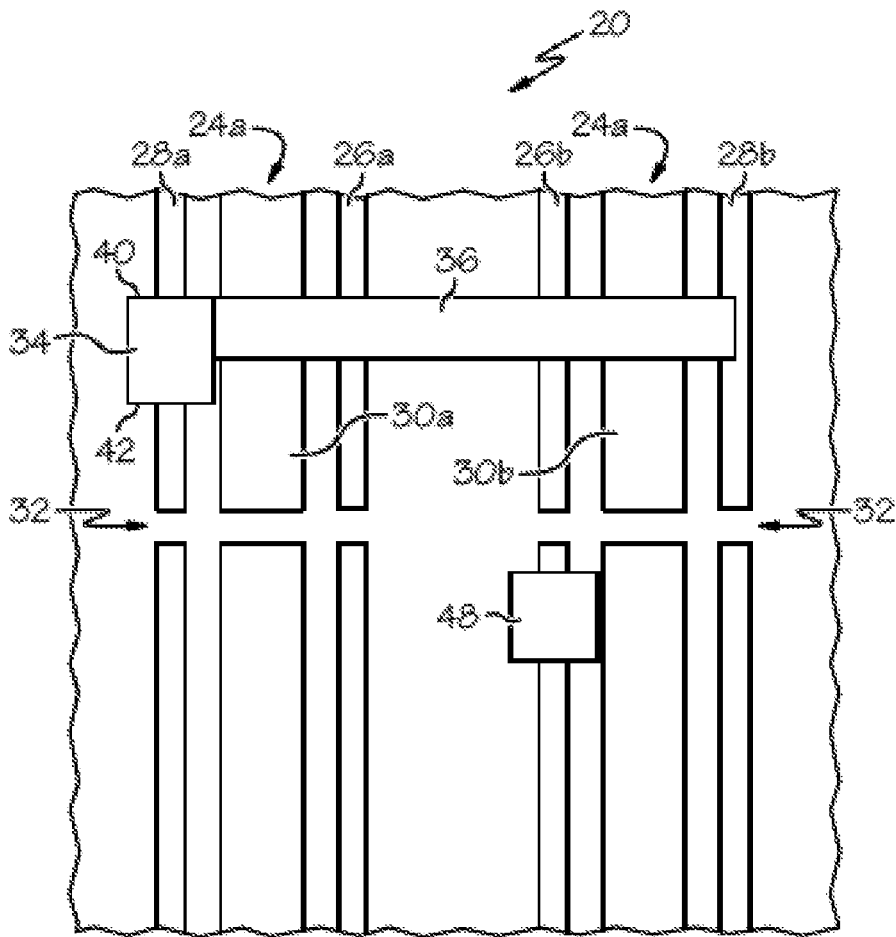

FIG. 5

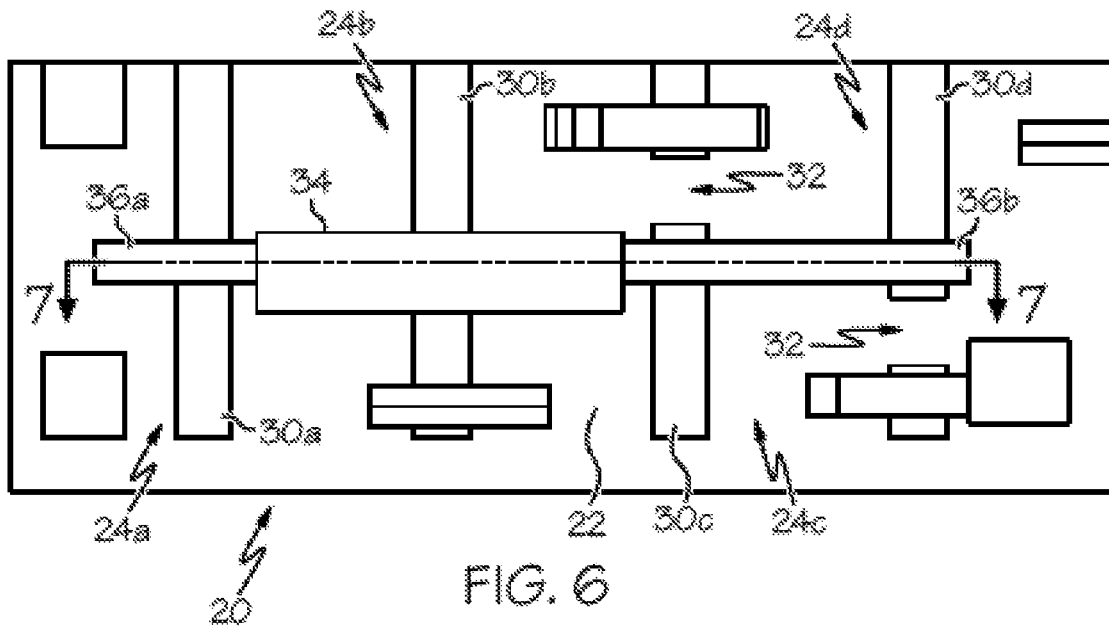

FIG. 6

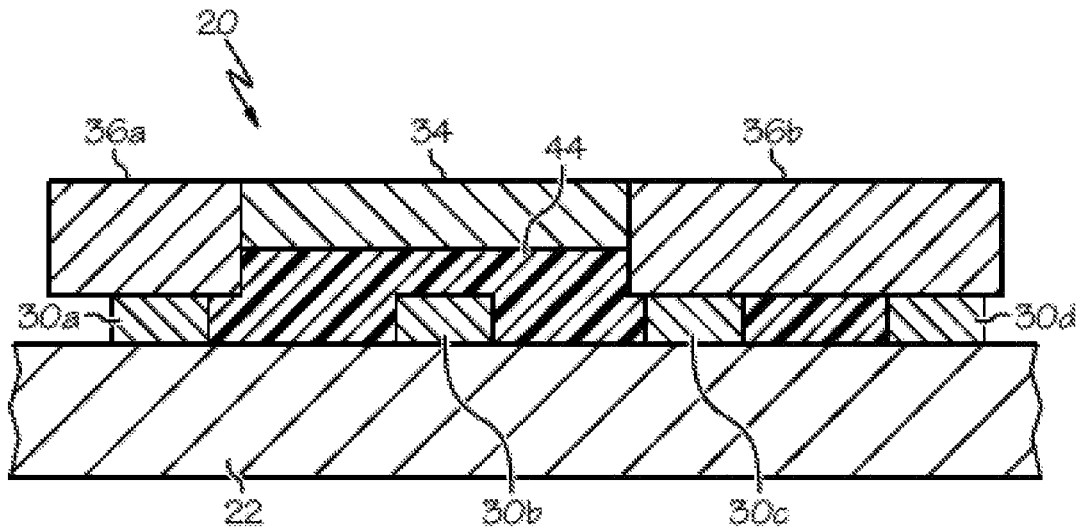

FIG. 7

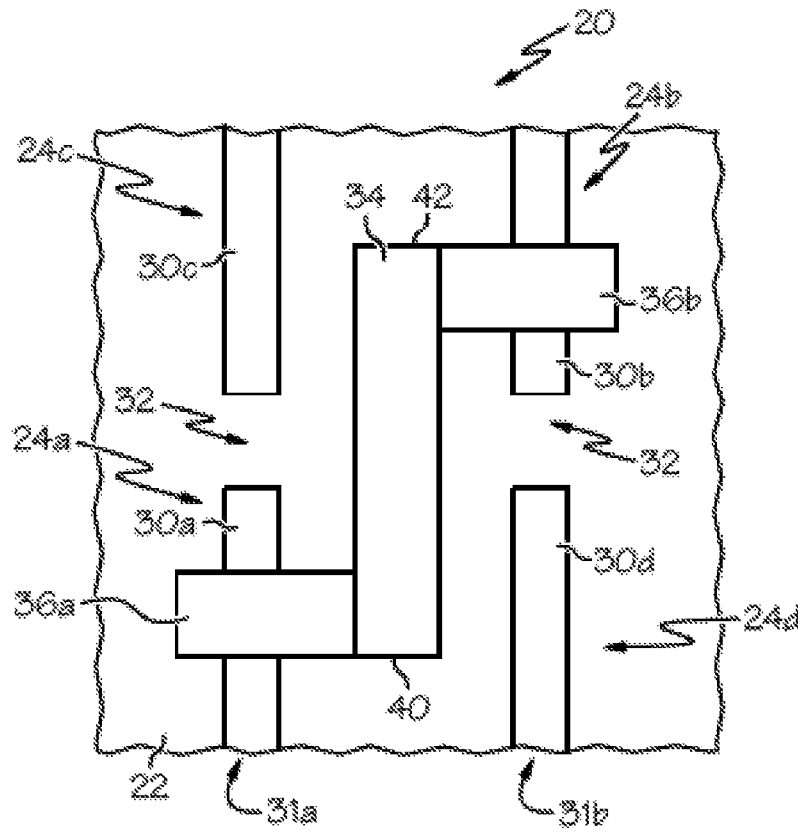

FIG. 8

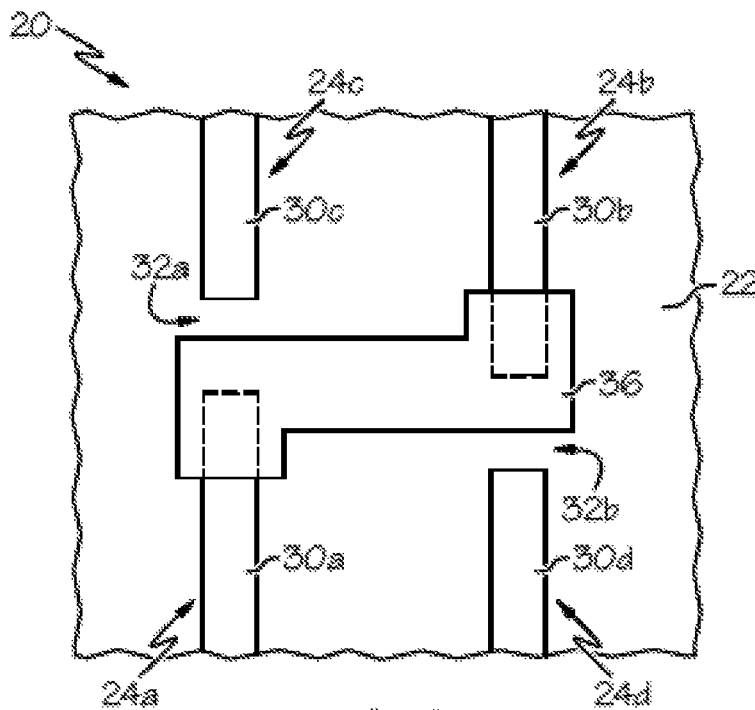

FIG. 9



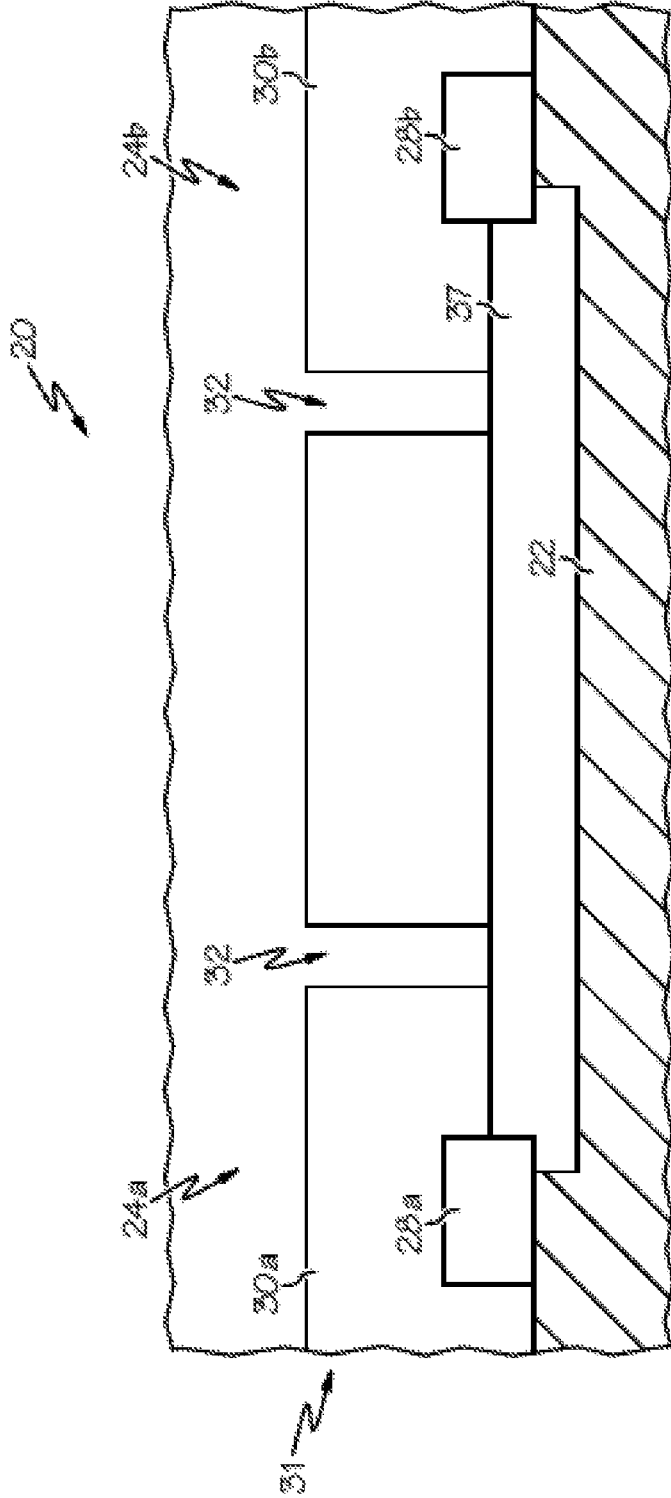

FIG. 10

## SEMICONDUCTOR DEVICE WITH TRANSISTOR LOCAL INTERCONNECTS

### CROSS-REFERENCE TO RELATED APPLICATIONS

This application is a continuation of application Ser. No. 15/164,114 filed on May 25, 2016, which was a divisional of application Ser. No. 13/324,740 filed on Dec. 13, 2011.

### FIELD OF THE INVENTION

The present invention generally relates to semiconductor devices, and more particularly relates to local interconnects between transistors in semiconductor devices.

### BACKGROUND OF THE INVENTION

As the size of semiconductor devices continues to decrease, the ability to create standard cell library logic devices, such as scan-D flip-flops and multiplexers, becomes more difficult. This is particularly the case at the 20 nm node, where lithographic limitation results in a lack of scaling of standard cell library devices. Cross-coupling of transistors is critical to the scaling of key stand cell library devices. Without cross-coupling, logic scaling will take up more area of the semiconductor device. Furthermore, traditional cross-coupling utilizing a standard metal layer will also occupy large amounts of area. Either of these conditions is obviously undesirable, leading to a larger semiconductor device or less functionality in the semiconductor device.

Accordingly, it is desirable to provide cross-coupling of transistors without reliance on a standard metal layer to produce standard cell library devices while conserving semiconductor device area. Furthermore, other desirable features and characteristics of the present invention will become apparent from the subsequent detailed description of the invention and the appended claims, taken in conjunction with the accompanying drawings and this background of the invention.

### BRIEF SUMMARY OF THE INVENTION

A semiconductor device includes a substrate, a first and second transistor disposed on the substrate and including a source, drain, and gate, wherein the first gate extends longitudinally as part of a first linear strip and wherein the second gate extends longitudinally as part of a second linear strip parallel to and spaced apart from the first linear strip. The device further includes a first CB layer forming a local interconnect layer electrically connected to the gate of the first transistor, a second CB layer forming a local interconnect layer electrically connected to the gate of the second transistor, and a CA layer forming a local interconnect layer extending longitudinally between first and second ends of the CA layer. The CA layer is electrically connected to the first and second CB layers. The first CB layer is electrically connected adjacent the first end of the CA layer and the second CB layer is electrically connected adjacent the second end of the CA layer. The first CB layer, the second CB layer, and the CA layer are disposed between a first metal layer and the substrate. The first metal layer is disposed above each source, each drain, and each gate of the first and second transistors, The CA layer extends generally parallel to the first and second linear strips and is substantially perpendicular to the first and second CB layers.

A semiconductor device is provided for implementing at least one logic element. In one aspect of the invention, the semiconductor device includes a semiconductor substrate with a first transistor and a second transistor formed on the semiconductor substrate. Each of the transistors comprises a source, a drain, and a gate. A trench silicide layer electrically connects one of the source or the drain of the first transistor to one of the source or the drain of the second transistor.

In another aspect of the invention, the semiconductor device includes a semiconductor substrate with a first transistor and a second transistor disposed on the substrate. Each of the transistors comprises a source, a drain, and a gate. A first CB layer is electrically connected to the gate of the first transistor. A second CB layer is electrically connected to the gate of the second transistor. A CA layer extends longitudinally between a first end and a second end. The first CB layer is electrically connected adjacent the first end of the CA layer. The second CB layer is electrically connected adjacent the second end of the CA layer.

In yet another aspect of the invention, a semiconductor device includes a semiconductor substrate with a first transistor and a second transistor disposed on the substrate. Each of the transistors comprises a gate, wherein the gates extend longitudinally and generally parallel to one another. A CB layer electrically connects the gates of the first and second transistors and forms a zig-zag shape.

### BRIEF DESCRIPTION OF THE DRAWINGS

The present invention will hereinafter be described in conjunction with the following drawing FIG.s, wherein like numerals denote like elements, and

FIG. 1 is a cross-sectional side view of a portion of a semiconductor device;

FIG. 2 is a top view of one embodiment of the semiconductor device showing gates of transistors, various local interconnect layers, and trench silicide layers;

FIG. 3 is a top view of another embodiment of the semiconductor device showing a metal layer disposed above the gates of the transistors and the various local interconnect layers;

FIG. 4 is a top view of a portion of a first embodiment of the semiconductor device;

FIG. 5 is a top view of a portion of a second embodiment of the semiconductor device;

FIG. 6 is a top view of a portion of a fourth embodiment of the semiconductor device;

FIG. 7 is a cross-sectional side view the fourth embodiment of the semiconductor according to the line 7-7 shown in shown in FIG. 6;

FIG. 8 is a top view of a portion of a fifth embodiment of the semiconductor device;

FIG. 9 is a top view of a portion of a sixth embodiment of the semiconductor device; and

FIG. 10 is a side view of a portion of a seventh embodiment of the semiconductor device according to the line 10-10 shown in FIG. 2.

### DETAILED DESCRIPTION

The following detailed description of the invention is merely exemplary in nature and is not intended to limit the invention or the application and uses of the invention. Furthermore, there is no intention to be bound by any theory presented in the preceding background of the invention or the following detailed description of the invention.

Referring to the figures, wherein like numerals indicate like parts throughout the several views, a semiconductor device 20 is shown and described herein. The semiconductor device 20 may be part of an integrated circuit (not separately numbered) as is well recognized by those skilled in the art.

Referring to FIG. 1, the semiconductor device 20 includes a semiconductor substrate 22. The semiconductor device 20 includes a plurality of transistors 24. Specifically, in the illustrated embodiments, the transistors 24 are field-effect transistors (FETs) and more specifically, metal-oxide-semiconductor field-effect transistors (MOSFETs). Each of the transistors 24 includes a source 26, a drain 28, and a gate 30.

The sources 26 and drains 28 are formed in and/or on the substrate 22 using techniques that are well known to those skilled in the art. In the illustrated embodiments, the sources 26 and drains 28 are formed as raised sources 26 and drains 28, i.e., at least a portion of the sources 26 and drains 28 are formed above the substrate 22. In the configuration shown in FIG. 1, the raised source 26 and drain 28 each extend about 15 nm above the substrate 22. However, other dimensions may be alternatively realized. The raised sources 26 and drains 28 may be formed using embedded silicon germanium (eSiGe) techniques as is appreciated by those skilled in the art. Of course, other techniques may be implemented to form the raised sources 26 and drains 28. Furthermore, in other embodiments (not shown), the sources 26 and drains 28 may not be raised above the substrate 22.

The gates 30 are typically formed above the substrate 22 using techniques well known to those skilled in the art. In the illustrated embodiments, the gates 30 are formed primarily of polycrystalline silicon, commonly referred to as polysilicon or simply PolySi, disposed above the substrate 22. However, the gates 30 may also be formed from other materials, e.g., a high- $\kappa$  metal. In the configuration shown in FIG. 1, the gate 30 extends about 35 nm above the substrate 22. However, other dimensions for the gates 30 may be alternatively realized.

As can be seen with reference to FIG. 2, the gates 30 are formed as linear strips 31 generally parallel to one another. Gaps 32 may be formed in the strips 31 such that more than one transistor 30 may be disposed longitudinally along each strip 31. Such gaps 32 may be formed using cut mask techniques as readily appreciated by those skilled in the art.

Referring to FIGS. 1 and 3, the semiconductor device 20 includes at least one metal layer 33 disposed above the sources 26, drains 28, and gates 30 of the transistors 24 as is appreciated by those skilled in the art. The metal layers 33 facilitate electrical communication between the various logic elements of the device 20 and other logic elements of the device 20 as well as other systems apart from the device 20. The metal layers 33 are routinely labeled and referred to as M1, M2, etc., as is also appreciated by those skilled in the art. In the configuration shown in FIG. 1, one metal layer 33 is disposed about 165 nm above the substrate 22. However, other distances and dimensions for the metal layer 33 may be alternatively realized.

The semiconductor device 20 further includes at least one local interconnect layer 34, 36 to selectively connect the sources 26, drains 28, and gates 30 of the transistors 24 to other sources 26, drains 28, and gates 30 of other transistors 24. The at least one local interconnect layer 34, 36 may also be selectively connected to the at least one metal layer 33. The at least one local interconnect layer 34, 36 is disposed between the at least one metal layer 33 and the substrate 22. Said another way, the metal layer 33 is disposed above the at least one local interconnect layer 34, 36 with respect to the substrate 22. The at least one local interconnect layer 34 of

the illustrated embodiments is formed primarily of tungsten. In other embodiments, the at least one local interconnect layer 34, 36 is formed primarily of copper. However, the local interconnect layers 34, 36 may be formed of or include other elements or compounds.

Various embodiments of the semiconductor device 20 showing different shapes, arrangements, and electrical connections of the at least one local interconnect layer 34, 36 are shown in the various figures and described below. A first local interconnect layer 34 is referred to herein as a CA layer 34 and a second local interconnect layer 36 is referred to herein as a CB layer 36. Of course, multiple CA layers 34 and multiple CB layers 36 may be implemented in the semiconductor device 20 and other local interconnect layers (not shown) may also be implemented. Typically, the CA layer(s) 34 electrically connect to sources 26 or drains 28 while the CB layer(s) 36 electrically connect to gates 30. However, such typical configuration should certainly not be viewed as limiting. In fact, in some of the embodiments described below, CA layer(s) 34 and/or CB layer(s) 36 may not be connected to sources 26, drains 28, or gates 30.

The use of the CA and CB layers 34, 36 in the illustrated embodiments may be utilized to produce a variety of standard cells, such as, for example, scan-D flip-flops. In the prior art, a metal layer is typically utilized in to provide the connection for scan-D flip-flops. By utilizing the CA and CB layers 34, 36, which are disposed closer to the substrate than the typical metal layer, the resulting scan-D flip-flops have a reduced area when compared to prior art devices.

The semiconductor device 20 may further include one or more trench silicide layers 37. The trench silicide layer 37 may be utilized to electrically connect the source 26 and/or drain 28 of the transistor 24 to one of the CA or CB layers 34, 36, and typically the CA layer, as shown in FIG. 1. As such, the trench silicide layer 37 is sandwiched between one of the CA or CB layers 34, 36 and the at least one of the source 26 or the drain 28 of the transistor 24. The trench silicide layer 37 is formed by cutting a trench (not separately numbered) in a dielectric (not shown) to the depth of the substrate 22 and filling the trench with a silicide material. For example, the silicide material may be a metal, such as nickel, cobalt, or tungsten.

The trench silicide layer 37 of the configuration shown in FIG. 1 has a height of about 50 nm. The CA layer 34 of FIG. 1 is supported by the trench silicide layer 34 and has a height of about 40 nm. The CB layer 36 of FIG. 1 has a height of about 70 nm. The CA layer 34 and CB layer 36 of FIG. 1 are generally level with one another with respect to the substrate 22. Furthermore, as can be seen in FIG. 1, the CA and CB layers 34, 36 of the illustrated embodiments do not extend more than 105 nm above the substrate 22. Of course, the heights and dimensions of the trench silicide layer 37, the CA layer 34, and the CB layer 36 may be different in alternative embodiments depending on any number of factors.

The semiconductor device 20 may include a plurality of vias 38 to selectively provide electrical connections between the CA or CB layers 34, 36 and the at least one metal layer 33. As such, one of the vias 38 may be disposed between the at least one metal layer 33, and one of the CA or CB layers 34, 36. The vias 38 are formed primarily of a metal, such as copper. However, other metals or electrically conductive materials may also be suitable. The vias 38 of the configuration shown in FIG. 1 have a height of about 60 nm.

In a first embodiment, as shown in FIG. 4, the semiconductor device 20 includes at least a first transistor 24a and a second transistor 24b. The semiconductor device 20 includes a CA layer 34 and a CB layer 36. The CA layer 34

is electrically connected to at least one of the source **26a** or the drain **28a** of the first transistor **24a**. A CB layer **36** is electrically connected to at least one of the gates **30** of the transistors **24a**, **24b**. Depending on the particular application, the CB layer **36** may be electrically connected to both of the gates **30** of the transistors **24a**, **24b**. The first and CB layers **34**, **36** are also electrically connected to one another.

In the first embodiment, the CA layer **34** extends between a first end **40** and a second end **42**. The CB layer **36** is disposed generally at a center **44** of the CA layer **34** between the ends **40**, **42**. More specifically, an end **46** of the CB layer **36** is disposed generally at the center **44** of the CA layer **34**. As such, when viewed from above, the first and CB layers **34**, **36** form a long ‘T’ shape.

A second embodiment of the semiconductor device **20**, is substantially similar to the first embodiment, but further includes a trench silicide layer **37** disposed between the CA layer **34** at least one of the source **26** or the drain **28** of the first transistor **24a**. Such an arrangement can be seen with reference again to FIG. 1.

In a third embodiment, as shown in FIG. 5, the semiconductor device **20** includes at least the first transistor **24a** and the second transistor **24b**. The semiconductor device **20** includes a first CA layer **34a** and a CB layer **36**. The first CA layer **34a** is electrically connected to at least one of the source **26a** or the drain **28a** of the first transistor **24a**. The CB layer **36** is electrically connected to at least one of the gates **30a**, **30b** of the transistors **24a**, **24b**. Depending on the particular application, the CB layer **36** may be electrically connected to both of the gates **30a**, **30b** of the transistors **24a**, **24b**. The first and CB layers **34**, **36** are also electrically connected to one another.

In the third embodiment, like the first embodiment, the CA layer **34** extends between the first end **40** and the second end **42**. However, in the third embodiment, the CB layer **36** is disposed adjacent one of the ends **40**, **42**. As such, when viewed from above, the first and CB layers **34**, **36** form a long ‘L’ shape. The long ‘L’ shape of the third embodiment allows the CB layer **36** to be disposed apart from a second CA layer **48** to prevent electrical conductivity between the CB layer **36** and the second CA layer **48**.

Referring to FIGS. 6 and 7, a fourth embodiment of the semiconductor device **20** includes a first transistor **24a**, a second transistor **24b**, and a third transistor **24c** formed on the substrate **22**. The transistors **24** are disposed sequentially from the first transistor **24a** through the third transistor **24c**. The device **20** may further include a fourth transistor **24d** wherein the transistors **24** are disposed sequentially from the first transistor **24a** through the fourth transistor **24d**.

A first CB layer **36a** is electrically connected to the gate **30a** of the first transistor **24a** and a second CB layer **36b** is electrically connected to the gate **30c** of the third transistor **24c**. A CA layer **34** electrically connects the first CB layer **36a** and the second CB layer **36b** to one another. As such, the gate **30** of the first transistor **24a** and the gate **30c** of the third transistor **24c** are electrically connected to one another through the CB layers **36a**, **36b** and the CA layer **34**.

The CA layer **34** is electrically insulated from the gate **30b** of the second transistor **24b**. As such, the CA layer **34** forms a “bridge” or a “jumper” over the gate **30b** of the second transistor **24b**. One or more insulating layers **44** may be sandwiched between the CA layer **34** and the gate **30** of the second transistor **24b**. The one or more insulating layers **44** may also be sandwiched between the CA layer **36** and the substrate **22**.

Depending on the particular logic element needs, the second CB layer **36b** may also be electrically connected to

the gate **30** of the fourth transistor **24d**. Furthermore, the CA layer **34** may also be electrically connected to at least one of the source **26** or the drain **28** of one of the transistors **24a**, **24b**, **24c**. As is shown in FIGS. 6 and 7, the CA layer **34** and the CB layers **34a**, **34b** are disposed above the gates **30** of the transistors **24a**, **24b**, **24c**, **24d** with respect to the substrate **22**.

In a fifth embodiment, the semiconductor device **20** includes a semiconductor substrate **22** with a first transistor **24a** and a second transistor **24b** disposed on the substrate **22**, as illustrated in FIG. 8. A first CB layer **36a** is electrically connected to the gate **30a** of the first transistor **24a** and a second CB layer **36b** is electrically connected to the gate **30a** of the second transistor **24b**. A CA layer **34** extends longitudinally between a first end **40** and a second end **42**. The first CB layer **36a** is electrically connected to the CA layer **34** adjacent the first end **40** of the CA layer **34**. The second CB layer **36b** is electrically connected to the CA layer **34** adjacent the second end **42** of the CA layer **34**.

The gate **30a** of the first transistor **24a** extends longitudinally as part of a first linear strip **31a** and the gate **30b** of the second transistor **24b** extends longitudinally as part of a second linear strip **31b**. The first and second strips **31a**, **31b** are generally parallel to one another and spaced apart from one another. The CA layer **34** is generally perpendicular to the first and second CB layers **36a**, **36b**. As such, the CA layer **34** extends generally parallel to the strips **31a**, **31b** and is disposed between the strips **31a**, **31b**. Accordingly, the CA layer **34** and the CB layers **36a**, **36b** collectively form a zig-zag or generally S-shape when viewed from above.

The semiconductor device **20** of the fifth embodiment may further include a third transistor **24c** and a fourth transistor **24d**. The gate **30c** of the third transistor **24c** extends longitudinally as part of the first strip **31a** and the gate **30d** of the fourth transistor **24d** extends longitudinally as part of the second strip **31b**. A gap **32** separates the gate **30a** of the first transistor **24a** from the gate **30c** of the third transistor **24c** and the gate **30** of the second transistor **24b** from the gate **30** of the fourth transistor **24d**. As such, the gates **30** of the first and second transistors **24a**, **24b** are cater-corner from one another and that the CA layer **34** extends across the gap **32**.

In a sixth embodiment, as shown in FIG. 9, the semiconductor device **20** includes a semiconductor substrate **22** with a first transistor **24a** and a second transistor **24b** disposed on the substrate **22**. The gates **30a**, **30b** of the transistors **24a**, **24b** extend longitudinally and generally parallel to one another. The first gate **30a** is formed as part of a first linear strip **31a** and the second gate **30b** is formed as part of second linear strip **31b**. A single CB layer **36** is electrically connected to both of the gates **30** of the first and second transistors **24a**, **24b**. The gates **30a**, **30b** of the transistors **24a**, **24b** may not be directly adjacent one another. As such, the CB layer **36** forms a zig-zag shape to electrically connect both transistors **24a**, **24b**.

Specifically, as shown in FIG. 9, the device **20** includes a third transistor **24c** and a fourth transistor **24d**. The gate **30c** of the third transistor **24c** extends longitudinally as part of the first strip **31a** and the gate **30d** of the fourth transistor **24d** extends longitudinally as part of the second strip **31b**. A first gap **32a** separates the gate **30a** of the first transistor **24a** from the gate **30c** of the third transistor **24c**. A second gap **32b** separates the gate **30b** of the second transistor **24b** from the gate **30d** of the fourth transistor **24d**. The gaps **32a**, **32b** of the sixth embodiment are not aligned with one another.

Referring to FIGS. 2 and 10, the semiconductor device **20** of a seventh embodiment includes a first transistor **24a** and

a second transistor **24b**. A trench silicide layer **37** electrically connects the source **26a** or the drain **28a** of the first transistor **24a** to the source **26b** or the drain **28b** of the second transistor **24b**. Specifically, FIG. **10** shows the first transistor **24a** being an n-type FET and the second transistor **24b** being a p-type FET and that the raised drains **28a**, **28b** of the transistors **24a**, **24b** are electrically connected to one another via the trench silicide layer **37**.

The gate **30a** of the first transistor **24a** and the gate **30b** of the second transistor **24b** are formed from a common linear strip **31**. As such, the gates **30a**, **30b** extend linearly with respect to one another. The trench silicide layer **37** is disposed on one side of the gates **30a**, **30b**. That is, the trench silicide layer **37** does not cross over the gates **30a**, **30b** or the common linear strip **31** while still electrically connecting the drains **28a**, **28b** of the transistors **24a**, **24b**. Said another way, the trench silicide layer **37** need not cross a “poly boundary” formed by the linear strip **31**. This arrangement may be utilized to produce scan scan-D flip-flops. The resulting scan-D flip-flops have a reduced area when compared to prior art devices. Of course, the arrangement may be utilized in producing logic devices other than the scan-D flip-flops, as will be realized by those skilled in the art.

The semiconductor device **20** of the seventh embodiment may also include a single-sided contact (not shown) electrically connected to each gate **30a**, **30b** of the transistors **24a**, **24b**. By utilizing a single-sided contact, i.e., a contact that does not extend over the entire width of the gates **30a**, **30b**, the risk of dielectric breakdown between the trench silicide layer **37** and the gates **30a**, **30b** is reduced.

While at least one exemplary embodiment has been presented in the foregoing detailed description of the invention, it should be appreciated that a vast number of variations exist. It should also be appreciated that the exemplary embodiment or exemplary embodiments are only examples, and are not intended to limit the scope, applicability, or configuration of the invention in any way. Rather, the foregoing detailed description will provide those skilled in the art with a convenient road map for implementing an exemplary embodiment of the invention, it being understood that various changes may be made in the function and arrangement of elements described in an exemplary embodiment without departing from the scope of the invention as set forth in the appended claims and their legal equivalents.

What is claimed is:

**1.** A semiconductor device comprising:

a semiconductor substrate;

a first transistor and a second transistor disposed on the semiconductor substrate, wherein each transistor comprises a source, a drain, and a gate, wherein the gate of the first transistor extends longitudinally as part of a first linear strip and wherein the gate of the second transistor extends longitudinally as part of a second linear strip parallel to and spaced apart from the first linear strip;

a first CB layer forming a local interconnect layer electrically connected to the gate of the first transistor;

a second CB layer forming a local interconnect layer electrically connected to the gate of the second transistor; and

a CA layer forming a local interconnect layer extending longitudinally between a first end and a second end of the CA layer, wherein the CA layer is electrically connected to the first and second CB layers;

wherein the first CB layer is electrically connected adjacent the first end of the CA layer and the second CB layer is electrically connected adjacent the second end of the CA layer,

wherein the first CB layer, the second CB layer, and the CA layer are disposed between a first metal layer and the semiconductor substrate, the first metal layer being disposed above each source, each drain, and each gate of the first and second transistors, and

wherein the CA layer extends substantially parallel to the first and second linear strips and is substantially perpendicular to the first and second CB layers.

**2.** The semiconductor device according to claim **1** wherein the CA layer is disposed between the gate of the first transistor and the gate of the second transistor.

**3.** The semiconductor device according to claim **2** wherein the CA layer extends substantially parallel to the first linear strip and the second linear strip.

**4.** The semiconductor device according to claim **3** further comprising a third transistor having a gate extending longitudinally along the first linear strip and a fourth transistor having a gate extending longitudinally along the second linear strip.

**5.** The semiconductor device according to claim **4** wherein the gate of the first transistor and the gate of the third transistor are separated by a gap, and wherein the gate of the second transistor and the gate of the fourth transistor are separated by gap.

**6.** The semiconductor device according to claim **5** wherein the CA layer extends across each gap.

**7.** The semiconductor device according to claim **5** wherein the CA layer, the first CB layer, and the second CB layer each terminate at an uppermost surface, and wherein the uppermost surface of the CA layer, the uppermost surface of the first CB layer, and the uppermost surface of the second CB layer are at a same height above the semiconductor substrate.

**8.** The semiconductor device according to claim **7** wherein the first CB layer and the second CB layer each have a height of about 70 nm.

**9.** The semiconductor device according to claim **7** wherein the uppermost surface of the first CB layer and the uppermost surface of the second CB layer are no more than about 105 nm from the semiconductor substrate.

**10.** The semiconductor device according to claim **7** wherein the uppermost surface of the first CB layer, the uppermost surface of the second CB layer, and the uppermost surface of the CA layer are no more than about 105 nm from the semiconductor substrate.

**11.** The semiconductor device according to claim **1** wherein the CA layer extends substantially parallel to the first linear strip and the second linear strip.

**12.** The semiconductor device according to claim **11** further comprising a third transistor having a gate extending longitudinally along the first linear strip and a fourth transistor having a gate extending longitudinally along the second linear strip.

**13.** The semiconductor device according to claim **12** wherein the gate of the first transistor and the gate of the third transistor are separated by a gap, and wherein the gate of the second transistor and the gate of the fourth transistor are separated by gap.

**14.** The semiconductor device according to claim **1** wherein the CA layer extends across each gap.

**15.** The semiconductor device according to claim **1** wherein the CA layer, the first CB layer, and the second CB layer each terminate at an uppermost surface, and wherein

the uppermost surface of the CA layer, the uppermost surface of the first CB layer, and the uppermost surface of the second CB layer are at a same height above the semiconductor substrate.

**16.** The semiconductor device according to claim **15** 5 wherein the first CB layer and the second CB layer each have a height of about 70 nm.

**17.** The semiconductor device according to claim **1** wherein the first CB layer and the second CB layer each terminate at an uppermost surface, and wherein the upper- 10 most surface of the first CB layer and the uppermost surface of the second CB layer are no more than about 105 nm from the semiconductor substrate.

**18.** The semiconductor device according to claim **1** wherein the CA layer, the first CB layer, and the second CB 15 layer each terminate at an uppermost surface, and wherein the uppermost surface of the first CB layer, the uppermost surface of the second CB layer, and the uppermost surface of the CA layer are no more than about 105 nm from the semiconductor substrate. 20

**19.** The semiconductor device according to claim **1** wherein the first CB layer and the second CB layer each have a height of about 70 nm.

**20.** The semiconductor device according to claim **1** wherein: 25

the first CB layer directly contacts the gate of the first transistor; and

the second CB layer directly contacts the gate of the second transistor.

\* \* \* \* \*

30