

(19)



(11)

EP 1 151 545 B1

(12)

EUROPEAN PATENT SPECIFICATION

(45) Date of publication and mention of the grant of the patent:
25.04.2007 Bulletin 2007/17

(51) Int Cl.:
H04B 1/38^(2006.01) H04Q 7/32^(2006.01)
H04M 1/60^(2006.01)

(21) Application number: **00907156.4**

(86) International application number:
PCT/US2000/002899

(22) Date of filing: **04.02.2000**

(87) International publication number:
WO 2000/046932 (10.08.2000 Gazette 2000/32)

(54) **Communication protocol between a communication device and an external accessory**

Kommunikationsprotokoll zwischen einer Kommunikatinsinrichtung und einem externen Zusatzgerät

Protocole de communication entre un dispositif de communication et un accessoire externe

(84) Designated Contracting States:
AT BE CH CY DE DK ES FI FR GB GR IE IT LI LU MC NL PT SE

- **OPALSKY, Robert**
San Diego, CA 92122 (US)
- **PAN, George**
San Diego, CA 92131 (US)
- **CHINNASWAMI, Karthick**
San Diego, CA 92129 (US)
- **HUANG, Hanchi, David**
San Diego, CA 92126 (US)
- **DEN BESTE, Steven, C.**
San Diego, CA 92130 (US)

(30) Priority: **08.02.1999 US 248514**

(43) Date of publication of application:
07.11.2001 Bulletin 2001/45

(73) Proprietor: **QUALCOMM INCORPORATED**
San Diego, California 92121-1714 (US)

(74) Representative: **Dunlop, Hugh Christopher et al**
R G C Jenkins & Co.
26 Caxton Street
London SW1H 0RJ (GB)

- (72) Inventors:
- **CHANG, Chienchung**
San Diego, CA 92131 (US)
 - **LEE, Way-Shing**
San Diego, CA 92129 (US)

(56) References cited:
DE-A- 3 737 647 **US-A- 5 333 176**

EP 1 151 545 B1

Note: Within nine months from the publication of the mention of the grant of the European patent, any person may give notice to the European Patent Office of opposition to the European patent granted. Notice of opposition shall be filed in a written reasoned statement. It shall not be deemed to have been filed until the opposition fee has been paid. (Art. 99(1) European Patent Convention).

Description**BACKGROUND OF THE INVENTION**5 **I. Field of the Invention**

[0001] The present invention relates to digital communication protocols. More particularly, the present invention relates to a novel and improved communication protocol between a communication device such as a portable wireless telephone, and an external accessory such as a hands-free kit.

10

II. Description of the Related Art

[0002] In the art of digital audio processing, an audio band encoder/decoder (CODEC) is typically used to convert analog audio signals to encoded digital signals, and vice-versa. For example, the CODEC may receive the analog output of a microphone, and convert the microphone-generated analog audio signal into a Pulse Code Modulation (PCM) encoded digital audio signal for further digital signal processing in a digital signal processor (DSP). Additionally, the CODEC may receive a PCM-encoded digital audio signal from the DSP and convert it to an analog audio signal for use by an audio speaker. Of course, the CODEC may use additional digital encoding techniques as are known in the art, such as A-law, μ -law, or the like, or may merely use any other linear or non-linear encoding techniques.

15

[0003] A typical portable radiotelephone having an internal CODEC may be interfaced with one or more external accessories. For example, the portable radiotelephone user may desire to use his portable radiotelephone in his car while driving, and thus interface it with a hands-free speakerphone, a power booster, and /or a voice-operated dialer or voice recognition system. The hands-free speakerphone (or hands-free "kit") allows the user to make phone calls, via an external loudspeaker and microphone, without holding the radiotelephone, leaving the user's hands free to drive the car. The power booster couples radio frequency (RF) signal to and from the portable radiotelephone's own antenna, amplifying the RF signal for the higher power transmission and reception that is desirable when operating off of a car battery. A voice dialer responds to verbal commands from the user. For example, dialing from a set of preprogrammed telephone numbers according to the voice commands, dialing individual digits one at a time, or changing the operating mode of the radiotelephone. These accessories are often used at the same time as part of a car adapter kit.

20

[0004] US 5,333,176 describes an interface adapter for use with a cellular phone, to provide speakerphone functions, power the phone and recharge the battery.

25

[0005] A typical interface circuit between a portable radiotelephone and an external car kit is given in U.S. Patent No. 6,081,724, entitled "PORTABLE COMMUNICATION DEVICE AND ACCESSORY SYSTEM", filed January 31, 1996, assigned to the assignee of the present invention. The just-mentioned patent discloses a portable communications device and accessory system which enables both voice and control commands to be communicated between a portable communication device and external accessories over a single flexible digital interface. When the portable communication device is interfaced to external accessories, such as a power booster and hands-free kit, a microprocessor configures the serial communications bus to pass both the digital voice data and digital control commands to and from the external power booster and the hands-free kit. The external hands-free kit contains its own auxiliary CODEC for encoding analog voice signals and decoding the digital voice data. When the portable communication device is not interfaced with external accessories, the microprocessor configures the serial communication bus to pass the digital voice data to and from an internal CODEC for use with the portable device's own microphone and speaker.

30

[0006] However, there remains a need for a method and apparatus which implements a communication protocol between a portable wireless communication device such as a portable wireless telephone, and an external accessory such as a hands-free kit.

35

SUMMARY OF THE INVENTION

[0007] The present invention provides a novel and improved method for communicating both voice and control data, a portable communication device (such as a cellular phone), an external accessory (such as a hands-free kit) and a system as set forth in claims 1, 8, 15 and 23, respectively. Preferred embodiments are set forth in the dependent claims. The communication device may be a cellular telephone. The communication device of preferred embodiments comprises a microprocessor, a vocoder coupled to the microprocessor, read and write registers coupled to the microprocessor, and a multiplexer coupled to both the vocoder and the write register. The communication device communicates over a data bus with an external accessory. The external accessory preferably includes a digital signal processor, and a CODEC.

40

[0008] The apparatus of the present invention performs the method that is also referred to herein as a communication protocol. The method or protocol is for communicating both voice and control data between a communication device and an external accessory over a data bus. The method includes formatting a sequence of bits into a repeating sequence

45

of first time slots and second time slots, transmitting the voice data in the first time slot, and transmitting the control data in the second time slot. Notably, a first bit of each of the second time slots comprises a clock bit that alternates between a high value and a low value (e.g. a '1' or a '0') as between consecutive second time slots. This allows the receiving end (i.e., either the microprocessor in the communication device or the digital signal processor in the external accessory) to distinguish between consecutive bytes of data.

[0009] The sequence of second time slots comprises N+1 bytes. An initial byte of the N+1 bytes further comprises a synchronization bit sequence. A second of the N+1 bytes includes mode bits for defining a meaning of the remainder of the N+1 bytes (e.g., the data bits). Preferably, N is an odd integer so that all commands and control information is expressed as an even number of control bytes. Thus, when combined with the alternating clock bit scheme, this ensures that the initial byte always starts with the same clock bit.

[0010] The clock bit of a last byte of the N+1 bytes is of an opposite polarity than the clock bit of the initial byte of the N+1 bytes. This allows the receiving end to distinguish between consecutive commands that may be spread across two or more control bytes, interspersed with voice data. The method further includes setting a second bit of each of a respective third and higher-order of the N+1 bytes to an opposite polarity as the clock bit of each of the respective third and higher-order of the N+1 bytes. This prevents the receiving end from confusing a control byte that contains data from a control byte that contains the synchronization bit sequence.

BRIEF DESCRIPTION OF THE DRAWINGS

[0011] The features, objects, and advantages of the present invention will become more apparent from the detailed description set forth below when taken in conjunction with the drawings in which like reference characters identify correspondingly throughout and wherein:

FIG. 1 is functional block diagram of the apparatus of the present invention; and

FIG. 2 is a timing diagram of the exemplary embodiment of the present invention.

DETAILED DESCRIPTION OF THE PREFERRED EMBODIMENTS

[0012] FIG. 1 illustrates a functional block diagram of the apparatus of the present invention. Selected portions of a communication device **100**, such as a portable cellular telephone, PCS telephone, PDA or the like, is shown interfacing with an external accessory **102** over a data bus **101**. In the presently preferred embodiment, the data bus **101** is a full-duplex, synchronous serial bus with the exemplary data rate of 128 Kilo bits per second (Kbps). The data bus **101** carries Pulse-Code Modulated (PCM) data from the communication device **100** to the external accessory **102**, and from the external accessory **102** to the communication device **100**.

[0013] In the presently preferred embodiment, the functional block elements shown as being part of communication device **100** (i.e., microprocessor **106**, read register **104**, write register **112**, encoder **108**, decoder **110** and multiplexer (MUX) **114**) are all implemented in a single Application Specific Integrated Circuit (ASIC). Combining all of these functional blocks into a single ASIC has several advantages that are well known in the art, including reduced power consumption, reduced size, and decreased cost. However, it is contemplated by the present invention that some or all of these functional blocks may be implemented in physically separate devices, or grouped as desired. The actual implementation of these functional blocks is a matter of design choice based on the specific application, without departing from the present invention. Similarly, the functional block elements shown as being part of external accessory **102** may be implemented as a single ASIC, or in physically separate elements without departing from the present invention.

[0014] The presently preferred format of the data bus **101** includes a repeating sequence of two 8-bit, 8 KHz time slots. In other words, the 128 Kbps data stream may be viewed as two blocks of 8 bit samples, at 8 kilo samples per second. The first of the two 8-bit blocks is used for transmitting data samples. Preferably, the data samples are companded. In an exemplary voice application, the data samples are preferably companded as 8-bit μ -law or A-law. It is understood that other compression schemes may be used as are known in the art, or that the data may be merely linear (uncompanded). The second of the two 8-bit blocks is used to transmit control commands. These control commands may be for various modes of operation, including voice recognition, acoustic echo canceling, automatic gain control, and so forth.

[0015] As can be seen from FIG. 1, there are two data paths by which the microprocessor **106** may issue a control command to the external accessory **102** over the data bus **101**. The first path begins when microprocessor **106** generates an 8-bit control byte that is then passed to decoder **110**. Together, decoder **110** and encoder **108** form a voice encoder/decoder (vocoder) such as that described in U.S. Patent No. 5,414,796, entitled "Variable Rate Vocoder", issued May 9, 1995, assigned to the assignee of the present invention. The decoder **110** combines this 8-bit control byte from the microprocessor **106** with an 8-bit byte of companded voice data, and transmits the combined 8-bit bytes (a total of 16 bits) via MUX **114** over data bus **101** to external accessory **102**. When using this first path, the microprocessor **106**

configures MUX **114** to pass the output of decoder **110** over the data bus **101**. This first path is useful, for example, for the microprocessor **106** to send control data in the acoustic echo canceling mode when the decoder **110** is "on" (i.e., powered-up and actively processing voice samples).

[0016] The second path begins when the microprocessor **106** generates an 8-bit control byte that is then written to write register **112**. Write register is preferably 16 bits wide. If microprocessor **106** cannot read or write data as fast as 8KHz, it can simply write the 8-bit control byte into the 2nd byte of write register **112**. Write register **112** may be co-located in the same vocoder as decoder **110**. The 8-bit control byte is then transmitted through MUX **114** over data bus **101** based on the PCM interrupts on the data bus **101**. Note that in this second path, the decoder **110** need not be turned "on". This second data path is useful, for example, for the microprocessor **106** to send control data in the voice recognition mode when the decoder **110** is "off".

[0017] In either case, the companded data (e.g., voice data in the first 8-bit block) is provided to CODEC **120** by AUX DSP **116**. CODEC **120** decodes the voice data, and converts it to an analog audio-band voice signal for reproduction over speaker **118**. The control byte (e.g., control commands in the second 8-bit block) is provided to the appropriate entity in the external accessory **102**. For example, acoustic echo canceling commands are provided to the AUX DSP **116**.

[0018] In the reverse direction (i.e., from the external accessory **102** to the communication device **100**), the auxiliary digital signal processor (AUX DSP) **116** sends two 8-bit, 8KHz samples over the 128 Kbps data bus **101** to both encoder **108** and read register **104**. Again, the first of the two 8-bit blocks contains companded data (e.g., voice data sensed by microphone **122** and encoded by CODEC **120**), and the second 8-bit block contains control data.

[0019] Preferably, read register **104** is 16 bits wide. Both the first and second time slots (both PCM and control bytes from AUX DSP **116**) will update read register **104** at 8 KHz (i.e., update every time a new sample is received). If microprocessor **106** cannot read the PCM samples (the first slot) fast enough, the sample may be overwritten before microprocessor **106** can read it. A typical microprocessor **106** cannot read the read register **104** that fast. Thus, in the preferred embodiment, the control byte (the second slot) is repeated, for example, 10ms or 80 times, to allow enough time for microprocessor **106** to read it. It can then read the message in the control byte location of read register **104** even if it must ignore the PCM byte.

[0020] In the presently preferred embodiment, read register **104** is a microprocessor read register, which may be implemented as part of microprocessor **106**. However, in FIG. 1, it is shown as a separate functional block for clarity of disclosure. Microprocessor **106** may then read the contents of read register **104** at its convenience (i.e., not necessarily synchronously according to the data rate of data bus **101**). This reverse data path is used for the AUX DSP **116** to send information to the microprocessor **106** in, for example, either the acoustic echo canceling or voice recognition modes.

[0021] The present invention also provides a comprehensive communication protocol that allows full-duplex communications between the communication device **100** and the external accessory **102**. Any application running on the communication device **100** or external accessory **102** (e.g., software routines in microprocessor **106** or AUX DSP **116**) that requires the use of full duplex messaging over the data bus **101** may use the communication protocol of the present invention. For example, voice recognition applications or acoustic echo canceling applications may use this protocol.

[0022] The novel communication protocol of the present invention will now be described with reference to the exemplary embodiment of interfacing a portable wireless telephone to an external car kit adapter having voice recognition (VR), acoustic echo canceling (AEC), volume control and audio control. It is understood that the present invention is equally applicable to other embodiments having other applications. However, for simplicity and clarity of disclosure, the invention will be disclosed with reference to this exemplary embodiment.

[0023] The exemplary embodiment of the present invention provides for different classes of commands to be communicated from the microprocessor **106** to the external accessory **102**. These classes of commands include:

1. Generic Commands;
2. Commands from the Microprocessor **106** to the Voice Recognition Unit (VRU) in AUX DSP **116**;
3. Commands from the Microprocessor **106** to the AEC in AUX DSP **116**;
4. Volume Control Commands from the Microprocessor **106** to the AUX DSP **116**; and
5. Audio Control Commands from the Microprocessor **106** to the AUX DSP **116**.

[0024] The generic commands from the microprocessor **106** are accepted and acted upon by the AUX DSP **116** during any operational state of the external accessory **102**. These generic commands include:

1. Software Version Number (SVN) Inquiry;
2. Carkit Status Inquiry;
3. Acknowledgment Information;
4. Goto Idle Mode;
5. Goto Alternate Protocol;
6. Power Down Delay Settings; and

7. Extended Software Version Number Inquiry.

[0025] The microprocessor **106** uses the Software Version Number Inquiry command to inquire the software version number of the external accessory **102** after power up. The Software Version Number Inquiry command allows the microprocessor **106** to determine whether the software version number of the external accessory **102** is of a correct revision to support certain applications, such as voice recognition.

[0026] The CarKit Status Inquiry command allows the microprocessor **106** to poll the current status of the external accessory **102** whenever appropriate. This allows the microprocessor **106** to check the consistency of the operational modes between the microprocessor **106** and the AUX DSP **116**. For example, this command allows the microprocessor **106** to refresh its own memory about the privacy handset status, audio path setup, stereo mute/un-mute status, power status and volume status at its convenience. If the actual mode reported by the AUX DSP **116** is different than that expected by the microprocessor **106**, then the microprocessor **106** may order the external accessory **102** to change its operational status, or the microprocessor **106** may change its own internal status to regain consistency with the external accessory **102**.

[0027] After a group of information is received by the microprocessor **106** from the AUX DSP **116**, the microprocessor **106** will send an Acknowledgement Information command to the AUX DSP **116**. The AUX DSP **116** does not send the next group of information until this Acknowledgement Information command is received from the microprocessor **106**. Thus, the Acknowledgement Information command provides for reliable data transmission over the data bus **101**.

[0028] The Goto Idle mode command instructs the AUX DSP **116** to enter Idle mode (i.e., to leave the active application). This command allows the microprocessor **106** to switch the AUX DSP **116** from any operational mode into the Idle state. There are two conditions that can lead to the AUX DSP **116** entering the Idle state. First, if the microprocessor **106** sends a Goto Idle mode command, and second if the AUX DSP **116** does not receive the clock signal used by the present invention (discussed more fully below) for a predetermined period. In the exemplary embodiment, this predetermined period is 8.75 ms.

[0029] The Goto Alternate Protocol mode command instructs the AUX DSP **116** to use an alternate communication protocol, rather than the communication protocol of the present invention as disclosed herein. This alternate communication protocol may be a previous generation protocol, or a protocol that supports additional or separate features and applications.

[0030] The Power Down Delay Setting command is used by the phone to delay the power down action of the external accessory **102** when it is connected to an external power source (such as a car ignition) and the external power source is turned off.

[0031] The Extended Software Version Number Inquiry is used by the microprocessor **106** to inquire the extended version stamp from the AUX DSP **116**. In this exemplary embodiment, the extended version stamp consists of eight ASCII characters. For example, these eight ASCII characters may be used to refer to the filename utilized by the AUX DSP **116** software build.

[0032] In the exemplary embodiment having voice recognition (VR) capability in the AUX DSP **116**, the microprocessor **106** also sends commands to the voice recognition unit (VRU) in AUX DSP **116**. A more detailed discussion of the VRU is given in U.S. Patent No. 6,449,496 entitled "VOICE RECOGNITION USER INTERFACE FOR TELEPHONE HANDSET", assigned to the assignee of the present invention. In this just-mentioned patent, the VR templates and corresponding phone numbers are saved in the AUX DSP **116**. Thus, an exemplary set of commands that the microprocessor **106** would send to the AUX DSP **116** includes the following:

1. VR Initialization
2. VR Recognition
3. YES (Yes Key)
4. NO (NO Key)
5. CANCEL/CLEAR (CANCEL or CLEAR Key)
6. NEXT/MORE (NEXT or MORE Key)
7. PREVIOUS (PREVIOUS Key)
8. Train Basic Set
9. Train Digit Set
10. Force Program (PROGRAM Key)
11. Force Retrain (RETRAIN Key)
12. Force Train (TRAIN Key)
13. VR Memory Reset
14. Clear Phonebook
15. VR Status Inquiry
16. Incoming Call

- 17. Incoming Roam Call
- 18. Digits, 0-9, # (Pound Key), * (Star Key), Pause
- 19. End of Digit String

5 **[0033]** Any input from the user interface (not shown), such as a keypad, is translated by the microprocessor **106** and transmitted to the VRU in AUX DSP **116** to maintain synchronization between the communication device **100** and the external accessory **102**. This ensures that the VRU will act appropriately, such as playing the correct voice prompts to solicit audio input from the user.

10 **[0034]** The VR Initialization command is used to drive the AUX DSP **116** from Idle mode (where no VR tasks are being performed) to VR Standby Mode. The VR Recognition command will normally follow the VR Initialization command and is used to drive the AUX DSP **116** from VR Standby mode to VR Recognition mode where it actively performs voice recognition tasks. In the preferred embodiment, the YES, NO, CANCEL/CLEAR, NEXT/MORE, PREVIOUS, Digits 0-9, pound, star, and pause commands are sent in response to the user pressing the associated keys on the keypad (not shown). This provides a means for the user to respond to prompts and menu selections from the VRU.

15 **[0035]** The Train Basic Set, Train Digit Set, Force Program, Force Retrain, and Force Train commands are used in "training" the VRU to recognize the individual speaker's voice, including recognizing commands, digits and nametags. The VR Memory Reset command is used to reset the nametags, the associated phone numbers, and the VR templates. In other words, this command would cause AUX DSP **116** to erase all the memories programmed. The Clear Phonebook command is used to reset all the entries of the user's own personal phonebook directory, including both nametags and the associated phone numbers. The Clear Phonebook command, unlike the VR Memory Reset command, does not erase the VR templates associated with control words.

20 **[0036]** The VR Status Inquiry command is used by microprocessor **106** to determine the present status of the VRU (e.g., Idle, Standby, or Voice Recognition modes). The Incoming Call and Incoming Roam Call commands are used by microprocessor **106** to inform AUX DSP **116** that there is an incoming call while in the VR mode. In response, the VRU will play an appropriate voice prompt to solicit input from the user. The End of Digit String command is used by the microprocessor **106** to convey the end of a string of digits (such as a phone number) to the AUX DSP **116**.

25 **[0037]** In the exemplary embodiment, the microprocessor **106** also sends commands to the acoustic echo canceller (AEC) in AUX DSP **116**. If the communication device **100** is a dual-mode analog/CDMA wireless telephone, these AEC control commands include:

- 30
- 1. FM AEC On;
 - 2. CDMA AEC On (Noise Suppressor On); and
 - 3. CDMA AEC On (Noise Suppressor Off).

35 **[0038]** The microprocessor **106** may order the AUX DSP **116** to switch to VR mode from AEC mode by using the VR Initialization command explained above.

[0039] In the exemplary embodiment, the microprocessor **106** also sends commands for PCM volume control to AUX DSP **116**. These commands are used to adjust the output speech volume digitally within AUX DSP **116**. The microprocessor **106** sends a PCM Volume Level Index to the AUX DSP **116**.

40 **[0040]** In the exemplary embodiment, the microprocessor **106** also sends Audio Control commands to the AUX DSP **116**. These commands are used, for example, to mute and un-mute a car stereo that is located in the same vehicle so that the user's voice may be heard by the VRU. Another example is a Privacy Handset Operation command that will mute the microphone **122** so that the user may speak without the called party hearing the user's voice.

45 **[0041]** The exemplary embodiment of the present invention also provides for different classes of information to be communicated from the AUX DSP **116** to the microprocessor **106**. These classes of information include:

- 50
- 1. Software Version Number (SVN);
 - 2. VR Mode;
 - 3. Generic Mode; and
 - 4. Extended Software Version Number.

[0042] The SVN is used as a response to the Software Version Inquiry command from microprocessor **106** described above. In the exemplary embodiment, the range of the SVN is from 0 to 1023 in decimal. The AUX DSP **116** may report the SVN, together with other information such as Privacy Handset Status and VR Status, to the microprocessor **106** spontaneously after the PCM clock signal (described more fully below) is first detected by AUX DSP **116**.

[0043] Based on the VR mode commands outlined above from the microprocessor **106** to the AUX DSP **116**, it can be readily seen that the VRU in AUX DSP **116** must provide certain information back to microprocessor **106**. For example, the AUX DSP **116** may transmit the VSN and VWN (Vocabulary Word Number) to send a sequence of digits ended with

the End of Digit String command to deliver digits for voice dialing. It may also report the VR status and solicit a display (not shown) in communication device **100** to provide appropriate visual user feedback (e.g., menus and messages) to guide the user while operating in VR mode. Alternately, the AUX DSP **116** may use the VR Digits and End of Digit String commands to reduce the traffic and accelerate the voice dialing process as compared to the VSN and VWN messages.

However, this is limited to digits only, not control bytes.

[0044] Generic Mode information includes the following:

1. Privacy Handset Offhook/Onhook;
2. Current Audio Path;
3. PCM Volume Control;
4. Power Status;
5. Stereo Mute/Un-mute; and
6. Carkit Modes.

[0045] Each of these groups of information relays information about the various operational parameters and states of the external accessory **102**. This information may be provided from AUX DSP **116** to microprocessor **106** upon specific inquiry by microprocessor **106**. Additionally, the AUX DSP **116** may spontaneously report some or all of the above information upon a change in status. For example, when the privacy handset position changes, when the power status changes, when the data detection status changes, or when the VRU changes its operational state.

[0046] As mentioned previously, the Extended SVN information is stored in AUX DSP **116** as a version stamp, which consists of eight ASCII characters. For example, the version stamp may be used to encode the filename of the DSP software source file. The Extended SVN information is reported only when the microprocessor **106** transmits the Extended SVN Inquiry command described above.

[0047] Turning now to FIGS. 2A and 2B, a timing diagram of the signaling format used on data bus **101** is illustrated. FIG. 2A illustrates a timing diagram for the first time slot of the two 8-bit time slots, and FIG. 2B illustrates a timing diagram for the second time slot of the two 8-bit time slots. Note that for clarity and continuity of explanation, there is some overlap between FIG. 2A and FIG. 2B. As previously stated, the first time slot shown in FIG. 2A is used for carrying μ -law encoded data such as voice data. The second time slot shown in FIG. 2B is used for carrying control data and information data, such as the control commands and information groups described above.

[0048] As can be seen in both FIGS. 2A and 2B, the PCM clock is preferably a 128 KHz clock signal. A separate signal, PCM SYNC, is preferably an 8 KHz synchronization signal. In FIG. 2A, the PCM SYNC signal is low for the first time slot. In FIG. 2B, the PCM SYNC signal is high for the second time slot. The signals PCM DATA OUT and PCM DATA IN of FIGS. 2A and 2B are used to carry the actual information data across the data bus **101**. In both FIGS. 2A and 2B, the PCM DATA OUT and PCM DATA IN signals are illustrated as being in either the high or low state for each data bit, according to the value of the data bits they are carrying.

[0049] In FIG. 2A, PCM DATA OUT is illustrated as being comprised of the data bits D7/, D6/, D5/, D4/, D3/, D2/, D1/, and D0/. Similarly, in FIG. 2A, PCM DATA IN is illustrated as being comprised of the data bits D7, D6, D5, D4, D3, D2, D1, and D0. These data bits represent an eight-bit first time slot which carries μ -law encoded voice data between the communication device **100** and the external accessory **102**. These bits are clocked serially across the data bus **101** by the PCM CLOCK signal. The signal PCM DATA OUT flows in the direction from the communication device **100** to the external accessory **102**. The signal PCM DATA IN flows in the reverse direction from the external accessory **102** to the communication device **100**. Both the PCM CLOCK signal and the PCM SYNC signal flow in the direction from the communication device **100** to the external accessory **102**.

[0050] At the end of the first 8-bit time slot, the second 8-bit time slot begins. The second 8-bit time slot is shown in FIG. 2B. In FIG. 2B, PCM DATA OUT is illustrated as being comprised of a single clock bit, Clock/, and seven data bits, Data6/, Data5/, Data4/, Data3/, Data2/, Data1/, and Data0/. These clock and data bits represent the second eight-bit time slot that carries command and control data, such as that described above, from microprocessor **106** to AUX DSP **116**. The Clock/ bit is used to latch and combine data across time slots. The Data6/-Data0/ bits are 7 bits per sample at each time slot used to accumulate the control information from the microprocessor **106**. Similarly, the signal PCM DATA IN is shown as being comprised of a single clock bit, Clock, and seven data bits, Data6, Data5, Data4, Data3, Data2, Data1, and Data0. These clock and data bits represent the second eight-bit time slot that carries information and inquiry response data, such as that described above, from AUX DSP **116** to microprocessor **106**.

[0051] In the direction of the microprocessor **106** to the AUX DSP **116**, the format of the information carried by the second eight-bit time slot is given below in TABLE I for an N+1 byte command.

EP 1 151 545 B1

TABLE I: Bit Configuration for N+1 Byte Command

Byte #	8 Bits of Second Time Slot								Configuration Description
	Clock	Data6	Data5	Data4	Data3	Data2	Data1	Data0	
0	0	S6	S5	S4	S3	S2	S1	S0	Synchronization Bits
1	1	M2	M1	M0	D3	D2	D1	D0	Mode Bits and Data Bits.
2	0	0	D9	D8	D7	D6	D5	D4	
...	
N	1	0	D _{6N-3}	D _{6N-4}	D _{6N-5}	D _{6N-6}	D _{6N-7}	D _{6N-8}	Terminate with a data byte with Clock=1

[0052] As can be seen from TABLE 1, the initial byte (Byte 0) of any command from the microprocessor **106** begins with the Clock bit being set to 0 (low). Alternately, it could be set to high in a different embodiment. However, as can be seen from TABLE I, the Clock bit of each byte alternates to allow the AUX DSP **116** to keep track of commands across the time slots. The next seven bits of the initial byte of any command are synchronization bits: S6, S5, S4, S3, S2, S1, and S0. Together, these synchronization bits form a synchronization header. In the exemplary embodiment, the synchronization header for a command packet is the bit pattern '1111110' (0x7e hexadecimal). Note that the synchronization bits of TABLE I are to be distinguished from the PCM SYNC signal of FIGS. 2A and 2B, which is a separate signal.

[0053] The next byte of any command (Byte 1) begins with the opposite Clock bit as was used to start the previous byte. Here, because the previous byte began with the Clock bit '0', Byte 1 begins with Clock bit '1'. The next three bits of the byte are mode bits M2, M1, and M0. These mode bits are used to identify the class or type of command being transmitted by microprocessor **106**. In the exemplary embodiment, the mode bits configuration is given in TABLE II below.

TABLE II: Mode Bits Configuration

M2	M1	M0	Description
0	0	0	Generic and AEC Commands
0	0	1	Audio Control
0	1	0	PCM Volume Control
0	1	1	VR Digit Keys
1	0	0	VR Commands
x	x	x	[M2-M0]=0x5-0x7, Reserved.

[0054] Referring again to TABLE I, the remaining bits of Byte 1, D3, D2, D1, and D0 are data bits used to convey the actual command, whose definition is dependent upon the value of the previous mode bits. In other words, for each combination of mode bits [M2-M0], the data bits [D3-D0] represent a different command. Each of the commands described above are represented by a different combination of mode bits and data bits. Commands that are more than two-bytes in length are also provided by the format outlined in TABLE I, by adding on an additional number of data bytes. For each of these additional data bytes, it should be noted that the value of the Data6 bit is set to '0' to prevent the combination of mode bits and data bits from replicating the reserved sync bit pattern '1111110' (0x7e hex).

[0055] It also should be noted that a microprocessor 106 command always consists of an even number of bytes (i.e., N+1 is an even number in TABLE I), and always starts with the sync byte 0x7e (hex). The even total number of bytes per command ensures that any command would end with a Clock bit set to '1'. This prevents confusion as to whether the last byte of any command was the start of a new block of command bytes (which would begin with Clock bit '0').

[0056] An exemplary configuration of data bits for the various exemplary modes are shown in the TABLES III-VIII below.

TABLE III: Data Bits Definition of Mode 0 Commands

D3	D2	D1	D0	Description
0	0	0	0	SVN Inquiry
0	0	0	1	ACK_0
0	0	1	0	ACK_1

EP 1 151 545 B1

(continued)

D3	D2	D1	D0	Description
0	0	1	1	Carkit Status Inquiry
0	1	0	0	FM AEC On
0	1	0	1	CDMA AEC On (Noise Suppressor On)
0	1	1	0	CDMA AEC On (Noise Suppressor Off)
0	1	1	1	Goto Idle
1	0	0	0	Goto Alternate Protocol
1	0	0	1	Power Down Delay 0
1	0	1	0	Power Down Delay 1
1	1	0	0	Extended SVN Inquiry
1	x	x	x	[D3-D0]=0xD-0xF, Reserved

TABLE IV: Data Bits Definition of Mode 1 Commands

Bit	Description
D0	Stereo Un-mute(0)/Mute(1),
D1	Privacy Handset(0)/Handsfree(1)
D2, D3	Reserved (Default 0)

TABLE V: Data Bits Definition of Mode 2 Commands

D3	D2	D1	D0	Description
0	x	x	x	[D2-D0]=PCM Volume Level Index(0x0-0x7) 0x7:Audio mute 0x0-0x6: indices used by the AUX DSP for appropriate amplification of PCM volume.
1	x	x	x	Reserved

TABLE VI: Data Bits Definition of Mode 3 Commands

D3	D2	D1	D0	Description
0	0	0	0	'0'
0	0	0	1	'1'
0	0	1	0	'2'
0	0	1	1	'3'
0	1	0	0	'4'
0	1	0	1	'5'
0	1	1	0	'6'
0	1	1	1	'7'
1	0	0	0	'8'
1	0	0	1	'9'
1	0	1	0	'#' (Pound)

EP 1 151 545 B1

(continued)

D3	D2	D1	D0	Description
1	0	1	1	'*' (Star)
1	1	0	0	'Pause'
1	1	0	1	End of Digit String
x	x	x	x	[D3-D0]=0xE-0xF, Reserved

TABLE VII: Data Bits Definition of Mode 4 Commands

D3	D2	D1	D0	Description
0	0	0	0	VR Initialization
0	0	0	1	VR Recognition
0	0	1	0	YES
0	0	1	1	NO
0	1	0	0	CANCEL/CLEAR
0	1	0	1	NEXT/MORE
0	1	1	0	PREVIOUS
0	1	1	1	Train Basic Set
1	0	0	0	Train Digit Set
1	0	0	1	Force Program
1	0	1	0	Force Retrain
1	0	1	1	Force Train
1	1	0	0	VR Memory Reset
1	1	0	1	Clear Phonebook
1	1	1	0	VR Status Inquiry
x	x	x	x	[D3-D0]=0xF, Reserved

TABLE VIII: Data Bits Definition of Mode 5 Commands

D3	D2	D1	D0	Description
0	0	0	0	Incoming Call
0	0	0	1	Incoming Roam Call
x	x	x	x	[D3-D0]=0x2-0xF, Reserved

[0057] It should be again noted that the total number of command bytes for each microprocessor **106** command, including one sync byte, is an even number. This ensures that the Clock bit of the Sync byte is always '0'. It thereby facilitates the integration of command bytes in the AUX DSP **116**. Additionally, there are two types of Acknowledgement commands from the microprocessor **106** to the AUX DSP **116**. They are listed in TABLE III above as ACK_0 and ACK_1. ACK_0 is used by the microprocessor **106** to acknowledge the bytes from the AUX DSP **116** that have the Clock bit '0', while ACK_1 is used by the microprocessor **106** to acknowledge the bytes from the AUX DSP **116** that have the Clock bit '1'. The microprocessor **106** repeats the ACK command periodically. This prevents potential deadlocks of the communication between the microprocessor **106** and the AUX DSP **116** over the data bus **101**.

[0058] AUX DSP **116** decodes the above commands and information data from microprocessor **106**, and acts on them appropriately. In order for AUX DSP **116** to properly decode these commands and information, it must determine when their format is valid by counting the number of bytes received. According to the above-described protocol, it is clear that

EP 1 151 545 B1

an incoming group of information (e.g., a command) is only valid when 8 consecutive bits are received. If less than 8 consecutive bits are received, they will be discarded and the AUX DSP 116 will begin counting again. Additionally, if a valid information group (i.e., all 8 consecutive bits) is received, but the command is not within the above-protocol, it will be discarded.

[0059] The present invention also provides a protocol for transmission of information from AUX DSP 116 to microprocessor 106. It is very similar to the protocol for transmissions from microprocessor 106 to AUX DSP 116 as described above. However, there are certain differences that will be noted.

[0060] TABLE IX below shows the bit configuration for a message of N+1 bytes from AUX DSP 116 to microprocessor 106. Any of the messages outlined above from AUX DSP 116 to microprocessor 106 may be transmitted using the bit configuration of TABLE IX.

TABLE IX: Bit Configuration of (N+1) Bytes Message

Byte #	8 Bits of Second Time Slot								Configuration Description
	Clock	Data6	Data5	Data4	Data3	Data2	Data1	Data0	
0	1	S6	S5	S4	S3	S2	S1	S0	Synchronization Bits
1	0	M2	M1	M0	D3	D2	D1	D0	Mode Bits and Data Bits.
2	1	0	D9	D8	D7	D6	D5	D4	
...	
N	0	1	D _{6N-3}	D _{6N-4}	D _{6N-5}	D _{6N-6}	D _{6N-7}	D _{6N-8}	Terminate with a data byte with Clock=0.

[0061] As can be seen from a comparison of TABLE IX to TABLE I above, one difference is that the first byte (Byte 0) of any message from the AUX DSP 116 to the microprocessor 106 begins with the Clock bit '1', rather than the Clock bit '0'. Additionally, the last byte (Byte N, where N is odd) of any message from the AUX DSP 116 to the microprocessor 106 will begin with a Clock bit '0', rather than the Clock bit '1'. As noted above, it is this alternating of Clock bits, and the last byte of the message using the opposite clock bit as used in the first byte of the message that allows microprocessor 106 to track received messages accurately and accumulate multi-byte messages over several bytes.

[0062] In the exemplary embodiment, the synchronization bits [S6-S1] from AUX DSP 116 to microprocessor 106 are different than those shown above for the direction from the microprocessor 106 to the AUX DSP 116. In the exemplary embodiment, the sync bits [S6-S1] from AUX DSP 116 are '1001100'. As previously noted, these sync bits [S6-S1] serve to separate two separate multi-byte messages from AUX DSP 116 to microprocessor 106.

[0063] The mode bits [M2-M0] of TABLE IX serve the same purpose as those of TABLE 1 above. TABLE X below shows the mode bits configuration for messages from the AUX DSP 116 to the microprocessor 106. It should be noted that the data bits after the first information group are set so that Data6 is equal to Clock/. This prevents the sequence of Mode Bits plus Data Bits from mimicking the reserved sync bit pattern, 0xCC (hex). It should also be noted that Mode 0 (e.g., M2, M1, M0 all set to zero) is disallowed so that information group 1 can not be the 0x00 pattern. It is undesirable to have a 16 bit frame where the μ -law data is 0x00 in the first 8-bit time slot, and the message data is also 0x00 in the second 8-bit time slot. This all-zero sequence may be misinterpreted as the external accessory 102 being disconnected from the data bus 101.

TABLE X: Mode Bits Configuration

M2	M1	M0	Description
0	0	0	Illegal
0	0	1	Generic (HFK Status)
0	1	0	VR Mode, VSN+VWN
0	1	1	SVN
1	0	0	VR Mode, Digits
1	0	1	VR Mode, State
1	1	0	Extended SVN
x	x	x	[M2-M0]=0x7, Reserved.

EP 1 151 545 B1

[0064] For each of the different modes, the data bits have different meanings, as outlined in the following tables. For Mode 1, [M2-M0]=0x1, the data bits are used to convey Generic Mode and status information. The data format of the message in Generic Mode is a 4-byte message as shown below in TABLE XI. The Mode 1 command for status may be sent spontaneously by AUX_DSP 116 upon a change of status that should be displayed to the user on a display (not shown). For example, an ignition status change, a privacy handset status change, or a VRU status change.

TABLE XI: Data Bits Definition at Mode 1 Messages

Bits	Description
D0	IGN_5V_OFF(0)/IGN_5V_ON(1)
D1	Privacy Offhook(0)/Onhook(1)
D2	Handset(0)/Handsfree(1)
D3	Stereo_Unmute(0)/Stereo_Mute(1)
D6-D4	PCM Volume Index
[D10-D7]	0x0: IDLE 0x1: AEC_FM 0x2: AEC_CDMA_NS_ON 0x3: AEC_CDMA_NS_OFF 0x4 VR_RECOG 0x5 VR_PROGRAM 0x6-0xF: Reserved
D14-D11	Reserved (Default 0x0)
D15	Data Detection Off(0)/On(1)

[0065] For Mode 2, the messages are VR Mode messages using vocabulary set number (VSN) and vocabulary word number (VWN). The vocabulary words are partitioned into vocabulary sets. Each vocabulary word is denoted with a VSN and a VWN. The mapping of vocabulary words to VSN and VWN is shown in TABLE XII. It requires four information groups (bytes) to complete the data packets for each VSN and VWN combination. The format of data bits for this four byte message is given in TABLE XII below where [D4-D0] is the VSN (0x0-0x1F), and [D15-D5] is the VWN (0x0-0x7FF).

EP 1 151 545 B1

TABLE XII: Mapping of Vocabulary Words to VSN+VWN

5
10
15
20
25
30
35
40
45
50
55

VSN	Vocabulary Word
0 (Control Word)	VWN:
	0x0 Call
	0x1 Redial
	0x2 Program
	0x3 Book
	0x4 Add
	0x5 Delete
	0x6 Yes
	0x7 No
	0x8 Exit
	0x9 Number
	0xA Clear
	0xB End
	0xC Verify
	0xD Cancel
	0xE Directory
0xF Dial	
0x10 Talk	
0x11-0x7FF, Reserved	
1 (Digit)	VWN:
	0x0 One
	0x1 Two
	0x2 Three
	0x3 Four
	0x4 Five
	0x5 Six
	0x6 Seven
	0x7 Eight
	0x8 Nine
	0x9 Zero
	0xA Oh
	0xB Star
	0xC Pound
0xD-0x7FF, Reserved	
2 (Nametag)	Nametag Set (up to 40)
3-15	Reserved

[0066] Mode 3 messages are SVN messages. The data format for Mode 3 messages is shown below in TABLE XIII. Mode 3 messages are 4-byte messages. The Mode 3 message may be sent spontaneously by AUX DSP 116 when the

EP 1 151 545 B1

PCM CLOCK signal (FIG. 2) is first detected by AUX DSP 116, indicating that external accessory 102 has just been connected to the communication device 100.

TABLE XIII: Data Bits Definition for Mode 3 Messages

Bits	Description
D0	Without VR(0)/With VR(1)
D1	Privacy Handset Offhook(0)/Onhook(1)
D5-D2	Reserved (Default 0x0)
D15-D6	SVN (0x0-0x3FF)

[0067] Mode 4 messages are VR Digits messages. The data format for Mode 4 messages is shown below in TABLE XIV. Mode 4 messages are 2-byte messages.

TABLE XIV: Data Bits Definition for Mode 4 Messages

D3	D2	D1	D0	Description
0	0	0	0	'0'
0	0	0	1	'1'
0	0	1	0	'2'
0	0	1	1	'3'
0	1	0	0	'4'
0	1	0	1	'5'
0	1	1	0	'6'
0	1	1	1	'7'
1	0	0	0	'8'
1	0	0	1	'9'
1	0	1	0	'#' (Pound)
1	0	1	1	'*' (Star)
1	1	0	0	'Pause'
1	1	0	1	End of Digit String
x	x	x	x	[D3-D0]=0xE-0xF, Reserved

[0068] Mode 5 messages are VR Status messages. The data format of the Mode 5 messages is shown below in TABLE XV. Mode 5 messages are 4-byte messages. It should be noted that in TABLE XV below, there are two Groups: Group 0 and Group 1. When a VR Status Inquiry is received by AUX DSP 116, the Group 0 message will be reported to reflect the current VR state. Group 1 messages are reported spontaneously by AUX DSP 116 whenever appropriate.

EP 1 151 545 B1

TABLE XV: Data Bits Definition for Mode 5 Messages

5
10
15
20
25

Bits	Description
[D3-D0]=0x0 (Group 0)	[D15-D4]: 0x0: VR_RECOG_MODE 0x1: VR_PROG_MODE 0x2: VR_INIT_TRAIN_MODE 0x3 VR_CALL_MODE 0x4 VR_NUMBER_MODE 0x5 VR_REDIAL_MODE 0x6 VR_BOOK_MODE 0x7 VR_ADD_MODE 0x8: VR_DELETE_MODE 0x9 VR_TRAIN_MODE 0xA VR_RETRAIN MODE 0xB VR_STANDBY_MODE 0xC-0xFFF: Reserved
[D3-D0]=0x1 (Group 1)	0x0: VR_NOT_RECOGNIZED 0x1: VR_RECOGNIZED 0x2: VR_PHONEBOOK_FULL 0x3: VR_PHONEBOOK_EMPTY 0x4: VR_N_BEST 0x5: VR_DIGIT_NOT_TRAINED 0x6-0xFFF: Reserved

30

[0069] Mode 6 messages are Extended SVN messages. The data format of Mode 6 messages is given below in TABLE XVI. The Extended SVN message is a 10-byte message. 52 data bits are used to represent the Extended SVN data, which, as previously noted, consists of 8 ASCII characters. The offset of each character's ASCII code from the '0' character (0x30 hex) is encoded in the last 8 bytes of the message.

TABLE XVI: Data Bits Definition for Mode 6 Messages

35
40
45

Bits	Description
[D3-D0]=0x0 (Group 0)	[D9-D4]: ASCII_CODE_0-0x30 [D15-D10]: ASCII_CODE_1-0x30 [D21-D16]: ASCII_CODE_2-0x30 [D27-D22]: ASCII_CODE_3-0x30 [D33-D28]: ASCII_CODE_4-0x30 [D39-D34]: ASCII_CODE_5-0x30 [D45-D40]: ASCII_CODE_6-0x30 [D51-D46]: ASCII_CODE_7-0x30-
[D3-D0]=0x1-0x7	Reserved

50

[0070] As with the commands from microprocessor **106** to AUX DSP **116**, all messages from the AUX DSP **116** to the microprocessor **106** consist of an even number of bytes. However, the messages from the AUX DSP **116** to the microprocessor **106** start with the byte 0xCC with Clock bit set to '1', and end with the last byte having a Clock bit set to '0'. Thus, each of the messages is at least a 2-byte message.

55

[0071] A message byte sent from the AUX DSP **116** to the microprocessor **106** is acknowledged by the microprocessor **106**. The AUX DSP **116** does not send the next message byte unless a corresponding Acknowledge command is received. As a result, the contents of read register **104** (FIG. 1) stay unchanged until microprocessor **106** reads the contents, and sends out the Acknowledge command. This ensures that the microprocessor **106** will not miss the contents of the read register **104**.

[0072] Any message byte from the AUX DSP **116** to the microprocessor **116** will be not all zeros (0x00). The reason

is that this byte, if combined with a 0x00 μ -law data byte could lead to a false indication that the external accessory **102** is not connected to data bus **101**.

[0073] Thus, the present invention provides a communication protocol between a communication device and an external accessory that operates reliably in full-duplex. The previous description of the preferred embodiments is provided to enable any person skilled in the art to make or use the present invention. The various modifications to these embodiments will be readily apparent to those skilled in the art, and the generic principles defined herein may be applied to other embodiments without the use of the inventive faculty. Thus, the present invention is not intended to be limited to the embodiments shown herein but is to be accorded the widest scope consistent as defined by the claims.

Claims

1. A method of communicating both voice and control data between a portable communication device (100) and an external accessory (102) over a data bus (101), the method comprising the steps of :

formatting (106,116) a sequence of bits into a repeating sequence of first time slots and second time slots;
 providing (106,116) a first bit of each of said second time slots with a clock bit that alternates between a high value and a low value as between consecutive second time slots;
 transmitting (106,116) said voice data in said first time slot; and
 transmitting (106,116) said control data in said second time slot.

2. The method of claim 1, wherein said sequence of second time slots comprises N+1 bytes, an initial byte of said N+1 bytes further comprising a synchronization bit sequence.

3. The method of claim 2, wherein a second of said N+1 bytes comprises mode bits for defining a meaning of the remainder of said N+1 bytes.

4. The method of claim 3, wherein N is an odd integer.

5. The method of claim 4, wherein said clock bit of a last byte of said N+1 bytes is of an opposite polarity than said clock bit of said initial byte of said N+1 bytes.

6. The method of claim 5, further comprising the step of setting a second bit of each of a respective third and higher-order of said N+1 bytes to an opposite polarity as said clock bit of each of said respective third and higher-order of said N+1 bytes.

7. The method of claim 1, further comprising the step of repeatedly transmitting a same control data byte for a predetermined number of occurrences of said second time slot.

8. A portable communication device (100) for communicating both voice and control data to an external accessory (102) via a data bus (101), the device (100) comprising :

a microprocessor (106) adapted to:

format a sequence of bits into a repeating sequence of first time slots and second time slots,
 provide a first bit of each of said second time slots with a clock bit that alternates between a high value and a low value as between consecutive second time slots, and
 transmit said voice data in said first time slot and said control data in said second time slot.

9. The device (100) of claim 8, wherein said sequence of second time slots is adapted to comprise N+1 bytes, an initial byte of said N+1 bytes being adapted to comprise a synchronization bit sequence.

10. The device (100) of claim 9, wherein a second of said N+1 bytes is adapted to comprise mode bits for defining a meaning of the remainder of said N+1 bytes.

11. The device (100) of claim 10, wherein N is adapted to be an odd integer.

12. The device (100) of claim 11, wherein said clock bit of a last byte of said N+1 bytes is adapted to be of an opposite

polarity than said clock bit of said initial byte of said N+1 bytes.

5 13. The device (100) of claim 12, further comprising means for setting a second bit of each of a respective third and higher-order of said N+1 bytes to an opposite polarity as said clock bit of each of said respective third and higher order of said N+1 bytes.

14. The device (100) of any one of claims 8 to 13, further comprising:

10 a voice encoder (108) coupled to said microprocessor (106);
a voice decoder (110) coupled to said microprocessor (106);
a read register (104) coupled to said encoder (108) and said microprocessor (106);
a write register (112) coupled to said microprocessor (106); and
a multiplexer (114) coupled to said decoder (110) and said write register (112).

15 15. An external accessory (102) for communicating both voice and control data to a portable communication device (100) via a data bus (101), the external accessory (102) comprising :

a digital signal processor (116) adapted to:

20 format a sequence of bits into a repeating sequence of first time slots and second time slots,
provide a first bit of each of said second time slots with a clock bit that alternates between a high value and
a low value as between consecutive second time slots, and
transmit said voice data in said first time slot and said control data in said second time slot

25 16. The external accessory (102) of claim 15, wherein said sequence of second time slots is adapted to comprise N+1 bytes, an initial byte of said N+1 bytes being adapted to comprise a synchronization bit sequence.

30 17. The external accessory (102) of claim 16, wherein a second of said N+1 bytes is adapted to comprise mode bits for defining a meaning of the remainder of said N+1 bytes.

18. The external accessory (102) of claim 17, wherein N is adapted to be an odd integer.

35 19. The external accessory (102) of claim 18, wherein said clock bit of a last byte of said N+1 bytes is adapted to be of an opposite polarity than said clock bit of said initial byte of said N+1 bytes.

20. The external accessory (102) of claim 19, further comprising means for setting a second bit of each of a respective third and higher-order of said N+1 bytes to an opposite polarity as said clock bit of each of said respective third and higher-order of said N+1 bytes.

40 21. The external accessory (102) of claim 15, wherein said digital signal processor (116) is adapted to repeatedly transmit a same control data byte for a predetermined number of occurrences of said second time slot.

45 22. The external accessory (102) of any one of claims 15 to 21, further comprising a CODEC (120) coupled to said digital signal processor (116).

23. A system for communicating both voice and control data, the system comprising:

50 the portable communication device (100) of any one of claims 8 to 14;
the external accessory (102) of any one of claims 15 to 22; and
a data bus (101) coupled to said portable communication device (100) and to said external accessory (102).

Patentansprüche

55 1. Ein Verfahren zum Kommunizieren von beidem, Sprach- und Steuerdaten, zwischen einer tragbaren Kommunikationsvorrichtung (100) und einem externen Zusatzgerät (102) über einen Datenbus (101), wobei das Verfahren folgende Schritte aufweist:

EP 1 151 545 B1

- Formatieren (106, 116) einer Sequenz von Bits in eine Wiederholungssequenz von ersten Zeitschlitzten und zweiten Zeitschlitzten;
Vorsehen (106, 116) eines ersten Bits eines jeden der zweiten Zeitschlitzte mit einem Taktbit, das zwischen einem hohen Wert und einem niedrigen Wert alterniert, und zwar zwischen aufeinander folgenden zweiten Zeitschlitzten;
Senden (106, 116) der Sprachdaten in dem ersten Zeitschlitz; und
Senden (106, 116) der Steuerdaten in dem zweiten Zeitschlitz.
- 5
2. Verfahren gemäß Anspruch 1, wobei die Sequenz von zweiten Zeitschlitzten N+1 Bytes aufweist, wobei ein Anfangsbyte der N+1 Bytes weiterhin eine Synchronisationsbitsequenz aufweist.
- 10
3. Verfahren nach Anspruch 2, wobei ein zweites der N+1 Bytes Modusbits aufweist zum Definieren einer Bedeutung des Rests der N+1 Bytes.
- 15
4. Verfahren nach Anspruch 3, wobei N ein ungerader Integer bzw. ganze Zahl ist.
5. Verfahren nach Anspruch 4, wobei das Taktbit eines letzten Bytes der N+1 Bytes eine entgegengesetzte Polarität besitzt als das Taktbit des Anfangsbytes der N+1 Bytes.
- 20
6. Verfahren nach Anspruch 5, das weiterhin den Schritt des Einstellens eines zweiten Bits eines jeden jeweiligen dritten und höherrangigen Bytes der N+1 Bytes auf eine entgegengesetzte Polarität als das Taktbit eines jeden der dritten und höherrangigen Bytes der N+1 Bytes aufweist.
- 25
7. Verfahren nach Anspruch 1, das weiterhin den Schritt des wiederholenden Sendens desselben Steuerdatenbytes für eine vorbestimmte Anzahl der Auftritte des zweiten Zeitschlitzes aufweist.
8. Eine tragbare Kommunikationsvorrichtung (100) zum Kommunizieren von beidem, Sprach- und Steuerdaten, zu einem externen Zusatzgerät (102) über einen Datenbus (101), wobei die Vorrichtung (100) Folgendes aufweist:
- 30
- einen Mikroprozessor (106) angepasst zum
Formatieren einer Sequenz von Bits in eine Wiederholungssequenz von ersten Zeitschlitzten und zweiten Zeitschlitzten,
Vorsehen eines ersten Bits eines jeden der zweiten Zeitschlitzte mit einem Taktbit, das zwischen einem hohen Wert und einem niedrigen Wert alterniert, und zwar zwischen aufeinanderfolgenden zweiten Zeitschlitzten, und
Senden der Sprachdaten in dem ersten Zeitschlitz und der Steuerdaten in dem zweiten Zeitschlitz.
- 35
9. Vorrichtung (100) nach Anspruch 8, wobei die Sequenz von zweiten Zeitschlitzten angepasst ist, um N+1 Bytes aufzuweisen, wobei ein Anfangsbyte der N+1 Bytes angepasst ist, um eine Synchronisationsbitsequenz aufzuweisen.
- 40
10. Vorrichtung (100) nach Anspruch 9, wobei ein zweites der N+1 Bytes angepasst ist zum Aufweisen von Modusbits zum Definieren einer Bedeutung des Rests der N+1 Bytes.
- 45
11. Vorrichtung (100) nach Anspruch 10, wobei N angepasst ist eine ungerade ganze Zahl zu sein.
12. Vorrichtung (100) nach Anspruch 11, wobei das Taktbit eines letzten Bytes der N+1 Bytes angepasst ist, eine entgegengesetzte Polarität zu besitzen als das Taktbit des Anfangsbytes der N+1 Bytes.
- 50
13. Vorrichtung (100) nach Anspruch 12, das weiterhin Mittel aufweist zum Einstellen eines zweiten Bits eines jeden jeweiligen Dritten oder höherrangigen der N+1 Bytes auf eine entgegengesetzte Polarität als das Taktbit eines jeden der jeweiligen dritten und höherrangigen Bytes der N+1 Bytes.
- 55
14. Vorrichtung (100) nach einem der Ansprüche 8 bis 13, die weiterhin Folgendes aufweist:
- einen Sprachcodierer (108) gekoppelt an den Mikroprozessor (106);
einen Sprachdecoder (110) gekoppelt an den Mikroprozessor (106);
ein Leseregister (104) gekoppelt an den Codierer (108) und den Mikroprozessor (106);
ein Schreibregister (112) gekoppelt an den Mikroprozessor (106); und

EP 1 151 545 B1

einen Multiplexer (114) gekoppelt an den Decodierer (110) und das Schreibregister (112).

- 5 15. Ein externes Zusatzgerät (102) zum Kommunizieren von beidem, Sprach- und Steuerdaten zu einer tragbaren Kommunikationsvorrichtung (100) über einen Datenbus (101), wobei das externe Zusatzgerät (102) Folgendes aufweist:

10 einen Digitalsignalprozessor (116) angepasst zum Formatieren einer Sequenz von Bits in eine Wiederholungssequenz von ersten Zeitschlitz und zweiten Zeitschlitz, Vorsehen eines ersten Bits eines jeden der zweiten Zeitschlitz mit einem Taktbit, das zwischen einem hohen Wert und einem niedrigen Wert alterniert, und zwar zwischen aufeinanderfolgenden Zeitschlitz, und Senden der Sprachdaten in dem ersten Zeitschlitz und der Steuerdaten in dem zweiten Zeitschlitz.

- 15 16. Externes Zusatzgerät (102) nach Anspruch 15, wobei die Sequenz von zweiten Zeitschlitz angepasst ist zum Aufweisen von N+1 Bytes, wobei ein Anfangsbyte der N+1 Bytes angepasst ist zum Aufweisen einer Synchronisationsbitsequenz.

17. Externes Zusatzgerät (102) nach Anspruch 16, wobei ein zweites der N+1 Bytes angepasst ist zum Aufweisen von Modusbits zum Definieren einer Bedeutung des Rests der N+1 Bytes.

- 20 18. Externes Zusatzgerät (102) nach Anspruch 17, wobei N angepasst ist als eine ungerade ganze Zahl.

19. Externes Zusatzgerät (102) nach Anspruch 18, wobei das Taktbit des letzten Bytes der N+1 Bytes angepasst ist auf eine entgegengesetzte Polarität als das Taktbit des Anfangsbytes der N+1 Bytes.

- 25 20. Externes Zusatzgerät (102) nach Anspruch 19, das weiterhin Mittel aufweist zum Einstellen eines zweiten Bits eines jeden jeweiligen Dritten und höherrangigen Bytes der N+1 Bytes auf eine entgegengesetzte Polarität als das Taktbit eines jeden der jeweiligen und höherrangigen Bytes der N+1 Bytes.

- 30 21. Externes Zusatzgerät (102) nach Anspruch 15, wobei der Digitalsignalverarbeiter bzw. -prozessor (116) angepasst ist zum wiederholenden Senden eines gleichen Steuerdatenbytes für eine vorbestimmte Anzahl von Auftritten des zweiten Zeitschlitzes.

- 35 22. Externes Zusatzgerät (102) nach einem der Ansprüche 15 bis 21, das weiterhin einen CODEC (120) aufweist, der an einen Digitalsignalverarbeiter (116) gekoppelt ist.

23. Ein System zum Kommunizieren von beidem, Sprach- und Steuerdaten, wobei das System Folgendes aufweist:

40 die tragbare Kommunikationsvorrichtung (100) nach einem der Ansprüche 8 bis 14;
das externe Zusatzgerät (102) nach einem der Ansprüche 15 bis 22; und
einen Datenbus (101) gekoppelt an die tragbare Kommunikationsvorrichtung (100) und das externe Zusatzgerät (102).

Revendications

- 45 1. Procédé pour faire communiquer de la voix et des données de commande entre un appareil de communication portable (100) et un accessoire externe (102) sur un bus de données (101), le procédé comprenant les étapes consistant à :

50 formater (106, 116) une séquence de bits en une séquence répétée de premiers intervalles de temps et de deuxièmes intervalles de temps ;
munir (106, 116) un premier bit de chacun desdits deuxièmes intervalles de temps d'un bit d'horloge qui alterne entre une valeur haute et une valeur basse comme entre les deuxièmes intervalles de temps consécutifs ;
transmettre (106, 116) lesdites données de voix dans ledit premier intervalle de temps ; et
55 transmettre (106, 116) lesdites données de commande dans ledit deuxième intervalle de temps.

2. Procédé selon la revendication 1, dans lequel ladite séquence de deuxièmes intervalles de temps comprend N+1 octets, un octet initial desdits N+1 octets comprenant en outre une séquence de bits de synchronisation.

EP 1 151 545 B1

3. Procédé selon la revendication 2, dans lequel un deuxième desdits N+1 octets comprend des bits de mode pour définir un sens du reste desdits N+1 octets.
- 5 4. Procédé selon la revendication 3, dans lequel N est un entier impair.
- 10 5. Procédé selon la revendication 4, dans lequel ledit bit d'horloge d'un dernier octet desdits N+1 octets est de polarité opposée audit bit d'horloge dudit octet initial desdits N+1 octets.
- 15 6. Procédé selon la revendication 5, comprenant en outre l'étape de réglage d'un deuxième bit de chacun d'un troisième octet et d'octets d'ordre supérieur desdits N+1 octets à une polarité opposée comme ledit bit d'horloge de chacun desdits troisième octet et octets d'ordre supérieur desdits N+1 octets.
- 20 7. Procédé selon la revendication 1, comprenant en outre l'étape consistant à transmettre de façon répétée un même octet de données de commande pour un nombre d'occurrences prédéterminé dudit deuxième intervalle de temps.
- 25 8. Appareil de communication portable (100) pour communiquer de la voix et des données de commande à un accessoire externe (102) via un bus de données (101), l'appareil (100) comprenant :
- un microprocesseur (106) adapté pour :
- formater une séquence de bits en une séquence répétée de premiers intervalles de temps et de deuxièmes intervalles de temps,
munir un premier bit de chacun desdits deuxièmes intervalles de temps d'un bit d'horloge qui alterne entre une valeur haute et une valeur basse comme entre les deuxièmes intervalles de temps consécutifs, et
transmettre lesdites données de voix dans ledit premier intervalle de temps et lesdites données de commande dans ledit deuxième intervalle de temps.
- 30 9. Appareil (100) selon la revendication 8, dans lequel ladite séquence de deuxième intervalles de temps est adaptée pour comprendre N+1 octets, un octet initial desdits N+1 octets étant adapté pour comprendre une séquence de bits de synchronisation.
- 35 10. Appareil (100) selon la revendication 9, dans lequel un deuxième desdits N+1 octets est adapté pour comprendre des bits de mode pour définir un sens du reste desdits N+1 octets.
- 40 11. Appareil (100) selon la revendication 10, dans lequel N est adapté pour être un entier impair.
- 45 12. Appareil (100) selon la revendication 11, dans lequel ledit bit d'horloge d'un dernier octet desdits N+1 octets est adapté pour être d'une polarité opposée audit bit d'horloge dudit octet initial desdits N+1 octets.
- 50 13. Appareil (100) selon la revendication 12, comprenant en outre un moyen pour régler un deuxième bit de chacun d'un troisième octet respectif et d'octets d'ordre supérieur desdits N+1 octets à une polarité opposée comme ledit bit d'horloge de chacun desdits troisième octet respectif et octets d'ordre supérieur desdits N+1 octets.
- 55 14. Appareil (100) selon l'une quelconque des revendications 8 à 13, comprenant en outre :
- un codeur de voix (108) couplé audit microprocesseur (106) ;
un décodeur de voix (110) couplé audit microprocesseur (106) ;
un registre de lecture (104) couplé audit codeur (108) et audit microprocesseur (106) ;
un registre d'écriture (112) couplé audit microprocesseur (106) ; et
un multiplexeur (114) couplé audit décodeur (110) et audit registre d'écriture (112).
15. Accessoire externe (102) pour communiquer de la voix et des données de commande à un appareil de communication portable (100) via un bus de données (101), l'accessoire externe (102) comprenant :
- un processeur de signaux numériques (116) adapté pour :
- formater une séquence de bits en une séquence répétée de premiers intervalles de temps et de deuxièmes intervalles de temps,

EP 1 151 545 B1

munir un premier bit de chacun desdits deuxièmes intervalles de temps d'un bit d'horloge qui alterne entre une valeur haute et une valeur basse comme entre les deuxièmes intervalles de temps consécutifs, et transmettre lesdites données de voix dans ledit premier intervalle de temps et lesdites données de commande dans ledit deuxième intervalle de temps.

- 5
16. Accessoire externe (102) selon la revendication 15, dans lequel ladite séquence de deuxième intervalles de temps est adaptée pour comprendre N+1 octets, un octet initial desdits N+1 octets étant adapté pour comprendre une séquence de bits de synchronisation.
- 10
17. Accessoire externe (102) selon la revendication 16, dans lequel un deuxième desdits N+1 octets est adapté pour comprendre des bits de mode pour définir un sens du reste desdits N+1 octets.
18. Accessoire externe (102) selon la revendication 17, dans lequel N est adapté pour être un entier impair.
- 15
19. Accessoire externe (102) selon la revendication 18, dans lequel ledit bit d'horloge d'un dernier octet desdits N+1 octets est adapté pour être d'une polarité opposée audit bit d'horloge dudit octet initial desdits N+1 octets.
- 20
20. Accessoire externe (102) selon la revendication 19, comprenant en outre un moyen pour régler un deuxième bit de chacun d'un troisième octet respectif et d'octets d'ordre supérieur desdits N+1 octets à une polarité opposée comme ledit bit d'horloge de chacun desdits troisième octet respectif et octets d'ordre supérieur desdits N+1 octets.
- 25
21. Accessoire externe (102) selon la revendication 15, dans lequel ledit processeur de signaux numériques (116) est adapté pour transmettre de manière répétée un même octet de données de commande pour un nombre d'occurrences prédéterminé dudit deuxième intervalle de temps.
- 30
22. Accessoire externe (102) selon l'une quelconque des revendications 15 à 21, comprenant en outre un CODEC (120) couplé audit processeur de signaux numériques (116).
- 35
23. Système pour faire communiquer de la voix et des données de commande, le système comprenant :
- 40
- l'appareil de communication portable (100) de l'une quelconque des revendications 8 à 14 ;
l'accessoire externe (102) de l'une quelconque des revendications 15 à 22 ; et
un bus de données (101) couplé audit appareil de communication portable (100) et audit accessoire externe (102).
- 45
- 50
- 55

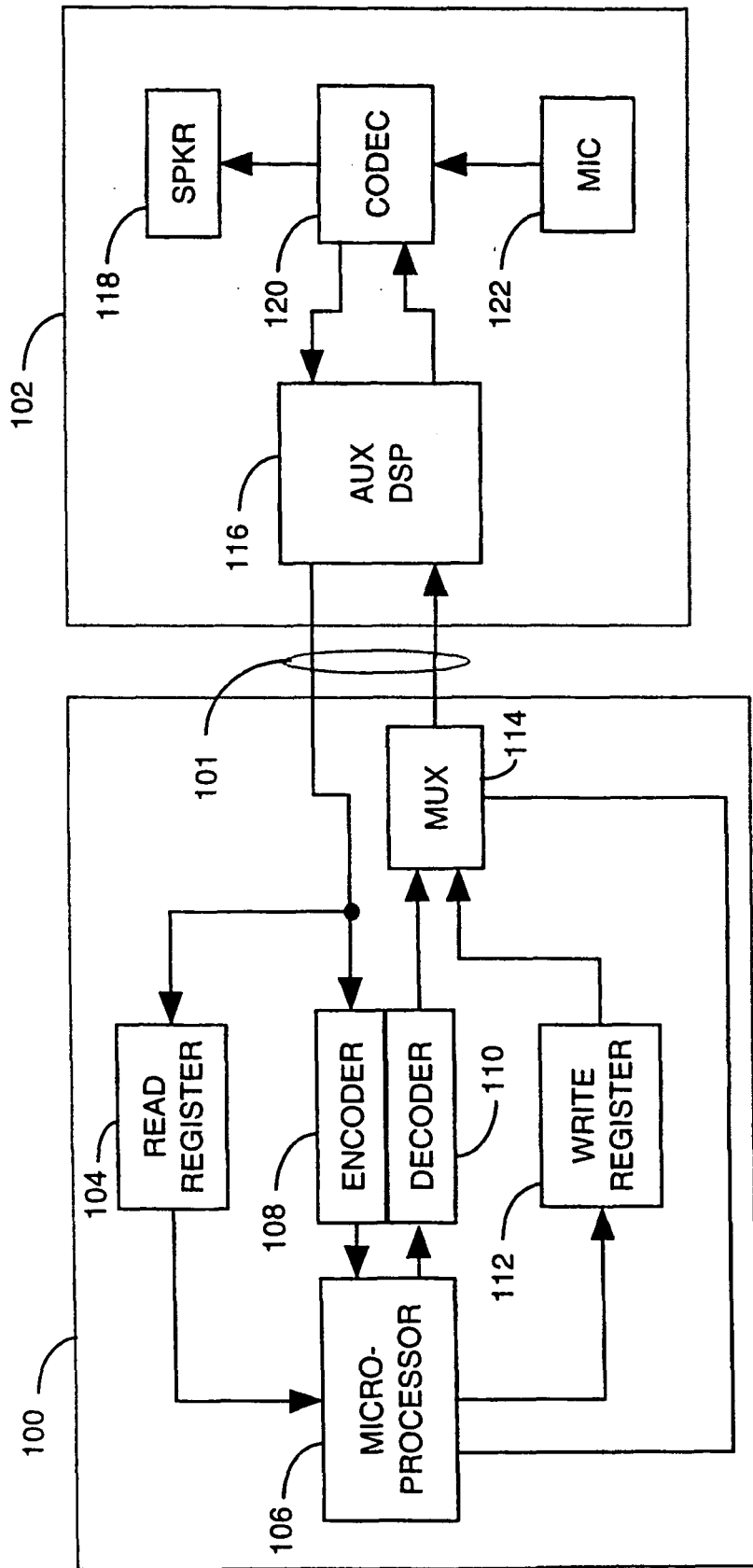

FIG. 1

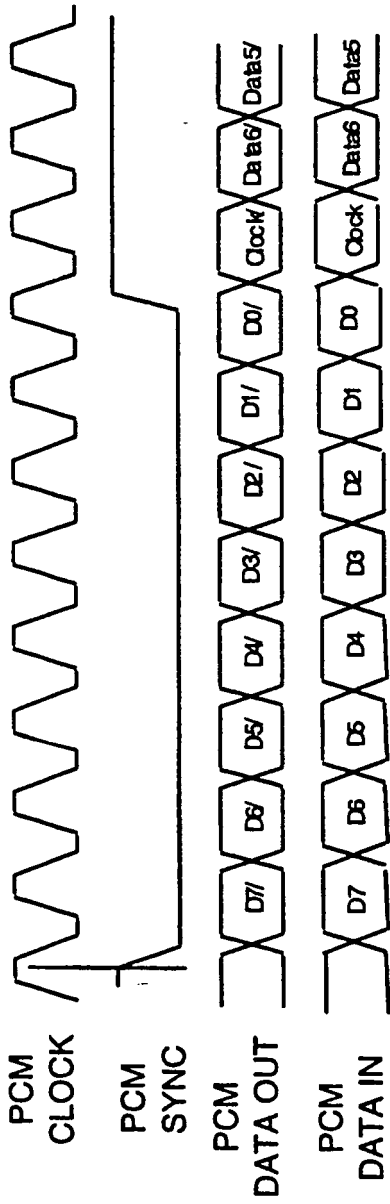

FIG. 2A

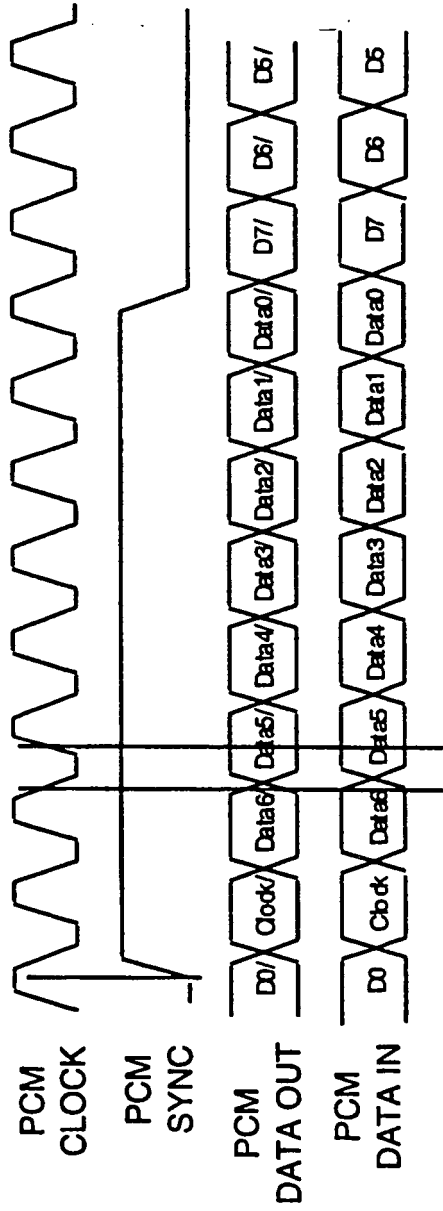

FIG. 2B