



US 20190201783A1

(19) **United States**

(12) **Patent Application Publication**  
**Higgins et al.**

(10) **Pub. No.: US 2019/0201783 A1**

(43) **Pub. Date: Jul. 4, 2019**

(54) **HAND-HELD CONTROLLER USING SENSORS FOR HAND DISAMBIGUATION**

(52) **U.S. CL.**  
CPC ..... *A63F 13/214* (2014.09); *A63F 13/213* (2014.09); *A63F 13/24* (2014.09)

(71) Applicant: **Facebook Technologies, LLC**, Menlo Park, CA (US)

(72) Inventors: **Jason Higgins**, Seattle, WA (US); **Peter Wesley Bristol**, Seattle, WA (US); **Glen Jason Tompkins**, Woodinville, WA (US); **Khaled Boulos**, Seattle, WA (US)

(57) **ABSTRACT**

A hand-held controller includes a handle extending in a longitudinal direction. The handle is shaped and dimensioned to be grasped by a hand of a user. A ring is attached to an end of the handle and surrounds a thumb of the user when the handle is grasped by the hand of the user. The ring has an annular surface defining a plane that forms a predetermined angle with respect to the longitudinal direction. The ring also has a curved outer surface. A sensor is embedded within the ring or mounted on a side surface of the handle to detect whether the hand of the user grasping the handle is a right hand of the user or a left hand of the user.

(21) Appl. No.: **15/858,416**

(22) Filed: **Dec. 29, 2017**

**Publication Classification**

(51) **Int. Cl.**  
*A63F 13/214* (2006.01)  
*A63F 13/24* (2006.01)  
*A63F 13/213* (2006.01)

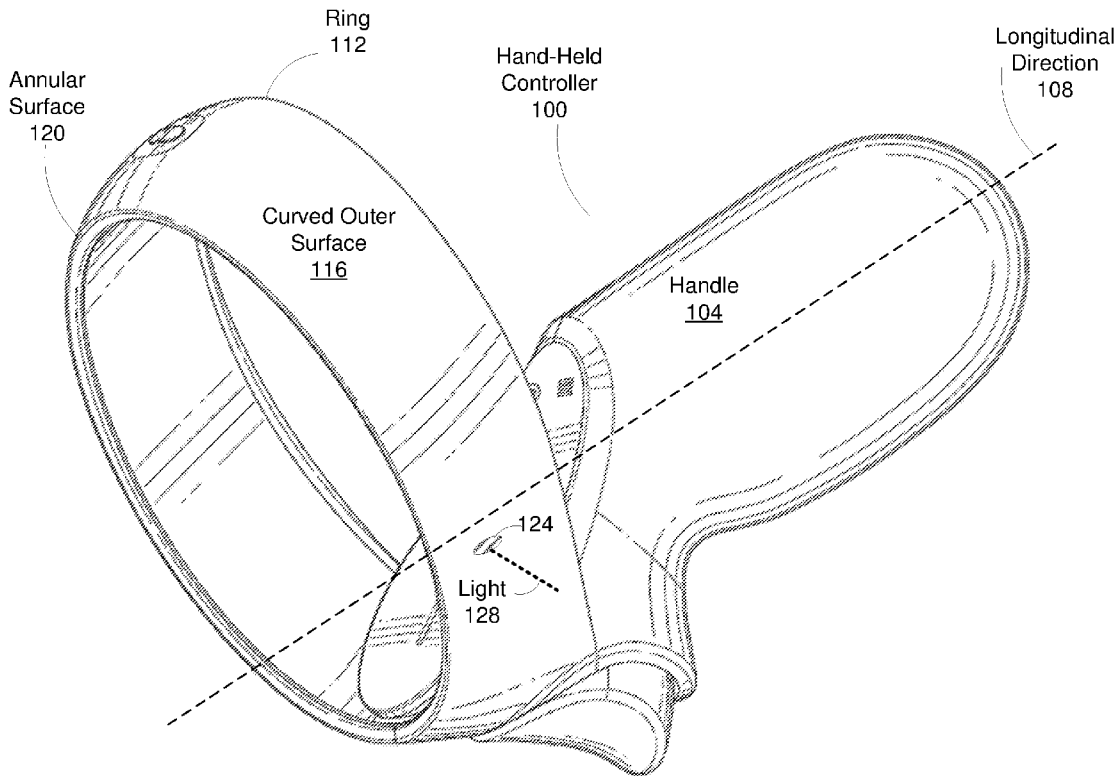

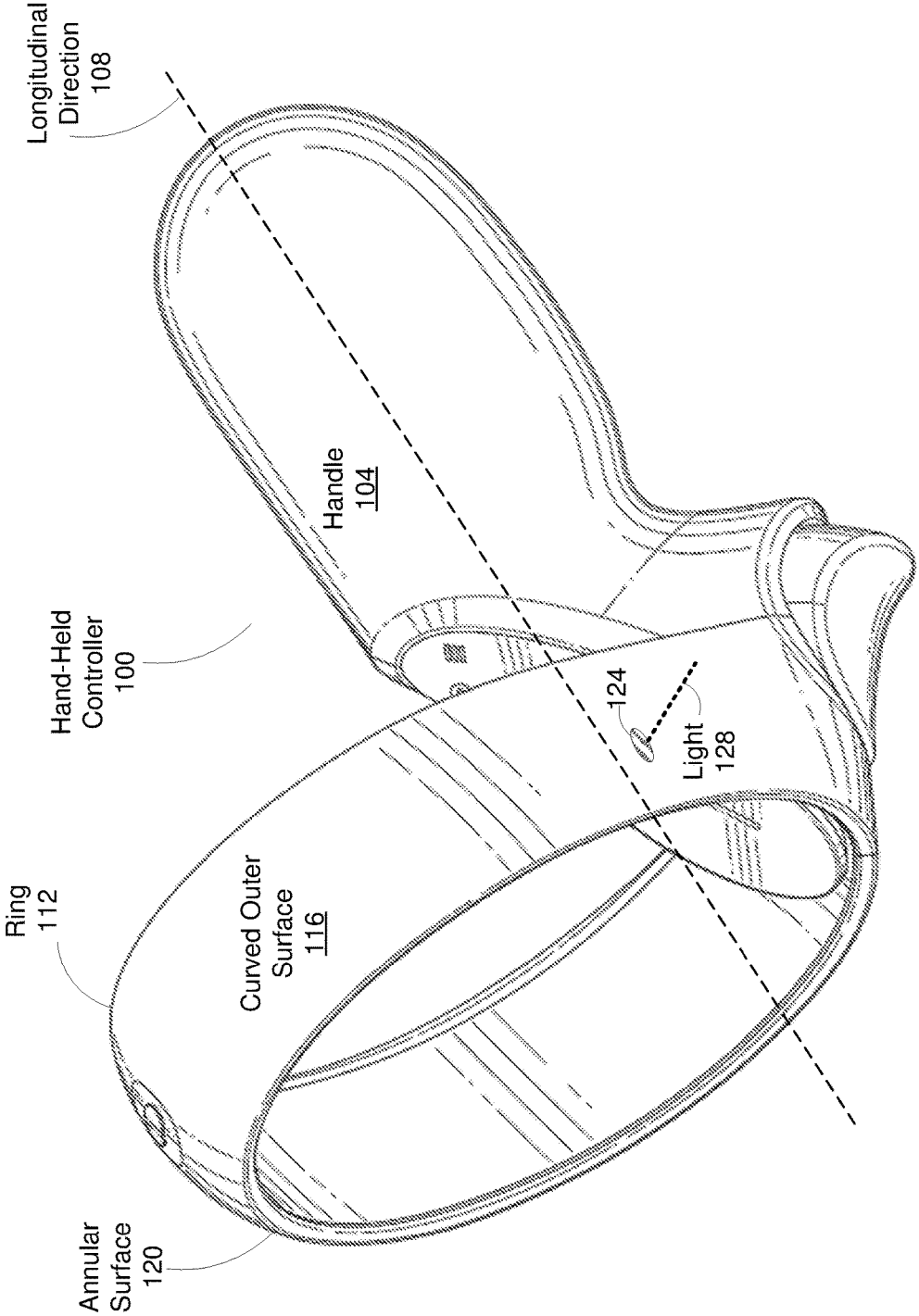

FIG. 1A

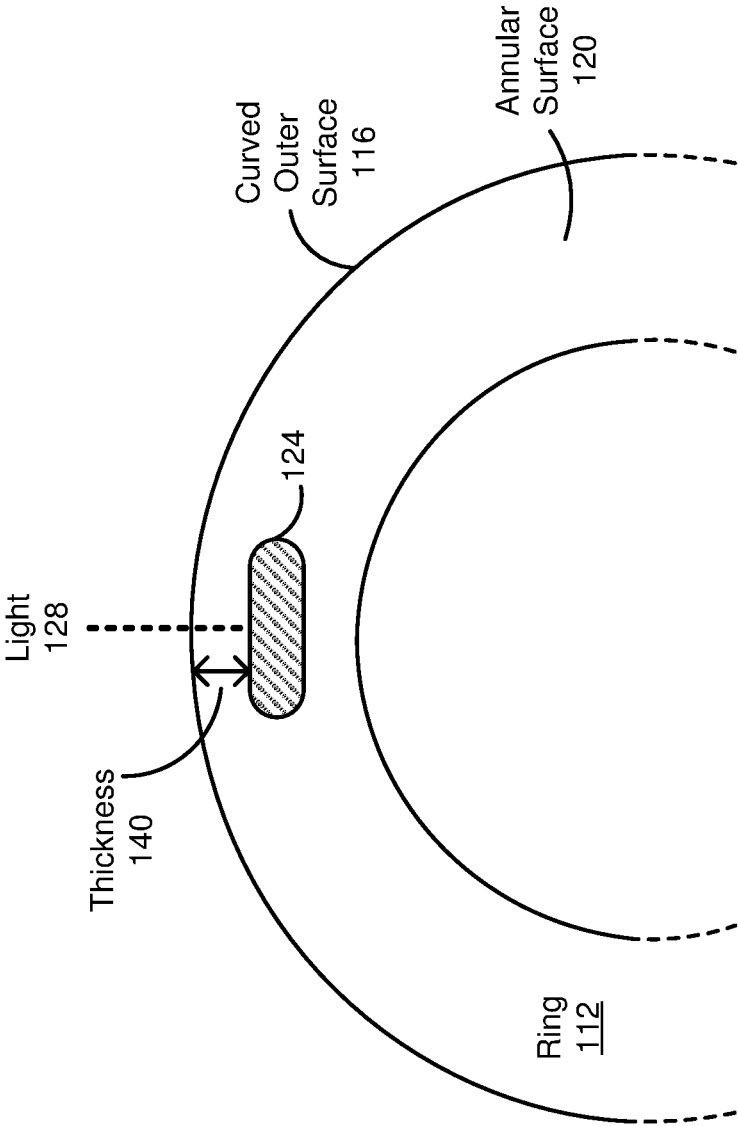

FIG. 1B

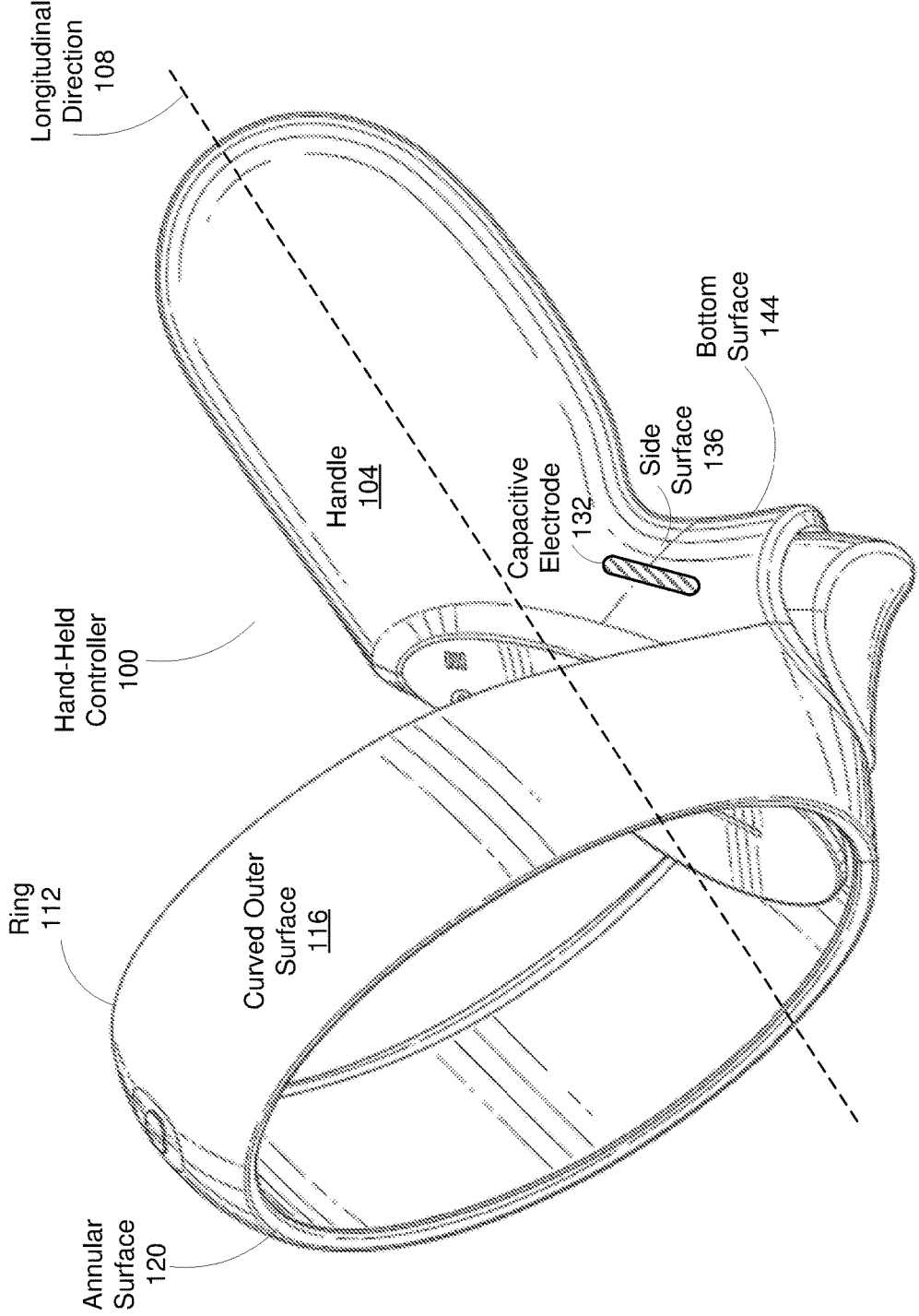
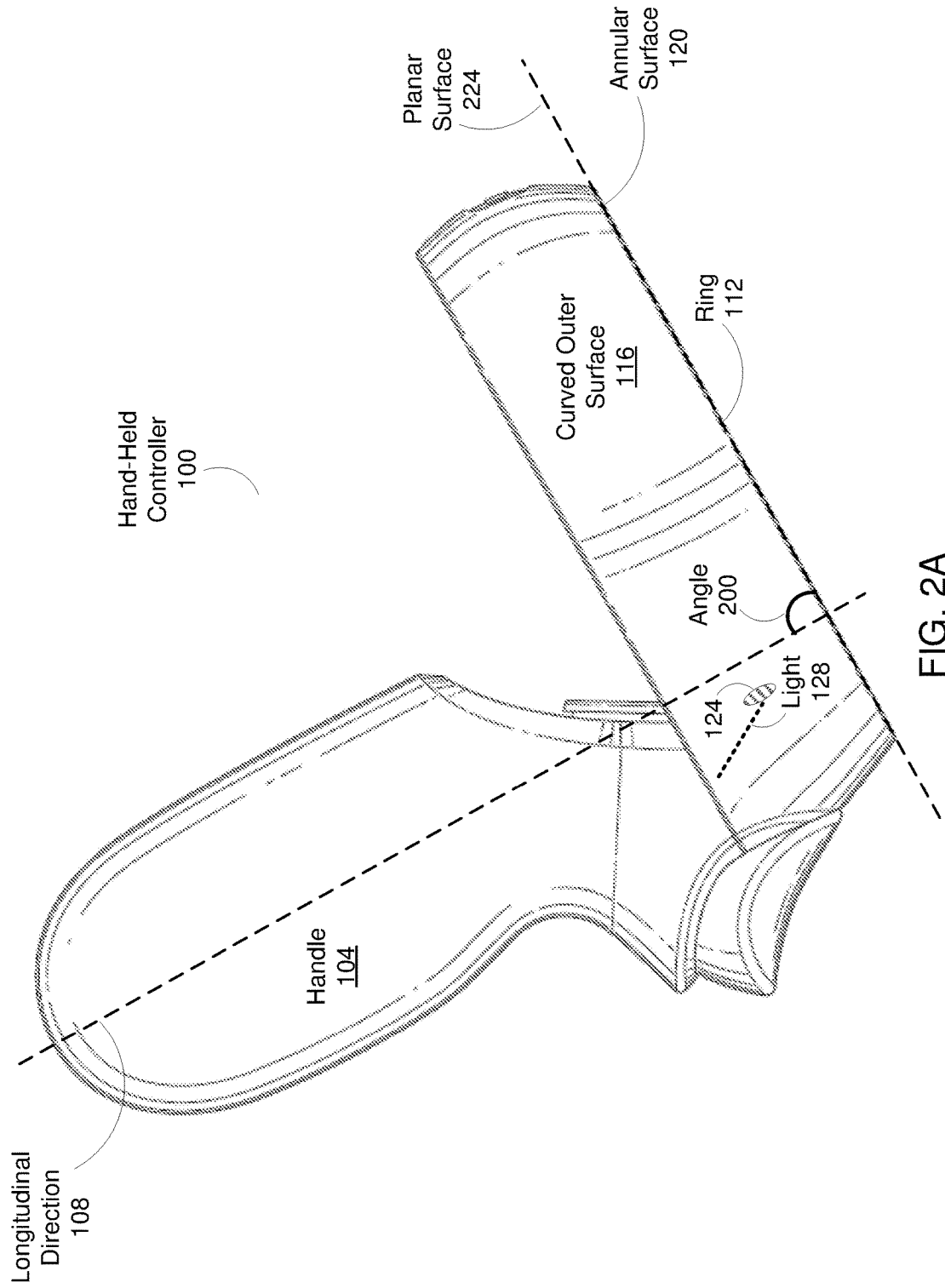
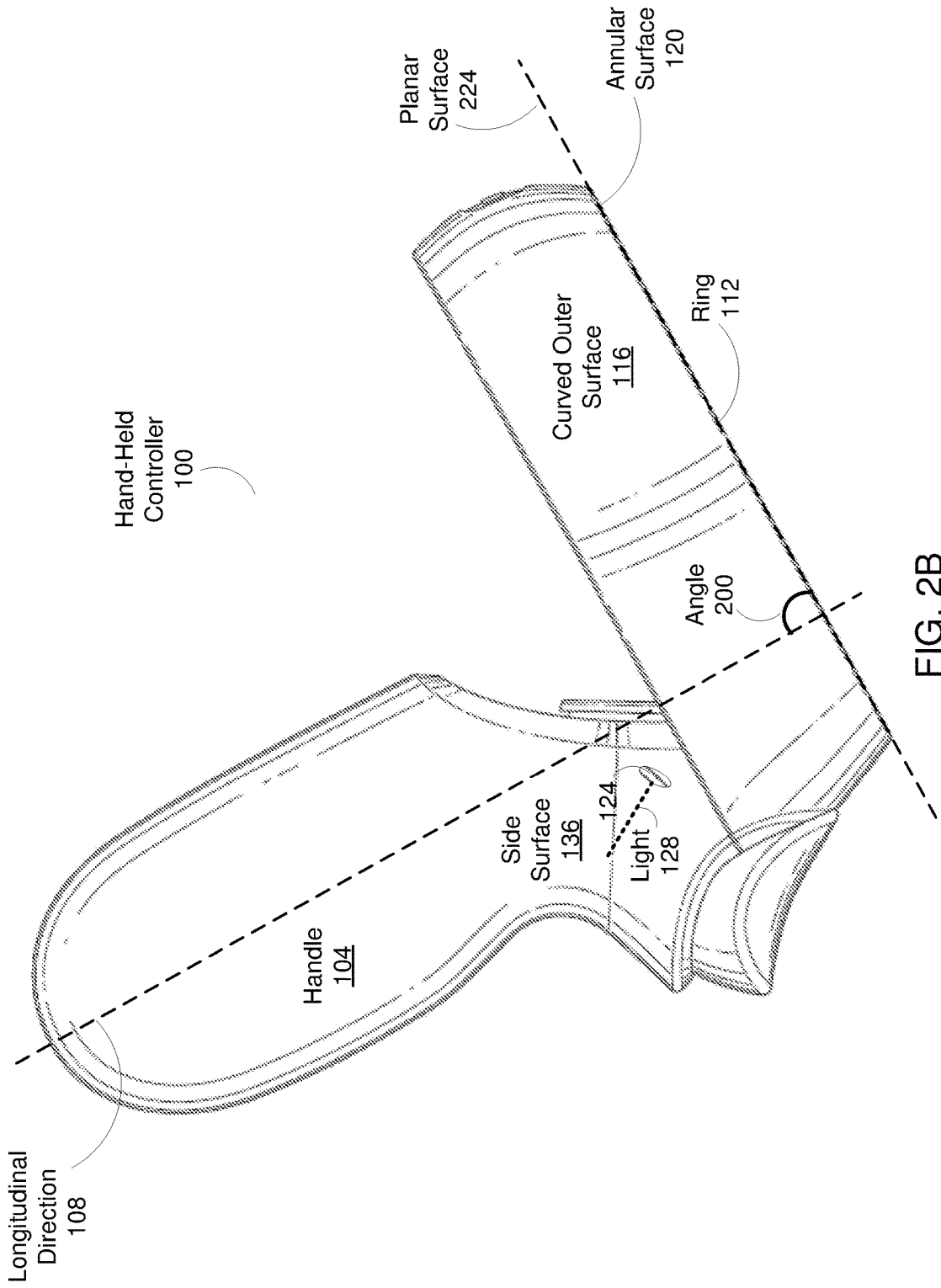
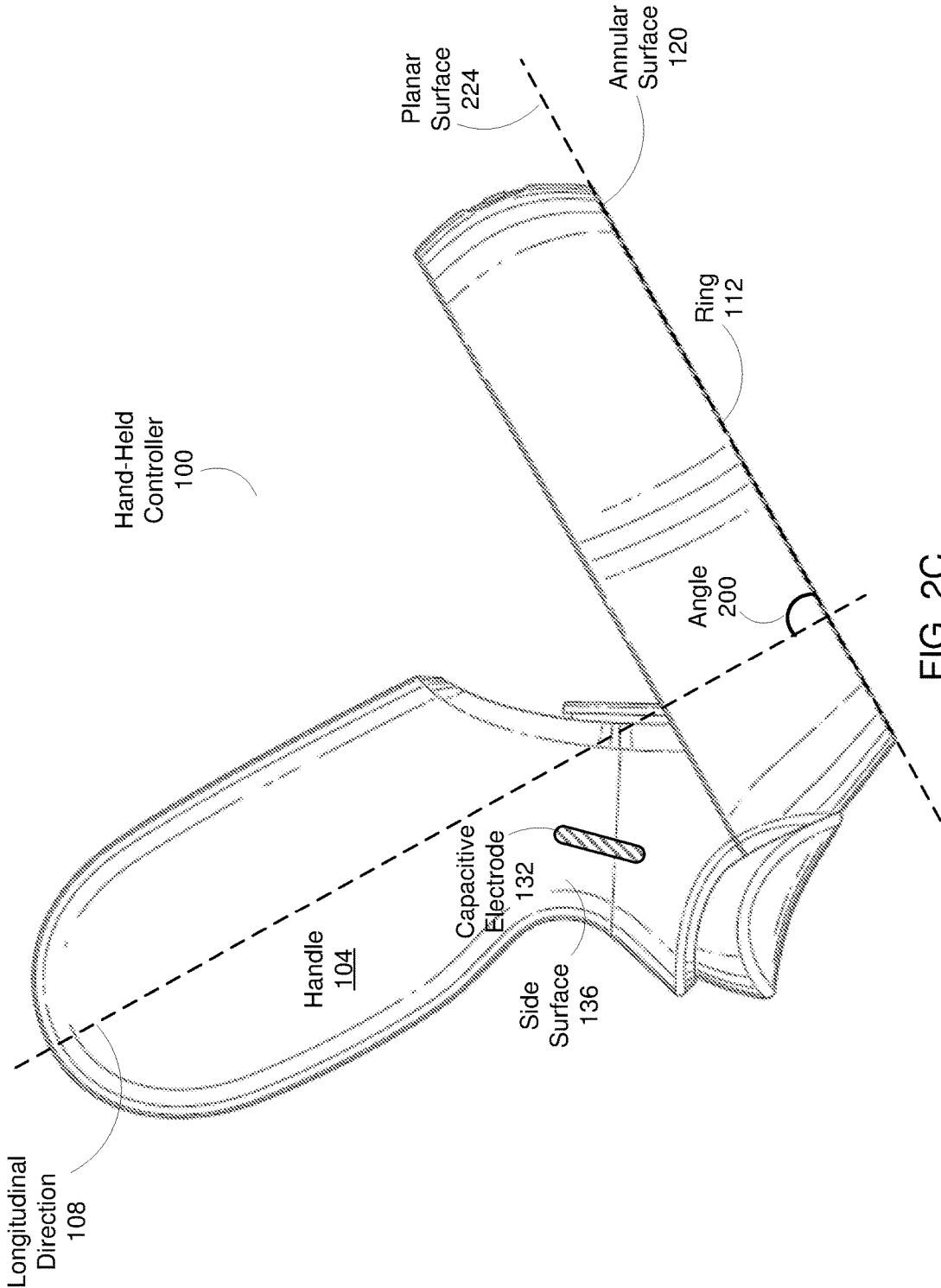

FIG. 1C







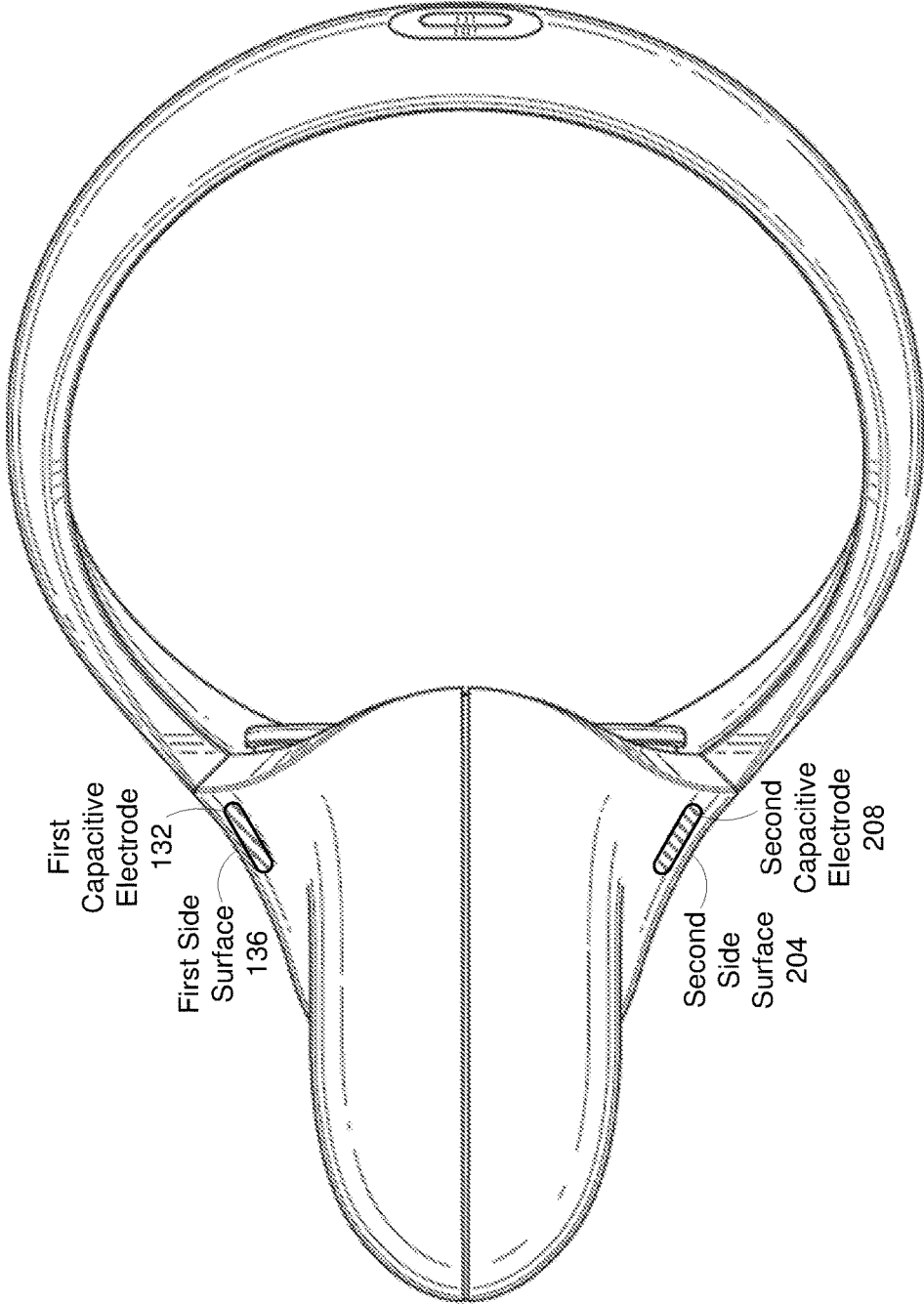

FIG. 2D



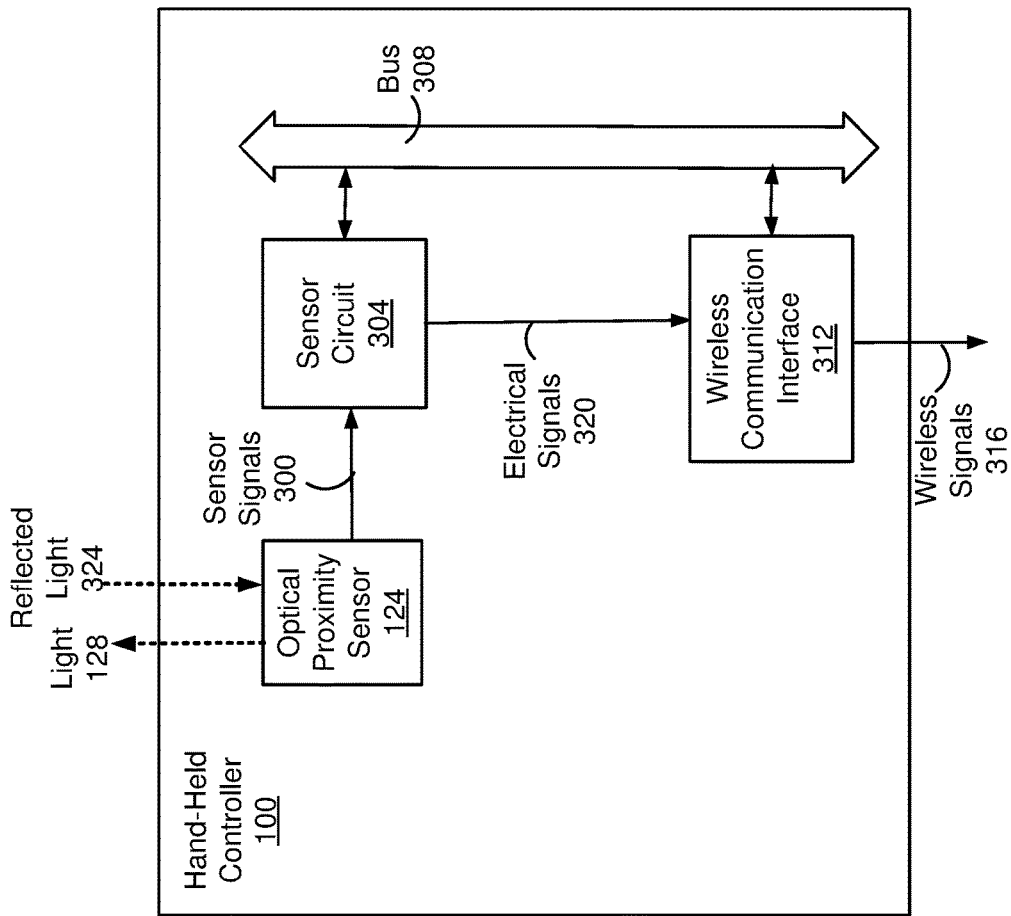

FIG. 3A

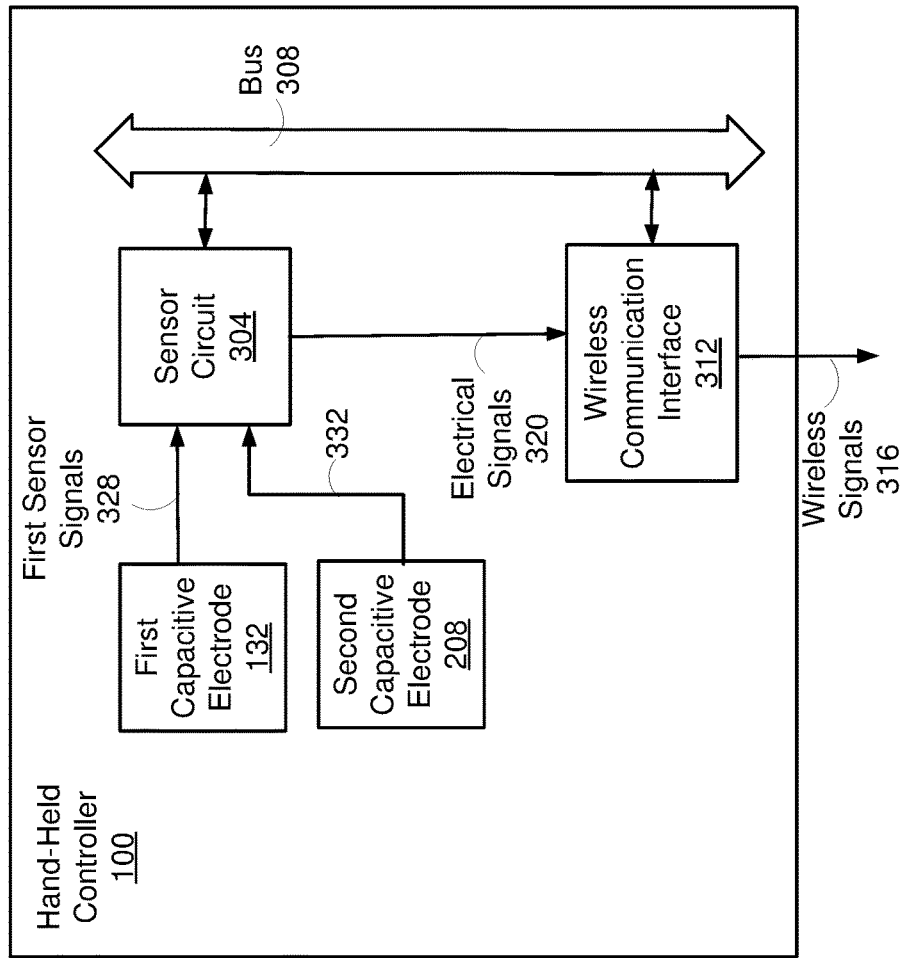

FIG. 3B

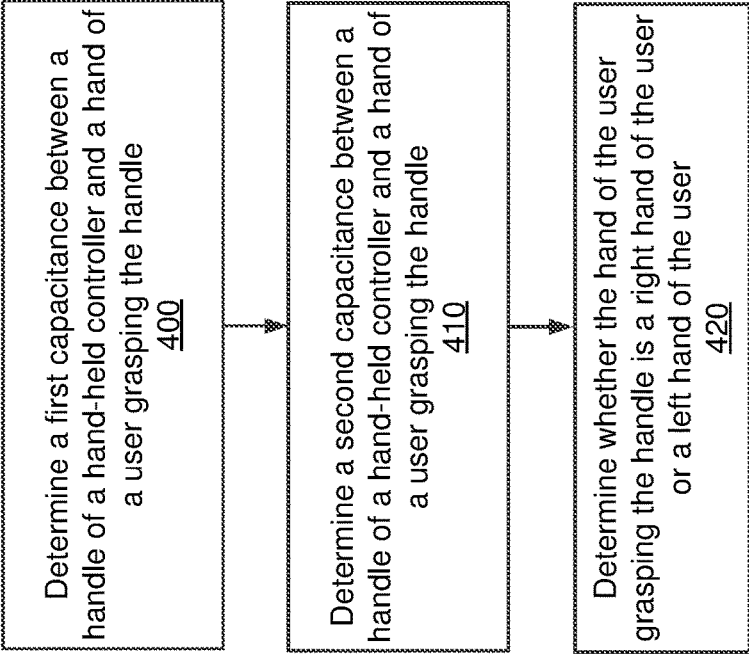

FIG. 4

## HAND-HELD CONTROLLER USING SENSORS FOR HAND DISAMBIGUATION

### BACKGROUND

#### Field of the Disclosure

[0001] The present disclosure generally relates to artificial reality controllers, and specifically to a hand-held controller using sensors for hand disambiguation.

#### Description of the Related Arts

[0002] Artificial reality systems may include a controller to translate movement of the user's body into tangible action in a virtual world. Some controllers provide vibration feedback to Android or iOS artificial reality headsets for motion-based gaming. A controller may be equipped with a gyroscope, an accelerometer, or terrestrial magnetic field sensor to trace motion back to a game, allowing intuitive gameplay as if the player is within the game.

### SUMMARY

[0003] Embodiments relate to a hand-held controller to track a user's hand motion, position, natural gestures, and finger movement to create a sense of hand presence for more realistic and tactile artificial reality. The controller may let the user make social gestures like point, wave, and give a thumbs-up or manipulate objects in the virtual space, pick up toys or fire laser guns with intuitive, natural hand movement.

[0004] In one embodiment, the hand-held controller includes a handle extending in a longitudinal direction. The handle is shaped and dimensioned to be grasped by a hand of a user. A ring is attached to an end of the handle and has an annular surface defining a plane that forms a predetermined angle with respect to the longitudinal direction. The ring also has a curved outer surface. An optical proximity sensor is embedded within the ring or the handle to detect whether the hand of the user grasping the handle is a right hand of the user or a left hand of the user.

[0005] In one embodiment, the optical proximity sensor emits light in a direction of the hand of the user grasping the handle.

[0006] In one embodiment, the light is infrared light.

[0007] In one embodiment, the optical proximity sensor includes a photodiode or phototransistor to receive reflected light from the hand of the user grasping the handle and generate sensor signals corresponding to the reflected light. The sensor signals indicate whether the hand of the user grasping the handle is the right hand of the user or the left hand of the user.

[0008] In one embodiment, the optical proximity sensor determines whether the hand of the user grasping the handle is the right hand of the user or the left hand of the user based on whether a time interval between the optical proximity sensor emitting light in a direction of the hand of the user grasping the handle and the optical proximity sensor receiving reflected light from the hand of the user grasping the handle is higher than a threshold time period.

[0009] In one embodiment, at least part of the ring or the handle is transparent to infrared light.

[0010] In one embodiment, at least part of the light emitted by the optical proximity sensor exits through the curved outer surface of the ring or a side surface of the handle.

[0011] In one embodiment, a hand-held controller includes a handle extending in a longitudinal direction. The handle is shaped and dimensioned to be grasped by a hand of a user. A ring is attached to an end of the handle and has an annular surface defining a plane that forms a predetermined angle with respect to the longitudinal direction and a curved outer surface. A first capacitive electrode is mounted on a first side surface of the handle and a second capacitive electrode is mounted on a second side surface of the handle opposite to the first side surface. The first capacitive electrode and the second capacitive electrode detect whether the hand of the user grasping the handle is a right hand of the user or a left hand of the user.

[0012] In one embodiment, the first capacitive electrode and the second capacitive electrode are contacted by the hand of the user grasping the handle.

[0013] In one embodiment, the first capacitive electrode determines a first capacitance between the handle and the hand of the user grasping the handle. The second capacitive electrode determines a second capacitance between the handle and the hand of the user grasping the handle.

[0014] In one embodiment, the first capacitive electrode generates first sensor signals corresponding to a first capacitance between the handle and the hand of the user grasping the handle. The second capacitive electrode generates second sensor signals corresponding to a second capacitance between the handle and the hand of the user grasping the handle.

[0015] In one embodiment, the first capacitance is a capacitance between the handle and a finger of the hand of the user grasping the handle. The second capacitance is a capacitance between the handle and a palm of the hand of the user grasping the handle.

[0016] In one embodiment, a sensor circuit coupled to the first capacitive electrode and the second capacitive electrode receives the first sensor signals from the first capacitive electrode. The sensor circuit receives the second sensor signals from the second capacitive electrode and determines whether the hand of the user grasping the handle is the right hand of the user or the left hand of the user based on whether the first sensor signals are stronger than the second sensor signals.

[0017] In one embodiment, a sensor circuit is coupled to the first capacitive electrode and the second capacitive electrode. The sensor circuit determines whether the hand of the user grasping the handle is the right hand of the user or the left hand of the user based on whether the first capacitance is higher than the second capacitance.

[0018] In one embodiment, a wireless communication interface transmits wireless signals indicating whether the hand of the user grasping the handle is a right hand of the user or a left hand of the user.

[0019] In one embodiment, a first capacitive electrode mounted on a first side surface of a handle of a hand-held controller determines a first capacitance between the handle and a hand of the user grasping the handle. A second capacitive electrode mounted on a second side surface of the handle determines a second capacitance between the handle and the hand of the user grasping the handle. It is determined whether the hand of the user grasping the handle is the right hand of the user or the left hand of the user based on whether the first capacitance is higher than the second capacitance.

[0020] In one embodiment, the first capacitive electrode generates first sensor signals corresponding to the first

capacitance. The second capacitive electrode generates second sensor signals corresponding to the second capacitance.

**[0021]** In one embodiment, the determining of whether the hand of the user grasping the handle is the right hand of the user or the left hand of the user includes determining whether the first sensor signals are stronger than the second sensor signals.

**[0022]** In one embodiment, the first capacitance is a capacitance between the handle and a finger of the hand of the user grasping the handle.

**[0023]** In one embodiment, the second capacitance is a capacitance between the handle and a palm of the hand of the user grasping the handle.

#### BRIEF DESCRIPTION OF THE DRAWINGS

**[0024]** The teachings of the embodiments can be readily understood by considering the following detailed description in conjunction with the accompanying drawings.

**[0025]** FIG. 1A is an example schematic perspective view of a hand-held controller including an optical proximity sensor, in accordance with an embodiment.

**[0026]** FIG. 1B is an example cross sectional view of a ring of a hand-held controller including an optical proximity sensor, in accordance with an embodiment.

**[0027]** FIG. 1C is an example schematic perspective view of the hand-held controller including a capacitive electrode, in accordance with an embodiment.

**[0028]** FIG. 2A is an example schematic side view of the hand-held controller including an optical proximity sensor, in accordance with an embodiment.

**[0029]** FIG. 2B is an example schematic side view of the hand-held controller including an optical proximity sensor, in accordance with an embodiment.

**[0030]** FIG. 2C is an example schematic side view of the hand-held controller including a capacitive electrode, in accordance with an embodiment.

**[0031]** FIG. 2D is an example schematic planar view of the hand-held controller including a first capacitive electrode and a second capacitive electrode, in accordance with an embodiment.

**[0032]** FIG. 3A is an example schematic block diagram of the hand-held controller including an optical proximity sensor, in accordance with an embodiment.

**[0033]** FIG. 3B is an example schematic block diagram of the hand-held controller including capacitive electrodes, in accordance with an embodiment.

**[0034]** FIG. 4 is a flowchart illustrating an example process for determining whether a hand of a user grasping a hand-held controller is a right hand of the user or a left hand of the user, in accordance with an embodiment.

**[0035]** The figures depict various embodiments for purposes of illustration only.

#### DETAILED DESCRIPTION

**[0036]** In the following description of embodiments, numerous specific details are set forth in order to provide more thorough understanding. However, note that the embodiments may be practiced without one or more of these specific details. In other instances, well-known features have not been described in detail to avoid unnecessarily complicating the description.

**[0037]** Embodiments are described herein with reference to the figures where like reference numbers indicate identi-

cal or functionally similar elements. Also in the figures, the left most digits of each reference number corresponds to the figure in which the reference number is first used.

**[0038]** Embodiments of the invention may include or be implemented in conjunction with an artificial reality system. Artificial reality is a form of reality that has been adjusted in some manner before presentation to a user, which may include, e.g., a virtual reality (VR), an augmented reality (AR), a mixed reality (MR), a hybrid reality, or some combination and/or derivatives thereof. Artificial reality content may include completely generated content or generated content combined with captured (e.g., real-world) content. The artificial reality content may include video, audio, haptic feedback, or some combination thereof, and any of which may be presented in a single channel or in multiple channels (such as stereo video that produces a three-dimensional effect to the viewer). Additionally, in some embodiments, artificial reality may also be associated with applications, products, accessories, services, or some combination thereof, that are used to, e.g., create content in an artificial reality and/or are otherwise used in (e.g., perform activities in) an artificial reality. The artificial reality system that provides the artificial reality content may be implemented on various platforms, including an HMD connected to a host computer system, a standalone HMD, a mobile device or computing system, or any other hardware platform capable of providing artificial reality content to one or more viewers.

**[0039]** Embodiments relate to a hand-held artificial reality controller to track a user's hand motion and position. The hand-held controller includes a handle extending in a longitudinal direction. A ring is attached to an end of the handle and has a curved outer surface. A sensor embedded within the ring or mounted on the handle detects whether the hand of the user grasping the handle is a right hand of the user or a left hand of the user.

#### Example Schematic Perspective View of Hand-Held Controller With Optical Proximity Sensor

**[0040]** FIG. 1A is an example schematic perspective view of a hand-held controller **100** including an optical proximity sensor **124**, in accordance with an embodiment. The hand-held controller **100** may be included in an artificial reality system as a stand-alone controller or as part of a pair of tracked controllers that give a user "hand presence"—the feeling that the user's virtual hands are actually his own. The hand-held controller **100** may enable the user to manipulate objects in a virtual space with precision and intuitive, natural hand movement.

**[0041]** The hand-held controller **100** includes a handle **104** extending in a longitudinal direction **108**. In one embodiment, the handle **104** may be made of an engineering plastic, such as injection-molded polycarbonate (PC)/acrylonitrile butadiene styrene (ABS) or polyamide (nylon). In other embodiments, the handle **104** may be made of wood or metal. The handle **104** may be resistant to impact and abrasion. The material of the handle **104** may exhibit heat resistance, mechanical strength, or rigidity.

**[0042]** The handle **104** is shaped and dimensioned to be grasped by a user's hand for tracking natural gestures and finger movements to create more realistic and tactile artificial reality. For example, the handle may have a cylindrical shape. The handle **104** of the hand-held controller **100** may

bend or curve to balance the weight of the controller **100**, such that it rests naturally in the top of the palm of the user or the crook of the user's fingers. The user may therefore comfortably hold the hand-held controller **100** without dropping it. Even if the user tries to open his hand completely when holding the hand-held controller **100** normally, the user's fingers may catch on the ring **112** and support the hand-held controller **100**'s weight. The ring **112** is attached to an end of the handle **104** and has an annular surface **120**. The ring may be made of engineering plastic. In one embodiment, the ring is made of infrared-transparent polycarbonate. The ring **112** may surround a thumb of the user when the handle **104** is grasped by the user's hand.

[0043] The ring **112** has a curved outer surface **116**, as illustrated in FIG. 1. In one embodiment, an optical proximity sensor **124** is embedded within the ring **112** to detect whether a hand of the user grasping the handle **104** is a right hand of the user or a left hand of the user. Information about which hand is grasping the controller may be transmitted to an artificial reality system for tracking a position or orientation of the user in a computer game or training simulation. Based on which hand is grasping the controller, the artificial reality system may alter the present state of the game or future artificial reality events.

[0044] A proximity sensor is a sensor able to detect the presence of nearby objects without any physical contact. An optical proximity sensor uses emission and reflection of light to detect the presence of nearby objects. For example, the optical proximity sensor **124** may be a photocell (reflective) type sensor, a laser rangefinder, a passive sensor (e.g., charge-coupled devices), some other sensor that uses light reflection, a passive thermal infrared sensor, or a combination thereof. The optical proximity sensor **124** emits light **128** in a direction of the hand of the user grasping the handle **104**, e.g., to determine a distance between the hand and the optical proximity sensor **124**. In one embodiment, the light **128** is infrared light. Infrared light is electromagnetic radiation with longer wavelengths than those of visible light, and is therefore invisible.

[0045] In one embodiment, the optical proximity sensor **124** includes a photodiode or phototransistor to receive reflected light from the hand of the user grasping the handle **104**. A photodiode is a semiconductor device that converts light into an electrical current or voltage when photons from the reflect light are absorbed in the photodiode. A phototransistor is a light-sensitive transistor, e.g., a photobipolar transistor, which is a bipolar transistor encased in a transparent case so that light can reach the base-collector junction.

[0046] In one embodiment, the optical proximity sensor **124** determines whether the hand of the user grasping the handle **104** is the right hand of the user or the left hand of the user based on a distance between the hand and the optical proximity sensor **124**. For example, if the optical proximity sensor **124** is embedded on the left hand side of the ring **112** (as shown in FIG. 1A) and the hand of the user grasping the handle **104** is the left hand, the optical proximity sensor **124** may measure the distance between the optical proximity sensor **124** and the left hand of the user as a finite distance (indicating that the hand of the user grasping the handle is the left hand). On the other hand, if the optical proximity sensor **124** is embedded on the left hand side of the ring **112** as shown in FIG. 1A and the hand of the user grasping the handle **104** is the right hand, the hand will not be in line of

sight of the optical proximity sensor **124**. Therefore the light **128** will not reach the right hand of the user and the light **128** from the optical proximity sensor **124** will not reflect back to the optical proximity sensor **124**, leading to a measurement of "infinite" distance (indicating that the hand of the user grasping the handle is the right hand)

[0047] Similarly, if the optical proximity sensor **124** is embedded on the right hand side of the ring **112** (not shown in FIG. 1A) and the hand of the user grasping the handle **104** is the right hand, the optical proximity sensor **124** may measure the distance between the optical proximity sensor **124** and the right hand of the user as a finite distance (indicating that the hand of the user grasping the handle is the right hand). On the other hand, if the optical proximity sensor **124** is embedded on the right hand side of the ring **112** and the hand of the user grasping the handle **104** is the left hand, the hand will not be in line of sight of the optical proximity sensor **124**. Therefore the light **128** will not reach the hand of the user and the light **128** from the optical proximity sensor **124** will not reflect back to the optical proximity sensor **124**, leading to a measurement of "infinite" distance (indicating that the hand of the user grasping the handle is the left hand).

[0048] In one embodiment, the optical proximity sensor **124** determines whether the hand of the user grasping the handle **104** is the right hand of the user or the left hand of the user based on whether a time interval between the optical proximity sensor **124** emitting light **128** in a direction of the hand of the user grasping the handle **104** and the optical proximity sensor **124** receiving reflected light from the hand of the user grasping the handle **104** is higher than a threshold time period. For example, if the optical proximity sensor **124** is embedded on the left hand side of the ring **112** (as shown in FIG. 1A), the hand of the user grasping the handle **104** is the left hand, and the optical proximity sensor **124** emits light **128** in a direction of the left hand of the user at time  $t_1$ , the light **128** may travel to the left hand and reflect back off the left hand towards the optical proximity sensor **124** and reach the optical proximity sensor at time  $t_2$ . The optical proximity sensor **124** may measure the time interval  $t_2-t_1$  as a finite time interval (indicating that the hand of the user grasping the handle is the left hand). On the other hand, if the optical proximity sensor **124** is embedded on the left hand side of the ring **112** (as shown in FIG. 1A) and the hand of the user grasping the handle **104** is the right hand, the hand will not be in line of sight of the optical proximity sensor **124**. Therefore the light **128** will not reach the right hand of the user and the light **128** from the optical proximity sensor **124** will not reflect back to the optical proximity sensor **124**, leading to a measurement of "infinite" time interval (indicating that the hand of the user grasping the handle is the right hand).

[0049] Similarly, if the optical proximity sensor **124** is embedded on the right hand side of the ring **112** (not shown in FIG. 1A), the hand of the user grasping the handle **104** is the right hand, and the optical proximity sensor **124** emits light **128** in a direction of the right hand of the user at time  $t_1$ , the light **128** may travel to the right hand and reflect back off the right hand towards the optical proximity sensor **124** and reach the optical proximity sensor at time  $t_2$ . The optical proximity sensor **124** may measure the time interval  $t_2-t_1$  as a finite time interval (indicating that the hand of the user grasping the handle is the right hand). On the other hand, if the optical proximity sensor **124** is embedded on the right

hand side of the ring **112** and the hand of the user grasping the handle **104** is the left hand, the hand will not be in line of sight of the optical proximity sensor **124**. Therefore the light **128** will not reach the left hand of the user and the light **128** from the optical proximity sensor **124** will not reflect back to the optical proximity sensor **124**, leading to a measurement of “infinite” time interval (indicating that the hand of the user grasping the handle is the left hand).

**[0050]** In this manner, the optical proximity sensor may enable the hand-held controller **100** to determine which hand of the user is grasping the handle **104**.

#### Example Cross Sectional View of a Ring of Hand-Held Controller

**[0051]** FIG. 1B is an example cross sectional view of the ring **112** of the hand-held controller **100** including the embedded optical proximity sensor **124**, in accordance with an embodiment. As described above with respect to FIG. 1A, in FIG. 1B the ring **112** has an annular surface **120** and a curved outer surface **116**. The optical proximity sensor **124** is embedded within the ring **112** to detect whether a hand of the user grasping the handle **104** is a right hand of the user or a left hand of the user.

**[0052]** The optical proximity sensor **124** may be embedded and positioned within the ring **112** in such a manner that the light **128** emitted by the optical proximity sensor **124** exits the ring **112** in a direction of a hand of the user grasping the handle **104**. In one embodiment, the light **128** emitted by the optical proximity sensor **124** is infrared light and at least part of the ring **112** is transparent to infrared light to allow the light **128** to exit the ring **112** in a direction of the hand of the user grasping the handle **104**. For example, the ring may be made of infrared transmitting plastic, infrared-transparent Poly(methyl methacrylate) (PMMA), also known as acrylic or acrylic glass, infrared-transparent polycarbonate, some other material transparent to infrared light, or a combination thereof. At least part of the light **128** emitted by the optical proximity sensor **124** exits through the curved outer surface **116** of the ring **112**.

**[0053]** A thickness **140** of the ring **112** between the optical proximity sensor **124** and the curved outer surface **116** may be designed to allow the light **128** to exit through the curved outer surface **116** of the ring **112**. For example, the thickness of the material of the ring **112** may be reduced where the material surrounds the optical proximity sensor **124**, such that it is easier for the light **128** emitted by the optical proximity sensor **124** to exit through the curved outer surface **116** of the ring **112**.

#### Example Schematic Perspective View of Hand-Held Controller Including Capacitive Electrode

**[0054]** FIG. 1C is an example schematic perspective view of a hand-held controller **100** including a capacitive electrode **132**, in accordance with an embodiment. As shown earlier in FIG. 1A, the hand-held controller **100** includes a handle **104** extending in a longitudinal direction **108**. A ring **112** is attached to an end of the handle **104** and has an annular surface **120** and a curved outer surface **116**.

**[0055]** The hand-held controller **100** includes a first capacitive electrode **132** mounted on a first side surface **136** of the handle as shown in FIG. 1C. The first capacitive electrode **132** uses capacitive sensing based on capacitive

coupling between the handle **104** and the hand of the user grasping the handle **104** to detect a first capacitance between the hand of the user and the handle **104**. The first capacitive electrode **132** may be made of copper, Indium tin oxide (ITO), printed ink, some other media, or a combination thereof. The size of the first capacitive electrode **132** and its spacing relative to the ground plane may be designed to improve the electrode’s performance in sensing the capacitance between the user’s hand and the handle **104**.

**[0056]** In one embodiment, the side surface **136** is coated with conductive material to form the first capacitive electrode **132**. In one embodiment, the first capacitive electrode **132** may be etched to form a grid pattern of electrodes. A voltage is applied to the first capacitive electrode **132**. When a conductor, such as a human finger or palm, touches the first capacitive electrode **132**, the capacitance between the finger or palm and the electrode is dynamically changed. The hand-held controller **100** can thus determine the capacitance using, in one embodiment, a sensor circuit coupled to the capacitive electrode, as described below with reference to FIG. 3B.

**[0057]** A second capacitive electrode (not shown in FIG. 1C) is mounted on a second side surface of the handle opposite to the first side surface **136**. The first capacitive electrode **132** and the second capacitive electrode detect whether the hand of the user grasping the handle **104** is a right hand of the user or a left hand of the user, as described in detail below with reference to FIG. 2C.

**[0058]** The handle **104** of the hand-held controller **100** includes a bottom surface **144**. If the hand of the user grasping the handle **104** is a right hand, the palm of the right hand will contact the second capacitive electrode (not shown in FIG. 1C). The fingers of the user will wrap around the bottom surface **144** of the handle **104** and contact the first capacitive electrode **132**. On the other hand, if the hand of the user grasping the handle **104** is a left hand, the palm of the left hand will contact the first capacitive electrode **132**. The fingers of the user will wrap around the bottom surface **144** of the handle **104** and contact the second capacitive electrode.

#### Example Schematic Side View of Hand-Held Controller Including Optical Proximity Sensor

**[0059]** FIG. 2A is an example schematic side view of a hand-held controller **100** including an optical proximity sensor **124**, in accordance with an embodiment. The annular surface **120** of the ring **112**, illustrated and described above with reference to FIG. 1A, defines a planar surface **224** that forms a predetermined angle **200** with respect to the longitudinal direction **108** in which the handle **104** extends. For example, the predetermined angle **200** may be between 45° to 135°. With the ring geometry illustrated in FIG. 2A, if the predetermined angle **200** is more than 45°, this avoids interference with the thumb movement of the user. If the predetermined angle **200** is less than 135°, this avoids any affects to the inside-out tracking visibility to a camera mounted on an HMD.

**[0060]** As described above with respect to FIG. 1A, in one embodiment, an optical proximity sensor **124** is embedded within the ring **112** to detect whether a hand of the user grasping the handle **104** is a right hand of the user or a left hand of the user. The optical proximity sensor **124** emits light **128** in a direction of the hand of the user grasping the handle **104** to sense the user’s hand.

Example Schematic Side View of Hand-Held Controller Including Optical Proximity Sensor

[0061] FIG. 2B is an example schematic side view of a hand-held controller 100 including an optical proximity sensor 124, in accordance with an embodiment. The annular surface 120 of the ring 112, illustrated and described above with reference to FIG. 1A, defines a planar surface 224 that forms a predetermined angle 200 with respect to the longitudinal direction 108 in which the handle 104 extends.

[0062] In one embodiment, an optical proximity sensor 124 is embedded within the handle 104 to detect whether a hand of the user grasping the handle 104 is a right hand of the user or a left hand of the user. The optical proximity sensor 124 emits light 128 in a direction of the hand of the user grasping the handle 104 to sense the user's hand.

[0063] The optical proximity sensor 124 determines whether the hand of the user grasping the handle 104 is the right hand of the user or the left hand of the user based on a distance between the hand and the optical proximity sensor 124. For example, if the optical proximity sensor 124 is embedded on the right hand side of the handle 104 (as shown in FIG. 2B) and the hand of the user grasping the handle 104 is the right hand, the optical proximity sensor 124 may measure the distance between the optical proximity sensor 124 and a portion of the right hand closer to the thumb (indicating that the hand is the right hand). On the other hand, if the hand of the user grasping the handle 104 is the left hand, the optical proximity sensor 124 may measure the distance between the optical proximity sensor 124 and a portion of the right hand closer to the little finger (indicating that the hand is the left hand). Similarly, distance measurements by the optical proximity sensor 124 placed on the opposite side surface (not shown in FIG. 2B) may indicate whether the hand gripping the handle 104 is a right hand or a left hand.

Example Schematic Side View of Hand-Held Controller Including Capacitive Electrode

[0064] FIG. 2C is an example schematic side view of a hand-held controller 100 including a first capacitive electrode 132, in accordance with an embodiment. As described above with respect to FIG. 2A, the annular surface 120 of the ring 112 defines a planar surface 224 that forms a predetermined angle 200 with respect to the longitudinal direction 108 in which the handle 104 extends. As described above with respect to FIG. 1C, the hand-held controller 100 includes a first capacitive electrode 132 mounted on a first side surface 136 of the handle 104. The first capacitive electrode 132 uses capacitive sensing based on capacitive coupling between the handle 104 and the hand of the user grasping the handle 104 to detect a first capacitance between the hand of the user and the handle 104.

[0065] A second capacitive electrode (not shown in FIG. 2C) is mounted on a second side surface of the handle opposite to the first side surface 136. The first capacitive electrode 132 and the second capacitive electrode detect whether the hand of the user grasping the handle 104 is a right hand of the user or a left hand of the user, as described in detail below with reference to FIG. 2D.

Example Schematic Planar View of Hand-Held Controller Including Capacitive Electrodes

[0066] FIG. 2D is an example schematic planar view of a hand-held controller 100 including capacitive electrodes 132

and 208, in accordance with an embodiment. The hand-held controller 100 includes a first capacitive electrode 132 mounted on a first side surface 136 of the handle 104 and a second capacitive electrode 208 mounted on a second side surface 204 of the handle 104 opposite to the first side surface 136. The first capacitive electrode 132 and the second capacitive electrode 208 detect whether the hand of the user grasping the handle 104 is a right hand of the user or a left hand of the user.

[0067] The first capacitive electrode 132 determines a first capacitance between the handle 104 and the hand of the user grasping the handle 104, as described above with respect to FIG. 1C. The second capacitive electrode 208 determines a second capacitance between the handle 104 and the hand of the user grasping the handle 104. For example, if the hand of the user grasping the handle 104 is a right hand, the palm of the right hand will contact the second capacitive electrode 208. The fingers of the user will wrap around a bottom surface 144 of the handle 104 and contact the first capacitive electrode 132. In this example, therefore, the first capacitance will be a capacitance between the handle 104 and a finger of the hand of the user grasping the handle 104. The second capacitance will be a capacitance between the handle 104 and a palm of the hand of the user grasping the handle 104. The first capacitance 132 will be less than the second capacitance because the user's fingers have less surface area than the user's palm. The hand-held controller 100 can thus determine that the hand of the user grasping the handle 104 is a right hand because the first capacitance 132 is less than the second capacitance.

[0068] On the other hand, if the hand of the user grasping the handle 104 is a left hand, the palm of the left hand will contact the first capacitive electrode 132. The fingers of the user will wrap around a bottom surface 144 of the handle 104 and contact the second capacitive electrode 208. In this example, therefore, the second capacitance will be a capacitance between the handle 104 and a finger of the hand of the user grasping the handle 104. The first capacitance will be a capacitance between the handle 104 and a palm of the hand of the user grasping the handle 104. The first capacitance 132 will be greater than the second capacitance because the user's fingers have less surface area than the user's palm. The hand-held controller 100 can thus determine that the hand of the user grasping the handle 104 is a left hand because the first capacitance 132 is greater than the second capacitance.

Example Schematic Block Diagram of Hand-Held Controller With Optical Proximity Sensor

[0069] FIG. 3A is an example schematic block diagram of a hand-held controller 100 including an optical proximity sensor 124, in accordance with an embodiment. The block diagram includes the optical proximity sensor 124, a sensor circuit 304, a wireless communication interface 312, and a bus 308. In alternative configurations, different and/or additional components may be included in the hand-held controller 100, such as a memory, central processing unit, battery, Bluetooth component, USB input, etc.

[0070] The optical proximity sensor 124 emits light 128 in a direction of a hand of a user grasping a handle (e.g., 104) of the hand-held controller 100. The optical proximity sensor 124 includes a photodiode or phototransistor to receive reflected light 324 from the hand of the user grasping the handle 104 to determine which hand of the user is



grasping the handle **104**, as described in detail above with respect to FIG. 2C. The optical proximity sensor **124** generates sensor signals **300** corresponding to the reflected light **324**. The sensor signals **300** indicate whether the hand of the user grasping the handle **104** is the right hand of the user or the left hand of the user.

[0071] The sensor circuit **304** is a digital, analog, or mixed-signal circuit to receive sensor signals **300** in the form of voltage or current from the optical proximity sensor **124**. Based on the sensor signals **300**, the sensor circuit **304** may determine which hand of the user is grasping the handle **104**. The hand-held controller **100** may include a circuit to provide electrical signals, such as voltage, to the sensor circuit **304** and the optical proximity sensor **124**. The sensor circuit **304** may be powered by a battery on the hand-held controller **100** to generate the electrical signals. The optical proximity sensor **124** may emit the light **128** responsive to receiving the electrical signals.

[0072] The hand-held controller **100** also includes the wireless communication interface **312**, which may be a digital, analog, or mixed-signal circuit, to transmit wireless signals **316** indicating whether the hand of the user grasping the handle **104** is a right hand of the user or a left hand of the user. The wireless signals **316** may be transmitted to a head-mounted display, a computer, an artificial reality system, etc. The wireless communication interface **312** may send and receive data via a wireless network without the need for connecting cables to the hand-held controller **100**. In one embodiment, the wireless communication interface **312** may support the USB 1.1 and 802.11b wireless network standards up to 11 Mbps data transfer rates. In one embodiment, the wireless communication interface **312** may support the USB 2.0 and 802.11g standards up to 54 Mbps data transfer rates. In one embodiment, the wireless communication interface **312** may be a Compact Flash (CF) wireless network adapter using infrared technology for data exchanges between the hand-held controller **100** and a computer, etc. The wireless communication interface **312** and the sensor circuit **304** may communicate via the bus **308**.

#### Example Schematic Block Diagram of Hand-Held Controller With Capacitive Electrodes

[0073] FIG. 3B is an example schematic block diagram of a hand-held controller **100** including capacitive electrodes **132** and **208**, in accordance with an embodiment. The block diagram includes the first capacitive electrode **132**, the second capacitive electrode **208**, a sensor circuit **304**, and a wireless communication interface **312**. In alternative configurations, different and/or additional components may be included in the hand-held controller **100**, such as a memory, central processing unit, battery, Bluetooth component, USB input, etc.

[0074] The first capacitive electrode **132** generates first sensor signals **328** corresponding to a first capacitance between the handle **104** and the hand of the user grasping the handle **104**. For example, the first capacitive electrode **132** may be in an inactive state when the intended conductive object (hand of the user) is not nearby. The first capacitive electrode **132** may be in an active state when the intended conductive object (hand of the user) is within the desired activation range. The sensor signals **328**, generated by the first capacitive electrode **132**, may be a function of current or voltage vs time. For example, a distinct rise in the sensor signals **328** waveform measured by the sensor circuit **304**

may indicate the presence of the user's hand touching or near the first capacitive electrode **132**.

[0075] Similarly, the second capacitive electrode **208** generates second sensor signals **332** corresponding to a second capacitance between the handle **104** and the hand of the user grasping the handle **104**.

[0076] The sensor circuit **308** is coupled to the first capacitive electrode **132** and the second capacitive electrode **208** to receive the first sensor signals **328** from the first capacitive electrode **132** and receive the second sensor signals **332** from the second capacitive electrode **208**. The sensor circuit **308** determines whether the hand of the user grasping the handle **104** is the right hand of the user or the left hand of the user based on whether the first sensor signals **328** are stronger than the second sensor signals **332**. For example if a voltage value of the first sensor signals **328** is higher than a voltage value of the second sensor signals **332**, it may indicate that the hand of the user grasping the handle **104** is the right hand. In another example, the sensor circuit **308** may determine that a difference between the first sensor signals **328** and the second sensor signals **332** is higher than a threshold value, indicating a change in parametric state crossed by the first sensor signals **328** and the second sensor signals **332**. The change in parametric state may indicate that the hand of the user grasping the handle **104** is the right hand.

[0077] In one embodiment, the sensor circuit **304** determines whether the hand of the user grasping the handle **104** is the right hand of the user or the left hand of the user based on whether the first capacitance is higher than the second capacitance. This may be implemented, for example, if the capacitive electrodes include circuitry to determine which part (palm or fingers) of the user is touching the electrodes based on the measured capacitances and inform the sensor circuit **304** accordingly. For example, if the first capacitance is higher than the second capacitance, it may indicate that the hand of the user grasping the handle **104** is the right hand.

[0078] The hand-held controller **100** may include a circuit to provide electrical signals, such as voltage, to the first capacitive electrode **132**, the second capacitive electrode **208**, and the sensor circuit **304**. The sensor circuit **304** may be powered by a battery on the hand-held controller **100** to generate the electrical signals.

[0079] As described above with respect to FIG. 3A, the hand-held controller **100** may include a wireless communication interface **312** to transmit wireless signals **316** indicating whether the hand of the user grasping the handle **104** is a right hand of the user or a left hand of the user.

#### Example Process to Determine Which Hand of the User is Grasping a Controller

[0080] FIG. 4 is a flowchart illustrating an example process for determining whether a hand of a user grasping a hand-held controller is a right hand of the user or a left hand of the user, in accordance with an embodiment.

[0081] A first capacitive electrode **132**, mounted on a first side surface **136** of a handle **104** of a hand-held controller **100**, determines **400** a first capacitance between the handle **104** and a hand of the user grasping the handle **104**, as described above with reference to FIGS. 1C, 2B, 2C, and 3B.

[0082] A second capacitive electrode **208**, mounted on a second side surface **204** of the handle **104**, determines **410**

a second capacitance between the handle **104** and the hand of the user grasping the handle **104**, as described above with reference to FIGS. 1C, 2B, 2C, and 3B.

**[0083]** The hand-held controller **100** determines **420** whether the hand of the user grasping the handle **104** is the right hand of the user or the left hand of the user based on whether the first capacitance is higher than the second capacitance. For example, the first capacitive electrode **132** may generate first sensor signals **328** corresponding to the first capacitance. The second capacitive electrode **208** may generate second sensor signals **332** corresponding to the second capacitance. The determining of whether the hand of the user grasping the handle **104** is the right hand of the user or the left hand of the user may include determining whether the first sensor signals **328** are stronger than the second sensor signals **332**. For example if a voltage value of the first sensor signals **328** is higher than a voltage value of the second sensor signals **332**, it may indicate that the hand of the user grasping the handle **104** is the right hand.

**[0084]** The foregoing description of the embodiments has been presented for the purpose of illustration; it is not intended to be exhaustive or to limit the embodiments to the precise forms disclosed. Persons skilled in the relevant art can appreciate that many modifications and variations are possible in light of the above disclosure.

**[0085]** Finally, the language used in the specification has been principally selected for readability and instructional purposes, and it may not have been selected to delineate or circumscribe the inventive subject matter. It is therefore intended that the scope be limited not by this detailed description, but rather by any claims that issue on an application based hereon. Accordingly, the disclosure of the embodiments is intended to be illustrative, but not limiting, of the scope, which is set forth in the following claims.

What is claimed is:

1. A hand-held controller, comprising:
  - a handle extending in a longitudinal direction, the handle shaped and dimensioned to be grasped by a hand of a user;
  - a ring attached to an end of the handle and having:
    - an annular surface defining a plane that forms a pre-determined angle with respect to the longitudinal direction, and
    - a curved outer surface; and
  - an optical proximity sensor embedded within the ring or the handle and configured to detect whether the hand of the user grasping the handle is a right hand of the user or a left hand of the user.
2. The hand-held controller of claim 1, wherein the optical proximity sensor is configured to emit light in a direction of the hand of the user grasping the handle.
3. The hand-held controller of claim 3, wherein the light is infrared light.
4. The hand-held controller of claim 1, wherein the optical proximity sensor comprises a photodiode or phototransistor configured to receive reflected light from the hand of the user grasping the handle and generate sensor signals corresponding to the reflected light, the sensor signals indicating whether the hand of the user grasping the handle is the right hand of the user or the left hand of the user.
5. The hand-held controller of claim 1, wherein the optical proximity sensor is configured to determine whether the hand of the user grasping the handle is the right hand of the user or the left hand of the user based on whether a time

interval between the optical proximity sensor emitting light in a direction of the hand of the user grasping the handle and the optical proximity sensor receiving reflected light from the hand of the user grasping the handle is higher than a threshold time period.

6. The hand-held controller of claim 1, wherein at least part of the ring or the handle is transparent to infrared light.

7. The hand-held controller of claim 1, wherein at least part of the light emitted by the optical proximity sensor exits through the curved outer surface of the ring or a side surface of the handle.

8. A hand-held controller, comprising:

- a handle extending in a longitudinal direction, the handle shaped and dimensioned to be grasped by a hand of a user;

- a ring attached to an end of the handle and having:

- an annular surface defining a plane that forms a pre-determined angle with respect to the longitudinal direction, and

- a curved outer surface; and

- a first capacitive electrode mounted on a first side surface of the handle and a second capacitive electrode mounted on a second side surface of the handle opposite to the first side surface, the first capacitive electrode and the second capacitive electrode configured to detect whether the hand of the user grasping the handle is a right hand of the user or a left hand of the user.

9. The hand-held controller of claim 8, wherein the first capacitive electrode and the second capacitive electrode are further configured to be contacted by the hand of the user grasping the handle.

10. The hand-held controller of claim 8, wherein:

- the first capacitive electrode is further configured to determine a first capacitance between the handle and the hand of the user grasping the handle; and

- the second capacitive electrode is further configured to determine a second capacitance between the handle and the hand of the user grasping the handle.

11. The hand-held controller of claim 8, wherein:

- the first capacitive electrode is further configured to generate first sensor signals corresponding to a first capacitance between the handle and the hand of the user grasping the handle; and

- the second capacitive electrode is further configured to generate second sensor signals corresponding to a second capacitance between the handle and the hand of the user grasping the handle.

12. The hand-held controller of claim 11, wherein

- the first capacitance is a capacitance between the handle and a finger of the hand of the user grasping the handle; and

- the second capacitance is a capacitance between the handle and a palm of the hand of the user grasping the handle.

13. The hand-held controller of claim 11, further comprising a sensor circuit coupled to the first capacitive electrode and the second capacitive electrode, the sensor circuit configured to:

- receive the first sensor signals from the first capacitive electrode;

- receive the second sensor signals from the second capacitive electrode; and

- determine whether the hand of the user grasping the handle is the right hand of the user or the left hand of

the user based on whether the first sensor signals are stronger than the second sensor signals.

**14.** The hand-held controller of claim **11**, further comprising a sensor circuit coupled to the first capacitive electrode and the second capacitive electrode, the sensor circuit configured to determine whether the hand of the user grasping the handle is the right hand of the user or the left hand of the user based on whether the first capacitance is higher than the second capacitance.

**15.** The hand-held controller of claim **8**, further comprising a wireless communication interface configured to transmit wireless signals indicating whether the hand of the user grasping the handle is a right hand of the user or a left hand of the user.

**16.** A method, comprising:

determining, by a first capacitive electrode mounted on a first side surface of a handle of a hand-held controller, a first capacitance between the handle and a hand of the user grasping the handle;

determining, by a second capacitive electrode mounted on a second side surface of the handle, a second capacitance between the handle and the hand of the user grasping the handle; and

determining whether the hand of the user grasping the handle is the right hand of the user or the left hand of the user based on whether the first capacitance is higher than the second capacitance.

**17.** The method of claim **16**, further comprising:

generating, by the first capacitive electrode, first sensor signals corresponding to the first capacitance; and

generating, by the second capacitive electrode, second sensor signals corresponding to the second capacitance.

**18.** The method of claim **17**, wherein the determining of whether the hand of the user grasping the handle is the right hand of the user or the left hand of the user comprises determining whether the first sensor signals are stronger than the second sensor signals.

**19.** The method of claim **16**, wherein the first capacitance is a capacitance between the handle and a finger of the hand of the user grasping the handle.

**20.** The method of claim **16**, wherein the second capacitance is a capacitance between the handle and a palm of the hand of the user grasping the handle.

\* \* \* \* \*