



(19) **United States**

(12) **Patent Application Publication**

McNamara et al.

(10) **Pub. No.: US 2020/0091717 A1**

(43) **Pub. Date: Mar. 19, 2020**

(54) **PROVIDING COMPUTATIONAL RESOURCE AVAILABILITY BASED ON POWER-GENERATION SIGNALS**

(52) **U.S. Cl.**
CPC *H02J 3/14* (2013.01); *G05B 15/02* (2013.01); *G05F 1/66* (2013.01); *H02J 3/18* (2013.01)

(71) Applicant: **Lancium LLC**, Houston, TX (US)

(57) **ABSTRACT**

(72) Inventors: **Michael T. McNamara**, Newport Beach, CA (US); **David J. Henson**, Houston, TX (US); **Raymond E. Cline, JR.**, Houston, TX (US)

Example embodiments for providing computation resource availability based on power-generation signals are presented herein. An embodiment may involve receive information indicative of power-generation economic signals at a first control system and identifying at least one of: (i) a change in a power-generation economic signal that exceeds a predefined threshold change, (ii) a power-generation economic signal that is below a predefined lower threshold limit, or (iii) a power-generation economic signal that is above a predefined upper threshold limit. Responsive to the identification, the embodiment involves performing at least one of: (i) adjusting a rate of power use by a flexible datacenter, and (ii) providing an indication of computation resource availability to a second control system. The flexible datacenter may include a behind-the-meter power input system, a power distribution system, and computing systems configured to receive power from the behind-the-meter power input system via the power distribution system.

(21) Appl. No.: **16/132,098**

(22) Filed: **Sep. 14, 2018**

Publication Classification

(51) **Int. Cl.**
H02J 3/14 (2006.01)
H02J 3/18 (2006.01)
G05F 1/66 (2006.01)
G05B 15/02 (2006.01)

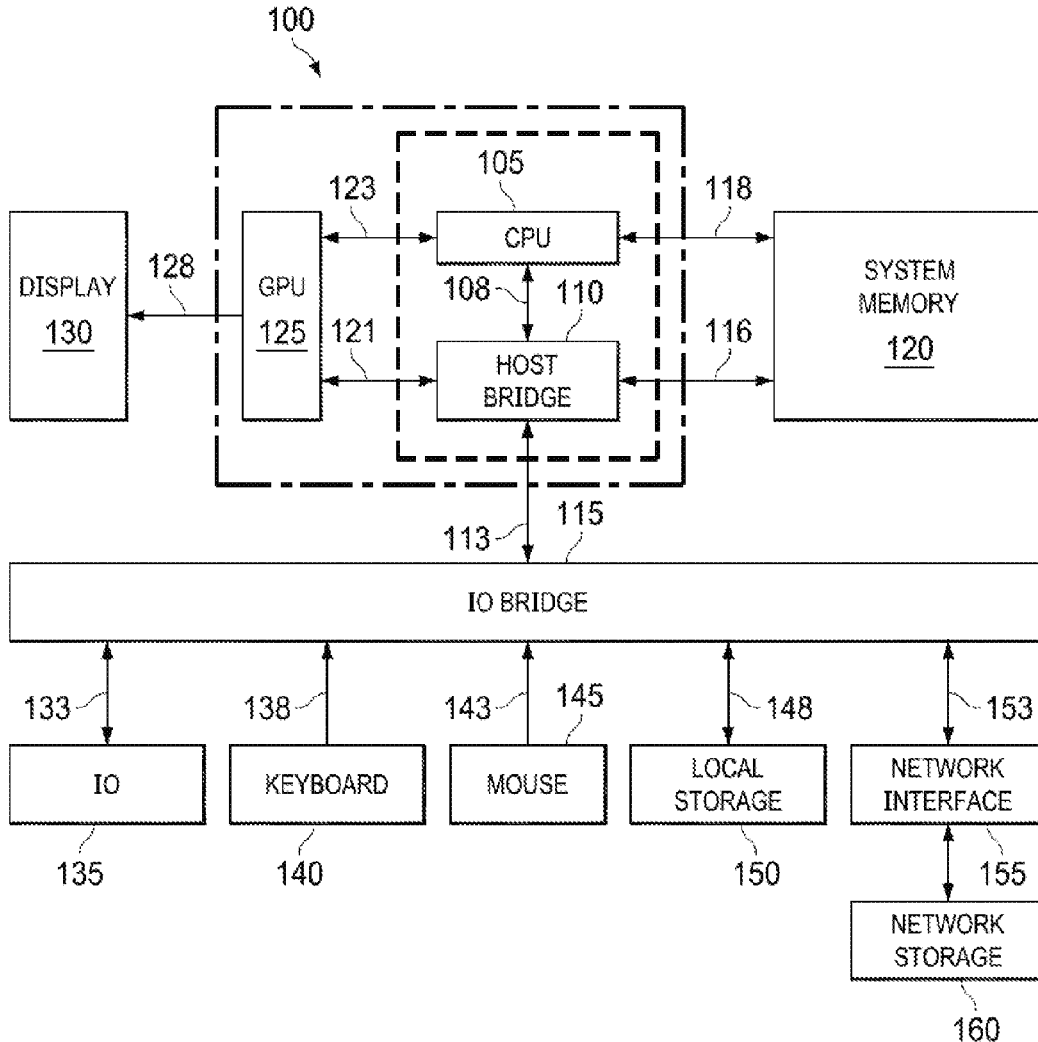

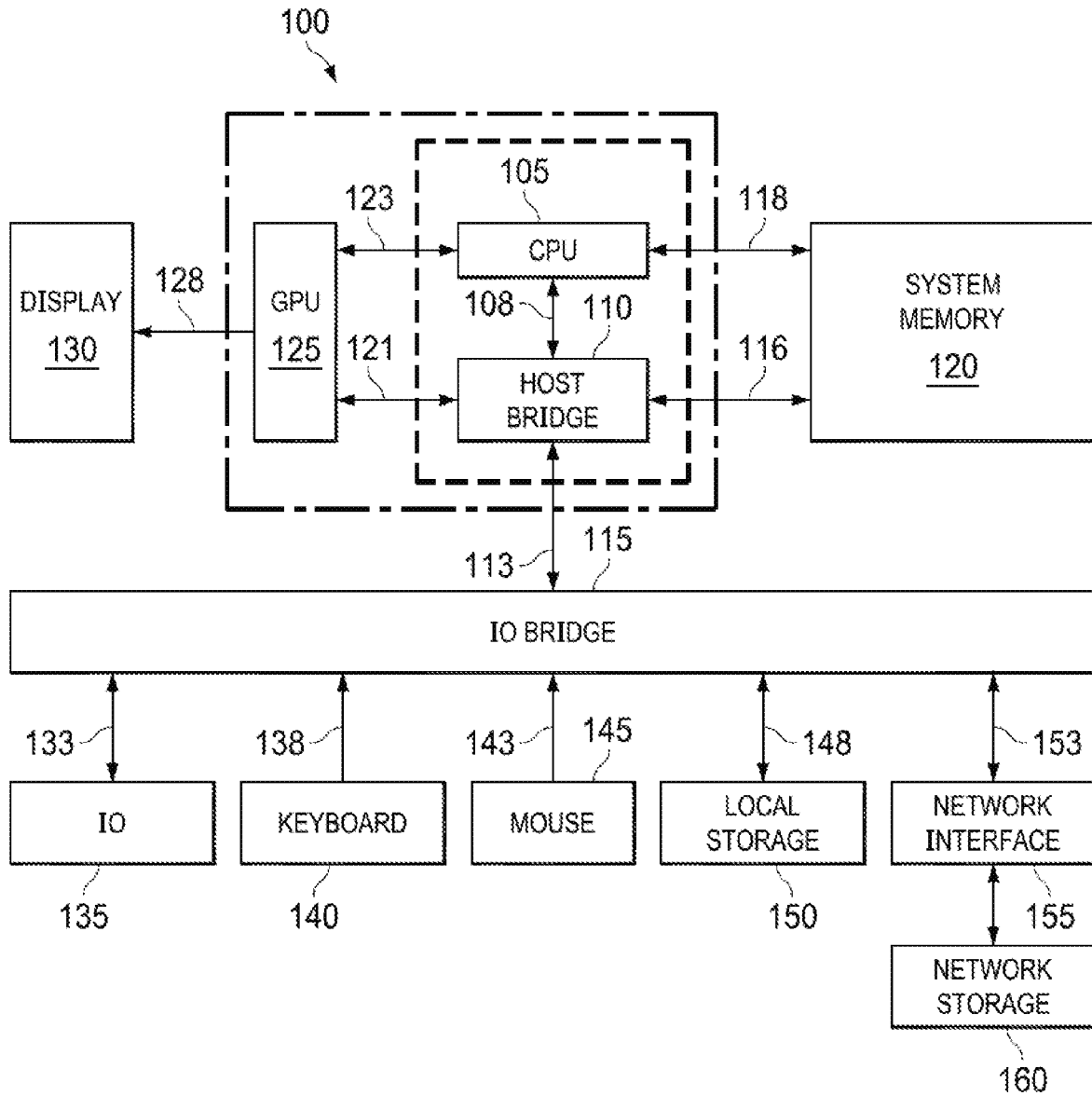

FIG. 1

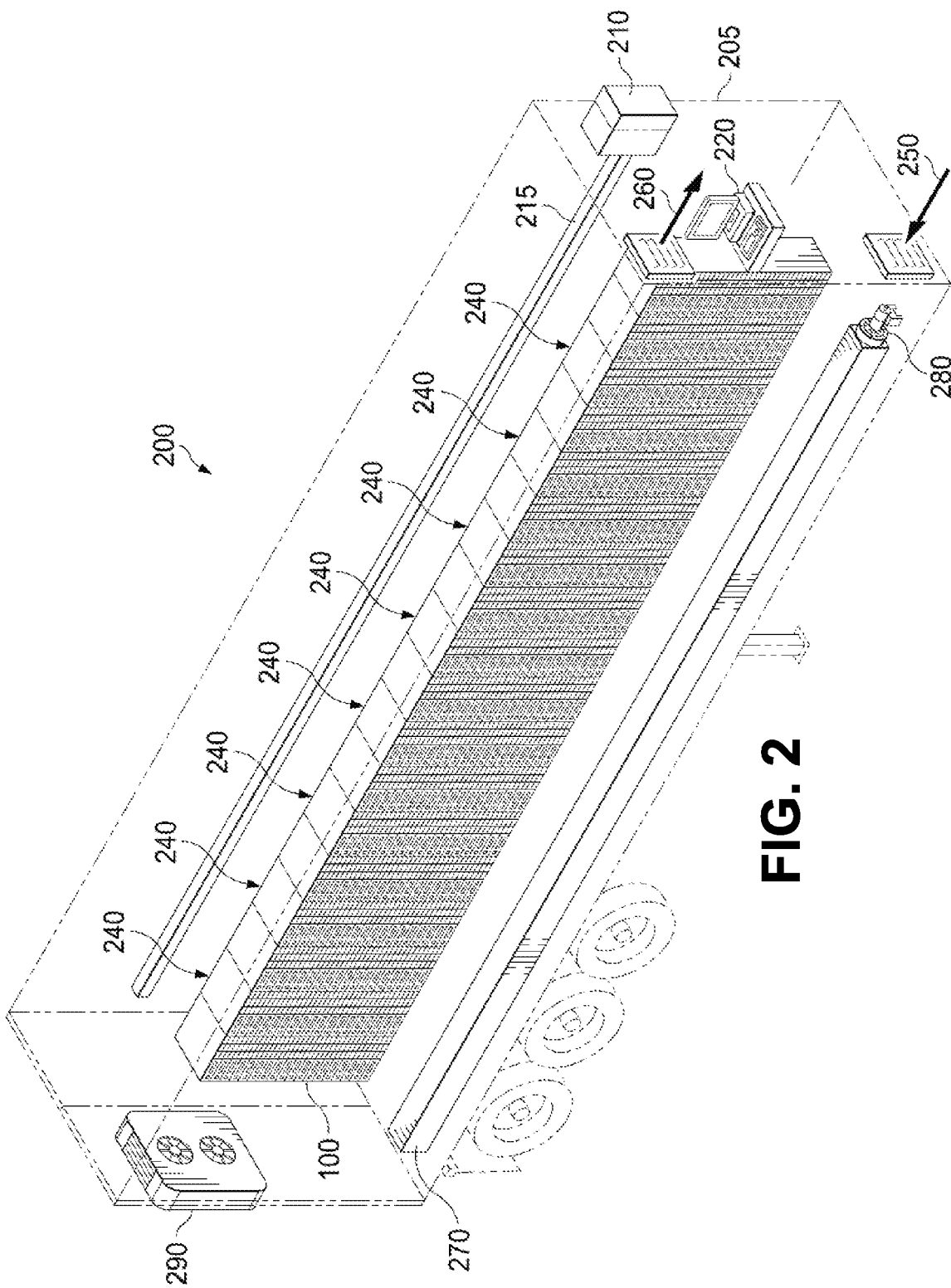

FIG. 2

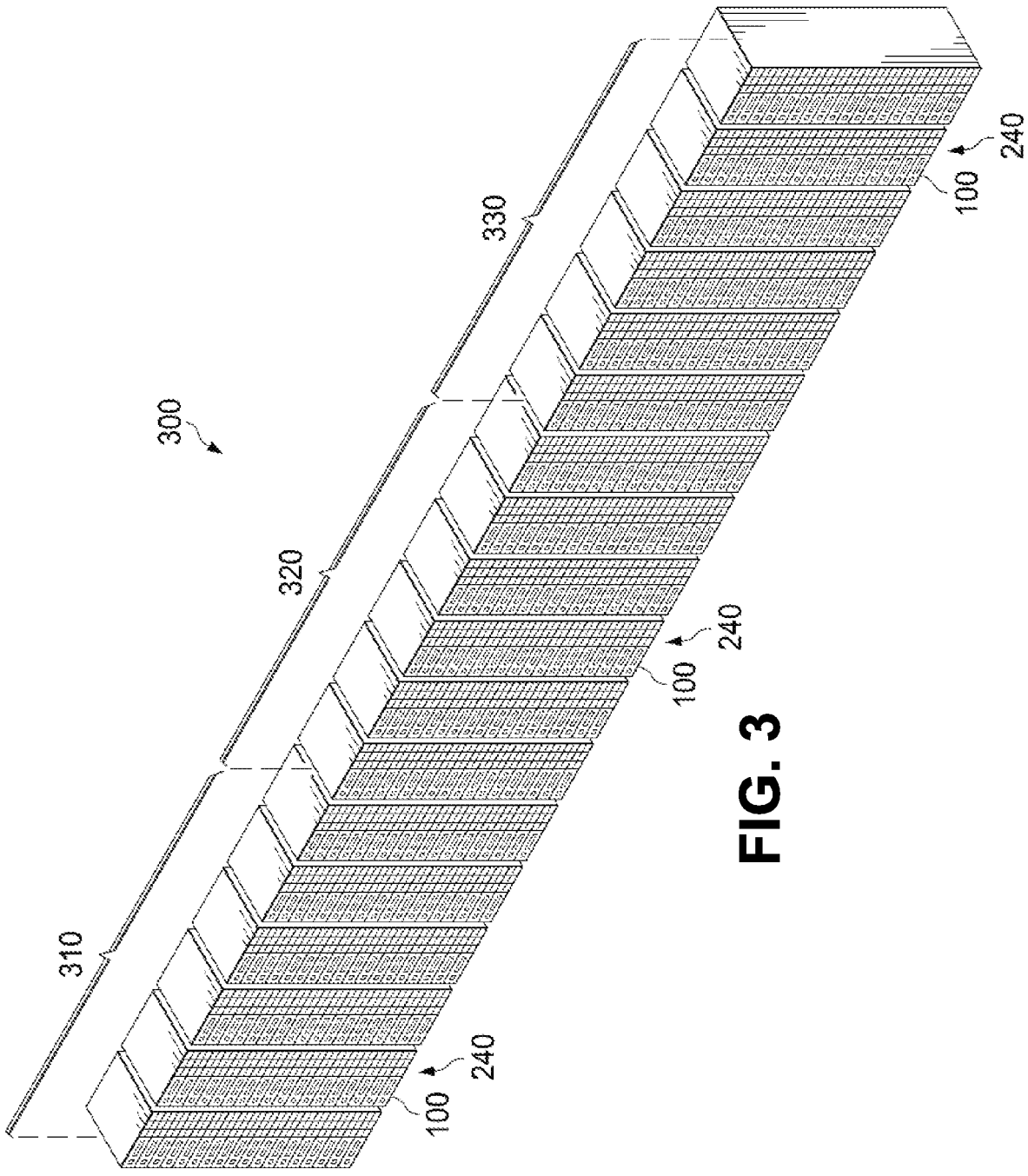

FIG. 3

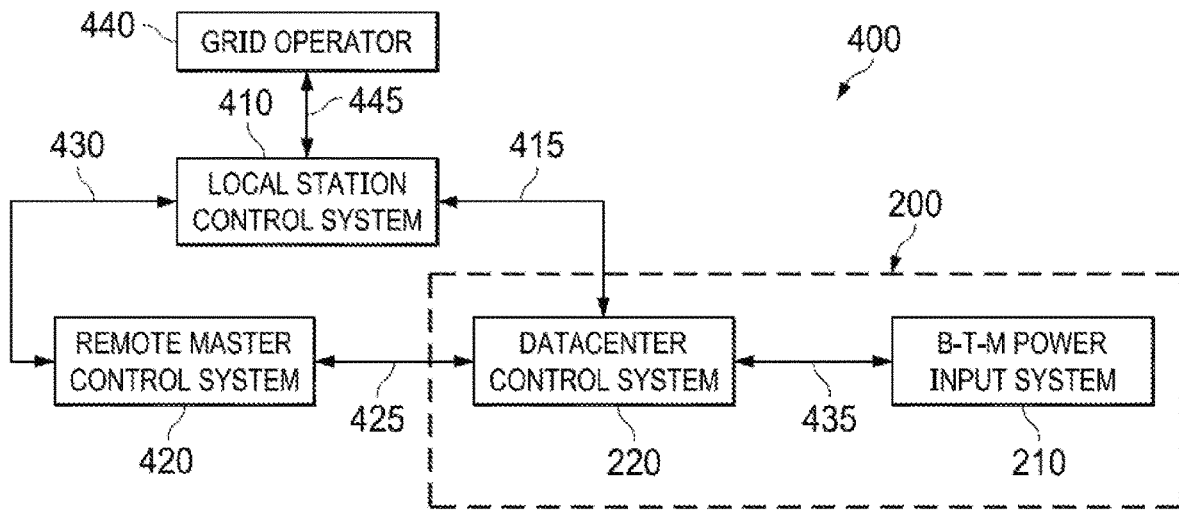

FIG. 4

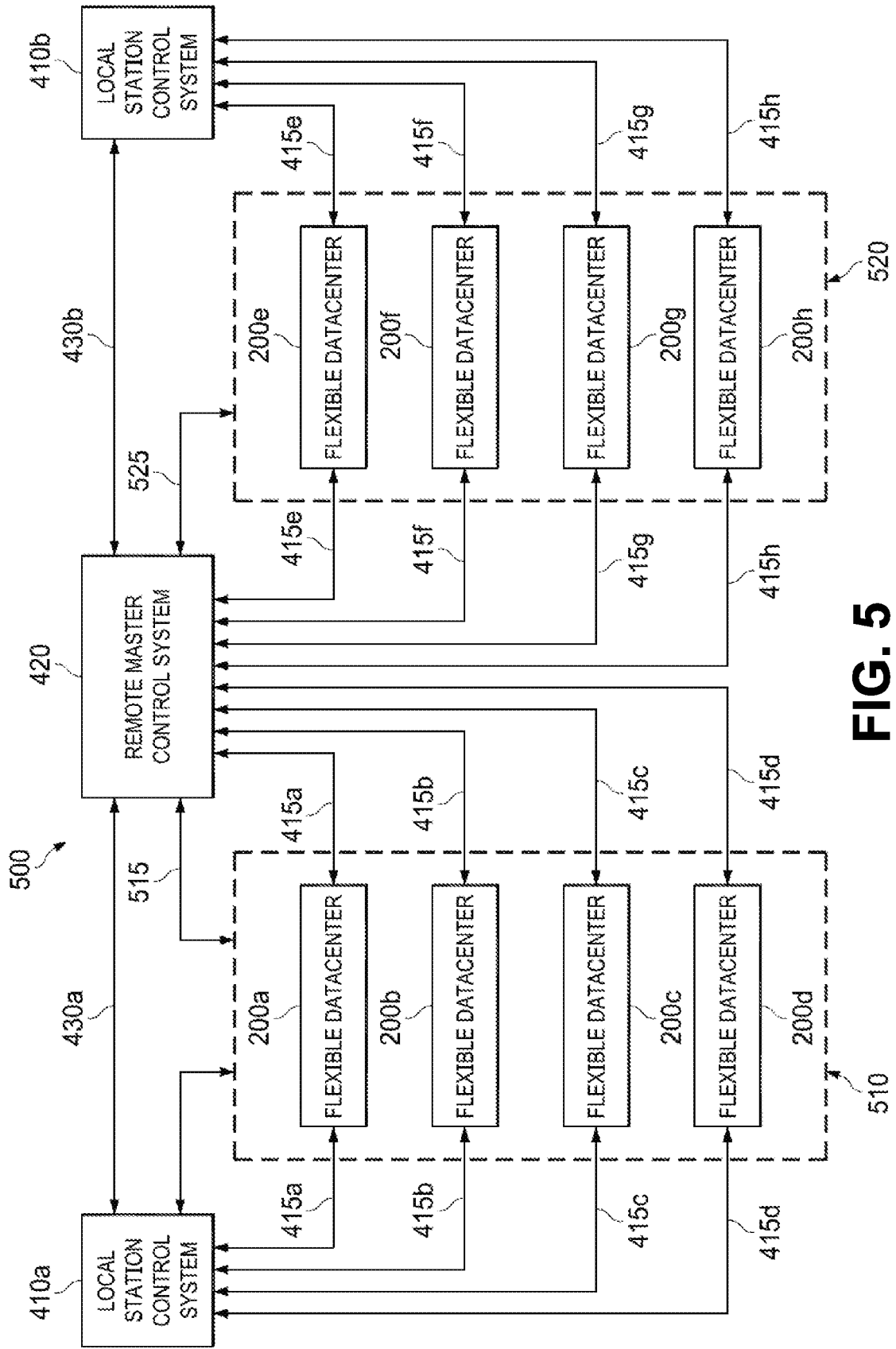

FIG. 5

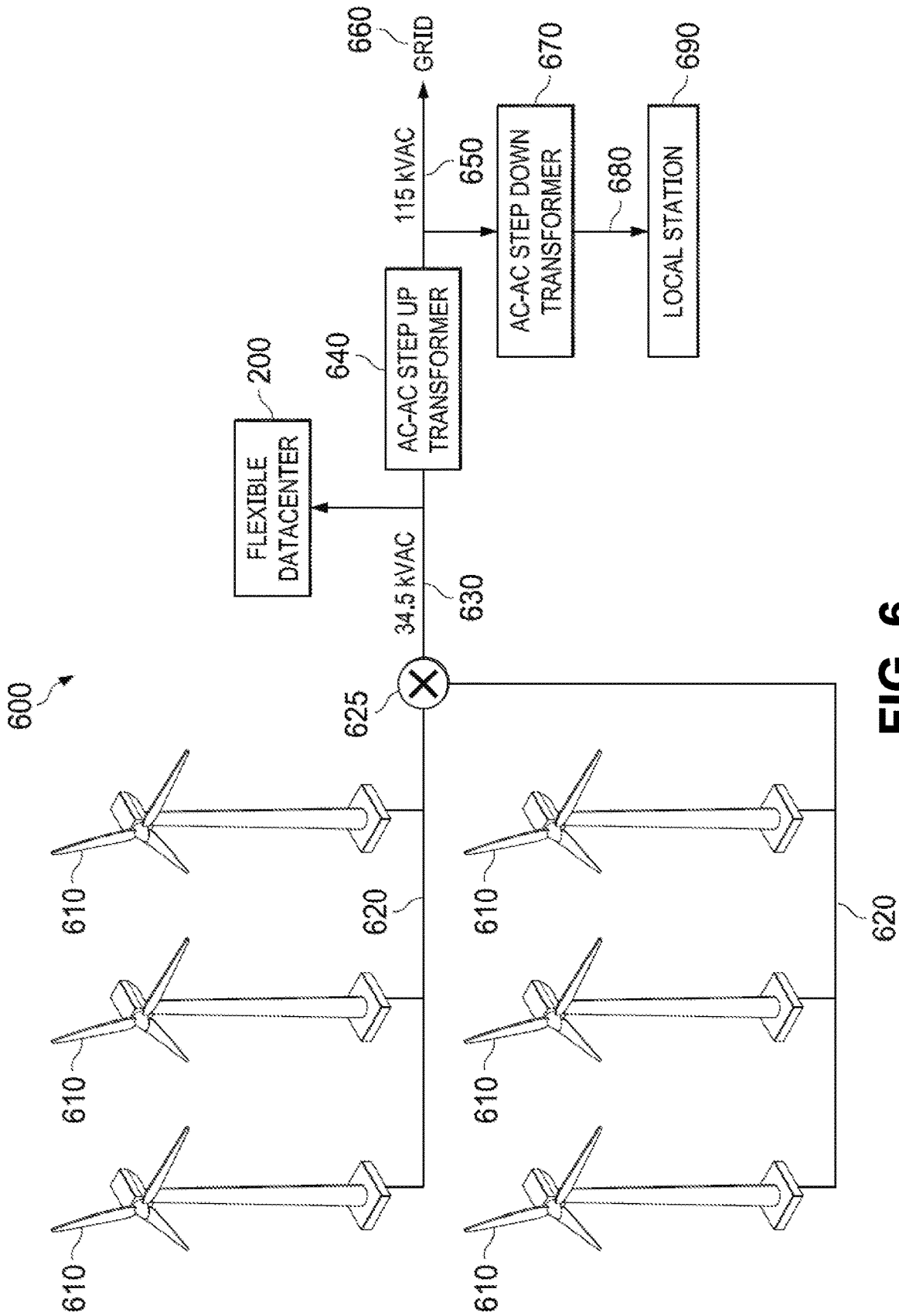

FIG. 6

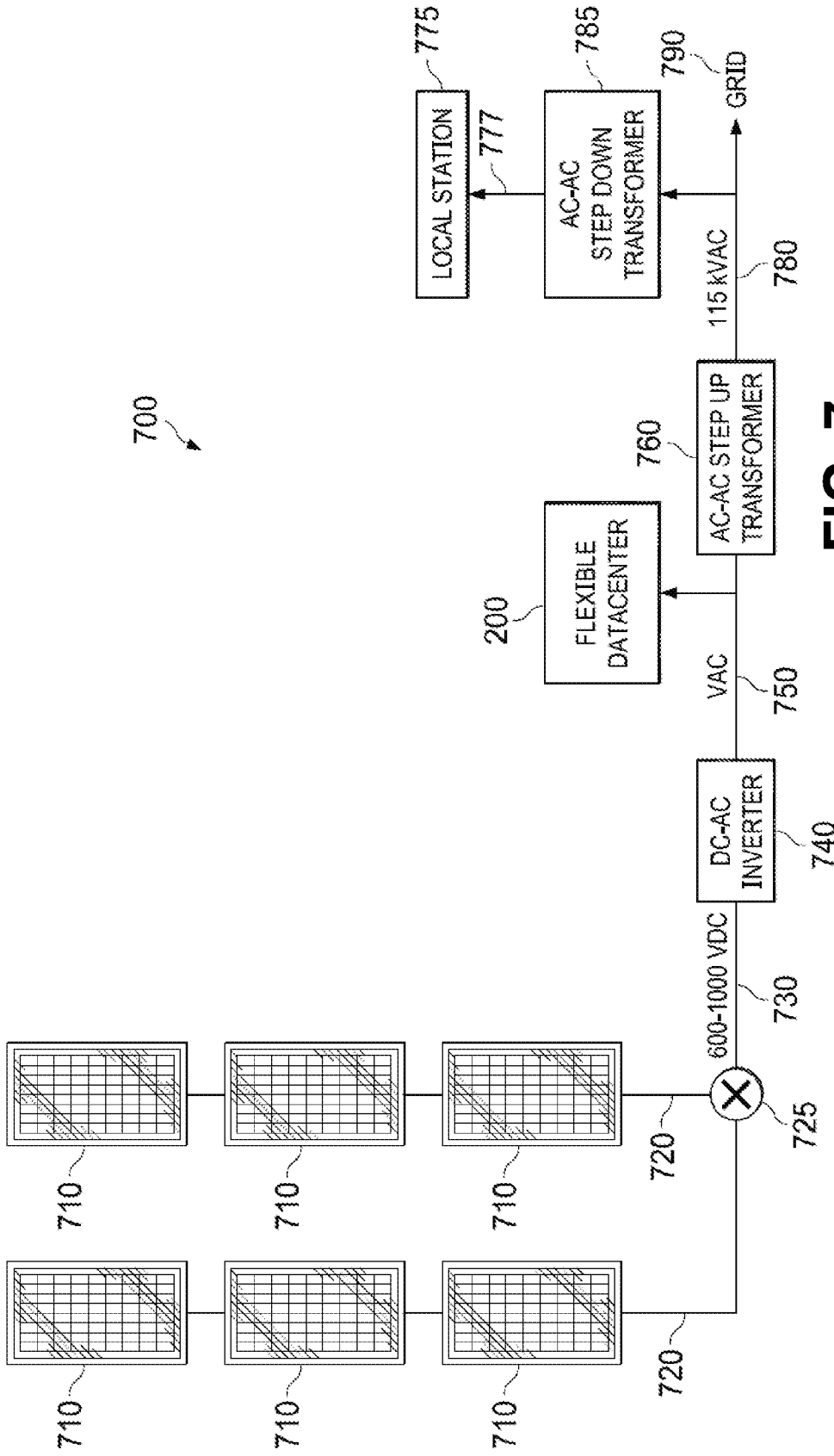

FIG. 7

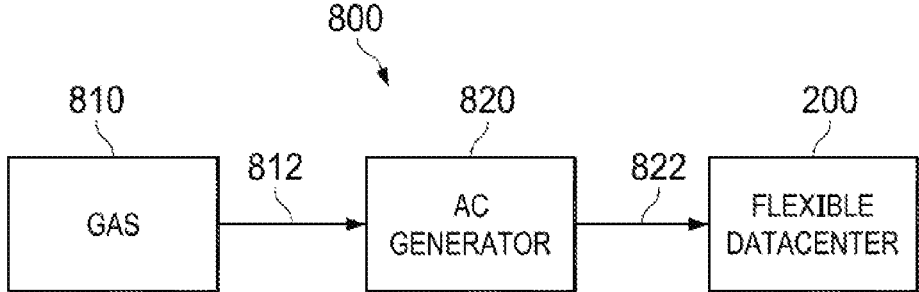

FIG. 8

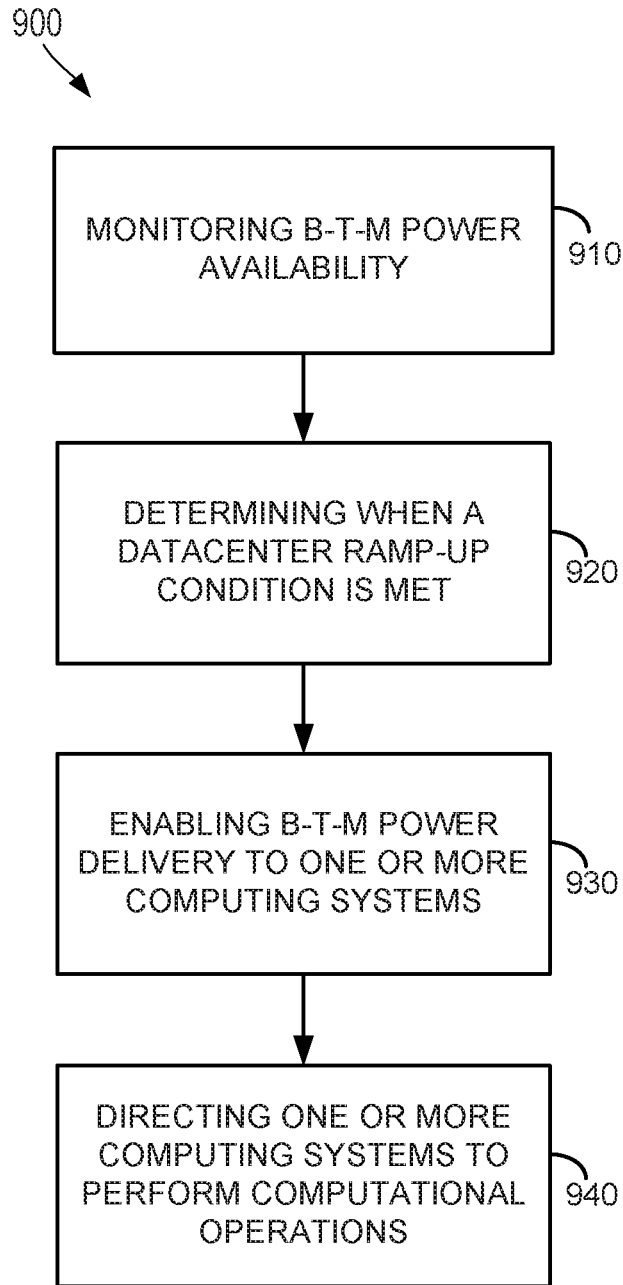

FIG. 9A

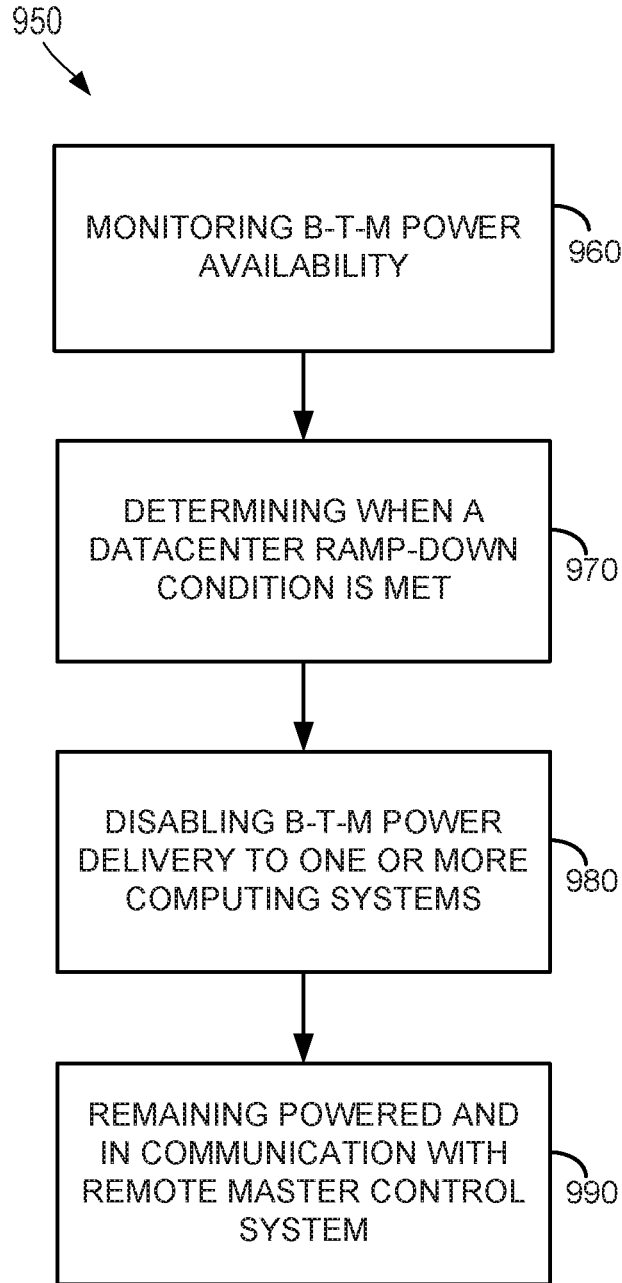

FIG. 9B

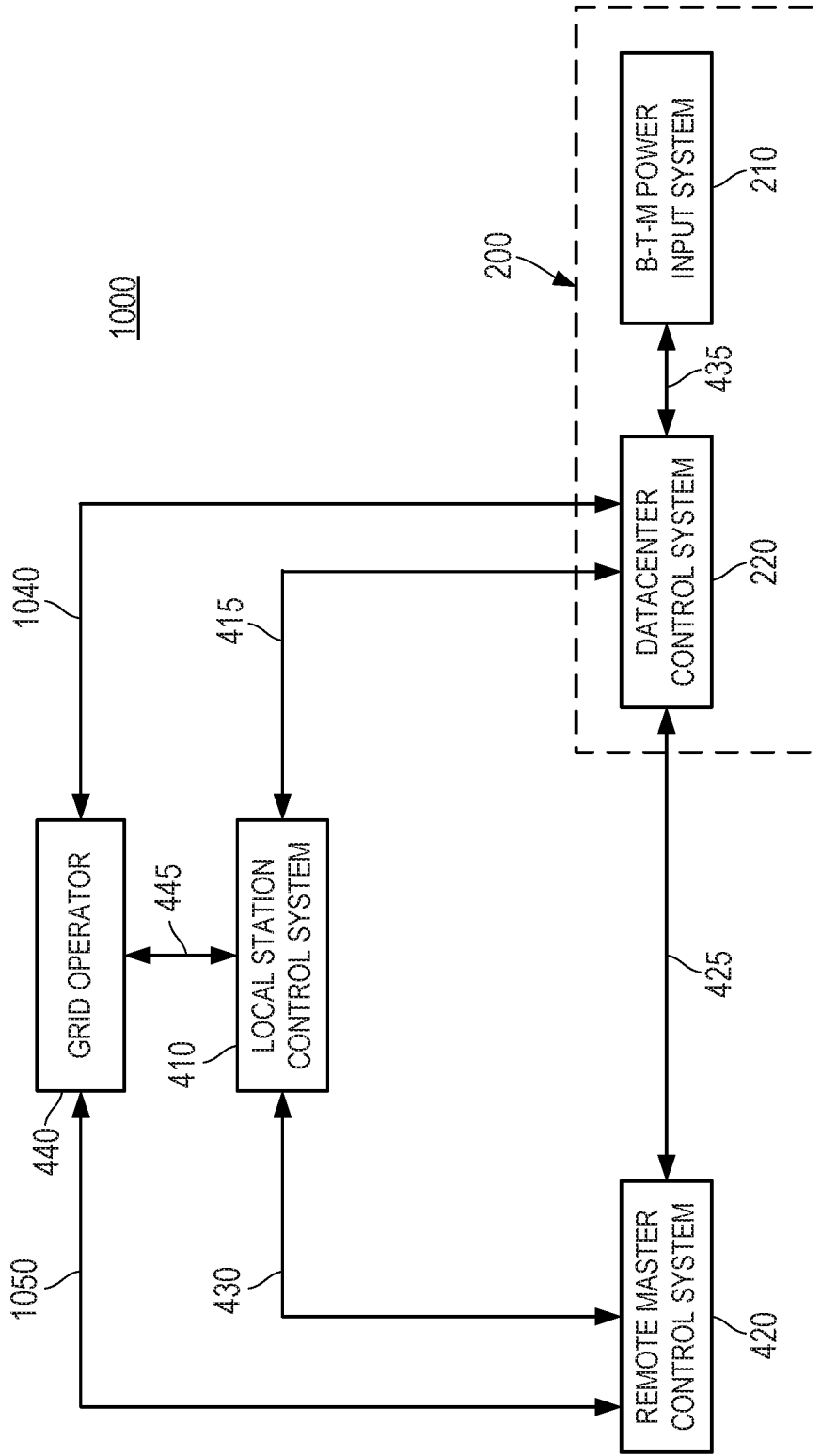

FIG. 10

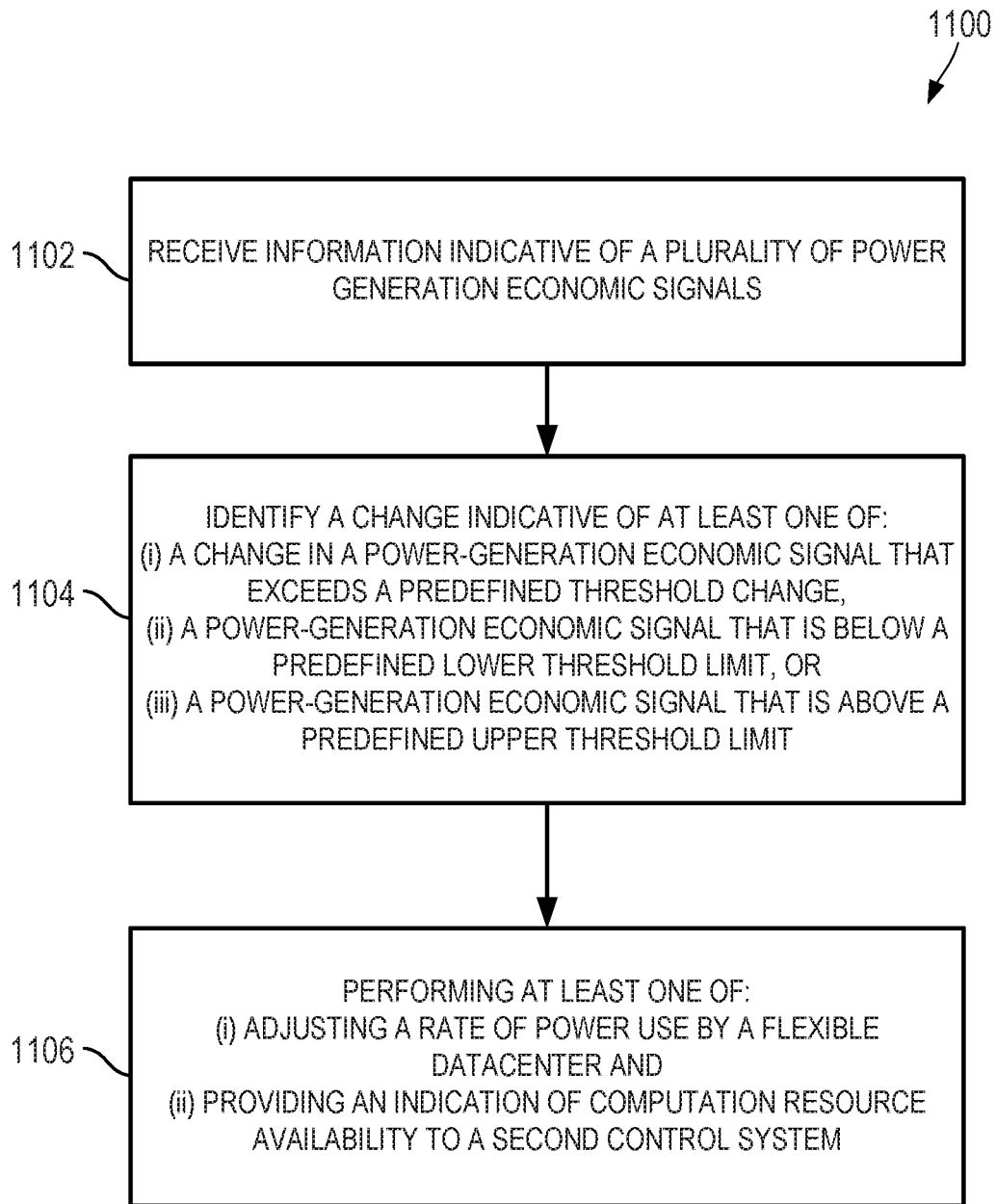

FIG. 11

**PROVIDING COMPUTATIONAL RESOURCE
AVAILABILITY BASED ON
POWER-GENERATION SIGNALS**

FIELD OF THE INVENTION

[0001] This specification relates to a system for controlling the use of “behind-the-meter” power.

BACKGROUND OF THE INVENTION

[0002] The price for power distributed through regional and national electric power grids is composed of Generation, Administration, and Transmission & Distribution (“T&D”) costs. T&D costs are a significant portion of the overall price paid by consumers for electricity. T&D costs include capital costs (land, equipment, substations, wire, etc.), electrical transmission losses, and operation and maintenance costs. Electrical power is typically generated at local stations (e.g., coal, natural gas, nuclear, and renewable sources) in the Medium Voltage class of 2.4 kVAC to 69 kVAC before being converted in an AC-AC step up transformer to High Voltage at 115 kVAC or above. T&D costs are accrued at the point the generated power leaves the local station and is converted to High Voltage electricity for transmission onto the grid.

[0003] Local station operators are paid a variable market price for the amount of power leaving the local station and entering the grid. However, grid stability requires that a balance exist between the amount of power entering the grid and the amount of power used from the grid. Grid stability and congestion is the responsibility of the grid operator and grid operators take steps, including curtailment, to reduce power supply from local stations when necessary. Frequently, the market price paid for generated power will be decreased in order to disincentivize local stations from generating power. In some cases, the market price will go negative, resulting in a cost to local station operators who continue to supply power onto a grid. Grid operators may sometimes explicitly direct a local station operator to reduce or stop the amount of power the local station is supplying to the grid.

[0004] Power market fluctuations, power system conditions such as power factor fluctuation or local station startup and testing, and operational directives resulting in reduced or discontinued generation all can have disparate effects on renewal energy generators and can occur multiple times in a day and last for indeterminate periods of time. Curtailment, in particular, is particularly problematic.

[0005] According to the National Renewable Energy Laboratory’s Technical Report TP-6A20-60983 (March 2014):

[0006] [C]urtailment [is] a reduction in the output of a generator from what it could otherwise produce given available resources (e.g., wind or sunlight), typically on an involuntary basis. Curtailments can result when operators or utilities command wind and solar generators to reduce output to minimize transmission congestion or otherwise manage the system or achieve the optimal mix of resources. Curtailment of wind and solar resources typically occurs because of transmission congestion or lack of transmission access, but it can also occur for reasons such as excess generation during low load periods that could cause base-load generators to reach minimum generation thresholds, because of voltage or interconnection issues, or to maintain frequency requirements, particularly for small, isolated

grids. Curtailment is one among many tools to maintain system energy balance, which can also include grid capacity, hydropower and thermal generation, demand response, storage, and institutional changes. Deciding which method to use is primarily a matter of economics and operational practice.

[0007] “Curtailment” today does not necessarily mean what it did in the early 2000s. Two sea changes in the electric sector have shaped curtailment practices since that time: the utility-scale deployment of wind power, which has no fuel cost, and the evolution of wholesale power markets. These simultaneous changes have led to new operational challenges but have also expanded the array of market-based tools for addressing them.

[0008] Practices vary significantly by region and market design. In places with centrally-organized wholesale power markets and experience with wind power, manual wind energy curtailment processes are increasingly being replaced by transparent offer-based market mechanisms that base dispatch on economics. Market protocols that dispatch generation based on economics can also result in renewable energy plants generating less than what they could potentially produce with available wind or sunlight. This is often referred to by grid operators by other terms, such as “downward dispatch.” In places served primarily by vertically integrated utilities, power purchase agreements (PPAs) between the utility and the wind developer increasingly contain financial provisions for curtailment contingencies.

[0009] Some reductions in output are determined by how a wind operator values dispatch versus non-dispatch. Other curtailments of wind are determined by the grid operator in response to potential reliability events. Still other curtailments result from overdevelopment of wind power in transmission-constrained areas.

[0010] Dispatch below maximum output (curtailment) can be more of an issue for wind and solar generators than it is for fossil generation units because of differences in their cost structures. The economics of wind and solar generation depend on the ability to generate electricity whenever there is sufficient sunlight or wind to power their facilities.

[0011] Because wind and solar generators have substantial capital costs but no fuel costs (i.e., minimal variable costs), maximizing output improves their ability to recover capital costs. In contrast, fossil generators have higher variable costs, such as fuel costs. Avoiding these costs can, depending on the economics of a specific generator, to some degree reduce the financial impact of curtailment, especially if the generator’s capital costs are included in a utility’s rate base.

[0012] Curtailment may result in available energy being wasted (which may not be true to the same extent for fossil generation units which can simply reduce the amount of fuel that is being used). With wind generation, in particular, it may also take some time for a wind farm to become fully operational following curtailment. As such, until the time that the wind farm is fully operational, the wind farm may not be operating with optimum efficiency and/or may not be able to provide power to the grid.

BRIEF SUMMARY OF THE INVENTION

[0013] In an example, a method is described. The method may involve receiving, at a first control system, information indicative of a plurality of power-generation economic signals, and, based on the received information, identifying, by the first control system, at least one of: (i) a change indica-

tive of a power-generation economic signal that exceeds a predefined threshold change, (ii) a power-generation economic signal that is below a predefined lower threshold limit, or (iii) a power-generation economic signal that is above a predefined upper threshold limit. The method may involve, based on the identification, performing at least one of: (i) adjusting a rate of power use by a flexible datacenter and (ii) providing an indication of computation resource availability to a second control system. The flexible datacenter may comprise a behind-the-meter power input system, a power distribution system, and a plurality of computing systems configured to receive power from the behind-the-meter power input system via the power distribution system.

[0014] In another example, a system is described. The system may comprise a flexible datacenter comprising: a behind-the-meter power input system, a power distribution system, and a plurality of computing systems configured to receive power from the behind-the-meter power input system via the power distribution system. The system may further comprise a first control system configured to: receive information indicative of a plurality of power-generation economic signals, and based on the received information, identify at least one of: (i) a change indicative of a power-generation economic signal that exceeds a predefined threshold change, (ii) a power-generation economic signal that is below a predefined lower threshold limit, or (iii) a power-generation economic signal that is above a predefined upper threshold limit. The first control system may be configured to, based on the identification, perform at least one of: (i) adjusting a rate of power use by a flexible datacenter, and (ii) providing an indication of computation resource availability to a second control system.

[0015] In a further example, a non-transitory computer readable medium having stored thereon instructions, that when executed by one or more processors, cause a control system to perform functions. The functions may comprise receiving information indicative of a plurality of power-generation economic signals and, based on the received information, identifying at least one of: (i) a change indicative of a power-generation economic signal that exceeds a predefined threshold change, (ii) a power-generation economic signal that is below a predefined lower threshold limit, or (iii) a power-generation economic signal that is above a predefined upper threshold limit. The functions may further comprise, based on the identification, performing at least one of: (i) adjusting a rate of power use by a flexible datacenter, and (ii) providing an indication of computation resource availability to a second control system. The flexible datacenter may comprise a behind-the-meter power input system, a power distribution system, and a plurality of computing systems configured to receive power from the behind-the-meter power input system via the power distribution system.

[0016] Other aspects of the present invention will be apparent from the following description and claims.

BRIEF DESCRIPTION OF THE DRAWINGS

[0017] FIG. 1 shows a computing system in accordance with one or more embodiments of the present invention.

[0018] FIG. 2 shows a flexible datacenter in accordance with one or more embodiments of the present invention.

[0019] FIG. 3 shows a three-phase power distribution of a flexible datacenter in accordance with one or more embodiments of the present invention.

[0020] FIG. 4 shows a control distribution scheme of a flexible datacenter in accordance with one or more embodiments of the present invention.

[0021] FIG. 5 shows a control distribution scheme of a fleet of flexible datacenters in accordance with one or more embodiments of the present invention.

[0022] FIG. 6 shows a flexible datacenter powered by one or more wind turbines in accordance with one or more embodiments of the present invention.

[0023] FIG. 7 shows a flexible datacenter powered by one or more solar panels in accordance with one or more embodiments of the present invention.

[0024] FIG. 8 shows a flexible datacenter powered by flare gas in accordance with one or more embodiments of the present invention.

[0025] FIG. 9A shows a method of dynamic power delivery to a flexible datacenter using behind-the-meter power in accordance with one or more embodiments of the present invention.

[0026] FIG. 9B shows another method of dynamic power delivery to a flexible datacenter using behind-the-meter power in accordance with one or more embodiments of the present invention.

[0027] FIG. 10 shows a system for managing available computational resources based on power-generation economics in accordance with one or more embodiments of the present invention.

[0028] FIG. 11 shows a method for managing available computational resources based on power-generation economics in accordance with one or more embodiments of the present invention.

DETAILED DESCRIPTION OF THE INVENTION

[0029] One or more embodiments of the present invention are described in detail with reference to the accompanying figures. For consistency, like elements in the various figures are denoted by like reference numerals. In the following detailed description of the present invention, specific details are set forth in order to provide a thorough understanding of the present invention. In other instances, well-known features to one having ordinary skill in the art are not described to avoid obscuring the description of the present invention.

[0030] The embodiments provided herein relate to providing an electrical load “behind the meter” at local stations such that generated power can be directed to the behind-the-meter load instead of onto the grid, typically for intermittent periods of time. “Behind-the-meter” power includes power that is received from a power generation system (for instance, but not limited to, a wind or solar power generation system) prior to the power undergoing step-up transformation to High Voltage class AC power for transmission to the grid. Behind-the-meter power may therefore include power drawn directly from an intermittent grid-scale power generation system (e.g. a wind farm or a solar array) and not from the grid.

[0031] The embodiments herein provide an advantage when, for example, the power system conditions exhibit excess local power generation at a local station level, excess local power generation that a grid cannot receive, local power generation that is subject to economic curtailment,

local power generation that is subject to reliability curtailment, local power generation that is subject to power factor correction, low local power generation, start up local power generation situations, transient local power generation situations, conditions where the cost for power is economically viable (e.g., low cost for power), or testing local power generation situations where there is an economic advantage to using local behind-the-meter power generation. This is not least because the excess power can be utilized by the behind-the-meter electrical load rather than going to waste. In addition, by providing an electrical load behind-the-meter rather than connected to the grid, electrical transmission losses resulting from transmission of power through the grid can be reduced. In addition, any degradation in the power generation systems which may result from curtailment may be reduced.

[0032] Preferably, controlled computing systems that consume electrical power through computational operations can provide a behind-the-meter electrical load that can be granularly ramped up and down quickly under the supervision of control systems that monitor power system conditions and direct the power state and/or computational activity of the computing systems. In one embodiment, the computing systems preferably receive all their power for computational operations from a behind-the-meter power source. In another embodiment, the computing systems may additionally include a connection to grid power for supervisory and communication systems or other ancillary needs. In yet another embodiment, the computing systems can be configured to switch between behind-the-meter power and grid power under the direction of a control system.

[0033] Among other benefits, a computing system load with controlled granular ramping allows a local station to avoid negative power market pricing and to respond quickly to grid directives.

[0034] Various computing systems can provide granular behind-the-meter ramping. Preferably the computing systems perform computational tasks that are immune to, or not substantially hindered by, frequent interruptions or slowdowns in processing as the computing systems ramp up and down. In one embodiment, control systems can activate or de-activate one or more computing systems in an array of similar or identical computing systems sited behind the meter. For example, one or more blockchain miners, or groups of blockchain miners, in an array may be turned on or off. In another embodiment, control systems can direct time-insensitive computational tasks to computational hardware, such as CPUs and GPU, sited behind the meter, while other hardware is sited in front of the meter and possibly remote from the behind-the-meter hardware. Any parallel computing processes, such as Monte Carlo simulations, batch processing of financial transactions, graphics rendering, and oil and gas field simulation models are all good candidates for such interruptible computational operations.

[0035] To enable cost efficient use of available power and computational resources, a control system may be configured to manage computational availability based on power-generation economics. Particularly, the control system may receive information indicative of power-generation economic signals. A power-generation economic signal may provide information that can be used when managing computational resources. The information included within each power-generation economic signal may depend on the source providing the information. For example, a power-

generation economic signal may be based on a cost of power received from a power grid. As the power grid supplies a datacenter (e.g., a flexible datacenter) with power, the cost of the power can change over time based on various factors, such as the time of day, the demand for the power, and the availability of the power. The control system or another computing system may be configured to measure power-generation economic signals.

[0036] A power-generation economic signal may similarly be based on a cost of power received from a B-T-M power source. In some embodiments, a control system may use one or more power-generation economic signals that are based on a comparison of a price for power grid power relative to a price for behind-the-meter power. The comparison may enable the control system to determine when utilizing behind-the-meter to power computational resources is advantageous.

[0037] Power-generation economic signals may also be based on a purchase price associated with supplying power to computing systems within a flexible datacenter. Particularly, the control system may control or assist with the control of the computing systems within the flexible datacenter, including modulating the power supplied to the computing systems. As such, the control system may utilize power-generation economic signals that provide information about the purchase price for power associated with supplying the flexible datacenter to determine whether to ramp up or ramp down power supplied to flexible datacenter.

[0038] In addition, the control system may also use information within power-generation economic signals to determine whether to switch the power source that the flexible datacenter is receiving power from. For example, the control system may switch the flexible datacenter from a first B-T-M power source to a second B-T-M power source based on changes in purchase prices for power indicated within power-generation economic signals. Thus, when managing computational resources (e.g., a flexible datacenter), the control system may utilize information provided within power-generation economic signals.

[0039] As indicated above, a control system may obtain power-generation economic signals to manage available computational resources. Using information within one or more power-generation economic signals, the control system may identify a change in a power-generation economic signal that exceeds a predefined threshold change. A change in a power-generation economic signal that undergoes the predefined threshold change may trigger the control system to perform an action in response, such as adjusting a rate of power use by one or more flexible datacenters or providing an indication of computational resource availability in light of the threshold change. For example, a sudden drop in the purchase price of B-T-M power may result in the control system ramping up the power supplied to one or more flexible datacenters or ramping up the number of computing systems within a flexible datacenter receiving power. Other threshold changes represented in power-generation economic signals might cause the control system to perform other actions in response, such as ramping down power supplied to a flexible datacenter or providing an indication of the change to consumers using the available computational resources.

[0040] The control system may also use information within one or more power-generation economic signals to identify a power-generation economic signal that is below a

predefined lower threshold limit or above a predefined upper threshold limit. The lower and upper threshold limits may be predefined to enable the control system to monitor when to make changes to the availability of computational resources. For example, when the cost of power received from the power grid drops below a predefined lower threshold price, the control system may increase the reliance or consumption of power from the power grid by available computational resources to capitalize on the price decrease. Similarly, the control system may decrease the reliance or consumption of power from the power grid by computational resources when the cost of power from the power grid exceeds the upper threshold price.

[0041] A similar set up with upper and lower threshold prices may be set up for managing power consumption from B-T-M power sources as well. In some examples, the control system may switch the computing systems of one or more flexible datacenters between grid power and a B-T-M power source based on changes in prices represented within power-generation economic signals. Additionally, the control system may also switch computing systems of one or more flexible datacenters between different B-T-M power sources based on price changes and power availability indicated within power-generation economic signals.

[0042] The control system may use information identified within power-generation economic signals to perform actions, such as adjusting a rate of power used by computing resources (e.g., a flexible datacenter) and providing an indication of computation resource availability to other computing devices (e.g., another control system). The power-generation economic signals can help the control system dynamically increase or decrease the rate of power used by available computation resources. For example, when B-T-M power is available at a purchase price that is less than the price a customer is willing to spend on a task, the control system may cause computing resources within one or more flexible datacenters to use the B-T-M power to perform the task for the customer. The control system may use the variety of information provided within power-generation economic signals to efficiently power and manage available computing resources, including determining when to switch between available power sources, when to ramp up or ramp down the power supplied, and when to adjust the quantity of computing systems performing a task, etc. This way, the control system may accommodate customers' price expectations through measuring and comparing the availability and prices associated with receiving power from different power sources.

[0043] Within examples, the control system may represent a computing system capable of receiving and processing power-generation economic signals. In some embodiments, the control system may correspond to a datacenter control system that is collocated with a flexible datacenter. As such, the datacenter control system may be configured to receive power from a power grid and one or more B-T-M power sources. In other embodiments, the control system may be a remote master control system located remote from a flexible datacenter. As such, the remote master control system may communicate with a datacenter control system that is collocated with the flexible datacenter. The communication may enable the remote master control system to remotely adjust the rate of power used by the flexible datacenter or to provide indications of power supplies available or computation resource availability to the datacenter control center.

[0044] In some cases, the local station may generate more power than can be consumed by the computing systems or distributed to the grid, or the computing systems may need to continue computational operations for a limited period of time beyond when a ramp-down condition is met. Accordingly, in one or more embodiments of the present invention, methods and systems for dynamic power delivery to a flexible datacenter that uses behind-the-meter power sources that includes both generated power and stored behind-the-meter power, each without transmission and distribution costs. A flexible datacenter may be configured to modulate power delivery to at least a portion of the computing systems based on monitored power system conditions or an operational directive. For example, the flexible datacenter may ramp-up to a full capacity status, ramp-down to an off capacity status, or dynamically reduce power consumption, act a load balancer, or adjust the power factor. Each of these activities may be performed using any or all of behind-the-meter generated power, behind-the-meter stored power, and/or grid power. Advantageously, the flexible datacenter may perform computational operations, such as blockchain hashing operations or simulations, with little to no energy costs, using clean and renewable energy that would otherwise be wasted.

[0045] FIG. 1 shows a computing system 100 in accordance with one or more embodiments of the present invention. Computing system 100 may include one or more central processing units (singular "CPU" or plural "CPUs") 105, host bridge 110, input/output ("IO") bridge 115, graphics processing units (singular "GPU" or plural "GPUs") 125, and/or application-specific integrated circuits (singular "ASIC" or plural "ASICs") (not shown) disposed on one or more printed circuit boards (not shown) that are configured to perform computational operations. Each of the one or more CPUs 105, CPUs 125, or ASICs (not shown) may be a single-core (not independently illustrated) device or a multi-core (not independently illustrated) device. Multi-core devices typically include a plurality of cores (not shown) disposed on the same physical die (not shown) or a plurality of cores (not shown) disposed on multiple die (not shown) that are collectively disposed within the same mechanical package (not shown).

[0046] CPU 105 may be a general purpose computational device typically configured to execute software instructions. CPU 105 may include an interface 108 to host bridge 110, an interface 118 to system memory 120, and an interface 123 to one or more IO devices, such as, for example, one or more GPUs 125. GPU 125 may serve as a specialized computational device typically configured to perform graphics functions related to frame buffer manipulation. However, one of ordinary skill in the art will recognize that GPU 125 may be used to perform non-graphics related functions that are computationally intensive. In certain embodiments, GPU 125 may interface 123 directly with CPU 125 (and interface 118 with system memory 120 through CPU 105). In other embodiments, GPU 125 may interface 121 with host bridge 110 (and interface 116 or 118 with system memory 120 through host bridge 110 or CPU 105 depending on the application or design). In still other embodiments, GPU 125 may interface 133 with IO bridge 115 (and interface 116 or 118 with system memory 120 through host bridge 110 or CPU 105 depending on the application or design). The functionality of GPU 125 may be integrated, in whole or in part, with CPU 105.

[0047] Host bridge 110 may be an interface device configured to interface between the one or more computational devices and IO bridge 115 and, in some embodiments, system memory 120. Host bridge 110 may include an interface 108 to CPU 105, an interface 113 to IO bridge 115, for embodiments where CPU 105 does not include an interface 118 to system memory 120, an interface 116 to system memory 120, and for embodiments where CPU 105 does not include an integrated GPU 125 or an interface 123 to GPU 125, an interface 121 to GPU 125. The functionality of host bridge 110 may be integrated, in whole or in part, with CPU 105, IO bridge 115 may be an interface device configured to interface between the one or more computational devices and various IO devices (e.g., 140, 145) and IO expansion, or add-on, devices (not independently illustrated). IO bridge 115 may include an interface 113 to host bridge 110, one or more interfaces 133 to one or more IO expansion devices 135, an interface 138 to keyboard 140, an interface 143 to mouse 145, an interface 148 to one or more local storage devices 150, and an interface 153 to one or more network interface devices 155. The functionality of IO bridge 115 may be integrated, in whole or in part, with CPU 105 or host bridge 110. Each local storage device 150, if any, may be a solid-state memory device, a solid-state memory device array, a hard disk drive, a hard disk drive array, or any other non-transitory computer readable medium. Network interface device 155 may provide one or more network interfaces including any network protocol suitable to facilitate networked communications.

[0048] Computing system 100 may include one or more network-attached storage devices 160 in addition to, or instead of, one or more local storage devices 150. Each network-attached storage device 160, if any, may be a solid-state memory device, a solid-state memory device array, a hard disk drive, a hard disk drive array, or any other non-transitory computer readable medium. Network-attached storage device 160 may or may not be collocated with computing system 100 and may be accessible to computing system 100 via one or more network interfaces provided by one or more network interface devices 155.

[0049] One of ordinary skill in the art will recognize that computing system 100 may be a conventional computing system or an application-specific computing system. In certain embodiments, an application-specific computing system may include one or more ASICs (not shown) that are configured to perform one or more functions, such as hashing, in a more efficient manner. The one or more ASICs (not shown) may interface directly with CPU 105, host bridge 110, or GPU 125 or interface through IO bridge 115. Alternatively, in other embodiments, an application-specific computing system may be reduced to only those components necessary to perform a desired function in an effort to reduce one or more of chip count, printed circuit board footprint, thermal design power, and power consumption. The one or more ASICs (not shown) may be used instead of one or more of CPU 105, host bridge 110, IO bridge 115, or GPU 125. In such systems, the one or more ASICs may incorporate sufficient functionality to perform certain network and computational functions in a minimal footprint with substantially fewer component devices.

[0050] As such, one of ordinary skill in the art will recognize that CPU 105, host bridge 110, IO bridge 115, GPU 125, or ASIC (not shown) or a subset, superset, or combination of functions or features thereof, may be inte-

grated, distributed, or excluded, in whole or in part, based on an application, design, or form factor in accordance with one or more embodiments of the present invention. Thus, the description of computing system 100 is merely exemplary and not intended to limit the type, kind, or configuration of component devices that constitute a computing system 100 suitable for performing computing operations in accordance with one or more embodiments of the present invention.

[0051] One of ordinary skill in the art will recognize that computing system 100 may be a stand-alone, laptop, desktop, server, blade, or rack mountable system and may vary based on an application or design.

[0052] FIG. 2 shows a flexible datacenter 200 in accordance with one or more embodiments of the present invention. Flexible datacenter 200 may include a mobile container 205, a behind-the-meter power input system 210, a power distribution system 215, a climate control system (e.g., 250, 260, 270, 280, and/or 290), a datacenter control system 220, and a plurality of computing systems 100 disposed in one or more racks 240. Datacenter control system 220 may be a computing system (e.g., 100 of FIG. 1) configured to dynamically modulate power delivery to one or more computing systems 100 disposed within flexible datacenter 200 based on behind-the-meter power availability or an operational directive from a local station control system (not shown), a remote master control system (not shown), or a grid operator (not shown).

[0053] In certain embodiments, mobile container 205 may be a storage trailer disposed on wheels and configured for rapid deployment. In other embodiments, mobile container 205 may be a storage container (not shown) configured for placement on the ground and potentially stacked in a vertical or horizontal manner (not shown). In still other embodiments, mobile container 205 may be an inflatable container, a floating container, or any other type or kind of container suitable for housing a mobile datacenter 200. And in still other embodiments, flexible datacenter 200 might not include a mobile container. For example, flexible datacenter 200 may be situated within a building or another type of stationary environment.

[0054] Flexible datacenter 200 may be rapidly deployed on site near a source of unutilized behind-the-meter power generation. Behind-the-meter power input system 210 may be configured to input power to flexible datacenter 200. Behind-the-meter power input system 210 may include a first input (not independently illustrated) configured to receive three-phase behind-the-meter alternating current (“AC”) voltage. In certain embodiments, behind-the-meter power input system 210 may include a supervisory AC-to-AC step-down transformer (not shown) configured to step down three-phase behind-the-meter AC voltage to single-phase supervisory nominal AC voltage or a second input (not independently illustrated) configured to receive single-phase supervisory nominal AC voltage from the local station (not shown) or a metered source (not shown). Behind-the-meter power input system 210 may provide single-phase supervisory nominal AC voltage to datacenter control system 220, which may remain powered at almost all times to control the operation of flexible datacenter 200. The first input (not independently illustrated) or a third input (not independently illustrated) of behind-the-meter power input system 210 may direct three-phase behind-the-meter AC voltage to an operational AC-to-AC step-down transformer (not shown) configured to controllably step down three-

phase behind-the-meter AC voltage to three-phase nominal AC voltage. Datacenter control system 220 may controllably enable or disable generation or provision of three-phase nominal AC voltage by the operational AC-to-AC step-down transformer (not shown).

[0055] Behind-the-meter power input system 210 may provide three phases of three-phase nominal AC voltage to power distribution system 215. Power distribution system 215 may controllably provide a single phase of three-phase nominal AC voltage to each computing system 100 or group 240 of computing systems 100 disposed within flexible datacenter 200. Datacenter control system 220 may controllably select which phase of three-phase nominal AC voltage that power distribution system 215 provides to each computing system 100 or group 240 of computing systems 100. In this way, datacenter control system 220 may modulate power delivery by either ramping-up flexible datacenter 200 to fully operational status, ramping-down flexible datacenter 200 to offline status (where only datacenter control system 220 remains powered), reducing power consumption by withdrawing power delivery from, or reducing power to, one or more computing systems 100 or groups 240 of computing systems 100, or modulating a power factor correction factor for the local station by controllably adjusting which phases of three-phase nominal AC voltage are used by one or more computing systems 100 or groups 240 of computing systems 100. In some embodiments, flexible datacenter 200 may receive DC power to power computing systems 100.

[0056] Flexible datacenter 200 may include a climate control system (e.g., 250, 260, 270, 280, 290) configured to maintain the plurality of computing systems 100 within their operational temperature range. In certain embodiments, the climate control system may include an air intake 250, an evaporative cooling system 270, a fan 280, and an air outtake 260. In other embodiments, the climate control system may include an air intake 250, an air conditioner or refrigerant cooling system 290, and an air outtake 260. In still other embodiments, the climate control system may include a computer room air conditioner system (not shown), a computer room air handler system (not shown), or an immersive cooling system (not shown). One of ordinary skill in the art will recognize that any suitable heat extraction system (not shown) configured to maintain the operation of the plurality of computing systems 100 within their operational temperature range may be used in accordance with one or more embodiments of the present invention.

[0057] Flexible datacenter 200 may include a battery system (not shown) configured to convert three-phase nominal AC voltage to nominal DC voltage and store power in a plurality of storage cells. The battery system (not shown) may include a DC-to-AC inverter configured to convert nominal DC voltage to three-phase nominal AC voltage for flexible datacenter 200 use. Alternatively, the battery system (not shown) may include a DC-to-AC inverter configured to convert nominal DC voltage to single-phase nominal AC voltage to power datacenter control system 220.

[0058] One of ordinary skill in the art will recognize that a voltage level of three-phase behind-the-meter AC voltage may vary based on an application or design and the type or kind of local power generation. As such, a type, kind, or configuration of the operational AC-to-AC step down transformer (not shown) may vary based on the application or design. In addition, the frequency and voltage level of three-phase nominal AC voltage, single-phase nominal AC

voltage, and nominal DC voltage may vary based on the application or design in accordance with one or more embodiments of the present invention.

[0059] FIG. 3 shows a three-phase power distribution of a flexible datacenter 200 in accordance with one or more embodiments of the present invention. Flexible datacenter 200 may include a plurality of racks 240, each of which may include one or more computing systems 100 disposed therein. As discussed above, the behind-the-meter power input system (210 of FIG. 2) may provide three phases of three-phase nominal AC voltage to the power distribution system (215 of FIG. 2). The power distribution system (215 of FIG. 2) may controllably provide a single phase of three-phase nominal AC voltage to each computing system 100 or group 240 of computing systems 100 disposed within flexible datacenter 200. For example, a flexible datacenter 200 may include eighteen racks 240, each of which may include eighteen computing systems 100. The power distribution system (215 of FIG. 2) may control which phase of three-phase nominal AC voltage is provided to one or more computing systems 100, a rack 240 of computing systems 100, or a group (e.g., 310, 320, or 330) of racks 240 of computing systems 100.

[0060] In the figure, for purposes of illustration only, eighteen racks 240 are divided into a first group of six racks 310, a second group of six racks 320, and a third group of six racks 330, where each rack contains eighteen computing systems 100. The power distribution system (215 of FIG. 2) may, for example, provide a first phase of three-phase nominal AC voltage to the first group of six racks 310, a second phase of three-phase nominal AC voltage to the second group of six racks 320, and a third phase of three-phase nominal AC voltage to the third group of six racks 330, if the flexible datacenter (200 of FIG. 2) receives an operational directive from the local station (not shown) to provide power factor correction, the datacenter control system (220 of FIG. 2) may direct the power distribution system (215 of FIG. 2) to adjust which phase or phases of three-phase nominal AC voltage are used to provide the power factor correction required by the local station (not shown) or grid operator (not shown). One of ordinary skill in the art will recognize that, in addition to the power distribution, the load may be varied by adjusting the number of computing systems 100 operatively powered. As such, the flexible datacenter (200 of FIG. 2) may be configured to act as a capacitive or inductive load to provide the appropriate reactance necessary to achieve the power factor correction required by the local station (not shown).

[0061] FIG. 4 shows a control distribution scheme 400 of a flexible datacenter 200 in accordance with one or more embodiments of the present invention. Datacenter control system 220 may independently, or cooperatively with one or more of local station control system 410, remote master control system 420, and grid operator 440, modulate power delivery to flexible datacenter 200. Specifically, power delivery may be dynamically adjusted based on conditions or operational directives.

[0062] Local station control system 410 may be a computing system e.g., 100 of FIG. 1) that is configured to control various aspects of the local station (not independently illustrated) that generates power and sometimes generates unutilized behind-the-meter power. Local station control system 410 may communicate with remote master control system 420 over a networked connection 430 and

with datacenter control system 220 over a networked or hardwired connection 415. Remote master control system 420 may be a computing system (e.g., 100 of FIG. 1) that is located offsite, but connected via a network connection 425 to datacenter control system 220, that is configured to provide supervisory or override control of flexible datacenter 200 or a fleet (not shown) of flexible datacenters 200. Grid operator 440 may be a computing system (e.g., 100 of FIG. 1) that is configured to control various aspects of the grid (not independently illustrated) that receives power from the local station (not independently illustrated). Grid operator 440 may communicate with local station control system 440 over a networked or hardwired connection 445.

[0063] Datacenter control system 220 may monitor unutilized behind-the-meter power availability at the local station (not independently illustrated) and determine when a datacenter ramp-up condition is met. Unutilized behind-the-meter power availability may include one or more of excess local power generation, excess local power generation that the grid cannot accept, local power generation that is subject to economic curtailment, local power generation that is subject to reliability curtailment, local power generation that is subject to power factor correction, conditions where the cost for power is economically viable (e.g., low cost for power), situations where local power generation is prohibitively low, start up situations, transient situations, or testing situations where there is an economic advantage to using locally generated behind-the-meter power generation, specifically power available at little to no cost and with no associated transmission or distribution losses or costs.

[0064] The datacenter ramp-up condition may be met if there is sufficient behind-the-meter power availability and there is no operational directive from local station control system 410, remote master control system 420, or grid operator 440 to go offline or reduce power. As such, datacenter control system 220 may enable 435 behind-the-meter power input system 210 to provide three-phase nominal AC voltage to the power distribution system (215 of FIG. 2) to power the plurality of computing systems (100 of FIG. 2) or a subset thereof. Datacenter control system 220 may optionally direct one or more computing systems (100 of FIG. 2) to perform predetermined computational operations. For example, if the one or more computing systems (100 of FIG. 2) are configured to perform blockchain hashing operations, datacenter control system 220 may direct them to perform blockchain hashing operations for a specific blockchain application, such as, for example, Bitcoin, Litecoin, or Ethereum. Alternatively, one or more computing systems (100 of FIG. 2) may be configured to independently receive a computational directive from a network connection (not shown) to a peer-to-peer blockchain network (not shown) such as, for example, a network for a specific blockchain application, to perform predetermined computational operations.

[0065] Remote master control system 420 may specify to datacenter control system 220 what sufficient behind-the-meter power availability constitutes, or datacenter control system 220 may be programmed with a predetermined preference or criteria on which to make the determination independently. For example, in certain circumstances, sufficient behind-the-meter power availability may be less than that required to fully power the entire flexible datacenter 200. In such circumstances, datacenter control system 220 may provide power to only a subset of computing systems

(100 of FIG. 2), or operate the plurality of computing systems (100 of FIG. 2) in a lower power mode, that is within the sufficient, but less than full, range of power that is available.

[0066] While flexible datacenter 200 is online and operational, a datacenter ramp-down condition may be met when there is insufficient, or anticipated to be insufficient, behind-the-meter power availability or there is an operational directive from local station control system 410, remote master control system 420, or grid operator 440. Datacenter control system 220 may monitor and determine when there is insufficient, or anticipated to be insufficient, behind-the-meter power availability. As noted above, sufficiency may be specified by remote master control system 420 or datacenter control system 220 may be programmed with a predetermined preference or criteria on which to make the determination independently. An operational directive may be based on current dispatchability, forward looking forecasts for when unutilized behind-the-meter power is, or is expected to be, available, economic considerations, reliability considerations, operational considerations, or the discretion of the local station 410, remote master control 420, or grid operator 440. For example, local station control system 410, remote master control system 420, or grid operator 440 may issue an operational directive to flexible datacenter 200 to go offline and power down. When the datacenter ramp-down condition is met, datacenter control system 220 may disable power delivery to the plurality of computing systems (100 of FIG. 2). Datacenter control system 220 may disable 435 behind-the-meter power input system 210 from providing three-phase nominal AC voltage to the power distribution system (215 of FIG. 2) to power down the plurality of computing systems (100 of FIG. 2), while datacenter control system 220 remains powered and is capable of rebooting flexible datacenter 200 when unutilized behind-the-meter power becomes available again.

[0067] While flexible datacenter 200 is online and operational, changed conditions or an operational directive may cause datacenter control system 220 to modulate power consumption by flexible datacenter 200. Datacenter control system 220 may determine, or local station control system 410, remote master control system 420, or grid operator 440 may communicate, that a change in local conditions may result in less power generation, availability, or economic feasibility, than would be necessary to fully power flexible datacenter 200. In such situations, datacenter control system 220 may take steps to reduce or stop power consumption by flexible datacenter 200 (other than that required to maintain operation of datacenter control system 220). Alternatively, local station control system 410, remote master control system 420, or grid operator 440, may issue an operational directive to reduce power consumption for any reason, the cause of which may be unknown. In response, datacenter control system 220 may dynamically reduce or withdraw power delivery to one or more computing systems (100 of FIG. 2) to meet the dictate. Datacenter control system 220 may controllably provide three-phase nominal AC voltage to a smaller subset of computing systems (100 of FIG. 2) to reduce power consumption. Datacenter control system 220 may dynamically reduce the power consumption of one or more computing systems (100 of FIG. 2) by reducing their operating frequency or forcing them into a lower power mode through a network directive.

[0068] One of ordinary skill in the art will recognize that datacenter control system 220 may be configured to have a number of different configurations, such as a number or type or kind of computing systems (100 of FIG. 2) that may be powered, and in what operating mode, that correspond to a number of different ranges of sufficient and available unutilized behind-the-meter power availability. As such, datacenter control system 220 may modulate power delivery over a variety of ranges of sufficient and available unutilized behind-the-meter power availability.

[0069] FIG. 5 shows a control distribution of a fleet 500 of flexible datacenters 200 in accordance with one or more embodiments of the present invention. The control distribution of a flexible datacenter 200 shown and described with respect to FIG. 4 may be extended to a fleet 500 of flexible datacenters 200. For example, a first local station (not independently illustrated), such as, for example, a wind farm (not shown), may include a first plurality 510 of flexible datacenters 200a through 200d, which may be collocated or distributed across the local station (not shown). A second local station (not independently illustrated), such as, for example, another wind farm or a solar farm (not shown), may include a second plurality 520 of flexible datacenters 200e through 200h, which may be collocated or distributed across the local station (not shown). One of ordinary skill in the art will recognize that the number of flexible datacenters 200 deployed at a given station and the number of stations within the fleet may vary based on an application or design in accordance with one or more embodiments of the present invention.

[0070] Remote master control system 420 may provide supervisory control over fleet 500 of flexible datacenters 200 in a similar manner to that shown and described with respect to FIG. 4, with the added flexibility to make high level decisions with respect to fleet 500 that may be counterintuitive to a given station. Remote master control system 420 may make decisions regarding the issuance of operational directives to a given local station based on, for example, the status of each local station. Where flexible datacenters 200 are deployed, the workload distributed across fleet 500, and the expected computational demand required for the expected workload. In addition, remote master control system 420 may shift workloads from a first plurality 510 of flexible datacenters 200 to a second plurality 520 of flexible datacenters 200 for any reason, including, for example, a loss of unutilized behind-the-meter power availability at one local station and the availability of unutilized behind-the-meter power at another local station.

[0071] FIG. 6 shows a flexible datacenter 200 powered by one or more wind turbines 610 in accordance with one or more embodiments of the present invention. A wind farm 600 typically includes a plurality of wind turbines 610, each of which intermittently generates a wind-generated AC voltage. The wind-generated AC voltage may vary based on a type, kind, or configuration of farm 600, turbine 610, and incident wind speed. The wind-generated AC voltage is typically input into a turbine AC-to-AC step-up transformer (not shown) that is disposed within the nacelle (not independently illustrated) or at the base of the mast (not independently illustrated) of turbine 610. The turbine AC-to-AC step up transformer (not shown) outputs three-phase wind-generated AC voltage 620. Three-phase wind-generated AC voltage 620 produced by the plurality of wind turbines 610 is collected 625 and provided 630 to another AC-to-AC

step-up transformer 640 that steps up three-phase wind-generated AC voltage 620 to three-phase grid AC voltage 650 suitable for delivery to grid 660. Three-phase grid AC voltage 650 may be stepped down with an AC-to-AC step-down transformer 670 configured to produce three-phase local station AC voltage 680 provided to local station 690. One of ordinary skill in the art will recognize that the actual voltage levels may vary based on the type, kind, or number of wind turbines 610, the configuration or design of wind farm 600, and grid 660 that it feeds into.

[0072] The output side of AC-to-AC step-up transformer 640 that connects to grid 660 may be metered and is typically subject to transmission and distribution costs. In contrast, power consumed on the input side of AC-to-AC step-up transformer 640 may be considered behind-the-meter and is typically not subject to transmission and distribution costs. As such, one or more flexible datacenters 200 may be powered by three-phase wind-generated AC voltage 620. Specifically, in wind farm 600 applications, the three-phase behind-the-meter AC voltage used to power flexible datacenter 200 may be three-phase wind-generated AC voltage 620. As such, flexible datacenter 200 may reside behind-the-meter, avoid transmission and distribution costs, and may be dynamically powered when unutilized behind-the-meter power is available.

[0073] Unutilized behind-the-meter power availability may occur when there is excess local power generation. In high wind conditions, wind farm 600 may generate more power than, for example, AC-to-AC step-up transformer 640 is rated for. In such situations, wind farm 600 may have to take steps to protect its equipment from damage, which may include taking one or more turbines 610 offline or shunting their voltage to dummy loads or ground. Advantageously, one or more flexible datacenters 200 may be used to consume power on the input side of AC-to-AC step-up transformer 640, thereby allowing wind farm 600 to operate equipment within operating ranges while flexible datacenter 200 receives behind-the-meter power without transmission or distribution costs. The local station control system (not independently illustrated) of local station 690 may issue an operational directive to the one or more flexible datacenters 200 or to the remote master control system (420 of FIG. 4) to ramp-up to the desired power consumption level. When the operational directive requires the cooperative action of multiple flexible datacenters 200, the remote master control system (420 of FIG. 4) may determine how to power each individual flexible datacenter 200 in accordance with the operational directive or provide an override to each flexible datacenter 200.

[0074] Another example of unutilized behind-the-meter power availability is when grid 660 cannot, for whatever reason, take the power being produced by wind farm 600. In such situations, wind farm 600 may have to take one or more turbines 610 offline or shunt their voltage to dummy loads or ground. Advantageously, one or more flexible datacenters 200 may be used to consume power on the input side of AC-to-AC step-up transformer 640, thereby allowing wind farm 600 to either produce power to grid 660 at a lower level or shut down transformer 640 entirely while flexible datacenter 200 receives behind-the-meter power without transmission or distribution costs. The local station control system (not independently illustrated) of local station 690 or the grid operator (not independently illustrated) of grid 660 may issue an operational directive to the one or more flexible

datacenters 200 or to the remote master control system (420 of FIG. 4) to ramp-up to the desired power consumption level. When the operational directive requires the cooperative action of multiple flexible datacenters 200, the remote master control system (420 of FIG. 4) may determine how to power each individual flexible datacenter 200 in accordance with the operational directive or provide an override to each flexible datacenter 200.

[0075] Another example of unutilized behind-the-meter power availability is when wind farm 600 is selling power to grid 660 at a negative price that is offset by a production tax credit. In certain circumstances, the value of the production tax credit may exceed the price wind farm 600 would have to pay to grid 660 to offload their generated power. Advantageously, one or more flexible datacenters 200 may be used to consume power behind-the-meter, thereby allowing wind farm 600 to produce and obtain the production tax credit, but sell less power to grid 660 at the negative price. The local station control system (not independently illustrated) of local station 690 may issue an operational directive to the one or more flexible datacenters 200 or to the remote master control system (420 of FIG. 4) to ramp-up to the desired power consumption level. When the operational directive requires the cooperative action of multiple flexible datacenter 200, the remote master control system (420 of FIG. 4) may determine how to power each individual flexible datacenter 200 in accordance with the operational directive or provide an override to each flexible datacenter 200.

[0076] Another example of unutilized behind-the-meter power availability is when wind farm 600 is selling power to grid 660 at a negative price because grid 660 is oversupplied or is instructed to stand down and stop producing altogether. The grid operator (not independently illustrated) may select certain power generation stations to go offline and stop producing power to grid 660. Advantageously, one or more flexible datacenters 200 may be used to consume power behind-the-meter, thereby allowing wind farm 600 to stop producing power to grid 660, but making productive use of the power generated behind-the-meter without transmission or distribution costs. The local station control system (not independently illustrated) of the local station 690 or the grid operator (not independently illustrated) of grid 660 may issue an operational directive to the one or more flexible datacenters 200 or to the remote master control system (420 of FIG. 4) to ramp-up to the desired power consumption level. When the operational directive requires the cooperative action of multiple flexible datacenters 200, the remote master control system (420 of FIG. 4) may determine how to power each individual flexible datacenter 200 in accordance with the operational directive or provide an override to each flexible datacenter 200.

[0077] Another example of unutilized behind-the-meter power availability is when wind farm 600 is producing power to grid 660 that is unstable, out of phase, or at the wrong frequency, or grid 660 is already unstable, out of phase, or at the wrong frequency for whatever reason. The grid operator (not independently illustrated) may select certain power generation stations to go offline and stop producing power to grid 660. Advantageously, one or more flexible datacenters 200 may be used to consume power behind-the-meter, thereby allowing wind farm 600 to stop producing power to grid 660, but make productive use of the power generated behind-the-meter without transmission or

distribution costs. The local station control system (not independently illustrated) of local station 690 may issue an operational directive to the one or more flexible datacenters 200 or to the remote master control system (420 of FIG. 4) to ramp-up to the desired power consumption level. When the operational directive requires the cooperative action of multiple flexible datacenters 200, the remote master control system (420 of FIG. 4) may determine how to power each individual flexible datacenter 200 in accordance with the operational directive or provide an override to each flexible datacenter 200.

[0078] Further examples of unutilized behind-the-meter power availability is when wind farm 600 experiences low wind conditions that make it not economically feasible to power up certain components, such as, for example, the local station (not independently illustrated), but there may be sufficient behind-the-meter power availability to power one or more flexible datacenters 200. Similarly, unutilized behind-the-meter power availability may occur when wind farm 600 is starting up, or testing, one or more turbines 610. Turbines 610 are frequently offline for installation, maintenance, and service and must be tested prior to coming online as part of the array. One or more flexible datacenters 200 may be powered by one or more turbines 610 that are offline from farm 600. The above-noted examples of when unutilized behind-the-meter power is available are merely exemplary and are not intended to limit the scope of what one of ordinary skill in the art would recognize as unutilized behind-the-meter power availability. Unutilized behind-the-meter power availability may occur anytime there is power available and accessible behind-the-meter that is not subject to transmission and distribution costs and there is an economic advantage to using it.

[0079] One of ordinary skill in the art will recognize that wind farm 600 and wind turbine 610 may vary based on an application or design in accordance with one or more embodiments of the present invention.

[0080] FIG. 7 shows a flexible datacenter 200 powered by one or more solar panels 710 in accordance with one or more embodiments of the present invention. A solar farm 700 typically includes a plurality of solar panels 710, each of which intermittently generates a solar-generated DC voltage 720. Solar-generated DC voltage 720 may vary based on a type, kind, or configuration of farm 700, panel 710, and incident sunlight. Solar-generated DC voltage 720 produced by the plurality of solar panels 710 is collected 725 and provided 730 to a DC-to-AC inverter 740 that converts solar-generated DC voltage into three-phase solar-generated AC voltage 750. Three-phase solar-generated AC voltage 750 is provided to an AC-to-AC step-up transformer 760 that steps up three-phase solar-generated AC voltage to three-phase grid AC voltage 790. Three-phase grid AC voltage 790 may be stepped down with an AC-to-AC step-down transformer 785 configured to produce three-phase local station AC voltage 777 provided to local station 775. One of ordinary skill in the art will recognize that the actual voltage levels may vary based on the type, kind, or number of solar panels 710, the configuration or design of solar farm 700, and grid 790 that it feeds into. In some embodiments, the solar farm 700 may provide DC power directly to flexible datacenter 200 without a conversion to AC via the DC-to-AC inverter 740.

[0081] The output side of AC-to-AC step-up transformer 760 that connects to grid 790 may be metered and is

typically subject to transmission and distribution costs. In contrast, power consumed on the input side of AC-to-AC step-up transformer 760 may be considered behind-the-meter and is typically not subject to transmission and distribution costs. As such, one or more flexible datacenters 200 may be powered by three-phase solar-generated AC voltage 750. Specifically, in solar farm 700 applications, the three-phase behind-the-meter AC voltage used to power flexible datacenter 200 may be three-phase solar-generated AC voltage 750. As such, flexible datacenter 200 may reside behind-the-meter, avoid transmission and distribution costs, and may be dynamically powered when unutilized behind-the-meter power is available.

[0082] Unutilized behind-the-meter power availability may occur when there is excess local power generation. In high incident sunlight situations, solar farm 700 may generate more power than, for example, AC-to-AC step-up transformer 760 is rated for. In such situations, solar farm 700 may have to take steps to protect its equipment from damage, which may include taking one or more panels 710 offline or shunting their voltage to dummy loads or ground. Advantageously, one or more flexible datacenters 200 may be used to consume power on the input side of AC-to-AC step-up transformer 760, thereby allowing solar farm 700 to operate equipment within operating ranges while flexible datacenter 200 receives behind-the-meter power without transmission or distribution costs. The local station control system (not independently illustrated) of local station 775 may issue an operational directive to the one or more flexible datacenters 200 or to the remote master control system (420 of FIG. 4) to ramp-up to the desired power consumption level. When the operational directive requires the cooperative action of multiple flexible datacenters 200, the remote master control system (420 of FIG. 4) may determine how to power each individual flexible datacenter 200 in accordance with the operational directive or provide an override to each flexible datacenter 200.

[0083] Another example of unutilized behind-the-meter power availability is when grid 790 cannot, for whatever reason, take the power being produced by solar farm 700. In such situations, solar farm 700 may have to take one or more panels 710 offline or shunt their voltage to dummy loads or ground. Advantageously, one or more flexible datacenters 200 may be used to consume power on the input side of AC-to-AC step-up transformer 760, thereby allowing solar farm 700 to either produce power to grid 790 at a lower level or shut down transformer 760 entirely while flexible datacenter 200 receives behind-the-meter power without transmission or distribution costs. The local station control system (not independently illustrated) of local station 775 or the grid operator (not independently illustrated) of grid 790 may issue an operational directive to the one or more flexible datacenters 200 or to the remote master control system (420 of FIG. 4) to ramp-up to the desired power consumption level. When the operational directive requires the cooperative action of multiple flexible datacenters 200, the remote master control system (420 of FIG. 4) may determine how to power each individual flexible datacenter 200 in accordance with the operational directive or provide an override to each flexible datacenter 200.

[0084] Another example of unutilized behind-the-meter power availability is when solar farm 700 is selling power to grid 790 at a negative price that is offset by a production tax credit. In certain circumstances, the value of the production

tax credit may exceed the price solar farm 700 would have to pay to grid 790 to offload their generated power. Advantageously, one or more flexible datacenters 200 may be used to consume power behind-the-meter, thereby allowing solar farm 700 to produce and obtain the production tax credit, but sell less power to grid 790 at the negative price. The local station control system (not independently illustrated) of local station 775 may issue an operational directive to the one or more flexible datacenters 200 or to the remote master control system (420 of FIG. 4) to ramp-up to the desired power consumption level. When the operational directive requires the cooperative action of multiple flexible datacenter 200, the remote master control system (420 of FIG. 4) may determine how to power each individual flexible datacenter 200 in accordance with the operational directive or provide an override to each flexible datacenter 200.

[0085] Another example of unutilized behind-the-meter power availability is when solar farm 700 is selling power to grid 790 at a negative price because grid 790 is oversupplied or is instructed to stand down and stop producing altogether. The grid operator (not independently illustrated) may select certain power generation stations to go offline and stop producing power to grid 790. Advantageously, one or more flexible datacenters 200 may be used to consume power behind-the-meter, thereby allowing solar farm 700 to stop producing power to grid 790, but making productive use of the power generated behind-the-meter without transmission or distribution costs. The local station control system (not independently illustrated) of the local station 775 or the grid operator (not independently illustrated) of grid 790 may issue an operational directive to the one or more flexible datacenters 200 or to the remote master control system (420 of FIG. 4) to ramp-up to the desired power consumption level. When the operational directive requires the cooperative action of multiple flexible datacenters 200, the remote master control system (420 of FIG. 4) may determine how to power each individual flexible datacenter 200 in accordance with the operational directive or provide an override to each flexible datacenter 200.

[0086] Another example of unutilized behind-the-meter power availability is when solar farm 700 is producing power to grid 790 that is unstable, out of phase, or at the wrong frequency, or grid 790 is already unstable, out of phase, or at the wrong frequency for whatever reason. The grid operator (not independently illustrated) may select certain power generation stations to go offline and stop producing power to grid 790. Advantageously, one or more flexible datacenters 200 may be used to consume power behind-the-meter, thereby allowing solar farm 700 to stop producing power to grid 790, but make productive use of the power generated behind-the-meter without transmission or distribution costs. The local station control system (not independently illustrated) of local station 775 may issue an operational directive to the one or more flexible datacenters 200 or to the remote master control system (420 of FIG. 4) to ramp-up to the desired power consumption level. When the operational directive requires the cooperative action of multiple flexible datacenters 200, the remote master control system (420 of FIG. 4) may determine how to power each individual flexible datacenter 200 in accordance with the operational directive or provide an override to each flexible datacenter 200.

[0087] Further examples of unutilized behind-the-meter power availability is when solar farm 700 experiences

intermittent cloud cover such that it is not economically feasible to power up certain components, such as, for example local station 775, but there may be sufficient behind-the-meter power availability to power one or more flexible datacenters 200. Similarly, unutilized behind-the-meter power availability may occur when solar farm 700 is starting up, or testing, one or more panels 710. Panels 710 are frequently offline for installation, maintenance, and service and must be tested prior to coming online as part of the array. One or more flexible datacenters 200 may be powered by one or more panels 710 that are offline from farm 700. The above-noted examples of when unutilized behind-the-meter power is available are merely exemplary and are not intended to limit the scope of what one of ordinary skill in the art would recognize as unutilized behind-the-meter power availability. Behind-the-meter power availability may occur anytime there is power available and accessible behind-the-meter that is not subject to transmission and distribution costs and there is an economic advantage to using it.

[0088] One of ordinary skill in the art will recognize that solar farm 700 and solar panel 710 may vary based on an application or design in accordance with one or more embodiments of the present invention.

[0089] FIG. 8 shows a flexible datacenter 200 powered by flare gas 800 in accordance with one or more embodiments of the present invention. Flare gas 800 is combustible gas produced as a product or by-product of petroleum refineries, chemical plants, natural gas processing plants, oil and gas drilling rigs, and oil and gas production facilities. Flare gas 800 is typically burned off through a flare stack (not shown) or vented into the air. In one or more embodiments of the present invention, flare gas 800 may be diverted 812 to a gas-powered generator that produces three-phase gas-generated AC voltage 822. This power may be considered behind-the-meter and is not subject to transmission and distribution costs. As such, one or more flexible datacenters 200 may be powered by three-phase gas-generated AC voltage. Specifically, the three-phase behind-the-meter AC voltage used to power flexible datacenter 200 may be three-phase gas-generated AC voltage 822. Accordingly, flexible datacenter 200 may reside behind-the-meter, avoid transmission and distribution costs, and may be dynamically powered when unutilized behind-the-meter power is available.

[0090] FIG. 9A shows a method of dynamic power delivery to a flexible datacenter (200 of FIG. 2) using behind-the-meter power 900 in accordance with one or more embodiments of the present invention. In step 910, the datacenter control system (220 of FIG. 4), or the remote master control system (420 of FIG. 4), may monitor behind-the-meter power availability. In certain embodiments, monitoring may include receiving information or an operational directive from the local station control system (410 of FIG. 4) or the grid operator (440 of FIG. 4) corresponding to behind-the-meter power availability.

[0091] In step 920, the datacenter control system (220 of FIG. 4), or the remote master control system (420 of FIG. 4), may determine when a datacenter ramp-up condition is met. In certain embodiments, the datacenter ramp-up condition may be met when there is sufficient behind-the-meter power availability and there is no operational directive from the local station to go offline or reduce power. In step 930, the datacenter control system (220 of FIG. 4) may enable

behind-the-meter power delivery to one or more computing systems (100 of FIG. 2). In step 940, once ramped-up, the datacenter control system (220 of FIG. 4) or the remote master control system (420 of FIG. 4) may direct one or more computing systems (100 of FIG. 2) to perform predetermined computational operations. In certain embodiments, the predetermined computational operations may include the execution of one or more hashing functions.

[0092] While operational, the datacenter control system (220 of FIG. 4), or the remote master control system (420 of FIG. 4), may receive an operational directive to modulate power consumption. In certain embodiments, the operational directive may be a directive to reduce power consumption. In such embodiments, the datacenter control system (220 of FIG. 4) or the remote master control system (420 of FIG. 4) may dynamically reduce power delivery to one or more computing systems (100 of FIG. 2) or dynamically reduce power consumption of one or more computing systems. In other embodiments, the operational directive may be a directive to provide a power factor correction factor. In such embodiments, the datacenter control system (220 of FIG. 4) or the remote master control system (420 of FIG. 4) may dynamically adjust power delivery to one or more computing systems (100 of FIG. 2) to achieve a desired power factor correction factor. In still other embodiments, the operational directive may be a directive to go offline or power down. In such embodiments, the datacenter control system (220 of FIG. 4) may disable power delivery to one or more computing systems (100 of FIG. 2).

[0093] As such, FIG. 9B shows a method of dynamic power delivery to a flexible datacenter (200 of FIG. 2) using behind-the-meter power 950 in accordance with one or more embodiments of the present invention. In step 960, the datacenter control system (220 of FIG. 4), or the remote master control system (420 of FIG. 4), may monitor behind-the-meter power availability. In certain embodiments, monitoring may include receiving information or an operational directive from the local station control system (410 of FIG. 4) or the grid operator (440 of FIG. 4) corresponding to behind-the-meter power availability.

[0094] In step 970, the datacenter control system (220 of FIG. 4), or the remote master control system (420 of FIG. 4), may determine when a datacenter ramp-down condition is met. In certain embodiments, the datacenter ramp-down condition may be met when there is insufficient behind-the-meter power availability or anticipated to be insufficient behind-the-meter power availability or there is an operational directive from the local station to go offline or reduce power. In step 980, the datacenter control system (220 of FIG. 4) may disable behind-the-meter power delivery to one or more computing systems (100 of FIG. 2). In step 990, once ramped-down, the datacenter control system (220 of FIG. 4) remains powered and in communication with the remote master control system (420 of FIG. 4) so that it may dynamically power the flexible datacenter (200 of FIG. 2) when conditions change.

[0095] One of ordinary skill in the art will recognize that a datacenter control system (220 of FIG. 4) may dynamically modulate power delivery to one or more computing systems (100 of FIG. 2) of a flexible datacenter (200 of FIG. 2) based on behind-the-meter power availability or an operational directive. The flexible datacenter (200 of FIG. 2) may transition between a fully powered down state (while the datacenter control system remains powered), a fully pow-

ered up state, and various intermediate states in between. In addition, flexible datacenter (200 of FIG. 2) may have a blackout state, where all power consumption, including that of the datacenter control system (220 of FIG. 4) is halted. However, once the flexible datacenter (200 of FIG. 2) enters the blackout state, it will have to be manually rebooted to restore power to datacenter control system (220 of FIG. 4). Local station conditions or operational directives may cause flexible datacenter (200 of FIG. 2) to ramp-up, reduce power consumption, change power factor, or ramp-down.

[0096] FIG. 10 illustrates a system 1000 for managing available computational resources based on power-generation economics in accordance with one or more embodiments of the present invention. System 1000 includes flexible datacenter (200 of FIG. 2), the remote master control system (420 of FIG. 4), local station control system 410, and grid operator 440. In other embodiments, system 1000 may include more or fewer components arranged in other configurations.

[0097] System 1000 represents an example system capable of determining and providing an indication of computational resource availability based on power-generation economic signals. Power-generation economic signals may include information that can assist with the management of computing resources. A control system (e.g., datacenter control system (220 of FIG. 4) or the remote master control system (420 of FIG. 4)) may be configured to obtain and use power-generation economic signals to perform actions, such as adjusting power use rates of flexible datacenter (200 of FIG. 2) or to provide indications of computational resource availability to other components (e.g., one or more control systems).

[0098] A power-generation economic signal may represent information useful for managing computational resources. The information may depend on the source providing the power-generation economic signal. As such, a set of power-generation economic signals may indicate the purchase price for power from various sources (e.g., the power grid, B-T-M power sources), the availability of power from the power sources, and customers' price expectations for tasks performed by available computing resources (e.g., flexible datacenter 200). Within examples, different techniques may be used to determine the power-generation economic signals, including sensors or computing processing techniques.

[0099] In some embodiments, a power-generation economic signal may indicate power availability from a power source. Power availability may indicate a quantity of power available and a demand for the power from the power source. For example, a power-generation economic signal may indicate the power availability from the power grid and another power-generation economic signal may indicate power availability from a B-T-M power source (e.g., wind farm 600 of FIG. 6 or solar farm 700 of FIG. 7). As such, a control system may use power-generation economic signals representing power availability for power sources when managing flexible datacenter 200 or other computing systems. The control system may also be configured to provide an indication when power is available from a particular source using information from one or more power-generation economic signals.

[0100] A power-generation economic signal may also indicate a purchase price for power associated with supplying power to flexible datacenter 200 or another computing

system. The purchase price for power may represent the price associated with using B-T-M power to power computing systems of flexible datacenter 200. A power-generation economic signal may similarly be based on a cost of power received from the power grid or based on a cost associated with selling power from an amount of behind-the-meter power to a power grid. A power-generation economic signal may also be based on a comparison of a price for power grid power relative to a price for behind-the-meter power. The information specifying and comparing different prices for power from the different sources can be used when managing flexible datacenter 200, including determining when to switch power sources and when to ramp up or ramp down computing systems within flexible datacenter 200. Additionally, a control system may use the cost information to determine and provide an indication of computational resource availability to one or more computing devices, such as another control system or to indicate cost to a customers using flexible datacenter 200.

[0101] In some examples, cost for power from a power source may depend on multiple factors. For instance, power-generation economics may provide information that enables a control system to determine when utilizing flexible datacenter 200 to consume power from one or more B-T-M power sources to avoid paying fees to offload the power on the grid. In addition, although described separately, a power-generation economic signal may represent both the availability and cost for power from a power source. For example, a power-generation economic signal may convey the cost and availability for power supplied by a B-T-M power source, such as wind farm 600 of FIG. 6 or solar farm 700 of FIG. 7. The price of power may depend on availability with some situations arising where demand for the cost for power increases or decreases cost.

[0102] In some examples, a power-generation economic signal may represent a price that a customer is willing to pay to use available computational resources. Particularly, the control system may use prices set forth by a customer when managing available computational resources since the customers' preferences could impact management of computational resources in different ways. For example, the control system may adjust the number of computing systems (or number of flexible datacenters) used, the rate of power use by the computing systems, and the power sources used based on customer preferences. The control system may devote more resources at a higher cost to a customer willing to cover the costs for a high priority computing task.

[0103] Within examples, power-generation economic signals may convey other information that can be used to manage computational resources. The above examples of information represented within a power-generation economic signal are included for illustration purposes, but should not be construed as limiting. Additionally, the information represented in each power-generation economic signal may depend on the source providing the power-generation economic signal. In particular, a power-generation economic signal can include a variety of information that a control system may use to adjust power use of one or more flexible datacenters 200 or to convey computational resources availability.

[0104] Within system 1000, the datacenter control system (220 of FIG. 4), the remote master control system (420 of FIG. 4), or another component may obtain information indicative of power-generation economic signals. The con-

control system may query different sources or may automatically receive power-generation economic signals. As shown in FIG. 10, the datacenter control system 220 or the remote master control system 420 may receive power-generation economic signals from various sources, such as grid operator 440 via communication links 1040, 1050, local station control system 410 via communication links 415, 430, and other control systems. The datacenter control system 220 may also be configured to receive one or more power-generation economic signals or control instructions from the remote master control system 420. Similarly, the remote master control system 420 may receive one or more power-generation economic signals from the datacenter control system 220.

[0105] In some examples, the control system may receive a set of power-generation economic signals from multiple sources enabling a comparison of the information within the different signals to determine a strategy for managing available computational resources. Determining the strategy may involve using a weighted combination of multiple factors included within the computational resources. For example, the control system may perform an analysis to determine a cost-efficient way to use power from the available power sources to power flexible datacenter 200 at a price that satisfies customer expectations.

[0106] In some examples, the control system may analyze power-generation economic signals to identify changes in power-generation economic signals that exceed predefined threshold changes. A predefined threshold change may depend on the information represented in the particular power-generation economic signal. For example, a change in a power-generation economic signal may indicate a threshold change in purchase price or cost for power from a particular power source. This may trigger the control system to modify power use from the power source and provide an updated indication of available computational resources based on the change in the price for power.

[0107] A control system may also use one or more power-generation economic signals to identify when the availability of power from a power source exceeds a predefined threshold change. For example, a B-T-M power source may experience a threshold decrease or increase in power production due to environmental conditions (e.g., cloud cover, lack of wind) that can influence the use of power from that B-T-M power source.

[0108] A control system within system 1000 (e.g., the datacenter control system 220, the remote master control system 420) may also identify when a power-generation economic signal is below a predefined lower threshold or is above a predefined upper threshold. Predefined lower and upper thresholds may serve to alert the control system of substantial changes in the price for power from a source or availability of power. For example, the control system may identify when the cost of power from a power source falls below a predefined lower price threshold. The control system may direct flexible datacenter 200 to use power from the power source providing power for the lowest price. Similarly, the control system may also use power-generation economic signals to identify when power from a source exceeds a predefined upper price threshold. The control system may switch flexible datacenter 200 from using power from a particular power source when the price for power exceeds the upper price threshold.

[0109] When analyzing costs for power, the control system may factor the cost associated with offloading power from a B-T-M power source to the grid. In some situations, offloading power to the grid may cost money, which might be indicated within one or more power-generation economic signals. For instance, grid operator 440 or local station control system 410 may provide an indication to a control system that indicates an increase in the cost associated with offloading power from the B-T-M power source to the grid. As a result, the control system may adjust power use by one or more flexible datacenters 200 to use at least some of the power from the B-T-M power source.

[0110] FIG. 11 shows a method 1100 for managing available computational resources based on power-generation economics in accordance with one or more embodiments of the present invention. Other methods are possible within examples.

[0111] At block 1102, method 1100 involves receiving information indicative of a plurality of power-generation economic signals. For example, a first control system may receive the information indicative of the power-generation economic signals. The first control system may be a datacenter associated with a flexible datacenter. For instance, the first control system may include a datacenter control system collocated with the flexible datacenter. As such, the first control system may be configured to receive power from a power grid.

[0112] In some embodiments, the first control system may be a remote master control system located remote from the flexible datacenter. As such, the remote master control system may communicate with a datacenter control system associated with the flexible datacenter.

[0113] In some embodiments, at least one or more power-generation economic signals of the plurality of power-generation economic signals are based on a cost of power received from a power grid.

[0114] In some embodiments, at least one or more power-generation economic signals of the plurality of power-generation economic signals are based on a purchase price for power associated with the flexible datacenter.

[0115] In some embodiments, at least one or more power-generation economic signals of the plurality of power-generation economic signals are based on a cost associated with selling power from an amount of behind-the-meter power to a power grid.

[0116] In some embodiments, at least one or more power-generation economic signals of the plurality of power-generation economic signals are based on a comparison of a first price for power grid power relative to a second price for behind-the-meter power.

[0117] At block 1104, method 1100 involves, based on the received information, identifying, by the first control system, at least one of: (i) a change indicative of a power-generation economic signal that exceeds a predefined threshold change, (ii) a power-generation economic signal that is below a predefined lower threshold limit, or (iii) a power-generation economic signal that is above a predefined upper threshold limit.

[0118] At block 1106, method 1100 involves, based on the identification, performing at least one of (i) adjusting a rate of power use by a flexible datacenter and (ii) providing an indication of computation resource availability to a second control system. The flexible datacenter may include a behind-the-meter power input system, a power distribution

system, and a plurality of computing systems configured to receive power from the behind-the-meter power input system via the power distribution system. The plurality of computing systems may also be configured to receive power from a power grid via the power distribution system. As a result, the plurality of computing systems may be capable of switching between receiving behind-the-meter power and grid power.

[0119] The second control system may include a datacenter control system collocated with the flexible datacenter. As such, the second control system may be configured to receive power from a power grid. For instance, power from the power grid may be used to keep the control powered up when the flexible datacenter ramps down. In other embodiments, the second control system may be a remote master control system located remote from the flexible datacenter. In some embodiments, the first control system and the second control system are part of the same control system.

[0120] Advantages of one or more embodiments of the present invention may include one or more of the following:

[0121] In one or more embodiments of the present invention, a method and system for dynamic power delivery to a flexible datacenter using unutilized energy sources based on power-generation economic signals may adjust a rate of power used by the flexible datacenter. An indication of computational resource availability may also be provided based on power-generation economic signals.

[0122] In one or more embodiments of the present invention, a method and system for dynamic power delivery to a flexible datacenter using unutilized energy sources based on power-generation economic signals may decrease costs associated with powering the flexible datacenter. The power-generation economic signals may enable switching between power sources offering power for the lowest price.

[0123] In one or more embodiments of the present invention, a method and system for dynamic power delivery to a flexible datacenter using unutilized energy sources allows for the rapid deployment of mobile datacenters to local stations. The mobile datacenters may be deployed on site, near the source of power generation, and receive unutilized behind-the-meter power when it is available.

[0124] In one or more embodiments of the present invention, a method and system for dynamic power delivery to a flexible datacenter using unutilized energy sources allows for the power delivery to the datacenter to be modulated based on conditions or an operational directive received from the local station or the grid operator.

[0125] In one or more embodiments of the present invention, a method and system for dynamic power delivery to a flexible datacenter using energy sources may dynamically adjust power consumption by ramping-up, ramping-down, or adjusting the power consumption of one or more computing systems within the flexible datacenter.

[0126] In one or more embodiments of the present invention, a method and system for dynamic power delivery to a flexible datacenter using unutilized energy sources may be powered by unutilized behind-the-meter power that is free from transmission and distribution costs. As such, the flexible datacenter may perform computational operations, such as hashing function operations, with little to no energy cost.

[0127] In one or more embodiments of the present invention, a method and system for dynamic power delivery to a flexible datacenter using unutilized energy sources provides a number of benefits to the hosting local station. The local

station may use the flexible datacenter to adjust a load, provide a power factor correction, to offload power, or operate in a manner that invokes a production tax credit.

[0128] In some scenarios, a local station control system might be able to act more quickly than a remote master control system in directing a flexible datacenter to modulate its power consumption. In these and other scenarios, actions by the local station control system would not require communications (e.g., directives, or power availability information) to be routed through the remote master control system, and thus, such communications would not be blocked or delayed by the remote master control system.

[0129] Conversely, the remote master control system can act on information that is not available to the local station control system, such as performance data or other data related to the flexible datacenter and the computing systems thereof, as discussed above. For at least this reason, it could be advantageous in some scenarios to have the remote master control system direct the flexible datacenter in addition to or instead of the local station control system. (One of the reasons for why the local station control system might not have access to this type of information is that the flexible datacenter and the remote master control system are operated by or otherwise associated with the same entity, whereas the local station control system is operated by a different entity.) Thus, in one or more embodiments of the present invention, a method and system for distributed power control allows for a datacenter control system of a flexible datacenter to be in communication with a remote master control system, which in turn allows the remote master control system to issue directives to the flexible datacenter based on various conditions associated with a behind-the-meter power source. Thus, the method and system for distributed power control allows for power consumption by the flexible datacenter to be modulated based on ramp-down and/or ramp-up directives received from the remote master control system.

[0130] One or more embodiments of the present invention provides a green solution to two prominent problems: the exponential increase in power required for growing block-chain operations and the unutilized and typically wasted energy generated from renewable energy sources.

[0131] One or more embodiments of the present invention allows for the rapid deployment of mobile datacenters to local stations. The mobile datacenters may be deployed on site, near the source of power generation, and receive unutilized behind-the-meter power when it is available.

[0132] One or more embodiments of the present invention allows for the power delivery to the datacenter to be modulated based on conditions or an operational directive received from the local station or the grid operator.

[0133] One or more embodiments of the present invention may dynamically adjust power consumption by ramping-up, ramping-down, or adjusting the power consumption of one or more computing systems within the flexible datacenter.

[0134] One or more embodiments of the present invention may be powered by behind-the-meter power that is free from transmission and distribution costs. As such, the flexible datacenter may perform computational operations, such as hashing function operations, with little to no energy cost.

[0135] One or more embodiments of the present invention provides a number of benefits to the hosting local station. The local station may use the flexible datacenter to adjust a load, provide a power factor correction, to offload power, or

operate in a manner that invokes a production tax credit and/or generates incremental revenue.

[0136] One or more embodiments of the present invention allows for continued shunting of behind-the-meter power into a storage solution when a flexible datacenter cannot fully utilize excess generated behind-the-meter power.

[0137] One or more embodiments of the present invention allows for continued use of stored behind-the-meter power when a flexible datacenter can be operational but there is not an excess of generated behind-the-meter power.

[0138] It will also be recognized by the skilled worker that, in addition to improved efficiencies in controlling power delivery from intermittent generation sources, such as wind farms and solar panel arrays, to regulated power grids, the invention provides more economically efficient control and stability of such power grids in the implementation of the technical features as set forth herein.

[0139] While the present invention has been described with respect to the above-noted embodiments, those skilled in the art, having the benefit of this disclosure, will recognize that other embodiments may be devised that are within the scope of the invention as disclosed herein. Accordingly, the scope of the invention should be limited only by the appended claims.

What is claimed is:

1. A method comprising:
 - receiving, at a first control system, information indicative of a plurality of power-generation economic signals;
 - based on the received information, identifying, by the first control system, at least one of: (i) a change indicative of a power-generation economic signal that exceeds a predefined threshold change, (ii) a power-generation economic signal that is below a predefined lower threshold limit, or (iii) a power-generation economic signal that is above a predefined upper threshold limit; and
 - based on the identification, performing at least one of: (i) adjusting a rate of power use by a flexible datacenter and (ii) providing an indication of computation resource availability to a second control system,
 wherein the flexible datacenter comprises a behind-the-meter power input system, a power distribution system, and a plurality of computing systems configured to receive power from the behind-the-meter power input system via the power distribution system.
2. The method of claim 1, wherein the first control system comprises a datacenter control system collocated with the flexible datacenter.
3. The method of claim 2, wherein the first control system is configured to receive power from a power grid.
4. The method of claim 1, wherein the first control system comprises a remote master control system located remote from the flexible datacenter.
5. The method of claim 1, wherein the second control system comprises a datacenter control system collocated with the flexible datacenter.
6. The method of claim 5, wherein the second control system is configured to receive power from a power grid.
7. The method of claim 1, wherein the second control system comprises a remote master control system located remote from the flexible datacenter.
8. The method of claim 1, wherein the first control system and the second control system are the same control system.

9. The method of claim 1, wherein the plurality of computing systems are further configured to also receive power from a power grid via the power distribution system.

10. The method of claim 9, wherein the plurality of computing systems are capable of switching between receiving behind-the-meter power and grid power.

11. The method of claim 1, wherein at least one or more power-generation economic signals of the plurality of power-generation economic signals are based on a cost of power received from a power grid.

12. The method of claim 1, wherein at least one or more power-generation economic signals of the plurality of power-generation economic signals are based on a purchase price for power associated with the flexible datacenter.

13. The method of claim 1, wherein at least one or more power-generation economic signals of the plurality of power-generation economic signals are based on a cost associated with selling power from an amount of behind-the-meter power to a power grid.

14. The method of claim 1, wherein at least one or more power-generation economic signals of the plurality of power-generation economic signals are based on a comparison of a first price for power grid power relative to a second price for behind-the-meter power.

15. A system comprising:

a flexible datacenter comprising:

- a behind-the-meter power input system,
- a power distribution system, and
- a plurality of computing systems configured to receive power from the behind-the-meter power input system via the power distribution system; and

a first control system configured to:

- receive information indicative of a plurality of power-generation economic signals;
- based on the received information, identify at least one of:

- (i) a change indicative of a power-generation economic signal that exceeds a predefined threshold change,

- (ii) a power-generation economic signal that is below a predefined lower threshold limit, or

- (iii) a power-generation economic signal that is above a predefined upper threshold limit; and

based on the identification, perform at least one of

- (i) adjusting a rate of power use by a flexible datacenter, and

- (ii) providing an indication of computation resource availability to a second control system.

16. The system of claim 15, wherein the first control system comprises a datacenter control system collocated with the flexible datacenter.

17. The system of claim 15, wherein the first control system comprises a remote master control system located remote from the flexible datacenter.

18. The system of claim 15, wherein at least one or more power-generation economic signals of the plurality of power-generation economic signals are based on a purchase price for power associated with the flexible datacenter.

19. The system of claim 15, wherein at least one or more power-generation economic signals of the plurality of power-generation economic signals are based on a comparison of a first price for power grid power relative to a second price for behind-the-meter power.

20. A non-transitory computer-readable medium configured to store instructions, that when executed by one or more processors, cause a control system to perform functions comprising:

receiving information indicative of a plurality of power-generation economic signals;

based on the received information, identifying at least one of:

(i) a change indicative of a power-generation economic signal that exceeds a predefined threshold change,

(ii) a power-generation economic signal that is below a predefined lower threshold limit, or

(iii) a power-generation economic signal that is above a predefined upper threshold limit; and

based on the identification, performing at least one of:

(i) adjusting a rate of power use by a flexible datacenter, and

(ii) providing an indication of computation resource availability to a second control system,

wherein the flexible datacenter comprises a behind-the-meter power input system, a power distribution system, and a plurality of computing systems configured to receive power from the behind-the-meter power input system via the power distribution system.

* * * * *