



US011980827B2

(12) **United States Patent**  
**Shilo et al.**

(10) **Patent No.:** **US 11,980,827 B2**  
(45) **Date of Patent:** **May 14, 2024**

(54) **TELESCOPIC ITEM AND MECHANISM THEREFOR**

(71) Applicant: **Hasbro, Inc.**, Pawtucket, RI (US)

(72) Inventors: **Yair Shilo**, Kibbutz Shefayim (IL);  
**Amitai David Fried**, Givat Shmuel (IL)

(\* ) Notice: Subject to any disclaimer, the term of this patent is extended or adjusted under 35 U.S.C. 154(b) by 271 days.

(21) Appl. No.: **17/539,525**

(22) Filed: **Dec. 1, 2021**

(65) **Prior Publication Data**

US 2022/0088498 A1 Mar. 24, 2022

**Related U.S. Application Data**

(63) Continuation-in-part of application No. PCT/IB2020/055255, filed on Jun. 3, 2020.

(60) Provisional application No. 62/856,763, filed on Jun. 4, 2019.

(51) **Int. Cl.**  
**A63H 33/00** (2006.01)  
**A63H 33/22** (2006.01)  
**F16B 7/10** (2006.01)

(52) **U.S. Cl.**  
CPC ..... **A63H 33/009** (2013.01); **A63H 33/22** (2013.01)

(58) **Field of Classification Search**  
CPC ..... A63H 33/009; A63H 33/22; Y10T 74/18672; F16B 7/105  
USPC ..... 446/473, 485, 487; 463/47.2, 47.7  
See application file for complete search history.

(56) **References Cited**

**U.S. PATENT DOCUMENTS**

3,037,320 A \* 6/1962 Powell ..... A63H 33/009 446/487  
3,799,485 A \* 3/1974 Wolters ..... A47C 3/24 248/406.1

4,062,156 A \* 12/1977 Roth ..... F16B 7/105 343/903  
4,678,450 A \* 7/1987 Scolari ..... A63H 33/009 362/202  
4,697,228 A \* 9/1987 Mui ..... F21L 4/02 362/208  
4,793,197 A \* 12/1988 Petrovsky ..... F16H 25/20 248/161

(Continued)

**FOREIGN PATENT DOCUMENTS**

CN 2084840 U 9/1991  
CN 202507284 U 10/2012

(Continued)

**OTHER PUBLICATIONS**

PCT/IB2020/055255 ISR Transmittal, Written Opinion, and ISA Search 15225-PCT papers dated Sep. 10, 2020.

*Primary Examiner* — Alexander R Niconovich

(74) *Attorney, Agent, or Firm* — Dekel Patent Ltd.; David Klein

(57) **ABSTRACT**

A telescopic mechanism including hollow telescopic blade segments with a threaded spindle having spindle threads within the telescopic blade segments. Nuts are configured to correspond and interface with the spindle, and a power mechanism is configured to spin the spindle. Each of the nuts respectively interfaces at the proximal portion of each of the hollow blade segments and the nuts have nut threads corresponding to the spindle threads. The nut threads allow back and forth movement over the spindle threads when the spindle is rotated; however, the nut threads will slide over the spindle threads if the distal telescopic blade segment is pushed above a given threshold force.

**36 Claims, 20 Drawing Sheets**

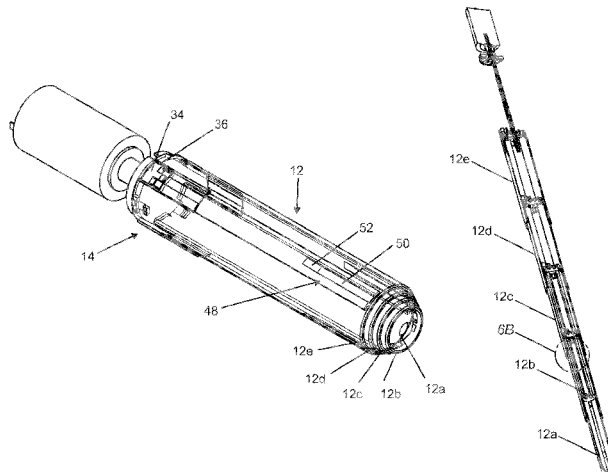

(56)

**References Cited**

U.S. PATENT DOCUMENTS

5,145,446 A \* 9/1992 Kuo ..... A63H 5/04  
 446/485  
 5,149,092 A \* 9/1992 Parsons ..... F41B 15/027  
 463/47.7  
 5,279,513 A \* 1/1994 Connelly ..... A63H 33/009  
 446/485  
 5,947,789 A \* 9/1999 Chan ..... A63H 33/009  
 446/485  
 6,082,876 A \* 7/2000 Hanson ..... F21V 9/45  
 362/186  
 7,611,398 B2 \* 11/2009 Woodhouse ..... A63H 33/009  
 446/485  
 7,684,694 B2 \* 3/2010 Fromm ..... F16M 11/28  
 10,065,127 B1 \* 9/2018 Honeck ..... A63H 33/26  
 10,376,803 B2 8/2019 Honeck et al.  
 10,500,518 B2 \* 12/2019 Graves ..... A63H 33/009  
 11,129,465 B1 \* 9/2021 Goslin ..... F21V 21/145  
 11,484,810 B2 \* 11/2022 Faivre ..... A63H 33/22  
 2003/0183027 A1 \* 10/2003 Koch ..... F16H 25/20  
 74/89.35  
 2004/0127292 A1 \* 7/2004 Chan ..... A63H 33/009  
 463/47.2

2006/0091277 A1 \* 5/2006 Wang ..... A47G 33/06  
 248/405  
 2007/0254553 A1 \* 11/2007 Wan ..... A63H 33/22  
 446/175  
 2007/0270077 A1 11/2007 Woodhouse  
 2009/0145056 A1 \* 6/2009 Pereira ..... E04H 12/182  
 52/111  
 2010/0018334 A1 \* 1/2010 Lessing ..... F16H 25/20  
 74/89.35  
 2014/0106644 A1 \* 4/2014 Urbaniak ..... A63H 33/00  
 446/487  
 2018/0326317 A1 11/2018 Honeck et al.  
 2019/0232183 A1 \* 8/2019 Siddeeq ..... A63H 33/009  
 2022/0203252 A1 \* 6/2022 Fahmie ..... A63H 33/009  
 2022/0410026 A1 \* 12/2022 Sacha ..... A63H 33/009

FOREIGN PATENT DOCUMENTS

CN 203037144 U \* 7/2013  
 CN 105587722 B 11/2017  
 IN 103644277 B 6/2016  
 TW 106218727 U 3/2018

\* cited by examiner

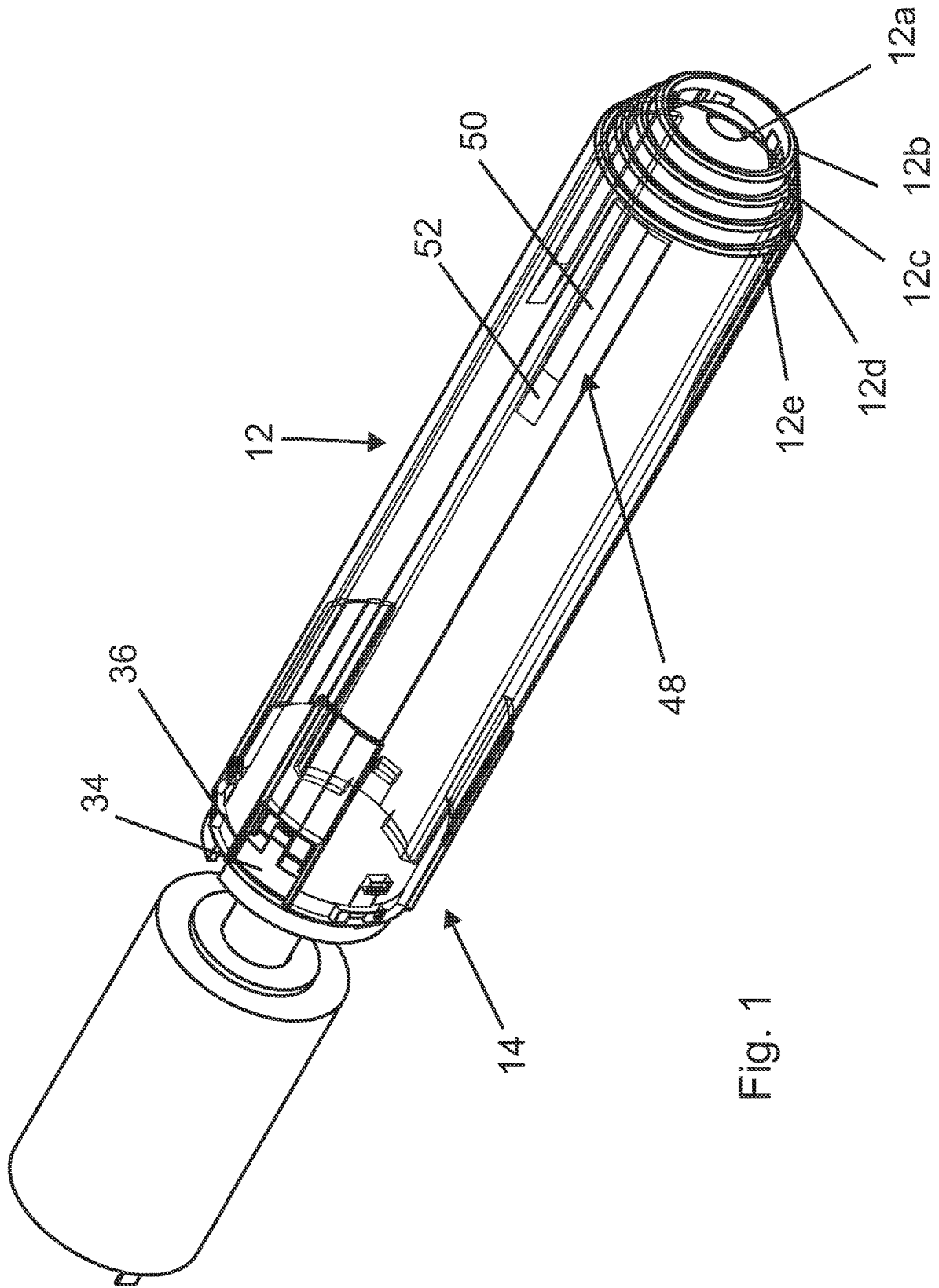

Fig. 1

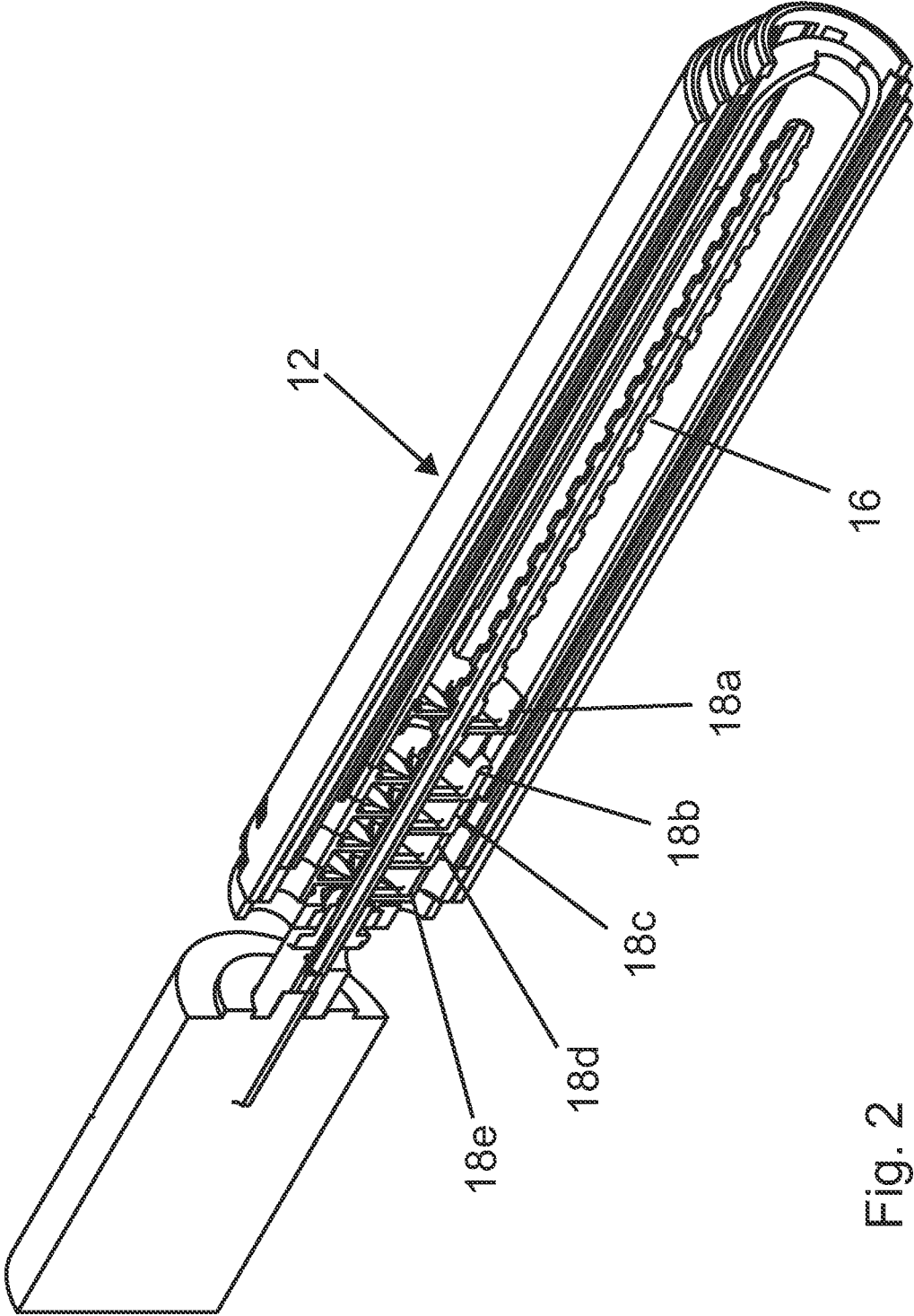
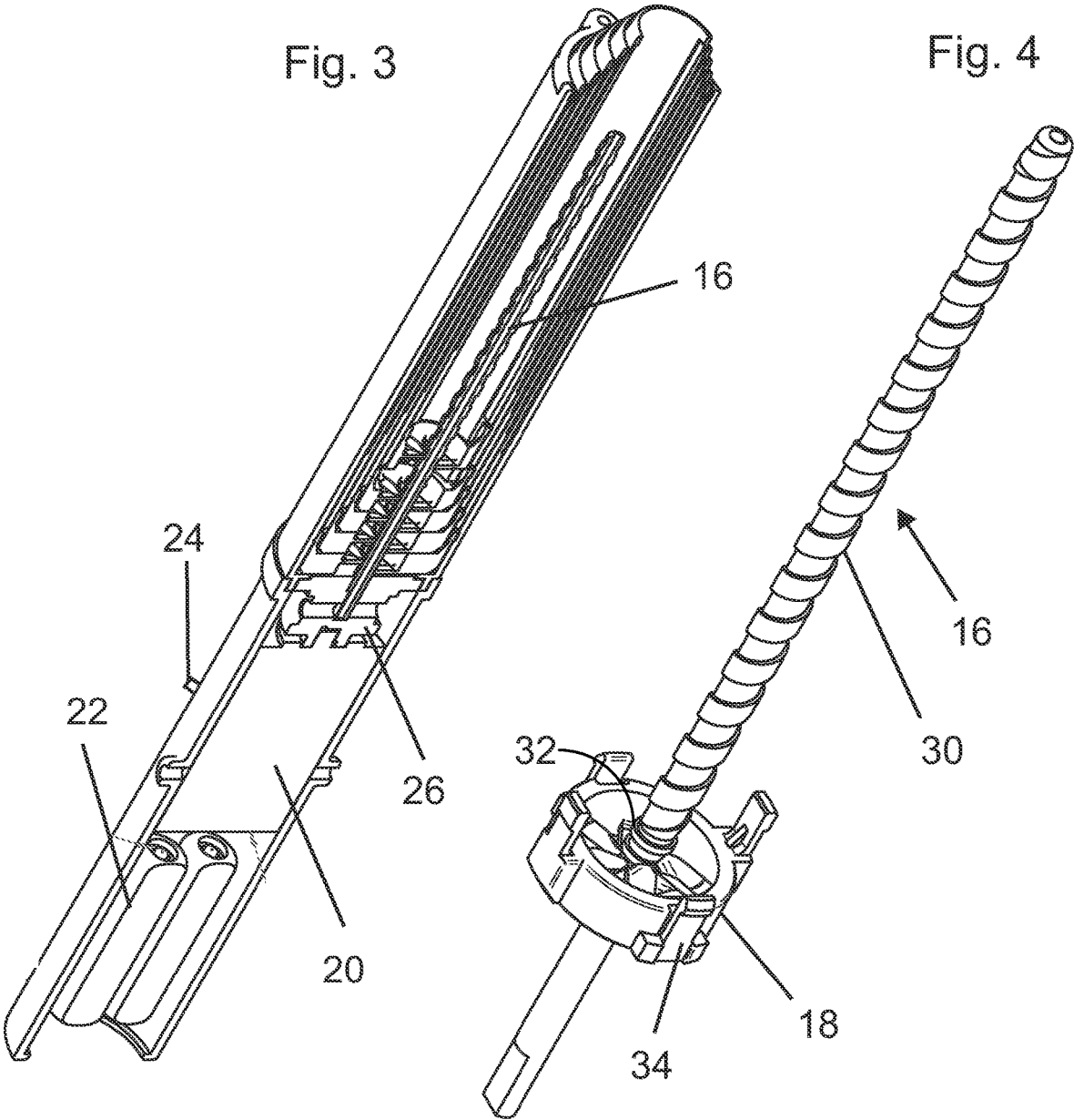

Fig. 2



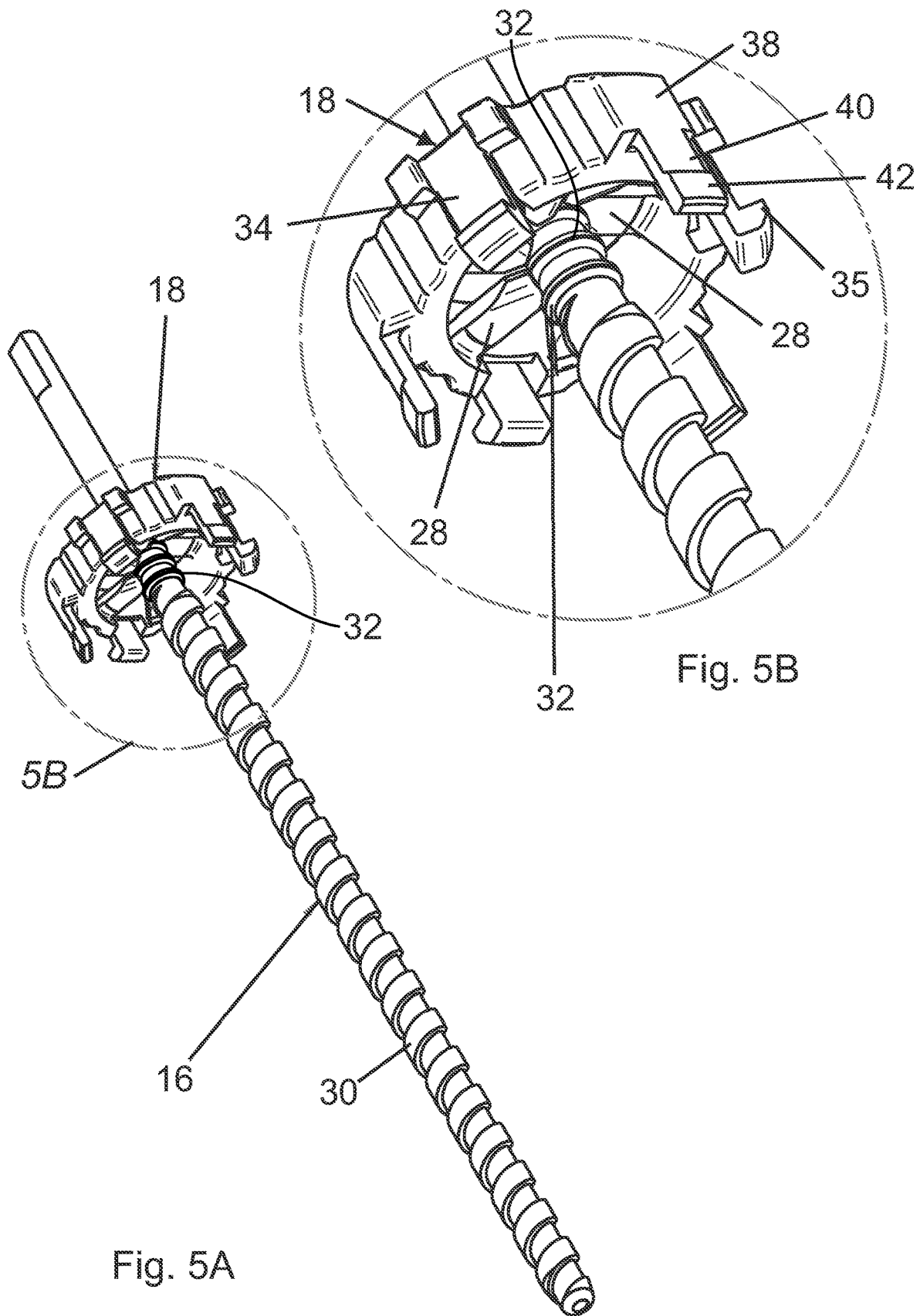

Fig. 5A

Fig. 5B

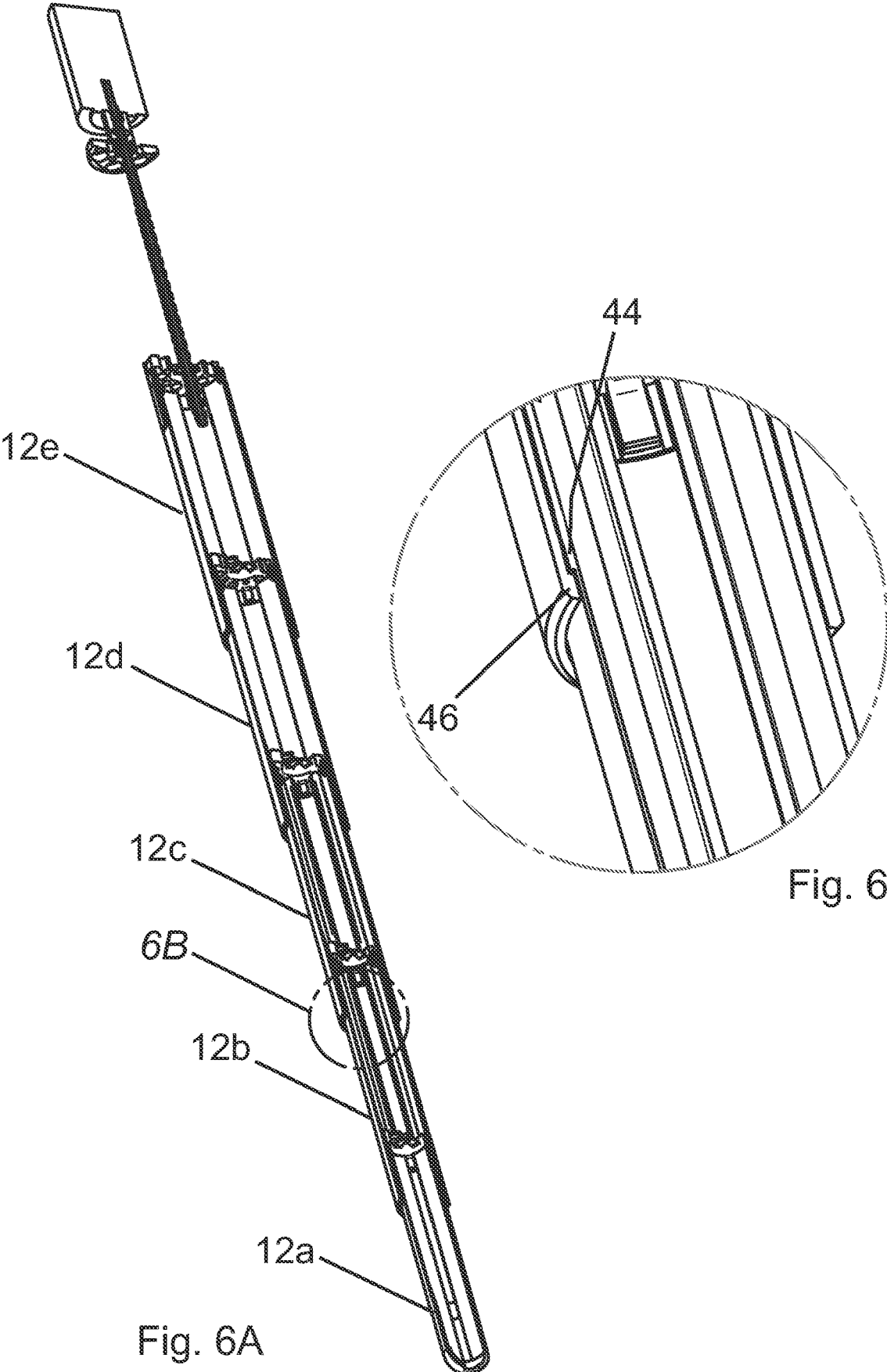

Fig. 6A

Fig. 6B

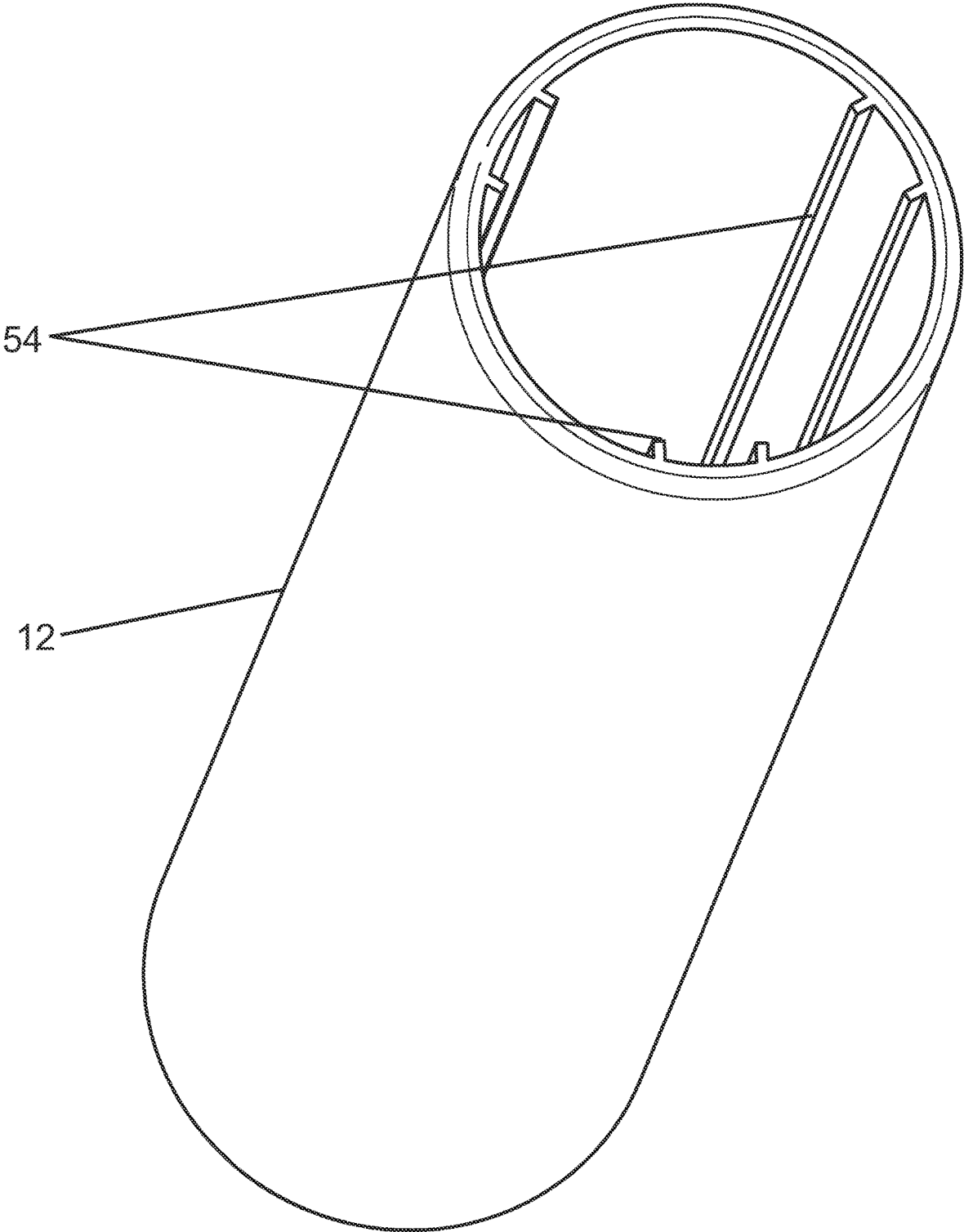

Fig. 7



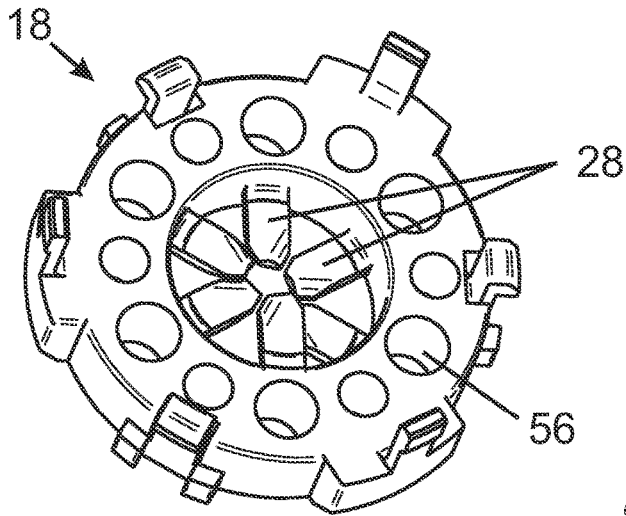

Fig. 8A

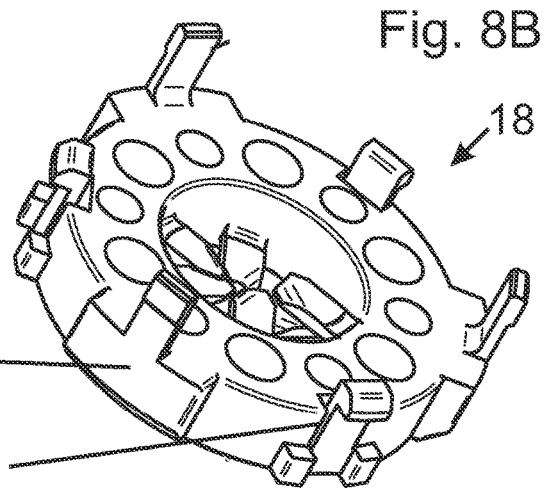

Fig. 8B

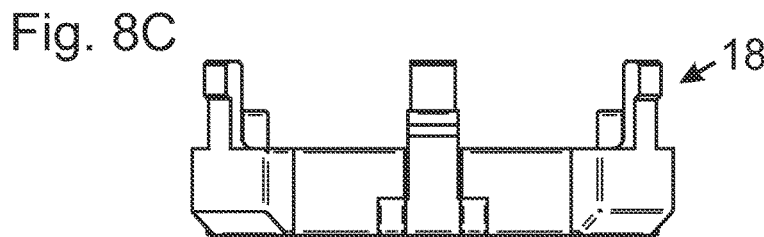

Fig. 8C

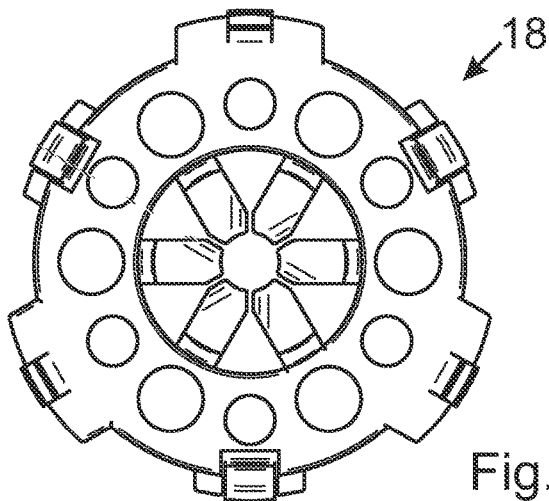

Fig. 8D

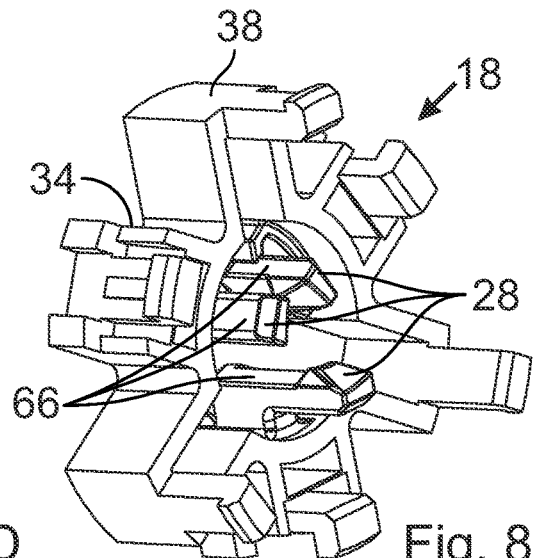

Fig. 8E

Fig. 9A

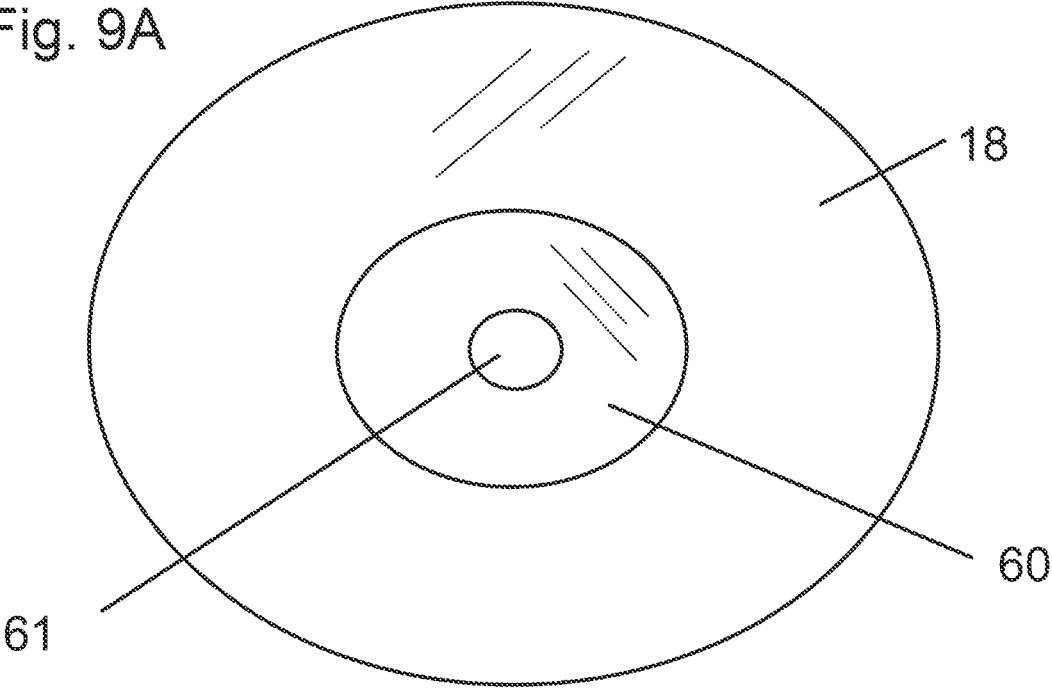

Fig. 9B

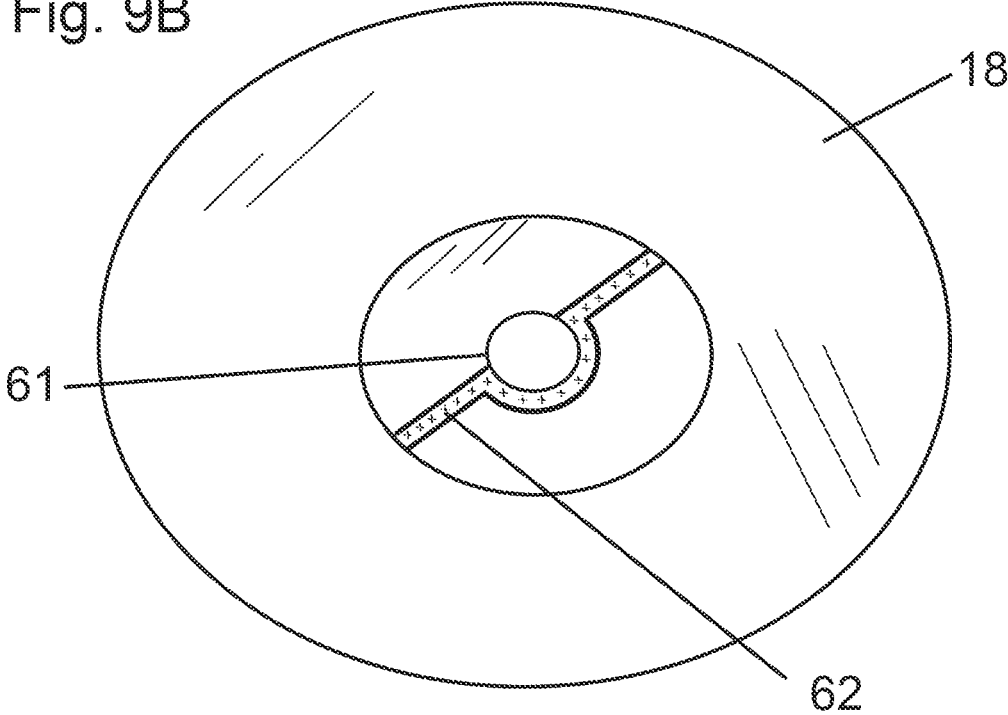

Fig. 9C

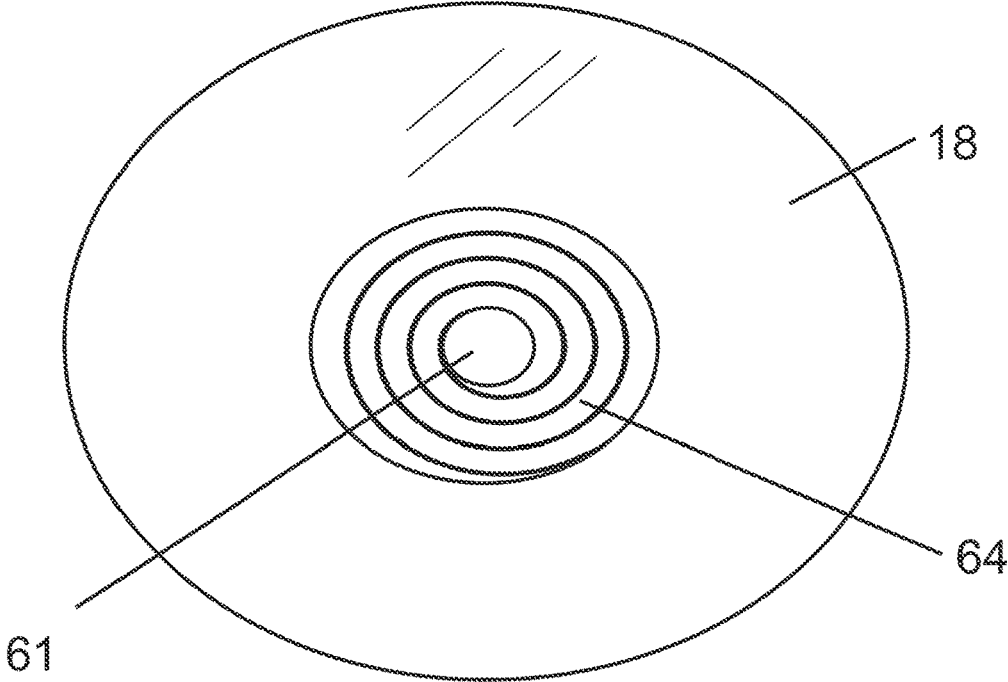

Fig. 9D

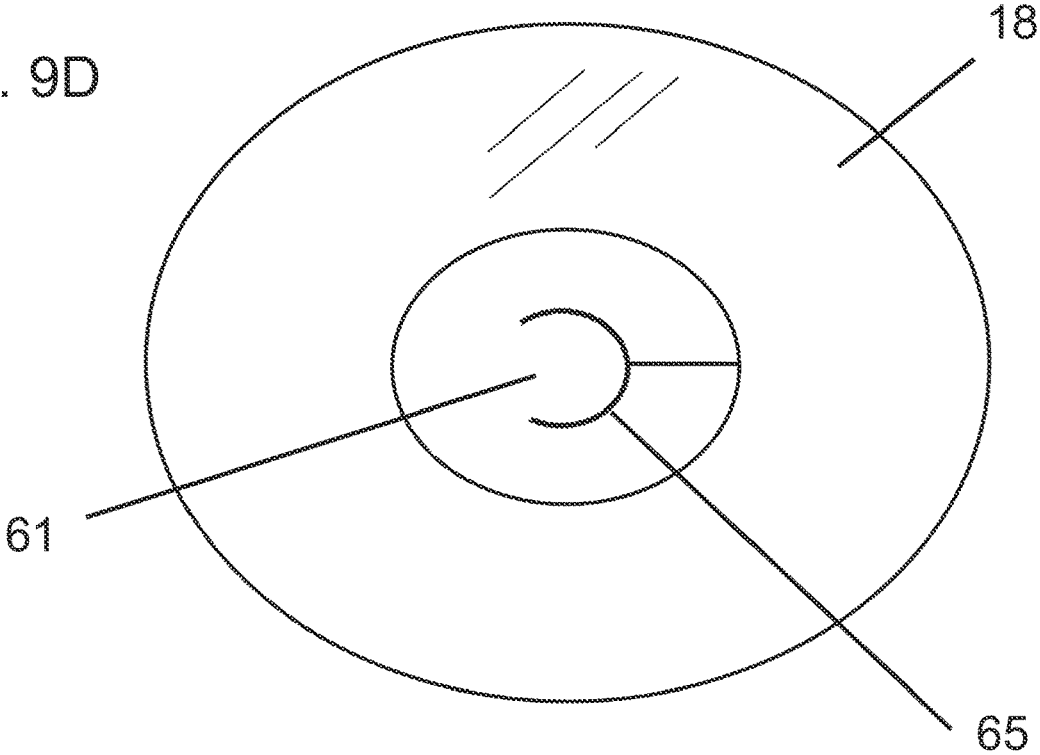

Fig. 9E

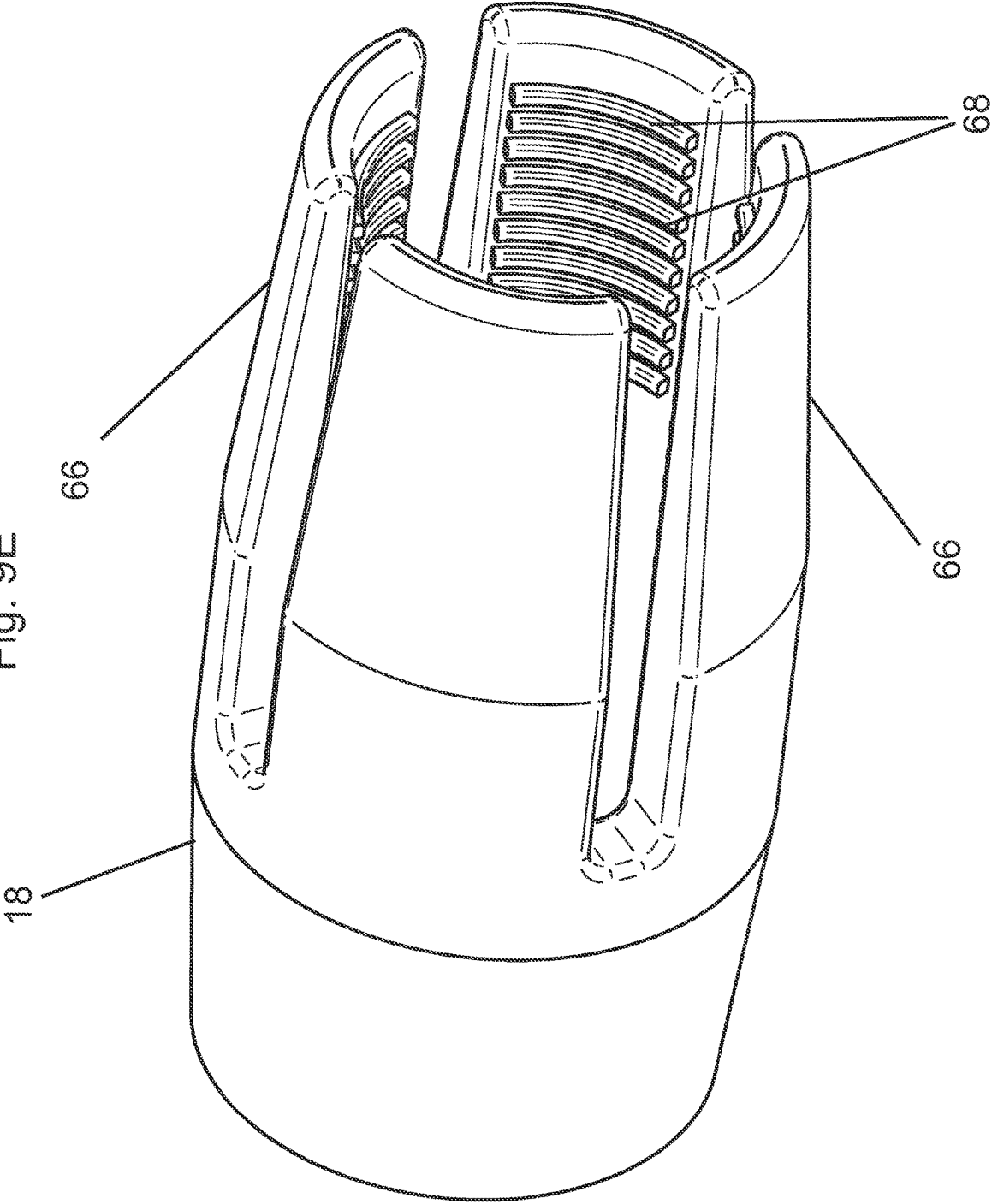
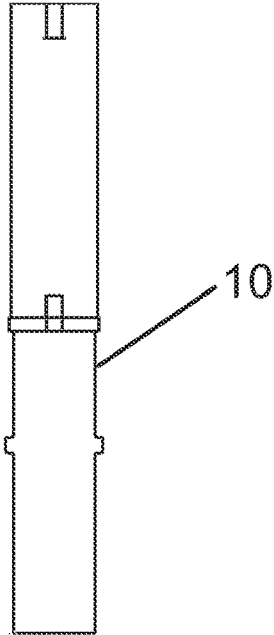

Fig. 10A



10

12

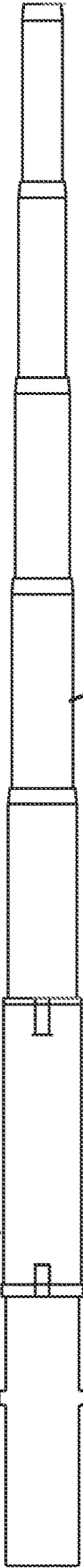

Fig. 10B

Fig. 11

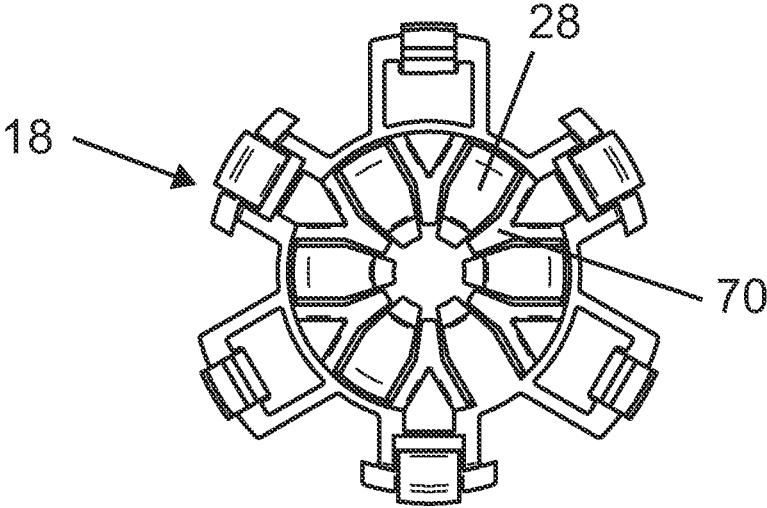

Fig. 12B

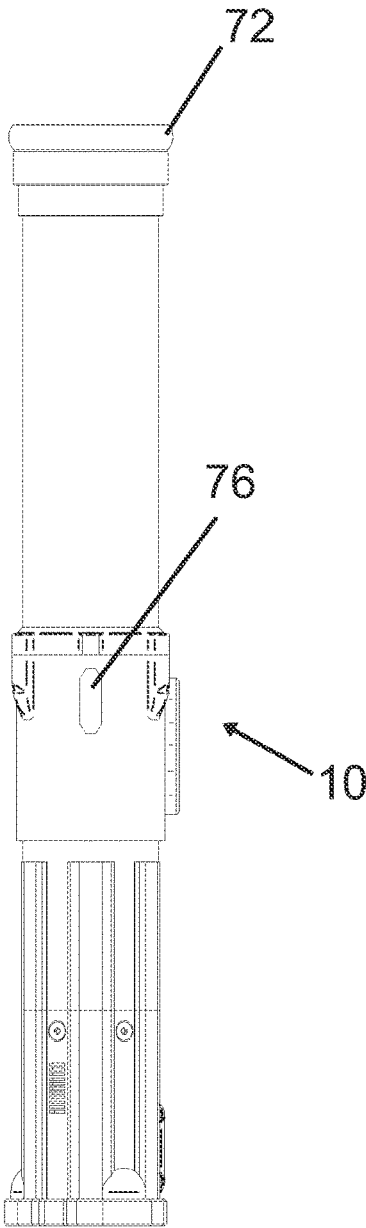
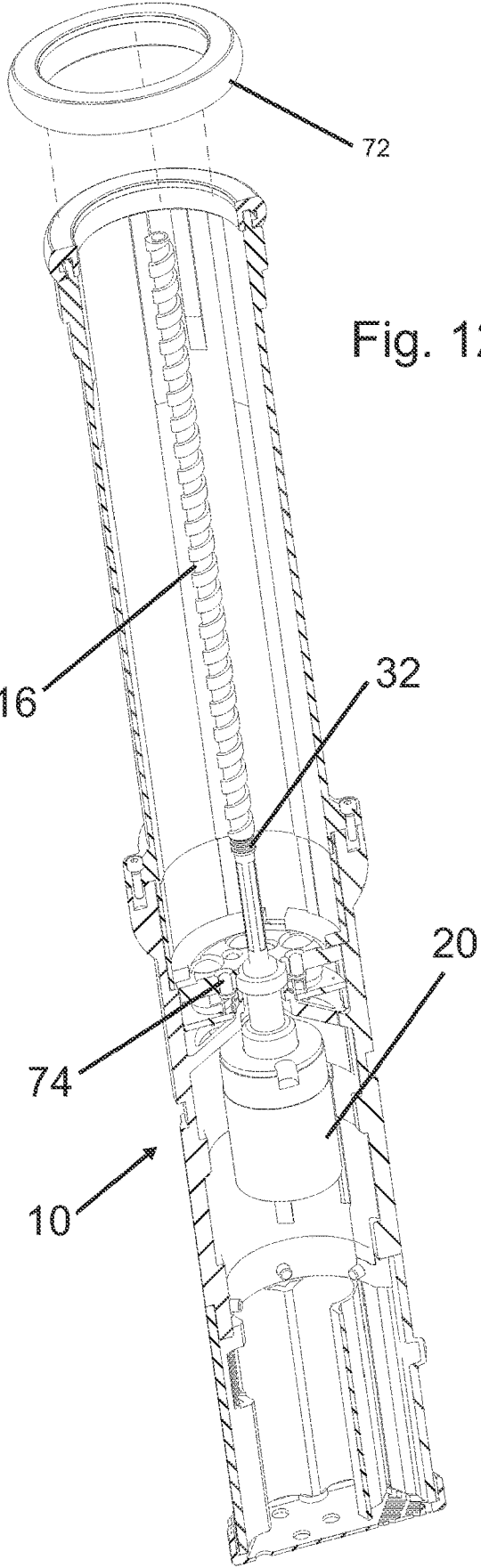

Fig. 12A



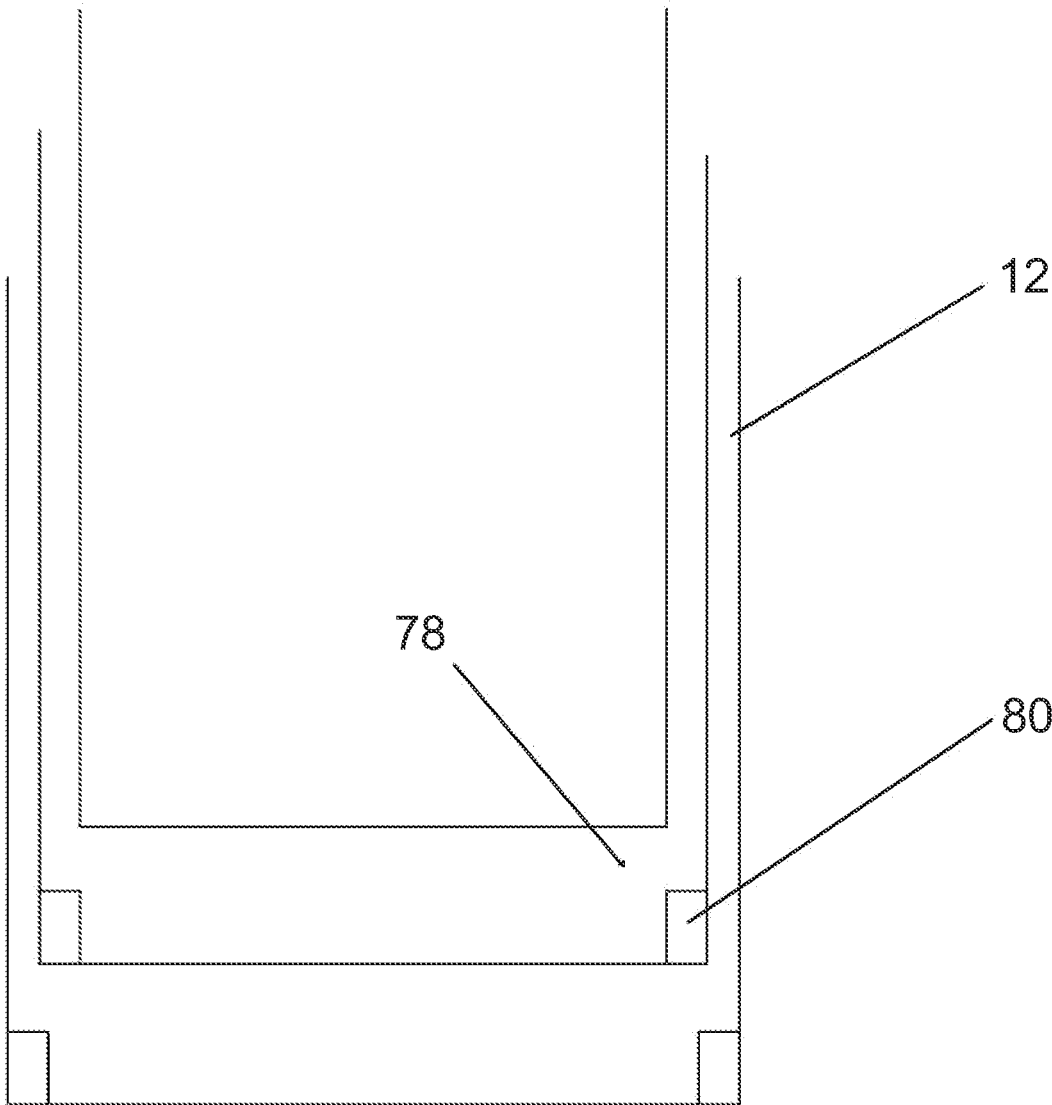

Fig. 13A



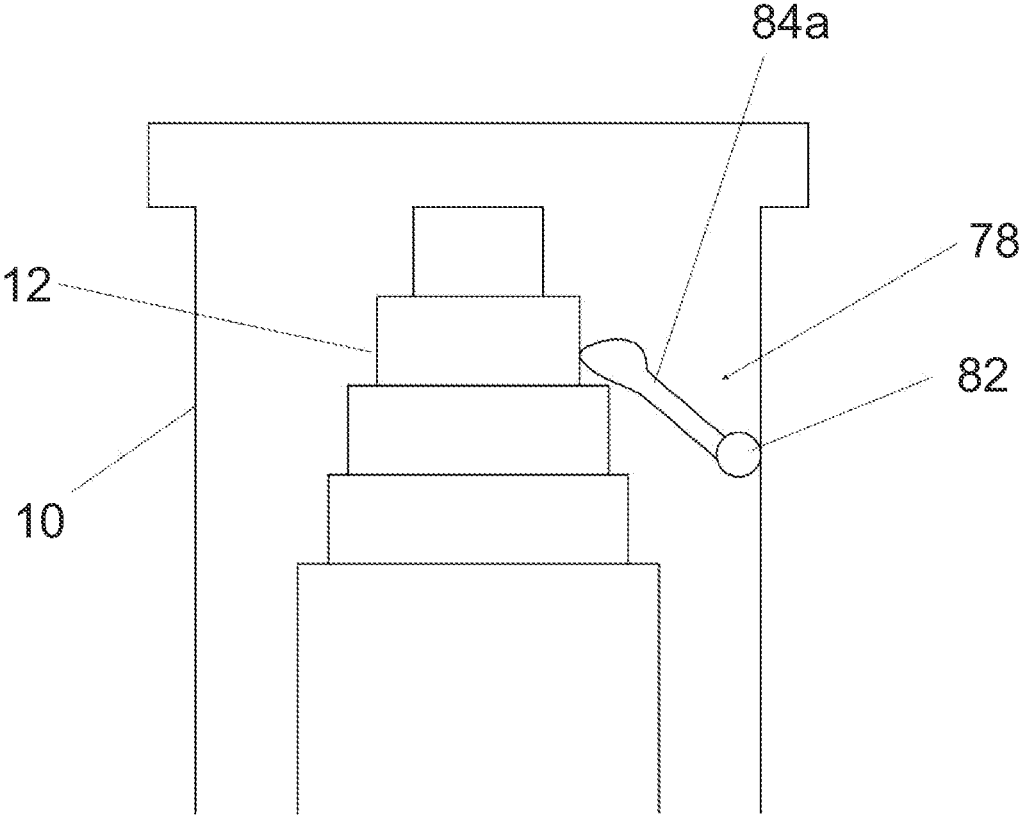

Fig. 13B

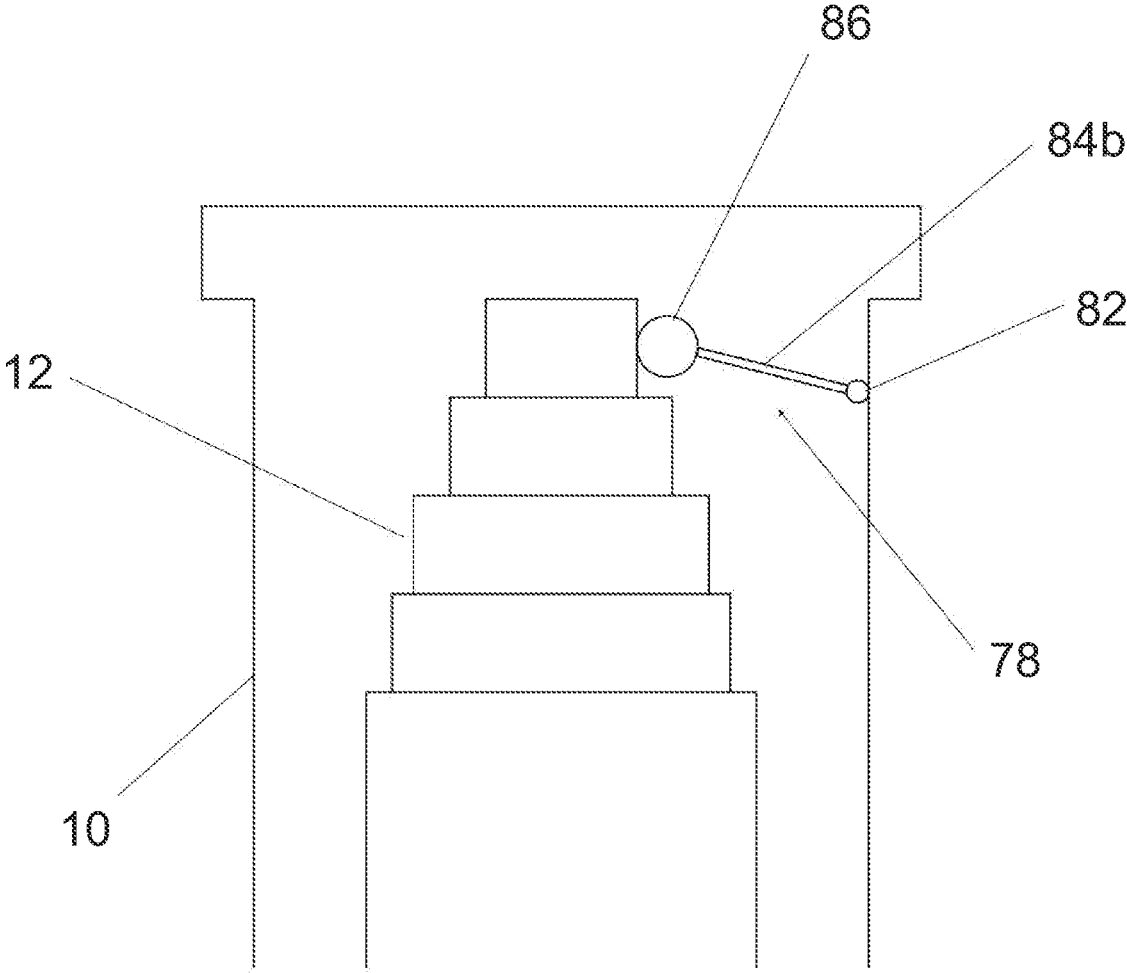

Fig. 13C

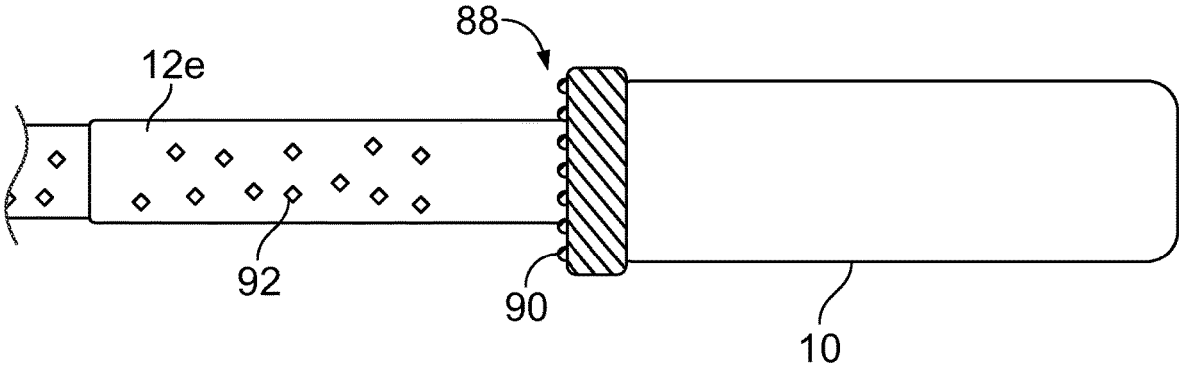

Fig. 14A

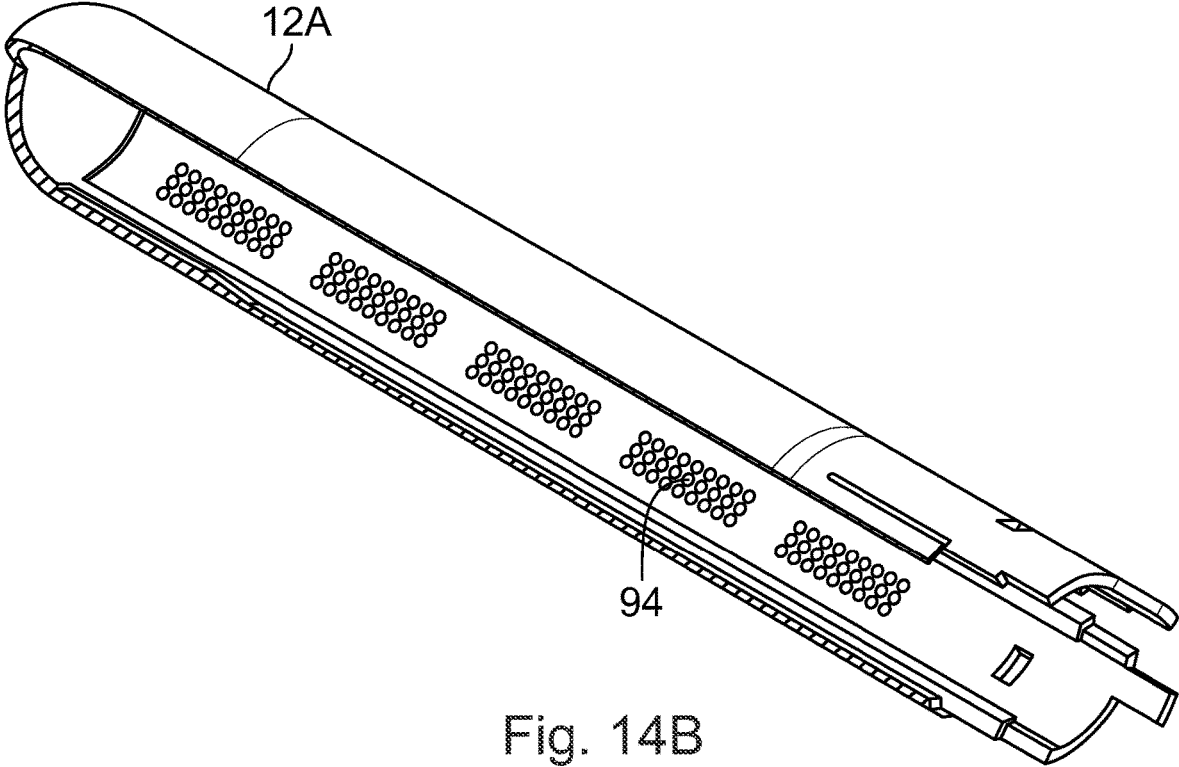

Fig. 14B

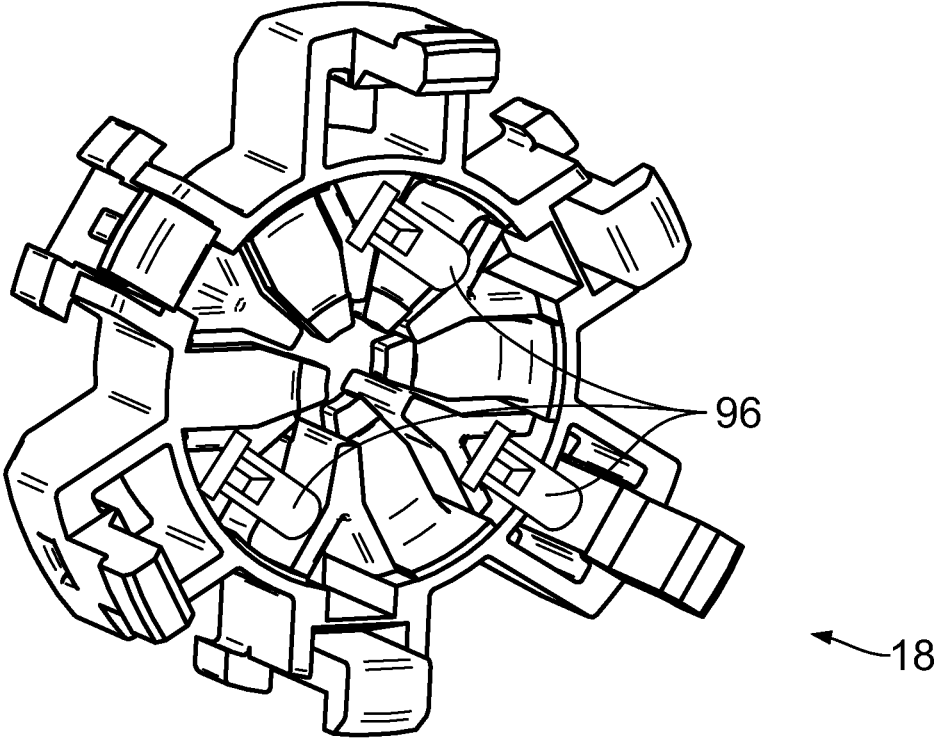

Fig. 14C

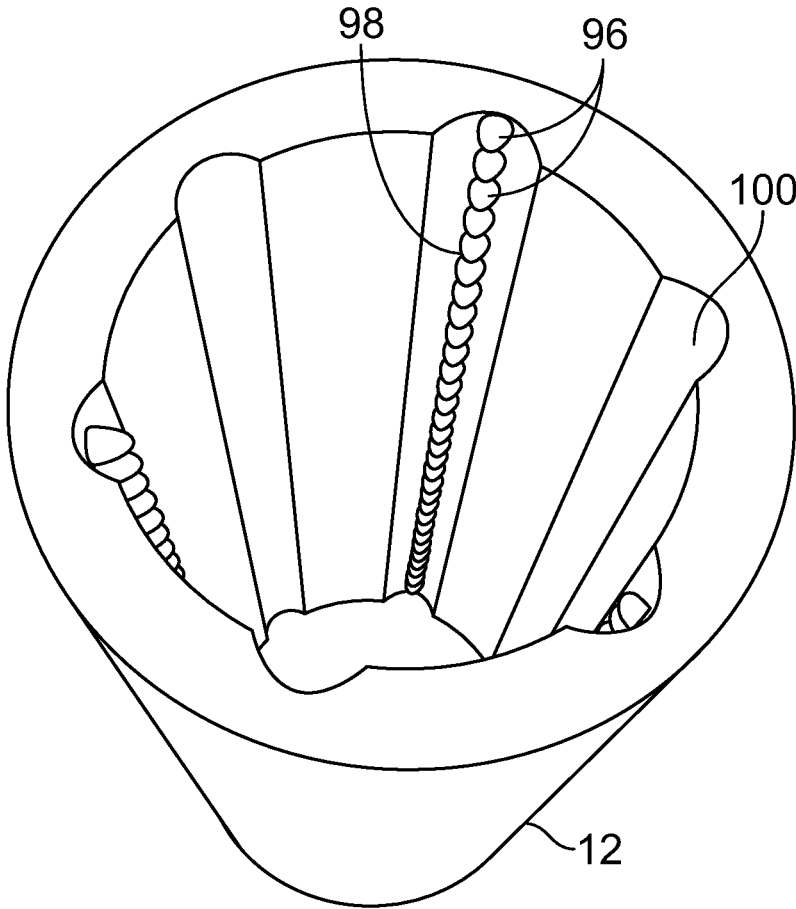

Fig. 14D

1

## TELESCOPIC ITEM AND MECHANISM THEREFOR

### FIELD OF THE INVENTION

The present invention relates to a telescopic mechanism for extending telescopic segments, in particular a telescopic segment extension and retraction mechanism configured to extend and retract segments (i.e. sleeve-like sequential segments).

### BACKGROUND OF THE INVENTION

Toy swords are popular toys with a large market. A telescoping feature can add to the enjoyment.

Examples of toy swords or sabers with a telescoping feature are disclosed in U.S. Pat. No. 7,611,398 (Hasbro Inc., 2009 Nov. 3) and U.S. Pat. No. 10,500,518 (Graves, 2019 Dec. 10); and a telescoping mechanism for a camera support is also disclosed in U.S. Pat. No. 7,684,694 (Fromm; 2010 Mar. 23).

### SUMMARY OF THE INVENTION

The present invention relates to a telescopic item and mechanism therefor. The telescopic item may be constituted by a toy sword, or constituted by or incorporated in several other products.

According to one aspect of the present invention there is provided a telescopic mechanism for a toy sword or the like. The mechanism includes a plurality of hollow telescopic blade segments having at least a proximal and a distal blade segment. The mechanism also includes a threaded spindle having spindle threads, disposed within the telescopic blade segments; a plurality of nuts configured to correspond to and interface with the spindle; and a power mechanism configured to spin the spindle. Each of the nuts respectively interfaces at the proximal portion of each of the hollow blade segments and the nuts have nut threads corresponding to the spindle threads. The nut threads are suitably sturdy whereby the nuts will move back and forth over the spindle threads when the spindle is rotated, but the nut threads are flexible and resilient enough whereby the nut threads will slide over the spindle threads if the distal telescopic blade segment is pushed above a given or predetermined threshold force into a suitably rigid body or object in order to allow any extended blade segments to retract.

The nut threads may include teeth. The teeth may be disposed at different heights or levels around respective nuts in a spiral staircase-like manner. The nuts may include teeth side supports disposed at the sides of the teeth. The nut threads may be constituted by upwardly extending petal-like projections having ridges for engaging with the spindle thread. The teeth side supports may be Y-shaped.

The nuts may be configured to be attachable to respective proximal ends of the blade segments. The nuts may be attachable to respective proximal ends of the blade segments via one or more segment-connection elements.

One or more segment-connection elements may include shoulders configured to snap into corresponding spaced apart apertures or cut-outs at the proximal ends of the respective blade segments.

The nuts may include one or more nut-to-segment friction members having a resilient arm with an outwardly facing shoulder to provide a finite but minimal friction resistance with the blade segments to prevent the blade segments from spontaneously retracting until desired.

2

The nut threads may include a flexible and resilient central annular element. The nut threads may include a flexible and resilient strip. The nut threads may include a flexible and resilient spiral member. The nut threads may include a wine-glass shaped resilient spindle-thread interface element. The nut threads may include petal-like projections having ridges.

The blade segments may have an outwardly facing step at their proximal ends and a corresponding inwardly facing shoulder at their distal ends, or vice versa, to prevent the blade segments from detaching from each other during extension.

The spindle may include a nut/segment-brake mechanism or a segment extension restraining mechanism to prevent the blade segments from detaching from each other. The nut/segment-brake mechanism or the segment extension restraining mechanism may be configured to prevent each blade segment from extending until a previously extended blade segment has fully extended. The nut/segment-brake mechanism or the segment extension restraining mechanism may include a brake ring. The nut/segment-brake mechanism or the segment extension restraining mechanism may include one or more friction elements disposed in the proximal interior end of the blade segments. The nut/segment-brake mechanism or the segment extension restraining mechanism may include a restraining lever whose proximal end is attached to a hilt of the sword. The nut/segment-brake mechanism or the segment extension restraining mechanism may include a restraining lever that includes a rotatable wheel at its distal end.

The blade segments may have one of a tapered cylindrical shape; a tapering square profile; a tapering square profile; a tapering rectangular profile; a tapering elliptical profile; and a tapering polygonal profile.

The sword may include a segment holder. The power mechanism may include a motor and a power source. The power mechanism may include a manually powered mechanism.

The mechanism may include a blade segment extension stopper including outwardly facing steps at the proximal ends of the blade segments corresponding to inwardly facing shoulders at the distal ends of the blade segments, or vice versa, whereby the blade segments are stopped after being extended to their predetermined full extent.

The blade segments may include a segment spin-prevention mechanism to prevent the blade segments from spinning. The segment spin-prevention mechanism may include an elongated groove in one side of each segment and a corresponding rail in the other side of an adjacent segment. The segment spin-prevention mechanism may include through-holes in the nuts through which corresponding rods pass through.

The sword may include an illumination device. The illumination device may include light bulbs or LEDs at the top of the hilt of the sword, whereby outer portions of the blade segments are illuminated. The illumination device may include one or more of the flexible nuts, which include one or more illumination elements configured to light up the blade segments, each blade segment having an electrical conductor from a power source. The illumination device may include piercings in the segments to allow light to shine there-through. The illumination device may include one or more illumination windows.

At least one of the nuts may be made of a transparent or translucent material.

Thus, the invention provides a telescopic mechanism for extending telescopic segments, in particular a telescopic

segment extension and retraction mechanism configured to extend and retract segments (i.e. sleeve-like sequential segments).

The telescopic mechanism can be implemented in a variety of applications, for example: a toy sword; a retrieval arm; a pointer; a tree-branch saw cutter; a fishing rod; a “selfie” camera-stick; tri-pod legs; an antennae; novelty items (e.g. extending horns on a hat); a parking lot gate or other such gates (opening/extending and retracting); telescopes and binoculars; vacuum cleaner tubes; microphone handles; tools, such as screw drivers; and so forth.

For convenience, the extension/retraction mechanism will be described in connection to a toy sword with a telescopic blade (telescopic blade segments), however it should be understood that the mechanism can be implemented in the aforementioned applications, *mutatis mutandis*. The terms “blades” and “segments”, and their derivatives including “blade segments”, may be used interchangeably herein the specification and claims.

It is a particular feature of the present telescopic mechanism that it includes a specially designed nut as part of the extension/retraction mechanism. The nut has a flexible and resilient thread mechanism that allows a correspondingly threaded spindle to engage the nut thread mechanism with enough rigidity so that the nut will be driven by the threaded spindle when the spindle is rotated (such as when the sword is being extended) and yet the flexible/resilient nut threads will slide over the threads of the spindle above a given (threshold) force (such as when the extended sword is pressed into a rigid or semi-rigid body, for example a person, thereby providing a safety feature).

In this regard, the flexible nut threads also allow for each nut to re-engage with the spindle when the sword is collapsed (retracted), in particular, suddenly collapsed, which can occur for example by a person pulling out (extending) and pushing on (retracting/collapsing) the sword blade segments. The opening defined by the teeth (nut opening) can become larger due to the flexibility of the teeth, whereby the nut can slide back down on the threaded spindle (and then the teeth can close back to its original non-flexed dimension).

The flexible nuts also help the sword blade segments retract quickly and allow the segments to move on the spindle because, being flexible, they can suit themselves to various situations (i.e. if the nut is at a slight angle or not completely centered) during extension and retraction. For example, during retraction, the flexible nuts (in particular, flexible threads thereof) can quickly pass over the spindle.

It is a particular feature of the present telescopic mechanism that it includes a blade segment extension stopper (e.g. outwardly facing step and corresponding inwardly facing shoulder on adjacent segments). As such, the segments are stopped after being extended to their predetermined full extent without requiring a friction stop between blade segments, as is common in conical telescopic swords.

One potential advantage of this feature is that the telescopic segments are not rigidly held in an extended position whereby if the sword is pressed into a surface or object the extended segments will not provide a strong poking force and may even retract from pressure. As such, the sword can include the attractive feature of being automatically extended and retracted, without undue safety concern. Further, manual retraction or extension of the sword blade segments will not destroy the extension/retraction mechanism (due to its flexible/resilient nature), nor will the extension/retraction mechanism be compromised by retraction/

collapse of the blade segments due to exceeding the aforementioned poking force.

It is another particular feature of the present invention that due to its configuration, the sword blade (blade segments) can be swapped out for another blade (blade segments).

#### BRIEF DESCRIPTION OF THE DRAWINGS

The invention may be more clearly understood upon reading of the following detailed description of non-limiting exemplary embodiments thereof, with reference to the following drawings, in which:

FIG. 1 is a perspective view of a telescopic item and mechanism therefor, in accordance with embodiments of the present invention.

FIG. 2 is a cut-away view of FIG. 1.

FIG. 3 is a perspective cut-away view of the telescopic item and mechanism showing a power source therefor, in accordance with embodiments of the present invention.

FIGS. 4, 5A and 5B are perspective views of a spindle and nut of the telescopic item and mechanism, including an enlargement, in accordance with embodiments of the present invention.

FIGS. 6A and 6B are perspective cut away views illustrating the telescopic item and mechanism in an extended position, including an enlargement thereof, in accordance with embodiments of the present invention.

FIG. 7 is a perspective view of a segment spin-prevention mechanism, in accordance with embodiments of the present invention.

FIGS. 8A-8E are various views of the nut of the telescopic item and mechanism, in accordance with embodiments of the present invention.

FIGS. 9A-9E are top views of various exemplary configurations of the nut of the telescopic item and mechanism, in accordance with embodiments of the present invention.

FIGS. 10A and 10B are side views of the telescopic item, in accordance with embodiments of the present invention.

FIG. 11 is a top view of another exemplary configuration of the nut of the telescopic item and mechanism, in accordance with embodiments of the present invention.

FIGS. 12A and 12B are perspective and side views, respectively, of the present invention showing additional exemplary embodiments.

FIGS. 13A-13C are internal side views depicting exemplary segment extension restraining mechanisms of the present invention, in accordance with embodiments thereof.

FIGS. 14A-14D are various views depicting exemplary embodiments of an illumination device of the present invention.

The following detailed description of embodiments of the invention refers to the accompanying drawings referred to above. Dimensions of components and features shown in the figures are chosen for convenience or clarity of presentation and are not necessarily shown to scale. Wherever possible, the same reference numbers will be used throughout the drawings and the following description to refer to the same and like parts.

#### DESCRIPTION OF EMBODIMENTS OF THE INVENTION

Identical, duplicate, equivalent or similar structures, elements, or parts that appear in more than one drawing are generally labeled with the same reference numeral, optionally with an additional letter or letters for reference to particular objects. Dimensions of components and features



shown in the figures are chosen for convenience or clarity of presentation and are not necessarily shown to scale or true perspective. For convenience of clarity, some elements or structures may not be shown or shown only partially or with different or without perspective, and duplicate or equivalent or similar parts may not be repeatedly labeled and/or described.

The following description relates to one or more non-limiting examples of embodiments of the invention. The invention is not limited by the described embodiments or drawings, and may be practiced in various manners. The terminology used herein should not be understood as limiting unless otherwise specified.

The figures show a toy sword of the telescopic type, in accordance with embodiments of the present invention. With reference to FIGS. 1-3, 10A and 10B the sword includes a hilt 10; a telescopic segmented hollow sword blade 12—for example with five hollow blade segments 12a, 12b, 12c, 12d, and 12e; and a telescopic mechanism 14 that effects extension and retraction of the blade. Telescopic mechanism 14 includes a threaded rod or spindle 16 that passes through the longitudinal axis of the blade 12; and a plurality of flexible/resilient nuts 18 (individually designated 18a, 18b, 18c, 18d, and 18e—each nut respectively interfacing at the proximal portion of each hollow blade segment 12a-12e of blade 12). The nuts 18a-18d have threads corresponding to those of the spindle, and which will be described in more detail herein-below. Nuts 18a-18e are dimensioned, in particular their diameters/circumferences, in a series of sizes (FIGS. 2 and 3) corresponding to the inner diameters of the sequentially sized blade segments 12a-12e. In the embodiments shown in the figures, segments 12a-12e are illustrated as cylindrical (having a circular profile/cross-section), however, they can be tapered (slightly conical) or have a square profile or other profiles such as triangular, rectangular, elliptical or polygonal, etc.

Telescopic mechanism 14 is activated by a motor 20 (FIG. 3), which is powered by a power source 22, such as one or more batteries, and operated by one or more actuator buttons 24 (FIG. 3). Alternatively, telescopic mechanism 14 can be powered mechanically, for example, by a spring mechanism (not shown) or the like. Spindle 16 can be coupled to motor 20 via a coupling 26 (FIG. 3).

FIGS. 4, 5A-5B and 8A-8E show embodiments of one of the nuts 18 on spindle 16 including an enlarged view wherein the nut threads are constituted by a plurality of spindle-thread interfaces such as inwardly projecting teeth 28. Teeth 28 are configured with a/some combination of material, dimensions (length, thickness and width) and end shape such that the teeth are sturdy or rigid enough so that nuts 18 will move back and forth (up and down) on spindle 16 (in particular, the spindle's thread 30) when the spindle is rotated, but also wherein the teeth are flexible and resilient so that the teeth will slide over the spindle's thread if the end of blade 12 is pushed into a significantly rigid body (e.g. a person or a wall). Teeth 28 are preferably disposed at different heights or levels around the nut, in a spiral staircase-like manner (FIGS. 5A-5B), although they need not be so arranged.

FIGS. 5A-5B further show that, in preferable embodiments, spindle 16 has a nut/segment-brake mechanism 32 (aka a segment extension restraining mechanism), exemplified by one or more brake rings 32 (but could alternatively be constituted by an alternately designed brake components (for example as illustrated in FIGS. 13A-13C) or an L-shaped or finger-shaped arm, or an annular outward ring at the proximal end of the segments, not shown, or the like).

In some embodiments, the aforementioned brake component, or equivalent, is mounted on the outside of hilt 10 and is configured to interact with the segments 12 so that the segments will extend sequentially. This nut/segment-brake mechanism 32 prevents each segment 12 from extending until the sequentially smaller segment has fully extended, at which point, the subsequent nut 18 is pulled with enough force so that the subsequent nut slides over the brake mechanism. However, alternatively, if motor 20 provides sufficient thrust, the segments 12 can extend at once because of their momentum.

Nuts 18a-18e can be attached to the respective proximal ends of blade segments 12a-12e in any suitable manner, including, via welding; a threaded connection; adhesives; or even integrally molded in a one-piece configuration. An exemplary manner shown in FIG. 1 of attaching nuts 18a-18e to blade segments 12a-12e is by way of one or more segment-connection elements 34, for example, that securely snap via shoulders 35 into corresponding spaced apart apertures or cut-outs 36 at the proximal ends of respective blade segments.

Best seen in the enlargement in FIG. 5B, in some embodiments, nuts 18 include one or more nut-to-segment friction members 38 having a resilient arm 40 with an outwardly facing shoulder 42 to provide a finite but minimal friction resistance with the segments 12 to prevent the segments from spontaneously retracting until desired. This resistance is preferably minimal so that the segments 12 will retract above a relatively low threshold force, for safety reasons, e.g., if the sword is stuck hard into a child's body. FIGS. 6A and 6B shows an embodiment wherein blade segments 12a-12e are cylindrical (i.e. have a circular cross-section). To prevent segments 12 from detaching from each other during extension, segments 12a-12d may have a blade segment extension stopper including an outwardly facing step 44 (e.g. annular) at their proximal ends; and segments 12b-12e have a corresponding inwardly facing shoulder 46 at their distal ends (or vice versa).

The distal ends of segments 12 may have a slightly smaller inner diameter than their proximal ends whereby there is a finite but minimal friction between adjacent segments in order to hold the segments connected together more robustly. In some embodiments, the aforementioned smaller inner diameter is gradual, gradually getting smaller toward the distal ends, along the length of segments 12.

Reverting to FIG. 1, wherein the blade segments 12a-12e are cylindrical, in some embodiments, in order to help prevent the segments from spinning when motor 20 is operated and thus spindle 16 rotates, the segments have a segment spin-prevention mechanism 48, exemplified by an elongated groove 50 in one side of each segment and a corresponding rail 52 in the other side of an adjacent segment. Spin-prevention mechanism 48 prevents the segments from spinning when spindle 16 rotates during extension and retraction. Regardless, in some embodiments, the device does not include any segment spin-prevention mechanism, rather either the rotation of spindle 16 relative to the segments 12, by motor 20, is such that nuts 12 move back and forth; or, segments 12 are configured whereby there is friction between neighboring segments to mitigate or even prevent rotation thereof.

Segment spin-prevention mechanism 48 can be any suitable mechanism, and for example, may include rails or ridges 54 (FIG. 7), linear bumps, channels, and so on. It should be noted that in the cases where segments 12 do not have a circular profile, there is no need for segment spin-prevention mechanism 48.

Alternatively, segment spin-prevention mechanism **48** can be constituted by longitudinal rods (not shown), or the like, passing through corresponding through-hole(s) **56** of the nuts **18** (FIG. **8A**), or otherwise blocking rotation of the nuts.

It should be understood that nuts **18** can be configured to provide the same function by way of other mechanisms or components such as via a suitably configured coil spring (not shown) that interfaces with spindle **16** in a manner similar to teeth **28**.

In this regard, FIGS. **9A-9D** provide a number of examples of possible alternative nut configurations. A nut opening **61** indicates where spindle **16** would pass through nut **18**. FIG. **9A** shows an embodiment of nut **18** with a flexible and resilient central annular element **60** (and acting in a manner similar to teeth **28**); in some embodiments the disk is a partial disk (not shown). FIG. **9B** shows an embodiment of nut **18** with a flexible and resilient strip **62** crossing through or approximately through the center of the nut (the strip acting in a manner similar to teeth **28**). FIG. **9C** shows an embodiment of nut **18** with a flexible and resilient spiral member **64** (the member acting in a manner similar to teeth **28**), which in some embodiments the disk is a partial spiral strip (not shown). FIG. **9D** shows an embodiment of nut **18** configured with a wine-glass shaped resilient spindle-thread interface element **65** (the element acting in a manner similar to teeth **28**). FIG. **9E** shows an embodiment of nut **18** configured with resilient and generally upward extending petal-like projections **66** having ridges **68** for engaging with the spindle thread **30** (the projections acting in a manner similar to teeth **28**). FIG. **8E** shows an embodiment of one of the nuts **18** including generally upward extending projections **66**, where the nut threads are constituted by a plurality of spindle-thread interfaces such as inwardly projecting teeth **28**.

Alternatively, spindle thread **30** is made of a flexible/resilient material rather than nut **18** (e.g. teeth **28**).

In some embodiments, nut **18** allows light to pass through as a result of having openings and/or being made of a transparent or translucent material. This allows for lighting features.

FIGS. **10A** and **10B** show respective side views of the sword in a fully retracted and fully extended position.

In some embodiments (not shown), motor **20** is automatically turned off when the sword is fully extended; for example, when the final segment is extended, a switch in an electric circuit that includes the motor can turn off the motor. Similarly, in some embodiments, motor **20** is automatically turned off when the sword is fully retracted.

In some embodiments, telescopic mechanism **14** is manually operated, and thus includes a manually powered mechanism (not shown), for example, including a crank, thumb-nail, winding apparatus, or the like.

It should be understood that telescopic mechanism **14** can be used to extend and retract segments having any telescopic-able/inter-engagable profile shape, not just conical, rather segments that are cylindrical (i.e. have a circular profile), or have substantially square; rectangular; triangular; and polygon profiles, and so forth.

FIG. **11** show flexible/resilient nut **18** wherein the nut further includes teeth side supports **70** to support and/or protect teeth **28**; basically acting as lateral stabilizers. Teeth side supports **70** are located between (on the sides) of the teeth, and exemplified by Y-shaped supports. The sides of respective supports **70** are preferably very close to corresponding/opposing sides of teeth **28**. Such supports **70** can be useful in case spindle **16** goes off-center during use and

could thus (otherwise) potentially produce some side (lateral) force and damage teeth **28**. Side supports **70** limit, or may even prevent, lateral movement of teeth **28**.

FIGS. **12A-12B** show the toy sword including a segment holder **72** (FIG. **12A**) in the form of a ring, which can be an elastic ring, snap-fit ring or threaded ring(s) thusly configured to allow segments **12** to be attached and removed to hilt **10**, i.e. to be replaced. FIG. **12A** also shows optional lighting element(s) **74**, such as one or more LEDs, whose light can shine outward via one or more light openings or windows **76** (FIG. **12B**).

FIGS. **13A-13C** illustrate segment extension restraining mechanisms **78** that prevent segments **12** from prematurely extending, i.e. to ensure the segments extend sequentially, each segment in its turn; an alternative to nut/segment brake mechanism ring(s) **32** (FIGS. **5A-5B**). In FIG. **13A**, segment retaining mechanism **78** includes one or more small friction elements **80** (which could be constituted by an annular friction element) in the proximal interior end of segments **12**. However, as can be understood, no friction element(s) are required in the most distally extending segment. These friction elements **80** frictionally interface with respective subsequent segments **12** and hold those segments with a small/weak friction force, to ensure that each segment extends one after the previous (earlier extending) segment has completely extended.

FIG. **13B-13C** show alternative segment extension restraining mechanisms **78** that prevent segments **12** from prematurely extending. In FIG. **13B**, segment extension restraining mechanism **78** includes a restraining lever **84a** whose proximal end **82** is attached to hilt **10** and may include a weak biasing element or spring (not visible) that is biased to urge the lever toward the proximal end of the sword (downward in the figure). The distal end of restraining lever **84a** is configured and positioned to interface with the distal end of segments **12** (though not necessarily the initially extending segment). As such, restraining lever **84a** provides a small/weak force on segments **12**, to ensure that each segment extends one after the previous (earlier extending) segment has completely extended.

In FIG. **13C**, segment extension restraining mechanism **78** includes a restraining lever **84b** that is generally similar to that of FIG. **13B**, however lever **84b** includes a rotatable wheel **86** at its distal end. Rotatable wheel **86** may be configured so that there is friction between the wheel and lever **84b** to provide a small/weak friction force to ensure that each segment **12** extends one after the previous (earlier extending) segment has completely extended. This wheel-to-lever friction force can be an alternative to the biasing element or spring in lever **84a**.

FIGS. **14A-14D** illustrate various lighting features that can be incorporated in the sword.

FIG. **14A** shows an exterior illumination device **88** that can be installed at the top of hilt **10** (e.g. a ring of powerful bulbs or LEDs **90**) to shine up the outer part of segments **12**. The segments **12** may have slits, apertures or segment windows **92** to reflect a dazzling light around the sword and produce a kind of aura around it.

FIG. **14B** illustrates illumination device **88** including openings or piercings **94** in segments **12** to allow light to shine there-through. Piercings **94** may be produced by a molding process during production of segments **12**, which are typically made of a plastic material.

In FIG. **14C**, illumination device **88** includes one or more of the flexible nuts **18** has one or more illumination elements **96**, such as nut light-bulbs or LEDs that light up subsequent segments **12**. Each segment **12** includes an electrical con-

ductor **98** (FIG. 14D) such as a strip of electric conductive paint or electrically conductive metal to transmit electric power from power source **22**. As a result, in an extended position, the sword can shine with a bright light.

FIG. 14D illustrates illumination elements **96** (e.g. series of light bulbs or LEDs) and electrical conductor **98** (of illumination device **88**) disposed along each segment **12**. Conductor may be disposed in an elongated recess **100**. In an extended mode, the sword can thus shine with a bright light.

OPERATION (with a motorized sword): to automatically extend sword blade **12** from hilt **10**, the user activates motor **20** by pressing on extension actuator button **24**, whereby spindle **16** rotates. As a result, the first (smallest) nut **18a** rises on the spindle to extend/push the first (smallest) segment **12a** (which is positioned above nut/segment brake mechanism **32**). When segment **12a** is fully extended, it pulls on the next largest segment **12b** (outwardly facing step **44** contacts shoulder **46**), pulling the next nut **18b** over brake mechanism **32**, and nut **18b** rises on spindle **16** to extend segment **12b**, and so on.

Depending on the particular design of the actuator, sword blade **12** can be retracted by pressing another (retraction) actuator button **24** or the same button, whereby motor **20** turns spindle **16** to pull/retract segments **12**.

It should be understood that the present telescopic mechanism can be used in a retrofit manner, i.e. as part of existing segmented swords or other such telescopic components.

It should be understood that the above description is merely exemplary and that there are various embodiments of the present invention that may be devised, mutatis mutandis, and that the features described in the above-described embodiments, and those not described herein, may be used separately or in any suitable combination; and the invention can be devised in accordance with embodiments not necessarily described above.

What is claimed is:

1. A telescopic mechanism for a toy sword, the mechanism comprising:

- a plurality of hollow telescopic blade segments, comprising at least a proximal blade segment and a distal blade segment;
- a threaded spindle having spindle threads and being disposed within the telescopic blade segments;
- a plurality of nuts configured to correspond to and interface with the spindle; and
- a power mechanism configured to spin the spindle, wherein each of the nuts respectively interfaces at the proximal portion of each of the hollow blade segments and the nuts have nut threads corresponding to the spindle threads with the nut threads being suitably sturdy to allow the nuts to move back and forth over the spindle threads when the spindle is rotated, wherein the nut threads are resilient whereby the nut threads will slide over the spindle threads while the distal telescopic blade segment is pushed above a given threshold force.

2. The mechanism of claim 1, wherein the nut threads include teeth.

3. The mechanism of claim 2, wherein the teeth are disposed at different heights or levels around respective nuts, in a spiral staircase-shaped manner.

4. The mechanism of claim 2, wherein the nuts comprise teeth side supports disposed at sides of the teeth.

5. The mechanism of claim 4, wherein the teeth side supports are Y-shaped.

6. The mechanism of claim 2, wherein the nut threads are constituted by upwardly extending petal-shaped projections having ridges for engaging with the spindle thread.

7. The mechanism of claim 1, wherein the nuts are configured to be attachable to respective proximal ends of the blade segments.

8. The mechanism of claim 1, wherein the nuts are attachable to respective proximal ends of the blade segments via one or more segment-connection elements.

9. The mechanism of claim 8, wherein the one or more segment-connection elements include shoulders that are configured to snap into corresponding spaced apart apertures or cut-outs at the proximal ends of the respective blade segments.

10. The mechanism of claim 1, wherein the nuts include one or more nut-to-segment friction members having a resilient arm with an outwardly facing shoulder to provide a finite minimal friction resistance with the blade segments to prevent the blade segments from spontaneously retracting until desired.

11. The mechanism of claim 1, wherein the nut threads include a flexible and resilient central annular element.

12. The mechanism of claim 1, wherein the nut threads include a flexible and resilient strip.

13. The mechanism of claim 1, wherein the nut threads include a flexible and resilient spiral member.

14. The mechanism of claim 1, wherein the nut threads include a wine-glass shaped resilient spindle-thread interface element.

15. The mechanism of claim 1, wherein the nut threads include petal-shaped projections having ridges.

16. The mechanism of claim 1, wherein the blade segments have an outwardly facing step at their proximal ends and a corresponding inwardly facing shoulder at their distal ends, or vice versa, to prevent the blade segments from detaching from each other during extension.

17. The mechanism of claim 1, wherein the spindle comprises a nut/segment-brake mechanism or a segment extension restraining mechanism to prevent the blade segments from detaching from each other.

18. The mechanism of claim 17, wherein the nut/segment-brake mechanism or the segment extension restraining mechanism is configured to prevent each blade segment from extending until a previously extended blade segment has fully extended.

19. The mechanism of claim 17, wherein the nut/segment-brake mechanism or the segment extension restraining mechanism comprises a brake ring.

20. The mechanism of claim 17, wherein the nut/segment-brake mechanism or the segment extension restraining mechanism comprises one or more friction elements disposed in proximal interior end of the blade segments.

21. The mechanism of claim 17, wherein the nut/segment-brake mechanism or the segment extension restraining mechanism comprises a restraining lever whose proximal end is attached to a hilt of the sword.

22. The mechanism of claim 17, wherein the nut/segment-brake mechanism or the segment extension restraining mechanism comprises a restraining lever that comprises a rotatable wheel at its distal end.

23. The mechanism of claim 1, wherein the blade segments have one of a tapered cylindrical shape; a tapering square profile; a tapering rectangular profile; a tapering elliptical profile; and a tapering polygonal profile.

24. The mechanism of claim 1, wherein the sword comprises a segment holder.

11

25. The mechanism of claim 1, wherein the power mechanism comprises a motor and a power source.

26. The mechanism of claim 1, wherein the power mechanism comprises a manually powered mechanism.

27. The mechanism of claim 1, comprising a blade segment extension stopper including outwardly facing steps at the proximal ends of the blade segments corresponding to inwardly facing shoulders at the distal ends of the blade segments, or vice versa, whereby the blade segments are stopped after being extended to their predetermined full extent.

28. The mechanism of claim 1, wherein the blade segments have a segment spin-prevention mechanism to prevent the blade segments from spinning.

29. The mechanism of claim 28, wherein the segment spin-prevention mechanism comprises an elongated groove in one side of each segment and a corresponding rail in another side of an adjacent segment.

30. The mechanism of claim 28, wherein the segment spin-prevention mechanism comprises through-holes in the nuts through which corresponding rods pass through.

12

31. The mechanism of claim 1, wherein the sword comprises an illumination device.

32. The mechanism of claim 31, wherein the illumination device comprises light bulbs or LEDs at a top of a hilt of the sword, whereby outer portions of the blade segments are illuminated.

33. The mechanism of claim 31, wherein the illumination device comprises one or more of the flexible nuts, which include one or more illumination elements configured to light up the blade segments, each blade segment having an electrical conductor from a power source.

34. The mechanism of claim 31, wherein the illumination device comprises piercings in the segments to allow light to shine there-through.

35. The mechanism of claim 31, wherein the illumination device comprises one or more illumination windows.

36. The mechanism of claim 1, wherein at least one of the nuts is made of a transparent or translucent material.

\* \* \* \* \*