



US 20220166160A1

(19) **United States**

(12) **Patent Application Publication**
CHI et al.

(10) **Pub. No.: US 2022/0166160 A1**

(43) **Pub. Date: May 26, 2022**

(54) **ELECTRICAL CONNECTOR AND CONNECTOR ASSEMBLY**

Publication Classification

(71) Applicant: **LUXSHARE PRECISION INDUSTRY COMPANY LIMITED**, Shenzhen (CN)

(51) **Int. Cl.**
H01R 13/52 (2006.01)
H01R 13/502 (2006.01)
(52) **U.S. Cl.**
CPC *H01R 13/5202* (2013.01); *H01R 13/5213* (2013.01); *H01R 13/502* (2013.01)

(72) Inventors: **Hong CHI**, Shenzhen (CN); **LingLi CHANG**, Shenzhen (CN)

(57) **ABSTRACT**

(73) Assignee: **LUXSHARE PRECISION INDUSTRY COMPANY LIMITED**, Shenzhen (CN)

The present disclosure provides an electrical connector and a connector assembly. The electrical connector comprises a first sleeve, a first cover, and a sealing member. The first sleeve comprises a first mating opening and a first connecting end surface. The first connecting end surface is disposed at the periphery of the first mating opening. The first cover is disposed in the first sleeve. The first cover comprises a first mating surface exposed from the first mating opening. The sealing member is disposed on a side surface of the first cover and surrounds the first cover. The sealing member is disposed between the first sleeve and the first cover. The sealing member comprises a sealing sheet extending from the first mating surface in a direction close to the first connecting end surface of the first sleeve.

(21) Appl. No.: **17/465,450**

(22) Filed: **Sep. 2, 2021**

(30) **Foreign Application Priority Data**

Nov. 23, 2020 (CN) 202022726410.8

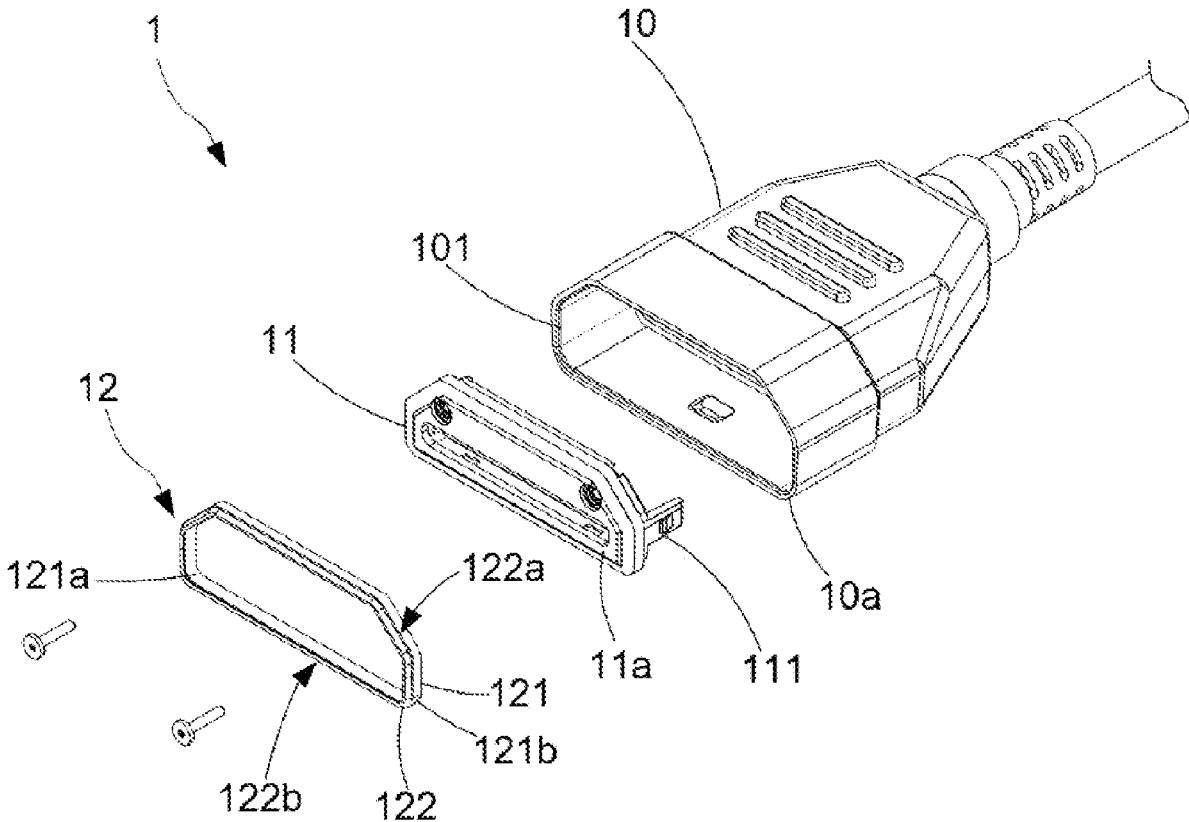

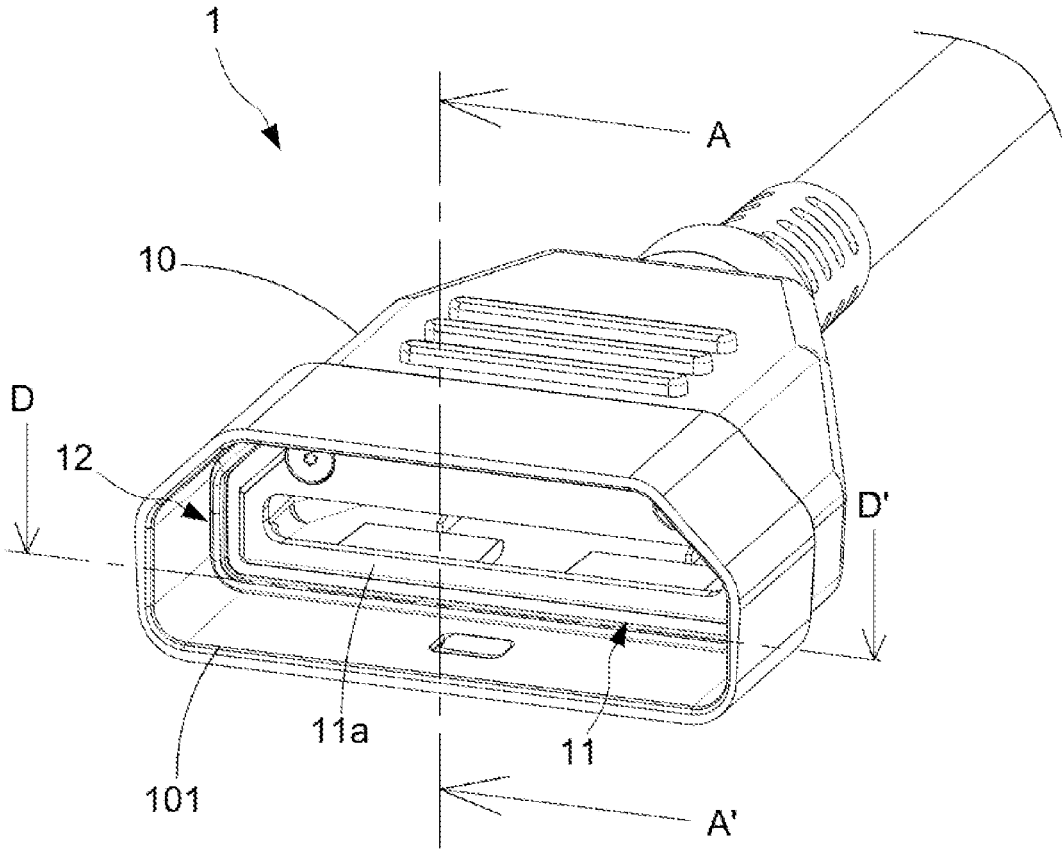

FIG. 1

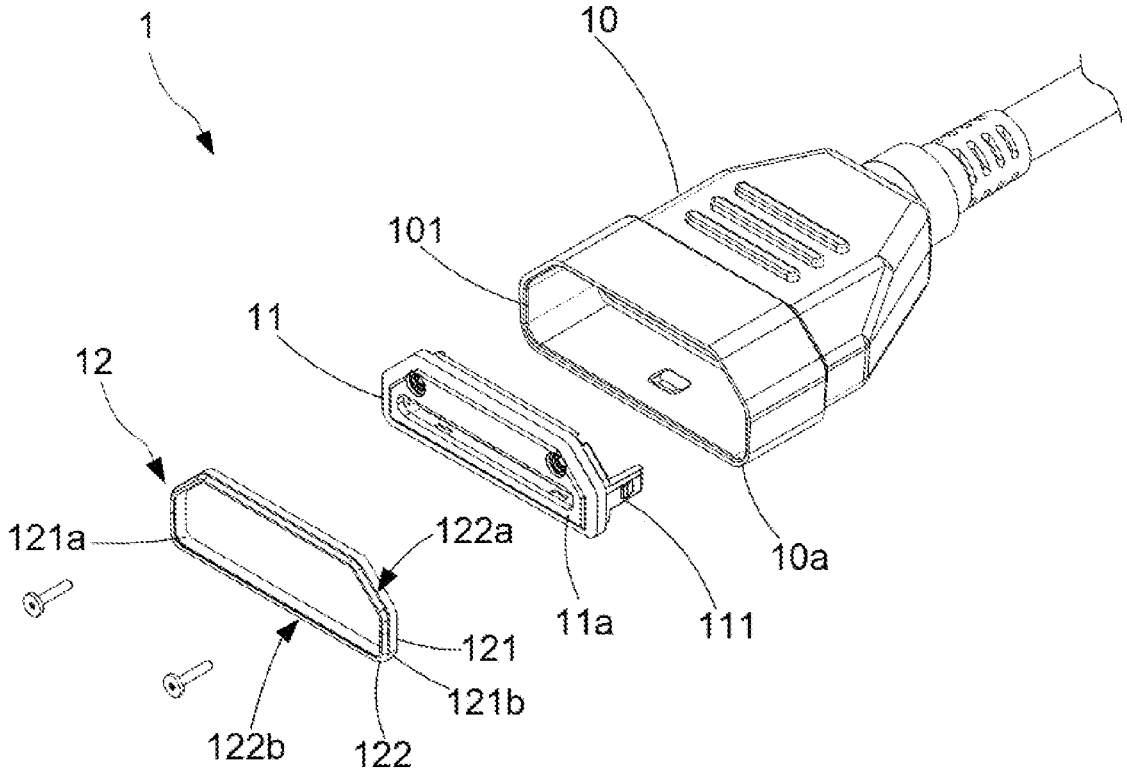

FIG. 2

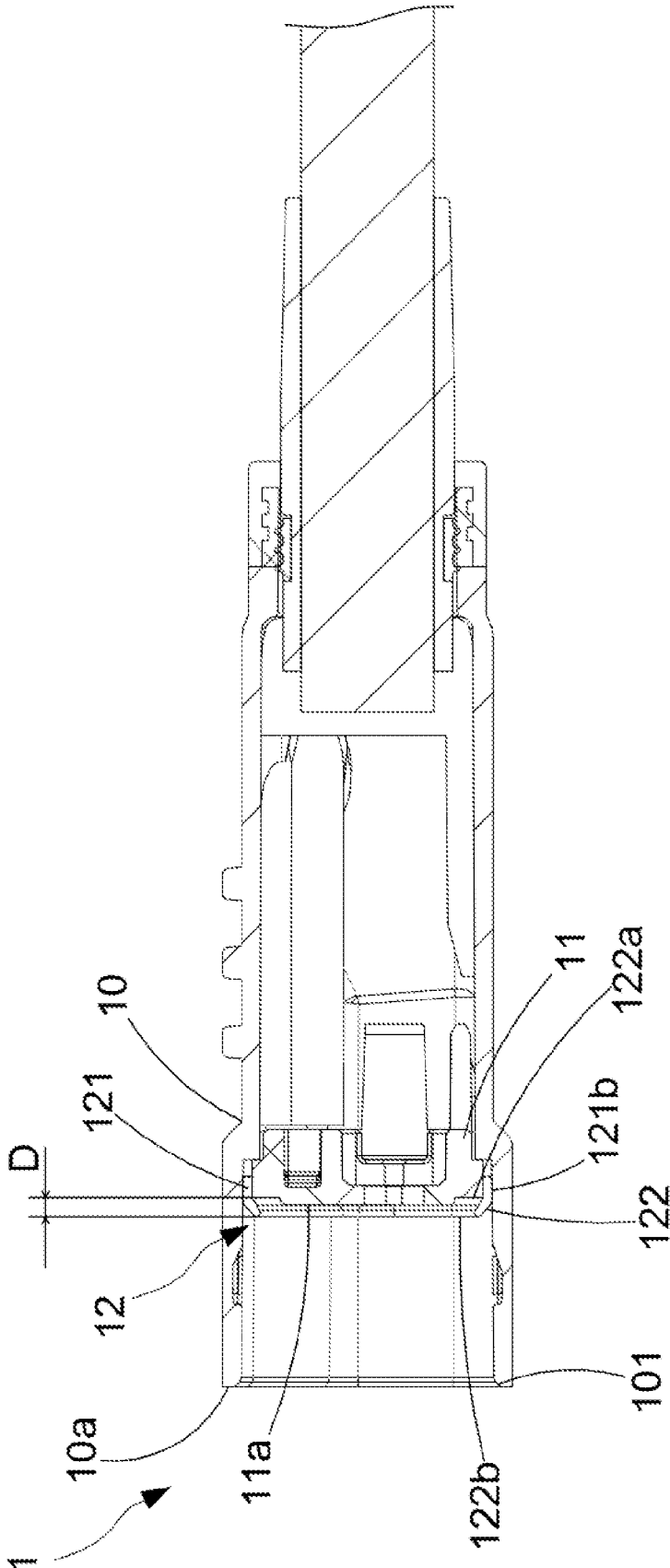

FIG. 3

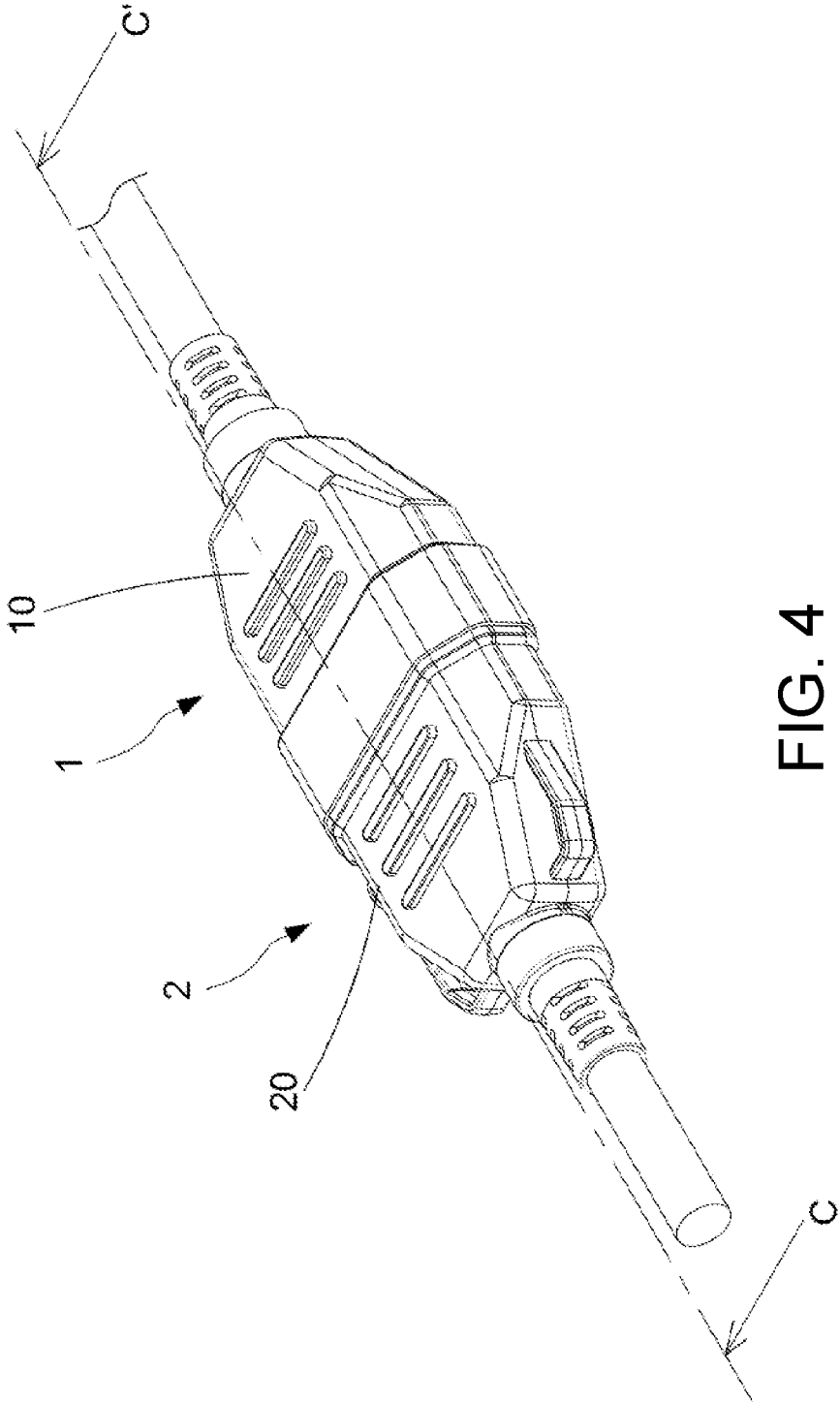

FIG. 4

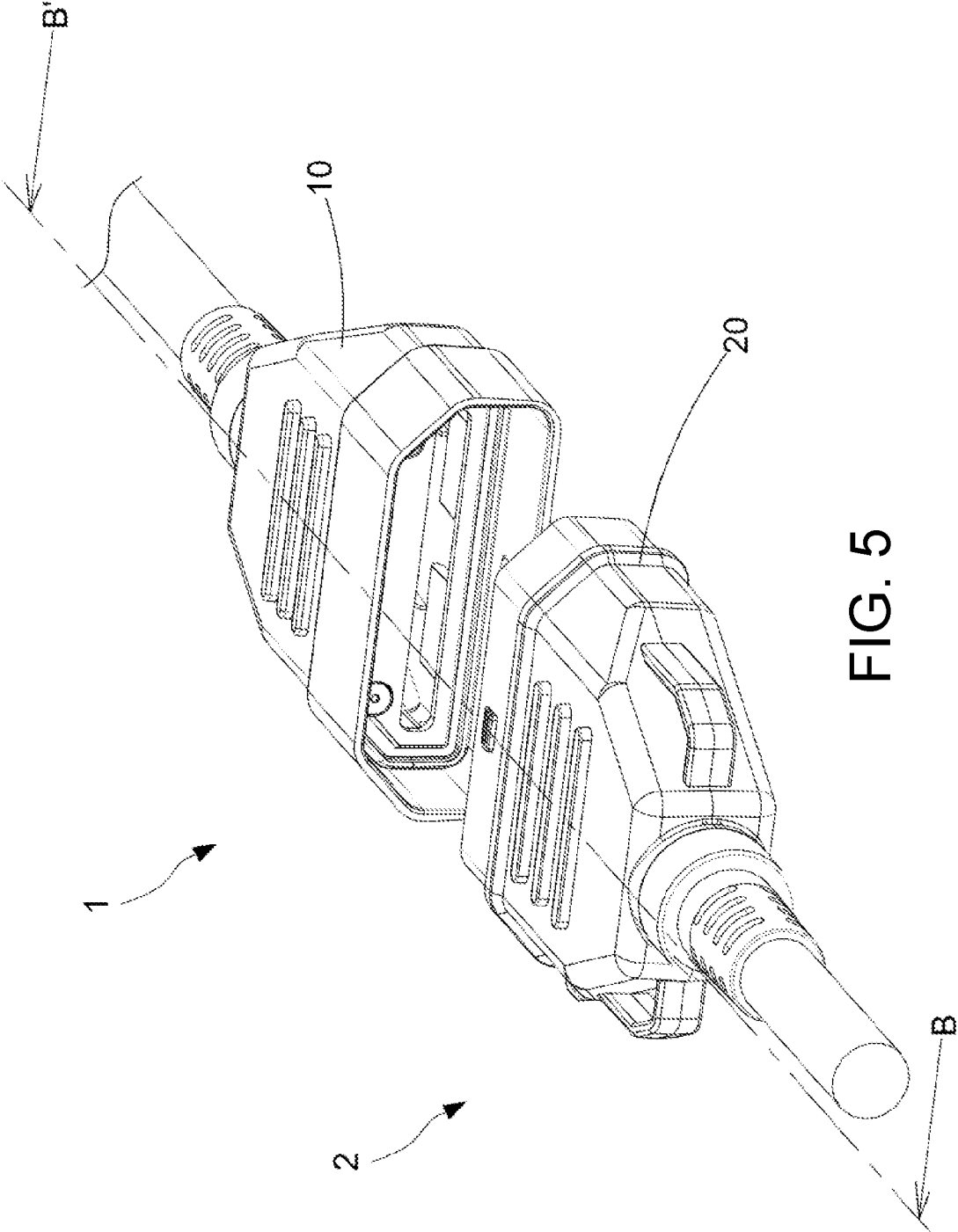

FIG. 5

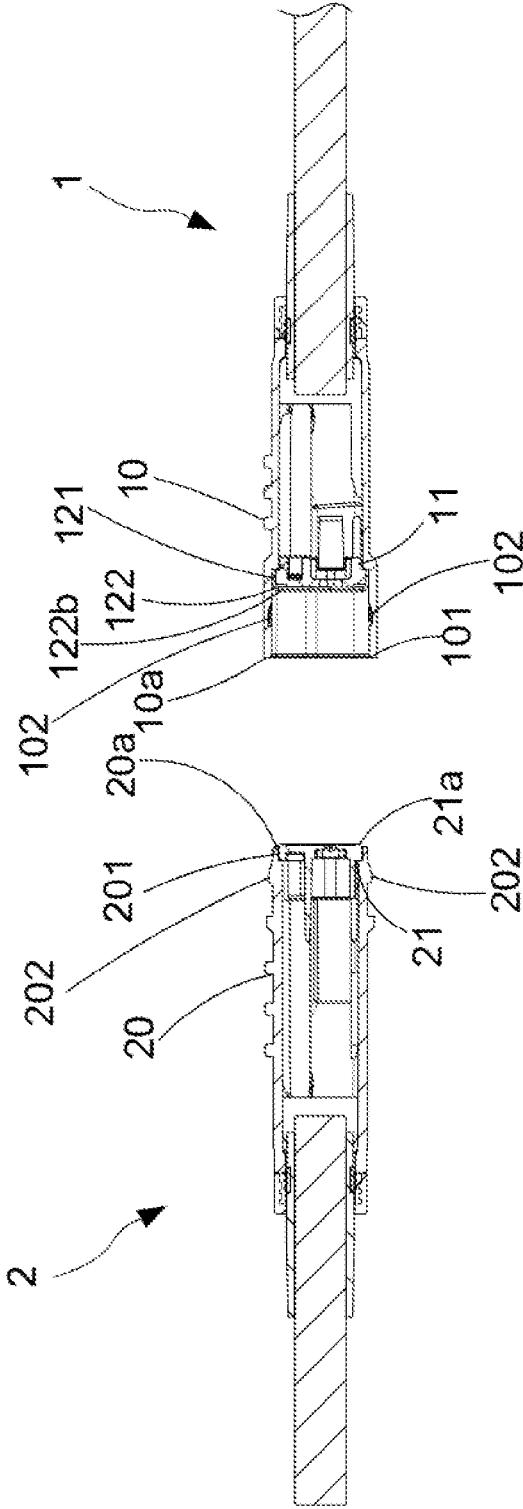

FIG. 6

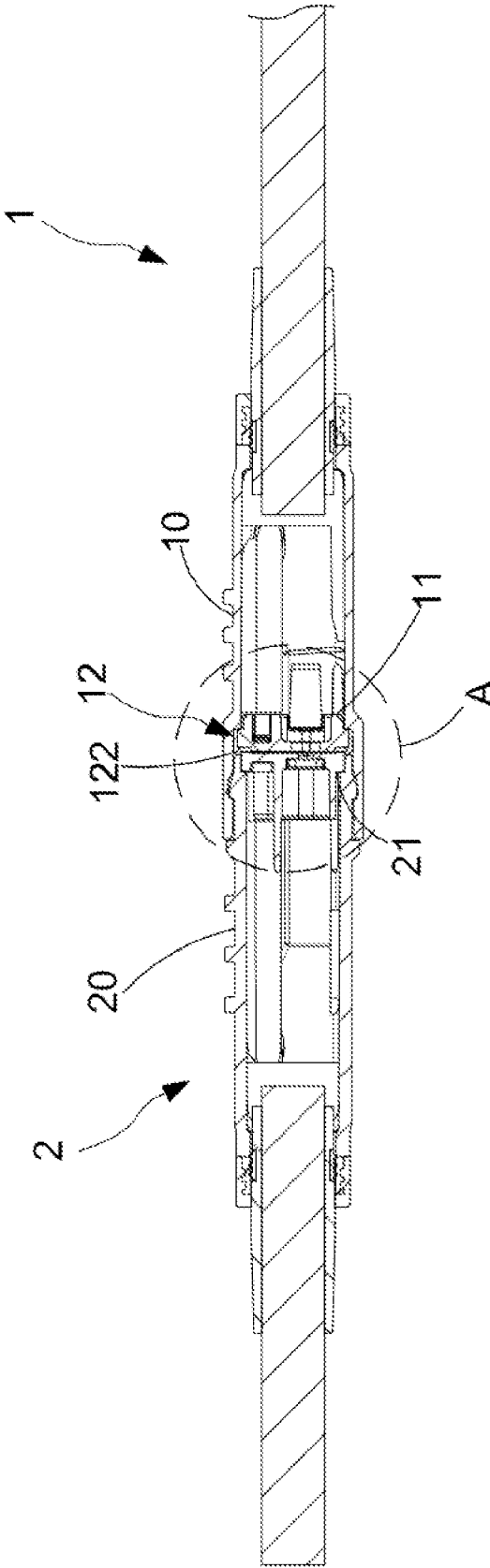

FIG. 7

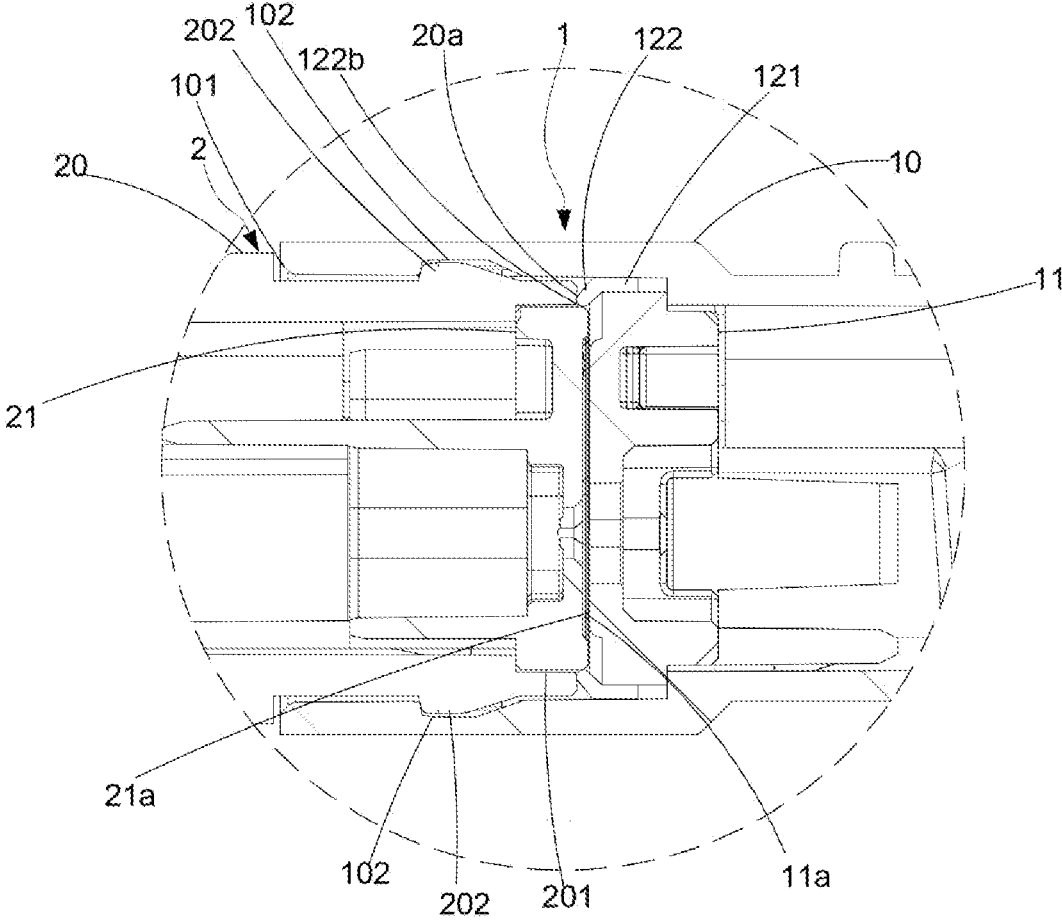

FIG. 8

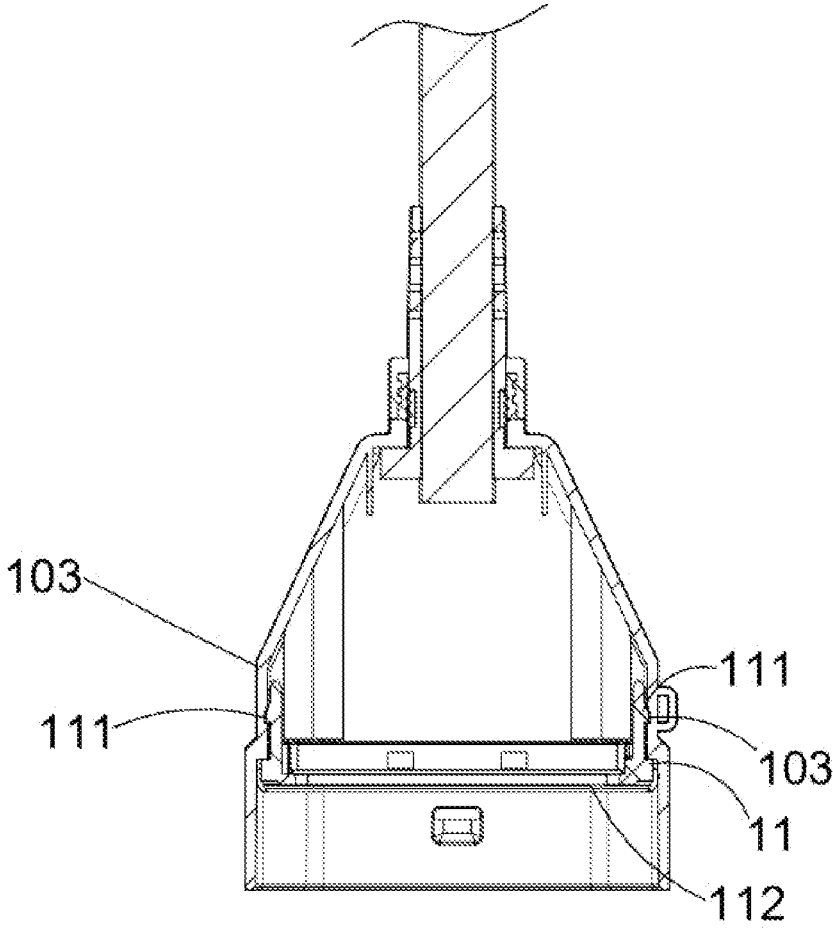

FIG. 9

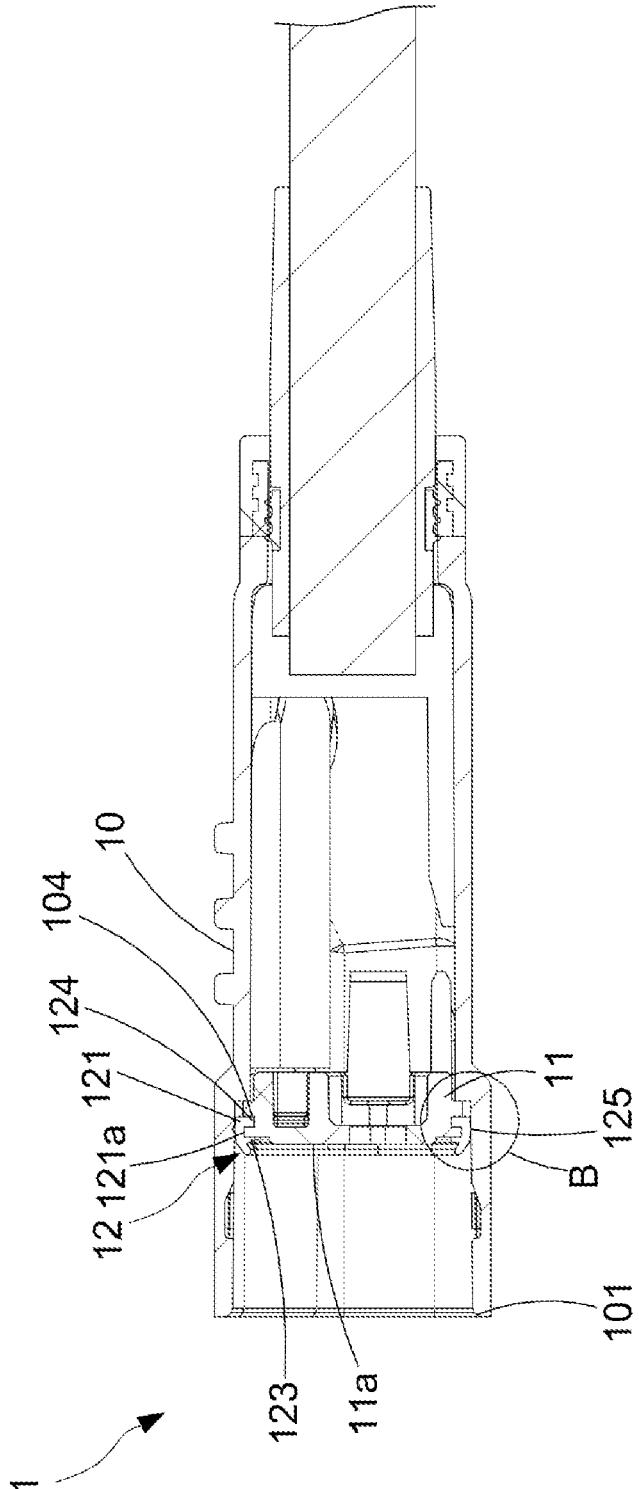

FIG. 10

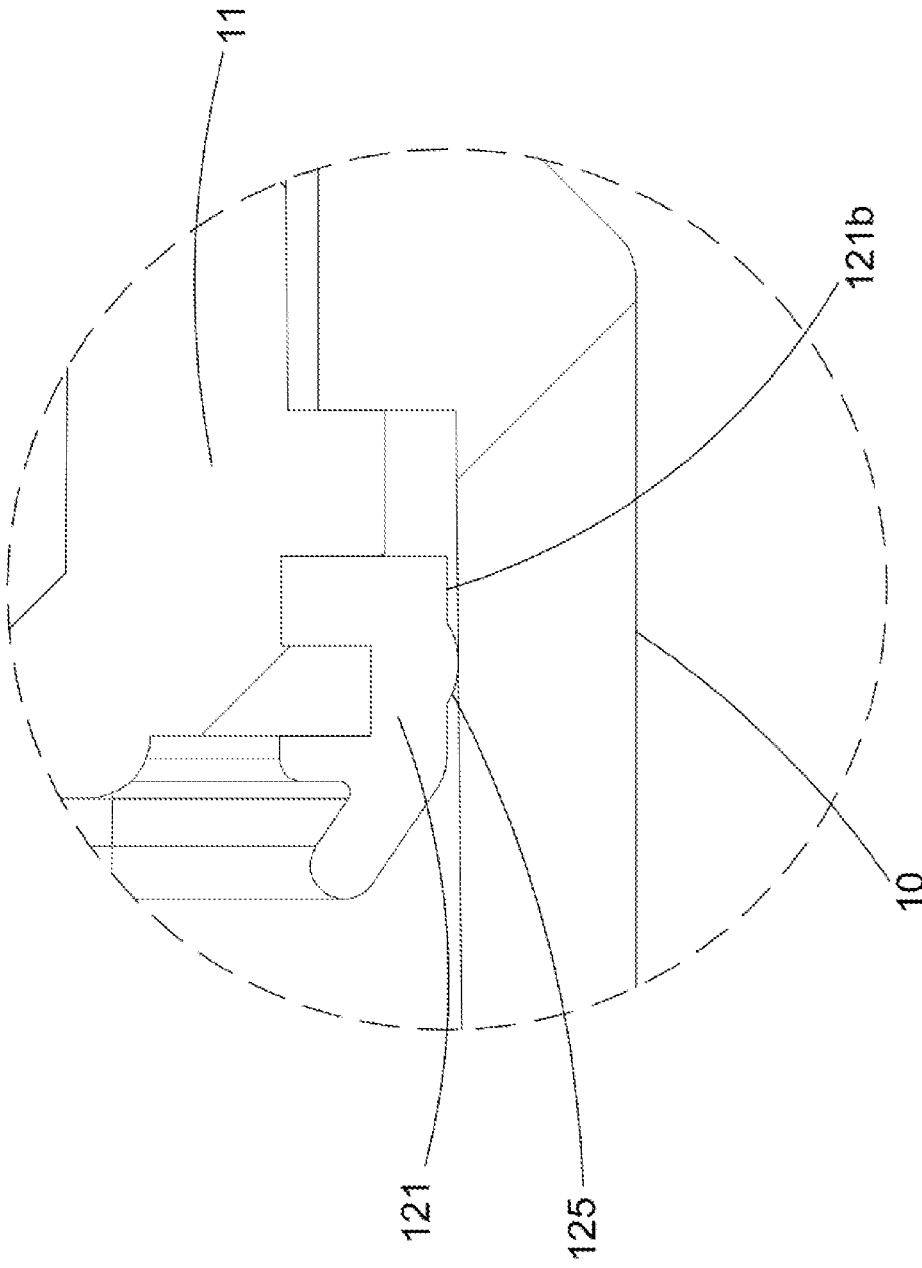

FIG. 11

ELECTRICAL CONNECTOR AND CONNECTOR ASSEMBLY

CROSS-REFERENCE TO RELATED APPLICATION

[0001] This application claims the priority benefit of Chinese Patent Application Serial Number 202022726410.8, filed on Nov. 23, 2020, the full disclosure of which is incorporated herein by reference.

BACKGROUND

Technical Field

[0002] The present disclosure relates to the technical field of connector, particularly to an electrical connector and a connector assembly.

Related Art

[0003] In conventional connectors, the joint where a male connector connects with a female connector is provided with a waterproof ring to prevent external water and moisture from entering the connector through the gap between the male connector and the female connector to keep the internal electrical components (such as circuit boards, terminals, etc.) from being corroded and damaged. The waterproof ring is usually disposed at the male connector or the female connector. When the waterproof ring is installed on the male connector, the required standard for dimensional accuracy and flatness to the male connector are more strict than to the female connector when installing on the female connector. The female connector, when connecting with the male connector, it would be pressed and interfered with the waterproof ring to achieve the effect of waterproofing. However, the waterproof ring is prone to wear and elastically fatigue due to frequent plugging and unplugging of the connectors. Thus, the waterproofing performance would be lowered, and the service life of the waterproof ring would be shortened.

SUMMARY

[0004] The embodiments of the present disclosure provide an electrical connector and a connector assembly tended to solve the problem of lowered waterproofing performance of the waterproof ring which is prone to wear and elastically fatigue due to frequent plugging and unplugging of the connectors.

[0005] In one embodiment, an electrical connector is provided, which comprises a first sleeve, a first cover, and a sealing member. The first sleeve comprises a first mating opening and a first connecting end surface. The first connecting end surface is disposed at the periphery of the first mating opening. The first cover is disposed in the first sleeve. The first cover comprises a first mating surface exposed from the first mating opening. The sealing member is disposed on a side surface of the first cover and surrounds the first cover. The sealing member is disposed between the first sleeve and the first cover. The sealing member comprises a sealing sheet extending from the first mating surface in a direction close to the first connecting end surface of the first sleeve.

[0006] In another embodiment, a connector assembly is provided, which comprises an electrical connector according to the above embodiment and a mating connector. The

mating connector comprises a second sleeve and a second cover. The second cover is disposed in the second sleeve. The second sleeve comprises a second connecting end surface. The second cover protrudes from the second connecting end surface. When the mating connector is connected with the electrical connector, one side of the sealing sheet close to the first connecting end surface is in contact with the second connecting end surface of the second sleeve and a side surface of the second cover.

[0007] In the embodiments of the present disclosure, the sealing sheet is in contact with the second connecting end surface of the second sleeve of the mating connector and the side surface of the second cover to perform waterproofing of the electrical connector, which reduces friction between the mating connector and the sealing sheet of the sealing member during plugging and unplugging to avoid wear and elastic fatigue of the sealing member. Thus, the waterproof performance of the sealing member could be maintained in excellent condition when it is used for a longer period of time, and the service life of the sealing member can be greatly increased.

[0008] It should be understood, however, that this summary may not contain all aspects and embodiments of the present disclosure, that this summary is not meant to be limiting or restrictive in any manner, and that the disclosure as disclosed herein will be understood by one of ordinary skill in the art to encompass obvious improvements and modifications thereto.

BRIEF DESCRIPTION OF THE DRAWINGS

[0009] The features of the exemplary embodiments believed to be novel and the elements and/or the steps characteristic of the exemplary embodiments are set forth with particularity in the appended claims. The Figures are for illustration purposes only and are not drawn to scale. The exemplary embodiments, both as to organization and method of operation, may best be understood by reference to the detailed description which follows taken in conjunction with the accompanying drawings in which:

[0010] FIG. 1 is a perspective view of an electrical connector of the first embodiment of the present disclosure;

[0011] FIG. 2 is an exploded view of the electrical connector of the first embodiment of the present disclosure;

[0012] FIG. 3 is a cross-sectional view along line A-A' in FIG. 1;

[0013] FIG. 4 is a perspective view of a connector assembly of the first embodiment of the present disclosure;

[0014] FIG. 5 is an exploded view of the connector assembly of the first embodiment of the present disclosure;

[0015] FIG. 6 is a cross-sectional view along line B-B' in FIG. 5;

[0016] FIG. 7 is a cross-sectional view along line C-C' in FIG. 4;

[0017] FIG. 8 is an enlarged view of area A of FIG. 7;

[0018] FIG. 9 is a cross-sectional view along line D-D' in FIG. 1;

[0019] FIG. 10 is a cross-sectional view of an electrical connector of the second embodiment of the present disclosure; and

[0020] FIG. 11 is an enlarged view of area B of FIG. 10.

DETAILED DESCRIPTION OF THE EMBODIMENTS

[0021] The present disclosure will now be described more fully hereinafter with reference to the accompanying drawings, in which exemplary embodiments of the disclosure are shown. This present disclosure may, however, be embodied in many different forms and should not be construed as limited to the embodiments set forth herein. Rather, these embodiments are provided so that this present disclosure will be thorough and complete, and will fully convey the scope of the present disclosure to those skilled in the art.

[0022] Certain terms are used throughout the description and following claims to refer to particular components. As one skilled in the art will appreciate, manufacturers may refer to a component by different names. This document does not intend to distinguish between components that differ in name but function. In the following description and in the claims, the terms “include/including” and “comprise/comprising” are used in an open-ended fashion, and thus should be interpreted as “including but not limited to”. “Substantial/substantially” means, within an acceptable error range, the person skilled in the art may solve the technical problem in a certain error range to achieve the basic technical effect.

[0023] The following description is of the best-contemplated mode of carrying out the disclosure. This description is made for the purpose of illustration of the general principles of the disclosure and should not be taken in a limiting sense. The scope of the disclosure is best determined by reference to the appended claims.

[0024] Moreover, the terms “include”, “contain”, and any variation thereof are intended to cover a non-exclusive inclusion. Therefore, a process, method, object, or device that includes a series of elements not only includes these elements, but also includes other elements not specified expressly, or may include inherent elements of the process, method, object, or device. If no more limitations are made, an element limited by “include a/an . . .” does not exclude other same elements existing in the process, the method, the article, or the device which includes the element.

[0025] FIG. 1 and FIG. 2 are perspective view and exploded view of an electrical connector of the first embodiment of the present disclosure. FIG. 3 is a cross-sectional view along line A-A' in FIG. 1. As shown in the figures, in this embodiment, the electrical connector 1 comprises a first sleeve 10, a first cover 11, and a sealing member 12. The first sleeve 10 comprises a first mating opening 101 for accommodating a connector body (not shown). The first cover 11 is disposed in the first sleeve 10 to secure the connector body in the first sleeve 10. The first cover 11 comprises a first mating surface 11a exposed from the first mating opening 101. One end of the first sleeve 10 comprising the first mating opening 101 protrudes from the first mating surface 11a. The first sleeve 10 comprises a first connecting end surface 10a disposed at the periphery of the first mating opening 101. The first connecting end surface 10a is parallel to the first mating surface 11a. A gap distance exists between the first connecting end surface 10a and the first mating surface 11a. The sealing member 12 is disposed on a side surface of the first cover 11 and surrounds the first cover 11. The sealing member 12 is disposed between the first sleeve 10 and the first cover 11. In one embodiment, the sealing member 12 is disposed on the periphery of the first mating surface 11a.

[0026] The sealing member 12 comprises a sealing body 121 and a sealing sheet 122 which are both annular-shaped. The sealing body 121 comprises an inner side edge 121a and an outer side edge 121b opposite to the inner side edge 121a. The sealing sheet 122 comprises a first side 122a and a second side 122b. The first side 122a of the sealing sheet 122 is connected with the sealing body 121. The sealing sheet 122 extends in a direction away from the sealing body 121. The sealing sheet 122 is disposed on one side of the sealing body 121. A gap distance D exists between a side edge of the second side 122b of the sealing sheet 122 and the sealing body 121. In one embodiment, the second side 122b of the sealing sheet 122 extends from the first side 122a in a direction away from the sealing body 121. The extending length of the sealing sheet 122 between the first side 122a and the second side 122b is greater than the gap distance D. So, the sealing sheet 122 of this embodiment is inclined to the sealing body 121. When the sealing member 12 is disposed on the first cover 11, the sealing body 121 would be disposed on the side surface of the first cover 11 and surrounds the first cover 11. The sealing sheet 122 extends from the first mating surface 11a in a direction toward the first connecting end surface 10a of the first sleeve 10. In this embodiment, the sealing member 12 is made of elastic material.

[0027] FIG. 4 and FIG. 5 are perspective view and exploded view of a connector assembly of the first embodiment of the present disclosure. FIG. 6 is a cross-sectional view along line B-B' in FIG. 5. As shown in the figures, the mating connector 2 connected with the electrical connector 1 comprises a second sleeve 20 and a second cover 21. The second sleeve 20 comprises a second mating opening 201 and a second connecting end surface 20a disposed at the periphery of the second mating opening 201. The second sleeve 20 accommodates a mating connector body (not shown). The second cover 21 is disposed in the second sleeve 20 and protrudes from the second connecting end surface 20a to secure the mating connector body in the second sleeve 20. The second cover 21 comprises a second mating surface 21a. A gap distance exists between the second mating surface 21a and the second connecting end surface 20a. A part of a side surface of the second cover 21 is exposed from the second sleeve 20.

[0028] FIG. 7 is a cross-sectional view along line C-C' in FIG. 4. FIG. 8 is an enlarged view of area A of FIG. 7. As shown in the figures, when the mating connector 2 is connected with the electrical connector 1, the mating connector 2 would enter the first sleeve 10 from the first mating opening 101, the second cover 21 of the mating connector 2 would pass through the sealing sheet 122, and a side edge of the second side 122b of the sealing sheet 122 would be in contact with a side surface of the second cover 21 and the second connecting end surface 20a of the second sleeve 20. When the mating connector 2 is closing to the electrical connector 1, the second mating surface 21a would be closing to the first mating surface 11a accordingly. In this way, the second connecting end surface 20a of the second sleeve 20 of the mating connector 2 would push the sealing sheet 122 to move closer to the sealing body 121 to reduce the gap distance D (see FIG. 3) between the side edge of the second side 122b of the sealing sheet 122 and the sealing body 121. Meanwhile, the side edge of the second side 122b of the sealing sheet 122 would extend toward the side surface of the second cover 21, and the side surface of the second cover

21 would compress the sealing sheet **122**, and the compressed sealing sheet **122** would generate an elastic force which would be applied to the side surface of the second cover **21**, allowing one side of the sealing sheet **122** close to the first connecting end surface **10a** to firmly abut against the side surface of the second cover **21**. In this way, external moisture can be effectively prevented from entering the gap between the first mating surface **11a** and the second mating surface **21a**. In one embodiment, the sealing sheet **122** is made of elastic material, such as but not limited to silicone. The second connecting end surface **20a** and the side surface of the second cover **21** jointly compress the sealing sheet **122**, and an elastic force generated by the compressed sealing sheet **122** would be applied to the second connecting end surface **20a** and the side surface of the second cover **21** simultaneously, allowing one side of the sealing sheet **122** close to the first connecting end surface **10a** to firmly and simultaneously abut against the second connecting end surface **20a** and the side surface of the second cover **21**. Alternatively, the second connecting end surface **20a** compresses the sealing sheet **122**, so that the sealing sheet **122** can be elastically deformed and bent toward the side surface of the second cover **21**. One side of the sealing sheet **122** close to the first connecting end surface **10a** can firmly and simultaneously abut against the second connecting end surface **20a** and the side surface of the second cover **21** through the elastic restoring force of the elastic deformation of the sealing sheet **122**. In this embodiment, the sealing member **12** is waterproof due to the contact between the sealing sheet **122** and the mating connector **2**. During the plugging and unplugging process, the mating connector **2** would not friction with the sealing member **12**, and the sealing sheet **122** of the sealing member **12** is in frontal contact with the mating connector **2** in the plugging and unplugging direction. In this way, wearing and elastic fatigue of the sealing member **12** can be avoided, keeping the sealing member **12** with excellent waterproof performance to increase the service life of the sealing member **12**.

[0029] In this embodiment, two opposite inner surfaces of the first sleeve **10** are respectively provided with a positioning groove **102**. Each of the positioning grooves **102** is disposed between the first connecting end surface **10a** of the first sleeve **10** and the first mating surface **11a** of the first cover **11**. Two opposite outer surfaces of the second sleeve **20** are respectively provided with a positioning bump **202**. Each of the positioning bumps **202** is close to one end of the second sleeve **20** comprising a second mating opening **201**. When the mating connector **2** is connected with the electrical connector **1**, the positioning bump **202** would enter the corresponding positioning groove **102** to prevent the mating connector **2** from being detached from the electrical connector **1** due to any possible accidental touch.

[0030] In this embodiment, the mating connector **2** is mated with the electrical connector **1** to form a connector assembly. The connector body of the electrical connector **1** and the mating connector body of the mating connector **2** can be a male connector and a female connector, respectively. The connector body of the electrical connector **1** and the mating connector body of the mating connector **2** are respectively connected to the outside of the connectors through a cable.

[0031] Back to FIG. 3, in this embodiment, since the outer side edge **121b** of the sealing body **121** is in contact with the inner surface of the first sleeve **10**, the sealing member **12**

can seal the gap between the inner surface of the first sleeve **10** and the side surface of the first cover **11**. In this way, external moisture can be prevented from entering the gap between the inner surface of the first sleeve **10** and the side surface of the first cover **11** to increase the waterproofness of the electrical connector **1**.

[0032] In this embodiment, the cross-sectional area of the sealing sheet **122** along a direction orthogonal to the first mating surface **11a** is an inclined surface, which can also be an arc-surface or a bent surface as long as a gap distance **D** between the second side **122b** of the sealing sheet **122** and the sealing body **121** exists, and the second side **122b** of the sealing sheet **122** extends from the first side **122a** in a direction away from the sealing body **121** for achieving the effects described above. In one embodiment, the extending direction of the sealing sheet **122** from the sealing body **121** is inclined to the direction orthogonal to the first mating surface **11a**.

[0033] FIG. 9 is a cross-sectional view along line D-D' in FIG. 1. Referring to FIG. 3 and FIG. 9, two opposite sides of the first cover **11** are respectively provided with a buckle **111**. Each of the buckles **111** is disposed on one side of the first cover **11** opposite to the first mating surface **11a** and extends in a direction away from the first mating surface **11a**. The two opposite inner surfaces of the first sleeve **10** respectively comprise a recess **103**. When the first cover **11** is disposed in the first sleeve **10**, each of the buckles **111** would be buckled with the corresponding recess **103** to secure the first cover **11** in the first sleeve **10**. In this embodiment, the first cover **11** can also be secured in the first sleeve **10** through a securing member, so that the first cover **11** can be firmly connected with the first sleeve **10**.

[0034] FIG. 10 is a cross-sectional view of an electrical connector of the second embodiment of the present disclosure. FIG. 11 is an enlarged view of area B of FIG. 10. As shown in the figures, the electrical connector **1** of this embodiment is different from that of the first embodiment in the structural configuration of the sealing member **12**. In this embodiment, the sealing member **12** further comprises a positioning sheet **123**. The positioning sheet **123** is disposed on an inner side edge **121a** of the sealing body **121** and extends into an inner space surrounded by the sealing body **121**. When the sealing member **12** is disposed on the first cover **11**, the positioning sheet **123** would cover a part of the first mating surface **11a** of the first cover **11**, and the sealing sheet **122** would protrude from the first mating surface **11a** to position the sealing member **12** on the first cover **11**. In one embodiment, the positioning sheet **123** surrounds and contacts the periphery of the first mating surface **11a**.

[0035] In this embodiment, the sealing member **12** further comprises a securing sheet **124**. The securing sheet **124** is disposed on the inner side **121a** of the sealing body **121** and extends into the inner space surrounded by the sealing body **121**. The securing sheet **124** and the positioning sheet **123** are disposed on the inner side edge **121a** of the sealing body **121** at intervals. When the sealing member **12** is disposed on the first cover **11**, the securing sheet **124** would be embedded into the connector body. That is, the side surface of the first cover **11** further comprises a connecting groove **104** in which the securing sheet **124** is disposed to secure the sealing member **12** on the first cover **11**. The sealing member **12** is positioned and secured on the first cover **11** through the positioning sheet **123** and the securing sheet **124** to avoid displacement during use. It is possible to dispose one of the

positioning piece **123** and the securing piece **124** to position and secure the sealing member **12** on the first cover **11**, which would not be repeated herein.

[0036] In this embodiment, the sealing member **12** further comprises a sealing bump **125**. The sealing bump **125** is disposed on an outer side **121b** of the sealing body **121** and surrounds the sealing body **121**. When the sealing member **12** is disposed on the first cover **11**, the sealing bump **125** would be in contact with the inner surface of the first sleeve **10**. The contacting area of the sealing body **121** and the inner surface of the first sleeve **10** can be reduced through the sealing bump **125** to lower the friction between the sealing body **121** and the inner surface of the first sleeve **10**. In this way, the first sleeve **10** can be sleeved on the first cover **11** and the sealing member **12**, and the sealing member **12** can also seal the gap between the sealing body **121** and the inner surface of the first sleeve **10**, allowing the electrical connector **1** to be well water-proofed. In this embodiment, the number of sealing bumps **125** is one. The number of sealing bumps **125** can be multiple. The plurality of sealing bumps **125** is disposed on an outer side edge **121b** of the sealing body **121** at intervals.

[0037] In summary, embodiments of the present disclosure provide an electrical connector and a connector assembly. The sealing sheet is in contact with the second connecting end surface of the second sleeve of the mating connector and the side surface of the second cover to perform waterproofing of the electrical connector, which reduces friction between the mating connector and the sealing sheet of the sealing member during plugging and unplugging to avoid wear and elastic fatigue of the sealing member. Thus, the waterproof performance of the sealing member could be maintained in excellent condition when it is used for a longer period of time, and the service life of the sealing member can be greatly increased.

[0038] It is to be understood that the term “comprises”, “comprising”, or any other variants thereof, is intended to encompass a non-exclusive inclusion, such that a process, method, article, or device of a series of elements not only comprise those elements but further comprises other elements that are not explicitly listed, or elements that are inherent to such a process, method, article, or device. An element defined by the phrase “comprising a . . .” does not exclude the presence of the same element in the process, method, article, or device that comprises the element.

[0039] Although the present disclosure has been explained in relation to its preferred embodiment, it does not intend to limit the present disclosure. It will be apparent to those skilled in the art having regard to this present disclosure that other modifications of the exemplary embodiments beyond those embodiments specifically described here may be made without departing from the spirit of the disclosure. Accordingly, such modifications are considered within the scope of the disclosure as limited solely by the appended claims.

1. An electrical connector, comprising:
 - a first sleeve comprising a first mating opening and a first connecting end surface, the first connecting end surface being disposed at the periphery of the first mating opening;
 - a first cover disposed in the first sleeve, the first cover comprising a first mating surface exposed from the first mating opening; and
 - a sealing member disposed on a side surface of the first cover, surrounding the first cover, the sealing member

being disposed between the first sleeve and the first cover, the sealing member comprising a sealing sheet extending from the first mating surface in a direction close to the first connecting end surface of the first sleeve.

2. The electrical connector according to claim **1**, wherein the sealing member comprises a sealing body; the sealing sheet comprises a first side and a second side; the first side of the sealing sheet is connected with the sealing body; the sealing sheet is disposed at one side of the sealing body; a gap distance exists between a side edge of the second side of the sealing sheet and the sealing body; the sealing body is disposed on the side surface of the first cover and surrounds the first cover; the second side extends from the first side in a direction away from the sealing body; the extending length of the second side relative to the first side is greater than the gap distance.

3. The electrical connector according to claim **2**, wherein the cross-sectional surface of the sealing sheet along a direction orthogonal to the first mating surface is an inclined surface, a curved surface, or a bent surface.

4. The electrical connector according to claim **2**, wherein an outer side edge of the sealing body is in contact with an inner surface of the first sleeve.

5. The electrical connector according to claim **2**, wherein the sealing member further comprises a positioning sheet disposed on an inner side edge of the sealing body; the positioning sheet extends toward an inner space surrounded by the sealing body; the positioning sheet covers a part of the first mating surface of the first cover.

6. The electrical connector according to claim **5**, wherein the sealing member further comprises a securing sheet disposed on the inner side edge of the sealing body; the securing sheet extends toward the inner space surrounded by the sealing body; the side surface of the first cover comprises a connecting groove in which the securing sheet is disposed.

7. The electrical connector according to claim **2**, wherein the sealing member further comprises a securing sheet disposed on an inner side edge of the sealing body; the securing sheet extends toward an inner space surrounded by the sealing body; the side surface of the first cover comprises a connecting groove in which the securing sheet is disposed.

8. The electrical connector according to claim **2**, wherein the sealing member further comprises a sealing bump disposed on an outer side edge of the sealing body; the sealing bump is in contact with an inner surface of the first sleeve.

9. The electrical connector according to claim **1**, wherein two opposite sides of the first cover are respectively provided with a buckle; the buckle is disposed at one side of the first cover opposite to the first mating surface and extends in a direction away from the first mating surface; two opposite surfaces of the first sleeve are respectively provided with a recess with which the buckle is correspondingly buckled.

10. A connector assembly, comprising:
 - an electrical connector according to claim **1**; and
 - a mating connector comprising a second sleeve and a second cover, the second cover being disposed in the second sleeve, the second sleeve comprising a second connecting end surface, the second cover protruding from the second connecting end surface, when the mating connector being mated with the electrical connector, one side of the sealing sheet close to the first connecting end surface being in contact with the second

connecting end surface of the second sleeve and a side surface of the second cover.

11. The connector assembly according to claim **10**, wherein the two opposite inner surfaces of the first sleeve are respectively provided with a positioning groove disposed between the first connecting end surface and the first mating surface; two opposite outer surfaces of the second sleeve are respectively provided with a positioning bump disposed in the corresponding positioning groove.

12. The connector assembly according to claim **10**, wherein the sealing member comprises a sealing body; the sealing sheet comprises a first side and a second side; the first side of the sealing sheet is connected with the sealing body; the sealing sheet is disposed at one side of the sealing body; a gap distance exists between a side edge of the second side of the sealing sheet and the sealing body; the sealing body is disposed on the side surface of the first cover and surrounds the first cover; the second side extends from the first side in a direction away from the sealing body; the extending length of the second side relative to the first side is greater than the gap distance.

13. The connector assembly according to claim **12**, wherein the cross-sectional surface of the sealing sheet along a direction orthogonal to the first mating surface is an inclined surface, a curved surface, or a bent surface.

14. The connector assembly according to claim **12**, wherein an outer side edge of the sealing body is in contact with an inner surface of the first sleeve.

15. The connector assembly according to claim **12**, wherein the sealing member further comprises a positioning

sheet disposed on an inner side edge of the sealing body; the positioning sheet extends toward an inner space surrounded by the sealing body; the positioning sheet covers a part of the first mating surface of the first cover.

16. The connector assembly according to claim **15**, wherein the sealing member further comprises a securing sheet disposed on the inner side edge of the sealing body; the securing sheet extends toward the inner space surrounded by the sealing body; the side surface of the first cover comprises a connecting groove in which the securing sheet is disposed.

17. The connector assembly according to claim **12**, wherein the sealing member further comprises a securing sheet disposed on an inner side edge of the sealing body; the securing sheet extends toward an inner space surrounded by the sealing body; the side surface of the first cover comprises a connecting groove in which the securing sheet is disposed.

18. The connector assembly according to claim **12**, wherein the sealing member further comprises a sealing bump disposed on an outer side edge of the sealing body; the sealing bump is in contact with an inner surface of the first sleeve.

19. The connector assembly according to claim **10**, wherein two opposite sides of the first cover are respectively provided with a buckle; the buckle is disposed at one side of the first cover opposite to the first mating surface and extends in a direction away from the first mating surface; two opposite surfaces of the first sleeve are respectively provided with a recess with which the buckle is correspondingly buckled.

* * * * *