



US 20120138761A1

(19) **United States**

(12) **Patent Application Publication**
Messinger

(10) **Pub. No.: US 2012/0138761 A1**

(43) **Pub. Date: Jun. 7, 2012**

(54) **CORBELLED-SUPPORT APPARATUS**

(52) **U.S. Cl. 248/226.11; 248/310; 248/250**

(76) **Inventor: Glen Robert Messinger, Phoenix, AZ (US)**

(57) **ABSTRACT**

(21) **Appl. No.: 12/962,123**

A corbelled-support apparatus includes a support which has a horizontal surface and a vertical surface, a corbel which has opposed top and bottom ends, and a platform positioned concurrently on and supported concurrently by the horizontal surface of the support and the top end of the corbel. The corbel is secured to the vertical surface of the support. The platform is for receiving and supporting display items with respect to the horizontal surface of the support and the corbel.

(22) **Filed: Dec. 7, 2010**

Publication Classification

(51) **Int. Cl. A47G 29/00 (2006.01)**

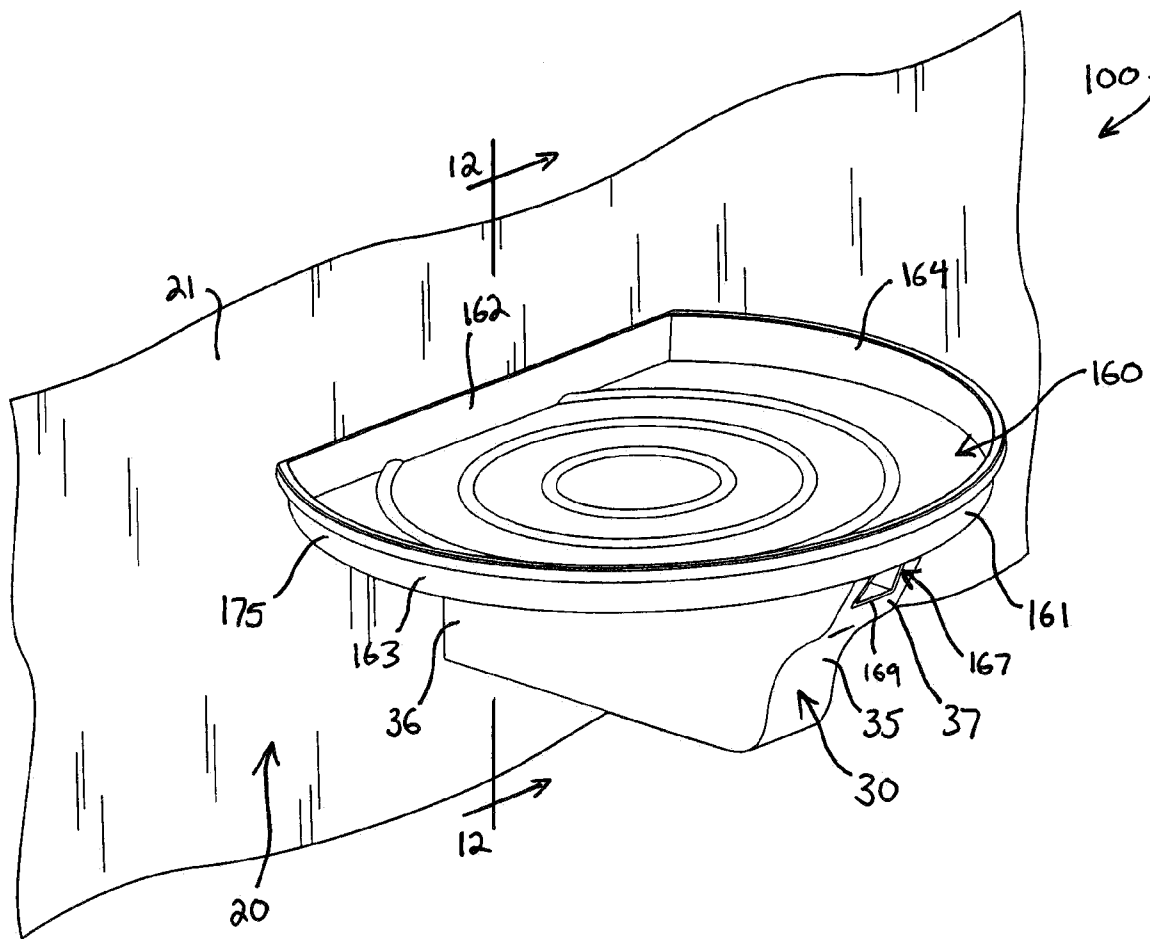

FIG. 1

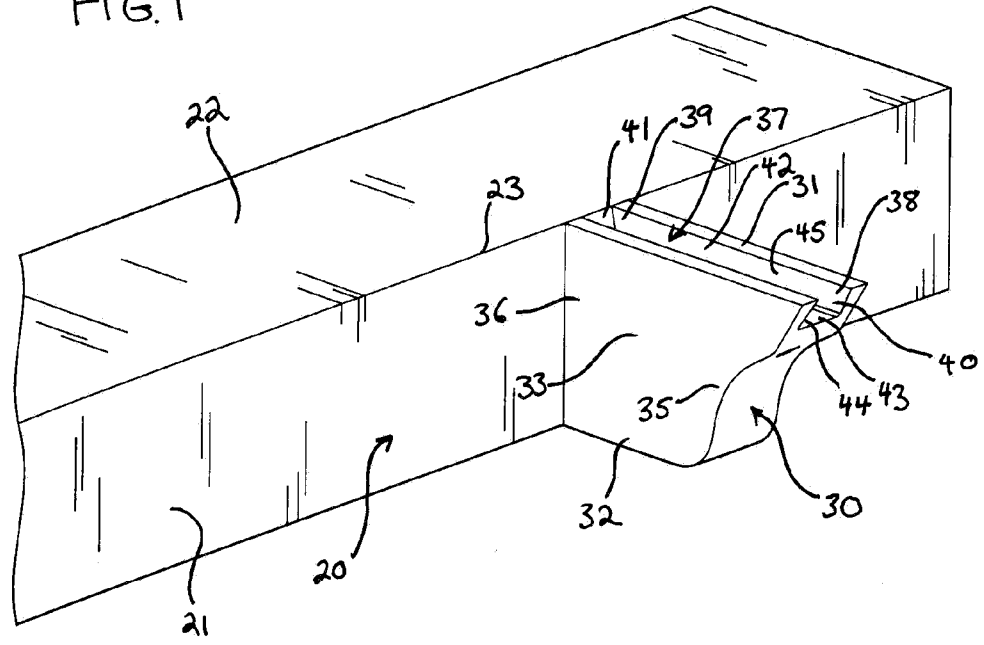

FIG. 2

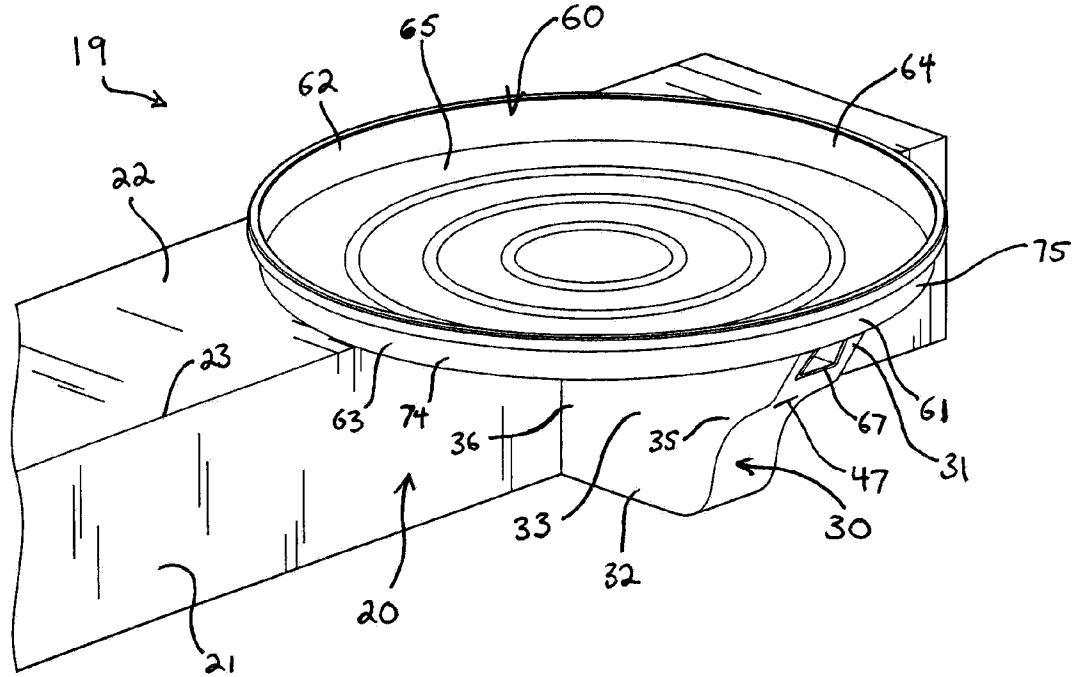

FIG. 3

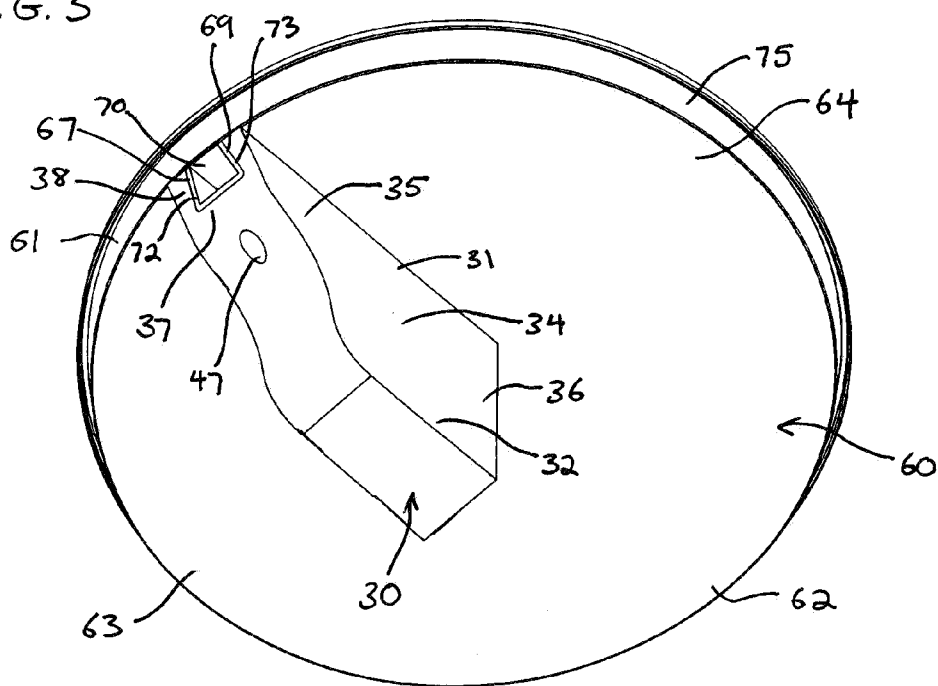

FIG. 4

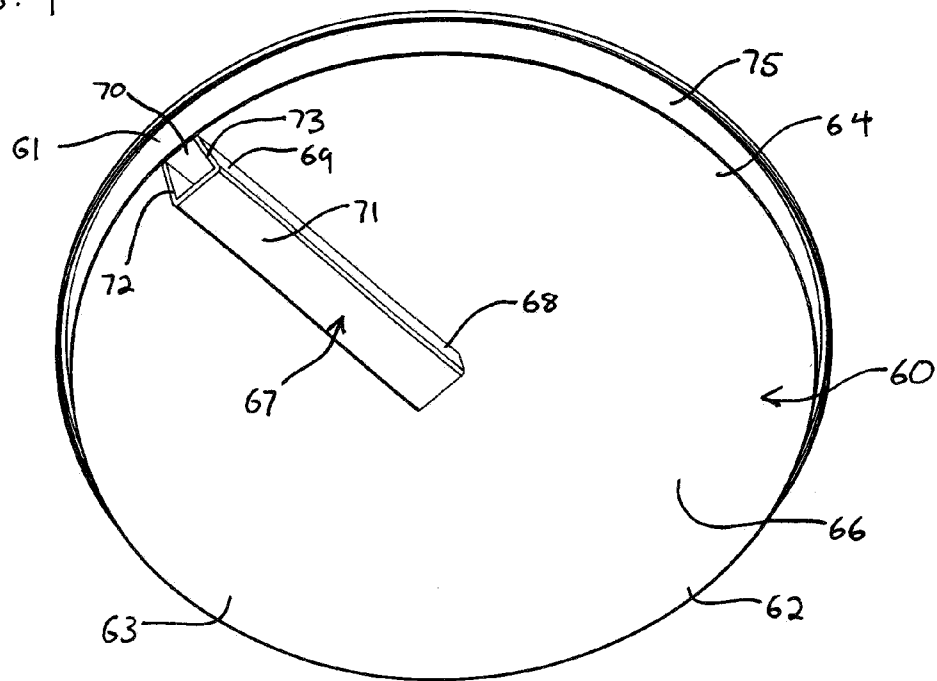

FIG. 5

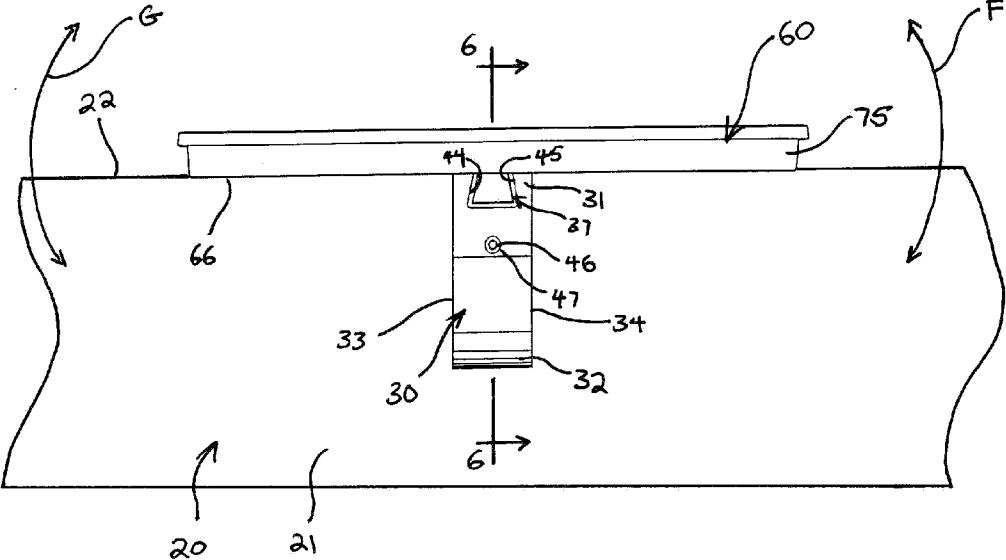

FIG. 6

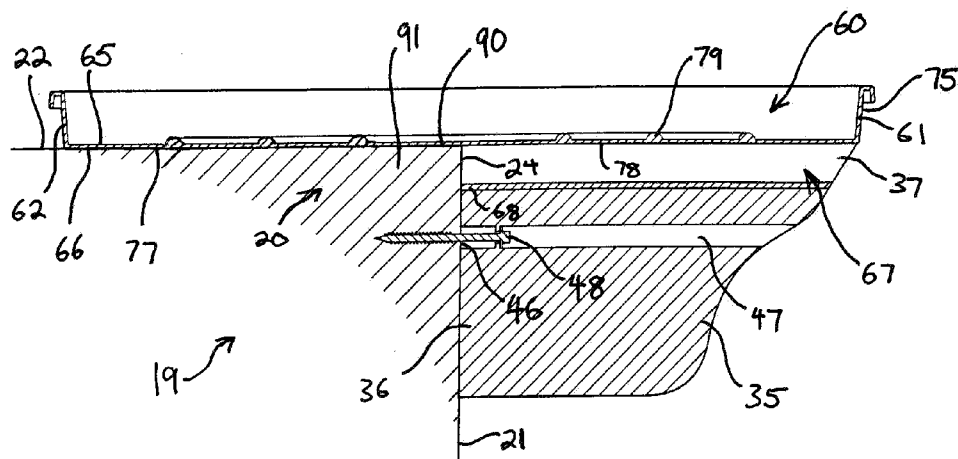

FIG. 7

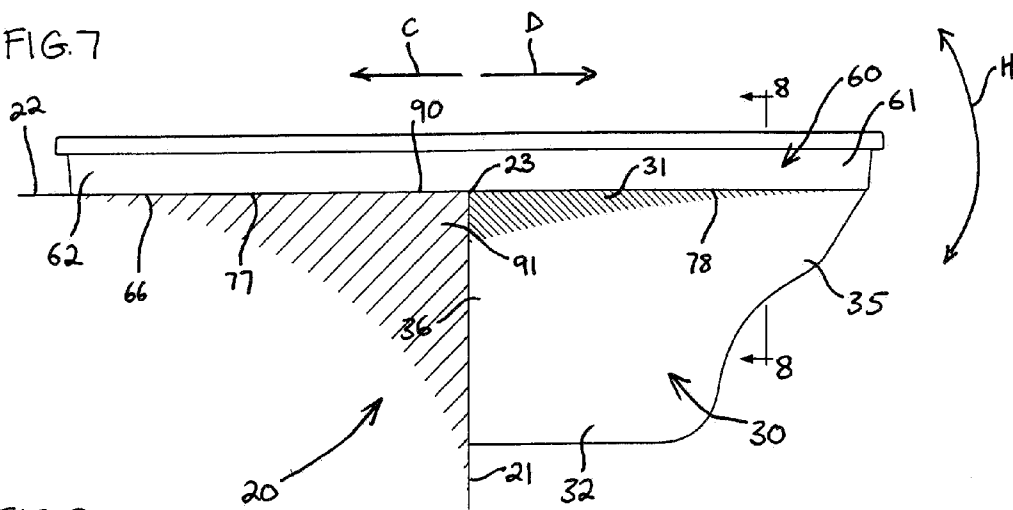

FIG. 8

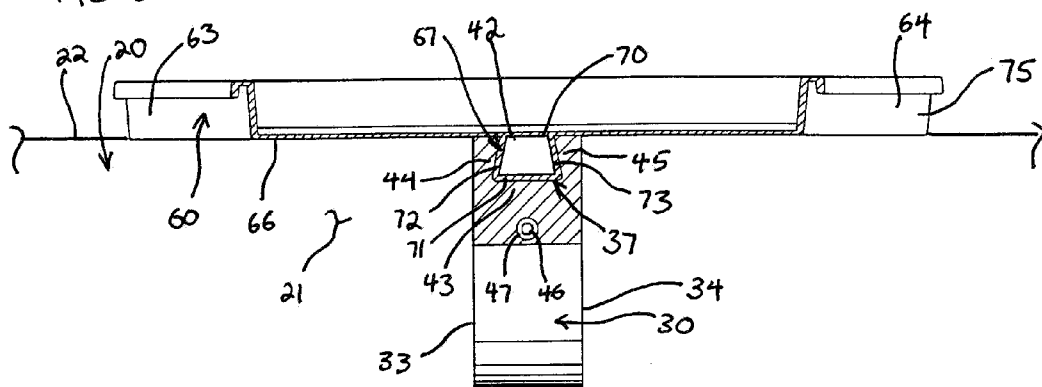

FIG. 9A

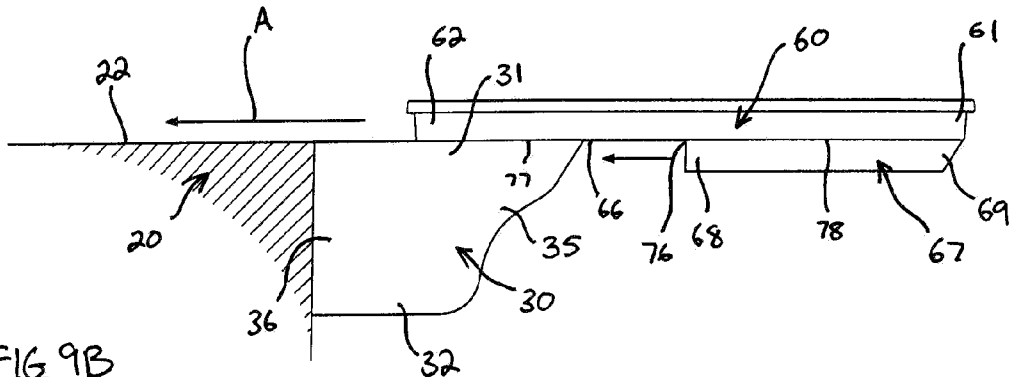

FIG. 9B

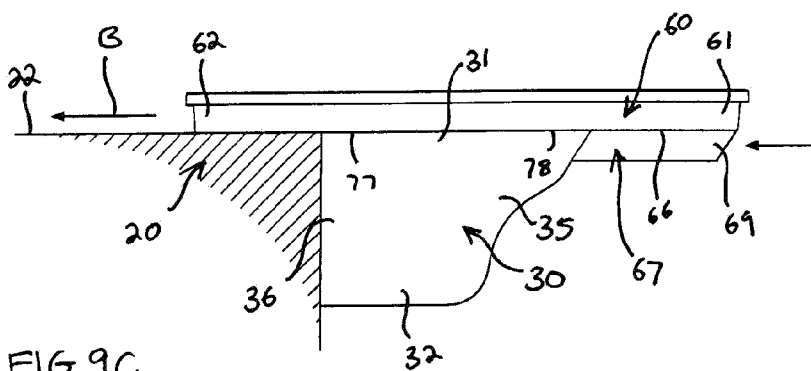

FIG. 9C

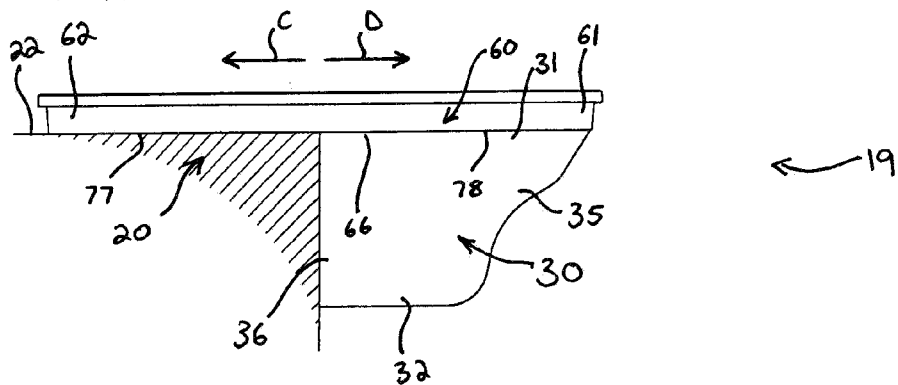

FIG. 10A

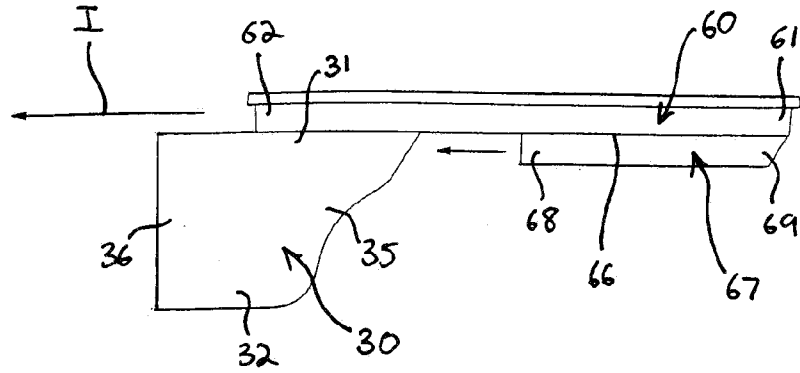

FIG. 10B

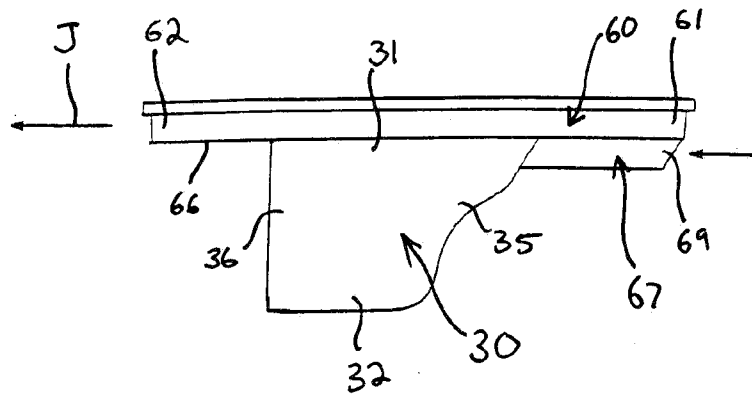

FIG. 10C

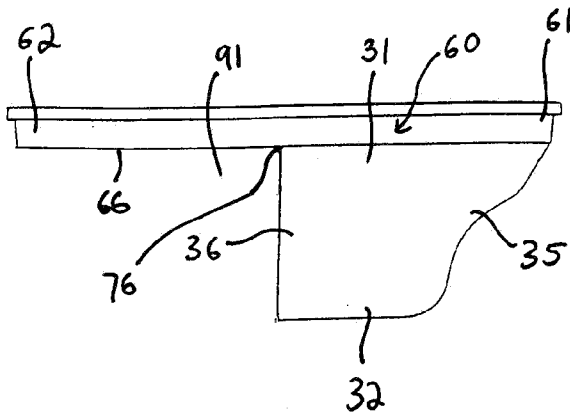

FIG. 12

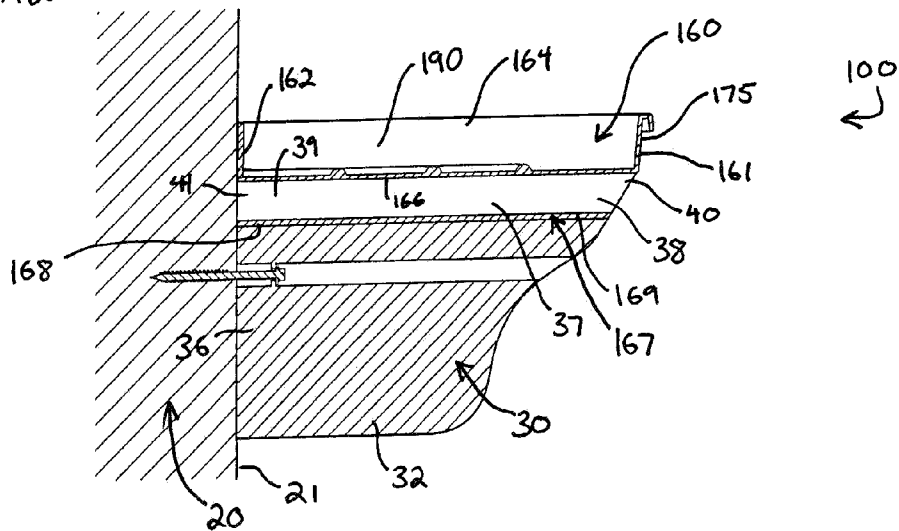

FIG. 11

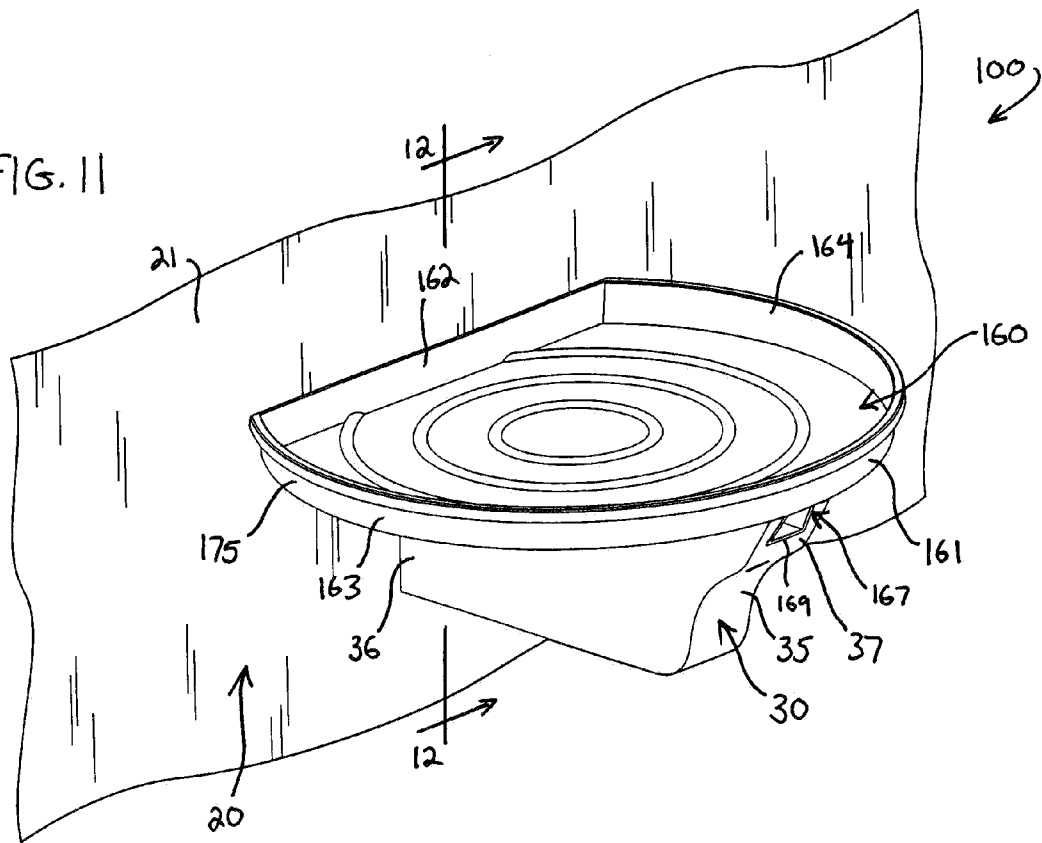

FIG. 13

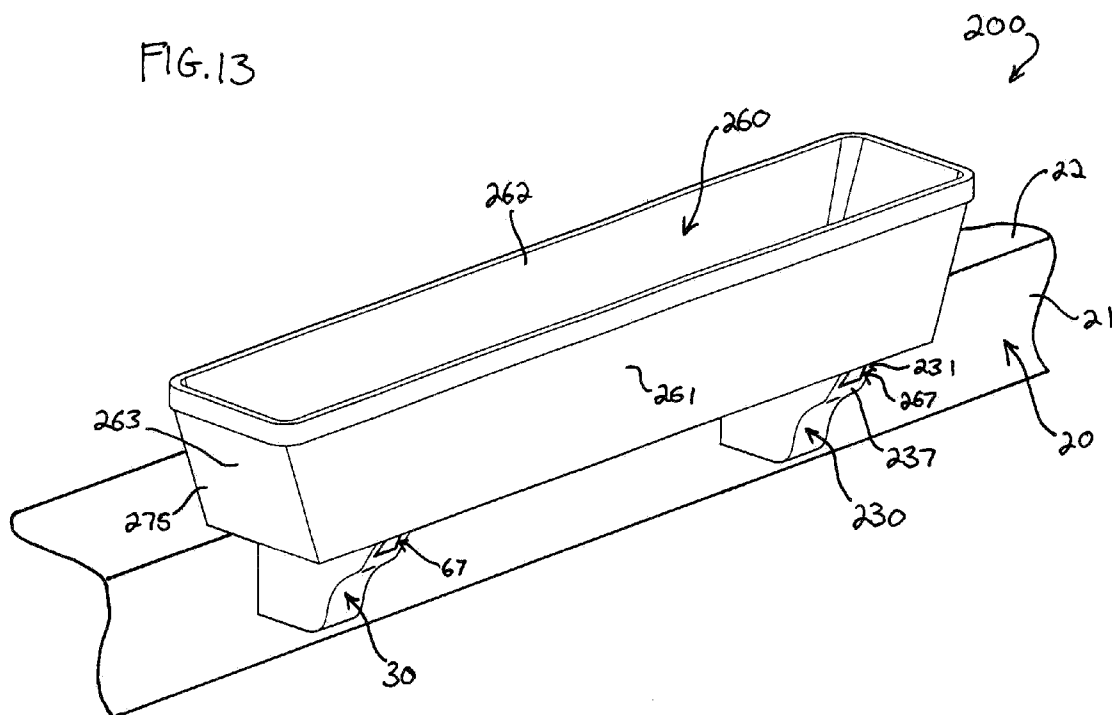
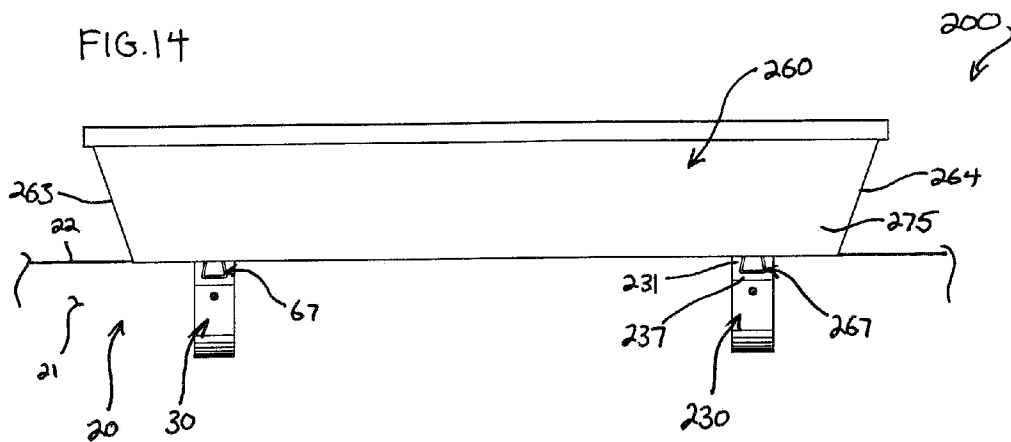

FIG. 14



CORBELLED-SUPPORT APPARATUS

FIELD OF THE INVENTION

[0001] The present invention relates generally to display devices, and more particularly to display devices supporting items for display at walls, sills, and support structures.

BACKGROUND OF THE INVENTION

[0002] People often desire to place large objects on windowsills, shelves, platforms, and against or on top of walls. However, the limited area available to place such an object may render placement impractical or even dangerous. Because some objects, such as growing plants, may be large and heavy, supporting and stabilizing them on areas that are smaller than the objects themselves may be impossible. A safer, more secure way to support and display an object is needed other than merely placing the object on the sill or shelf.

SUMMARY OF THE INVENTION

[0003] According to the principle of the invention, a corbelled-support apparatus includes a support having a horizontal surface and a vertical surface, a corbel having opposed top and bottom ends, the corbel secured to the vertical surface of the support, and a platform positioned concurrently on and supported concurrently by the horizontal surface of the support and the top end of the corbel. The platform receives and supports display items with respect to the horizontal surface of the support and the corbel. An engagement assembly couples the platform to the corbel and includes an engagement element carried by the platform and a complementary engagement element carried by the corbel. The engagement element is one of a tongue and a groove, and the complementary engagement element is the other of the tongue and the groove. In an embodiment, the platform includes opposed front and rear ends, opposed sides, opposed top and bottom surfaces, the engagement element is a tongue, the complementary engagement element is a groove, the tongue includes opposed leading and trailing ends, and the tongue extends along the bottom surface of the platform from the leading end located at an intermediate position with respect to the bottom surface to the trailing end positioned near the front end of the platform. An area of the vertical surface of the support is exposed at the groove inboard with respect to the top end of the corbel, and the leading end of the tongue extending along the bottom surface of the platform is encountered by and received in juxtaposition with respect to the area of the vertical surface of the support exposed at the groove. The corbel is rigidly secured to the vertical surface of the support at a point of attachment, and the point of attachment is located at an intermediate position with respect to the top and bottom ends of the corbel. The point of attachment cooperates with the platform positioned concurrently on and supported concurrently by the horizontal surface of the support and the top end of the corbel to secure the corbel and the platform to the support. The leading end of the tongue cooperates with the bottom surface of the platform to form an inward platform corner, the horizontal and vertical surfaces of the support meet and merge at an outward support corner, and the inward platform corner receives the outward support corner, the leading end of the tongue received in juxtaposition with the vertical surface of the support at the area of the vertical surface of the support exposed at the groove. The tongue is concealed by

the corbel between the leading and trailing ends of the tongue, and the tongue extends along the bottom surface of the platform at an intermediate position with respect to the opposed sides of the platform. In an embodiment, a second corbel includes top and bottom ends, and the second corbel is secured to the vertical surface of the support. A second engagement assembly couples the platform to the second corbel and includes a tongue carried by the platform and a groove carried by the second corbel. The tongue extends along the bottom surface of the platform at a position proximate to one of the sides, and the tongue extends along the bottom surface of the platform at a position distal to the one of the sides.

[0004] According to the principle of the invention, a corbelled-support apparatus includes a platform, a corbel, an engagement assembly coupling the platform to the corbel which includes an engagement element carried by the platform and a complementary engagement element carried by the corbel, and a receiving area formed by and between the platform and the corbel to receive a support having a horizontal surface and a vertical surface. The support is received in the receiving area, the corbel is secured to the vertical surface of the support, and the platform is supported by the horizontal surface of the support. The platform receives items for display with respect to the support. The platform includes opposed top and bottom surfaces, the engagement element is carried by the bottom surface of the platform, the corbel includes opposed top and bottom ends, and the complementary engagement element is carried by the top end of the corbel. The engagement element is one of a tongue and a groove, and the complementary engagement element is the other of the tongue and the groove. In an embodiment, the platform includes opposed front and rear ends and opposed sides, the engagement element is a tongue, the complementary engagement element is a groove, the tongue includes opposed leading and trailing ends, and the tongue extends along the bottom surface of the platform from the leading end located at an intermediate position with respect to the bottom surface to the trailing end positioned near the front end of the platform. The tongue is concealed by the corbel between the leading and trailing ends of the tongue, and the tongue extends along the bottom surface of the platform at an intermediate position with respect to the opposed sides. A first portion of the platform is positioned between the opposed sides of the platform and extends from the front end of the platform to an intermediate location of the platform between the opposed front and rear ends of the platform. A second portion of the platform is positioned between the opposed sides of the platform and extends from the rear end of the platform to an intermediate location of the platform between the opposed front and rear ends of the platform. The first portion of the platform is supported by the corbel and the second portion of the platform is supported by the horizontal surface of the support. The corbel is rigidly secured to the vertical surface of the support at a point of attachment, the point of attachment is located at an intermediate position with respect to the top and bottom ends of the corbel and the point of attachment cooperates with the second portion of the platform supported by the horizontal surface of the support to secure the corbel and platform to the support. The leading end of the tongue cooperates with the bottom surface of the platform to form an inward platform corner, the horizontal and vertical surfaces of the support meet and merge at an outward support corner, and the inward

platform corner receives the outward support corner, the leading end of the tongue received in juxtaposition with the vertical surface of the support.

[0005] According to the principle of the invention, a corbelled-support apparatus includes a support having a vertical surface, a corbel having opposed top and bottom ends, the corbel secured to the vertical surface of the support, and a receiving area formed by and between the vertical surface of the support and the top end of the corbel to receive a platform having a bottom surface. The platform is received in the receiving area. An engagement assembly formed between and coupling the platform to the corbel includes an engagement element carried by the bottom surface of the platform and a complementary engagement element carried by the corbel. The engagement element slidably and releasably couples the complementary engagement element releasably securing the platform to the top end of the corbel. In an embodiment, the engagement element is a tongue, the complementary engagement element is a groove, the tongue includes opposed leading and trailing ends, and the tongue extends along the bottom surface of the platform between the opposed front and rear ends of the platform and extends along the bottom surface at an intermediate position with respect to the opposed sides of the platform. The tongue is concealed by the corbel between the leading and trailing ends of the tongue. The corbel is rigidly secured to the vertical surface of the support at a point of attachment, the point of attachment is located at an intermediate position with respect to the top and bottom ends of the corbel, and the point of attachment cooperates with the platform positioned concurrently on and against the vertical surface of the support and the top end of the corbel to secure the corbel and the platform to the support. The platform receives and supports display items with respect to the corbel and the vertical surface of the support.

BRIEF DESCRIPTION OF THE DRAWINGS

[0006] Referring to the drawings:

[0007] FIG. 1 is a front isometric view of a corbel applied to a support in accordance with the principle of the invention;

[0008] FIG. 2 is a front isometric view of a corbelled-support apparatus constructed and arranged in accordance with the principle of the invention, including a corbel, a support, and a platform;

[0009] FIG. 3 is a bottom isometric view of a corbel applied to a platform in accordance with the principle of the invention;

[0010] FIG. 4 is a bottom isometric view of the platform of FIG. 3 with the corbel removed;

[0011] FIG. 5 is a front elevation view of the corbel and platform of FIG. 3 applied to a support;

[0012] FIG. 6 is a section view taken along line 6-6 of FIG. 5;

[0013] FIG. 7 is a side elevation view of the corbelled-support apparatus of FIG. 2;

[0014] FIG. 8 is a section view taken along line 8-8 of FIG. 7;

[0015] FIGS. 9A-9C are side elevation views of a platform being moved from a removed position to an applied position with respect to a corbel at a support, forming the corbelled-support apparatus of FIG. 2;

[0016] FIGS. 10A-10C are side elevation views of a platform being moved from a disengaged position to an engaged position with respect to a corbel, forming the corbel applied to the platform as shown in FIG. 3;

[0017] FIG. 11 is a front isometric view of a corbelled-support apparatus constructed and arranged in accordance with the principle of the invention;

[0018] FIG. 12 is a section view of the corbelled-support apparatus taken along line 12-12 of FIG. 11;

[0019] FIG. 13 is a front isometric view of a corbelled-support apparatus constructed and arranged in accordance with the principle of the invention; and

[0020] FIG. 14 is a front elevation view of the corbelled-support apparatus shown in FIG. 12.

DETAILED DESCRIPTION

[0021] Turning now to the drawings, in which like reference characters indicate corresponding elements throughout the several views, attention is first directed to FIG. 1 illustrating a support 20 having a vertical surface 21 and a horizontal surface 22. A corbel 30 is secured to vertical surface 21 of support 20. FIG. 2 illustrates support 20 and corbel 30. In FIG. 2, a platform 60 is positioned concurrently on and supported concurrently by horizontal surface 22 of support 20 and corbel 30 to receive and support display items with respect to horizontal surface 22 of support 20 and corbel 30.

[0022] Support 20 is a rigid, solid structure and is exemplary of a structure formed at a windowsill, countertop, top of a pony wall, or other similar structure. Support 20 provides a rigid, solid structure for mounting corbel 30 and platform 60 and is constructed out of a rigid, resilient material such as wood, plastic, metal, drywall, or like material. Vertical surface 21 and horizontal surface 22 of support 20 are planar and transverse with respect to each other. Vertical surface 21 and horizontal surface 22 meet and merge at and along an outward support corner 23.

[0023] Referring now to FIG. 1, corbel 30 is constructed of a rigid, resilient, lightweight material such as plastic, wood, metal, or the like. Corbel 30 includes opposed top and bottom ends 31 and 32, opposed sides 33 and 34 extending between top and bottom ends 31 and 32, and opposed front and rear ends 35 and 36 extending from top end 31 to bottom end 32 between sides 33 and 34. Top and bottom ends 31 and 32 are longitudinal with respect to each other. Sides 33 and 34 are longitudinal with respect to each other and longitudinal with respect to top and bottom ends 31 and 32. Front end 35 is arcuate between top and bottom ends 31 and 32 and cants toward rear end 36 between top and bottom ends 31 and 32. Rear end 36 is longitudinal with respect to front end 35, transverse with respect to top and bottom ends 31 and 32, and transverse with respect to sides 33 and 34.

[0024] Corbel 30 is formed with a groove 37. Groove 37 extends into corbel 30 along top end 31 from front end 35 to rear end 36 at a generally intermediate location with respect to opposed sides 33 and 34. Groove 37 includes opposed front and rear groove ends 38 and 39 extending between front and rear ends 35 and 36 of corbel 30. Front groove end 38 forms an opening 40 in front end 35 of corbel 30, and rear groove end 39 forms an opposed opening 41 in rear end 36 of corbel 30. Additionally, groove 37 includes a groove opening 42, an opposed groove base 43, and opposed groove walls 44 and 45 extending between groove opening and base 42 and 43. Groove opening 42 extends from front groove end 38 to rear groove end 39 along top end 31. Groove base 43 is longitudinal with respect to groove opening 42 and extends from front groove end 38 to rear groove end 39 inboard with respect to top end 31. Groove 37 varies in width, expanding in width from groove opening 42 to groove base 43. Wall 44 cants

toward side 33 from groove opening 42 to groove base 43, and opposed wall 45 cants toward side 34 from groove opening 42 to groove base 43. Groove 37 is narrowest along top end 31. [0025] With continued reference to FIG. 1, corbel 30 is secured to vertical surface 21 of support 20 proximate to outward support corner 23. Rear end 36 of corbel 30 is received in juxtaposition against vertical surface 21 of support 20. Sides 33 and 34 are transverse with respect to vertical surface 21 of support 20. Top and bottom ends 31 and 32 of corbel 30 are longitudinal with respect to horizontal surface 22 of support 20, and top end 31 is level with horizontal surface 22. Corbel projects outward from vertical surface 21 of support 20 from rear end 36 to front end 35.

[0026] Corbel 30 partially conceals outward support corner 23 at top and rear ends 31 and 36 of corbel 30. Groove 37 extends from front end 35 of corbel 30 to rear end 36 of corbel 30 and to vertical surface 21 of support 20, revealing an area 24 of vertical surface 21 exposed at opening 41 of groove 37 at rear groove end 39. Area 24 extends across vertical surface 21 between groove walls 44 and 45 from groove base 43 to groove opening 42 and outward support corner 23. Similarly, outward support corner 23 is exposed at opening 41 of groove 37 at rear groove end 39.

[0027] Turning now to FIG. 6, corbel 30 is rigidly secured to vertical surface 21 of support 20 at an attachment point 46. Attachment point 46 is located on rear end 36 at an intermediate position with respect to top and bottom ends 31 and 32 of corbel 30. A pocket 47 extends through corbel 30 from front end 35 to rear end 36 at attachment point 46. Attachment point 46 is part of pocket 47 located at rear end 36. Pocket 47 provides access to attachment point 46. A screw 48 or other fastener at attachment point 47 rigidly secures corbel 30 to vertical surface 21 of support 20.

[0028] Referring now to FIG. 2, platform 60 is positioned concurrently on and supported concurrently by horizontal surface 22 of support 20 and top end 31 of corbel 30. Platform 60 is constructed of a rigid, resilient, lightweight material such as plastic, wood, metal, or the like. Platform 60 resists bending or flexing and is formed with a series of concentric annular ridges 79 integral to platform 60, further decreasing the flexibility of platform 60.

[0029] Platform includes opposed front and rear ends 61 and 62, opposed sides 63 and 64, and opposed top and bottom surfaces 65 and 66. Platform 60 is substantially planar and uniform in thickness between opposed top and bottom surfaces 65 and 66. In the embodiment shown in FIG. 2, FIG. 3, and FIG. 4, platform 60 is circular. In other embodiments, consistent with the teachings set forth herein, platform 60 may be triangular, rectangular, square, oval, or other shapes.

[0030] Top and bottom surfaces 65 and 66 meet and merge at a perimeter edge 74. In the embodiment shown in FIG. 2, perimeter edge 74 is turned up away from top surface 65, forming a sidewall 75. Sidewall 75 is formed at perimeter edge 74 and bounds platform 60, preventing display items supported by and received on platform from sliding or falling off platform 60. Sidewall 75 further prevents overflow water applied to plants supported on platform 60 from spilling off of platform 60. Sidewall 75 provides structural rigidity across platform 60 in addition to that inherent in the material of platform 60.

[0031] FIG. 4 illustrates a tongue 67 formed on bottom surface 66 of platform 60 extending away from bottom surface 66. Tongue 67 includes opposed leading and trailing ends 68 and 69 and extends along bottom surface 66 of platform 60

from leading end 68 located at an intermediate position with respect to bottom surface 66 to trailing end 69 positioned near front end 61 of platform 60. Tongue 60 further extends along bottom surface 66 of platform 60 at an intermediate position with respect to opposed sides 63 and 64 of platform 60.

[0032] Tongue 67 includes opposed tongue top 70 and tongue base 71, and opposed tongue walls 72 and 73 extending between tongue top 70 and tongue base 71 from leading end 68 to trailing end 69. Tongue top 70 extends from leading end 68 to trailing end 69 of tongue 60 and front end 61 of platform 60. Tongue base 71 is longitudinal with respect to tongue top 70 and bottom surface 66, extending from leading end 68 to trailing end 69 of tongue 60 and front end 61 of platform 60. Tongue 67 varies in width, expanding in width from tongue top 70 to tongue base 71. Wall 72 cants toward side 63 of platform 60 from tongue top 70 to tongue base 71. Wall 73 cants toward side 64 of platform 60 from tongue top 70 to tongue base 71. Tongue 67 is narrowest along tongue top 70 at bottom surface 66. Trailing end 69 of tongue 67 cants away from front end 61 toward rear end 62 of platform 60 from tongue top 70 to tongue base 71. Leading end 68 is transverse with respect to bottom surface 66.

[0033] With momentary reference now to FIG. 9A, tongue 60 projects downward below bottom surface 66 of platform 60. Leading end 68 of tongue 67 cooperates with bottom surface 66 of platform 60 to form an inward platform corner 76.

[0034] As shown in FIG. 8, platform 60 is applied to corbel 30 and a portion of bottom surface 66 is received by and rests upon top end 31 of corbel 30. Platform 60 is coupled to corbel 30, tongue 67 and groove 37 forming an engagement assembly coupling platform 60 to corbel 30. Tongue 67 is an engagement element carried by platform 60 and groove is a complementary engagement element carried by corbel 30.

[0035] Platform 60 and corbel 30 are applied and mounted to each other and to support 20 in a variety of manners. In one manner, corbel 30 is first mounted to support 20, and platform 60 is then applied to corbel 30. In another manner, platform 60 is applied to corbel 30, and corbel 30 and platform 60 are then applied, contemporaneously, to support 20. The former manner will first be described; the latter manner will be described thereafter.

[0036] In the first manner of applying platform 60 and corbel 30 to support 20, corbel 30 is registered with vertical surface 21 of support 20 ready to be applied. Corbel 30 is advanced toward support 20 and applied against vertical surface 21, shown in FIG. 1. Corbel 30 is then secured to vertical surface 21 of support 20 at attachment point 46 by a screw 48 or other fastener. Screw 48 is tightened against attachment point 46, clamping corbel 30 to vertical surface 21 and creating a friction fit between rear end 36 and vertical surface 21 of support 20 that resists movement or rotation of corbel 30 about attachment point 46. Corbel 30 can still be rotated by taking corbel 30 up by hand and applying force against corbel 30 in a clockwise or counterclockwise rotational direction with respect to attachment point 46 to level top end 31 with respect to horizontal surface 22 of support 20. Top end 31 and horizontal surface 22 of support 20 cooperate to form an upper receiving area 90 which extends from front end 35 of corbel 30 along top end 31 to horizontal surface 22 inboard with respect to outward support corner 23.

[0037] Upper receiving area 90 is adapted to receive platform 60. Platform 60 is moveable between a first, removed position with respect to corbel 30, and a second, applied

position with respect to corbel 30. In the first position, platform 60 is removed, unattached, and apart from corbel 30. In the second position, platform 60 is applied to and received by upper receiving area 90, support 20, and corbel 30, groove 37 receiving tongue 67 in sliding engagement.

[0038] FIG. 9A, FIG. 9B, and FIG. 9C illustrate steps of applying platform 60 to corbel 30 mounted to support 20. FIG. 9A shows platform 60 in its first, removed position with respect to corbel 30. In this removed position, platform 60 is registered with corbel 30 for ready application to corbel 30. Rear end 62 of platform 60 is proximate to front end 35 of corbel 30, and front end 61 of platform is away from front end 35 of corbel 30. Rear end 62 of platform 60 is proximate to outward support corner 23 of support 20, and front end 61 of platform is away from outward support corner 23 of support 20. Bottom surface 66 of platform 60 is longitudinal to and level with top end 31 and horizontal surface 22. Bottom surface 66 is flat with respect to horizontal surface 22. A portion of bottom surface 66 rests on top end 31. Tongue 67 is registered with groove 37 in a readied position to slide into groove 37. Leading end 68 of tongue 67 is proximate to front end 35 of corbel 30, and trailing end 69 is away from front end 35. Further, trailing end 69 is opposed from outward support corner 23 of support 20 with respect to front end 35 and leading end 68. Platform 60 is moved from its first position to its second position by advancing platform 60 along arrowed line A.

[0039] FIG. 9B illustrates platform 60 partially applied to corbel 30 between the first and second positions. Leading end 68 of tongue 67 is within groove 37, hidden and obscured from view, while trailing end 69 is outside groove 37, exposed and viewable. Bottom surface 66 of platform is received in juxtaposition by and rests against top end 31 of corbel 30 and horizontal surface 22 of support 20. Rear end 62 of platform 60 rests partially on horizontal surface 22. Front end 61 of platform 60 is partially cantilevered off front end 35 of corbel 30. Platform 60 is further moved from its first position to its second position by advancing platform 60 along arrowed line B.

[0040] FIG. 9C illustrates platform 60 in its second position. Platform 60 is applied to corbel 30 and support 20, and is positioned concurrently on and supported concurrently by horizontal surface 22 of support 20 and top end 31 of corbel 30. Bottom surface 66 of platform 60 is received at and in juxtaposition with upper receiving area 90. Rear end 62 is supported by support 20; a rear area 77 of bottom surface 66 rests against and is supported by horizontal surface 22 of support 22. Front end is supported by corbel 30. A front area 78 of bottom surface 66 rests against and is supported by top end 31 of corbel 30, and corbel 30 is secured to vertical surface 21 of support 20. Tongue 67 is now concealed by corbel 60 between leading and trailing ends 68 and 69 of tongue 67 and is hidden from a view across vertical surface normal to sides 33 and 34 of corbel. Trailing end 69 is flush with front end 35 of corbel 30 and visible from a line of sight longitudinal with respect to groove 37. Referring to FIG. 6, which shows platform 60 in its second position, leading end 68 of tongue 67 is encountered by and received in juxtaposition with respect to area 24 of vertical surface 21 of support 20 exposed at groove 37. Inward platform corner 76 formed between bottom surface 66 and leading end 68 of tongue 67 receives outward support corner 23 of support 20, leading end 68 of tongue 67 received in juxtaposition with vertical surface

21 and bottom surface 66 received in juxtaposition with horizontal surface 22 of support 20.

[0041] The foregoing description is exemplary of a first manner of applying and securing platform 60, corbel 30, and support 20 to each other in which corbel 30 is first mounted to support 20 and then platform 60 is applied to corbel 30 and support 20. In a second manner, now described, platform 60 is applied to corbel 30, and corbel 30 and platform 60 are then applied, contemporaneously, to support 20.

[0042] In this manner, platform 60 alternates between a first, disengaged condition and a second, engaged condition with respect to corbel 30. FIG. 4 illustrates the first condition of platform 60, and FIG. 3 illustrates the second condition of platform 60. In the first condition of platform 60, platform 60 is disengaged and unattached from anything. In the second condition of platform 60, corbel 30 is mounted to platform 60, tongue 67 of platform 60 receiving groove 37 formed in corbel 30.

[0043] To place platform 60 in the second condition, corbel 30 is registered with platform 60, groove 37 aligned with tongue 67, as shown in FIG. 10A. Leading end 68 of tongue 67 is proximate to front end 35 of corbel 30, and trailing end 69 is away from front end 35. Platform 60 is moved from its first condition to its condition by advancing platform 60 along a direction indicated by arrowed line I longitudinal with respect to groove 37. Although platform 60 is described here as moved onto corbel 30 from the front end 35 of corbel to the rear end 36, it will be appreciated that, because groove 37 is open at both front and rear groove ends 38 and 39, platform could also be moved onto corbel 30 from the rear end 36 to the front end 35.

[0044] FIG. 10B illustrates platform 60 partially applied to corbel 30 between the first and second conditions. Leading end 68 of tongue 67 is within groove 37, hidden and obscured from view, while trailing end 69 is outside groove 37, exposed and viewable. Top end 31 of corbel 30 is entirely applied against bottom surface 66 of platform 60, though bottom surface 66 of platform 60 is only partially applied to top end 31 of corbel 30. Platform 60 is further moved from its first condition to its second condition by advancing platform 60 along arrowed line J in FIG. 10B.

[0045] FIG. 10C illustrates platform 60 in its second condition. Platform 60 is coupled to corbel 30 along top end 31, tongue 67 engaged with groove 37. Tongue 67 is concealed by corbel 60 between leading and trailing ends 68 and 69 and is hidden from a view normal to sides 33 and 34 of corbel 30. Leading end 68 of tongue 67 is flush and even with rear end 36 of corbel 30, leading end 68 positioned within rear groove end 39 of groove 30. As shown in FIG. 3, trailing end 69 is flush with front end 35 of corbel 30 and front groove end 38 of groove 37, and is visible from a line of sight longitudinal with respect to groove 37.

[0046] In this second condition of platform 60, front area 78 of bottom surface 66 of platform 60 is received at and in juxtaposition with top end 31 of corbel 30. Rear area 77 of bottom surface 66 is free and exposed. A receiving area 91 is formed by and between platform 60 and corbel 30. Receiving area 91 extends between rear end 36 and rear area 77 of bottom surface 66 of platform 60, from between opposed sides 63 and 64 of platform 60. Inward platform corner 76 is located within receiving area 91.

[0047] In the second condition of platform 60, platform 60 and corbel 30 are in a ready condition to be mounted and secured to support 20. Receiving area 91 receives support 20

to apply corbel 30 and platform 60 to support 20. Support 20 is applied to and received in receiving area 91, vertical surface 21 is received in juxtaposition with respect to rear end 36 of corbel 30, horizontal surface 22 is received in juxtaposition with respect to rear area 77 of bottom surface 66 of platform, outward support corner 23 is received in juxtaposition with respect to inward platform corner 76, and leading end 68 of tongue 67 received in juxtaposition with vertical surface 21 of support 20.

[0048] As illustrated in FIG. 6 and FIG. 7, corbel 30 is secured to vertical surface 21 of support 20, and platform 60 is supported by horizontal surface 22 of support 20, platform 60 for receiving items for display with respect to support 20. Attachment point 46 cooperates with rear end 62 of platform 60 to secure corbel 30 and platform 60 to support 20. FIG. 7 shows rear end 62 of platform 60 is supported by support 20, rear area 77 of bottom surface 66 resting against and supported by horizontal surface 22 of support 20. Likewise, front end 61 of platform 60 is supported by corbel 30, front area 78 of bottom surface 66 resting against and supported by top end 31 of corbel 30, corbel 30 secured to vertical surface 21.

[0049] Platform 60, corbel 30, and support 20 are secured through one of the manners described above or through another manner, so that items may be received, supported, and displayed on platform 60. With continuing reference to FIG. 7, platform 60 cannot be moved out of its second position without an application of force. Outward support corner 23 and inward platform corner 76 operate to limit movement of tongue 67 past vertical surface 21, preventing movement of platform 60 in a direction indicated by arrowed line C. Likewise, platform cannot be moved in a direction indicated by arrowed line D without an application of force. Friction between tongue 67 and groove 37 prevents platform from sliding off corbel 30 and support 20. Tongue 67 fits snugly within groove 37, which is shaped to receive tongue 67, as shown in FIG. 8.

[0050] FIG. 8 shows the secure engagement of tongue 67 within groove 37. Tongue base 71 is received in juxtaposition against groove base 43, wall 72 of tongue 67 is received in juxtaposition against wall 44 of groove 37, and wall 73 of tongue 67 is received in juxtaposition against wall 45 of groove 37.

[0051] Although tongue 60 is slideably and releasably received by groove 30 in a longitudinal direction indicated by arrowed line C, tongue 67 and groove 37 form a friction fit which resists sliding and releasing. Contact and friction between tongue base 71 and groove base 43, between wall 72 and wall 44, and between 73 and wall 45 prevents withdrawal of tongue 67 from groove 37 in a direction indicated by arrowed line D in FIG. 7, longitudinal with respect to groove 37 and normal to vertical surface 21. Tongue 67 also cannot be removed from groove 37 in a direction indicated by arrowed line E in FIG. 8, normal to groove 37. The shape of tongue 67 limits movement of tongue within groove 37 in any direction other than a direction longitudinal to groove 37. Tongue base 71 is wider than groove opening 42 preventing tongue 67 from being removed from groove 37 upward through groove opening 42. Groove 37 also prevents rotation of platform 60 about tongue 67 in directions indicated by double-arrowed lines F and G in FIG. 5. Walls 44 and 45 of groove 37, formed in top end 31 of corbel 30 hold tongue 67 and hold platform 60 flat and level with respect to top end 31.

[0052] Horizontal surface 22, applied against bottom surface 66 of platform 60, prevents rotation of platform 60 about

tongue 67. Horizontal surface 22 operates to prevent movement of platform 60 and secure platform 60 and corbel 30 to vertical surface 21 of support 20. Attachment point 46 at rear end 36 of corbel 30 cooperates with platform 60 positioned concurrently on and supported concurrently by horizontal surface 22 of support 20 and top end 31 of corbel 30 to secure corbel 30 and platform 60 to support 20. Attachment point 46 and bottom surface 66 positioned against horizontal surface 22 create a stable attachment to support 20, providing two points of contact and support which prevent movement or rotation of platform 60 and corbel 30 with respect to support 20.

[0053] Corbel 30 further resists rotational movement of platform 60 with respect to outward support corner 23. Rear end 36 of corbel 30 is applied against vertical surface 21 of support 20, providing a large area of contact against vertical surface 21, thereby preventing rotation with respect to outward support corner 23 as indicated by double-arrowed line H in FIG. 7 along the entire length of rear end 35 in juxtaposition with vertical surface 21. Interlocking tongue 67 and groove 37 provide rigidity along front end 61 of platform 60 and top end 31 of corbel 30, mating top end 31 to bottom surface 66 between front end 35 and rear end 36 of corbel 30 and between front end 61 and rear end 62 of platform to resist flexing along line H, which, combined with the rigidity and resiliency of the material of corbel 30, act to resist rotation of platform 60 with respect to outward support corner 23. Further, tongue top 70, tongue base 71, wall 72, and wall 73 form, in sectional profile, a structure similar to a box girder which resists torsion as well as flexion longitudinally with respect to tongue 67.

[0054] Support 20 is a rigid, solid structure, and corbel 30 is constructed of a rigid, resilient material unlikely to deform, creating a solid, stable support for platform 60. Platform 60 coupled to corbel 30 forms a cantilever projecting outward from vertical surface 21, fixed at attachment point 46 and free of attachment at front end 61 of platform 60 and front end 35 of corbel 30. A distributed load applied to platform 60, such as a plant received on top surface 65 of platform 60, is supported at attachment point 46 and along rear end 36 of corbel 30 in juxtaposition with vertical surface 21. Downward forces on front end 61 of platform 60 from items received on platform 60 are distributed through corbel 30 to support 20, thereby preventing platform 60 from flexing along line H. By distributing weight applied to platform 60, corbel acts like a large lever arm supporting platform 60 at support 20 along rear end 36 of corbel 30 in contact with vertical surface 21 of support 20, biasing against downward and rotational forces.

[0055] Despite the effect that contact and friction have to prevent platform 60 from slipping off of corbel 30, platform 30 can be removed from corbel 30 by taking up platform by hand, applying force, and withdrawing tongue 67 from groove 37 in a direction longitudinal with respect to groove 37. Complete removal is accomplished in this manner and by reversing the steps described above for applying platform 60 to corbel 30.

[0056] Turning now to FIG. 11, a corbelled-support apparatus 100 is illustrated. Corbelled-support apparatus 100 is substantially identical to corbelled-support apparatus 19 of FIGS. 1-10 except for a few differences which will be explained below. Corbelled-support apparatus 100 includes vertical surface 21 of support 20, corbel 30, and a platform

160. Platform **160** is structured to receive and support display items with respect to corbel **30** and vertical surface **21** of support **20**.

[0057] Corbel **30** displayed in FIG. **11** is identical to corbel **30** displayed in FIGS. **1-10**. Platform **160** of FIG. **11** is substantially identical to platform **60** displayed in FIGS. **1-10**. Platform **160** has opposed front and rear ends **161** and **162**, opposed sides **163** and **164**, sidewall **175**, and bottom surface **166**. Unlike platform **60**, in which sidewall **75** is continuously arcuate along side **63**, front end **61**, side **64**, rear end **62**, and side **64**, sidewall **175** of platform **160** is continuously arcuate along side **163**, front end **161**, and side **164**. Sidewall **175** along rear end **162** is straight. Otherwise, platform **160** is substantially identical to platform **60**.

[0058] A tongue **167** is formed on platform **160** and is substantially identical to tongue **67** of FIGS. **1-10**, and is shown in FIG. **12**. Tongue **167** is formed along bottom surface **166** of platform **160** extending away from bottom surface **166**. Tongue **167** includes opposed leading and trailing ends **168** and **169** and extends along bottom surface **166** from leading end **168** proximate to rear end **162** of platform **160** to trailing end **169** proximate to front end **161** of platform **160**. Tongue **167** further extends along bottom surface **166** at an intermediate location with respect to opposed sides **163** and **164** of platform **160**.

[0059] Corbel **30** is secured to vertical surface **21** of support **20** along rear end **36** of corbel **30**. A receiving area **190** is formed by and between vertical surface **21** of support **20** and top end **31** of corbel **30** to receive platform **160**. Platform **160** is received in receiving area **190** by sliding tongue **167** into and along groove **37**. Tongue **167** and groove **37** are complementary engagement elements of an engagement assembly formed between platform **160** and corbel **30** which slideably and releasably couple and secure platform **160** to top end **31** of corbel **30**.

[0060] Platform **160** is applied to corbel **30** such that bottom surface **166** of platform **160** is received in juxtaposition against top end **31** of corbel **30** and tongue **167** engages groove **37**. Tongue **167** is concealed by corbel **30** between leading and trailing ends **168** and **169**, such that leading end **168** of tongue **167** is located proximate to rear end **36** of corbel **30** and trailing end **169** is located proximate to front end **35** of corbel **30**. Leading end **168** is further received in juxtaposition with respect to vertical surface **21** of support **20**, limiting movement of platform **160** in a direction longitudinal with respect to groove **37** toward support **20**. Even though groove **37** has opening **41** formed at rear groove end **39**, platform **160** can not be advanced toward support **20** once leading end **168** of tongue **167** encounters vertical surface **21** of support **20**. Platform **160** can be withdrawn from corbel **30** in a direction toward opening **40**, however.

[0061] Turning now to FIG. **13**, a corbelled-support apparatus **200** is illustrated. Corbelled-support apparatus **200** is exactly identical to corbelled support apparatus **19** of FIGS. **1-10** except for a few differences which will be explained below. Corbelled-support apparatus **200** includes a support **20**, a platform **260**, a corbel **30**, and a second corbel **230** identical to corbel **30**. Support **20** has vertical surface **21** and horizontal surface **22**.

[0062] In corbelled-support apparatus **200**, platform **260** is substantially identical to platform **60** of FIGS. **1-10**. Platform **260** has opposed front and rear ends **261** and **262**, opposed sides **263** and **264**, a sidewall **275**, and a bottom surface **266**. Bottom surface **266** of platform **260** is formed with a tongue

267. Platform **260** is rectangular. Front end **261** is longitudinal with respect to rear end **262**, side **263** is longitudinal with respect to side **264**, and front and rear ends **261** and **262** are transverse with respect to sides **263** and **264**.

[0063] Corbel **30** and corbel **230** are identical except in location. Corbel **30** is proximate to side **263** of platform **60**. Tongue **67** extends along bottom surface **266** of platform **260** proximate and longitudinal to side **263** from front end **261** to rear end **262** of platform **260**. Corbel **230** is proximate to side **264** of platform **260**. Tongue **267** is identical to tongue **67** and located proximate and longitudinal to side **264**, extending from front end **261** to rear end **262** of platform **260**. Like corbel **30**, corbel **230** has a groove **237** formed along a top end **231** of corbel **230**. Tongue **267** is applied to and received by groove **237**, coupling platform **260** to corbel **230**. Tongue **267** and groove **237** cooperate as complementary engagement elements of an engagement assembly. Platform **260** is slideably and releasably coupled to corbels **30** and **230** to fix and secure platform **260** to corbels **30** and **230** and to support **20**. Platform **260** is received and supported concurrently on and against horizontal surface **22** of support **20** and top ends **31** and **231** of corbels **30** and **230**, respectively.

[0064] Having fully described the invention in such clear and concise terms as to enable those skilled in the art to understand and practice the same, the invention claimed is:

1. A corbelled-support apparatus, comprising:
 - a support including a horizontal surface and a vertical surface;
 - a corbel including opposed top and bottom ends, the corbel secured to the vertical surface of the support;
 - a platform positioned concurrently on and supported concurrently by the horizontal surface of the support and the top end of the corbel; and
 - the platform for receiving and supporting display items with respect to the horizontal surface of the support and the corbel.
2. The corbelled-support apparatus of claim 1, further comprising an engagement assembly coupling the platform to the corbel comprising an engagement element carried by the platform and a complementary engagement element carried by the corbel.
3. The corbelled-support apparatus of claim 2, further comprising:
 - the engagement element is one of a tongue and a groove; and
 - the complementary engagement element is the other of the tongue and the groove.
4. The corbelled-support apparatus of claim 2, further comprising:
 - the platform includes opposed front and rear ends, opposed sides, and opposed top and bottom surfaces;
 - the engagement element is a tongue;
 - the complementary engagement element is a groove;
 - the tongue includes opposed leading and trailing ends;
 - the tongue extends along the bottom surface of the platform from the leading end located between front and rear ends of platform to the trailing end positioned near the front end of the platform.
5. The corbelled-support apparatus of claim 4, further comprising:
 - an area of the vertical surface of the support exposed at the groove inboard with respect to the top end of the corbel; and

the leading end of the tongue extending along the bottom surface of the platform is encountered by and received in juxtaposition with respect to the area of the vertical surface of the support exposed at the groove.

6. The corbelled-support apparatus of claim **5**, further comprising:

the corbel is rigidly secured to the vertical surface of the support at a point of attachment;

the point of attachment is located at an intermediate position with respect to the top and bottom ends of the corbel; and

the point of attachment cooperates with the platform positioned concurrently on and supported concurrently by the horizontal surface of the support and the top end of the corbel to secure the corbel and the platform to the support.

7. The corbelled-support apparatus of claim **6**, further comprising:

the leading end of the tongue cooperates with the bottom surface of the platform to form an inward platform corner;

the horizontal and vertical surfaces of the support meet at an outward support corner; and

the inward platform corner receives the outward support corner, the leading end of the tongue received in juxtaposition with the vertical surface of the support at the area of the vertical surface of the support exposed at the groove.

8. The corbelled-support apparatus of claim **7**, wherein the tongue is concealed by the corbel between the leading and trailing ends of the tongue.

9. The corbelled-support apparatus of claim **8**, wherein the tongue further extends along the bottom surface of the platform at an intermediate position with respect to the opposed sides of the platform.

10. The corbelled-support apparatus of claim **8**, further comprising:

a second corbel secured to the vertical surface of the support;

a second engagement assembly coupling the platform to the second corbel comprising a second engagement element carried by the platform and a second complementary element carried by the second corbel;

the second engaging element extends along the bottom surface of the platform at a position proximate to one of the sides of the platform; and

the tongue extends along the bottom surface of the platform at a position distal to the one of the sides of the platform.

11. A corbelled-support apparatus, comprising:

a platform;

a corbel;

an engagement assembly coupling the platform to the corbel comprising an engagement element carried by the platform and a complementary engagement element carried by the corbel;

a receiving area formed by and between the platform and the corbel to receive a support having a horizontal surface and a vertical surface;

the support received in the receiving area;

the corbel secured to the vertical surface of the support; and
the platform supported by the horizontal surface of the support, the platform for receiving items thereon for display with respect to the support.

12. The corbelled-support apparatus of claim **11**, further comprising:

the platform includes opposed top and bottom surfaces; the engagement element is carried by the bottom surface of the platform;

the corbel includes opposed top and bottom ends; and the complementary engagement element is carried by the top end of the corbel.

13. The corbelled-support apparatus of claim **12**, further comprising:

the engagement element is one of a tongue and a groove; and

the complementary engagement element is the other of the tongue and the groove.

14. The corbelled-support apparatus of claim **12**, further comprising:

the platform includes opposed front and rear ends and opposed sides;

the engagement element is a tongue;

the complementary engagement element is a groove;

the tongue includes opposed leading and trailing ends;

the tongue extends along the bottom surface of the platform from the leading end located at an intermediate position with respect to the bottom surface to the trailing end positioned near the front end of the platform.

15. The corbelled-support apparatus of claim **14**, wherein the tongue is concealed by the corbel between the leading and trailing ends of the tongue.

16. The corbelled-support apparatus of claim **14**, where the tongue further extends along the bottom surface of the platform at an intermediate position with respect to the opposed sides of the platform.

17. The corbelled-support apparatus of claim **16**, further comprising:

a first portion of the platform positioned between the opposed sides of the platform, and extending from the front end of the platform to an intermediate location of the platform between the opposed front and rear ends of the platform;

a second portion of the platform positioned between the opposed sides of the platform, and extending from the rear end of the platform to an intermediate location of the platform between the opposed front and rear ends of the platform;

the first portion of the platform supported by the corbel; and

the second portion of the platform supported by the horizontal surface of the support.

18. The corbelled-support apparatus of claim **17**, further comprising:

the corbel is rigidly secured to the vertical surface of the support at a point of attachment;

the point of attachment is located at an intermediate position with respect to the top and bottom ends of the corbel; and

the point of attachment cooperates with the second portion of the platform supported by the horizontal surface of the support to secure the corbel and platform to the support.

19. The corbelled-support apparatus of claim **18**, further comprising:

the leading end of the tongue cooperates with the bottom surface of the platform to form an inward platform corner;

the horizontal and vertical surfaces of the support meet at an outward support corner; and

the inward platform corner receives the outward support corner, the leading end of the tongue received in juxtaposition with the vertical surface of the support.

20. A corbelled-support apparatus, comprising:

a support including a vertical surface;

a corbel including opposed top and bottom ends, the corbel secured to the vertical surface of the support;

a receiving area formed by and between the vertical surface of the support and the top end of the corbel to receive a platform having a bottom surface;

the platform received in the receiving area;

an engagement assembly formed between and coupling the platform to the corbel comprising an engagement element carried by the bottom surface of the platform and a complementary engagement element carried by the corbel, the engagement element slidably and releasably coupling the complementary engagement element releasably securing the platform to the top end of the corbel;

the engagement element is a tongue;

the complementary engagement element is a groove;

the tongue includes opposed leading and trailing ends;

the tongue extends along the bottom surface of the platform from the trailing end between the opposed front and rear ends of the platform and extends along the bottom surface to the leading end at an intermediate position with respect to the opposed sides of the platform;

the tongue is concealed by the corbel between the leading and trailing ends of the tongue;

the leading end of the tongue is received in juxtaposition with respect to the vertical surface of the support, limiting movement of the tongue toward the support;

the groove includes opposed open ends;

the corbel is rigidly secured to the vertical surface of the support at a point of attachment;

the point of attachment is located at an intermediate position with respect to the top and bottom ends of the corbel;

the point of attachment cooperates with the platform positioned concurrently on and against the vertical surface of the support and the top end of the corbel to secure the corbel and the platform to the support; and

the platform for receiving and supporting display items with respect to the corbel and the vertical surface of the support.

* * * * *