



US 20170215518A1

(19) **United States**

(12) **Patent Application Publication**

Curl et al.

(10) **Pub. No.: US 2017/0215518 A1**

(43) **Pub. Date: Aug. 3, 2017**

(54) **CLEATS, CLEATED SOLE STRUCTURES, MOLDS AND MOLDING METHODS FOR IN-MOLDING ARTICLES**

A43B 13/12 (2006.01)
A43B 13/26 (2006.01)

(52) **U.S. Cl.**
CPC *A43B 5/001* (2013.01); *A43B 13/122* (2013.01); *A43B 13/26* (2013.01); *A43C 15/161* (2013.01); *A43C 15/162* (2013.01); *B29D 35/128* (2013.01); *B29D 35/142* (2013.01); *B29D 35/148* (2013.01); *A43C 15/16* (2013.01)

(71) Applicant: **NIKE, Inc.**, Beaverton, OR (US)

(72) Inventors: **Darien Curl**, Beaverton, OR (US); **Dick Lin**, Beaverton, OR (US); **Nicole Mueller**, Portland, OR (US); **Ricardo Salinas, JR.**, Hillsboro, OR (US); **David Tu**, Beaverton, OR (US)

(21) Appl. No.: **15/488,726**

(22) Filed: **Apr. 17, 2017**

Related U.S. Application Data

(63) Continuation of application No. 13/759,893, filed on Feb. 5, 2013.

Publication Classification

(51) **Int. Cl.**
A43B 5/00 (2006.01)
B29D 35/14 (2006.01)
A43C 15/16 (2006.01)
B29D 35/12 (2006.01)

(57) **ABSTRACT**

Cleat structures, e.g., for golf shoes, may include a flat and flexible interior surface and/or a generally disk-shaped perimeter area that includes features to promote in-molding of the cleat to a footwear sole component (e.g., to permanently engage the cleat with an outsole member). Such cleats may provide a flexible and comfortable base, including a low profile, e.g., to enable formation relatively thin and/or flexible footwear sole components. Footwear sole components and articles of footwear that include one or more in-molded cleat structures of this type also are described. Molds used for in-molding procedures and methods of using the molds to make articles with in-molded components (e.g., for making footwear sole structures including one or more in-molded cleats) also are described.

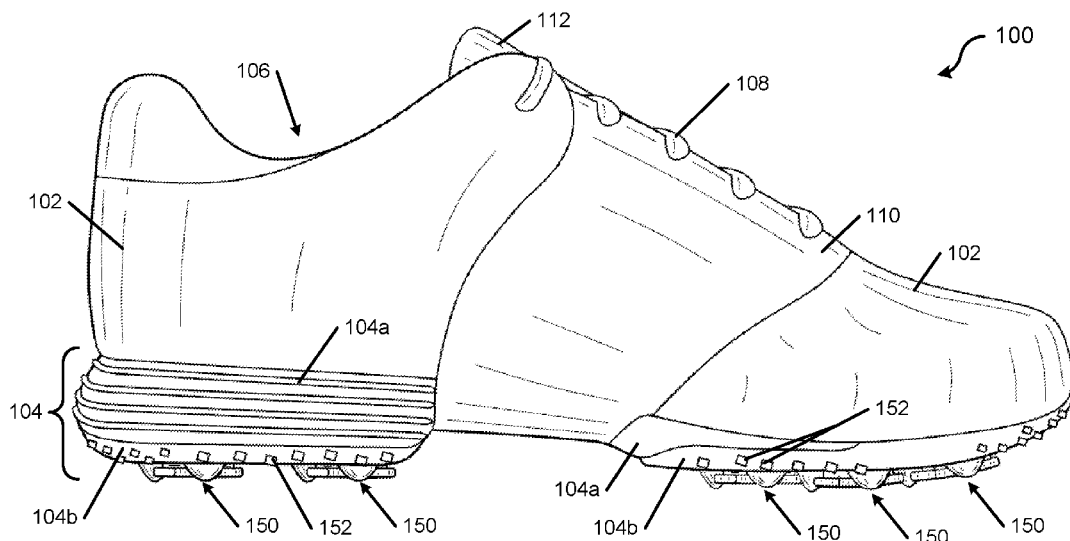
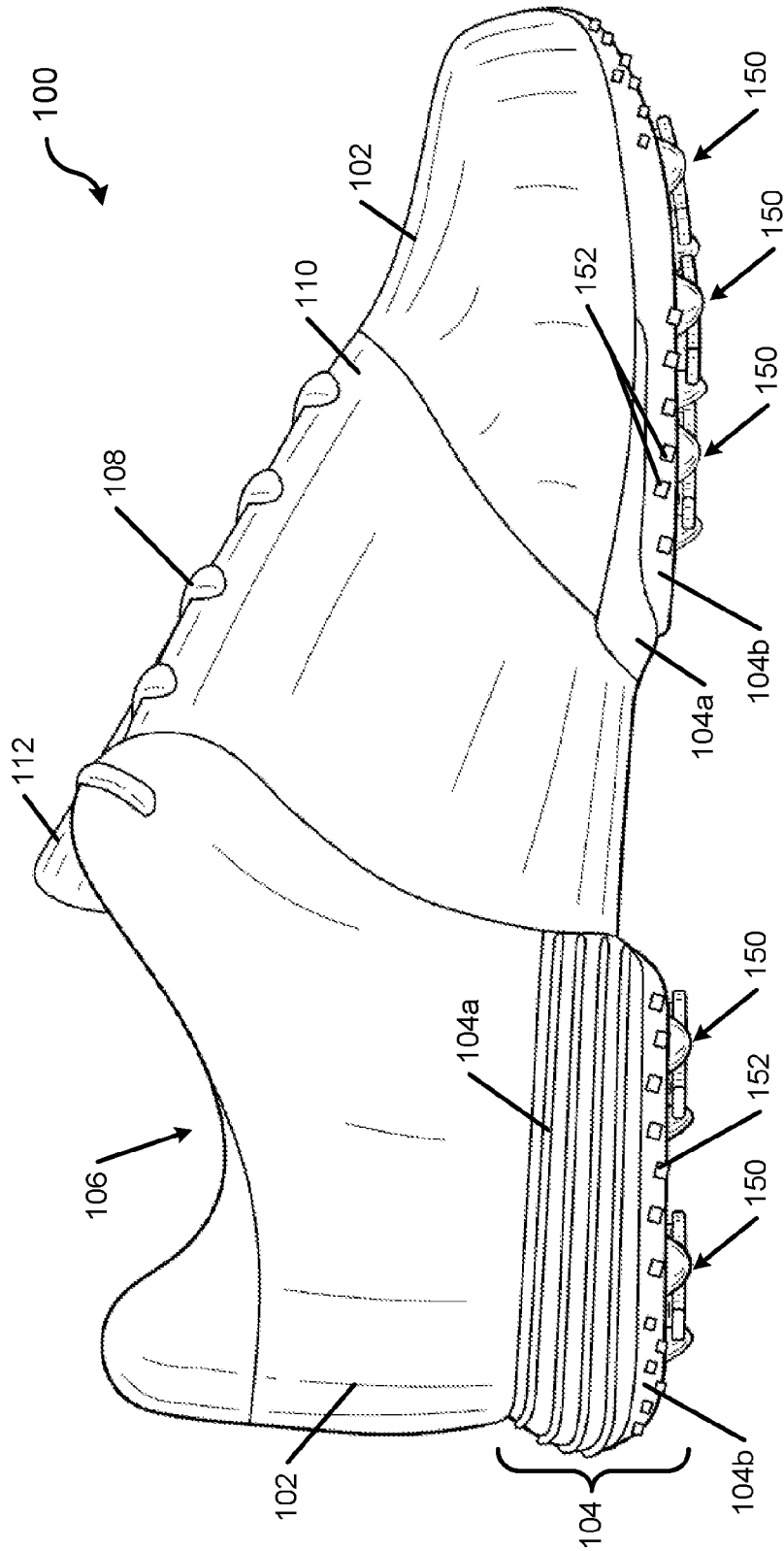

FIG. 1A



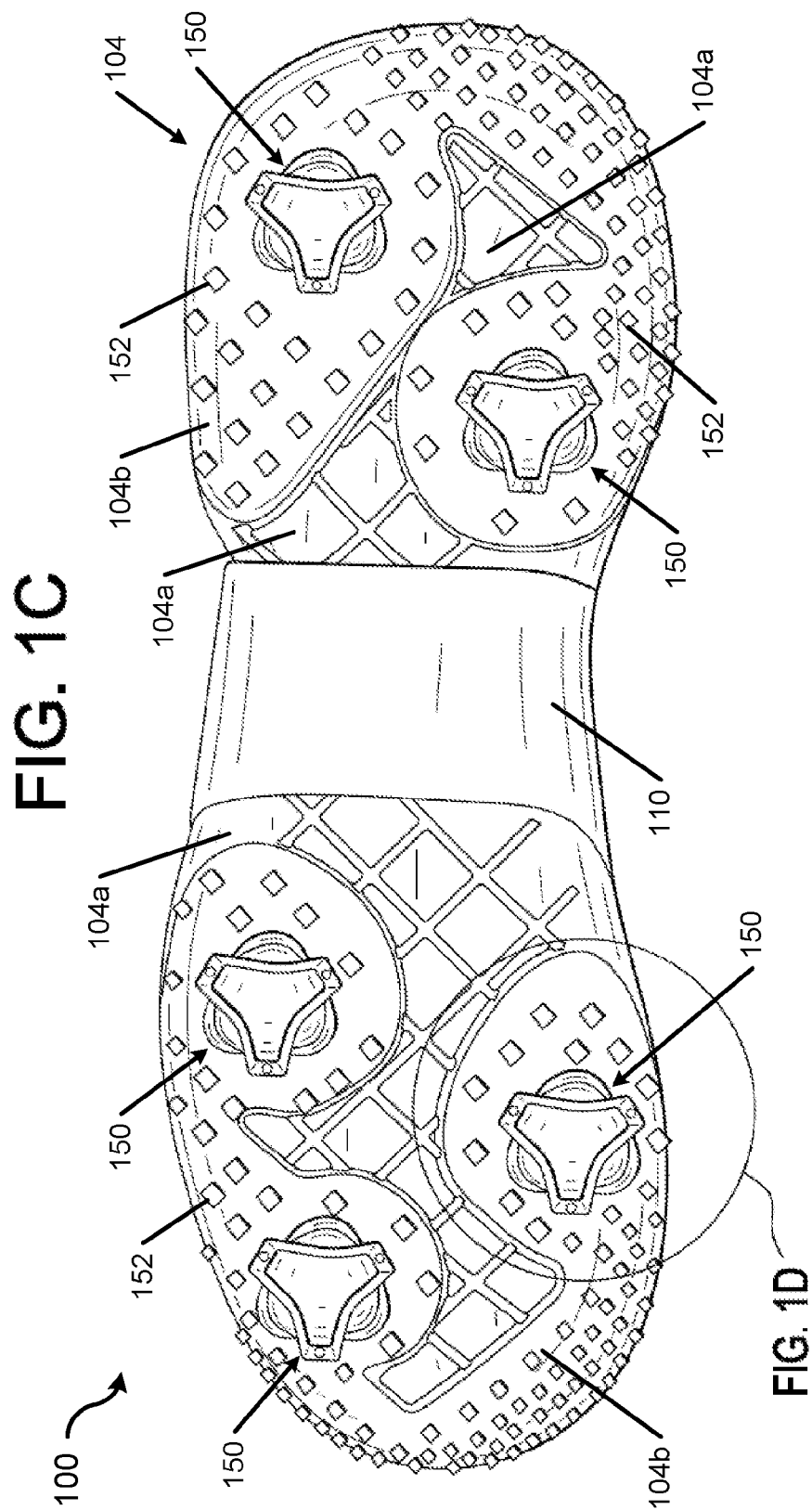

FIG. 1C

FIG. 1D

FIG. 1D

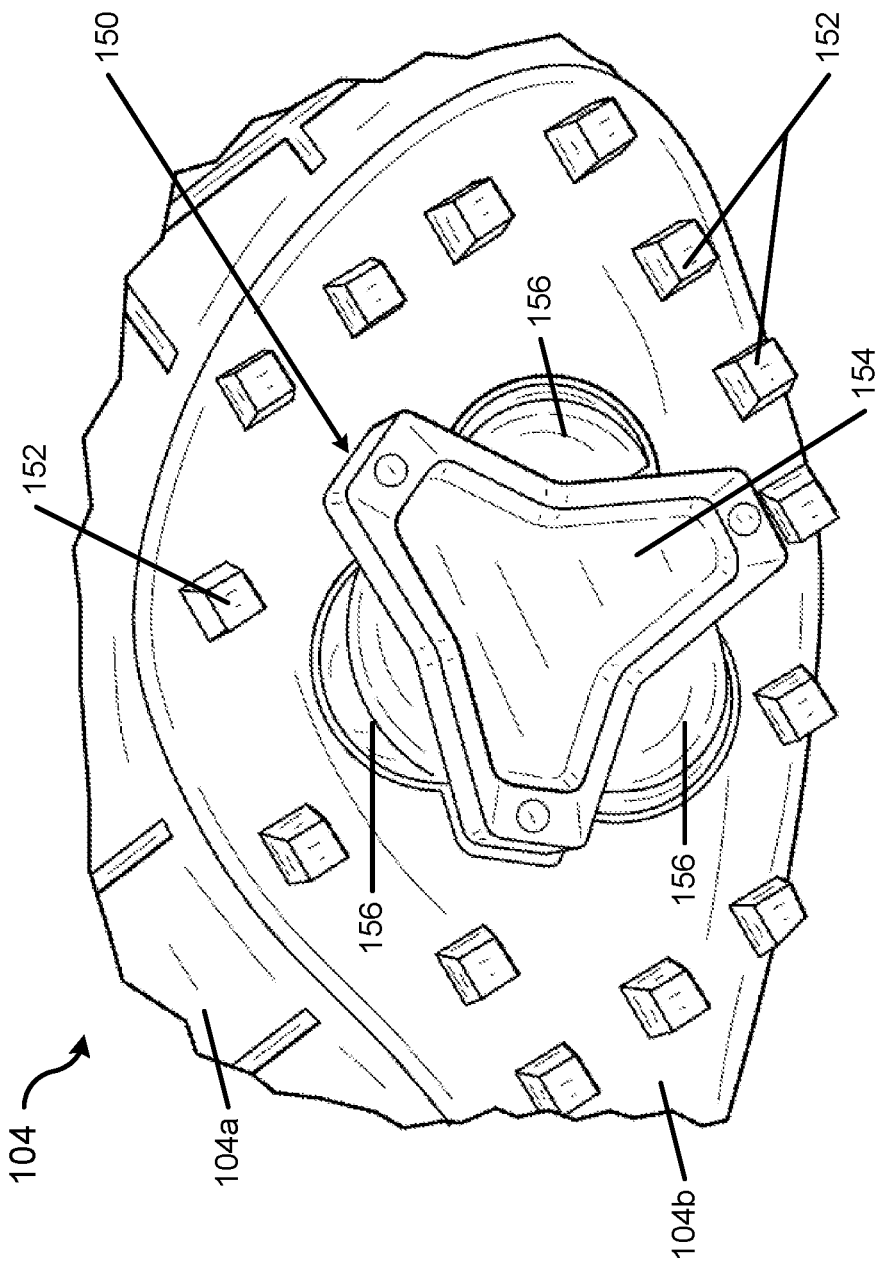

FIG. 2A

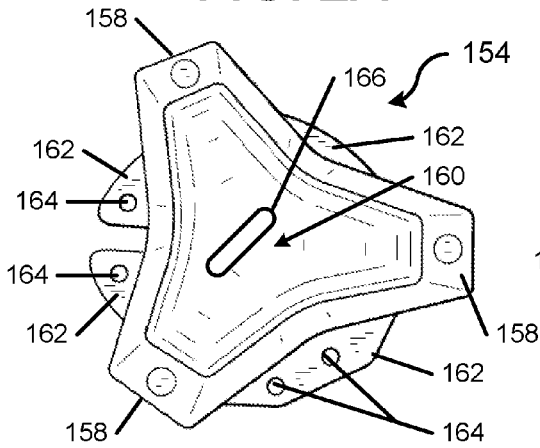

FIG. 2B

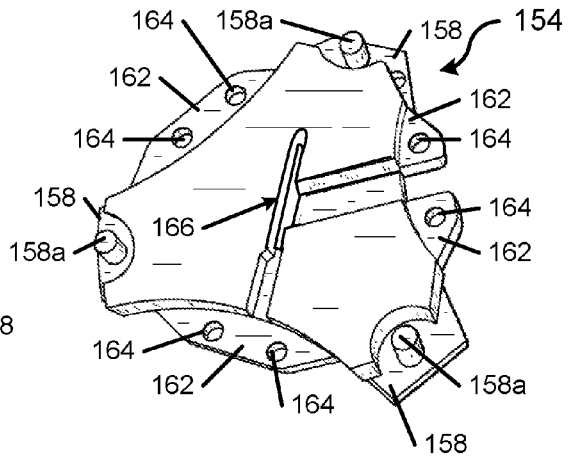

FIG. 2E

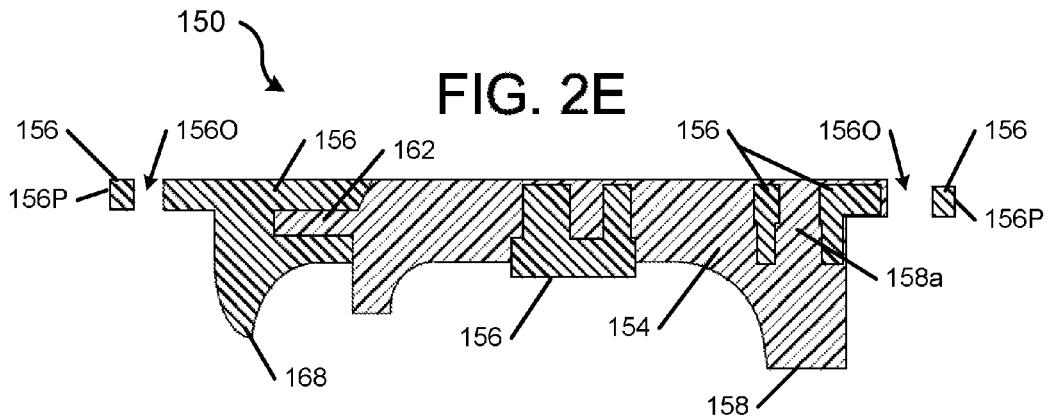

FIG. 2D

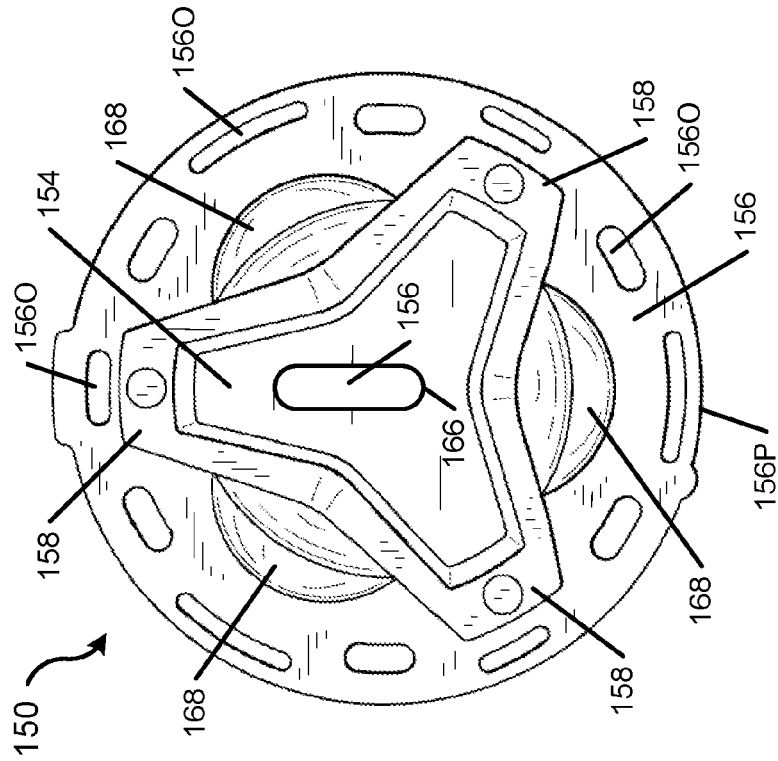

FIG. 2C

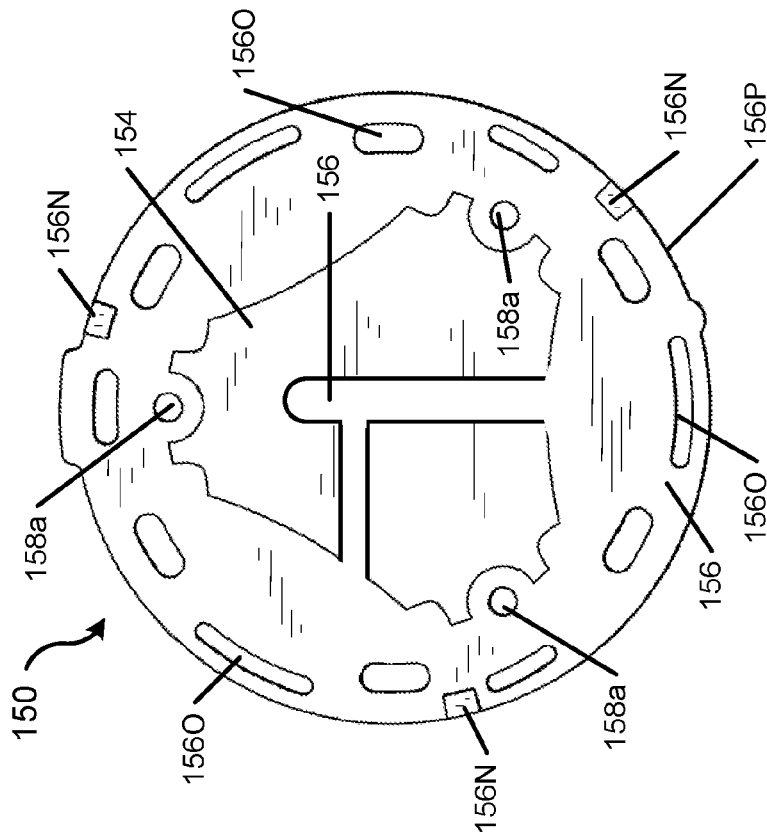

FIG. 3A

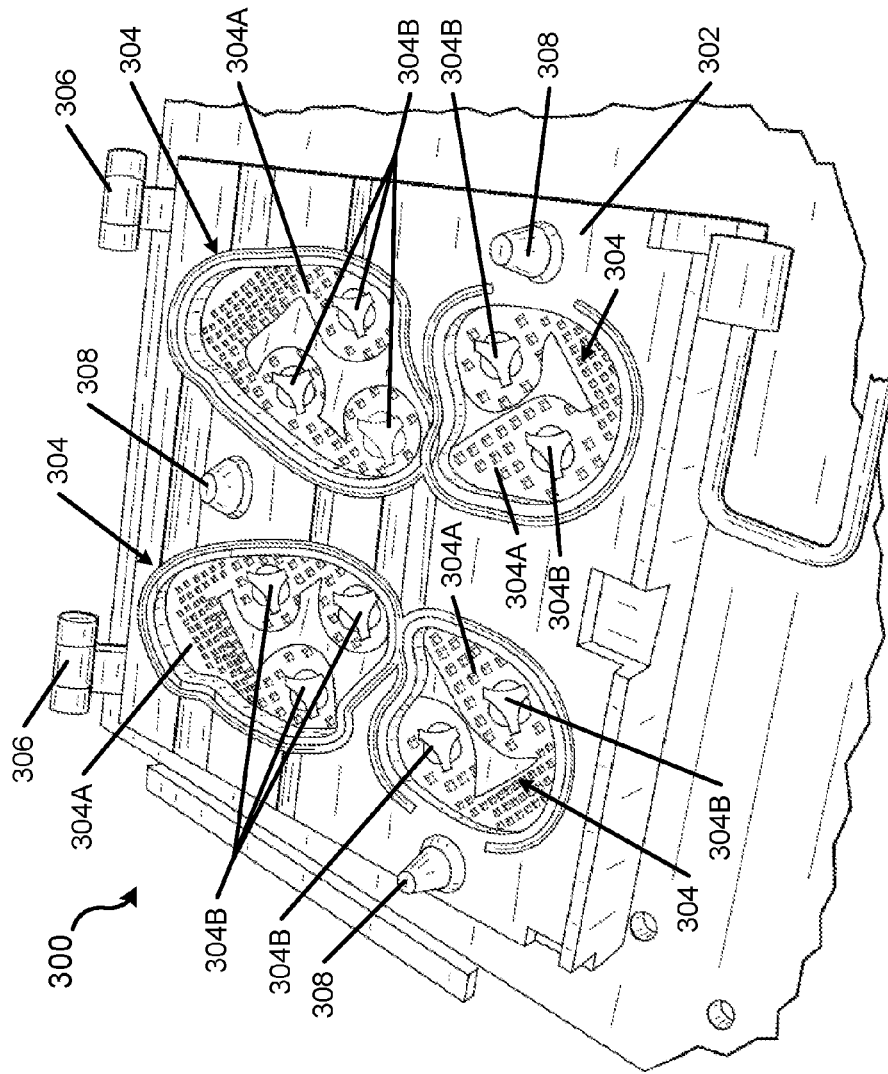

FIG. 3B

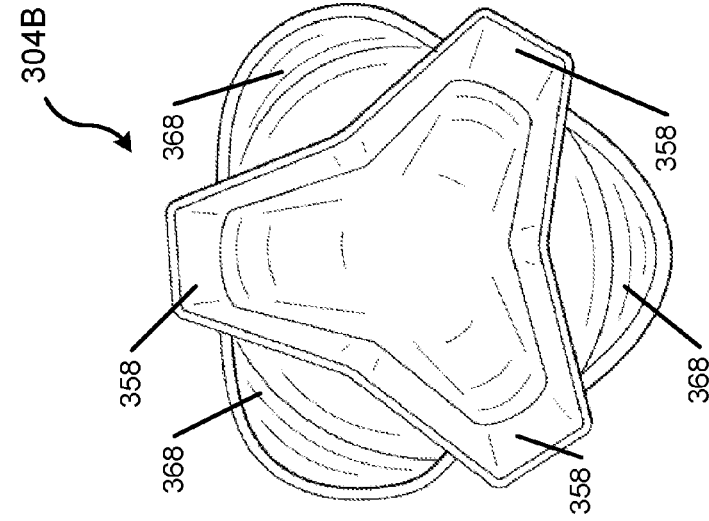

FIG. 3C

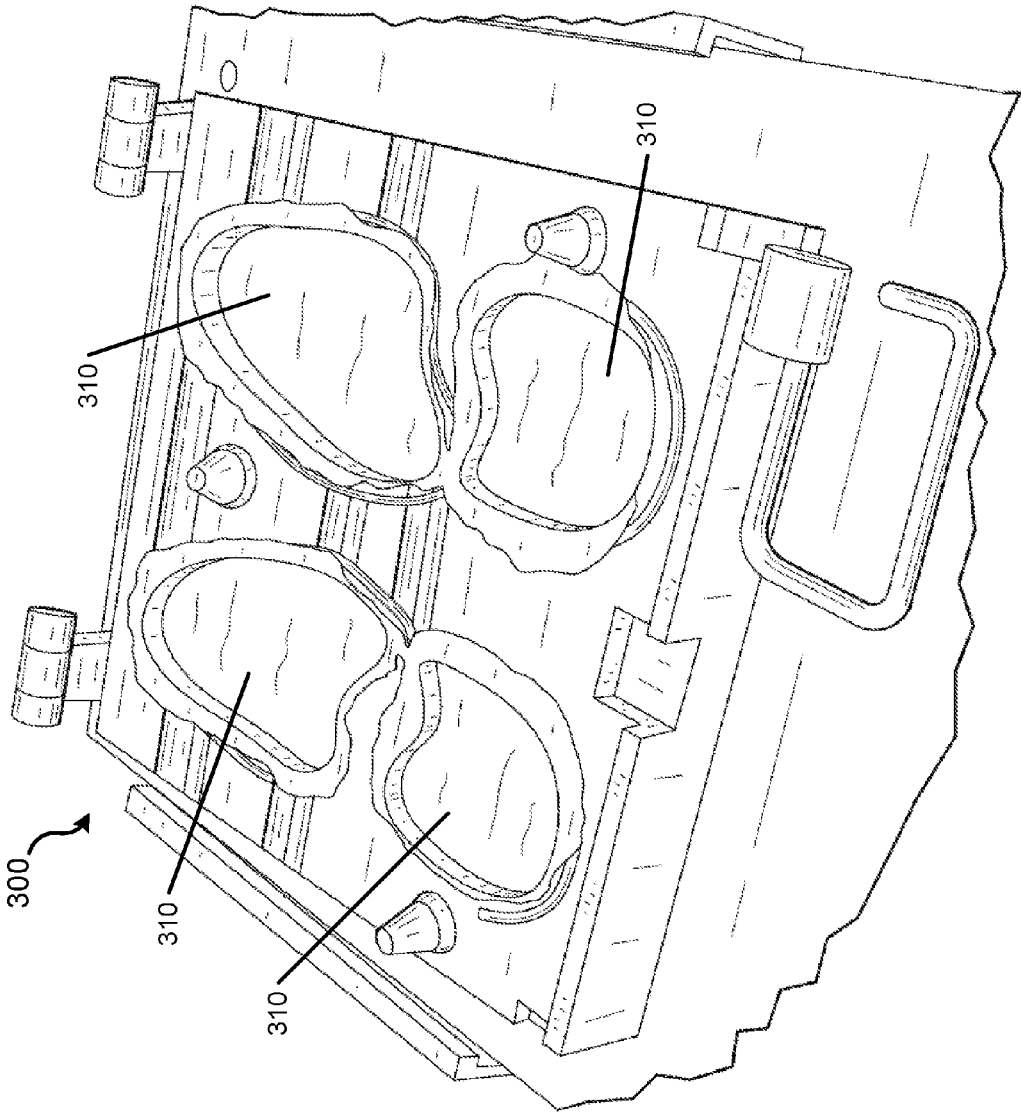

FIG. 3D

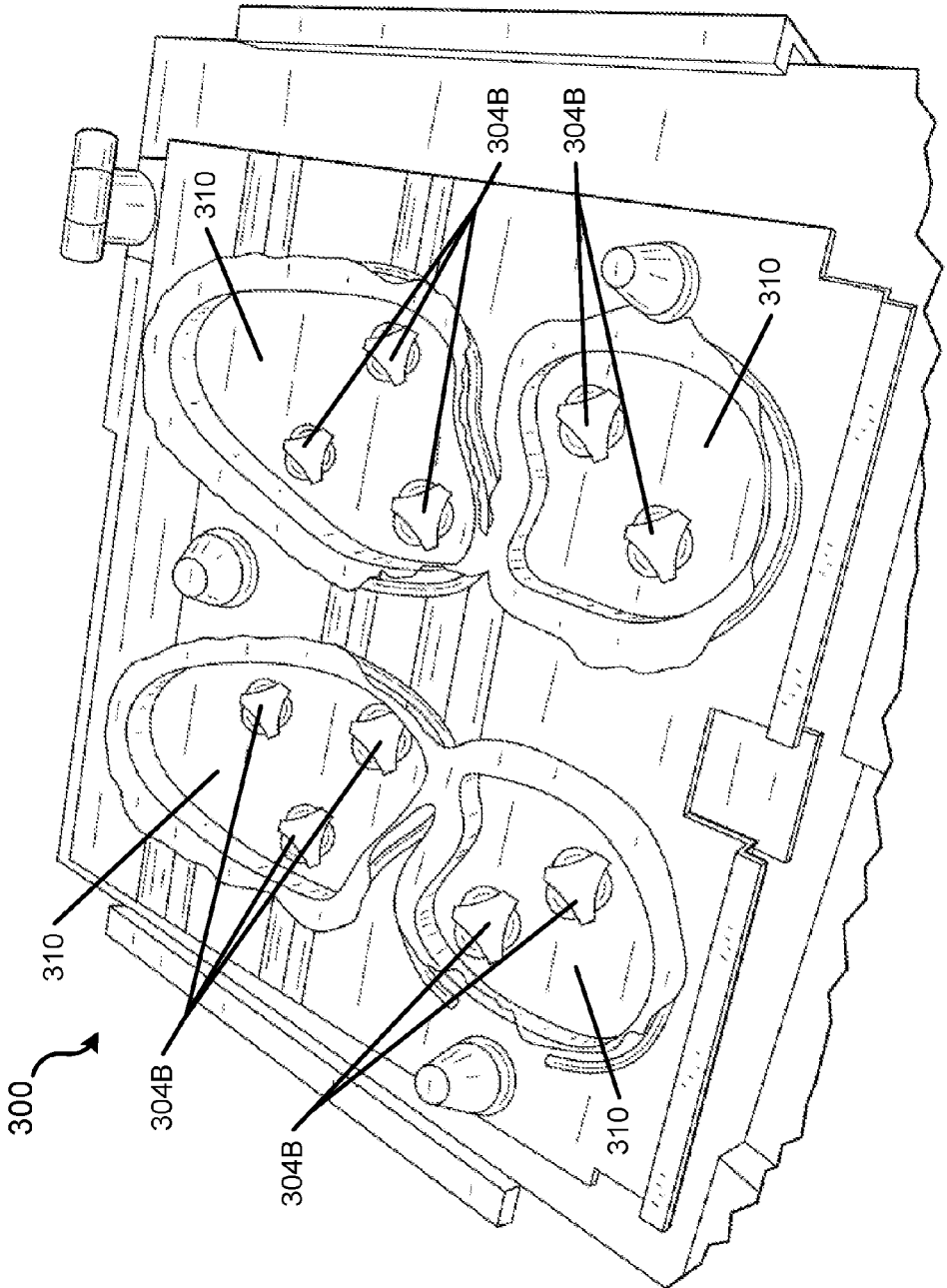

FIG. 3E

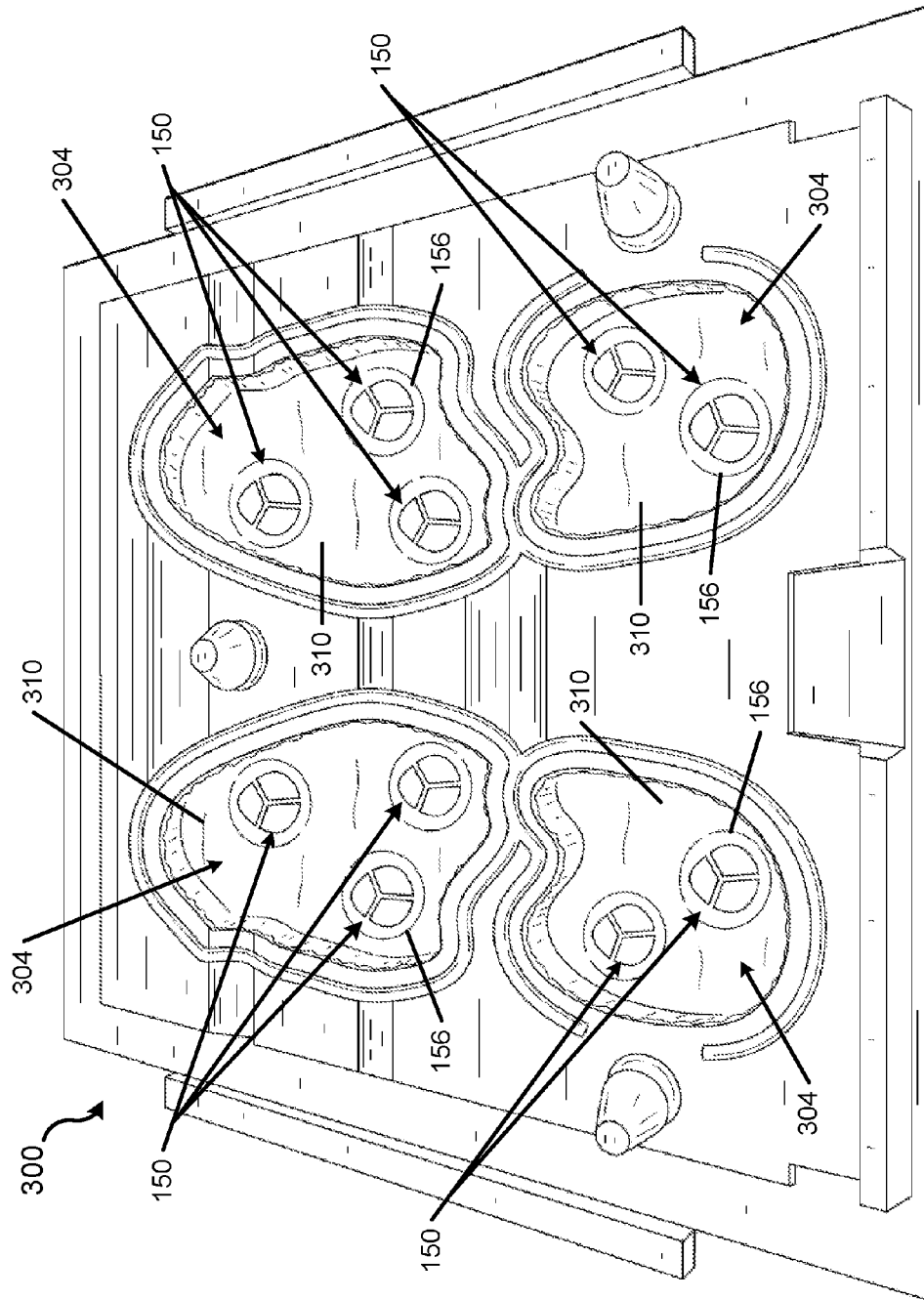

FIG. 3F

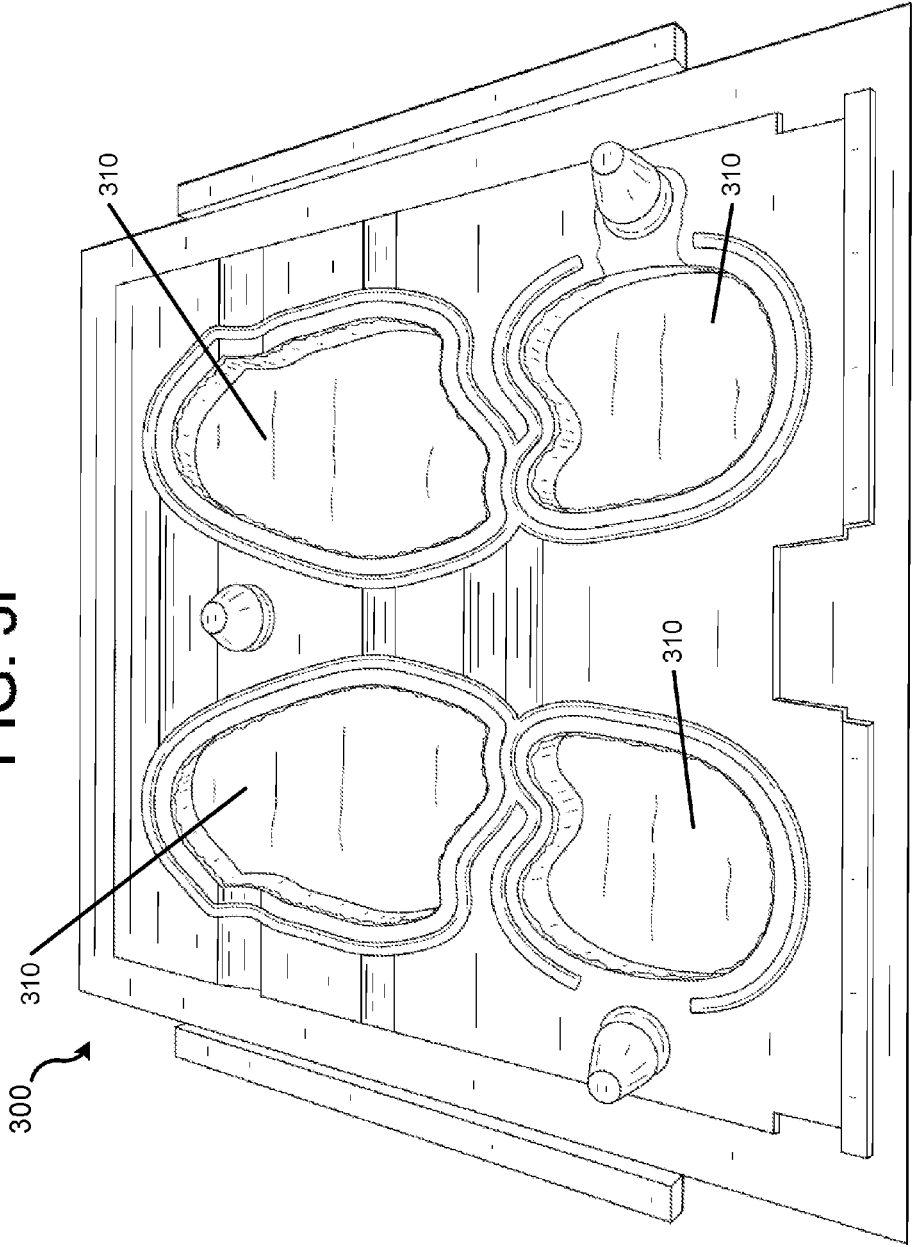

FIG. 3G

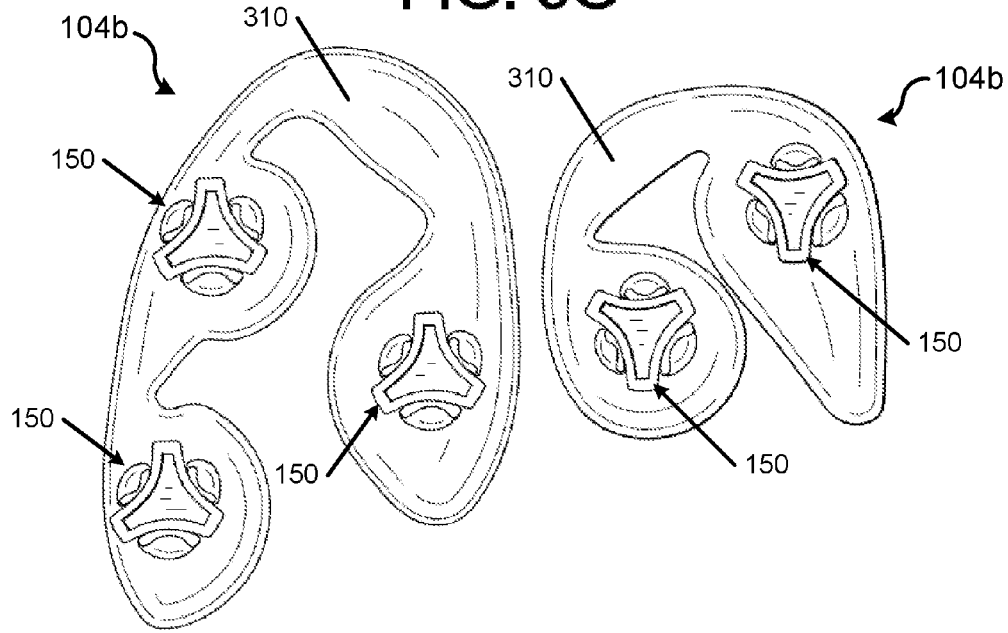

FIG. 3H

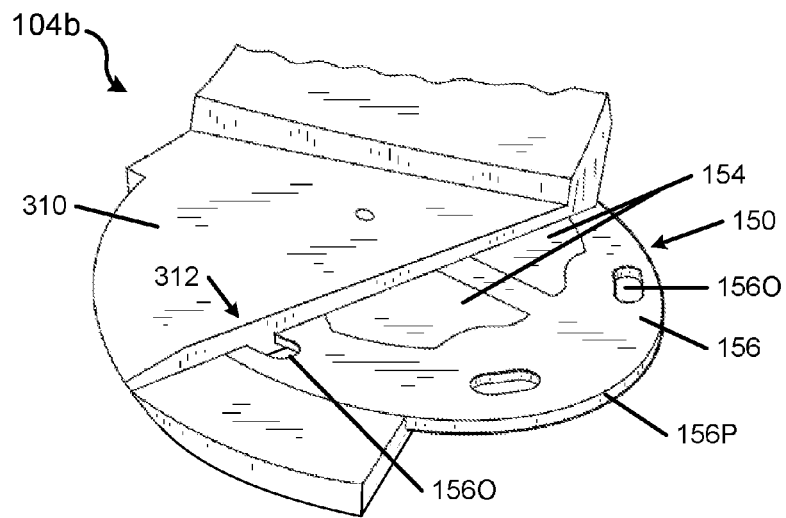

FIG. 4A

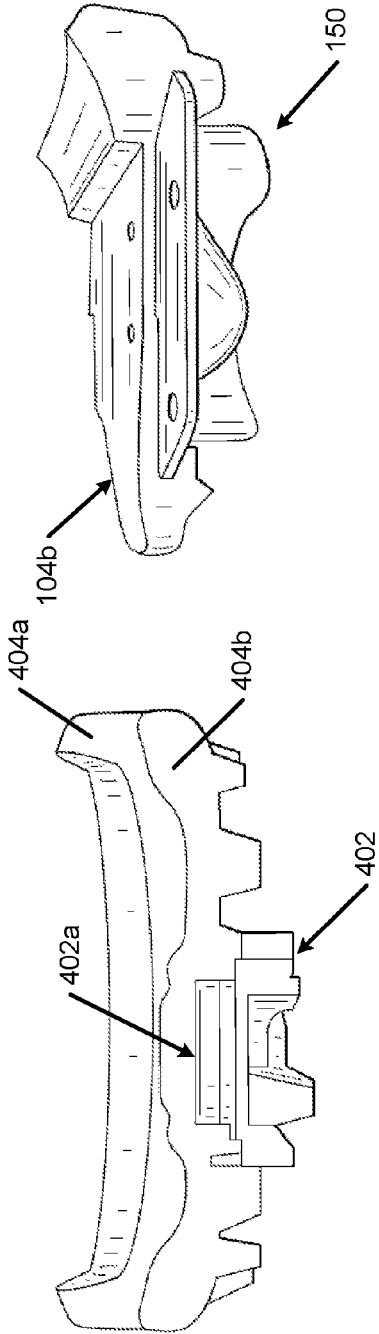

FIG. 4C

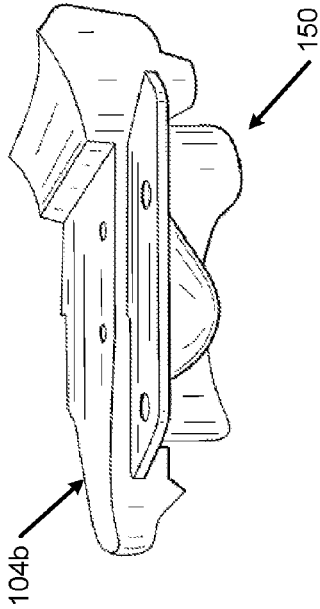

FIG. 4B

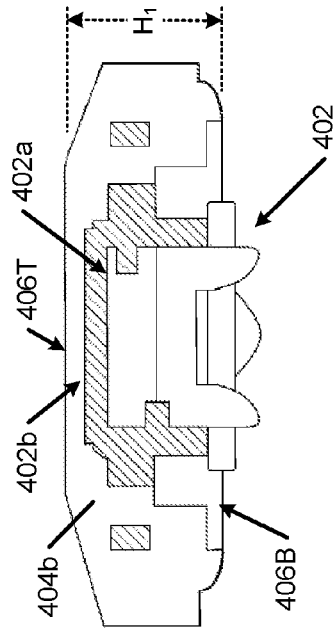
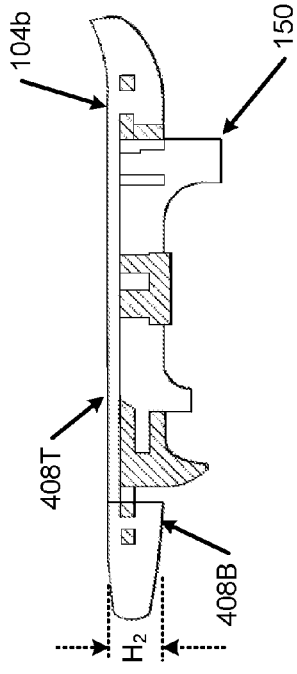

FIG. 4D



CLEATS, CLEATED SOLE STRUCTURES, MOLDS AND MOLDING METHODS FOR IN-MOLDING ARTICLES

RELATED APPLICATION DATA

[0001] This application is a continuation of co-pending U.S. patent application Ser. No. 13/759,893, filed Feb. 5, 2013 and entitled "Cleats, Cleated Sole Structures, Molds, and Molding Methods for In-Molding Articles." U.S. patent application Ser. No. 13/759,893 is entirely incorporated herein by reference.

FIELD OF THE INVENTION

[0002] The present invention in part relates to the field of footwear. More specifically, some aspects of the present invention pertain to cleat structures, sole structures including such cleat structures, and articles of footwear (e.g., athletic footwear) that include such sole structures. Additional aspects of this invention relate to molds and methods of molding articles that may be used, for example, to produce articles with in-molded structures, including footwear sole structures with in-molded cleats.

BACKGROUND

[0003] Conventional golf shoes and other articles of footwear often include cleat structures or other traction enhancing elements to improve traction and provide a stable base for activities performed by the wearer. Many cleats of this type include a threaded connector or a turnbuckle type engagement structure to allow the cleat to be releasably engaged with a footwear sole structure. While useful to releasably engage the cleat with the shoe, such connector structures have certain disadvantages. For example, the treaded connector or turnbuckle type engagement structures typically extend toward the bottom (plantar) surface of the wearer's foot. Therefore, when the wearer stands and walks on the shoe, distinct high pressure points often can be felt underfoot, which lead to discomfort and/or fatigue, particularly after walking in the shoes for 18 or more holes of golf (often over terrain of varying slope and hardness).

[0004] Cushioning elements, rigid plates, or other pressure moderator or force dispersing structures may be incorporated into the footwear construction in an effort to reduce the point loading and/or pressure forces experienced by the wearer. Such structures, however, tend to increase the height of the shoe and/or reduce the flexibility and/or natural motion feel of the shoe. Many golfers find these features to be disadvantageous.

[0005] Additionally, the releasable connection between cleats and the sole structure may cause the cleat elements to loosen and become disengaged from the shoe, often without the wearer immediately knowing. Such unintended loss of cleats can adversely impact traction and potentially damage golf course mowing or maintenance equipment.

[0006] Accordingly, there is room in the art for improvements in cleated footwear structures, e.g., for golf shoes and/or other cleated footwear constructions.

SUMMARY OF THE INVENTION

[0007] This Summary is provided to introduce some general concepts relating to this invention in a simplified form that are further described below in the Detailed Description.

This Summary is not intended to identify key features or essential features of the invention.

[0008] Some aspects of this invention relate to cleat structures, e.g., cleats for golf shoes or other cleated footwear. The cleat structures may include a flat interior surface and/or a generally disk-shaped perimeter area that includes structures to promote in-molding of the cleat to a footwear sole component. Such cleats may provide a flexible and comfortable base, e.g., to enable formation relatively thin and/or flexible footwear sole components.

[0009] Additional aspects of this invention relate to footwear sole components (e.g., outsole components) and/or articles of footwear that include one or more in-molded cleat structures, e.g., of the types described above. Still additional aspects of this invention relate to molds used for in-molding procedures and methods of using the molds to make articles with in-molded components (e.g., for making footwear sole structures including one or more in-molded cleats).

BRIEF DESCRIPTION OF THE DRAWINGS

[0010] The foregoing Summary of the Invention, as well as the following Detailed Description of the Invention, will be better understood when considered in conjunction with the accompanying drawings in which like reference numerals refer to the same or similar elements in all of the various views in which that reference number appears.

[0011] FIGS. 1A through 1D illustrate various views of cleat structures, sole structures, and articles of footwear according to examples of this invention;

[0012] FIGS. 2A through 2E illustrate various views of cleat structures according to examples of this invention;

[0013] FIGS. 3A through 3H provide various views illustrating features of mold structures, methods of molding, and molded products according to examples of this invention; and

[0014] FIGS. 4A through 4D provide views comparing a known cleat and sole construction (FIGS. 4A and 4B) with a cleat and sole construction in accordance with one example of this invention (FIGS. 4C and 4D).

DETAILED DESCRIPTION OF THE INVENTION

[0015] In the following description of various examples of structures, components, and methods according to the present invention, reference is made to the accompanying drawings, which form a part hereof, and in which are shown by way of illustration various example structures, environments, and methods in which aspects of the invention may be practiced. It is to be understood that other structures, environments, and methods may be utilized and that structural and functional modifications may be made to the specifically described structures and methods without departing from the scope of the present invention.

I. GENERAL DESCRIPTION OF ASPECTS OF THIS INVENTION

[0016] As noted above, aspects of this invention relate to cleat structures, sole structures including cleat structures, and articles of footwear (e.g., athletic footwear) that include such sole structures. Additional aspects of this invention relate to molds and methods of molding articles that may be

used, for example, to produce articles having in-molded structures or components, including footwear sole structures having in-molded cleats.

[0017] A. Cleat Constructions According to Aspects of this Invention

[0018] Some aspects of this invention relate to cleat constructions that can be incorporated into articles of footwear, such as athletic footwear (and in some specific examples, golf footwear). In some more specific examples, the cleats may be fixed or permanently incorporated into the sole structure of the article of footwear.

[0019] As a more specific example, cleats in accordance with at least some examples of this invention may include: (A) a cleat component made from a first material, wherein the cleat component includes: (i) a first leg having a first anchor post extending from a bottom side of the first leg toward a bottom surface of the cleat component, (ii) a second leg having a second anchor post extending from a bottom side of the second leg toward the bottom surface of the cleat component, and (iii) a third leg having a third anchor post extending from a bottom side of the third leg toward the bottom surface of the cleat component; and (B) a cleat base engaged with the cleat component at the first, second, and third anchor posts, wherein the cleat base is made from a second material that is different from the first material. Two legs or more than three legs may be provided in some cleat structures without departing from this invention.

[0020] Another example of cleats in accordance with at least some aspects of this invention includes: (A) a cleat component made from a first material, wherein the cleat component includes: (i) a first leg, (ii) a second leg, (iii) a third leg, (iv) a first ridge extending between the first and second legs, (v) a second ridge extending between the second and third legs, and (vi) a third ridge extending between the first and third legs; and (B) a cleat base engaged with the cleat component such that a first portion of the cleat base at least partially surrounds the first ridge, a second portion of the cleat base at least partially surrounds the second ridge, and a third portion of the cleat base at least partially surrounds the third ridge, wherein the cleat base is made from a second material that is different from the first material. Other numbers of legs and/or intermediate ridges also may be used (e.g., 2-6 legs and/or intermediate ridges) without departing from this aspect of the invention.

[0021] Yet another example of cleats in accordance with at least some aspects of this invention include: (A) a cleat base including a first surface, a second surface opposite the first surface, and an outer perimeter, wherein the cleat base is made from a first material, and wherein the cleat base includes: (i) a set of perimeter openings extending from the first surface to the second surface and located adjacent the outer perimeter and (ii) a first inner opening at least partially located inside the set of perimeter openings; and (B) a cleat component extending through and/or engaged with the cleat base at the first inner opening, wherein the cleat component is made from a second material that is different from the first material, and wherein the cleat component includes: (i) a first (exterior) surface that includes one or more traction enhancing structures and (ii) a second (interior) surface opposite the first surface. In this example cleat structure, a bottom of the cleat is located inside the outer perimeter of the cleat base, wherein at least 95% of an area of the bottom of the cleat comprises the second surface of the cleat base,

the second surface of the cleat component, and the set of perimeter openings, and wherein at least 95% of a combined surface area of the second surfaces of the cleat base and the cleat component is planar, substantially planar, or smoothly curved.

[0022] In the example cleat structures described above, if desired, the cleat base may be permanently engaged with the article of footwear, e.g., in-molded or otherwise permanently fixed to the sole structure of the shoe (although it may be releasably attached to the article of footwear, if desired). Additionally or alternatively, if desired, the cleat component may be releasably engaged with the cleat base so that the cleat component may be replaced on the cleat base, if desired. In some specific example structures in accordance with this invention, however, the cleat base will be in-molded or otherwise permanently fixed to the sole structure of the shoe (e.g., by cements or adhesives, by mechanical connectors, etc.) and the cleat component will be in-molded or otherwise permanently fixed to the cleat base (e.g., by cements or adhesives, by mechanical connectors, etc.), such that the entire cleat is permanently fixed with the article of footwear (e.g., fixed in a non-replaceable manner).

[0023] In cleat structures in accordance with at least some examples of this invention, the cleat component may include a central opening, and a portion of the cleat base may extend to and/or be exposed to an outer (exterior) surface of the cleat through this central opening. If desired, the portion of the cleat base exposed at the outer surface of the cleat through the central opening may be surrounded by the cleat component. If desired, in the final cleat structure, the material from which the cleat base is formed (e.g., a nylon material) may be harder than the material from which the cleat component is formed (e.g., a thermoplastic polyurethane material). The cleat base may be at least somewhat flexible, and it may be constructed so as to be free from threaded connectors, turnbuckle type connectors, and/or other structures for releasably engaging the cleat with an article of footwear. If the cleat base is flexible, this may help allow the cleat to feel more comfortable underfoot (e.g., to better conform with the foot shape). This flexibility likewise may enable the cleat base to flex as force is placed on the overall sole component, which may help the cleat to bend with the rubber or other material of the sole component rather than remaining stiff and unbent and pulling away from the material of the sole component.

[0024] The outer perimeter of the cleat base may surround a single cleat in at least some examples of this invention. If desired, at least 90% of an area of a bottom of the cleat located inside the outer perimeter of the cleat base may constitute a bottom surface of the cleat component and a bottom surface of the cleat base, and at least 95% of a combined surface area of the bottom surfaces of the cleat component and the cleat base may be planar, substantially planar, or smoothly curved. In some structures, at least 98% of this combined surface area may be planar, substantially planar, or smoothly curved.

[0025] In cleat structures in accordance with at least some examples of this invention, an exterior surface of the cleat base (i.e., the surface exposed to and in contact with the ground in use) may include one or more traction enhancing structures, such as fin cleats, nubs, pyramids, truncated pyramids, cylinders, and the like. These additional traction enhancing structures may be located between adjacent legs of the cleat component.

[0026] Cleat components in accordance with at least some examples of this invention may include ridges that extend between adjacent legs of the cleat components. The overall cleat then may be formed so that portions of the cleat base surround the ridges and/or extend through openings provided in the ridges to thereby engage the cleat bases with the cleat components. In such structures, the cleat may be formed by first forming the cleat components (e.g., by an injection molding process) and then forming the cleat base around the cleat component, e.g., in an in-molding process.

[0027] Additionally, if desired, cleat structures in accordance with at least some examples of this invention may include the various features described above in any desired combinations or subcombinations.

[0028] Still additional aspects of this invention relate to sole structures for articles of footwear (e.g., including midsole and/or outsole components) that have cleat structures of the types described above, as well as to articles of footwear (e.g., golf shoes) incorporating cleat structures and/or sole structures of the types described above.

[0029] B. Sole Structures According to Aspects of this Invention

[0030] Additional aspects of this invention relate to sole elements for articles of footwear. Such sole elements, which may constitute outsoles, midsoles, or midsole/outsole combinations, may include: (A) a cleat including an interior surface, an exterior surface opposite the interior surface, and an outer flange or rim, wherein the outer flange or rim includes a first surface, a second surface opposite the first surface, and an outer perimeter edge extending between the first and second surfaces, and wherein a plurality of perimeter openings extending through the outer flange or rim are located adjacent (and inside) the outer perimeter edge; and (B) a sole component engaged with the cleat, wherein the sole component includes a continuous layer of material that at least partially covers the outer perimeter edge, extends over at least some of the first and second surfaces of the outer flange or rim, and extends through at least some of the plurality of perimeter openings. If desired, the sole component may completely cover the interior surface of the cleat, and the material of the sole component may completely fill the plurality of perimeter openings. The cleat may include the structures described above and/or any combination or subcombination of the cleat features and/or structures described above. Also, while it may be removable from the sole component, in some more specific structures in accordance with examples of this invention, the cleat (or at least the cleat base) will be permanently fixed to the sole component (e.g., by an in-molding process, by cements or adhesives, by mechanical connectors, etc.).

[0031] If desired, an exterior surface of the sole component (i.e., the surface exposed to and in contact with the ground in use) may include one or more traction enhancing structures, such as fin cleats, nubs, pyramids, truncated pyramids, cylinders, removable cleats, and the like. The base area of the sole component, exclusive of a thickness of any traction elements formed therein, may have a maximum thickness of 7 mm or less, and in some examples, 6 mm or less, or even 5 mm or less. If desired, some sole elements in accordance with examples of this invention will have an overall maximum thickness through the cleat and the sole component (e.g., cleat plus outsole plus midsole thickness or height) of 15 mm or less, and in some examples, 13 mm or less, 10 mm or less, or even 7 mm or less.

[0032] Any desired number of cleats, e.g., of the types described above, may be engaged with a single sole component without departing from this invention. The cleats provided on a given sole component may have the same or different constructions and/or may be engaged with the sole component in the same or different manners.

[0033] Still additional aspects of this invention relate to sole structures for articles of footwear including one or more sole elements of the types described above (e.g., including midsole and/or outsole components), as well as to articles of footwear (e.g., golf shoes) incorporating cleat structures and/or sole elements of the types described above. If desired, the overall sole structure may include an outsole component (e.g., formed of a rubber or TPU material) with the cleat incorporated into it (e.g., by in-molding), and this outsole component may be engaged with a midsole component (e.g., including a polymeric foam material, one or more fluid-filled bladders, and/or one or more mechanical impact force attenuating components). The combined midsole/outsole structure then may be engaged with one or more upper and/or other footwear components (e.g., by sewing or stitching, by adhesives or cements, and/or by mechanical connectors, etc.).

[0034] C. Mold Structures According to Aspects of this Invention

[0035] Additional aspects of this invention relate to mold structures, e.g., for making molded products including in-molded components (e.g., for making a sole element for an article of footwear including an in-molded cleat). Some mold structures in accordance with aspects of this invention will include: (a) a first mold component (e.g., a first mold plate) including a first portion of a mold cavity and (b) a second mold component (e.g., a second mold plate) including a second portion of the mold cavity for at least partially covering the first portion of the mold cavity. The first portion of the mold cavity may include: (i) a first area for forming and/or shaping a first portion of an article to be molded (e.g., a footwear sole structure, such as an outsole component), wherein the first area includes a first molding surface exposed in the mold cavity made from a first material having a first thermal conductivity, and (ii) one or more additional areas (e.g., also called “second” and “third areas herein”) including a component receptacle for receiving a component to be in-molded into the article (e.g., for receiving a previously formed cleat element), wherein the component receptacle includes a second surface exposed in the mold cavity for engaging the component to be in-molded, and wherein the second surface is made from a second material having a second thermal conductivity that is less than the first thermal conductivity. If desired, a separate “second area” and/or component receptacle may be provided for each individual component (e.g., each individual cleat element) to be in-molded into the article. The individual “second areas” and/or component receptacles (when multiple areas and/or receptacles are present) may be completely separated from one another (e.g., such that the first molding surface forms a continuous path between the individual component receptacles and/or such that the first area of the mold cavity completely surrounds the individual component receptacle areas). The second mold component may completely cover the first portion of the mold cavity and/or completely cover one or more of the component receptacles.

[0036] As noted above, the first molding surface exposed in the mold cavity (for forming the first portion of an article

to be molded (e.g., a footwear sole structure, such as an outsole component)) is made from a first material having a first thermal conductivity and the second surface exposed in the mold cavity (for engaging the component to be in-molded) is made from a second material having a second thermal conductivity that is less than the first thermal conductivity. As some more specific examples, the first material may include a metal or metal alloy material (e.g., aluminum, steel, etc.) and the second material may include at least one material selected from the group consisting of: a ceramic material, a polymeric material, and a polymeric material including a ceramic, metal, or metal alloy powder dispersed therein. By having a lower thermal conductivity, the material of the second surface (e.g., the in-molded component receptacle surface) will heat up less quickly than the material of the first molding surface. This enables in-molding of a component that may not be satisfactorily in-molded at the temperatures, pressures, and/or timing conditions necessary for molding the article to be molded (i.e., components that might normally melt and/or otherwise deform under the necessary molding conditions).

[0037] As a more specific example, a previously formed cleat component may be engaged within a mold cavity at a cleat receptacle made from the second material described above. Because the surface of the cleat receptacle has a lower thermal conductivity than the material of the surrounding area (against which the outsole component is shaped and/or formed), the cleat receptacle does not heat up as quickly as the surrounding molding surface. Because the cleat receptacle heats up more slowly than the remainder of the molding surface, the cleat component may be placed in the mold cavity and engaged with an outsole component by an in-molding process under timing, temperature, and/or pressure conditions that could cause the cleat component to melt or deform if it was engaged directly with the material against which the outsole component is formed. In effect, in this example, the material of the cleat receptacle maintains the area of the mold in contact with the cleat component at a lower temperature during the outsole rubber molding cycle to prevent the cleat component from melting or otherwise deforming during the outsole rubber molding process.

[0038] Molds of the types described above may be used to form outsole components including in-molded cleats of any desired construction, including outsole components and/or in-molded cleats of the various types described above (and described in more detail below).

[0039] D. Molding Methods According to Aspects of this Invention

[0040] Still additional aspects of this invention relate to methods of forming molded articles (e.g., footwear sole structures), e.g., using the mold structures described above. Such methods may include placing a component to be in-molded (e.g., a cleat component) in a mold cavity, wherein the component to be in-molded includes an in-molding engagement area (e.g., a perimeter area, such as a flange or rim), and wherein the mold cavity includes: (i) a first area that includes a first molding surface exposed in the mold cavity made from a first material having a first thermal conductivity, and (ii) one or more additional areas including one or more in-molded component receptacles (e.g., a cleat receptacle), wherein the in-molded component receptacle includes a second surface exposed in the mold cavity for engaging the component to be in-molded, wherein the second surface is made from a second material having a

second thermal conductivity that is less than the first thermal conductivity, and wherein the component to be in-molded is engaged with the in-molded component receptacle. The method further may include introducing a moldable material into the mold cavity, wherein the moldable material flows around and/or through the in-molding engagement area of the component to be in-molded to engage the component to be in-molded with the moldable material. The mold may be held at temperature and/or pressure conditions for a sufficient time to enable the moldable material to flow to the desired areas to form the final article to be molded. Additional features of methods according to this aspect of the invention may include curing the moldable material after the step of introducing the moldable material into the mold cavity (inside or outside of the mold).

[0041] The moldable material may be introduced into the mold cavity in one or more steps. In some more specific examples, a first portion of the moldable material will be introduced into the mold cavity before the component to be in-molded is engaged with the component receptacle and then a second portion of the moldable material will be introduced into the mold cavity after the component to be in-molded is engaged with the component receptacle. In such methods, it may be necessary or desirable to clear the moldable material from the component receptacle area(s) before engaging the component to be in-molded with the receptacle area(s). Alternatively, if desired, the mold cavity may include an intermediate plate or other structure that prevents the moldable material from flowing over the component receptacle area(s) when the component(s) to be in-molded is (are) absent from the mold cavity.

[0042] When used to form outsole components with in-molded cleat elements of the types described above, molding methods according to aspects of this invention may further include engaging the outsole component (e.g., including a combined base footwear sole component and the in-molded cleat) with a midsole component, e.g., by cements or adhesives, by mechanical connectors, etc. The midsole component may have any desired structure without departing from this invention, including, for example, midsole components including a polymeric foam material, midsole components includes one or more fluid-filled bladders (optionally with the fluid-filled bladder(s) at least partially surrounded by a foam material), midsole components including one or more mechanical impact force attenuating structures, etc.

[0043] Sole structures of the types described above (including those made by the methods described above) may be incorporated into an article of footwear, e.g., to one or more upper components), in any desired manner, including in manners that are conventionally known and used in the footwear art.

[0044] Given the general description of features, aspects, structures, processes, and arrangements according to certain embodiments of the invention provided above, a more detailed description of specific example structures and methods in accordance with this invention follows.

II. DETAILED DESCRIPTION OF EXAMPLE STRUCTURES AND METHODS ACCORDING TO THIS INVENTION

[0045] Referring to the figures and following discussion, various articles of footwear, footwear components, and features thereof in accordance with the present invention are

described. The footwear depicted and discussed are golf shoes, but the concepts disclosed with respect to various aspects of this invention may be applied to a wide range of cleated or other athletic footwear styles, including, but not limited to: football shoes, hiking shoes, soccer shoes, baseball shoes, track shoes, and the like. Still additional concepts and aspects of this invention, such as the mold construction and molding method concepts and aspects of the invention, may be applied to production of other products, such as other products in which one or more permanently attached, in-molded components may be desired. Accordingly, the present invention is not limited to the precise embodiments disclosed herein, but it applies more generally to other types of footwear and/or other product lines.

[0046] FIGS. 1A and 1B show medial and lateral side views, respectively, of a golf shoe **100** in accordance with some aspects of this invention. FIG. 1C provides a bottom view of this example golf shoe **100**, and FIG. 1D provides an enlarged close-up view of one cleat element **150** provided on this example golf shoe **100**. The shoe **100** includes an upper **102** and a sole structure **104** engaged with the upper **102**. The upper **102** may be made from any desired material or combination of materials without departing from this invention, including from material(s) and/or construction(s) as are generally known and used in the footwear art. Some more specific examples of upper **102** materials include fabric or textiles, leathers (synthetic or natural), polymeric materials, spacer meshes, and the like. The upper **102**, at least in part, defines a foot-receiving opening **106** through which the wearer inserts a foot to don the shoe **100**. Laces **108** or other securing or foot engagement structures may be provided to securely hold the shoe **100** to a wearer's foot. In this illustrated example, the lace **108** engages a strap element **110** that wraps around the shoe **100** (including around and across the bottom of the sole structure **104**) to help conform the shoe to the wearer's foot as the lace **108** is tightened. Also, if desired, the strap element **110** can be removable (e.g., by unlacing the lace **108**) and replaced by another strap element **110**, e.g., to change colors, styles, and/or shapes of the strap element **110**, to otherwise change the appearance and/or feel of the strap element **110**, etc. A tongue member **112**, bootie, or other similar type structure may be provided at the shoe instep area, e.g., to increase comfort and/or to moderate the pressure and feel applied to the wearer's foot by the lace **108**.

[0047] The sole structure **104** may be engaged with the upper **102** in any desired manner, including in manners that are conventionally known and used in the footwear art (e.g., by sewing or stitching, by adhesives or cements, by mechanical connectors, etc.). In this illustrated example, the sole structure **104** includes a midsole component **104a** and an outsole component **104b** engaged with the midsole component **104a**. This engagement may be accomplished in any desired manner, including manners that are conventionally known or used in the footwear art (e.g., by cements or adhesives, by mechanical connectors, by sewing or stitching, etc.). In this illustrated example, the outsole component **104b** is formed by a molding process (which will be described in more detail below) separate from the midsole component **104a**, and the outsole component **104b** is formed in a shape to fit into shallow recesses formed in the surface of the midsole component **104a**. The two parts **104a**, **104b** are fixed to one another by cement in this example.

[0048] The midsole component **104a** may be made from any desired materials and/or in any desired manner without departing from this invention, including from conventional materials and in conventional manners as are known and used in the art. As some more specific examples, the midsole component **104a** may be formed from and/or include one or more of: a polymeric foam material (e.g., a polyurethane foam, an ethylvinylacetate foam, etc.); one or more fluid-filled bladders (e.g., optionally at least partially incorporated into a foam material and/or a plastic cage type structure); one or more polymeric foam columns (e.g., like the columns provided in NIKE SHOX™ type footwear); one or more mechanical impact force attenuating components; etc. In some examples, the midsole component **104a** may be at least partially made from a foam material having a density of less than 0.25 g/cm³ (and in some examples, a density of less than 0.2 g/cm³, within the range of 0.075 to 0.2 g/cm³, and even within the range of 0.1 to 0.18 g/cm³); a foam material as described, for example, in U.S. Pat. No. 7,941,938 (which patent is entirely incorporated herein by reference); and/or a foam material from the "LUNAR" family of footwear products available from NIKE, Inc. of Beaverton, Ore. The midsole component **104a** also may be formed from any desired number of independent pieces or parts without departing from this invention.

[0049] The outsole component **104b** of this example shoe structure **100** also may be made from any desired materials without departing from this invention, including from conventional materials as are known and used in the art. In accordance with at least some aspects of this invention, the outsole component **104b** may be made from a synthetic rubber material (e.g., a conventional outsole rubber material). The sole structure **104** of this example footwear structure **100** includes two separate outsole components **104b** engaged with a single polymeric foam midsole component **104a** by cement or adhesive. Outsole components **104b** and production systems and methods therefor in accordance with some aspects of this invention will be described in more detail below.

[0050] As shown in FIGS. 1A through 1D, each separate outsole component **104b** of this example footwear structure **100** includes a plurality of cleat elements **150** (or other traction enhancing components) engaged with it. While an individual outsole component **104b** may have any desired number of separate cleat elements **150** engaged with it (including zero), in this illustrated example, the forefoot outsole component **104b** has three cleat elements engaged with it (one on the medial side (inside) edge of the shoe **100** and two on the lateral side (outside) edge, with the center of the medial cleat **150** located between the centers of the two lateral cleats **150** in the front-to-back direction). Similarly, the heel outsole component **104b** has two cleat elements **150** engaged with it (one on the rear lateral side and one on the medial side and forward of the other). Other cleat numbers, arrangements, and orientations are possible without departing from this invention.

[0051] FIGS. 1A through 1D further illustrate that the outsole components **104b** of this example structure **100** include a plurality of secondary traction elements **152** integrally formed on the exterior (bottom) surface of the outsole component **104b**. While a plurality of raised nubs (e.g., cylinders or truncated pyramids) are shown in the figures, other traction element structures are possible without departing from this invention, such as raised fin type cleat struc-

tures, raised ribs, recessed grooves, etc. While provided primarily on the bottommost contact surface of the outsole component **104b**, if desired, at least some of these secondary traction elements **152** may be provided along a side area of the sole structure **104** (e.g., as shown in FIGS. **1A** and **1B**). These side oriented secondary traction elements **152** can be particularly useful, for example, as the user's weight shifts during the course of a golf swing, during a cutting or rapid direction change maneuver, etc.

[0052] More specific features and components of an example cleat structure **150** in accordance with at least some examples of this invention will be discussed below in conjunction with FIGS. **2A** through **2E**. This example cleat structure **150** includes a cleat component **154** (e.g., including traction enhancing element structures) and a cleat base **156**. The cleat component **154** may be engaged with the cleat base **156** in any desired manner, including through the use of cements or adhesives, via a friction fit, via detents or spring loaded type connections, etc. FIGS. **2A** and **2B** provide top and bottom views, respectively, of the cleat component **154**, and FIGS. **2C-2E** provide bottom, top, and cross sectional views of the overall cleat structure **150**.

[0053] The cleat component **154** and the cleat base **156** may be made from any desired materials without departing from this invention. In some specific example cleat constructions according to this invention, the cleat component **154** will be formed from a thermoplastic polyurethane material (TPU) and the cleat base **156** will be formed from a nylon **66** material. Other materials and/or combinations of materials also may be used without departing from this invention, including material combinations in which, in the finished cleat product, the cleat component **154** is made from a softer material than the cleat base **156**, although the cleat base **156** may remain at least somewhat flexible (particularly at its perimeter flange or rim area). As some more specific examples, the finished cleat component **154** may be made from a TPU material having a Shore A hardness ranging from 80 to 120 (and in some examples, in a range from about 90-100 Shore A, or even about 92-96 Shore A). In terms of Shore D hardness, the finished cleat component **154** of some example structures may be made from a TPU material having a Shore D hardness ranging from 36 to 52 Shore D (and in some examples, in a range from about 40-48 Shore D or even from about 42-46 Shore D). The finished cleat base **156** may be made from a nylon material having a Shore D hardness of about 70 to 88 Shore D, and in some examples, within the range of 75 to 85 Shore D or even 76 to 82 Shore D.

[0054] In some examples of this aspect of the invention, the cleat structure **150** may be made from the two parts noted above by an in-molding process. More specifically, first the cleat component **154**, e.g., as shown in FIGS. **2A** and **2B**, may be produced as a single part, for example, by an injection molding process. As shown in FIGS. **2A** and **2B**, this example cleat component **154** (which may be made from thermoplastic polyurethane material) may include a plurality of legs **158** that form some of the traction-enhancing elements of the cleat **150**. The cleat component **154** constitutes a single piece construction in which the legs **158** extend outward (toward the sides) from a common central area **160**. An anchor post **158a** extends from the bottom side of at least some of the legs **158** (toward an overall bottom surface of the cleat component **154**). While it is not required, preferably each leg **158** will include at least one anchor post

158a, and multiple anchor posts **158a** may be provided on at least some of the legs **158**, if desired. Any desired number of legs **158** (and/or any other desired types of traction enhancing structures) and/or anchor posts **158a** may be provided on the cleat component **154**.

[0055] As further shown in FIGS. **2A** and **2B**, this example cleat component **154** further includes ridges **162** that extend between adjacent legs **158**. While it is not required, preferably each adjacent pair of legs **158** will include at least one ridge **162**, and the ridge **162** may be continuous or discontinuous as it extends between the legs **158**. If desired, these ridges **162** may be formed to include one or more recesses, grooves, or openings **164**.

[0056] The anchor posts **158a**, ridges **162**, and/or openings **164** provide additional support and/or surface area for engaging the cleat base **156**, as will be described in more detail. As noted above, production of the cleat **150** may include an initial step of forming the cleat component **154**, e.g., by an injection molding process. One or more of the cleat components **154** thus formed then may be placed in another mold (or the mold in which they are formed may be modified), and the material of the cleat base **156** (e.g., nylon **66**) may be molded around the material of the cleat component **154**. In this additional molding step, the flowable material of the cleat base **156** may be injected into the mold so that material of the cleat base **156**: (a) flows around and surrounds at least the sides of the anchor post(s) **158a**, (b) extends around the upper surface, peripheral edge, and lower surface of the ridges **162**, and (c) extends into or through the recesses, grooves, or openings **164**. Once the material of the cleat base **156** is cured or hardened, it forms a continuous, one piece structure around the anchor post(s) **158a** and ridges **162** and through the openings **164** of the cleat component **154** (thus "in-molding" the cleat component **154** into a central opening left in the cleat base **156**). This continuous in-molded construction helps prevent undesired separation of the cleat component **154** from the cleat base **156** irrespective of the relative forces applied between these components (e.g., tensile, pulling force, torsional force, etc.). In this illustrated structure, as shown in FIGS. **2C-2E**, the outer perimeter **156P** of the cleat base **156** forms an outermost perimeter of the overall cleat structure **150**.

[0057] Additional features of this example cleat structure **150** now will be described. As shown in FIGS. **2C-2E**, the cleat base **156** of this example structure **150** is formed (e.g., during the in-molding procedure mentioned above) to include a set of perimeter openings **156O** or grooves located adjacent and inside the outer perimeter **156P** of the cleat base **156**. These openings **156O**, which may vary widely in numbering, positioning, shape, etc., provide support and surface area for engaging the cleat **150** with a footwear sole structure **104**, as will be described in more detail below. In addition, the bottom or interior surface of the cleat base **156** may be formed to include one or more raised elements **156N** (e.g., 0.5 to 4 mm high ridges, nubs, etc., see FIG. **2C**), which also can provide additional anchoring support for the cleat **150** to sole structure **104** engagement described in more detail below. The numbers, locations, shapes, orientations, and/or relative positioning of the openings or grooves **156O** and/or raised elements **156N** may be varied widely without departing from this invention.

[0058] In the cleat structure **150** illustrated in FIGS. **2C-2E**, an entire bottom of the cleat **150** is located inside the outer perimeter **156P** of the cleat base **156**, and this perim-

eter 156P surrounds a single cleat structure 150. In at least some structures in accordance with examples of this invention, at least 90% (and in some examples, at least 95%) of an area of the bottom of the cleat comprises: (a) a bottom surface of the cleat component 154, a bottom surface of the cleat base 156, and the set of perimeter openings 156O (see FIG. 2C). In such structures, at least 90% of a combined surface area of the bottom surfaces of the cleat component 154 and the cleat base 156 (excluding the missing surface at openings 156O) is planar, substantially planar, or smoothly curved, and in some examples, at least 95% or even at least 98% of this combined surface area is planar, substantially planar, or smoothly curved. As a more specific example, as shown in FIG. 2C, the area corresponding to the raised nubs 156N from the bottom surface of cleat base 156 may constitute less than 5% (and in some examples, less than 2%) of the combined bottom surface area of cleat base 156 and cleat component 154, and the bottom surfaces of the cleat base 156 and the cleat component 154 are planar, substantially planar, or smoothly curved over their own surfaces and with respect to one another. Notably, as evident from FIGS. 2C and 2E, the bottom of this cleat structure 150 does not include a threaded base member or a turnbuckle type releasable attachment structure.

[0059] FIGS. 2A through 2E illustrate additional features that may be included in cleat structures 150 in accordance with at least some examples of this invention. As shown in FIGS. 2A and 2B, the cleat component 154 may be formed to include a central opening 166 (e.g., through the common central area 160). During the in-molding process for forming the cleat 150, the flowable material of the cleat base 156 may be injected into the mold so that a portion of the cleat base 156 material extends to and is exposed to an outer surface of the cleat 150 through the central opening 166. Thus, in this central area 160, the portion of the cleat base 156 material exposed at the outer surface of the cleat structure 150 through the central opening 166 is surrounded by the material of the cleat component 154. This feature also can help anchor the cleat component 154 with the cleat base 156.

[0060] The portion of the cleat base 156 material exposed at the outer surface of the cleat structure 150 through the central opening 166 may have any desired color, shape, and/or orientation without departing from this invention. For example, if desired, the exposed cleat base 156 material at the central opening 166 may be a different color from the surrounding cleat component 154 material and may take on the shape of a logo, design, or word. Also, if desired, the central area 160 of the cleat component 154 may have plural openings 166 of this type.

[0061] As additional potential features, if desired, the exterior or exposed surface of the cleat base 156 may include one or more traction enhancing structures. In this illustrated example, the exterior surface of the cleat base 156 includes traction enhancing structures located between each adjacent pair of legs 158 of the cleat component 154 (although more traction enhancing structures may be provided, if desired). While any desired traction enhancing structure may be used without departing from this invention, in the illustrated example structure 156 shown in FIG. 2D, the exterior surface of the cleat base 156 includes fin cleat elements 168 located between each pair of adjacent legs 158 of the cleat component 154. These fin elements 168 are integrally formed in the material of the cleat base 156 during the

molding process at the areas thereof that overlie the ridges 162 and openings 164 of the cleat component 154.

[0062] As mentioned above, cleat structures 150, e.g., of the types described above, may be incorporated into a sole structure 104 of an article of footwear 100, such as engaged with an outsole component 104b of the article of footwear 100. While this engagement may take on a variety of forms, in one example of this invention, one or more cleat structures 150 (e.g., of the types described above) are permanently engaged with an outsole component 104b by an in-molding process. With the more specific cleat construction 150 of the type described above, however (with a nylon cleat base 156 and a TPU cleat component 154 engaged with it), portions of the cleat 150 may be subject to deformation (e.g., melting, disfiguration, etc.) when processed under molding conditions (e.g., time, temperature, and/or pressure) needed to shape the material (e.g., synthetic rubber) of the outsole component 104b. Accordingly, additional aspects of this invention relate to mold structures and molding methods that allow in-mold attachment of cleats 150 with an outsole component 104b, as will be described in more detail below.

[0063] FIGS. 3A and 3B illustrate various features of a mold 300 according to at least some examples of this invention, e.g., for forming a sole element of an article of footwear, such as an outsole component (e.g., like component 104b with cleat element 150 in-molded therewith). The mold 300 includes a first mold component 302 (e.g., a mold plate) including a first portion of one or more mold cavities 304 in which the outsole component is formed. As shown in FIG. 3A, a single mold component 302 may include a plurality of different mold cavities 304, which may be interconnected or completely separated from one another. The first portion(s) of the mold cavity 304 in this example mold structure 300 include a first area for forming a base footwear sole component (e.g., outsole element 104b). As shown in FIG. 3A, the first area includes a first molding surface 304A exposed in the mold cavity 304 made from a first material having a first thermal conductivity. In the illustrated example, the first molding surface 304A is made from a metal or metal alloy material, such as aluminum or aluminum alloys, iron or iron alloys, steels, etc. In this illustrated example, the first molding surface 304A includes indentations for integrally forming the raised nub structures 152 described above.

[0064] This same mold cavity 304 includes one or more cleat receptacles 304B (ten total cleat receptacles 304B are shown in the four separate mold cavities 304 of the mold 300 illustrated in FIG. 3A). The cleat receptacle 304B constitutes a second surface exposed in the mold cavity 304 for engaging a previously formed cleat 150 (or other component to be in-molded into the base structure). The cleat receptacle 304B of this illustrated example includes a surface made from a second material having a second thermal conductivity that is less than the first thermal conductivity of the material of the molding surface 304A. In other words, the cleat receptacle surface 304B is made from a material that does not heat up as quickly as the material making up the molding surface 304A. As some more specific examples, the cleat receptacle 304B (at least its surface exposed in the mold cavity 304) may be made from one or more of: a ceramic material (e.g., silica, alumina, zirconia, carbides, borides, nitrides, silicides, etc.), a polymeric material (e.g., a low thermal conductive polymer), and a polymeric material including a ceramic, fiber, metal, or metal alloy powder dispersed

therein. As some more specific examples, the cleat receptacle surface **304B** may be made using an organic binder material that may contain, for example, one or more of: (a) a mixture of an epoxy (e.g., 10-15% by weight in component (a)), an amino resin compound (e.g., 10-15% by weight in component (a)), and a filling agent (e.g., a thickener in an amount of 70-75% by weight in component (a)) and (b) a hardening agent. If desired, components (a) and (b) above may be present in amounts of about 1:1 in the organic binder.

[0065] The cleat receptacles **304B** of FIGS. **3A** and **3B** constitute “negatives” of at least some portions of the top surface of cleat component **154** and cleat base **156** shown in FIGS. **2A-2E** so that the cleat structures **150** will securely fit in the cleat receptacles **304B** while the outer perimeter flange or rim (e.g., a disk or washer-like rim or edge) of the cleat structure **150** extends beyond the edges of the cleat receptacle **304B**. In this illustrated example, the cleat receptacles **304B** include recessed surfaces **358** for engaging and holding the legs **158** of cleat component **154** and recessed surfaces **368** for engaging and holding the fin cleats **168** of cleat base **156**. The recessed surfaces **358** and **368** prevent rapid heat up of cleat component **154** and cleat base **158** during the outsole molding process (because of their lower thermal conductivity) and help prevent movement of the cleat structure **150** during the outsole molding process (e.g., when flowable outsole material is injected into the mold **300**).

[0066] When multiple cleat receptacles **304B** are present in a single mold cavity **304**, the materials of the cleat receptacles **304B** may be completely separated from one another, e.g., the material of the first molding surface **304A** may form a continuous path between the separated cleat receptacles **304B** within a given mold cavity **304**. In such structures, the material of the molding surface **304A** may completely surround each individual cleat receptacle **304B**. Alternatively, if desired, a single cleat receptacle area **304B** may be sized and shaped so as to engage two or more cleat structures **150**.

[0067] The mold **300** further may include a second mold component including a second portion of the mold cavity (e.g., a plate with a flat or shaped interior surface) for at least partially (and optionally completely) covering the first portion of the mold cavity **304**. While the second mold component is not shown in the figures, FIG. **3A** illustrates hinge components **306** at which the second mold component may engage the first mold component **302** in a rotatable manner. If necessary, one or more intermediate plates may be provided between the mold component **302** and the second mold component, at least at some times during a molding procedure. Alignment aids **308** help assure proper orientation and positioning of the mold components with respect to one another as the mold **300** is closed during a molding process. The second mold component may constitute a single plate, e.g., that completely covers all of the mold cavities **304** and completely covers all of the cleat receptacle (s) **304B**. Optionally, if desired, the interior surface of the second mold component (or an intermediate plate) may include areas having a lower thermal conductivity (the same as or similar to the material of receptacles **304B**), e.g., at areas covering or adjacent the cleat receptacles **304B**.

[0068] One example of a molding procedure for attaching a component to be in-molded (e.g., a cleat element **150**) with another article (e.g., an outsole component) is described below in conjunction with FIGS. **3A-3G**. First, starting with

the mold structure **300** shown in FIG. **3A**, the mold **300** is closed (i.e., the mold components are brought together by relative rotation on the hinges **306**). One or more intermediate plates may be provided between (and optionally engaged with one or both of) the mold component **302** and the second mold component. A first shot of outsole material (e.g., synthetic rubber) then may be injected into the enclosed mold cavities **304** to create a layer of outsole material **310** within the mold cavities **304** as shown in FIG. **3C**. In this example process, the layer of outsole material **310** completely covers the cleat receptacles **304B**, although an interior surface of the intermediate plate and/or the second mold component (i.e., the surface located within the mold cavity **304** when the mold **300** is closed) may be shaped so as to prevent the outsole material **310** from covering the cleat receptacles **304B**, if desired.

[0069] In the next step, as shown in FIG. **3D**, the outsole material **310** is cleared off the areas above the cleat receptacles **304B** to thereby expose the cleat receptacles **304B** within the mold cavities **304**. This may be accomplished by cutting the outsole material **310** around each receptacle **304B**, e.g., using a knife or blade. Then, as shown in FIG. **3E**, previously formed cleat elements **150** (e.g., as shown in FIGS. **2C-2E**) are fit into the cleat receptacles **304B** so that the bottom or interior sides of the cleat elements **150** face the interior of the mold cavities **304**. The outer perimeter or rim of the cleat base **156** (including the openings **156O** not shown in FIG. **3E**) may extend outward beyond the edges of the cleat receptacles **304B**. Also, while the downward oriented surface of the outer perimeter or rim of the cleat base **156** may lie flush with (or even press into) the surface of the already present outsole material **310** in the mold cavities **304**, in some examples of this aspect of the invention, the downward oriented surface of the outer perimeter or rim of the cleat base **156** may be somewhat elevated with respect to the surface of the already present outsole material **310** in the mold cavities **304** (i.e., the cleats **150** may be fully supported by the cleat receptacles **304B** such that the cleat base **156** outer rim is suspended above the outsole material **310** in the bottom of the mold cavities **304**).

[0070] The mold **300** is then closed again and additional flowable outsole material **310** (the same or different from that previously introduced) is again introduced into the mold cavities **304**. If desired, as shown in FIG. **3F**, sufficient moldable outsole material **310** may be introduced to completely cover the interior surfaces of the cleat elements **150**. This action further causes the flowable outsole material **310** to cover and/or surround the outer perimeter or rim of the cleat bases **156** and to flow through the openings **156O** through the rim to thereby permanently engage the cleats **150** with the outsole material **310**. Note, for example, area **312** in FIG. **3H** (a partial cut-away view of a portion of an outsole component **104b**), which shows the outsole material **310** extending around the perimeter or rim of the cleat base **156** and through the openings **156O**. The flowable outsole material **310** introduced during this step may blend with and form a continuous layer of material with the outsole material **310** introduced earlier (e.g., during the step of FIG. **3C**). In this manner, a single, continuous layer of outsole material **310** completely covers and extends through the perimeter openings **156O** of the cleat base **156**. The outsole material **310** extending through the openings **156O** and the surrounding/embedding of the raised areas **156N** of the cleat base **156**

into the outsole material **310** attach the cleat **150** to the outsole material **310** in an “in-molded” manner.

[0071] The outsole material **310** then may be finally cured and/or otherwise treated, and the combined outsole member **104b** (including the outsole material **310** and the in-molded cleat components **150**) may be removed from the mold **300** (e.g., as shown by FIG. 3G (for improved clarity, the optional traction enhancing nubs **152** are not shown in FIG. 3G)). The curing or other post-molding treatments may be performed while the combined outsole member **104b** is located within the mold **300** and/or after it is removed from the mold **300**. The combined outsole member **104b** further may be engaged with a midsole component **104a** and/or otherwise engaged with an upper **102** or other structure to form an article of footwear (e.g., golf shoe **100**).

[0072] The material of the cleat receptacles **304B** helps prevent the materials of the cleat structures **150** (e.g., the cleat component **154** and/or the cleat base **156**) from melting and/or otherwise deforming under the timing, heat, and/or pressure conditions used for molding the outsole material **310** into the desired configuration. As noted above, the materials at the surface of the cleat receptacles **304B** have a lower thermal conductivity, and thus heat up less rapidly, than the material of the molding surfaces **304A** of the mold cavities **304**. This slowing of the heat transfer at the cleat receptacle areas **304B** helps keep the cleat structures **150** sufficiently cool during the molding process (and optionally also during any curing and/or post-molding processes) to prevent melting and/or deformation of the cleat structure **150**.

[0073] As one more specific example, the TPU material of the example cleat component **154** mentioned above may have a melting point of about 170° C., but under the temperature and pressure conditions used during formation of the base outsole component **104b** (e.g., about 150° C. and elevated pressure), this TPU may begin to deform or melt at temperatures as low as about 90° C. The cleat receptacles **304B** help keep the temperature around the cleats **150** somewhat lower during the outsole molding process (because the receptacle surfaces **304B** heat up more slowly) to decrease the likelihood of the TPU melting or deforming during the molding process.

[0074] Many variations may be made from the specific molding processes described above without departing from this invention. For example, if desired, the cleat structures **150** could be set in the cleat receptacles **304B** before any moldable outsole material **310** is introduced into the mold cavity **304**, and/or the moldable outsole material **310** may be introduced in a single, molding step. This option, however, may require the use of some type of support within the mold cavity **304** (e.g., retractable pins) to hold the cleat structures **150** in the proper position while the moldable material **310** is being introduced (e.g., so that the flowing moldable material **310** does not tilt, knock askew, or otherwise affect positioning of the cleat structures **150**). Such support structures also may be used in the processes of FIGS. 3A-3F, if necessary or desired.

[0075] Additionally, while the discussion of the mold structures and molding methods above relate primarily to production of cleated sole structures, features of these aspects of the invention may be applied to in-molding components other than cleats and/or footwear outsole components. Rather, aspects of this invention may be applied to molding any types of articles with in-molded components,

and particularly to molding articles in which the base component to be molded must be processed under temperature, pressure, and/or timing conditions that could result in melting, deformation, and/or other types of damage to the in-molded component(s).

[0076] FIGS. 4A-4D illustrate further advantages potentially available in cleats and cleated sole structures in accordance with at least some examples of this invention. FIGS. 4A and 4B illustrate a partial cut-away perspective view and a cross sectional view, respectively, of an existing removable golf cleat element **402** engaged with a golf shoe sole structure (including a midsole element **404a** and an outsole element **404b**), while FIGS. 4C and 4D show similar views of a golf cleat element **150** in-molded with an outsole component **104b** in accordance with at least some examples of this invention. As evident from these figures, an interior side of the known removable cleat element **402** includes a turnbuckle type connection system **402a** for releasably connecting the cleat element **402** with corresponding connection structures **402b** provided in (e.g., engaged with) the outsole element **404b**. In addition to the added expense and manufacturing issues involved in incorporating these additional connection structures into a golf shoe, the turnbuckle connection system **402a** of the cleat **402** and the connection structures **402b** of the outsole **404b** project upward toward the wearer's foot. As shown in FIG. 4B, the height H_1 of the outsole component **404b** from the bottom surface **406B** to the top surface **406T** at and around the cleat engagement area is relatively high (e.g., typically at least about 8 mm) to accommodate the additional turnbuckle engagement structures **402a**, **402b** needed in the outsole **404b**.

[0077] These turnbuckle connection system structures **402a**, **402b** also are relatively hard and stiff in order to prevent deformation and to assure a reliable connection between the cleat **402** and the sole structure **404b**. Therefore, the turnbuckle connection system structures **402a**, **402b** may apply significant pressure points and discomfort to the wearer's foot (particularly in view of the distances walked while playing a round of golf). Footwear manufacturers attempt to moderate the feel of these types of cleats either by adding significant midsole foam **404a** (or other material) over the cleat areas or by covering the cleat areas with a rigid moderator plate (in an effort to disperse the load over a larger area of the foot). These features increase the overall height of the sole structure and/or reduce flexibility and/or natural feel of the shoe.

[0078] The cleat and sole structures in accordance with at least some examples of this invention, on the other hand, as shown in FIGS. 4C and 4D, avoid some of these issues with the known cleats. As described above, by using the in-molded connection/attachment features, the overall bottom or interior surface of cleats **150** in accordance with at least some examples of this invention are planar, substantially planar, and/or smoothly contoured. Additionally, the cleats **150** (and particularly the outer perimeter or rim area of the cleat base **156**) may be made from materials that allow the cleat bottom surface to flex under an applied load (e.g., to better conform to the applied load shape). These features help avoid or reduce application of point load forces to the bottom plantar surface of the wearer's foot and help avoid or reduce the need for moderator plates and/or quite thick midsole material and midsole height to moderate the feel of the cleat **150**. This flexibility likewise may enable the cleat base to flex as force is placed on the overall sole component,

which may help the cleat to bend with the rubber or other material of the sole component rather than remaining stiff and unbent and pulling away from the material of the sole component (thereby tearing or breaking the rubber or other material holding the sole to the cleat). Sole structures in accordance with at least some examples of this invention also may have a reduced weight due to the reduced amount (s) of outsole and/or midsole material.

[0079] Additionally, the in-molded attachment features of cleats **150** in accordance with at least some examples of this invention avoid the need for turnbuckle, threaded, or other releasable cleat attachment features. This also helps avoid the point load features described above. Also, as illustrated in FIG. 4D, this feature allows the overall height H_2 of the outsole component **104b** from the bottom surface **408B** to the top surface **408T** at and around the cleat engagement area to be made lower. The base outsole component thickness H_2 at and around the cleat engagement area may be made to be less than 7 mm (exclusive of the height of any raised nubs or other traction elements integrally formed in the outsole), and in some examples, less than 5 mm. In the illustrated example structure of FIG. 4D, the base outsole component thickness H_2 (exclusive of the height of any raised nubs or other traction elements integrally formed in the outsole) is about 4 mm. Therefore, the overall sole structure **104** of articles of footwear according to at least some examples and aspects of this invention may be made with a smaller overall height, a lower profile, and a more flexible construction. Aspects of sole structures in accordance with at least some examples of this invention may allow production of a more natural motion golf shoe (or other cleated shoe) construction.

[0080] As some additional potential advantages, the in-molding procedures for making the cleat structure **150** and/or the outsole component **104b** may avoid the need to use primers, cements, or adhesives (or other chemicals, e.g., to engage the cleat component **154** with the cleat base **156** and/or to engage the cleat **150** with the base outsole material **104b**). Thus, easier, cost-effective, and more environmentally friendly production processes may be used (as compared with processes that use of primers, adhesives, and/or cements). Alternatively, if desired, the in-molding processes described above could be used along with use of at least some amount of primers, adhesive, or cements (optionally, however, a reduced amount as compared to conventional processes, e.g., to better hold the parts in place at least during the initial phases of the production processes).

III. CONCLUSION

[0081] The present invention is disclosed above and in the accompanying drawings with reference to a variety of embodiments. The purpose served by the disclosure, however, is to provide examples of the various features and concepts related to the invention, not to limit the scope of the invention. Those skilled in the art will understand that the structures, options, and/or alternatives for the cleat structures, sole structures, footwear structures, molds, and/or molding methods described herein, including the features of the various different embodiments of the invention, may be used in any desired combinations, subcombinations, and the like, without departing from the invention. Those skilled in the relevant art also will recognize that numerous variations and modifications may be made to the embodiments

described above without departing from the scope of the present invention, as defined by the appended claims.

1. An outsole element for an article of footwear, comprising:

a cleat including an interior surface, an exterior surface opposite the interior surface, and an outer flange, wherein the outer flange includes a first surface, a second surface opposite the first surface, and an outer perimeter edge extending between the first and second surfaces, wherein a plurality of perimeter openings extending through the outer flange are located adjacent the outer perimeter edge, and wherein at least 95% of the interior surface of the cleat is planar, substantially planar, or smoothly curved; and

an outsole component engaged with the cleat, wherein the outsole component includes a continuous layer of outsole material that covers the outer perimeter edge, extends over the first and second surfaces of the outer flange, and through the plurality of perimeter openings, and wherein the outsole component completely covers the interior surface of the cleat and completely covers the plurality of perimeter openings.

2. The outsole element according to claim **1**, wherein at least 95% of an interior surface of the outsole component is planar, substantially planar, or smoothly curved.

3-9. (canceled)

10. The outsole element according to claim **1**, further comprising:

a second cleat including a second interior surface, a second exterior surface opposite the second interior surface, and a second outer flange, wherein the second outer flange includes a third surface, a fourth surface opposite the third surface, and a second outer perimeter edge extending between the third and fourth surfaces, wherein a second plurality of perimeter openings extending through the second outer flange are located adjacent the second outer perimeter edge, wherein at least 95% of the second interior surface of the second cleat is planar, substantially planar, or smoothly curved, wherein the continuous layer of the outsole material of the outsole component additionally covers the second outer perimeter edge, extends over the third and fourth surfaces of the second outer flange, and extends through the second plurality of perimeter openings, and wherein the outsole component completely covers the second interior surface of the second cleat and completely covers the second plurality of perimeter openings.

11. The outsole element according to claim **10**, wherein at least 95% of an interior surface of the outsole component is planar, substantially planar, or smoothly curved.

12-17. (canceled)

18. The outsole element according to claim **1**, further comprising:

a second cleat including a second interior surface, a second exterior surface opposite the second interior surface, and a second outer flange, wherein the second outer flange includes a third surface, a fourth surface opposite the third surface, and a second outer perimeter edge extending between the third and fourth surfaces, wherein a second plurality of perimeter openings extending through the second outer flange are located adjacent the second outer perimeter edge, and wherein

at least 95% of the second interior surface of the second cleat is planar, substantially planar, or smoothly curved; and

- a third cleat including a third interior surface, a third exterior surface opposite the third interior surface, and a third outer flange, wherein the third outer flange includes a fifth surface, a sixth surface opposite the fifth surface, and a third outer perimeter edge extending between the fifth and sixth surfaces, wherein a third plurality of perimeter openings extending through the third outer flange are located adjacent the third outer perimeter edge, wherein at least 95% of the third interior surface of the third cleat is planar, substantially planar, or smoothly curved, and wherein the continuous layer of outsole material of the outsole component additionally covers the second and third outer perimeter edges, extends over the third, fourth, fifth, and sixth surfaces, and extends through the second and third plurality of perimeter openings.

19. An article of footwear, comprising:

an upper; and

a sole structure engaged with the upper, wherein the sole structure includes an outsole element having:

- a cleat including an interior surface, an exterior surface opposite the interior surface, and an outer flange, wherein the outer flange includes a first surface, a second surface opposite the first surface, and an outer perimeter edge extending between the first and second surfaces, wherein a plurality of perimeter openings extending through the outer flange are located adjacent the outer perimeter edge and wherein at least 95% of the interior surface of the cleat is planar, substantially planar, or smoothly curved; and

an outsole component engaged with the cleat, wherein the outsole component includes a continuous layer of outsole material that covers the outer perimeter edge, extends over the first and second surfaces of the outer flange, and through the plurality of perimeter openings.

20. The article of footwear according to claim **19**, wherein the article of footwear is a golf shoe.

21. The article of footwear according to claim **19**, wherein the outsole material completely covers the interior surface of the cleat and completely covers the plurality of perimeter openings.

22. The article of footwear according to claim **19**, wherein the sole structure further includes a midsole component, wherein the outsole component is engaged with the midsole component, and wherein the continuous layer of outsole material separates the cleat from the midsole component.

23. The article of footwear according to claim **19**, wherein the sole structure further includes a midsole component, wherein a surface of the midsole component includes a recess, and wherein the outsole component is shaped to fit into and is fixed in the recess of the midsole component.

24. The article of footwear according to claim **19**, wherein the outsole element further includes a second cleat including a second interior surface, a second exterior surface opposite the second interior surface, and a second outer flange, wherein the second outer flange includes a third surface, a fourth surface opposite the third surface, and a second outer perimeter edge extending between the third and fourth surfaces, wherein a second plurality of perimeter openings

extending through the second outer flange are located adjacent the second outer perimeter edge, wherein at least 95% of the second interior surface of the second cleat is planar, substantially planar, or smoothly curved, and wherein the continuous layer of the outsole material of the outsole component additionally covers the second outer perimeter edge, extends over the third and fourth surfaces of the second outer flange, and extends through the second plurality of perimeter openings.

25. The article of footwear according to claim **19**, wherein the sole structure further includes a second outsole element separate from the outsole element, the second outsole element having:

- a second cleat including a second interior surface, a second exterior surface opposite the second interior surface, and a second outer flange, wherein the second outer flange includes a third surface, a fourth surface opposite the third surface, and a second outer perimeter edge extending between the third and fourth surfaces, wherein a second plurality of perimeter openings extending through the second outer flange are located adjacent the second outer perimeter edge, and wherein at least 95% of the second interior surface of the second cleat is planar, substantially planar, or smoothly curved; and

- a second outsole component separate from the outsole component and engaged with the second cleat, wherein the second outsole component includes a second continuous layer of outsole material that covers the second outer perimeter edge, extends over the third and fourth surfaces of the second outer flange, and through the second plurality of perimeter openings.

26. The article of footwear according to claim **25**, wherein the outsole material of the continuous layer of the outsole component completely covers the interior surface of the cleat and completely covers the plurality of perimeter openings, and wherein the outsole material of the second continuous layer of the second outsole component completely covers the second interior surface of the second cleat and completely covers the second plurality of perimeter openings.

27. The article of footwear according to claim **25**, wherein the sole structure further includes a midsole component, wherein the outsole component is engaged with the midsole component, wherein the continuous layer of outsole material of the outsole component separates the cleat from the midsole component, wherein the second outsole component is engaged with the midsole component, and wherein the second continuous layer of outsole material of the second outsole component separates the second cleat from the midsole component.

28. The article of footwear according to claim **27**, wherein a bottom surface of the midsole component is exposed at an exterior of the article of footwear between the outsole component and the second outsole component.

29. The article of footwear according to claim **19**, further comprising:

- a strap element extending from a first side of an instep opening of the upper, around a bottom of the sole structure, and to a second side of the instep opening.

30. The article of footwear according to claim **29**, further comprising:

a lace that engages the strap element at the first side of the instep opening and at the second side of the instep opening.

31. The article of footwear according to claim **29**, wherein the strap element is removably engaged with the sole structure.

32. A sole structure for an article of footwear, comprising: a midsole component; and

an outsole element engaged with the midsole component, the outsole element including:

a cleat including an interior surface, an exterior surface opposite the interior surface, and an outer flange, wherein the outer flange includes a first surface, a second surface opposite the first surface, and an outer perimeter edge extending between the first and second surfaces, wherein a plurality of perimeter openings extending through the outer flange are

located adjacent the outer perimeter edge, and wherein at least 95% of the interior surface of the cleat is planar, substantially planar, or smoothly curved; and

an outsole component engaged with the cleat, wherein the outsole component includes a continuous layer of outsole material that covers the outer perimeter edge, extends over the first and second surfaces of the outer flange, and through the plurality of perimeter openings, and wherein the continuous layer of outsole material separates the interior surface of the cleat from the midsole component.

33. The sole structure according to claim **32**, wherein at least 95% of an interior surface of the outsole component is planar, substantially planar, or smoothly curved.

* * * * *