



US 20150225950A1

(19) **United States**

(12) **Patent Application Publication**  
**RAPAZ**

(10) **Pub. No.: US 2015/0225950 A1**

(43) **Pub. Date: Aug. 13, 2015**

(54) **CONSTRUCTION PANEL**

(52) **U.S. Cl.**

(71) Applicant: **Antonio RAPAZ**, Chilliwack (CA)

CPC ..... **E04C 2/365** (2013.01); **E04C 2002/005** (2013.01)

(72) Inventor: **Antonio RAPAZ**, Chilliwack (CA)

(21) Appl. No.: **14/691,040**

(57) **ABSTRACT**

(22) Filed: **Apr. 20, 2015**

**Related U.S. Application Data**

(63) Continuation of application No. 13/919,906, filed on Jun. 17, 2013, now Pat. No. 9,010,060, which is a continuation-in-part of application No. 11/874,388, filed on Oct. 18, 2007, now Pat. No. 8,464,490, which is a continuation-in-part of application No. 11/746,301, filed on May 9, 2007, now abandoned.

**Publication Classification**

(51) **Int. Cl.**  
**E04C 2/36** (2006.01)

This application relates to a light-weight, multi-purpose construction panel. The panel may be formed, for example, from molded plastic. Each panel includes a substantially planar deck on a first side thereof and a second side comprising alternating male and female sleeves arranged in honeycomb-like compartments defined by a plurality of wall elements. A pair of panels may be releasably coupled together with their respective second sides facing inwardly to form a construction assembly. When a pair of panels is coupled together, the male sleeves of one panel matingly fit within the female sleeves of the other panel, and vice versa. The panel assemblies may be used for many different construction applications including flooring, roofing and wall structures.

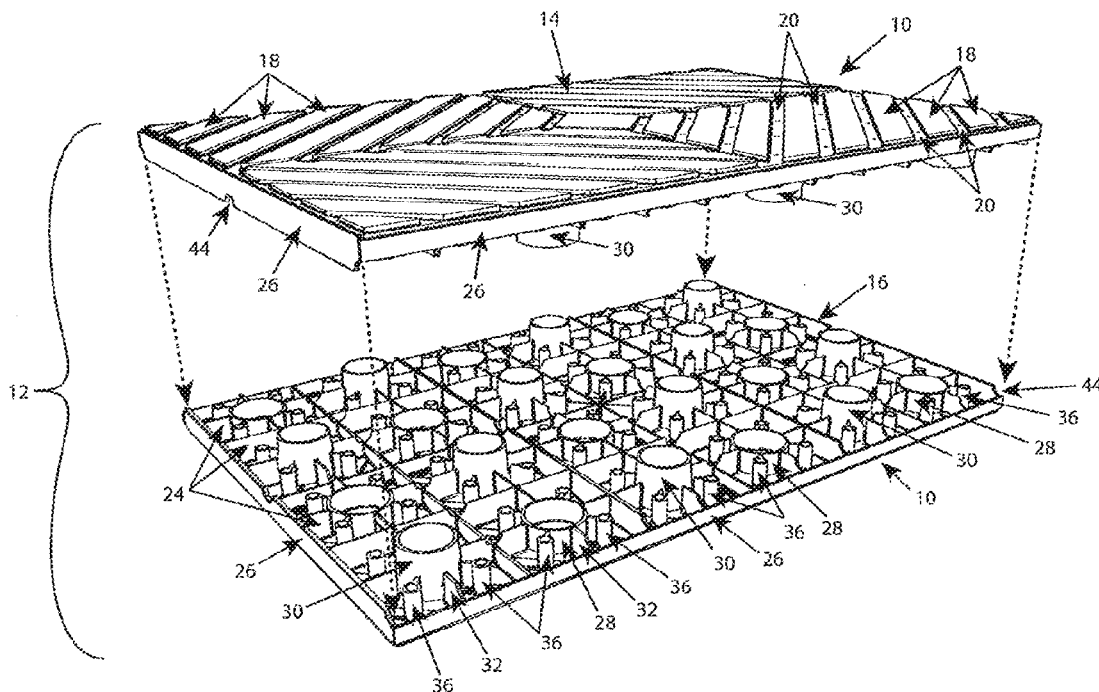

FIGURE 1

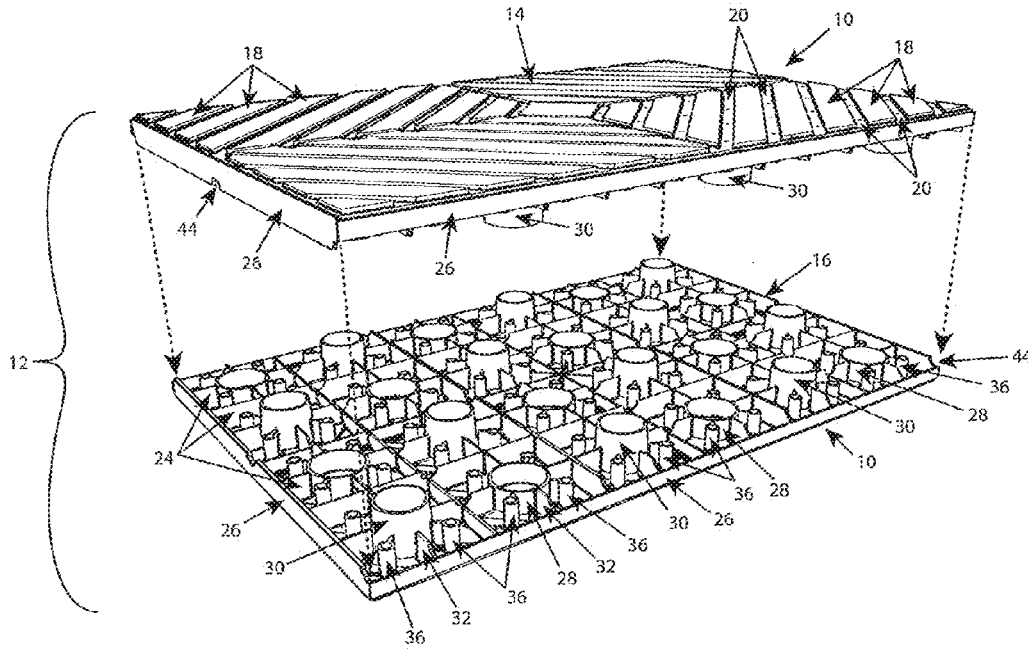
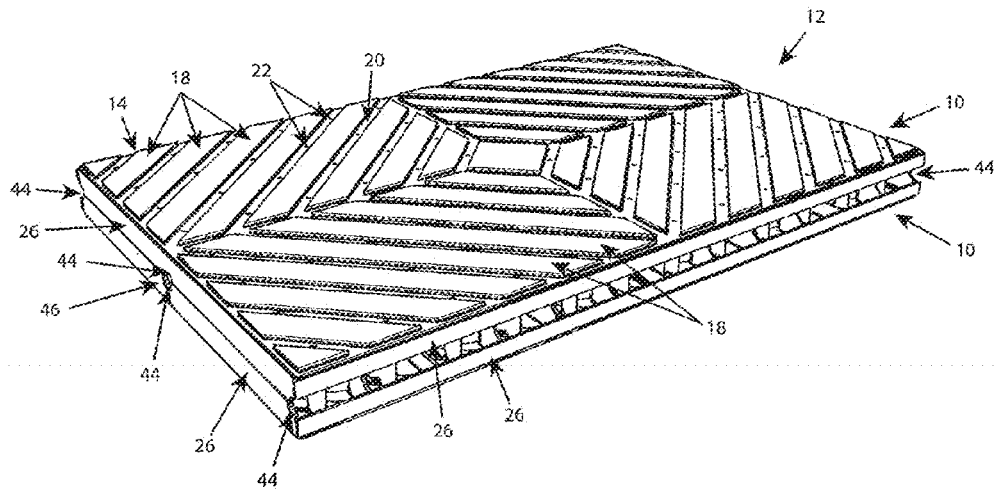
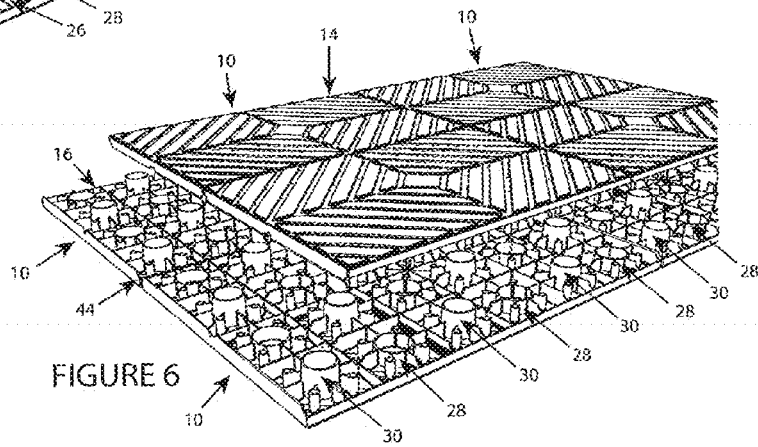
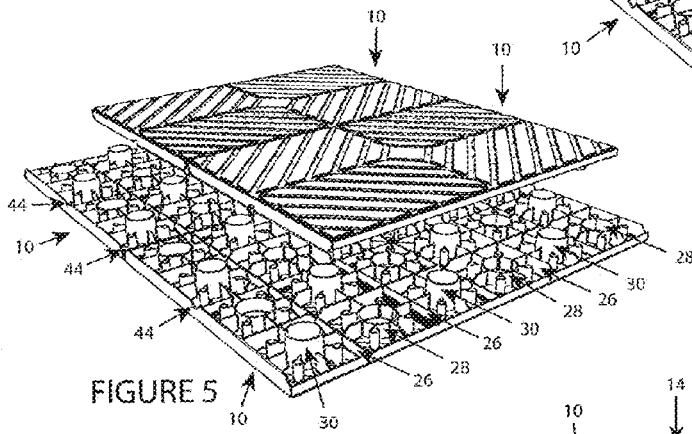
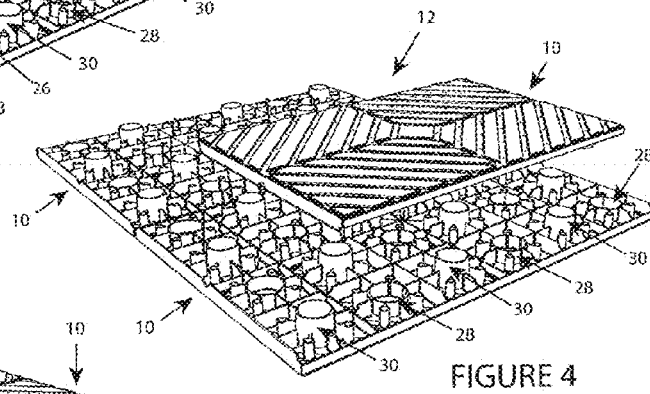
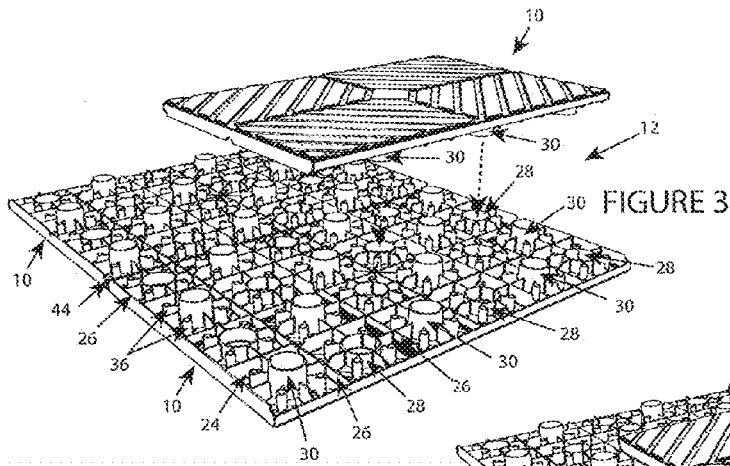

FIGURE 2





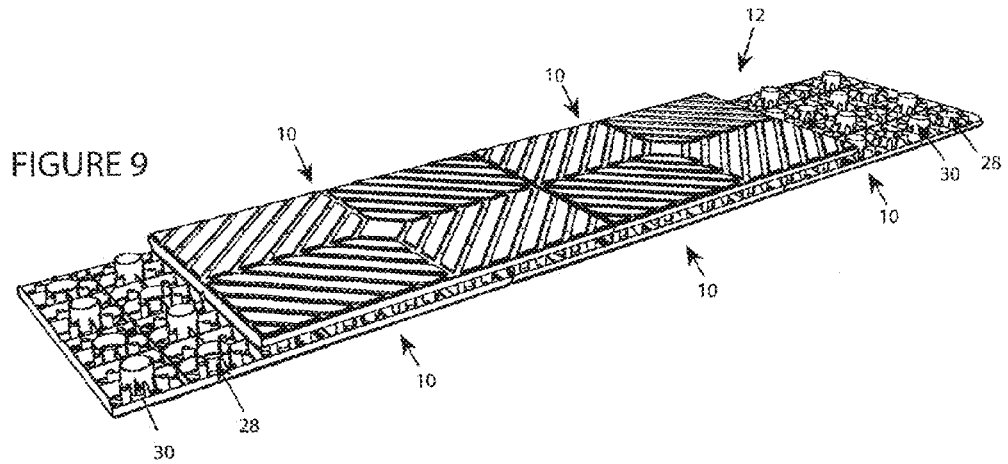
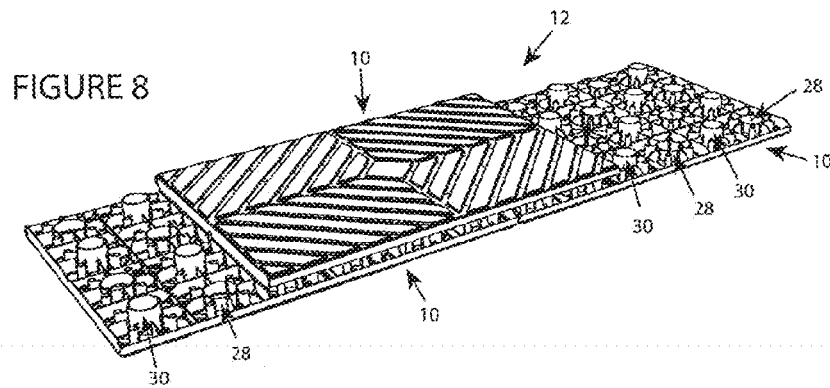
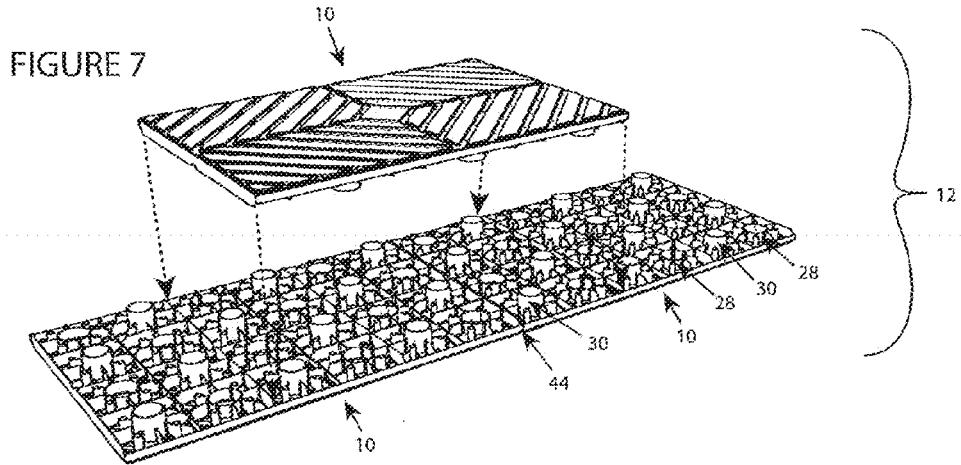

FIGURE 10 (a)

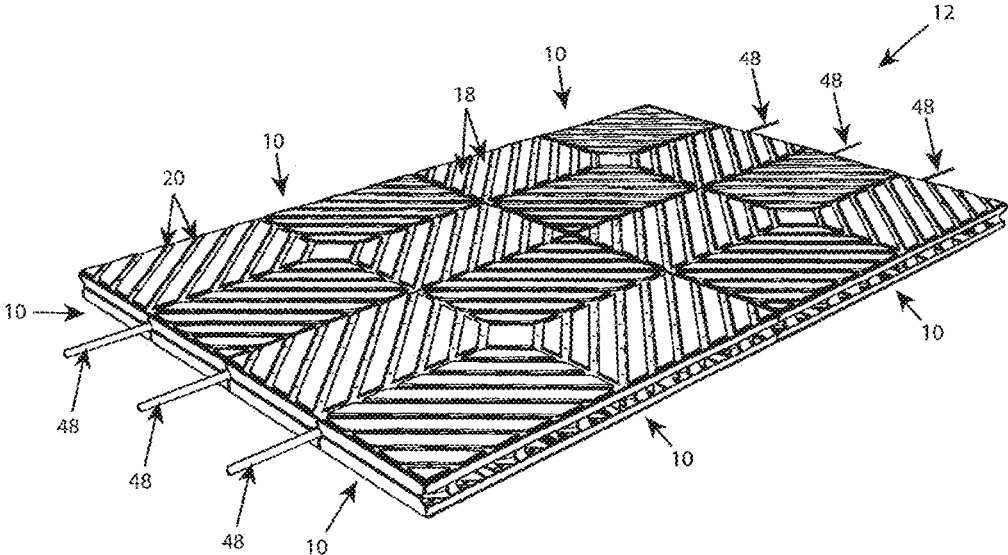

FIGURE 10 (b)

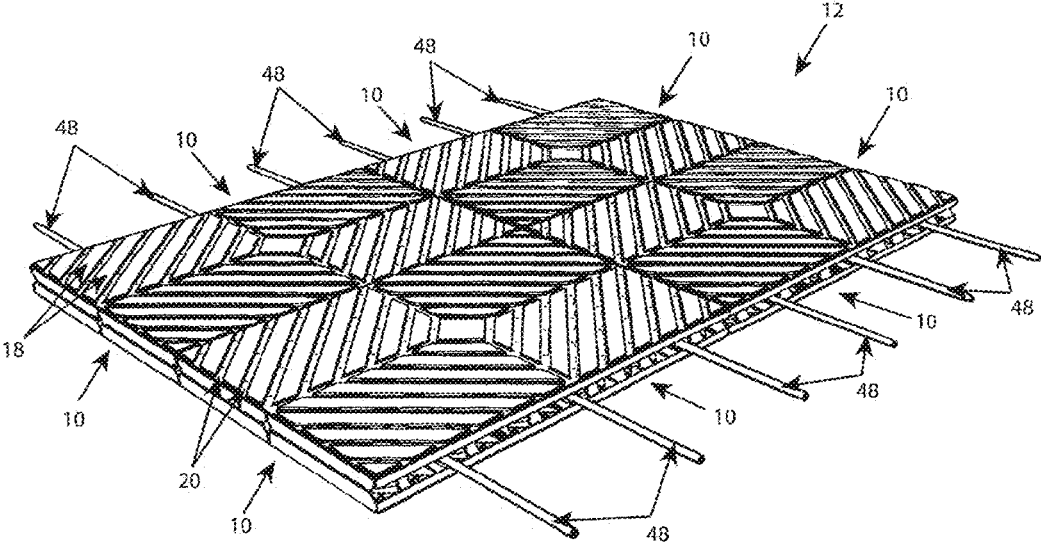

FIGURE 11

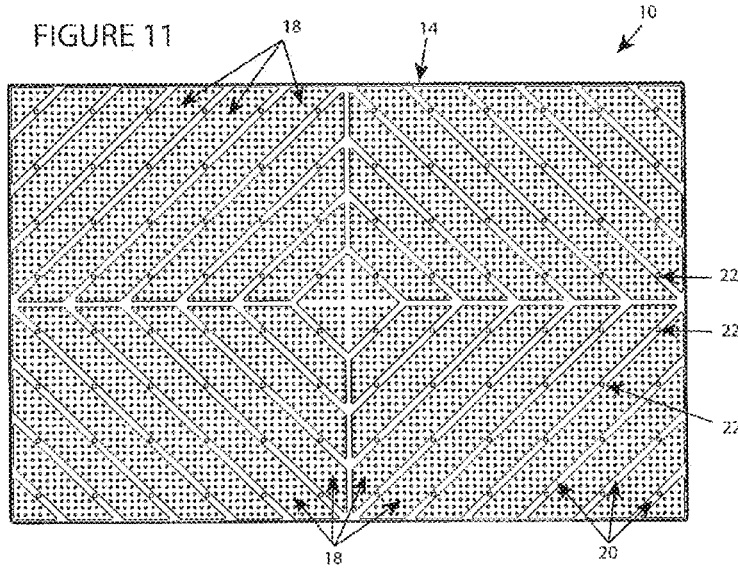

FIGURE 12

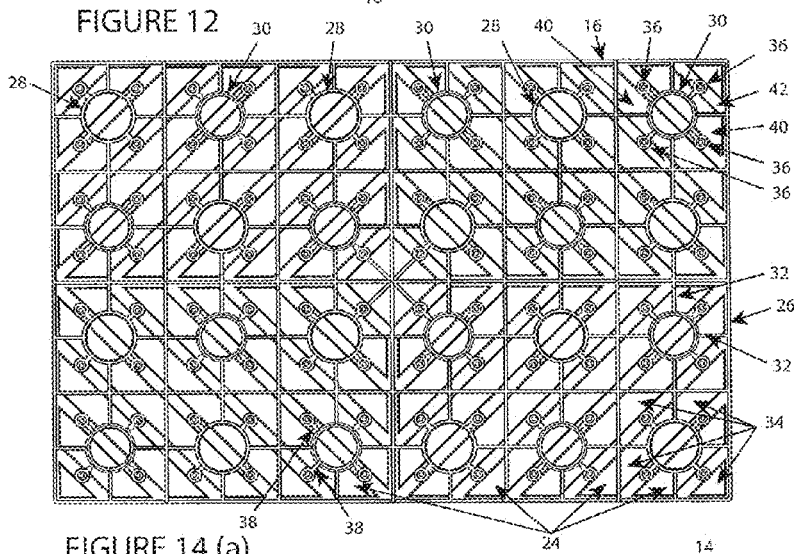

FIGURE 14 (a)

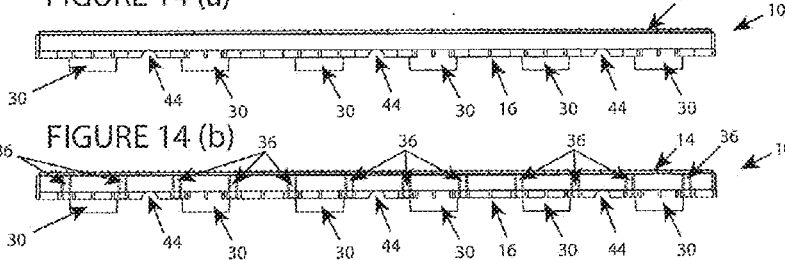

FIGURE 14 (b)

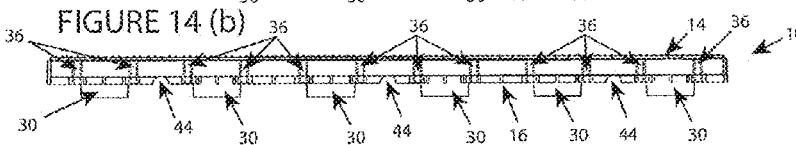

FIGURE 13 (a)

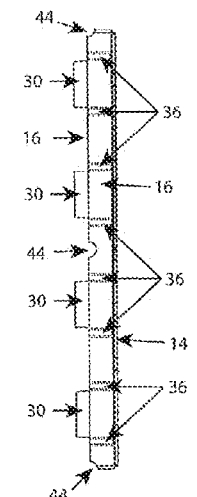
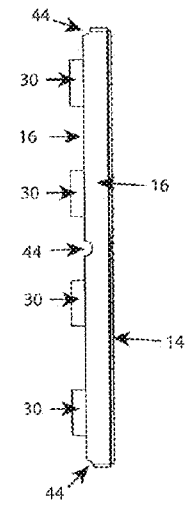
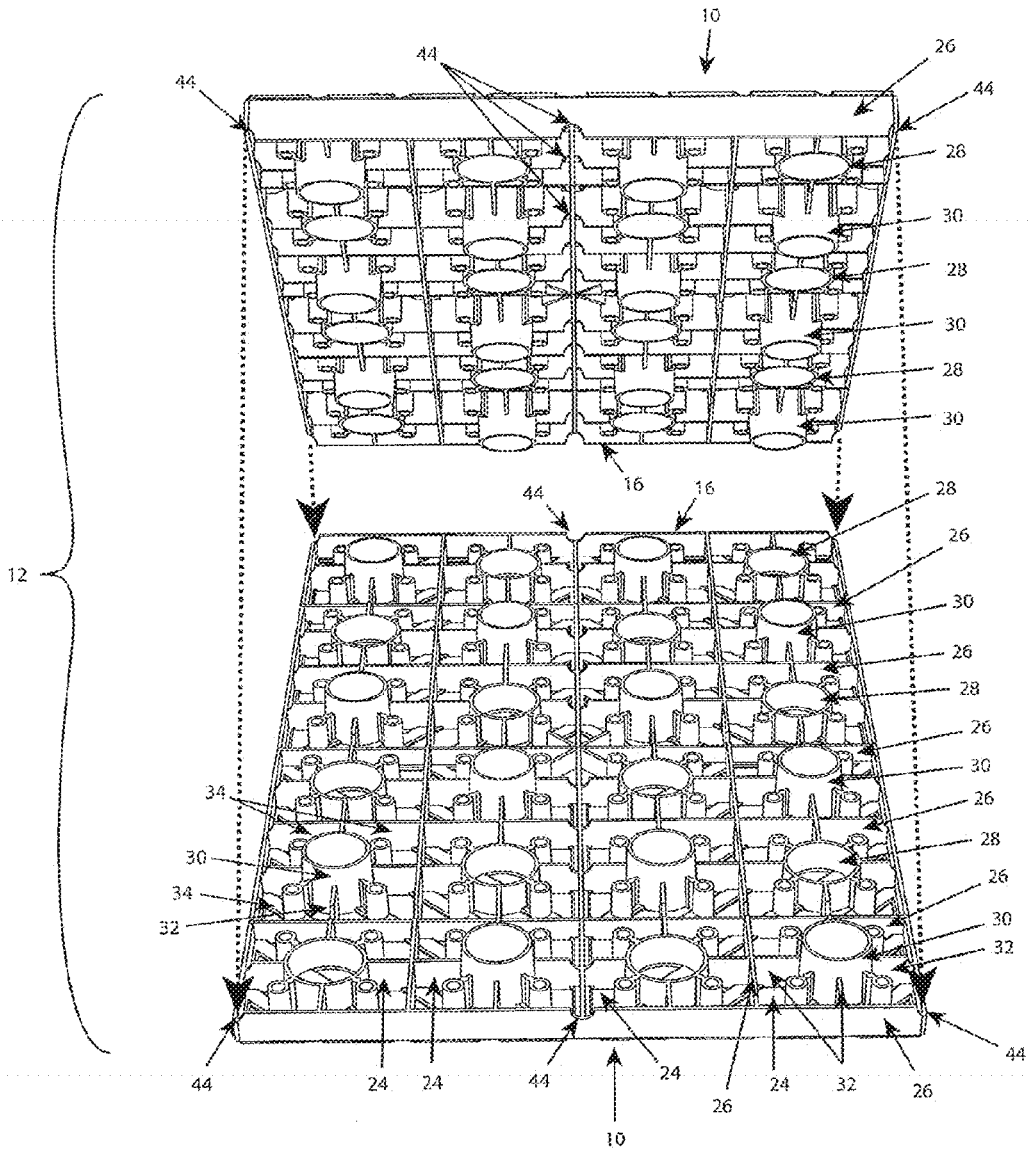

FIGURE 13 (b)

FIGURE 15



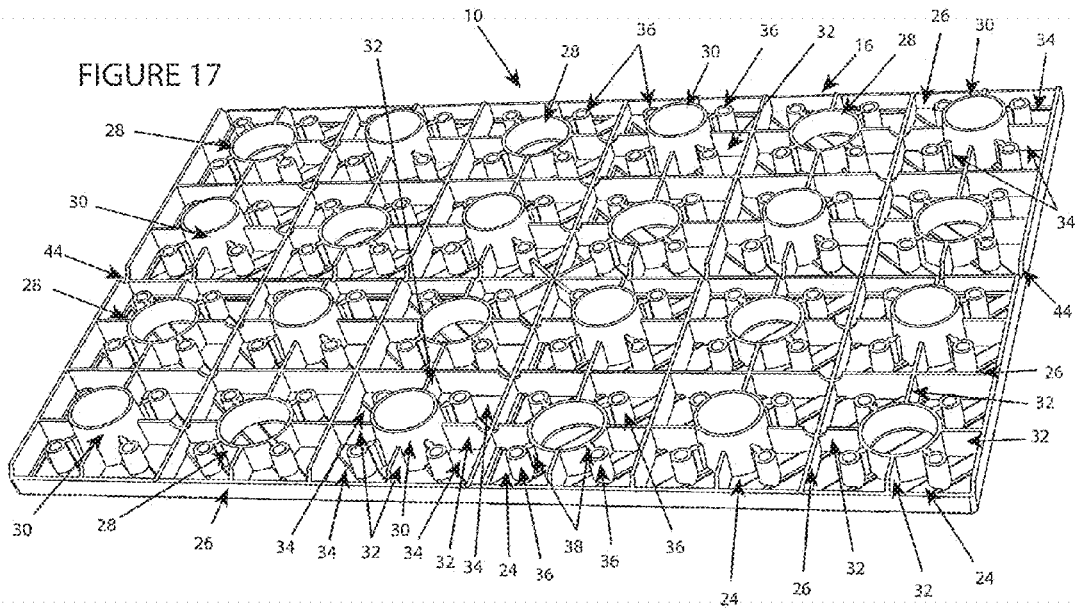
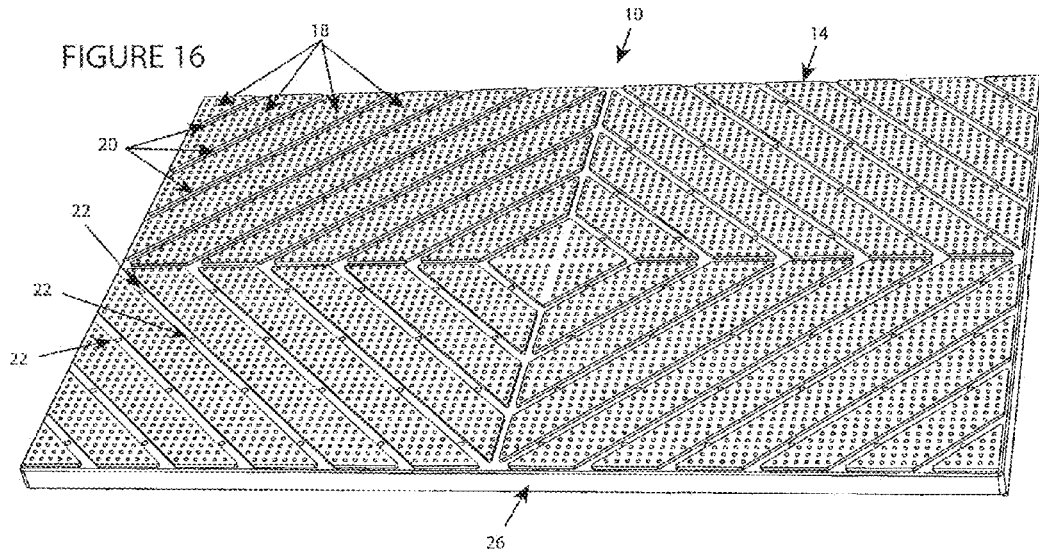



FIGURE 18

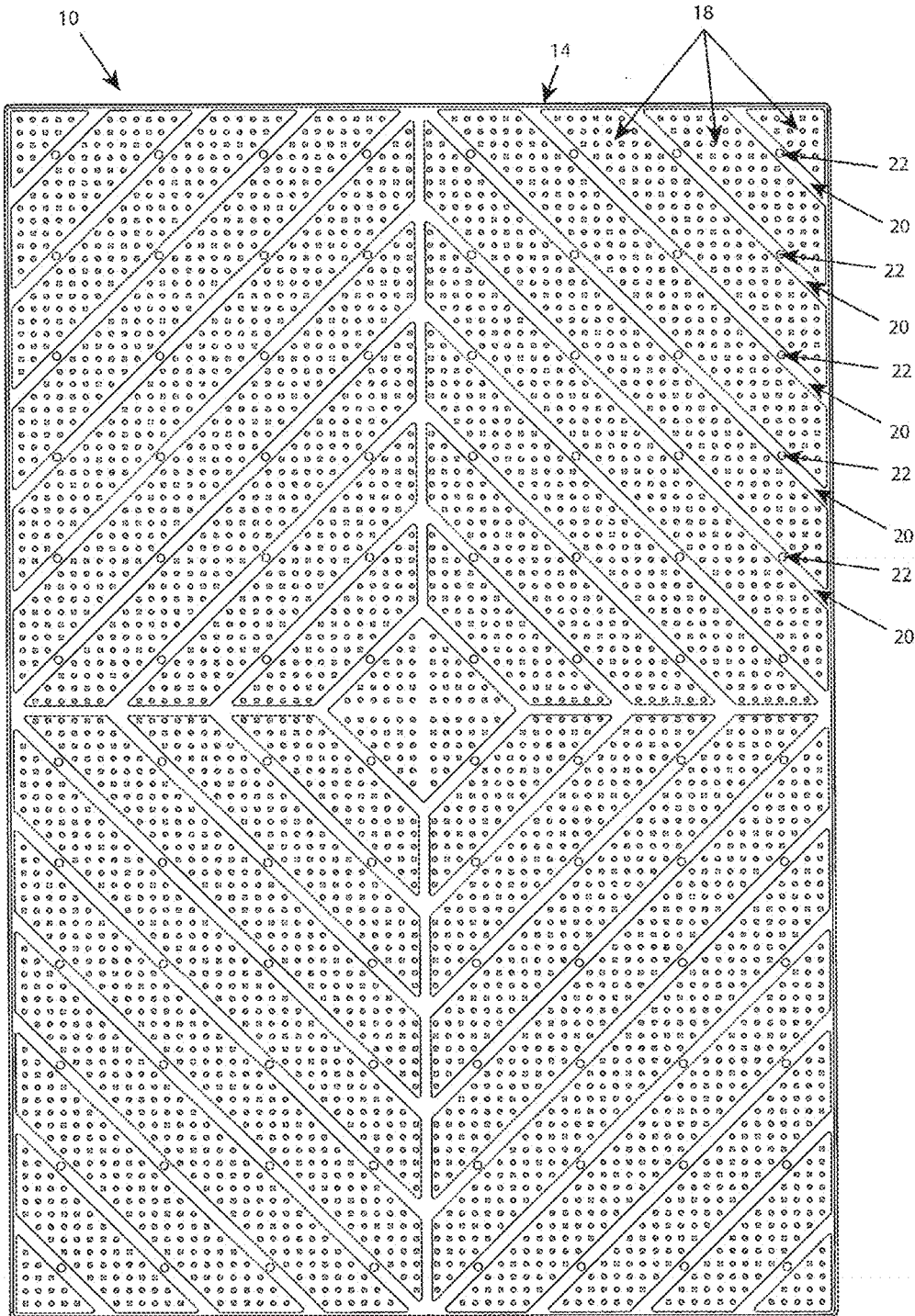

FIGURE 19

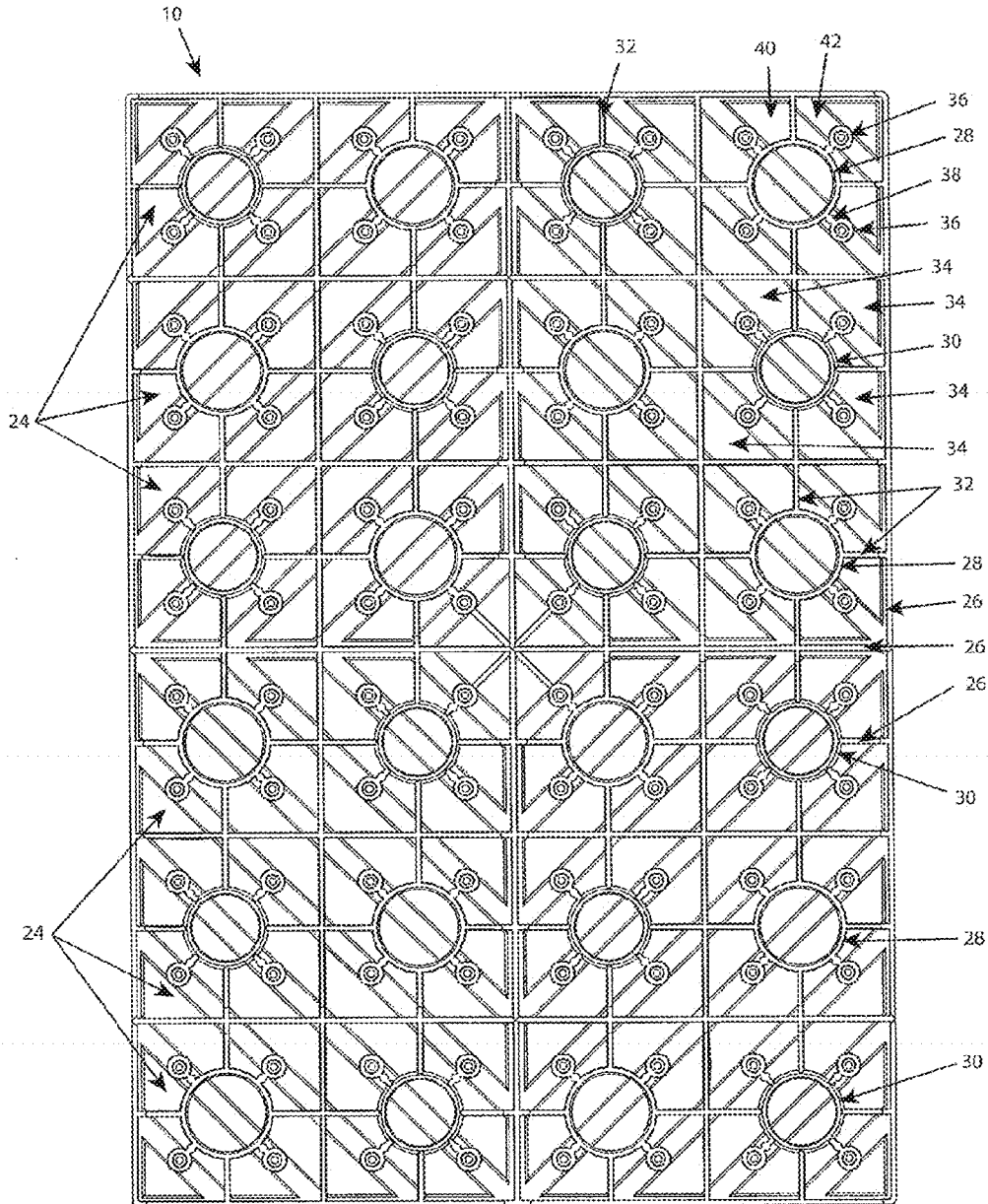

FIGURE 20 (a)

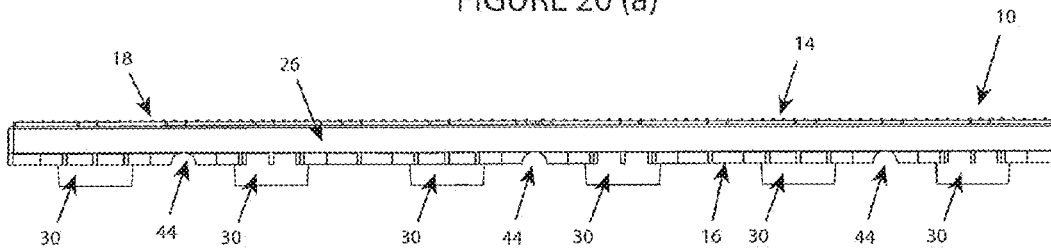

FIGURE 20 (b)

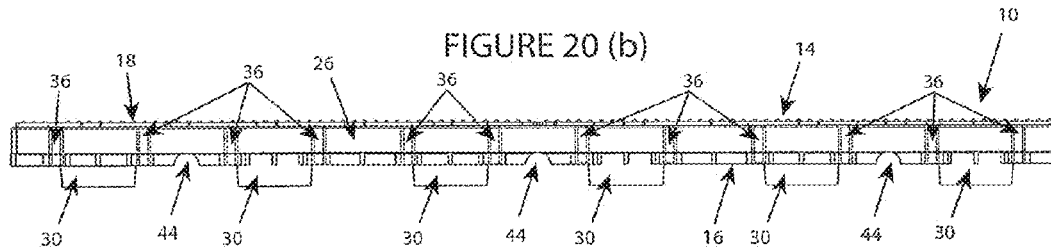

FIGURE 21 (a)

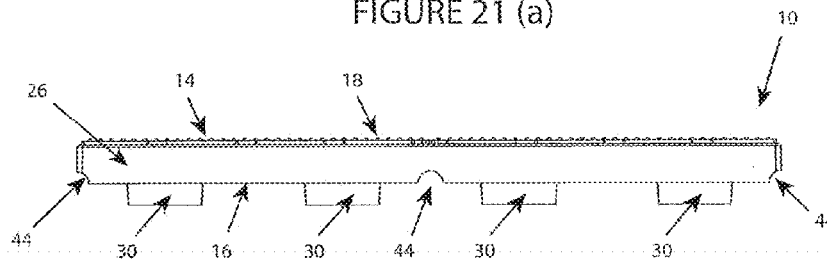

FIGURE 21 (b)

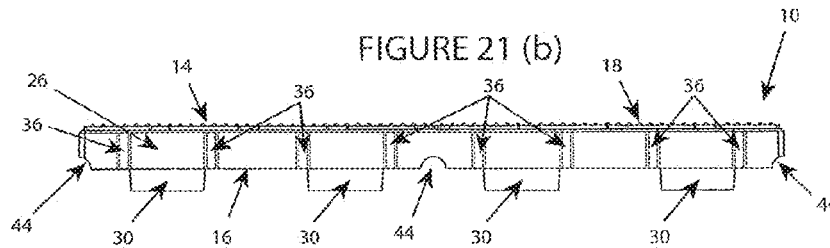
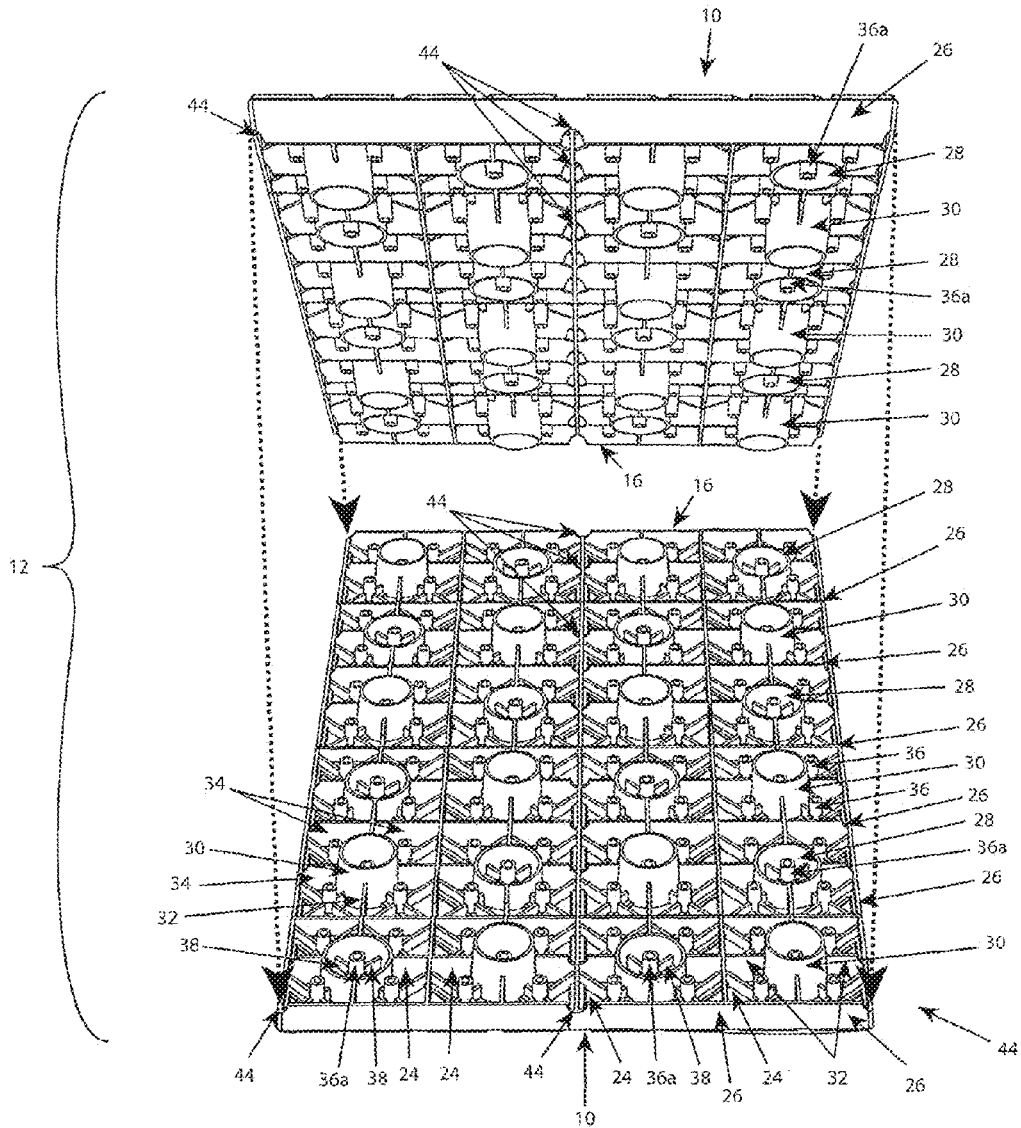

FIGURE 22



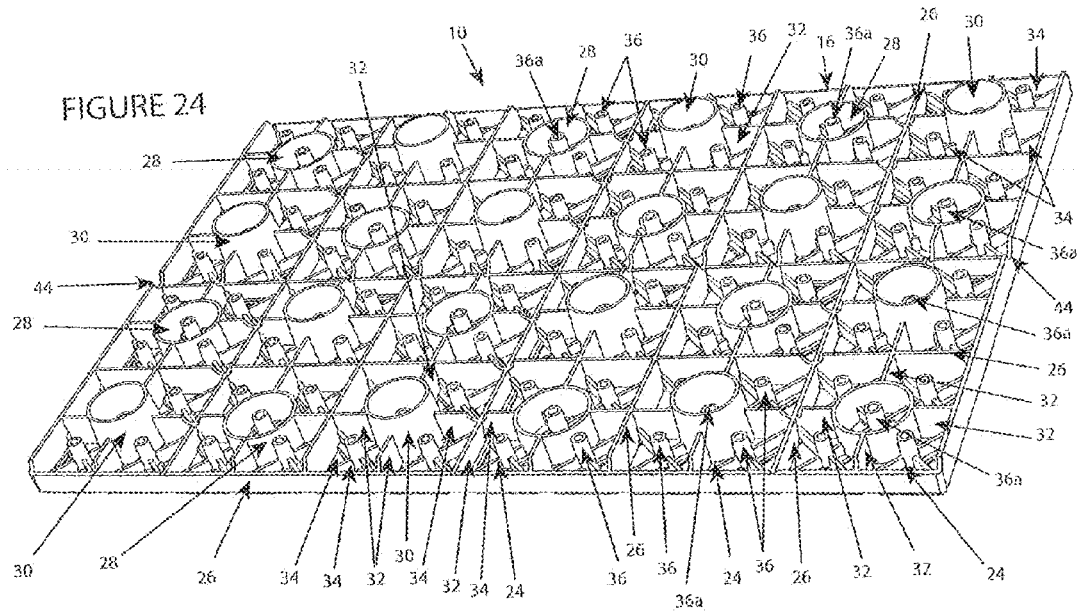
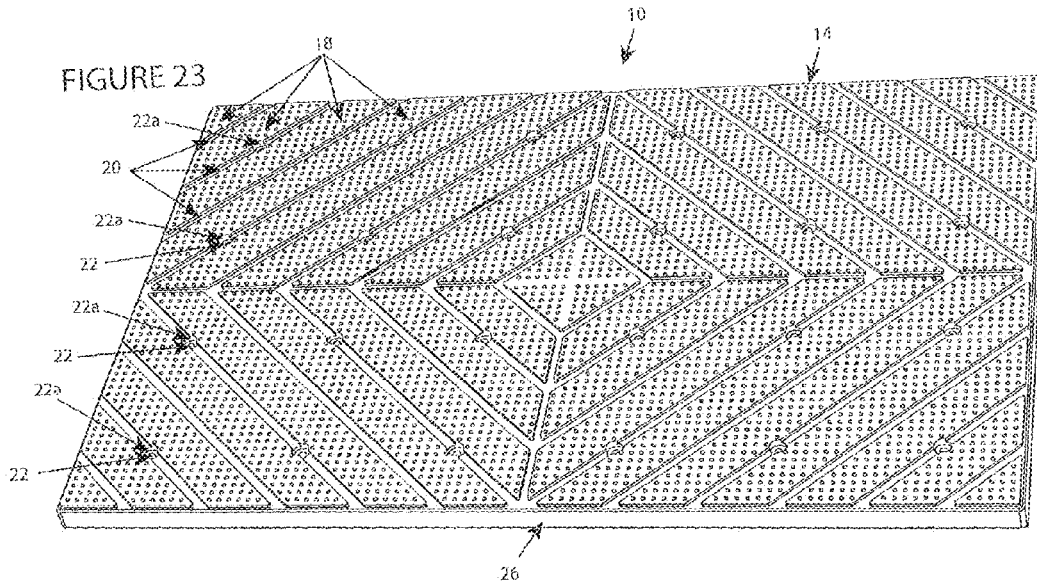

FIGURE 25

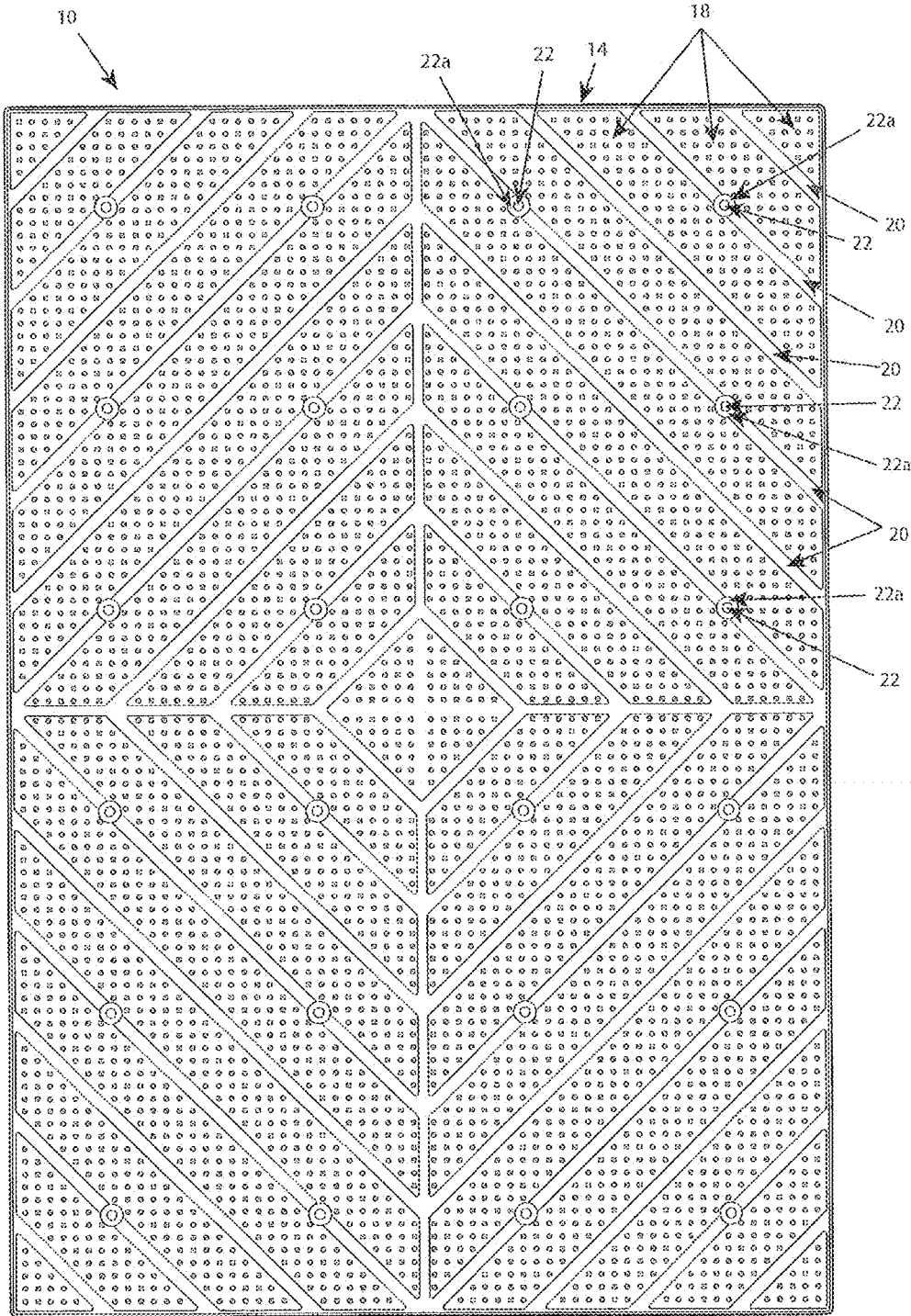

FIGURE 26

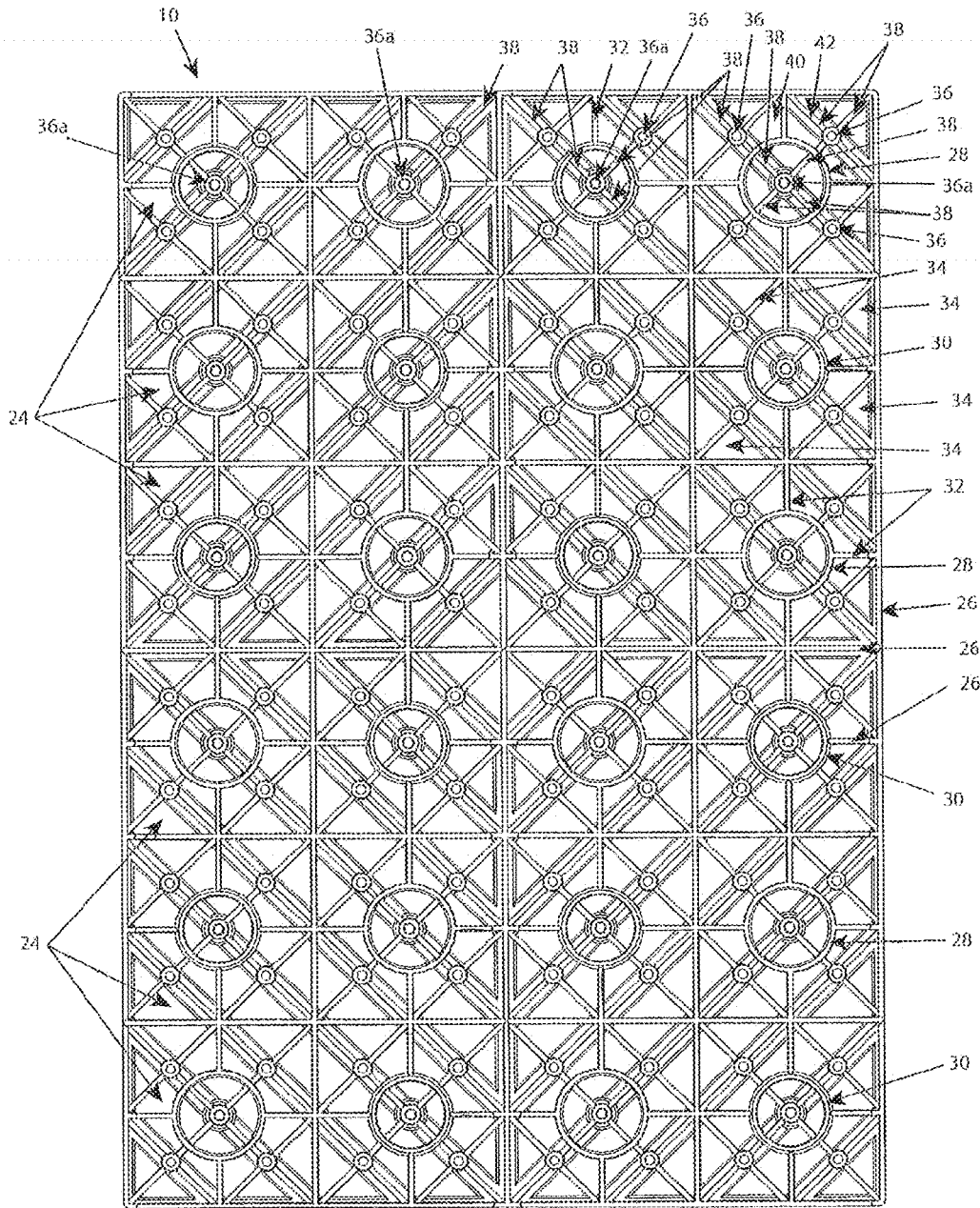

FIG. 27

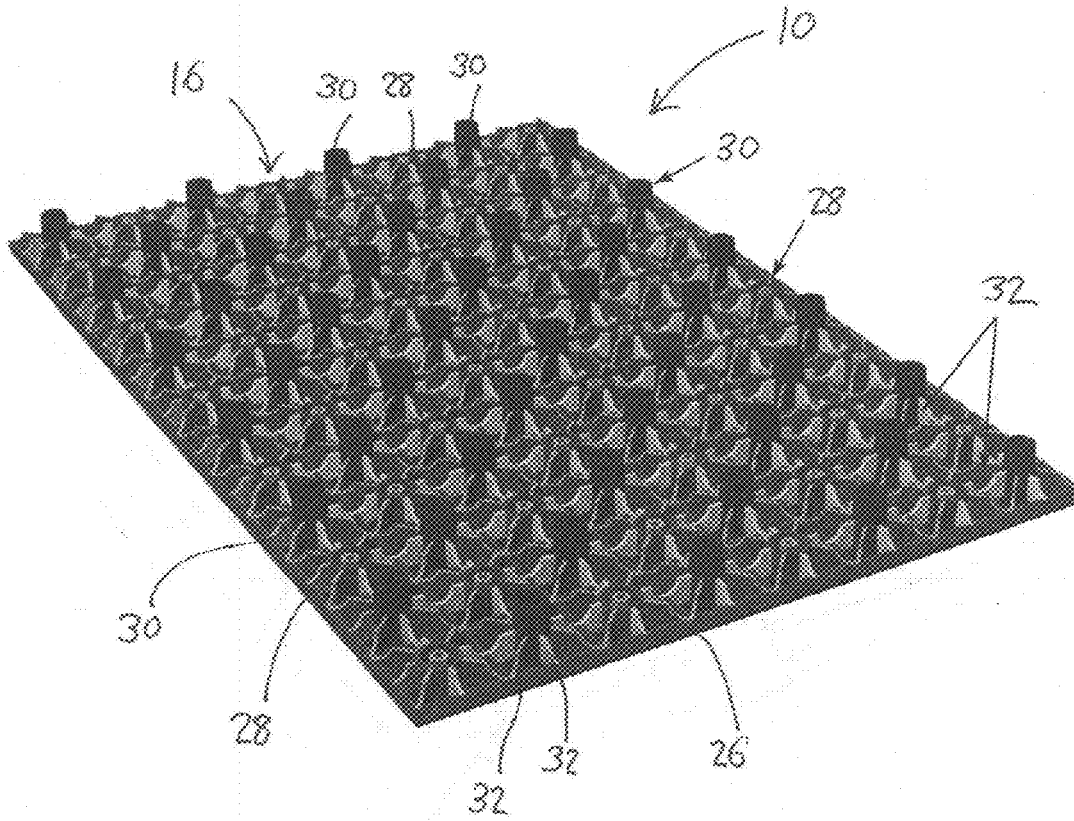

FIG. 27A

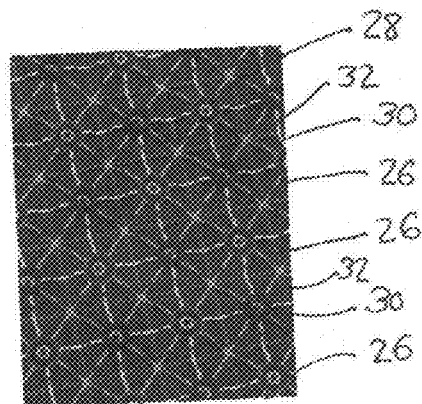



FIG. 28

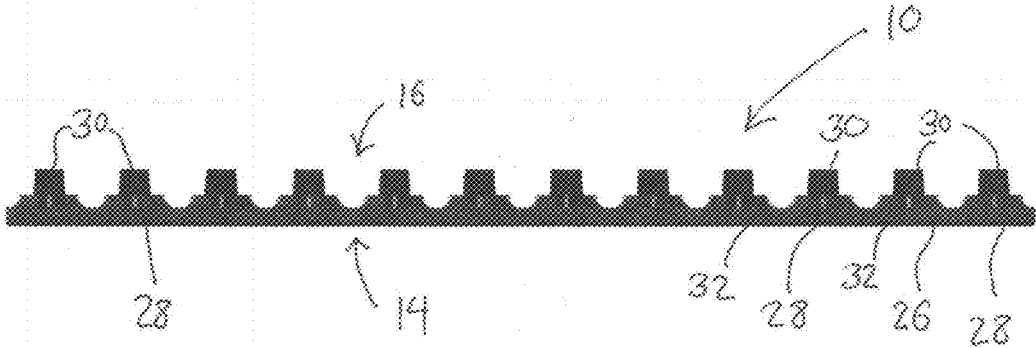

FIG. 29

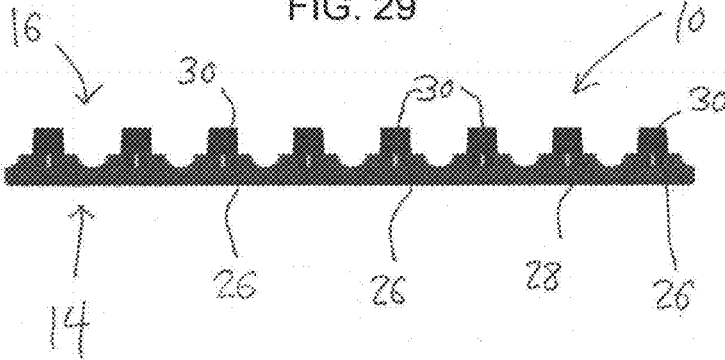

FIG. 30

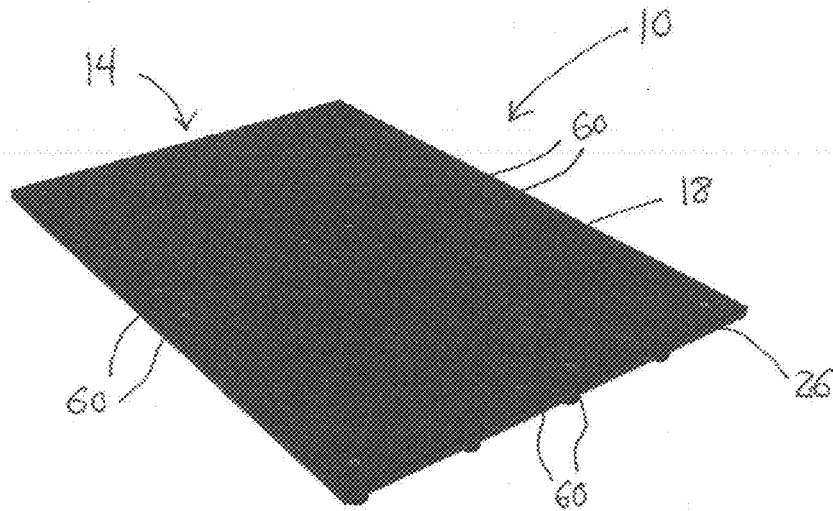

FIG. 31

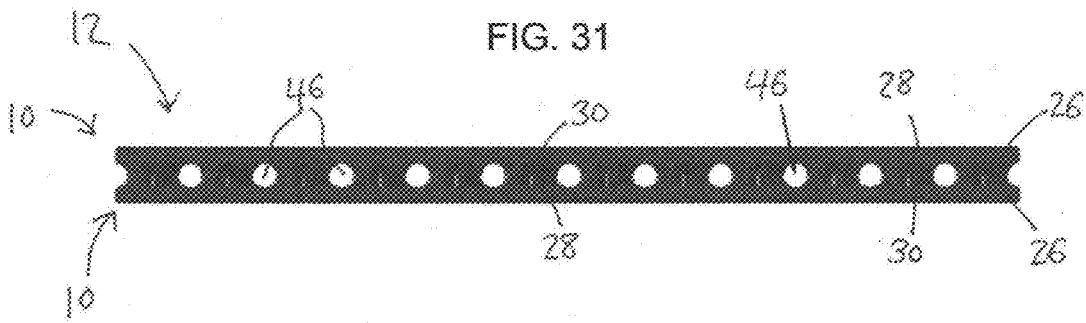

FIG. 32

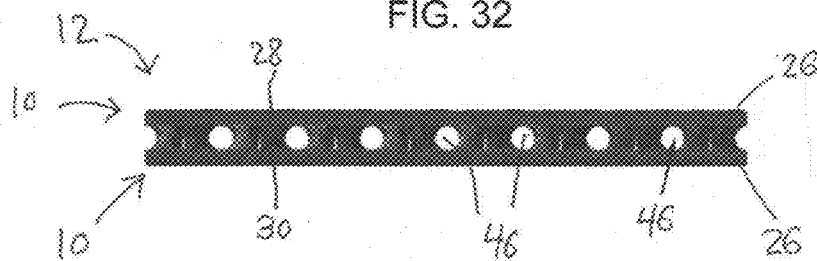

FIG. 33

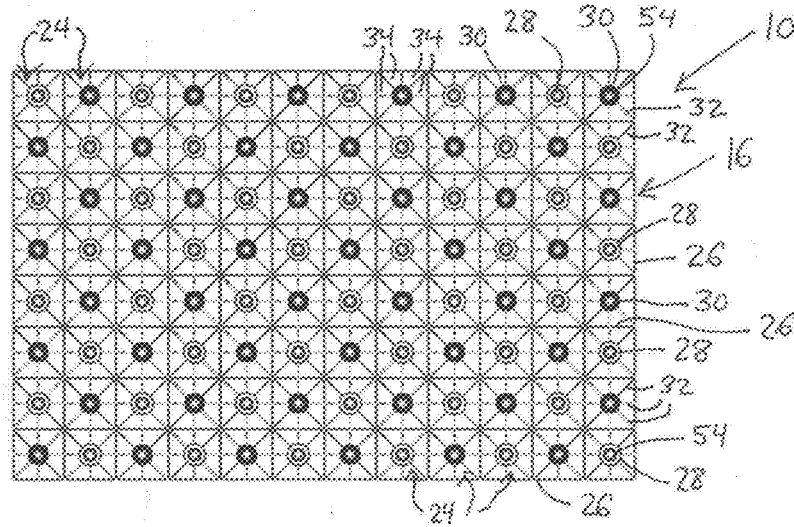

FIG. 34

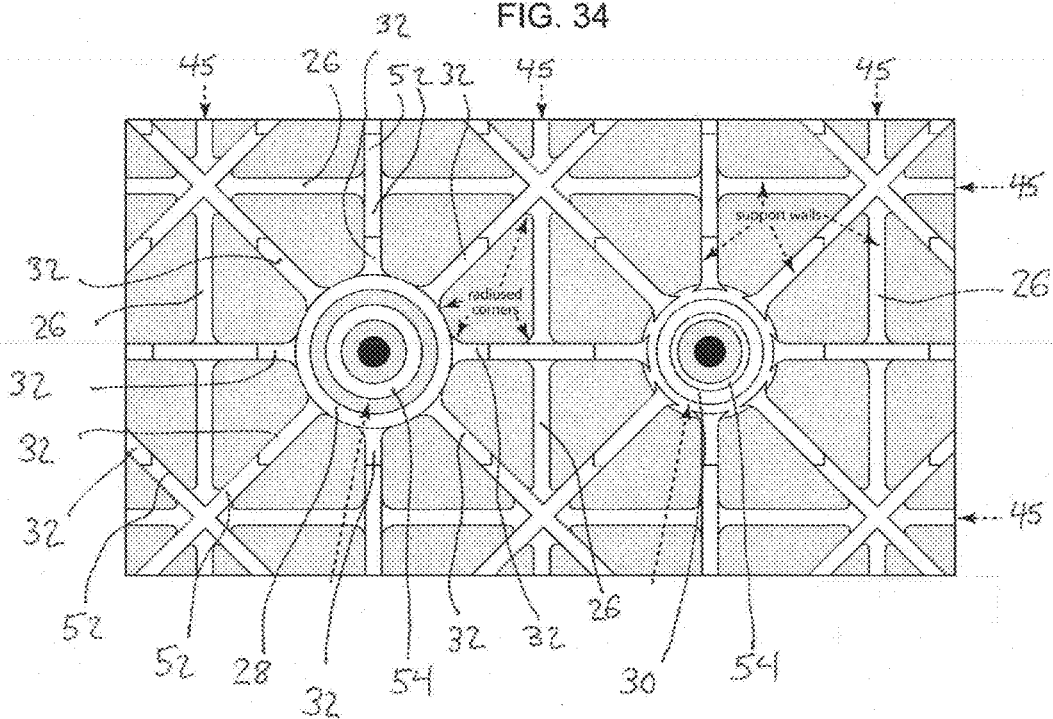

FIG. 35

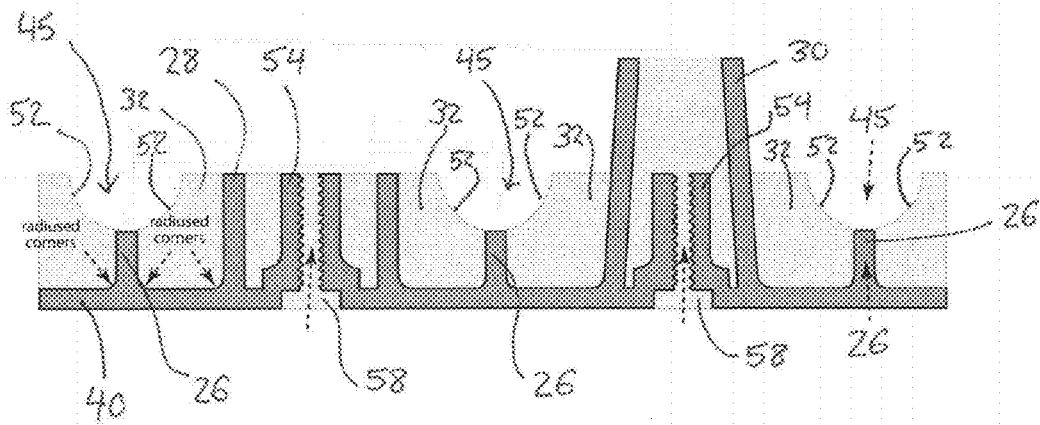

FIG. 36

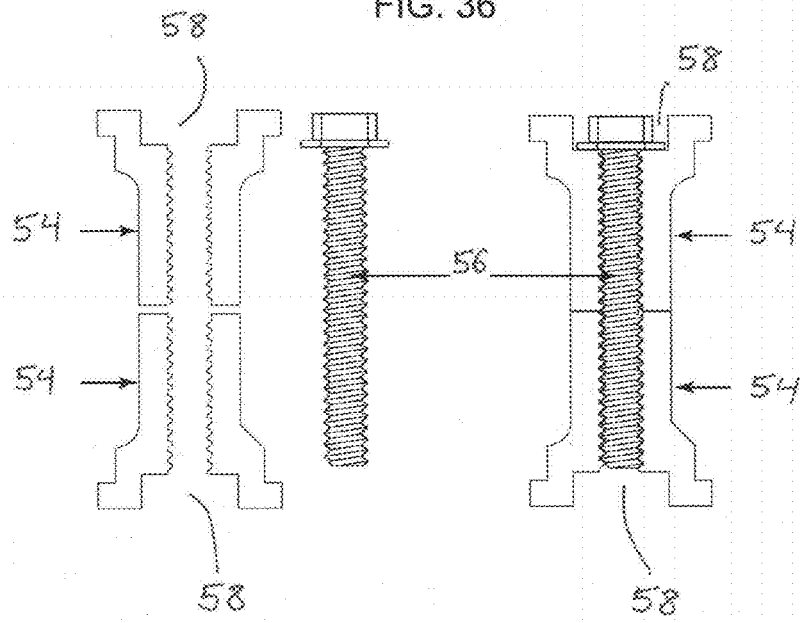

FIG. 37

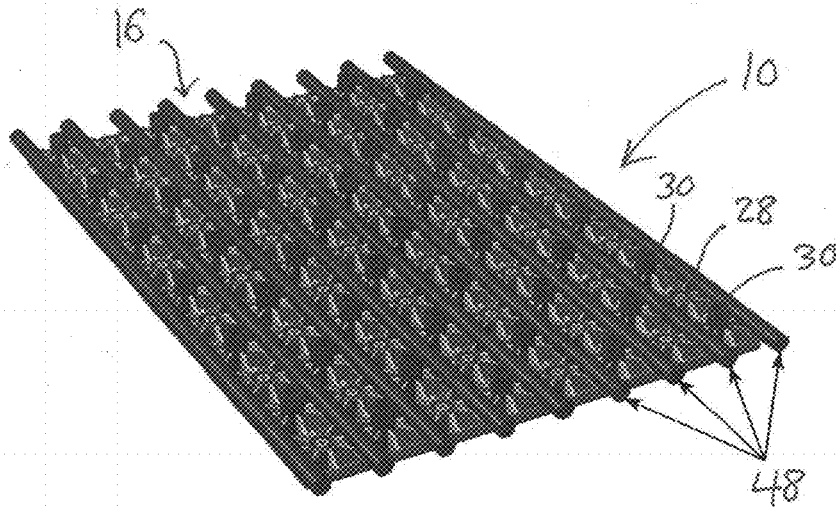

FIG. 38

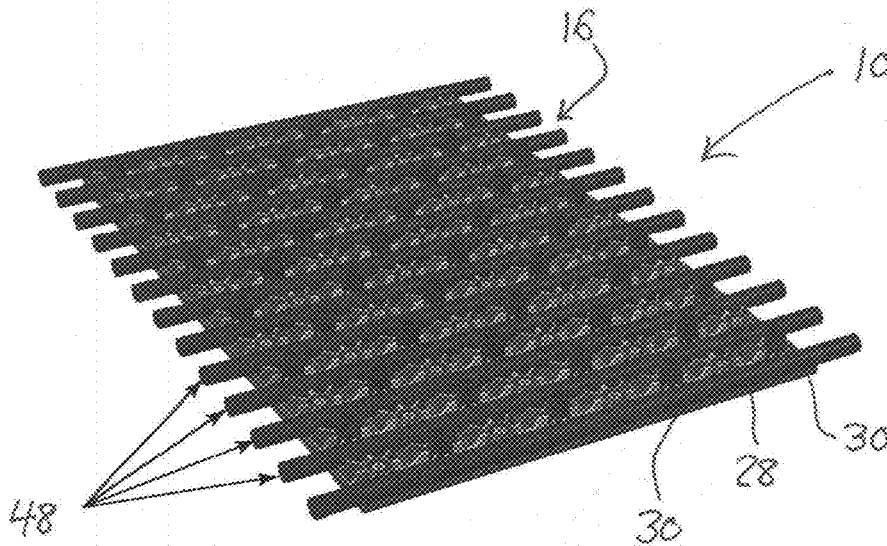

FIG. 39

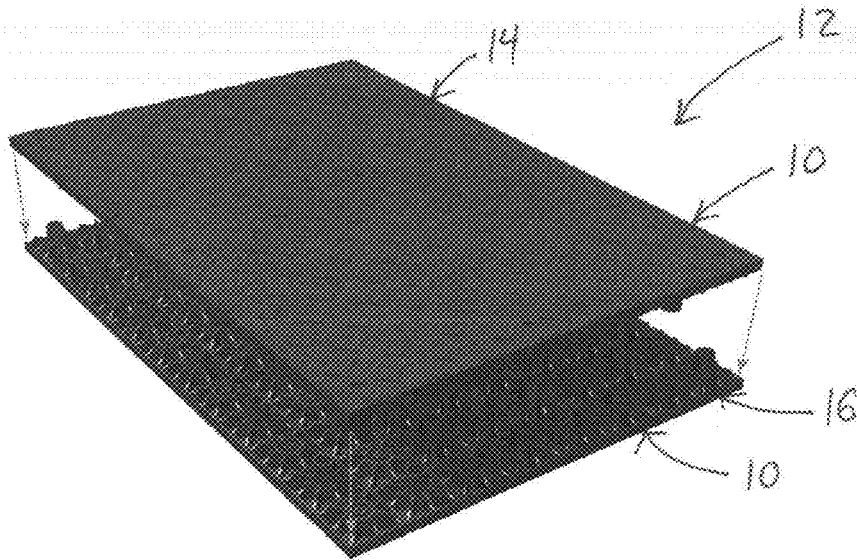

FIG. 40

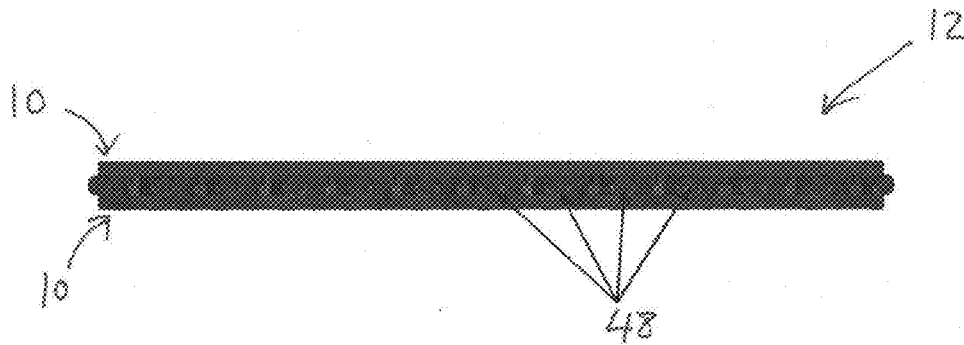
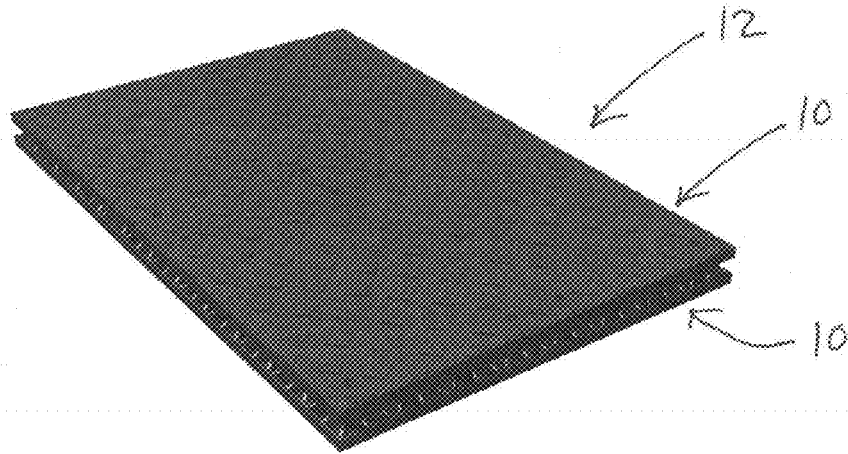

FIG. 41

FIG. 42

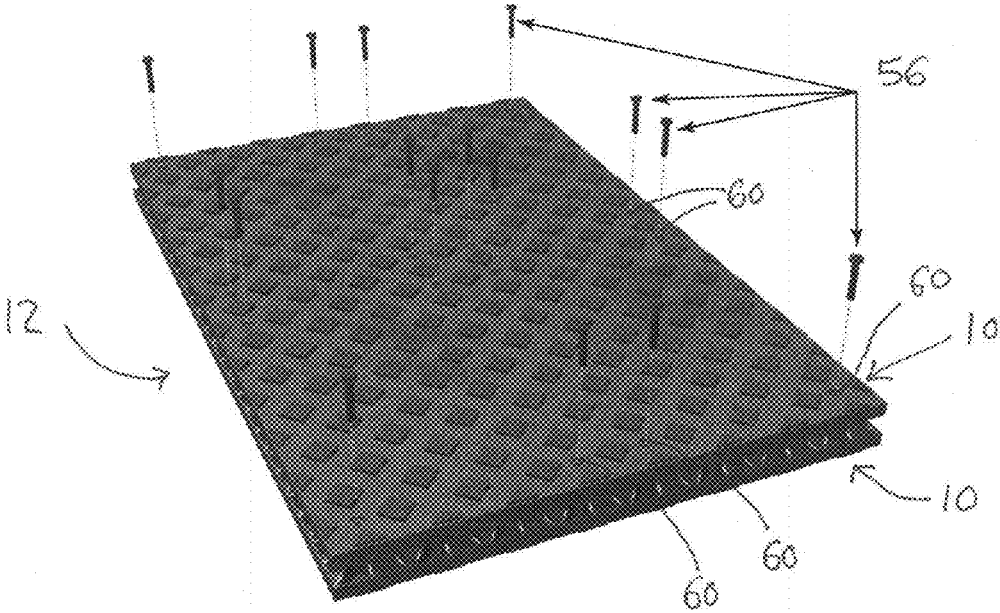

FIG. 43

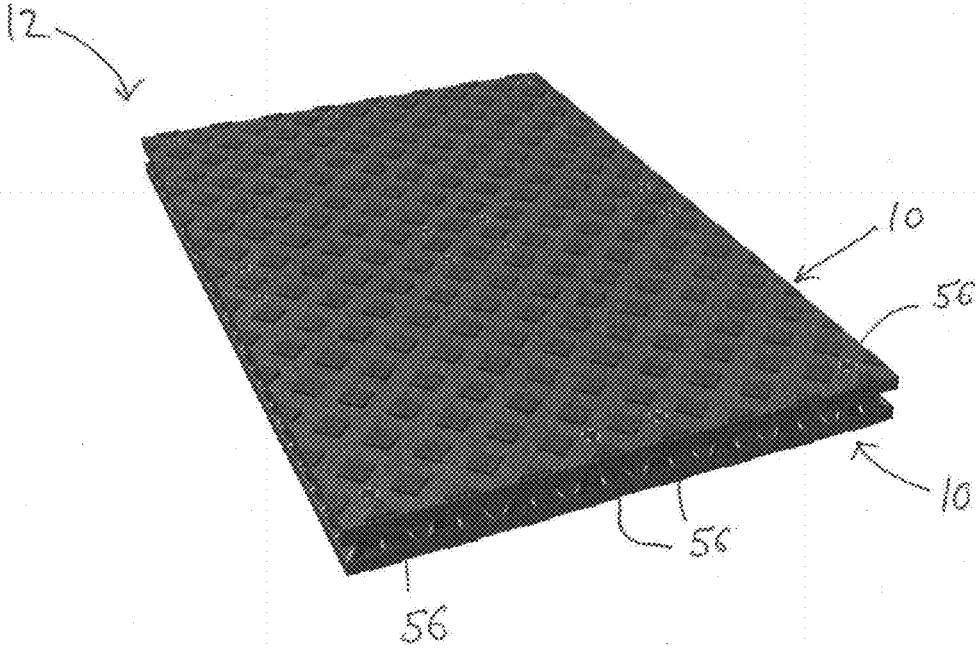

FIG. 44

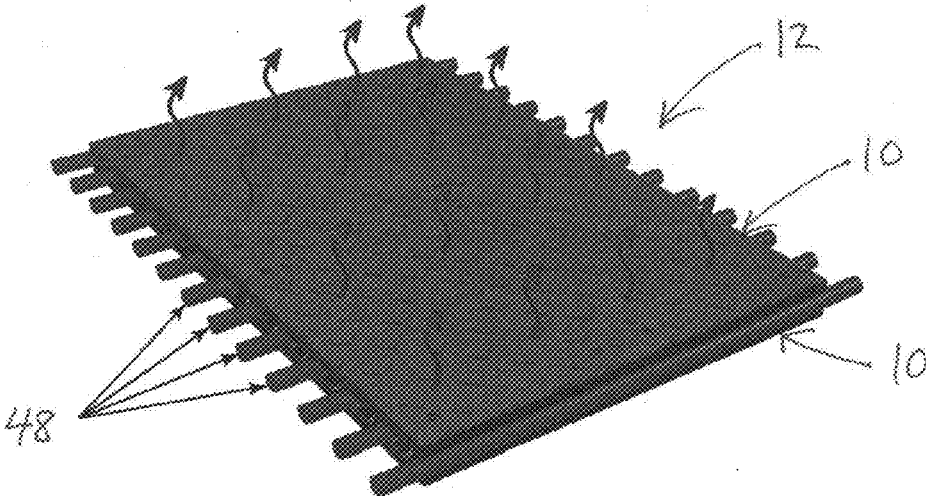

FIG. 45

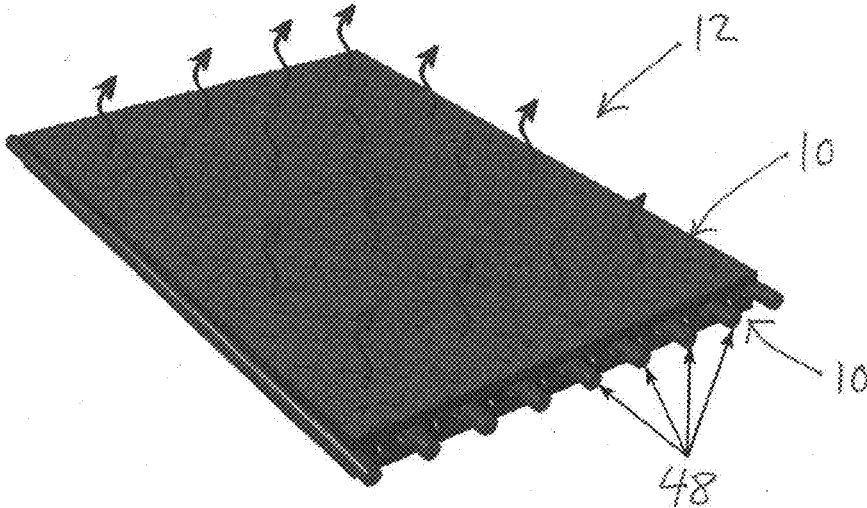



FIG. 46

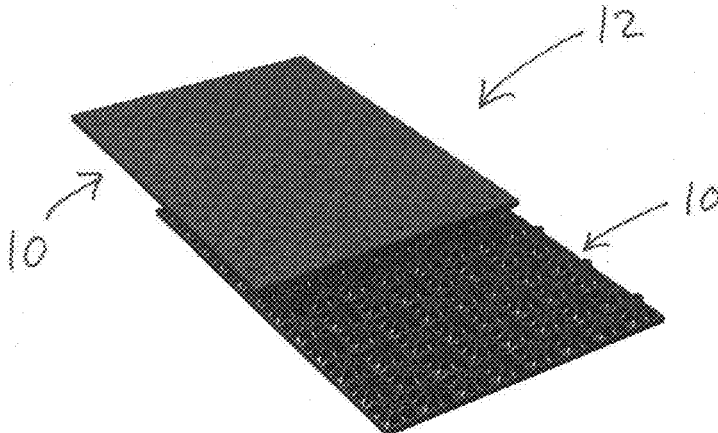

FIG. 47

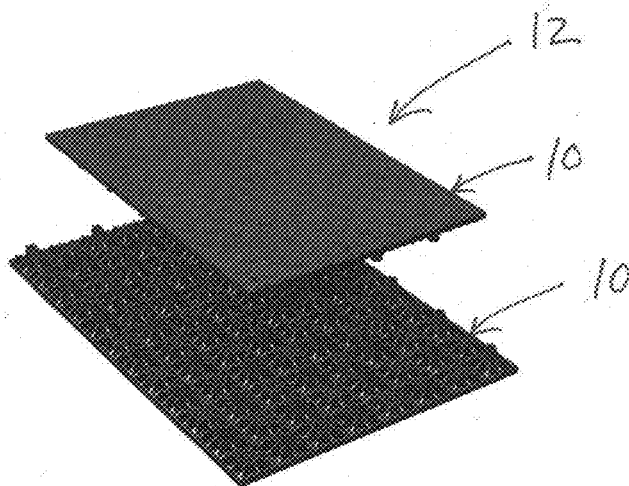

FIG. 48

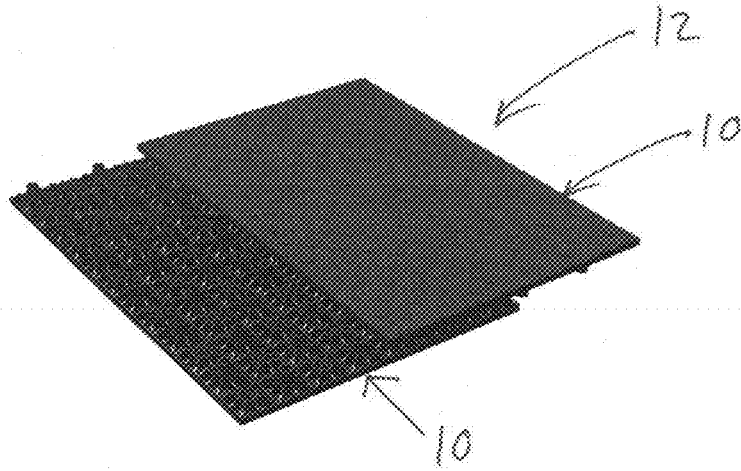

FIG. 49

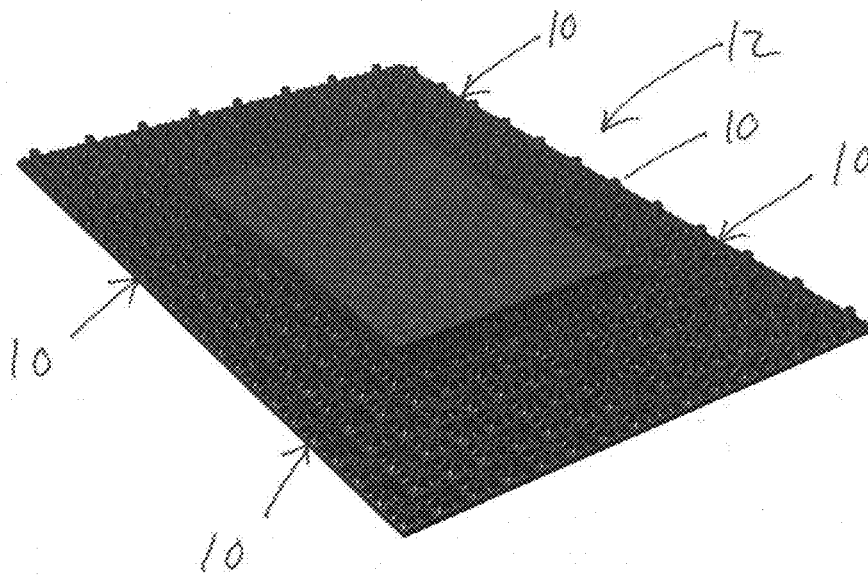
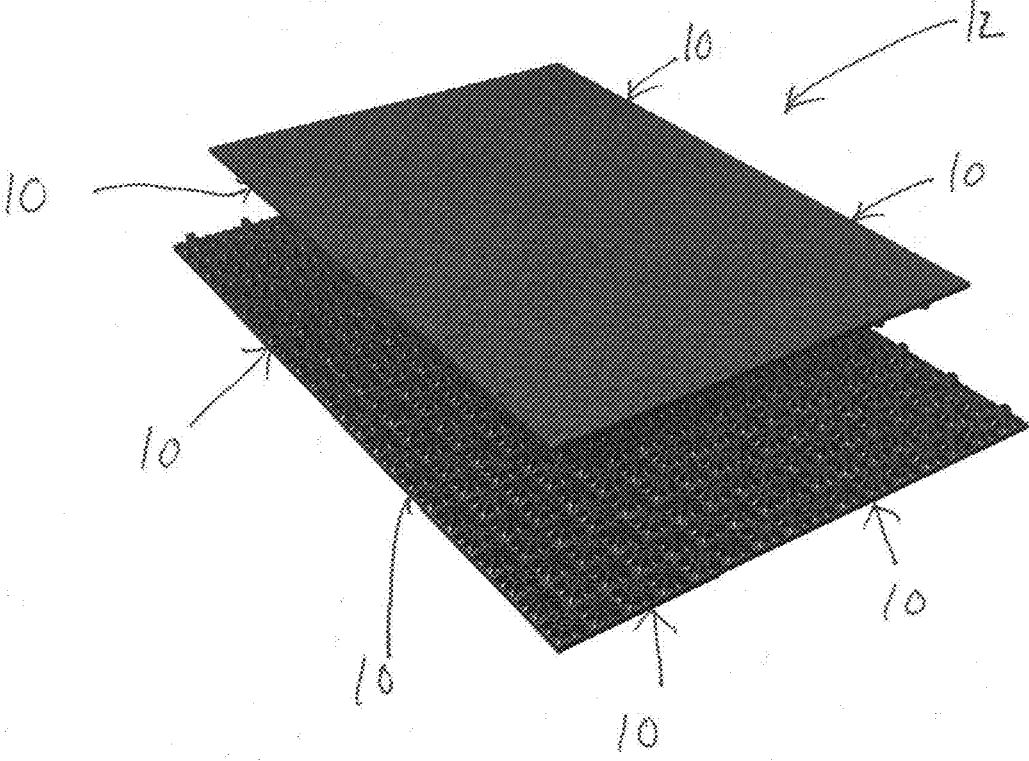

FIG. 50



**CONSTRUCTION PANEL**

## RELATED APPLICATIONS

**[0001]** The application is a continuation of U.S. patent application Ser. No. 13/919,906 filed 17 Jun. 2013 which is a continuation-in-part of U.S. patent application Ser. No. 11/874,388 filed 18 Oct. 2007, now U.S. Pat. No. 8,464,490, which is a continuation-in-part of application Ser. No. 11/746,301 filed 9 May 2007. The disclosure of each of the previously referenced US patent applications is hereby incorporated by reference in its entirety.

## TECHNICAL FIELD

**[0002]** This application relates to a multi-purpose construction panel.

## BACKGROUND

**[0003]** Modular panels may be used for many different types of construction applications. For example, interlocking panels may be used to form temporary flooring, roofing or wall structures. Other potential commercial applications are described in applicant's U.S. Pat. No. 7,914,228 issued 29 Mar. 2011 entitled MULTI-PURPOSE CONSTRUCTION MODULE, which is hereby incorporated by reference in its entirety.

**[0004]** There is a need for light-weight, economical construction panels particularly suitable for sale directly to consumers at building supply retail outlets and the like. There is a particular need for construction panels which may be quickly and easily coupled together without the need for specialized tools or skills to form a wide variety of construction assemblies.

## SUMMARY OF INVENTION

**[0005]** In accordance with the invention, a construction panel having a first side and a second side is provided. The first side comprises a substantially planar deck and the second side comprises a plurality of first wall elements defining a plurality of compartments therebetween and a plurality of sleeves each located in one of the compartments. The sleeves may include a first group of female sleeves having a first height and a second group of male sleeves having a second height exceeding the first height, wherein the male sleeves of one of the panels are sized to fit within the female sleeves of another one of the panels (i.e. when a pair of panels are coupled together with their respective second sides facing inwardly). The male and female sleeves may be arranged in an alternating array on the second side of each panel.

**[0006]** In one embodiment, at least some of the wall elements may include notches formed on an edge portion thereof. When a pair of panels are coupled together to form a construction assembly, the notches together define a conduit extending through the interior of the assembly. A fluid delivery tube may be deployed within a conduit for circulating fluid through the assembly, such as heated air or water for regulating the temperature or other physical characteristics of the assembly.

**[0007]** The invention comprises both single construction panels and construction assemblies formed from two or more panels.

## BRIEF DESCRIPTION OF DRAWINGS

**[0008]** In drawings which describe embodiments of the invention but which should not be construed as restricting the spirit or scope thereof,

**[0009]** FIG. 1 is an exploded, isometric view of two mating construction panels configured in accordance with the invention.

**[0010]** FIG. 2 is an isometric view of the construction panels of FIG. 1 in an assembled configuration.

**[0011]** FIG. 3 is an exploded, isometric view of multiple bottom construction panels aligned adjacent one another and showing a single top panel.

**[0012]** FIG. 4 is an isometric view of the assembly of FIG. 3 showing the panels assembled together with the top panel in an overlapping orientation.

**[0013]** FIG. 5 is an isometric view similar to FIG. 4 showing multiple top panels.

**[0014]** FIG. 6 is an isometric view similar to FIG. 4 showing multiple top and bottom panels coupled together.

**[0015]** FIG. 7 is an exploded, isometric view similar to FIG. 3 showing the bottom panels arranged in an elongated pattern and showing a single top panel.

**[0016]** FIG. 8 is an isometric view of the assembly of FIG. 7 showing the panels assembled together with the top panel in longitudinal alignment with the bottom panels.

**[0017]** FIG. 9 is an isometric view similar to FIG. 8 showing two top panels.

**[0018]** FIG. 10(a) is an isometric view of an assembly comprising multiple construction panels coupled together and showing fluid delivery tubes extending through conduits defined within the interior of the assembly.

**[0019]** FIG. 10(b) is an isometric view of the assembly of FIG. 10(a) showing the fluid delivery tubes in a different direction.

**[0020]** FIG. 11 is a plan view of a first surface of a single construction panel.

**[0021]** FIG. 12 is a plan view of a second surface of a construction panel.

**[0022]** FIG. 13(a) is a first end elevational view of the panel.

**[0023]** FIG. 13(b) is a second end elevational view of the panel.

**[0024]** FIG. 14(a) is a first side elevational view of the panel.

**[0025]** FIG. 14(b) is a second side end elevational view of the panel.

**[0026]** FIG. 15 is an exploded, end isometric view of two mating construction panels configured in accordance with the invention.

**[0027]** FIG. 16 is an isometric view showing the first surface of a single construction panel.

**[0028]** FIG. 17 is an isometric view showing the second surface of a single construction panel.

**[0029]** FIG. 18 is an enlarged, top plan view of the first surface of the panel similar to FIG. 11.

**[0030]** FIG. 19 is an enlarged, top plan view of a second surface of the panel similar to FIG. 12.

**[0031]** FIG. 20(a) is a first side elevational view of a single panel.

**[0032]** FIG. 20(b) is a second side elevational view of a modified embodiment of the panel.

**[0033]** FIG. 21(a) is a first end elevational view of single panel.

[0034] FIG. 21(b) is a second end elevational view of a single panel.

[0035] FIG. 22 is an exploded, end isometric view of two mating construction panels configured in accordance with an alternative embodiment the invention.

[0036] FIG. 23 is an isometric view showing the first surface of a single construction panel of FIG. 22.

[0037] FIG. 24 is an isometric view showing the second surface of a single construction panel of FIG. 22.

[0038] FIG. 25 is an enlarged, top plan view of the first surface of the panel of FIG. 22.

[0039] FIG. 26 is an enlarged, top plan view of a second surface of the panel of FIG. 22.

[0040] FIG. 27 is an isometric view showing the second side of a construction panel in accordance with a further alternative embodiment of the invention.

[0041] FIG. 27A is an enlarged top view of a portion of the panel of FIG. 27.

[0042] FIG. 28 is a side elevational view of the panel of FIG. 27.

[0043] FIG. 29 is an end elevational view of the panel of FIG. 27.

[0044] FIG. 30 is an isometric view showing the first side of the panel of FIG. 27.

[0045] FIG. 31 is a side elevational view of an assembly comprising two mating construction panels of FIG. 27.

[0046] FIG. 32 is an end elevational view of the assembly of FIG. 31.

[0047] FIG. 33 is a top plan view of the second side of the panel of FIG. 27 showing the arrangement of alternating male and female sleeves.

[0048] FIG. 34 is an enlarged, top plan view of a portion of the panel of FIG. 33 showing adjacent male and female sleeves.

[0049] FIG. 35 is an enlarged, side view of a portion of the panel of FIG. 33 showing adjacent male and female sleeves, each of the sleeves having threaded bolt posts.

[0050] FIG. 36 is an enlarged, side elevational view showing pairs of threaded bolt posts aligned on mating panels and a bolt for coupling the bolt posts together.

[0051] FIG. 37 is an isometric view of the panel of FIG. 27 with a plurality of fluid delivery tubes extending longitudinally in conduit channels.

[0052] FIG. 38 is an isometric view of the panel of FIG. 27 with a plurality of fluid delivery tubes extending laterally in conduit channels.

[0053] FIG. 39 is an exploded isometric view of an assembly comprising two mating construction panels of FIG. 27.

[0054] FIG. 40 is an isometric view of the assembly of FIG. 39 with the construction panels coupled together.

[0055] FIG. 41 is a side elevational view of the assembly of FIGS. 39 and 40 and showing a plurality of laterally extending fluid delivery tubes.

[0056] FIG. 42 is an isometric view of the assembly of FIG. 40 showing a plurality of bolts insertable into mating bolt posts for coupling the construction panels together.

[0057] FIG. 43 is an isometric view of the assembly of FIG. 42 with the bolts fully inserted.

[0058] FIG. 44 is an isometric view of the assembly of FIG. 40 showing a plurality of laterally extending fluid delivery tubes.

[0059] FIG. 45 is an isometric view of the assembly of FIG. 40 with longitudinally extending fluid delivery tubes.

[0060] FIG. 46 is an isometric view of an assembly comprising two mating construction panels overlapping by half lengthwise.

[0061] FIG. 47 is a view of an assembly comprising two mating construction panels overlapping diagonally by quarters.

[0062] FIG. 48 is an isometric view of an assembly comprising two mating construction panels overlapping by half sidewise.

[0063] FIG. 49 is an isometric view of an assembly comprising four bottom panels aligned adjacent one another in a 2x2 pattern interconnected by a single centrally disposed overlapping top panel.

[0064] FIG. 50 is a perspective view of an assembly comprising four bottom panels interconnected by four overlapping top panels, the top and bottom panels being offset by half a panel in both longitudinal and lateral directions.

#### DESCRIPTION

[0065] Throughout the following description, specific details are set forth in order to provide a more thorough understanding of the invention. However, the invention may be practiced without these particulars. In other instances, well known elements have not been shown or described in detail to avoid unnecessarily obscuring the invention. Accordingly, the specification and drawings are to be regarded in an illustrative, rather than a restrictive, sense.

[0066] This application relates to a multi-purpose construction panel 10. In the illustrated embodiment panel 10 is generally rectangular in shape. As shown in FIGS. 1 and 2, each panel 10 may be matingly engaged with another panel 10 to form an assembly 12. As shown in FIGS. 3-9, and as described in further detail below, a plurality of panels 10 may be aligned in a desired configuration and releasably coupled together to form assemblies 12 of different sizes and shapes.

[0067] Each panel 10 has a first side 14 and a second side 16. As shown in FIGS. 11 and 18, for example, first side 14 may comprise a planar deck surface 18 interrupted by a plurality of channels 20. Optionally, a plurality of small apertures 22, which extend between sides 14, 16, may be spaced within channels 20. The orientation of the channels 20 may be arranged to form a decorative pattern on first side 14. For example, channels 20 may subdivide deck surface 18 into a plurality of quadrilateral or triangular shaped deck segments. In alternative embodiments, side 14 may consist of a flat continuous sheet or other shapes or patterns could be substituted.

[0068] Panel second side 16 is subdivided into a plurality of compartments 24 by wall partitions 26, as shown in FIGS. 12, 17 and 19 for example. In the illustrated embodiments, compartments 24 are square or rectangular in shape. A plurality of cylindrical female sleeves 28 and male sleeves 30 are disposed within compartments 24. In the illustrated embodiment male sleeves 30 have a smaller diameter and larger height than female sleeves 28. More particularly, sleeves 30 project from compartments 24 to a greater extent than sleeves 28. When a pair of panels 10 are coupled together as shown in FIG. 2, the second sides of the respective panels 10 matingly engage such that each male sleeve 30 on one panel 10 is received within a corresponding female sleeve 28 on the other panel 10, and vice versa.

[0069] As best shown in FIGS. 12, 17 and 19, each compartment 24 may be further subdivided by wall partitions 32 into subcompartments 34. In the illustrated embodiment each compartment 24 is divided into 4 subcompartments 34. Each

wall partition 32 is connected to and structurally supports a sleeve 28, 30. A small cylindrical guide tube 36 may be disposed within each subcompartment 34. Each tube 36 may be connected to a corresponding sleeve 28, 30 by means of a flange 38. As described further below, tubes 36 may function as guides for receiving fasteners used to couple mating panels 10 together. As described below, the fasteners (not shown), are insertable into tubes 36 through apertures 22 which are aligned therewith.

[0070] The bottom or innermost surface 40 of panel second side 16 is generally flat. However, as best shown in FIGS. 17 and 19, surface 40 may comprise elongated ribs 42 which define the channels 20 of panel first side 14, as described above.

[0071] As shown, for example, in FIG. 15, some wall partitions 26 and 32 comprise linearly aligned notches 44 formed in edge portions thereof. In the illustrated embodiment, each notch 44 has a semi-circular or quarter-circular profile. As shown best in the end elevational views of FIGS. 13(a), (b) and 21(a), (b), wall partitions 26 and 32 having notches 44 with a quarter-circular profile may be located at the edges of panel 10 (i.e. where a panel 10 may be arranged to abut another panel 10). When a mating pair of panels 10 are coupled together to form an assembly 12 with the second side 16 of each panel facing inwardly, the notches 44 of each panel 10 are aligned and together define a cylindrical conduit 46 extending through the interior of assembly 12 (FIG. 2). Likewise, when four or more panels 10 are grouped together to form larger structures, conduits 46 may be defined at the joiner between adjacent pairs of assemblies (FIGS. 10(a) and 10(b)). As shown in FIG. 10(a), each conduit 46 may receive a fluid delivery tube 48, for example for circulating anti-freeze, heated air or other fluid through each assembly 12. Other filaments may also be disposed in conduits 46, such as cables for use in securing a large number of assemblies 12 together. Optionally, as shown in FIG. 10(b), tubes 48 or other filaments may be deployed in each assembly 12 in a transverse rather than longitudinal direction (that is, tubes 48 may extend in a direction perpendicular to the direction shown in FIG. 10(a)).

[0072] A plurality of construction panels 10 may be conveniently coupled together to form assemblies 12 having many different possible shapes and sizes. As shown in FIGS. 3-9, multiple panels 10 forming a base portion may first be aligned adjacent one another, each with their first side 14 facing downwardly on a support surface and their second side 16 facing upwardly. A plurality of mating panels 10 forming a top portion, each with their second side facing downwardly and their first side facing upwardly, may then be placed on the aligned base panels 10. As shown in FIGS. 3-6, each top panel 10 may be positioned so that it overlaps multiple base panels 10 to bind the base panels 10 together. Alternatively, each top panel 10 may be positioned so that it is aligned with only a single corresponding base panel 10, as shown in FIGS. 2, 10(a), 10(b) and 15.

[0073] As will be appreciated by a person skilled in the art, although the terms "base" and "top" have been used in the example above, assembly 12 may be configured in many different orientations. For example, since each panel 10 of assembly 12 is identical in this embodiment, and hence assembly 12 is symmetrical, assembly 12 may be flipped 180 degrees so that the "top" panels form part of the base and vice

versa. Further, assemblies 12 may be oriented vertically, for example as part of a wall structure, or in other non-horizontal orientations.

[0074] Once panels 10 have been assembled as desired to form assembly 12, panels 10 may be secured together with fasteners. For example, bolts (not shown) may be inserted through selected apertures 22 on one side of assembly 12 and into tubes 36. Once they are fully inserted, bolts may be secured, such as with nuts, on the opposite side of assembly 12.

[0075] In some applications it may be desirable that assembly 12 be fluid-impervious. For example, in chemical warehouses and the like it may be important that flooring be impervious to fluid chemicals to prevent soil and groundwater contamination. In such applications, grooves 20 on panel first surfaces 14 may be filled with caulking or other sealants after panels 10 have been fastened together. In other embodiments, panels 10 may be manufactured with no apertures 22 or with only a small number of apertures 22 necessary to secure panels 10 together. This would avoid the need to seal unfilled apertures 22.

[0076] In other applications, it may be important that a large number of apertures 22 remain open after assembly 12 is assembled and deployed. For example, assembly 12 may be used in applications, such as temporary walkways, where it is desirable to avoid collection of water on the surface thereof. In such applications water can be collected within channels 20 and drain through tubes 36 into the ground or other support surface underlying assembly 12. Apertures 22 also enable any water or water vapour within the interior of assembly 12 to escape to the surrounding environment. This may be important in northern climates having frequent freeze/thaw weather cycles.

[0077] Construction panels 10 may be formed from molded plastic or other light-weight materials in one embodiment of the invention. By way of non-limiting example, each panel 10 may be 32"x48" in size have a thickness of approximately 2". In this example, each compartment 24 is approximately 8"x8" in size and each longitudinally extending conduit 46 (FIG. 10(a)) is approximately 16" apart. A plastic panel 10 having the above dimensions weighs on the order of about 20 pounds and may therefore be easily lifted and carried by a single person for ease of installation. This enables convenient assembly or disassembly of panels 10 by ordinary consumers without the need for cranes or other heavy lifting machinery.

[0078] Construction panels 10 may be used to form assemblies 12 useful in a wide variety of applications. For example, assemblies 12 may be used in flooring, roofing and wall construction applications in both indoor and outdoor environments. By way of non-limiting examples, assemblies 12 may be used in walkways, roadways, parking lots, driveways, decking and roofing. In some applications, assemblies 12 may be mounted on top of existing structures, such as decking joists or beams, or may be covered by other materials, such as roofing materials. Since panels 10 are lightweight and easy to handle, and relatively inexpensive to manufacture and transport, they will be useful in many consumer applications. Other potential consumer and industrial applications for construction panels and the like are described in the applicant's U.S. Pat. No. 7,914,228 issued 29 Mar. 2011 entitled MULTI-PURPOSE CONSTRUCTION MODULE which is hereby incorporated by reference in its entirety.

[0079] As described above, assemblies 12 may be deployed in applications where it is desirable to regulate the tempera-

ture or other physical characteristics thereof. For example, heated assemblies **12** may be used as temporary driveway covers in winter months to prevent snow and ice accumulation. The temperature of assemblies **12** may be regulated by circulating fluids in a flow path through the interior of each assembly **12**. For example, as shown schematically in FIG. **10**, in one embodiment of the invention a heat-regulating or heat exchanging fluid may be circulated through tubing **48** deployed within conduits **46**. As used in this patent application, the term "fluids" includes both liquids and gases. For example, the fluid may be water heated by a boiler (not shown) in fluid communication with tubing **48**. In another embodiment of the invention, the fluid may be anti-freeze. In yet another embodiment, gases could be circulated within conduits **46**, such as heated air. The boiler may include a fluid pump or, alternatively, a pump may be installed at another location in the flow path. As is well known in the prior art, the fluid pump may include a timer or other controller to operate only during selected intervals rather than continuously.

[0080] By way of further example, assemblies **12** may be connected to form panels suitable for use as heated flooring, roofing or wall panels. For example, heated flooring, walls or roofing comprising construction panels **10** could be used in barns, stables, greenhouses, storage sheds or other temporary structures where it is important to control indoor temperature or avoid snowfall or ice accumulation. As indicated above, other materials could be placed over assemblies **12** such as dirt, mulch, bedding, rubber matting, styrofoam or other roofing materials, depending upon the particular application.

[0081] As indicated above, assemblies **12** could be temporarily installed in outdoor parking lots, driveways, roadways and the like to melt snow during winter months in northern climates. Assemblies **12** could similarly be used on roofing to reduce or prevent snow accumulation. Assemblies **12** could be configured so that they are heated only during particular climatic conditions or during particular times of day. At the end of the winter season the panels **12** could be quickly and easily disassembled and removed if desired.

[0082] Depending upon the application and range of operating temperatures, the distance between conduits **46** could be adjusted. For example, in very cold conditions the number of conduits **46** carrying heated water in tubes **48** could be increased to reduce the distance between adjacent conduits and ensure that the entire assembly **12** is evenly heated. As will be appreciated by a person skilled in the art, in alternative embodiments of the invention the flow path of conduits **48** could also be varied (e.g. by using non-linear flow paths) to achieve substantially even heating or to suit particular applications.

[0083] As will be appreciated by a person skilled in the art, construction panels **10** may be formed in many different shapes and sizes. For example, in addition to rectangular shapes, panels **10** could be constructed in hexagonal, pentagonal or other geometric shapes or combinations thereof.

[0084] A further embodiment of the invention is in FIGS. **22-26**. In this embodiment a tube **36a** may be located in each sleeve **28** and **30**. As described above, panels **10** may be coupled together to form an assembly **12** with each male sleeve **30** inserted into a corresponding female sleeve **28**. Panels **10** may then be secured together with fasteners such as bolts inserted through selected apertures **22** on one side of assembly **12** and into tubes **36a** (instead of, or in addition to, tubes **36**). Once they are fully inserted, bolts may be secured, such as with nuts, on the opposite side of assembly **12**. Each

panel may also include notches **22a** surrounding an aperture **22** on first side **14** to accommodate a bolt **5** head, nut or washer. This ensures that end portions of the fastener will be flush or recessed relative to deck **18**.

[0085] In the embodiment of FIGS. **22-26** additional flanges **38** may be provided for structurally supporting tubes **36** and **36a**. For example, as shown best in FIG. **26**, each tube **36**, **36a** may be supported by four separate flanges **38**.

[0086] A further embodiment of the invention is shown in FIGS. **27-50**. As in other embodiments, panel **10** is generally rectangular in shape and has a first side **14** and a second side **16**. As in other embodiments, first side **14** may comprise a generally planar deck surface **18** (FIG. **30**). As shown for example in FIGS. **27**, **27A**, **33** and **35**, second side **16** includes a plurality of compartments **24** defined by wall partitions **26** which project from a flat bottom or innermost surface **40**. The outermost wall partitions **26** form the side and endwalls at the perimeter of panel **10**. As shown best in FIG. **35**, sleeves **28**, **30** and partitions **32** may have radiused corners **50** where they are connected to surface **40**.

[0087] In the illustrated embodiments, compartments **24** are square or rectangular in shape. A plurality of cylindrical female sleeves **28** and male sleeves **30** are disposed within compartments **24** in an alternating array and project from surface **40**. As in other embodiments, male sleeves **30** have a smaller diameter and larger height than female sleeves **28**. In some embodiments male sleeves **30** may be tapered, as best shown in FIG. **35**. When a pair of panels **10** are coupled together to form an assembly **12**, as shown for example in FIG. **31**, the second sides of the respective panels **10** matingly engage such that each male sleeve **30** on one panel **10** is received within a corresponding female sleeve **28** on the other panel **10**, and vice versa.

[0088] As in other embodiments, each compartment **24** may be further subdivided by wall partitions **32** into subcompartments **34** (FIG. **33**). Each wall partition **32** structurally supports a sleeve **28**, **30** and includes a radiused portion **52** distal from the sleeve **28**, **30** adjacent a wall partition **26**. In the illustrated embodiment, wall partitions **32** may extend longitudinally, laterally and/or diagonally to provide structural support for sleeves **28**, **30** disposed within compartments **24**. As will be apparent to a person skilled in the art, other configurations of wall partitions **26** and **32** are possible. As shown best in FIGS. **27** and **35**, adjacent radiused portions **52** of partitions **32** together define channels **45** having a semi-circular profile extending above wall partitions **26** in both longitudinal and lateral (i.e. transverse) directions. When a pair of panels **10** are coupled together to form an assembly **12**, channels **45** from mating panels **10** are aligned to together form cylindrical conduits **46** extending through the interior of the assembly **12** (FIGS. **31-32**). Since conduits **46** extend above each wall partition **26** in this embodiment, the total number of conduits **46** is greater than in the embodiments of FIGS. **10(a)** and **10(b)**.

[0089] In the embodiment of FIGS. **27-50** an internally threaded bolt post **54** is positioned within some or all of sleeves **28**, **30**. As shown best in FIGS. **36**, **42** and **43**, when a pair of panels **10** is coupled together to form an assembly **12** the threaded bolt posts **54** disposed within mating sleeves **28**, **30** are aligned. Bolts **56** can be inserted into the threaded bolt posts **54** from either direction to securely couple panels **10** together. Each bolt post **54** includes a countersunk end portion **58** to accommodate the end of the bolt (FIG. **36**). As shown in FIGS. **42** and **43**, in one embodiment bolts **56** may

be inserted at selected locations on assembly **12** rather than in each sleeve **28**, **30**. Apertures **60** may extend between sides **14**, **16** at selected locations to receive bolts **56** (FIG. **42**).

**[0090]** In an alternative embodiment of the invention bolt posts **54** may not be internally threaded. In this case bolts **56** or other fasteners may be inserted through bolt posts **54** and held in place with a nut, similar to the embodiment described above where fasteners are insertable into tubes **36** and/or **36a**.

**[0091]** As in other embodiments, conduits **46** are provided for receiving fluid delivery tubes **48**. As explained above, fluid delivery tubes may be used, for example, for circulating anti-freeze, heated air, heated liquid or other fluids through assembly **12**. FIG. **41** shows a side elevational view of an assembly **12** with fluid delivery tubes **48** installed within conduits **46**. FIGS. **44** and **45** illustrate an assembly with fluid delivery tubes **48** configured as either laterally extending or longitudinally extending radiant heat sources. Since there are a greater number of conduits **46** in the embodiment of FIGS. **27-50**, this enables an increased density of fluid delivery tubes **48** in comparison to other embodiments, resulting in enhanced heat or cold distribution in radiant heat installations. In use, fluid delivery tubes **48** would typically be installed on a lower panel **10** in channels **45** before an upper panel **10** was aligned and coupled to the lower panel **10** and bolted in place as described above.

**[0092]** The embodiment of FIGS. **27-50** comprises a larger number of compartments **24** and wall partitions **26**, **32** in comparison, for example, to the panels **10** of FIGS. **17** and **24**. Thus each panel **10** can have a more narrow profile than other embodiments of the invention while maintaining sufficient strength for a wide variety of consumer applications. By way of non-limiting example, wall partitions **26** may be spaced 4 inches apart (FIG. **35**) and may be  $\frac{3}{16}$ " in thickness. The length and height of panel **10** may be 48"x32" in this example; the resulting assembly **12** (FIG. **40**) may have an interlocked height of approximately 2-3 inches. Each panel **10** may be formed from molded plastic or other light-weight materials and may be reusable and recyclable. In one embodiment, the total weight of panel **10** may be approximately 20 pounds. Since panel **10** of FIGS. **27-50** has a narrow profile, it may be manufactured more quickly in a conventional plastic mold (e.g. 2½ minutes as compared to 7½ minutes) and at lower cost than other embodiments requiring more plastic.

**[0093]** As in other embodiments of the invention, panels **10** may be coupled together in offset, interlocking patterns to form assemblies **12** comprising two or more panels **10** (FIGS. **46-50**). Thus a first panel **10** may either be aligned directly above an underlying second panel **10** or misaligned with an underlying second panel **10**. For example, as shown in FIG. **49**, one upper panel **10** may overlap four different lower panels **10** to couple the lower panels **10** together. Panels **10** may be cut to cover non-overlapping portions after full-size panels **10** are coupled together (e.g. the non-overlapping portions shown in FIG. **50**).

**[0094]** As will be apparent to those skilled in the art in the light of the foregoing disclosure, many alterations and modifications are possible in the practice of this invention without departing from the spirit or scope thereof. Accordingly, the scope of the invention is to be construed in accordance with the substance defined by the following claims.

What is claimed is:

1. A construction panel having a first side and a second side, wherein said first side comprises a substantially planar deck and said second side comprises:

- (a) a plurality of first wall elements defining a plurality of compartments therebetween; and
- (b) a plurality of sleeves each located in one of said compartments.

2. The panel as defined in claim 1, wherein said deck has a plurality of spaced-apart channels formed therein.

3. The panel as defined in claim 2, wherein said channels subdivide said deck into a plurality of quadrilateral or triangular shaped deck segments.

4. The panel as defined in claim 2, comprising a plurality of spaced-apart apertures extending through said panel between said first and second sides.

5. The panel as defined in claim 4, wherein said apertures are located in said channels.

6. The panel as defined in claim 1, wherein said sleeves comprise a first group of female sleeves having a first height and a second group of male sleeves having a second height exceeding said first height, wherein said male sleeves of one of said panels are sized to fit within said female sleeves of another one of said panels.

7. The panel as defined in claim 6, wherein said sleeves are cylinders each having an open end at a location furthest from said deck.

8. The panel as defined in claim 7, wherein said female sleeves have a diameter exceeding a diameter of said male sleeves.

9. The panel as defined in claim 6, wherein said first wall elements have a height substantially the same as said first height.

10. The panel as defined in claim 6, wherein said female and male sleeves are arranged within said compartments in an alternating array.

11. The panel as defined in claim 10, wherein each of said compartments is further subdivided into a plurality of sub-compartments defined by a plurality of second wall elements, each of said second wall elements extending between one of said first wall elements and one of said sleeves.

12. The panel as defined in claim 11, comprising a plurality of guide tubes, wherein each of said guide tubes is located within one of said subcompartments.

13. The panel as defined in claim 12, comprising a plurality of spaced-apart apertures extending through said panel between said first and second sides, wherein each of said guide tubes is aligned with one of said apertures.

14. The panel as defined in claim 13, wherein each of said guide tubes further comprises a support rib connecting said tube to a corresponding one of said sleeves.

15. A construction assembly comprising at least two construction panels as defined in claim 1 coupled together, wherein said second side of one of said panels releasably engages said second side of another one of said panels.

16. The assembly as defined in claim 15, wherein said assembly comprises a first group of said panels arranged adjacent one another with said first and second sides in alignment and a second group of said panels arranged adjacent one another with said first and second sides in alignment, wherein said second sides of said first group of panels engages said second sides of said second group of panels, wherein at least some of said panels in said second group overlap multiple panels in said first group to connect said multiple panels together.

17. The assembly as defined in claim 15, wherein said sleeves of each of said panels comprise a first group of female sleeves having a first height and a second group of male



sleeves having a second height exceeding said first height, wherein said male sleeves of said one of said panels are sized to fit within said female sleeves of said another one of said panels and vice versa.

**18.** The assembly as defined in claim **17**, wherein, in each of said panels, said female and male sleeves are arranged within said compartments in an alternating array.

**19.** The assembly as defined in claim **18**, wherein, in each of said panels, each of said of said compartments is further subdivided into a plurality of subcompartments defined by a plurality of second wall elements, each of said second wall elements extending between one of said first wall elements and one of said sleeves.

**20.** The assembly as defined in claim **19**, wherein each of said panels comprises a plurality of guide tubes, wherein at least some of said guide tubes are located within a corresponding one of said subcompartments.

**21.** The assembly as defined in claim **20**, wherein said guide tubes of said one of said panels is aligned with said guide tubes of said another one of said panels.

**22.** The assembly as defined in claim **21**, comprising a plurality of spaced-apart apertures extending through each of said panels between said first and second sides thereof, wherein each of said guide tubes is aligned with an aligned pair of said apertures.

**23.** The assembly as defined in claim **22**, wherein at least some of said guide tubes are located within said male and female sleeves.

**24.** The assembly as defined in claim **23**, further comprising support flanges connected to said guide tubes.

**25.** The assembly as defined in claim **23**, further comprising notches surrounding at least some of said apertures on said first side of said panel.

\* \* \* \* \*