



US 20180219459A1

(19) **United States**

(12) **Patent Application Publication**

Chahine et al.

(10) **Pub. No.: US 2018/0219459 A1**

(43) **Pub. Date: Aug. 2, 2018**

(54) **MODULAR STATOR DRIVE UNITS FOR AXIAL FLUX ELECTRIC MACHINES**

H02K 1/14 (2006.01)

H02K 21/24 (2006.01)

(52) **U.S. Cl.**

CPC *H02K 11/33* (2016.01); *H02K 21/24* (2013.01); *H02K 1/14* (2013.01); *H02K 3/18* (2013.01)

(71) Applicant: **Regal Beloit Australia, PTY., Ltd.**, Rowville (AU)

(72) Inventors: **Hani Chahine**, Rowville (AU); **Pamela Lee**, Epping (AU); **Mark Thiele**, Cape Woolamai (AU); **Greg Heins**, Rowville (AU)

(21) Appl. No.: **15/421,048**

(22) Filed: **Jan. 31, 2017**

Publication Classification

(51) **Int. Cl.**

H02K 11/33 (2006.01)

H02K 3/18 (2006.01)

(57) **ABSTRACT**

A stator module pack for an axial flux electric machine includes a housing for attachment to a stator base, a plurality of stator modules attached to the housing, and a drive unit attached to the housing. Each stator module includes a core having at least one winding disposed thereon. The drive unit is electrically connected to at least one stator module. A plurality of stator module packs and a plurality of drive units are coupled to the stator base to form a stator of the axial flux electric machine.

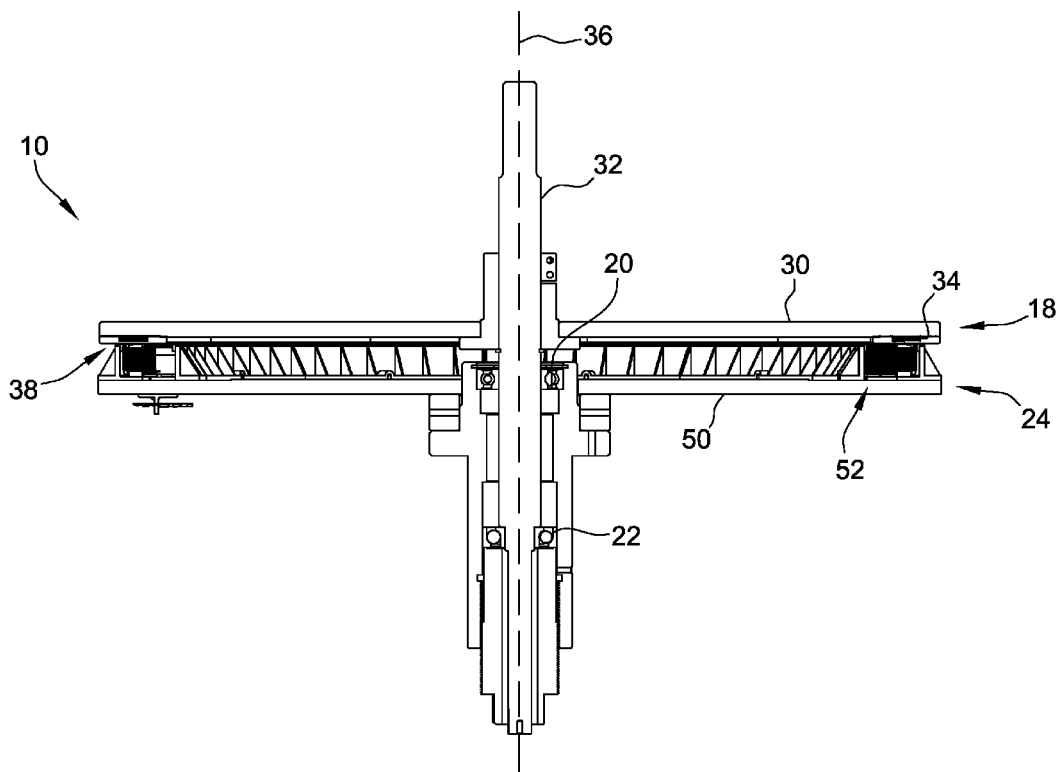

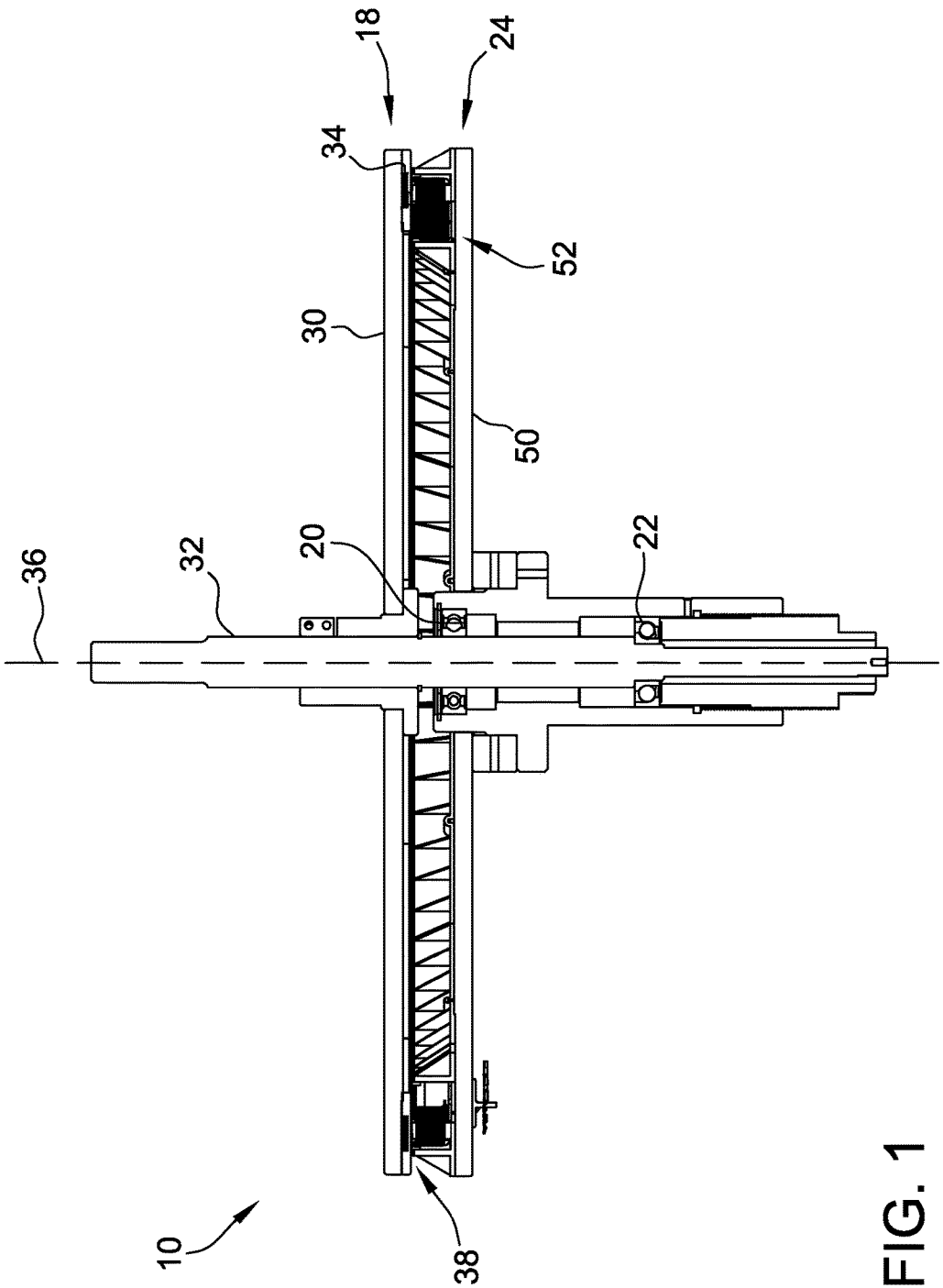

FIG. 1

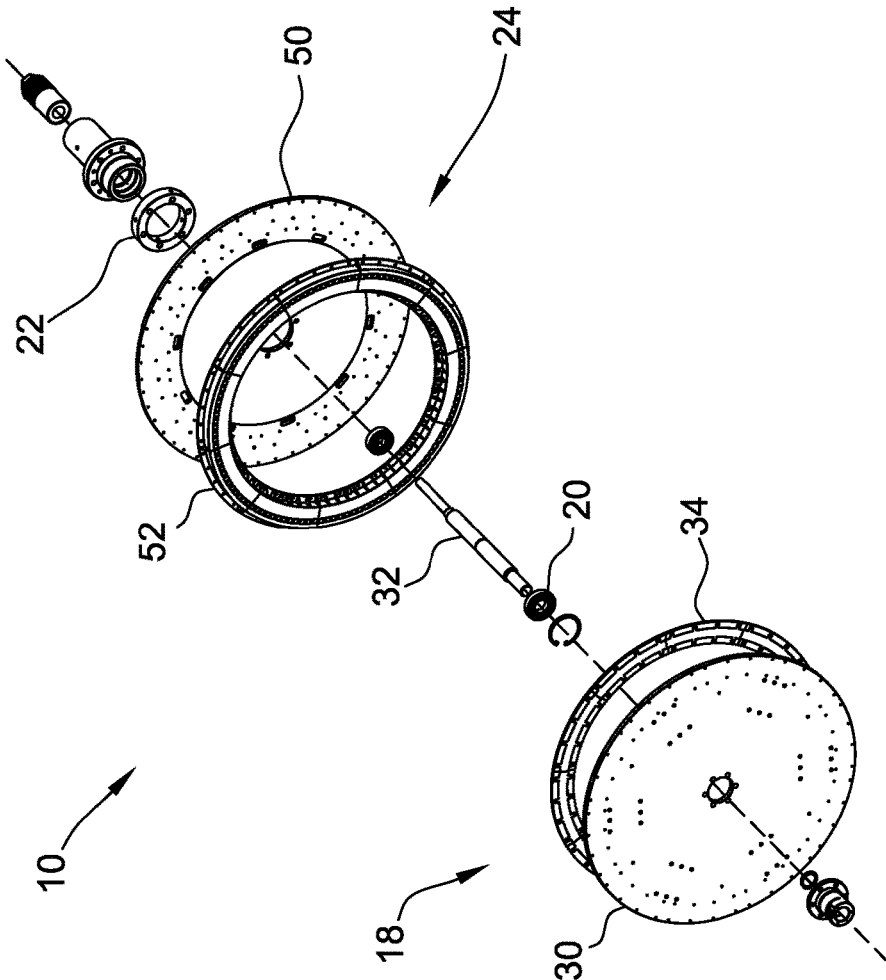

FIG. 2

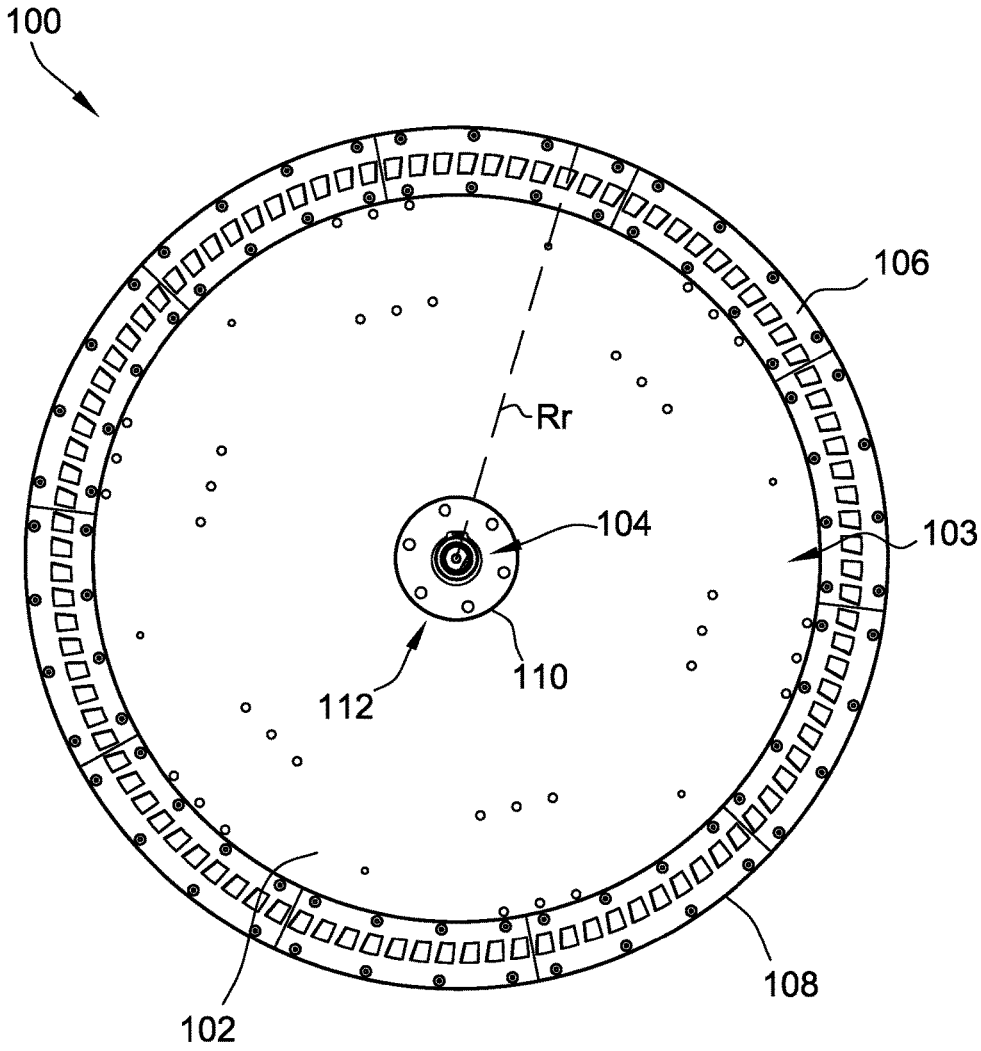

FIG. 3

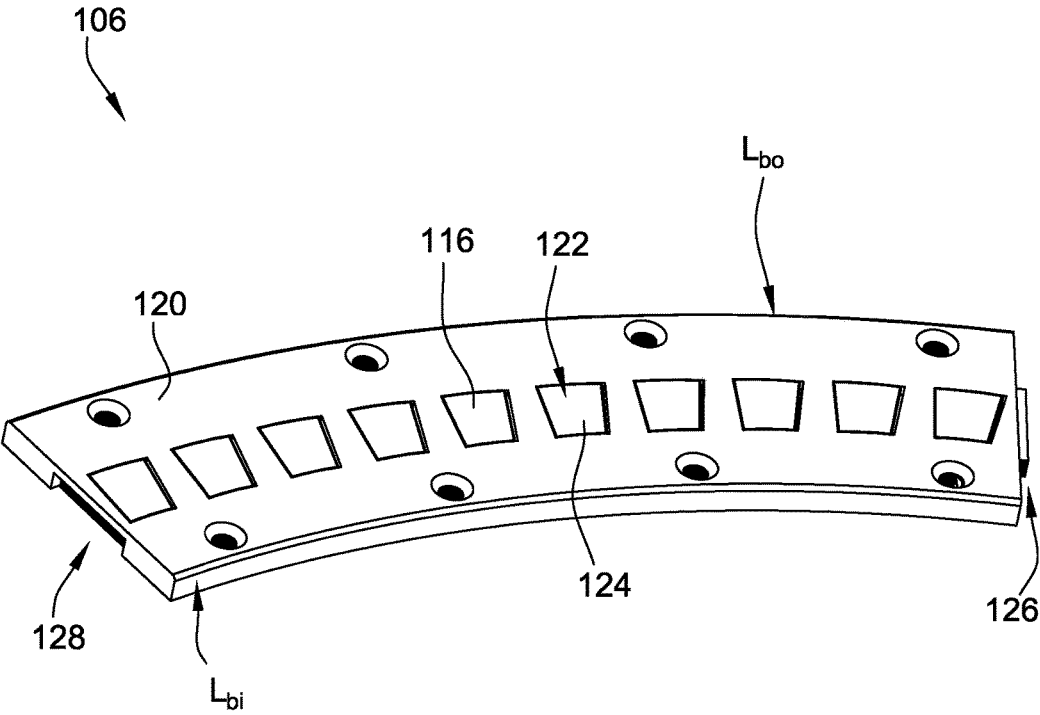

FIG. 4A

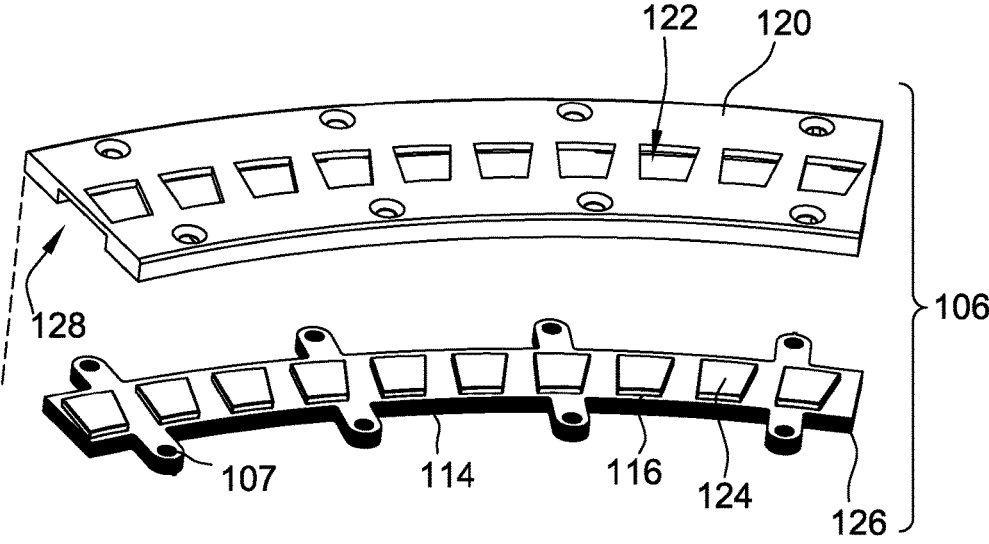
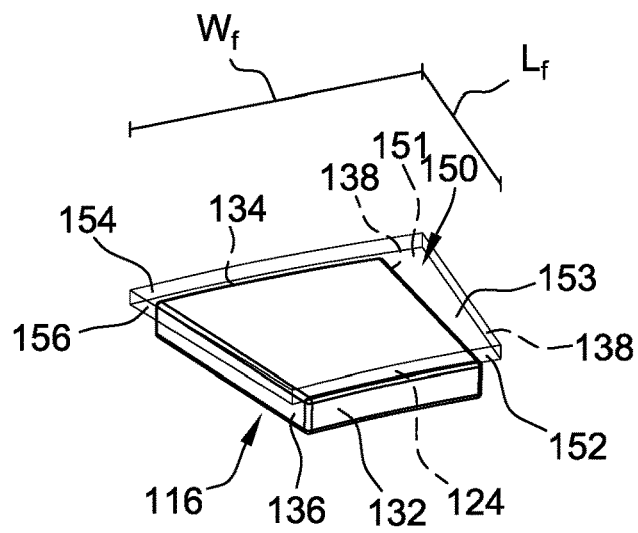
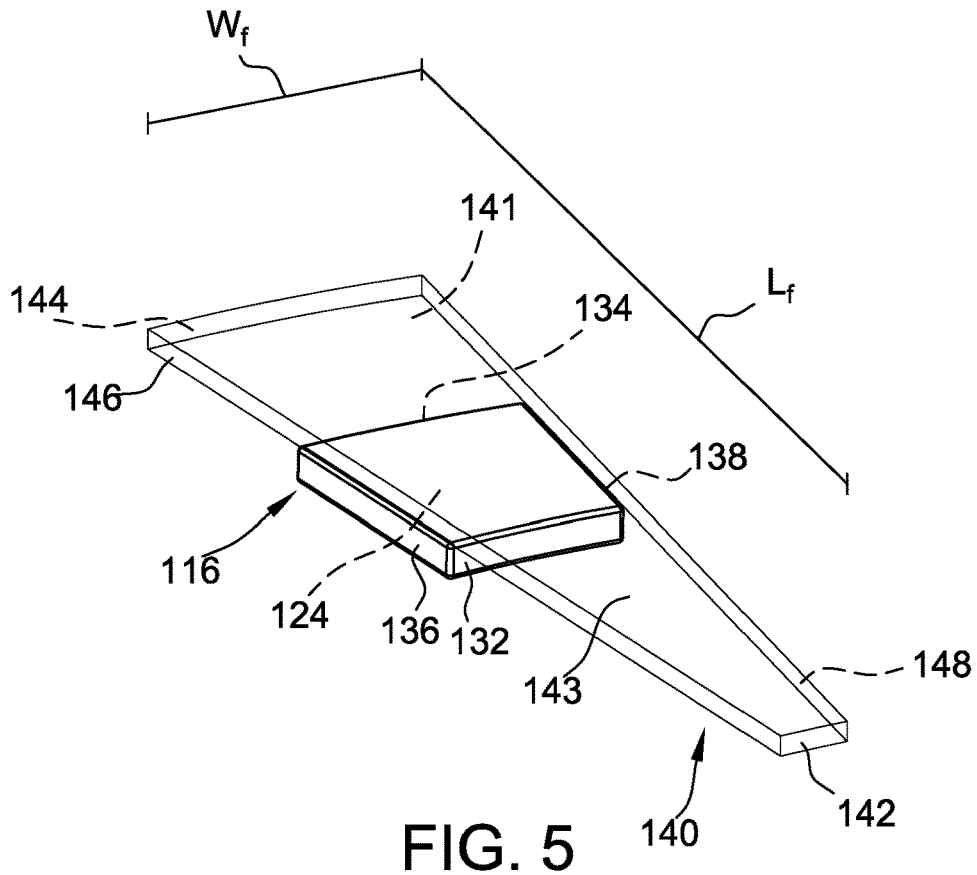

FIG. 4B



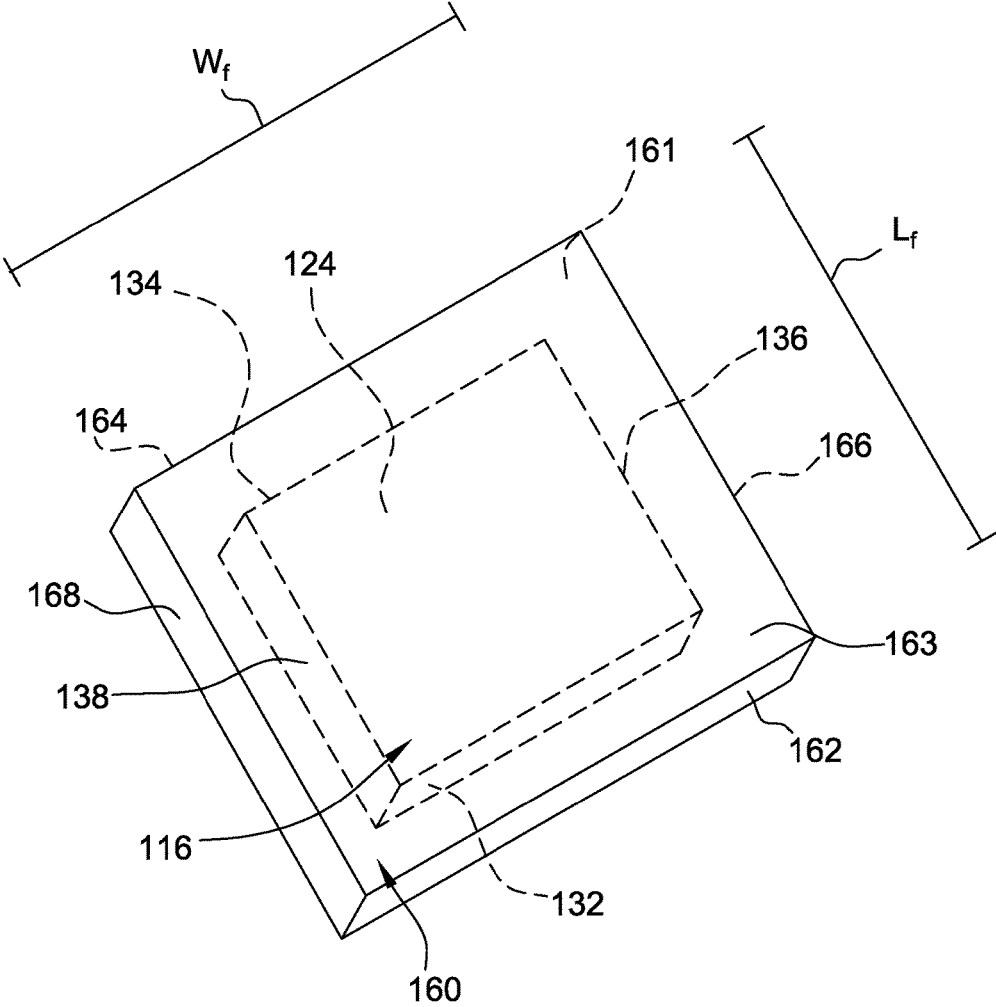

FIG. 7

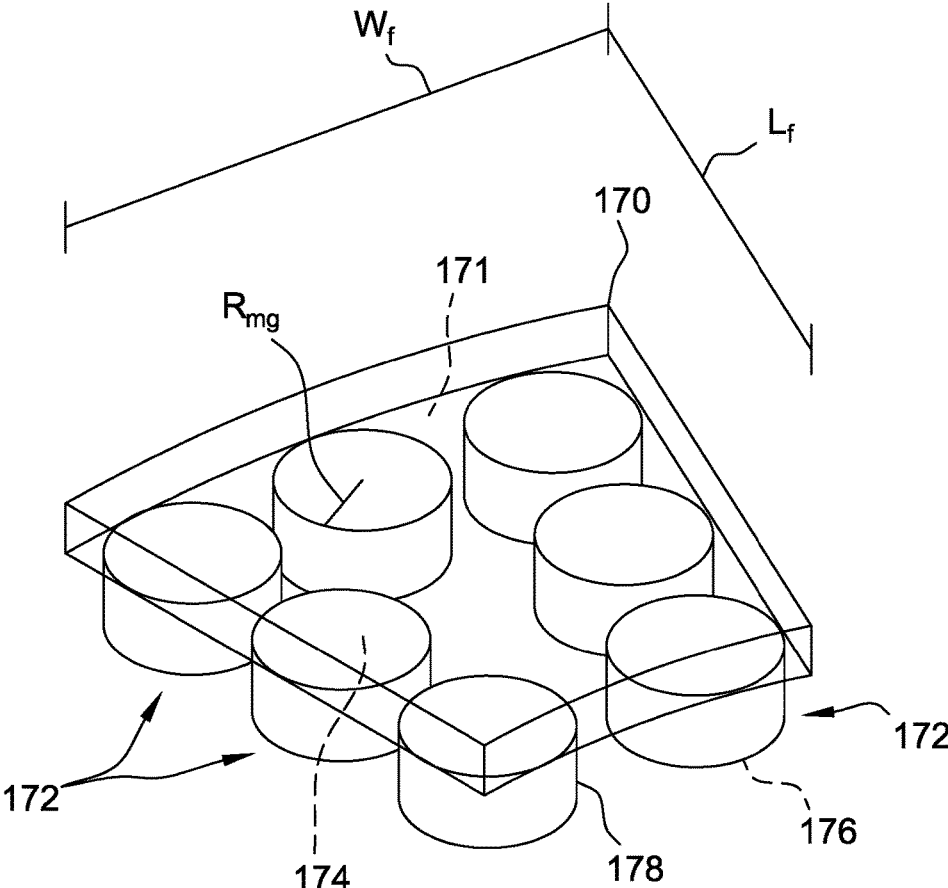

FIG. 8

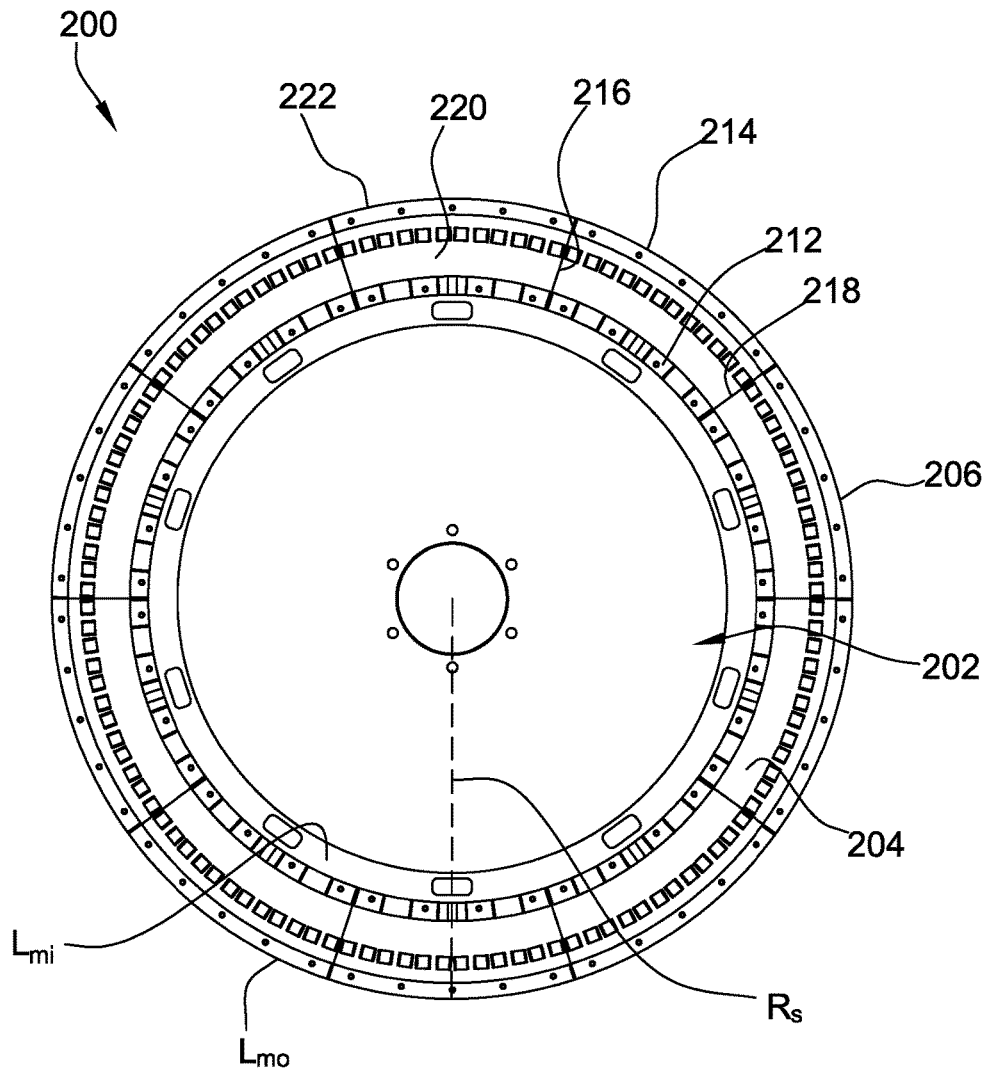

FIG. 9

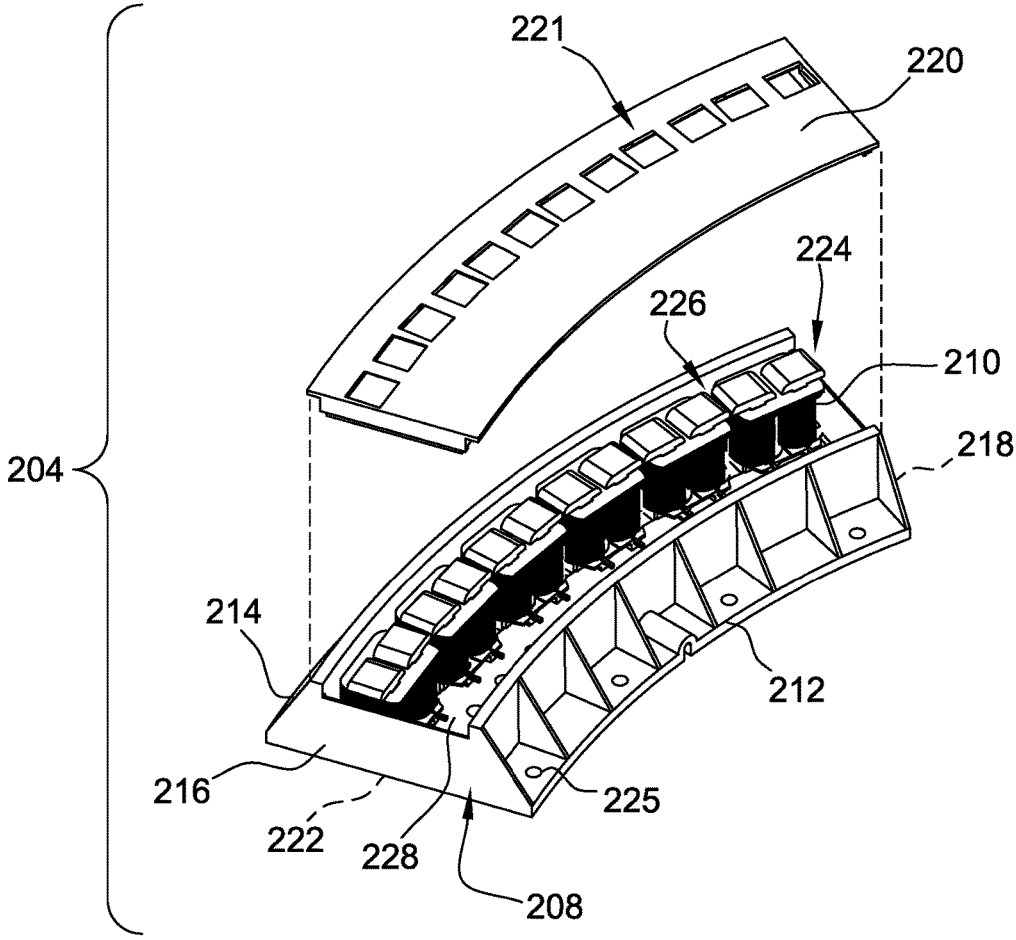

FIG. 10

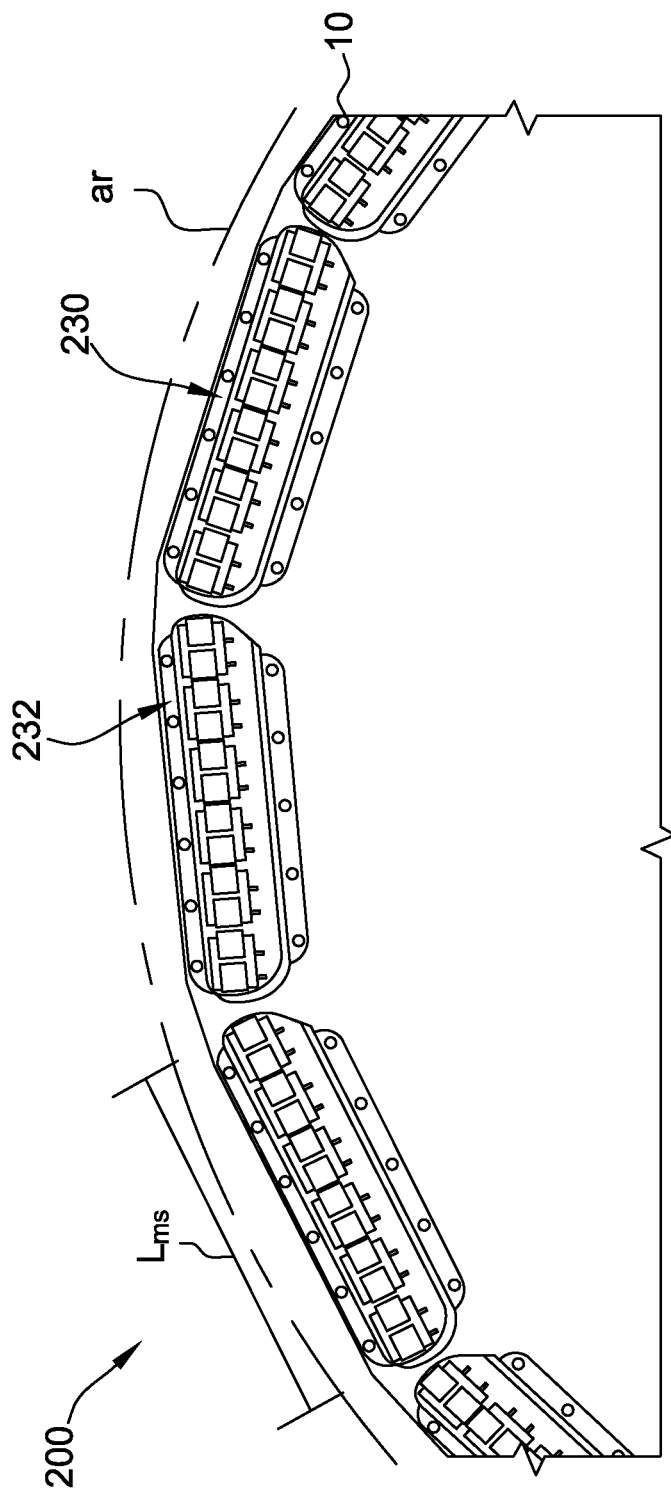

FIG. 11

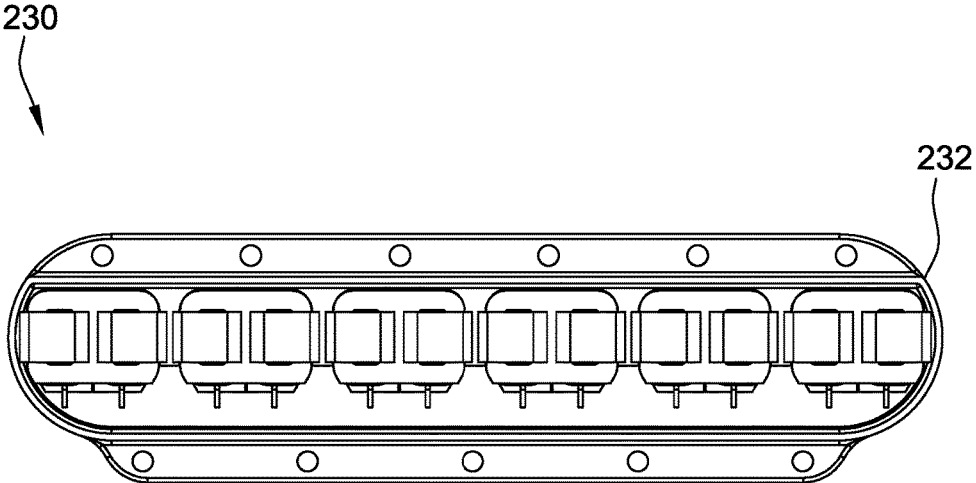

FIG. 12

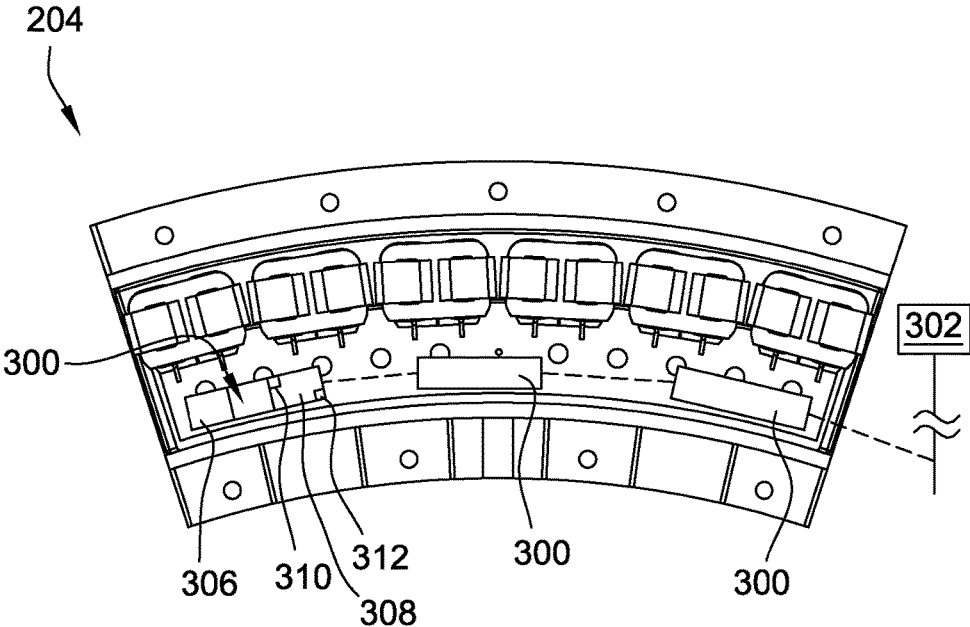

FIG. 13

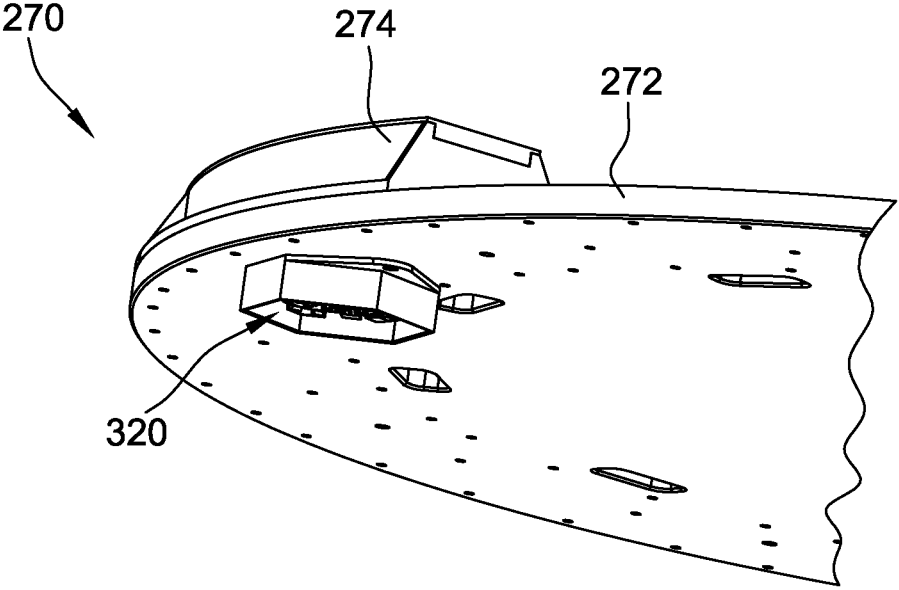

FIG. 14

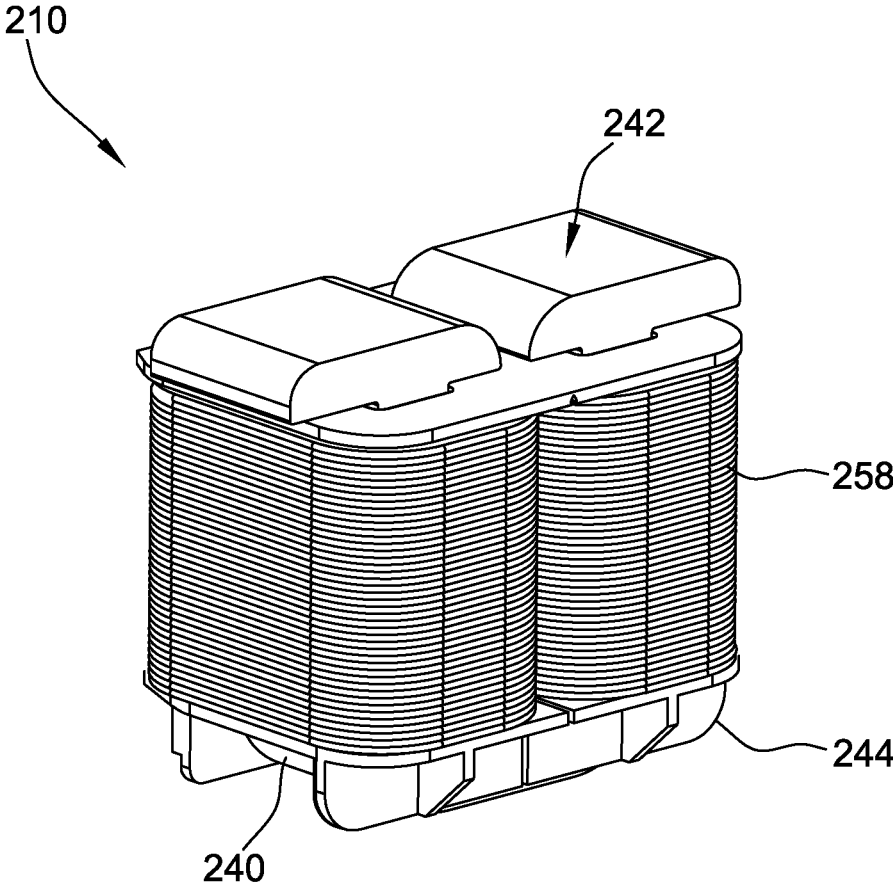

FIG. 15

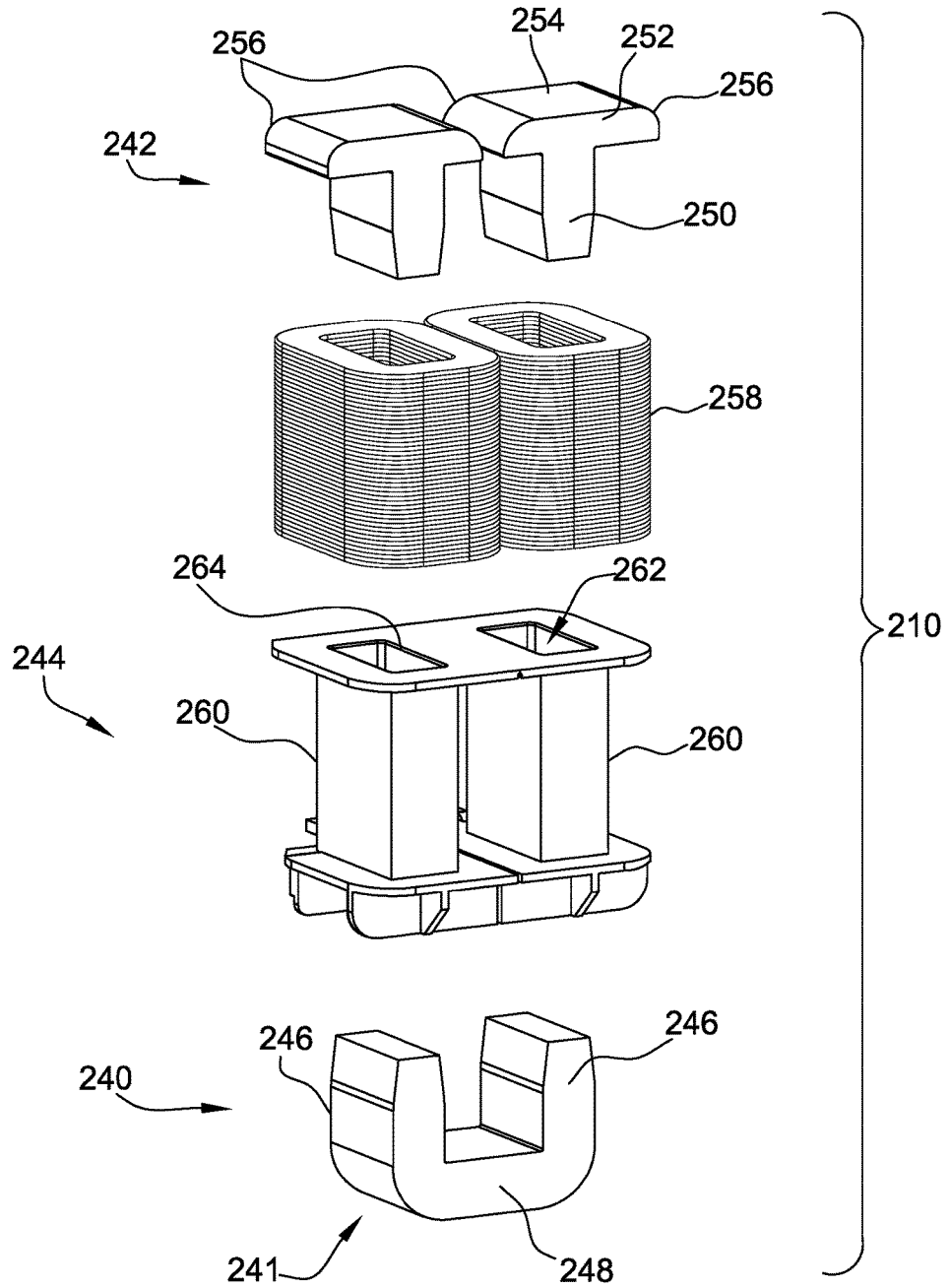

FIG. 16

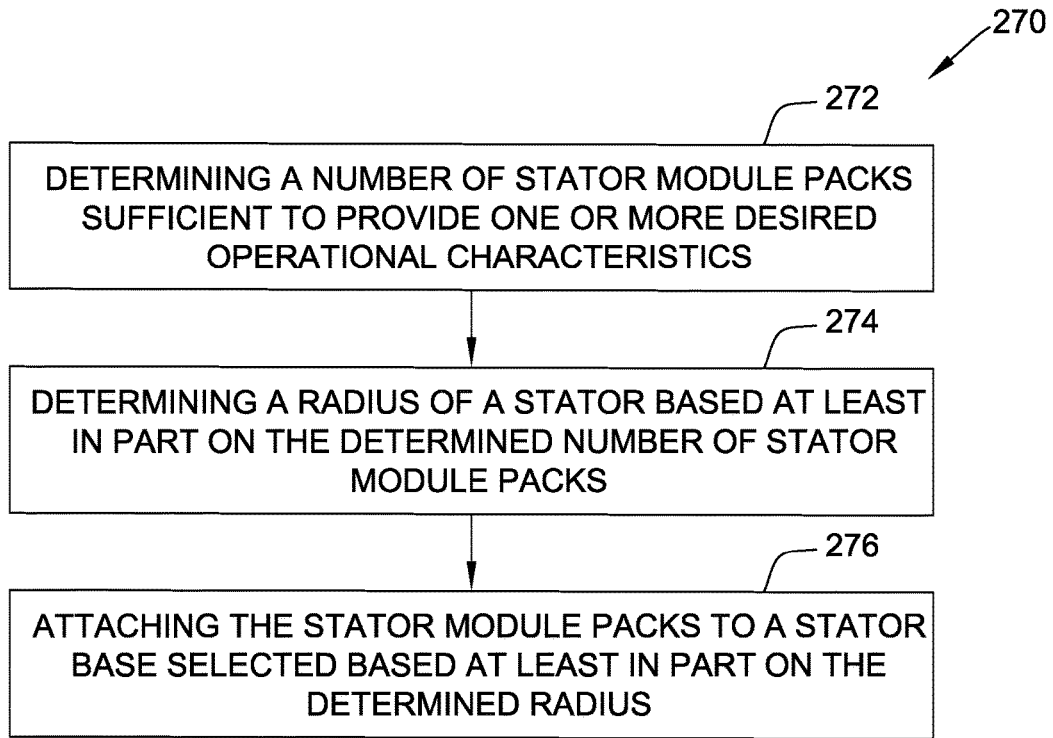

FIG. 17

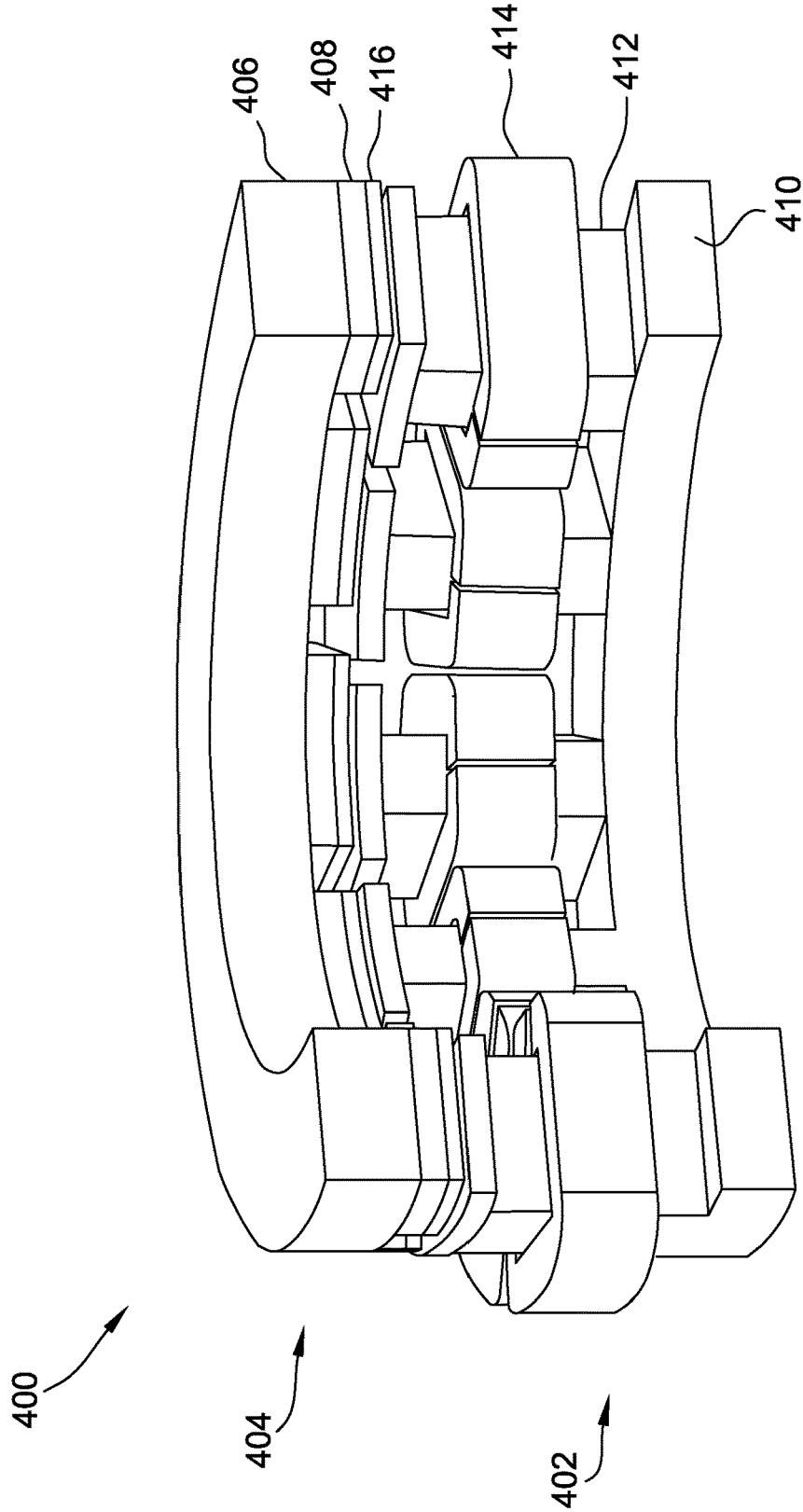

FIG. 18

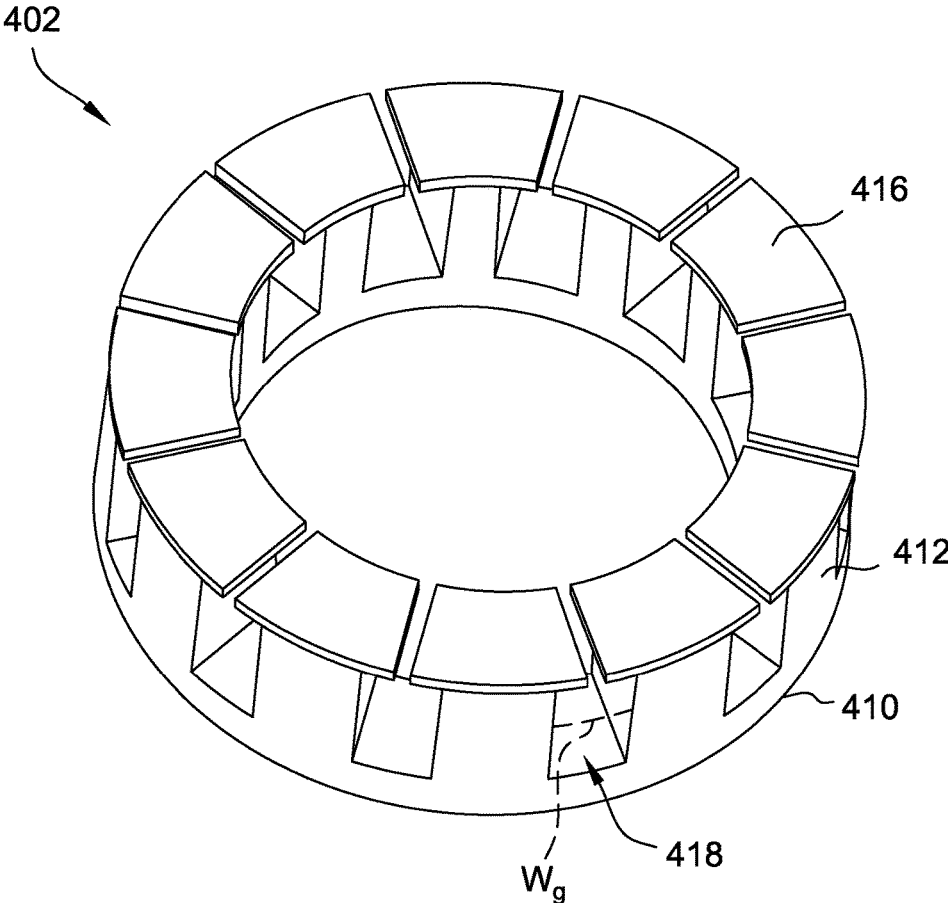

FIG. 19

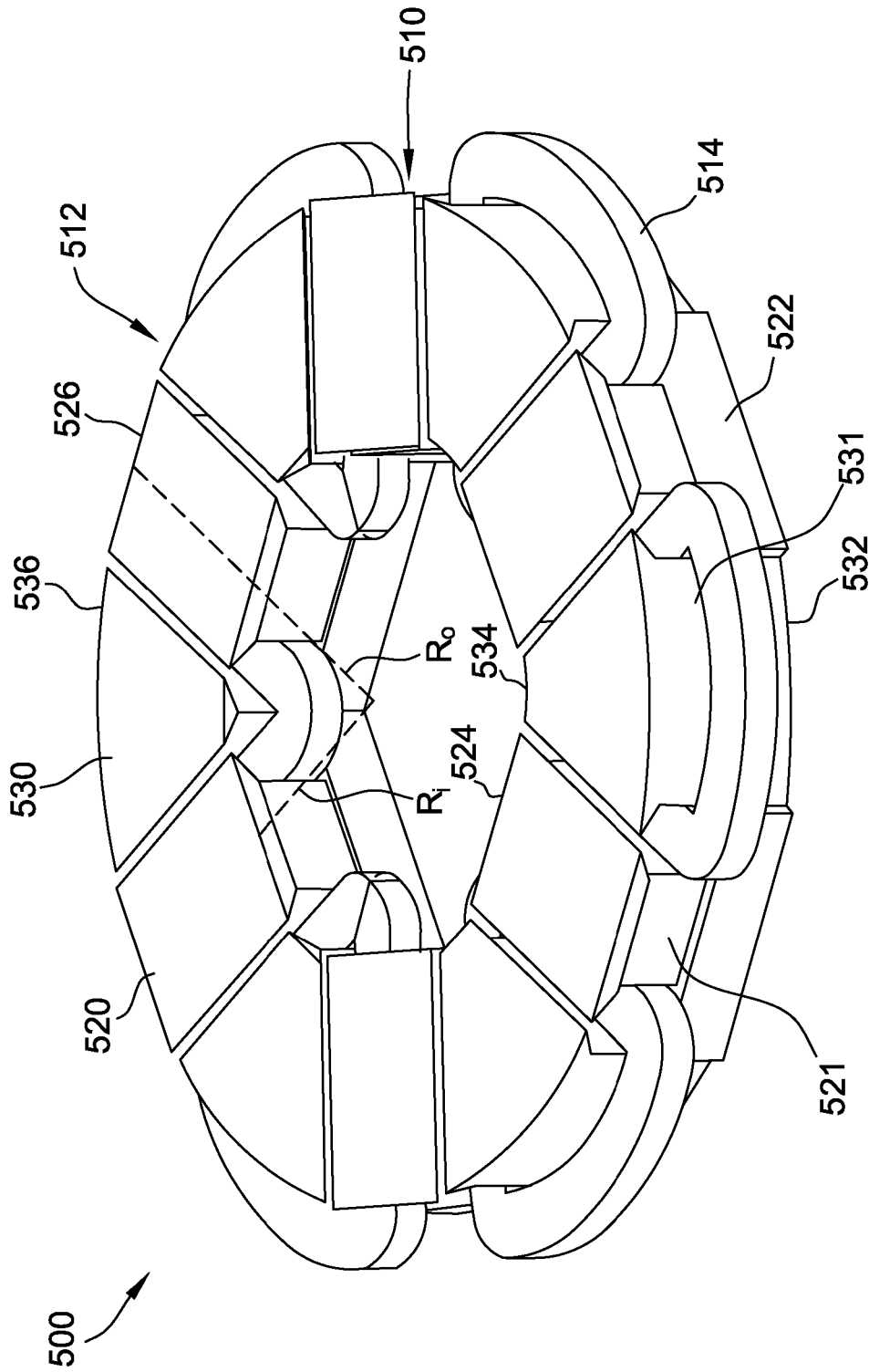

FIG. 20

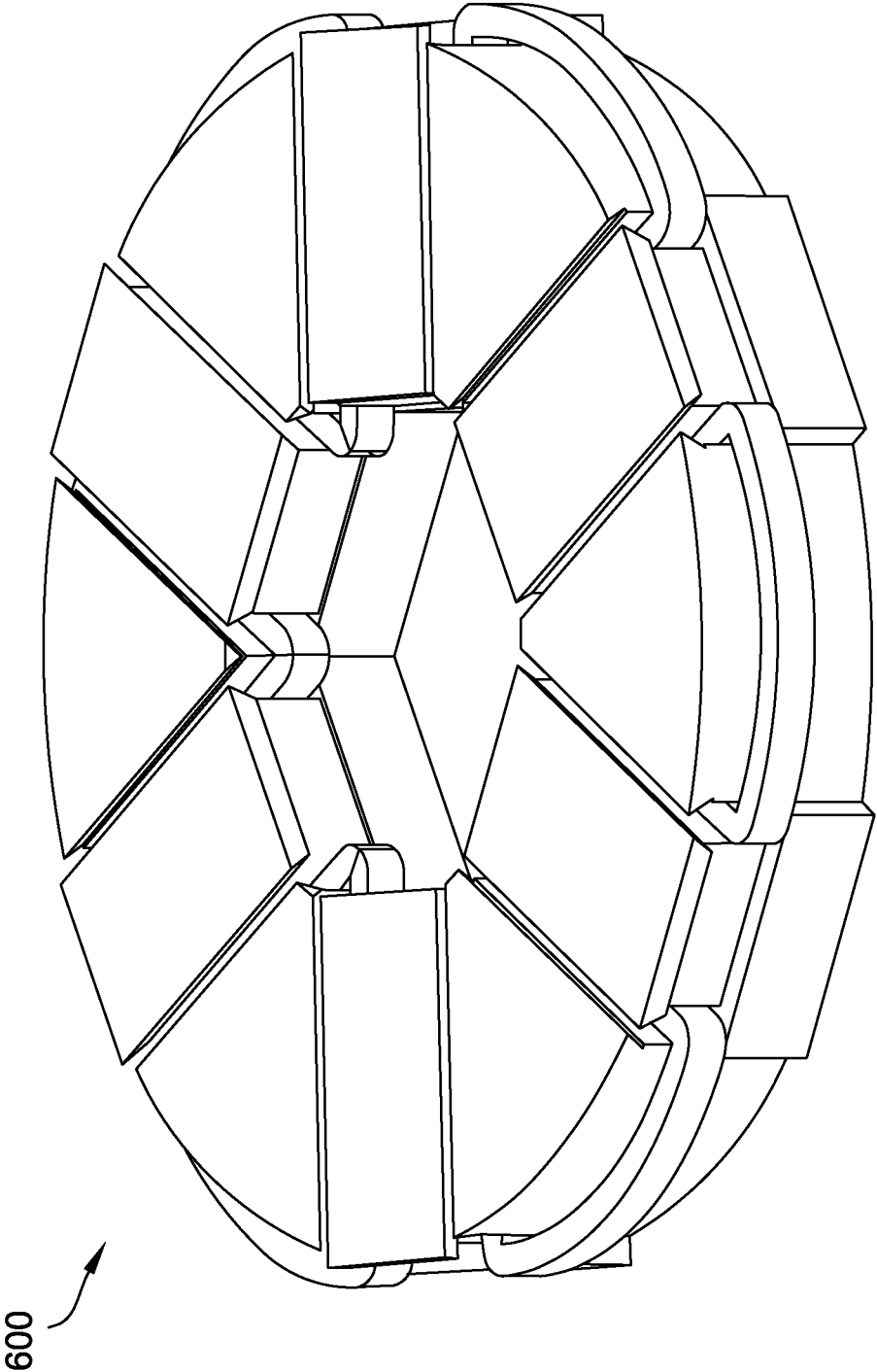

FIG. 21

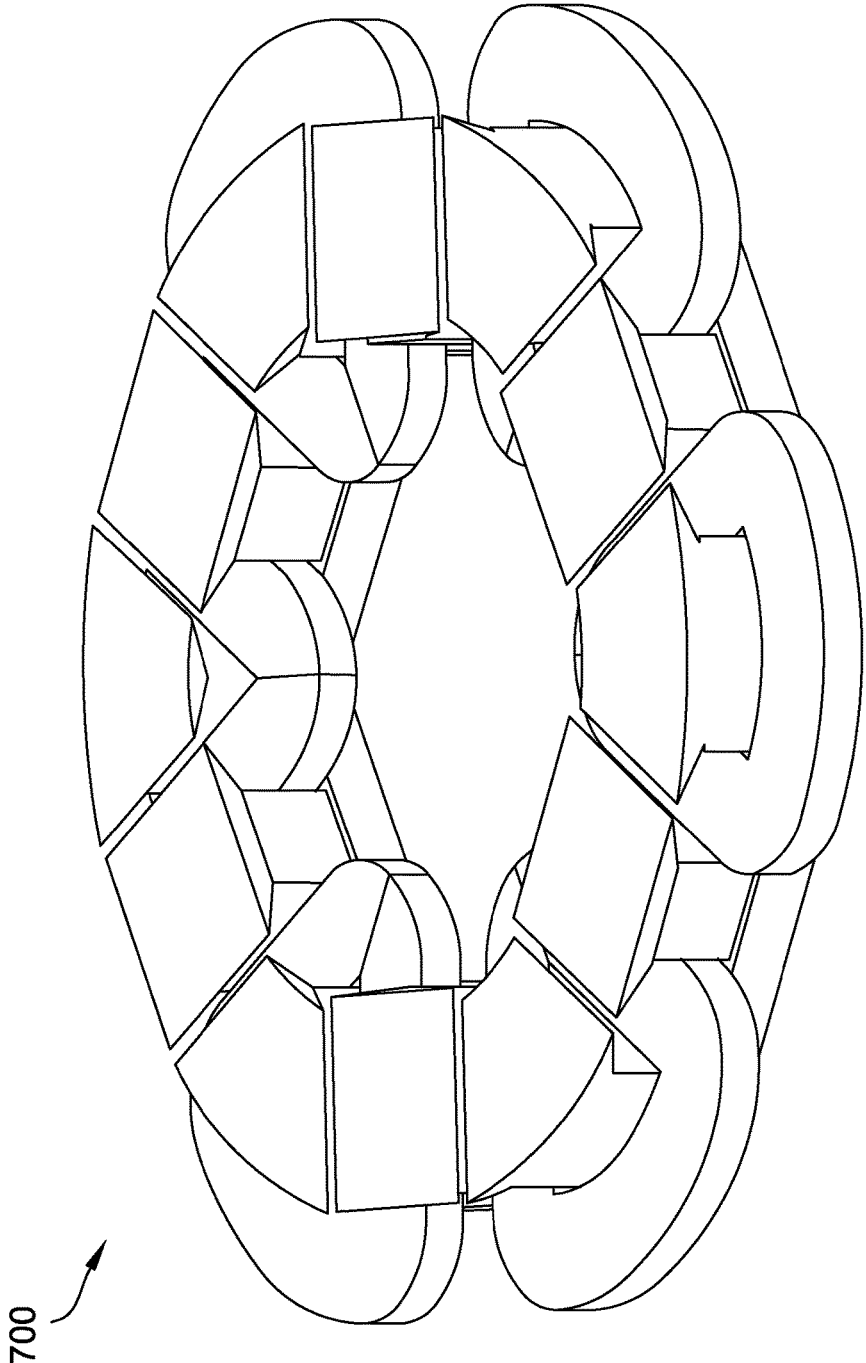

FIG. 22

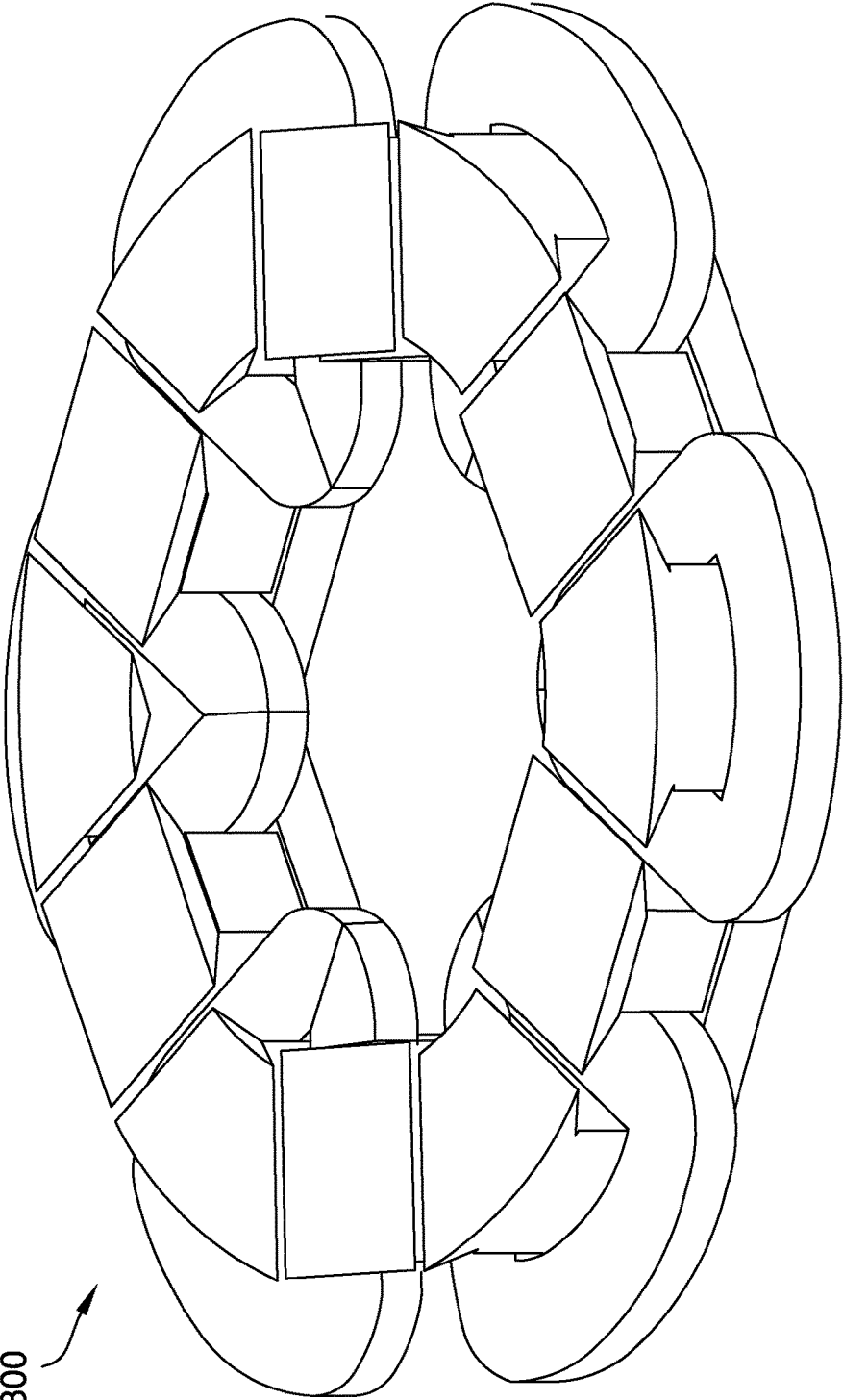

FIG. 23

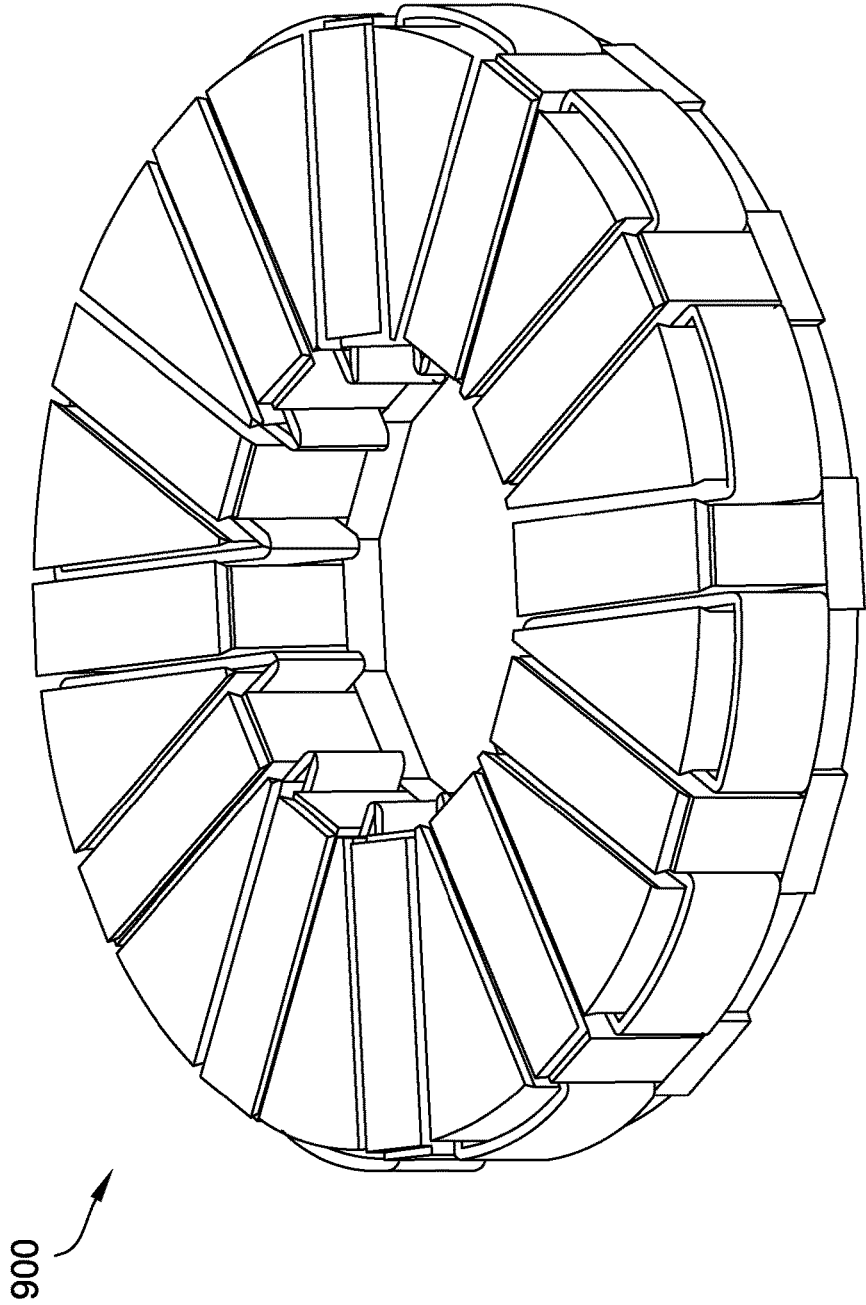

FIG. 24

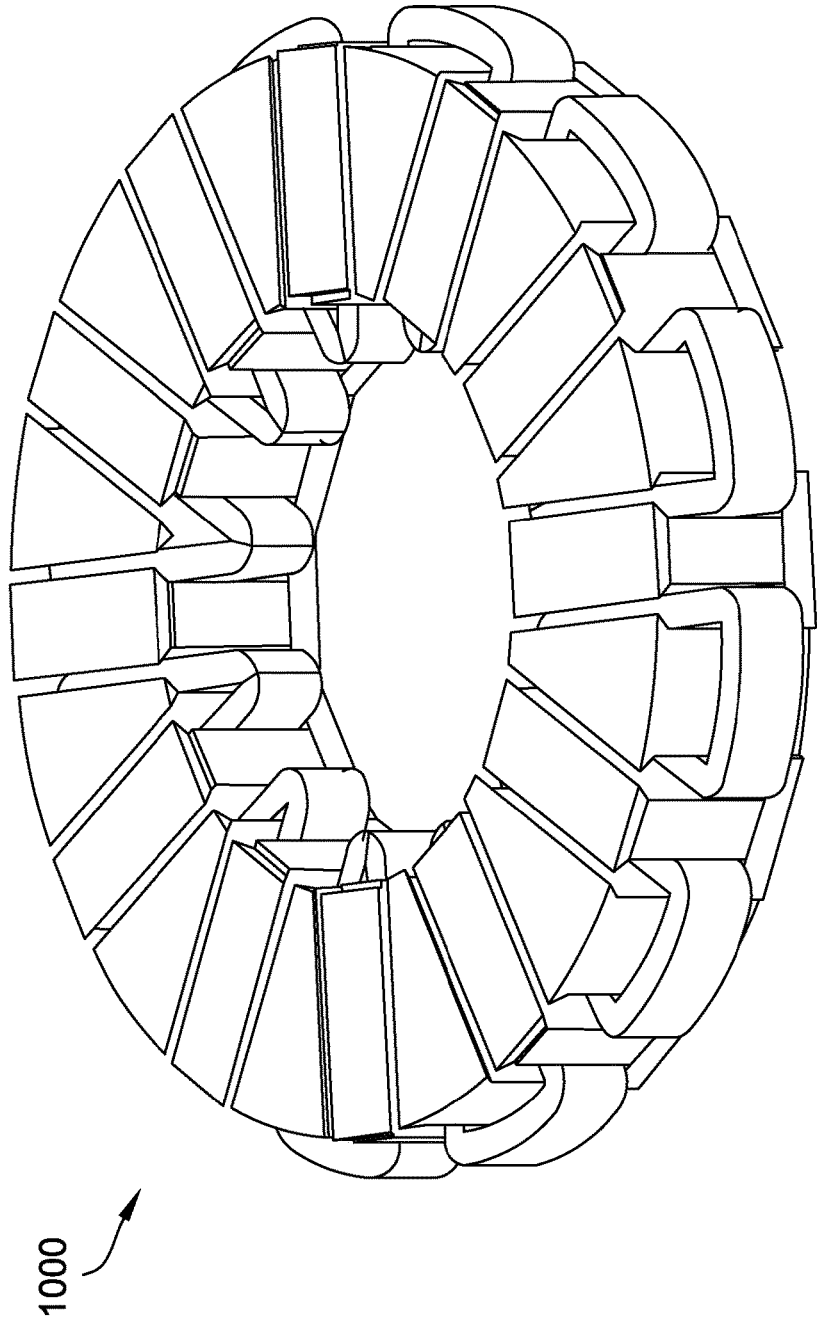

FIG. 25

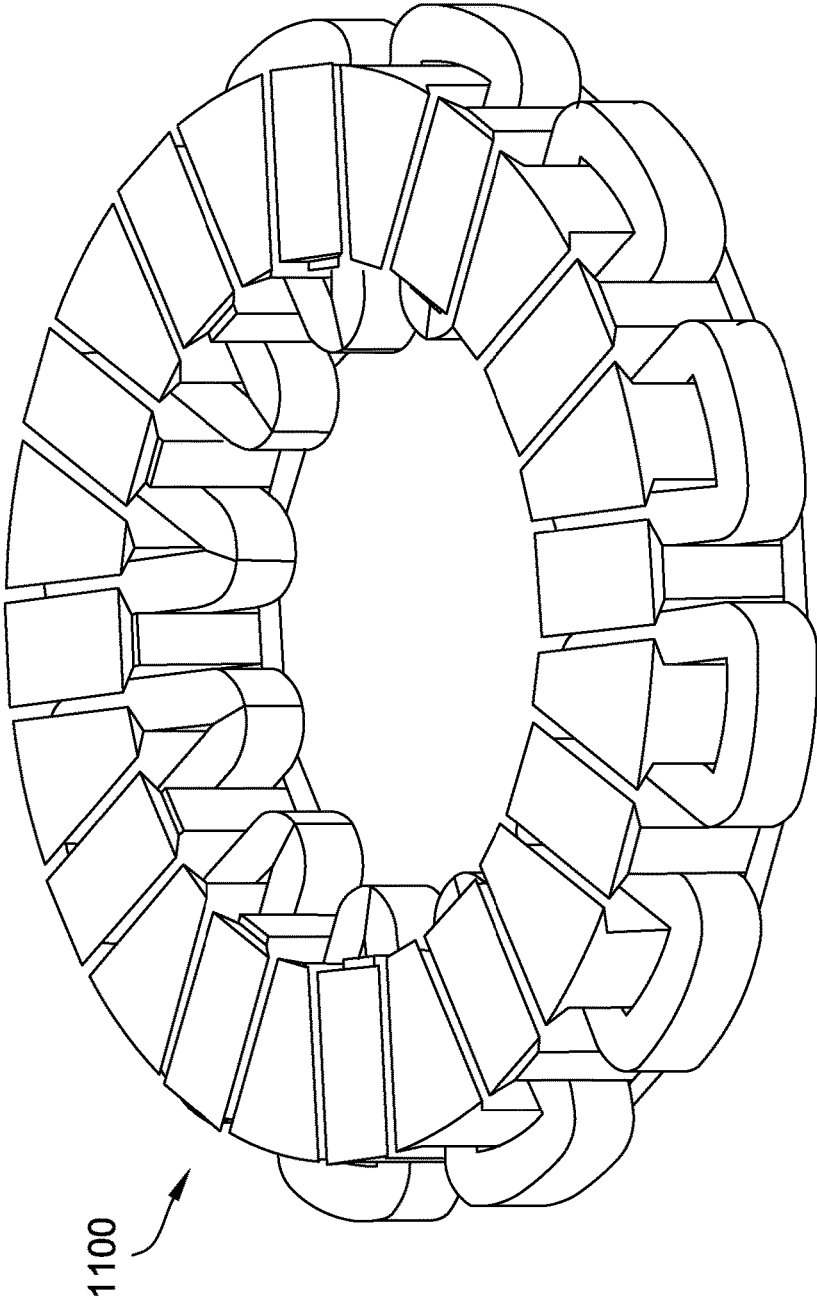

FIG. 26

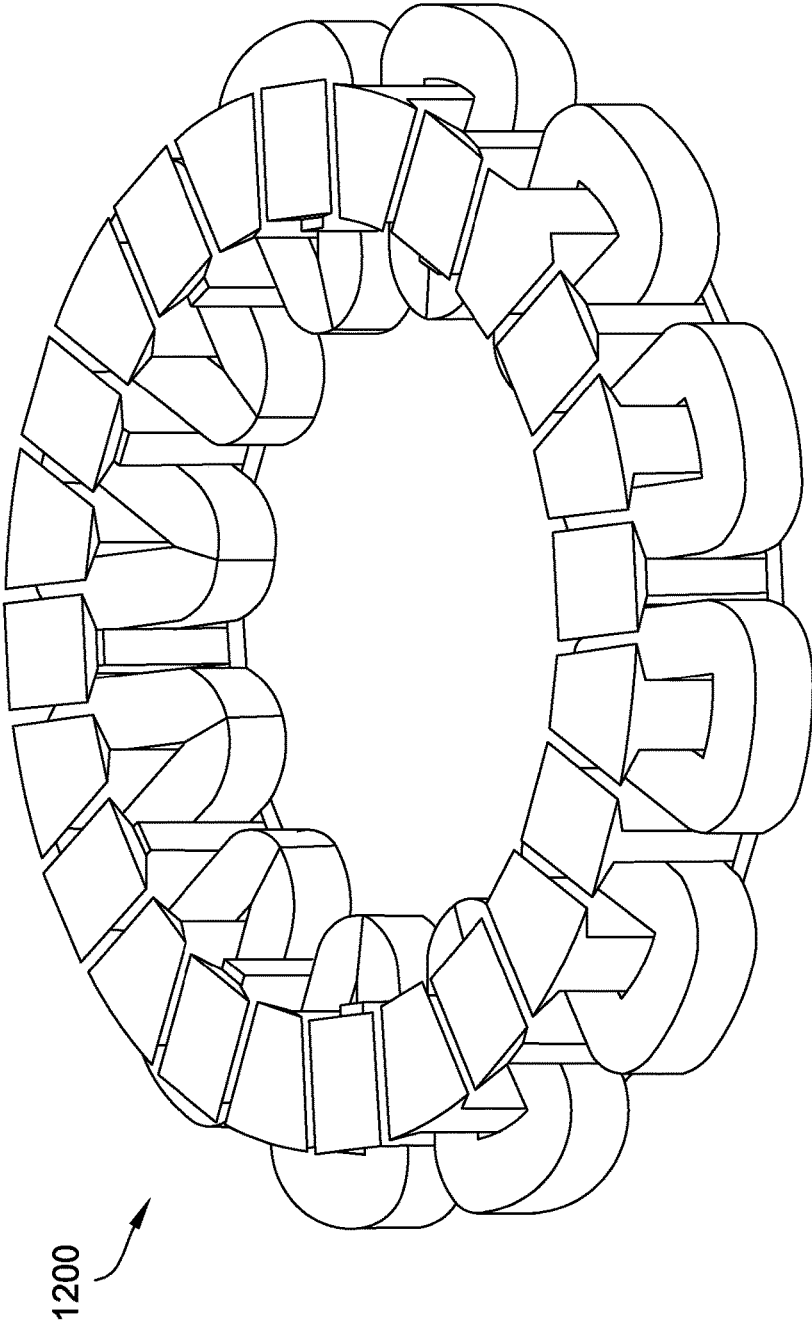

FIG. 27

MODULAR STATOR DRIVE UNITS FOR AXIAL FLUX ELECTRIC MACHINES

BACKGROUND

[0001] The field of the disclosure relates generally to axial flux electric machines, and more specifically, modular stator assemblies for axial flux electric machines.

[0002] One of many applications for an electric motor is to operate a pump or a blower. The electric motor may be configured to rotate an impeller within a pump or blower, which displaces a fluid, causing a fluid flow. Many gas burning appliances include an electric motor, for example, water heaters, boilers, pool heaters, space heaters, furnaces, and radiant heaters. In some examples, the electric motor powers a blower that moves air or a fuel/air mixture through the appliance. In other examples, the electric motor powers a blower that distributes air output from the appliance.

[0003] A common motor used in such systems is an alternating current (AC) induction motor. Typically, the AC induction motor is a radial flux motor, where the flux extends radially from the axis of rotation. Another type of motor that may be used in the application described above is an electronically commutated motor (ECM). ECMs may include, but are not limited to, brushless direct current (BLDC) motors, permanent magnet alternating current (PMAC) motors, and variable reluctance motors. Typically, these motors provide higher electrical efficiency than an AC induction motor. Some ECMs have an axial flux configuration in which the flux in the air gap extends in a direction parallel to the axis of rotation of the rotor.

[0004] At least some known axial flux motors include a rotor with a plurality of permanent magnets and a stator with an annular back iron. The back iron includes a plurality of magnetic teeth formed on the back iron having electrically conductive windings disposed thereon. Unlike radial flux motors in which the rotor is positioned within the stator (or vice versa), the rotor and stator are positioned adjacent each other in a face-to-face configuration. The electromagnetic teeth are annularly disposed around the stator and extend axially towards the permanent magnets from a back iron that couples the teeth to each other. However, these known axial flux motors typically require customized components and costly equipment to manufacture motors with different operating characteristics (e.g., motor size, torque, speed, number of poles, etc.). In addition, maintenance on the components of these motors may be difficult to perform without replacing the entire rotor or stator.

BRIEF DESCRIPTION

[0005] In one aspect, a stator module pack for an axial flux electric machine includes a housing for attachment to a stator base, a plurality of stator modules attached to the housing, and a drive unit attached to the housing. Each stator module includes a core having at least one winding disposed thereon. The drive unit is electrically connected to at least one stator module.

[0006] In another aspect, a stator for an axial flux electric machine includes a stator base and a plurality of stator module packs attached to the stator base. Each stator module pack includes a housing attached to the stator base, a plurality of stator modules attached to the housing, and a

drive unit electrically connected to at least one stator module. Each stator module includes a core having at least one winding disposed thereon.

[0007] In yet another aspect, a three phase stator module pack for an axial flux electric machine includes a housing for attachment to a stator base, a first subset of stator modules attached to the housing, a second subset of stator modules attached to the housing, a third subset of stator modules attached to the housing, and a drive unit attached to the housing and electrically connected to the first subset of stator modules. Each stator module of the first, second and third subsets of stator modules including a core having at least one winding disposed thereon. The drive unit selectively provides electrical current to the first subset of stator modules.

BRIEF DESCRIPTION OF THE DRAWINGS

[0008] FIG. 1 is a cross-sectional view of an exemplary axial flux electric machine.

[0009] FIG. 2 is an exploded view of the axial flux electric machine shown in FIG. 1.

[0010] FIG. 3 is a top plan view of an exemplary rotor that may be used with the axial flux electric machine shown in FIG. 1.

[0011] FIG. 4A is a perspective view of an exemplary rotor module that may be used with the rotor shown in FIG. 3.

[0012] FIG. 4B is an exploded view of the exemplary rotor module shown in FIG. 4A.

[0013] FIG. 5 is a perspective view of an exemplary flux guide with an extended length that may be used with the rotor shown in FIG. 3.

[0014] FIG. 6 is a perspective view of an exemplary flux guide with an extended width that may be used with the rotor shown in FIG. 3.

[0015] FIG. 7 is a perspective view of an exemplary flux guide with an extended length and width that may be used with the rotor shown in FIG. 3.

[0016] FIG. 8 is a perspective view of an exemplary flux guide for a plurality of permanent magnets that may be used with the rotor shown in FIG. 3.

[0017] FIG. 9 is a top plan view of an example stator with curved stator module packs that may be used with the axial flux electric machine shown in FIG. 1.

[0018] FIG. 10 is a perspective view of an exemplary stator module pack that may be used with the stator shown in FIG. 8.

[0019] FIG. 11 is a partial top plan view of an exemplary stator with straight module packs that may be used with the axial flux electric machine shown in FIG. 1.

[0020] FIG. 12 is a top plan view of an exemplary straight stator module pack that may be used with the stator shown in FIG. 11.

[0021] FIG. 13 is a top plan view of an exemplary stator module pack with integrated electric drive units that may be used with the stator shown in FIG. 8.

[0022] FIG. 14 is a perspective view of an exemplary stator with external electric drive unit that may be used with the electric machine shown in FIG. 1.

[0023] FIG. 15 is a perspective view of an example stator module that may be used with the stator module pack shown in FIG. 9.

[0024] FIG. 16 is an exploded view of an example stator module that may be used with the stator module pack shown in FIG. 9.

[0025] FIG. 17 is a flow diagram of an exemplary method for assembling a stator for an axial flux electric machine that may be used to assemble the machine shown in FIG. 1.

[0026] FIG. 18 is a perspective view of an exemplary partial axial flux electric machine.

[0027] FIG. 19 is a perspective view of an exemplary stator that may be used with the axial flux electric machine shown in FIG. 18.

[0028] FIG. 20 is a perspective view of an exemplary twelve slot, 0.55 split ratio stator configuration with alternating tooth segments that may be used with the machine shown in FIG. 1.

[0029] FIG. 21 is a perspective view of an exemplary twelve slot, 0.45 split ratio stator configuration with alternating tooth segments that may be used with the machine shown in FIG. 1.

[0030] FIG. 22 is a perspective view of an exemplary twelve slot, 0.65 split ratio stator configuration with alternating tooth segments that may be used with the machine shown in FIG. 1.

[0031] FIG. 23 is a perspective view of an exemplary twelve slot, 0.75 split ratio stator configuration with alternating tooth segments that may be used with the machine shown in FIG. 1.

[0032] FIG. 24 is a perspective view of an exemplary twenty-four slot, 0.45 split ratio stator configuration with alternating tooth segments that may be used with the machine shown in FIG. 1.

[0033] FIG. 25 is a perspective view of an exemplary twenty-four slot, 0.55 split ratio stator configuration with alternating tooth segments that may be used with the machine shown in FIG. 1.

[0034] FIG. 26 is a perspective view of an exemplary twenty-four slot, 0.65 split ratio stator configuration with alternating tooth segments that may be used with the machine shown in FIG. 1.

[0035] FIG. 27 is a perspective view of an exemplary twenty-four slot, 0.75 split ratio stator configuration with alternating tooth segments that may be used with the machine shown in FIG. 1.

DETAILED DESCRIPTION

[0036] The systems and methods described herein relate generally to axial flux electric machines, and more specifically, to modular assemblies for axial flux electric machines. As used herein, an “axial flux electric machine” is a motor or generator that uses axial flux to generate a power output (mechanical power output for the motor and electrical power output for the generator).

[0037] FIG. 1 is a cross-sectional view of an exemplary axial flux electric machine 10. FIG. 2 is an exploded view of axial flux electric machine 10. In the example embodiment, electric machine 10 is an electric motor. Alternatively, electric machine 10 may operate as an electric generator. In comparison to radial flux electric machines, axial flux electric machine 10 has a relatively small axial length. Axial flux electric machine 10 generally includes a rotor 18, a first bearing assembly 20, a second bearing assembly 22, and a stator 24.

[0038] In the exemplary embodiment, rotor 18 generally includes a rotor base 30 coupled to a shaft 32. A plurality of rotor modules 34 are coupled to rotor base 30. As described in detail further herein, each rotor module 34 includes one or more permanent magnets (not shown in FIG. 1). Rotor

assembly 18 is rotatable within housing 16, and more specifically, rotatable within first bearing assembly 20 and second bearing assembly 22 about an axis of rotation 36. In the exemplary embodiment, rotor 18 is driven by an electronic control (not shown), for example, a sinusoidal or trapezoidal electronic control.

[0039] Stator 24 includes a stator base 50 and at least one stator module pack 52 that is configured to generate axial flux towards rotor modules 34. An air gap 38 is formed between a rotor outer surface and a stator outer surface, and a magnetic flux within machine 10 extends between rotor modules 34 and stator 24 in a direction parallel to axis 36.

[0040] FIG. 3 is a perspective view of an example rotor 100 that may be used with the axial flux electric machine 10 shown in FIG. 1. Rotor 100 includes a rotor base 102, a shaft 104, and a plurality of rotor modules 106 attached to rotor base 102. In other embodiments, rotor 100 includes additional, fewer, or alternative components, including those described elsewhere herein.

[0041] In the example embodiment, rotor base 102 is a circular disk having a circumferential outer edge 108 and an inner edge 110. In other embodiments, rotor base 102 has a different shape. Rotor base 102 has an outer radius R_o , and an outer circumference. In the example embodiment, rotor base 102 may be fabricated from a non-magnetic material, such as plastic, aluminum, and stainless steel. In other embodiments, rotor base 102 is at least partially fabricated from a magnetic material. Shaft 104 extends through an opening 112 defined by inner edge 110. Shaft 104 may be configured to rotate with rotor base 102 to generate mechanical (motor) or electrical (generator) power. Alternatively, shaft 104 may be configured to be stationary such that rotor 100 generates power without movement of shaft 104. Rotor base 102 is configured to rotate in response to magnetic forces associated with rotor modules 106 as described herein.

[0042] Rotor modules 106 are disposed on a face surface 103 of rotor base 102 such that rotor modules 106 are substantially aligned with stator module packs (e.g., packs 52, shown in FIG. 1) on an adjacent stator. In the example embodiment, ten rotor modules 106 are circumferentially attached to rotor base 102 proximate outer edge 108 on face surface 103. In other embodiments, a different number of rotor modules 106 (including one) are attached to rotor base 102. Although rotor modules 106 are shown in a single row on rotor base 102, it is to be understood that rotor modules 106 may be attached to rotor base in multiple rows that are radially spaced and/or circumferentially spaced from each other. In certain embodiments, rotor modules 106 are disposed on face surface 103 in a non-uniform configuration (i.e., spacing varies between at least some adjacent rotor modules 106). In at least some embodiments, rotor base 102 and/or rotor modules 106 include one or more slots, fasteners, tabs, openings, hooks, and other components to facilitate secure attachment of rotor modules 106 to rotor base 102. In the exemplary embodiment, rotor modules 106 include fastener openings 107 (shown in FIG. 4B) that are configured to align with a corresponding hole (not shown) on rotor base 102 and receive a fastener, such as a screw or bolt, to secure rotor modules 106 to rotor base 102. Adjacent rotor modules 106 define an arc that is similar to an arc defined by outer edge 108. In other embodiments, rotor modules 106 are attached to rotor base 102 in other suitable configurations.

[0043] FIG. 4A is a perspective view of an example rotor module 106 and FIG. 4B is an exploded view of the example rotor module 106 that may be used with rotor 100 shown in FIG. 3. FIGS. 4A and 4B are collectively referred to herein as FIG. 4. Each rotor module 106 includes a back iron segment 114 (shown in FIG. 4B) configured to attach to rotor base 102 and a plurality of permanent magnets 116 attached to back iron segment 114. In the exemplary embodiment, back iron segment 114 includes openings 107 that are configured to receive a fastener to secure rotor module 106 to stator base 102. Back iron segment 114 is fabricated from a magnetic material to provide a flux path between magnets 116. The magnetic material may include, but is not limited to, laminated steel, soft magnetic composite (SMC), ferromagnetic steel, and combinations thereof.

[0044] Rotor module 106 has an inner arcuate length L_{bi} and an outer arcuate length L_{bo} . The outer length L_{bo} is less than the circumference of rotor base 102 such that multiple rotor modules 106 can be attached to a single rotor base 102. The lengths L_{bi} and L_{bo} are defined by the radius R_r of rotor base 102 and an arc angle of rotor module 106. In some embodiments, rotor module 106 may be substantially straight such that lengths L_{bi} and L_{bo} are substantially linear. Attaching multiple straight modules 106 around rotor base 102 at different angles enables modules 106 to approximate an arc around rotor base 102. The curvature or arc angle of rotor module 106 is defined by the radius R_r of rotor base 102. Alternatively, the radius R_r is determined based on the number of rotor modules 106 and the curvature of rotor modules 106. In other embodiments, the arc angle of rotor module 106 is dependent upon a different feature or design parameter of machine 10 (shown in FIG. 1).

[0045] Magnets 116 are attached to back iron segment 114 in a configuration where they are spaced from each other. In other embodiments, magnets 116 may be combined together as one or more magnets with a plurality of poles. Magnets 116 are secured to back iron segment 114 using any suitable connection means, such as adhesive, clamps, friction-fit, and other suitable means. In the example embodiment, back iron segment 114 includes ten magnets 116. In other embodiments, back iron segment 114 includes any suitable number of magnets 116, and in particular, any even number of magnets 116. Adjacent magnets 116 have opposite polarities for forming flux paths between magnets 116. With magnets 116 of opposite polarities and a magnetic back iron segment 114, adjacent rotor modules 106 may be electromagnetically separate from each other (i.e., no flux paths are provided between adjacent rotor modules 106) and still operate. That is, each rotor module 106 is configured to provide a complete magnet path between a first magnet 116, back iron segment 114, and a second magnet 116 having a polarity opposite the polarity of the first magnet 116. In one embodiment, rotor 100 includes the same number of magnets 116 as the number of windings and/or teeth of an adjacent stator (not shown in FIG. 3). In the exemplary embodiment, permanent magnets 116 are fabricated from neodymium and are formed in a trapezoid-shape. However, any suitable permanent magnet shape and material may be used that enables electric machine 10 to function as described herein.

[0046] In the example embodiment, each rotor module 106 further includes a magnet retainer 120. In other embodiments, rotor modules 106 do not include magnet retainer 120. Magnet retainer 120 is fabricated from a non-magnetic

material (e.g., plastic). In at least some embodiments, magnet retainer 120 is fabricated from a non-conductive material. Magnet retainer 120 is coupled to rotor base 102 and/or back iron segment 114 such that magnet retainer 120 extends axially towards an adjacent stator. In the example embodiment, magnet retainer 120 includes slots 122 that are aligned with magnets 116 such that a face surface 124 of magnets 116 is exposed. In some embodiments, during assembly of rotor module 106, magnet retainer 120 is coupled to back iron segment 114 prior to installing magnets 116. In such embodiments, slots 122 are configured to facilitate aligning magnets 116 on back iron segment 114. In other embodiments, slots 122 are sized and/or shaped to prevent magnets 116 from moving in the axial direction towards the stator and to secure magnets 116 to back iron segment 114.

[0047] In the exemplary embodiment, back iron segment 114 includes a tab 126 extending beyond magnet retainer 120 and an opening 128. In at least some embodiments, tab 126 and opening 128 are formed by positioning back iron segment 114 out of alignment with respect to guard 120. That is, tab 126 is a portion of back iron segment 114 and opening 128 is defined by guard 120 and the absence of back iron segment 114. Tab 126 is configured to be inserted into opening 128 of an adjacent rotor module 106 to secure adjacent rotor modules 106 together. In some embodiments, tab 126 and/or opening 128 include hooks, slots for fasteners, and/or other features to facilitate coupling adjacent rotor modules 106 together. In other embodiments, back iron segment 114 does not include tab 126 or opening 128. For example, if the length L_b of rotor module 106 is substantially straight, guard 120 may not include tab 126 and opening 128 due to the angled positions of adjacent rotor modules 106. Alternatively, adjacent rotor modules 106 may be physically separate from one another.

[0048] Rotor modules 106 are configured to enable a user to design, assemble, and maintain a customized axial flux electric machine. That is, rotor modules 106 may be mass-produced with various curvatures, number of magnets, and the like. When the user designs an electric machine, the user determines a size and shape of the stator as described herein. Based on the determined size and shape of the stator, the user determines the size of rotor base 102. Rotor base 102 may have a substantially similar size and shape as the stator. Alternatively, rotor base 102 may have a different suitable size and shape. Rotor modules 106 are then attached to rotor base 102 to define or approximate an arc similar to the arc defined by the stator modules of the stator to facilitate a flux path between the stator and rotor 100.

[0049] During operation, magnetic forces cause magnetic flux to flow from permanent magnets 116 to the closest stator module (not shown in FIGS. 3 and 4). When magnets 116 are not aligned with a stator module, a portion of the available flux may be lost (i.e., the stator module does not capture all of the available flux). Generally, the more effectively that available flux that is channeled from permanent magnets 116 and captured by the stator modules, the more efficient machine 10 operates. Therefore, it is desirable to cause as much flux as possible to be captured by the stator modules. However, because the plurality of permanent magnets 116 are rotating above the stator, magnets 116 are not always positioned directly over the stator modules to provide for a straight flow path of flux from magnets 116 to the modules.

[0050] In some known electric machines, the flux changes magnitude within the body of the magnets to reach the stator modules. The change in flux magnitude creates eddy currents, which may cause heat generation and torque losses, potentially resulting in a reduction in operating efficiency of the machine. Additionally, the heat produced by the eddy currents may cause demagnetization of the magnets and/or failure of an adhesive used to retain the magnets within the rotor, which may cause the magnets to disengage from the rotor, resulting in failure of the machine. Furthermore, in some known machines, some flux may not be channeled to the stator and may leak to a different part of the rotor or the stator. Such leakage may not only cause a reduction in torque generation, thereby making the machine potentially less efficient, but also may cause an undesirable dynamic force distribution inside the machine that may lead to increased noise production and vibration.

[0051] In at least some embodiments, rotor 100 includes a flux guide (not shown in FIGS. 3 and 4) for one or more magnets 116 to facilitate reduced eddy currents, noise, and vibrations. The flux guide (also sometimes referred to as a “magnet shim” or a “magnet tip”) is positioned on magnet 116 such that the flux guide is between magnet 116 and an adjacent stator. In some embodiments, the flux guide is secured to magnet 116 (e.g., using an adhesive). In the example embodiment, the flux guides are manufactured from an isotropic SMC material, such as Somaloy® (available from Höganäs AB of Höganäs, Sweden). In other embodiments, the flux guides are manufactured from a different magnetic material. In the exemplary embodiment, the flux guides have a thickness of approximately 2 millimeters. Alternatively, the flux guides may have any thickness that enables machine 10 to function as described herein. An air gap (e.g., air gap 38, shown in FIG. 1) is defined between the flux guide and the stator.

[0052] The flux guide has a shape and a size that enables the flux guide to at least partially cover face surface 124 of magnet 116. In the example embodiment, the flux guide is configured to extend beyond the majority of the edges of surface 124 of magnet 116 to which it is attached to direct flux from magnets 116 to the stator and back. For example, the flux guides may have a width and a length that extends beyond a corresponding width and length of magnet 116. This overhang facilitates additional degree(s) of freedom when optimizing noise, cost, and efficiency of rotor 100 and the configuration of magnets 116. The shape of the flux guide is any suitable shape to enable machine 10 to function as described herein. In one example, the shape of the flux guide is substantially similar to the shape of magnet 116. In another example, the shape of the flux guide is different from the shape of magnet 116. As used herein with respect to flux guides, a “different shape” in comparison to a first shape may include another geometrical shape (e.g., cylinder, cube, etc.) different from the first shape or the same geometrical shape as the first shape but with different lengths, widths, arcs, angles, and so forth. For example, if the flux guide and magnet 116 are both trapezoids having different arc angles, the flux guide and magnet have different shapes. In certain embodiments, rotor 100 may include at least two different shaped or sized flux guides to function as described herein.

[0053] In some embodiments, the adjacent flux guides define an arc substantially similar to the arc defined by rotor modules 106. For example, if rotor modules 106 have a substantially straight length L_r and are attached to rotor base

102 at different angles to approximate an arc around rotor base 102, the flux guides may be coupled to rotor modules 106 to define a substantially uniform annular arc around rotor base 102. In certain embodiments, each flux guide is positioned on more than one magnet 116 and extends to or beyond the edges of surface 124 for each magnet 116 to which it is attached.

[0054] During operation of machine 10, the flux generated by magnet 116 is channeled to one or more stator modules by a respective flux guide. When magnet 116 is not aligned with a stator module, the flux guide steers or channels portions of the flux from magnet 116 to nearby stator modules. By channeling flux to the stator modules through the flux guides to reduce the change in flux magnitude within magnets 116, the formation of eddy currents within magnets 116 is substantially reduced or otherwise eliminated.

[0055] Substantially all of the flux generated by magnets 116 is channeled to and captured by the stator modules, resulting in higher torque production and more efficient operation of machine 10. Additionally, the flux guides facilitate reducing the leakage of flux to components of machine 10 other than the stator modules because substantially all of the flux is captured by the stator modules. The reduction of flux leakage reduces the dynamic force distribution within machine 10 and, therefore, reduces the generation of endemic noise and vibrations. Furthermore, the reduction or elimination of eddy currents within magnets 116 reduces the amount of heat generated by machine 10, which results in higher efficiency and facilitates retention of magnets 116 within rotor 100.

[0056] In at least some embodiments, the flux guides are extended beyond the edges of magnets 116 to provide a potential leakage path for flux. The leakage path is insignificant for small air gaps between the flux guide and a stator module (i.e., when the stator module is directly aligned with the flux guide), but increases the rate of flux reduction into a particular stator module as the air gap increases.

[0057] FIGS. 5-8 are perspective views of some example flux guide configurations that may be used with rotor 100 shown in FIG. 3. In particular, FIG. 5 is a perspective view of a first flux guide 140 having an extended length L_f . FIG. 6 is a perspective view of a second flux guide 150 having an extended width W_f . FIG. 7 is a perspective view of a third flux guide 160 having an extended length L_f and width W_f and FIG. 8 is a perspective view of a fourth flux guide 170 positioned on a plurality of permanent magnets 172. Flux guides 140, 150, 160, and 170 are shown for descriptive purposes only, and are not meant to limit the configuration of flux guides as described herein.

[0058] With respect to FIGS. 5-7, each flux guide 140, 150, and 160 is positioned on a respective magnet 116. In particular, flux guides 140, 150, and 160 are positioned on face surface 124 of magnet 116. In the exemplary embodiments, flux guides 140, 150, and 160 have an arcuate trapezoidal shape similar to the shape of magnet 116. In another embodiment, magnets 116 are shaped as a portion or section of an annulus defined by all of magnets 116. In other embodiments, flux guides 140, 150, and 160 have a different shape and are not required to be the same shape as magnet 116. Magnet 116 has an arcuate inner edge 132, an arcuate outer edge 134, a first side edge 136, and an opposing second side edge 138. Face surface 124 is defined by edges 132, 134, 136, and 138. Arcuate inner edge 132 has an arc length less than the arc length of outer edge 134 such that face

surface 124 tapers inwardly. In the exemplary embodiment, when rotor 100 is assembled, inner edge 132 of magnet 116 is positioned towards inner edge 110 of rotor base 102 and outer edge 134 of magnet 116 is positioned towards outer edge 108 of rotor base 102 (each shown in FIG. 3). Side edges 136 and 138 are positioned towards adjacent magnets 116 on rotor 100.

[0059] With respect to FIG. 5, flux guide 140 includes a magnet surface 141, an arcuate inner edge 142, a gap surface 143, an arcuate outer edge 144, a first side edge 146, and a second side edge 148. Magnet surface 141 is positioned adjacent face surface 124 of magnet 116. Gap surface 143 is oriented towards a stator (not shown in FIG. 5) during operation. Inner edge 142 is smaller than outer edge 144 such that magnet surface 141 and gap surface 143 taper inwardly. The arc length of inner edge 142 is less than the arc length of outer edge 144. Flux guide 140 has a maximum width W_f defined between first and second side edges 146 and 148 that is substantially similar to a width of magnet 116. The length L_f of flux guide 140 is defined between inner edge 142 and outer edge 144 and extends beyond inner and outer edges 132 and 134 of magnet 116 such that flux guide 130 covers the entirety of face surface 124. In some embodiments, flux guide 140 may extend beyond only one of inner edge 132 and outer edge 134 of magnet 116. In at least some embodiments, flux guide 140 is tapered such that an air gap (e.g., air gap 38, shown in FIG. 1) between flux guide 140 and a stator tooth at inner edge 142 is different from an air gap at outer edge 144. The tapered air gap facilitates balancing flux entering an inner edge and an outer edge of a stator tooth to prevent flux from flowing perpendicular to the laminations of the stator tooth.

[0060] With respect to FIG. 6, flux guide 150 includes a magnet surface 151, an arcuate inner edge 152, a gap surface 153, an arcuate outer edge 154, a first side edge 156, and a second side edge 158. Flux guide 150 and magnet 116 have different arc angles. Magnet surface 151 is positioned adjacent face surface 124 of magnet 116. Gap surface 153 is oriented towards a stator (not shown in FIG. 6) during operation. Flux guide 150 has a length L_f defined between inner and outer edges 152 and 154 that is substantially similar to a length of magnet 116. The maximum width W_f of flux guide 150 is defined between first and second side edges 156 and 158 and extends beyond first and second side edges 136 and 138 of magnet 116 such that flux guide 130 covers the entirety of face surface 124. In some embodiments, flux guide 150 may extend beyond only one of first side edge 136 and second side edge 138 of magnet 116. In at least some embodiments, flux guide 150 is tapered between inner edge 152 and outer edge 154 to provide a different size air gaps at each edge 152, 154.

[0061] With respect to FIG. 7, flux guide 160 includes a magnet surface 161, an inner edge 162, an air gap surface 163, an outer edge 164, a first side edge 166, and a second side edge 168. Magnet surface 161 is positioned adjacent to face surface 124 of magnet 116. Air gap surface 163 is oriented towards a stator (not shown in FIG. 7) during operation. Flux guide 160 has a length L_f defined between inner and outer edges 162 and 164 and a width W_f defined between first and second side edges 166 and 168. The length L_f and width W_f of flux guide 160 extends beyond the length and width of magnet 116 to cover the entirety of face surface 124. In at least some embodiments, flux guide 160 is tapered

between inner edge 162 and outer edge 164 to provide a different size air gaps at each edge 162, 164.

[0062] With respect to FIG. 8, flux guide 170 is similar to flux guides 140, 150, and 160 and includes similar components. Flux guide 170 is positioned on a plurality of cylindrical magnets 172. Magnets 172 have a face surface 174 that is adjacent to magnet surface 171 of flux guide 170, a back iron surface 176, an edge portion 178 and a radius R_{mg} that is less than the length L_f and width W_f of flux guide 170. Edge portion 178 extends between face surface 174 and back iron surface 176. Magnets 172 only have a single edge portion 178 because of their cylindrical shape. However, in other embodiments, magnets 172 may have a plurality of edge portions if magnets 172 have a different shape, such as a rectangle or a trapezoid. Although magnets 172 are shown having uniform shapes and sizes, it is to be understood that any suitable combinations of shapes and sizes can be used for magnets 172. Irrespective of the size and shape of magnets 172, flux guide 170 is configured to cover face surface 174 of each and every magnet 172. In at least some embodiments, flux guide 170 is configured to extend beyond magnets 172 in at least one direction.

[0063] FIG. 9 is a top plan view of an example stator 200 that may be used with the axial flux electric machine 10 shown in FIG. 1. Stator 200 may be a multiphase stator (e.g., three phases) or a single phase stator that produces flux in the axial direction (i.e., parallel to axis of rotation 36 shown in FIG. 1). Stator 200 includes a stator base 202 and a plurality of stator module packs 204 attached to stator base 202. In other embodiments, stator 200 includes additional, fewer, or alternative components, including those described elsewhere herein. FIG. 10 is a partial exploded view of a curved stator module pack 204.

[0064] With respect to FIGS. 9 and 10, stator base 202 has a circular shape and includes an outer edge 206 that defines a circumference and a radius R_s of base 202. In other embodiments, stator base 202 may be a different shape or size. The shape and/or size of stator base 202 may be determined based on an intended use of the axial flux machine with stator 200 and/or the number of stator module packs to be installed on stator base 202. In the example embodiment, stator base 202 is fabricated from a material or combination of materials having a suitable rigidity and strength to support stator module packs 204. In some embodiments, stator base 202 is a non-magnetic material or combination of materials, such as a plastic or non-magnetic metal. Alternatively, stator base 202 may be fabricated from a magnetic material. Stator base 202 may include or more mounting points (not shown) for coupling stator module packs 204, stator drivers (not shown in FIG. 8), and/or a rotor to stator base 202. In the exemplary embodiment, stator module packs 204 are evenly distributed around stator base 202 in a complete, uniform annulus configuration. In other embodiments, stator module packs 204 may be connected to stator base 202 in a non-uniform configuration (i.e., spacing varies between at least some adjacent stator module packs 204).

[0065] Stator module packs 204 include a housing 208 and one or more stator modules 210 attached to housing 208. Housing 208 includes an inner radial wall 212, an outer radial wall 214, a first end wall 216, a second end wall 218, a face surface 220, and a base surface 222. When stator 200 is assembled, face surface 220 is oriented to face the rotor and base surface 222 is oriented towards stator base 202. The

walls and surfaces of housing 208 define an enclosed volume 224 for stator modules 210. In FIG. 10, face surface 220 is removed from housing 208 to view the interior of volume 224. In some embodiments, face surface 220 includes a plurality of teeth openings 221 that are aligned with stator modules 210 to facilitate transmission of axial flux to the rotor. In other embodiments, face surface 220 does not include teeth openings 221. Housing 208 has an inner arcuate length L_{mi} extending along inner radial wall 212, an outer arcuate length L_{mo} extending along outer radial wall 214, and a width W_m extending from inner radial wall 212 to outer radial wall 214. The inner length L_{mi} is less than the outer length L_{mo} . Although housing 208 is shown as having arcuate lengths L_{mi} and L_{mo} , in some embodiments, housing 208 may be substantially straight to facilitate attaching stator module packs 204 around different stators having different circumferences of stator base 202. In such embodiments, inner and outer lengths L_{mi} and L_{mo} may be substantially similar to each other. In other embodiments, housing 208 has a different shape to facilitate positioning stator modules 210 in a different configuration. For example, although stator modules 210 are shown in a single arc, in some embodiments, housing 208 is configured to facilitate two-dimensional configurations of stator modules 210 and/or radial configurations.

[0066] In the example embodiment, housing 208 is a rigid material to provide protection to stator modules 210 (not shown in FIG. 9). In other embodiments, housing 208 is at least partially flexible to enable stator module pack 204 to be adjusted to a particular curvature or shape, and thus enabling stator module packs 204 to be used for various configurations of stator 200. For example, inner radial wall 212, outer radial wall 214, face surface 220, and base surface 222 may include flexible joints and rigid segments to facilitate adjustment of stator module pack 204. Alternatively, stator module packs 204 may be formed with a rigid housing 208 having a predetermined arc angle or curvature.

[0067] Housing 208 includes one or more mounting points 225 that align with a corresponding mounting point on stator base 202. Mounting points 225 are configured to receive a fastener (e.g., screw, bolt, dowel, clamp, etc.) to secure stator module packs 204 to stator base 202. Additionally or alternatively, housing 208 includes one or more tabs, slots, latches, adhesive, and/or other component that engages stator base 202 to secure stator module packs 204 to stator base 202.

[0068] In the example embodiment, stator module packs 204 are annularly attached to stator base 202 adjacent to each other and outer edge 206. In some embodiments, at least a portion of stator module packs 204 are separated from one or more adjacent packs 204 to define a pack gap (not shown) between adjacent packs 204. The pack gap may be any size, including less than inner arcuate length L_{mi} of housing 208 and greater than outer arcuate length L_{mo} of housing 208. Alternatively, adjacent stator module packs 204 contact each other after assembly of stator 200. Stator module packs 204 are curved to define an arc that aligns with outer edge 206 of stator base 202. In other embodiments, housings 208 have arcuate lengths L_{mi} and L_{mo} that are defined by the radius R_s and an arc angle such that the curvature of housings 208 aligns with the curvature of outer edge 206. Alternatively, stator module packs 204 may be

attached to stator base 202 in a different configuration. In one example, stator module packs 204 are radially attached to stator base 202.

[0069] In the example embodiment, each stator module pack 204 includes six stator modules 210. In other embodiments, stator module pack 204 may include a different number of stator modules 210 (including one). In one example, each stator module pack 204 includes three stator modules 210. In another example, stator 200 includes one or more stator modules 210 with a different number of stator modules 210. Stator modules 210 are positioned adjacent to each other within housing 208 such that a module gap 226 is defined between each adjacent stator module 210. Stator modules 210 are positioned in a single line along the length L_m of housing 208. In the example embodiment, stator modules 210 are positioned in a single, substantially straight line between the inner and outer arcuate lengths L_{mi} and L_{mo} of housing 208 within volume 224. In other embodiments, stator modules 210 are positioned in a different configuration within volume 224. Alternatively, stator module packs 204 may not include modules 210. Rather, in such embodiments, stator module packs 204 include a single portion of a stator core (not shown) that has a plurality of stator teeth.

[0070] In the example embodiment, stator modules 210 are attached to a circuit board 228 that extends along a portion of housing 208 within volume 224. Circuit board 228 is configured to mechanically secure modules 210 together and to electrically couple each module 210 to one or more inputs and outputs (e.g., power input, drive signals, etc.). In some embodiments, circuit board 228 electrically couples at least a portion of modules 210 together. Alternatively, circuit board 228 may electrically isolate each module 210 from each another.

[0071] FIG. 11 is a partial plan view of an exemplary stator 200 with straight stator module packs 230. FIG. 12 is a top plan view of the exemplary straight stator module pack 230. Stator module pack 230 is similar to stator module pack 204 and, in the absence of contrary representation, includes similar components.

[0072] With respect to FIGS. 11 and 12, each stator module pack 230 includes a housing 232 with a substantially straight length L_{ms} . A face surface (not shown) of housing 232 is removed for clarity purposes. Stator module packs 230 are coupled to stator base 202 at different angles to form a group of linear packs 230 that approximate an arc a_r , matching or similar to an arc defined by the radius R_s and outer edge 206 (i.e., the circumference). As the number of packs 230 increases, the angle between adjacent packs 230 decreases such that the arc a_r substantially matches the arc defined by the radius R_s and outer edge 206. The straight module packs 230 enable a user to install stator module packs 230 on a variety of stator bases 202 having different sizes and shapes, thereby increasing the flexibility and modularity of the user's design options for an axial flux electric machine.

[0073] With respect again to FIGS. 9 and 10, each stator module pack 204 is electrically coupled to one or more electric drive units (not shown in FIGS. 9 and 10). As used herein, "electrically coupled" components do not require electricity or current to actually be present between the components, but are coupled such that when current is present, the current is transferred between the electrically coupled components. The electric drive units are coupled to a power source and include one or more drive circuits. The

drive circuits include, for example, inverters, rectifiers, transformers, and the like that facilitate control of the performance of machine 10 (shown in FIG. 1). In some embodiments, the electric drive units are in communication with a controller (not shown). In other embodiments, the electric drive units include an integrated controller. The electric drive units are configured to generate a drive signal to stator module pack 204 to cause axial flux to be generated, thereby facilitating movement of an adjacent rotor. The drive signal for at least some stator modules 210 are synchronized together to increase the torque, speed, and/or efficiency of the rotor. The drive signal may be mono-phase or multi-phase. In one example, three electric drive units operate together to generate a three-phase drive signal. In another example, one electric drive unit generates a three-phase drive signal.

[0074] In some embodiments, one or more electric drive units are electrically coupled to each and every stator module pack 204 on stator 200. In other embodiments, one or more electric drive units are electrically coupled to a subset of stator module packs 204 (i.e., at least one pack 204) of stator 200. In such embodiments, the electric drive units are communicatively coupled to each other to facilitate synchronizing the drive signals together. In some embodiments, each stator module pack 204 is electrically coupled to a single electric drive unit. In other embodiments, each stator module pack 204 includes an electric drive unit for each phase of pack 204. For example, if pack 204 has three phases, three electric drive units are electrically coupled to each pack 204.

[0075] In some embodiments, the electric drive units are attached adjacent stator module packs 204. For example, the electric drive units may be attached to stator base 202 proximate packs 204. In other embodiments, the electric drive units are integrated within the stator modules packs 204 such that each pack 204 acts as a self-contained stator. That is, it is possible to operate machine 10 using only a single stator module pack 204. Packs 204 are electromagnetically independent of each other (i.e., each pack 204 generates and completes a flux path by itself) in at least some embodiments, and therefore may be operated without synchronizing with the other packs 204.

[0076] FIG. 13 is a top plan view of an example stator module pack 204 that includes a plurality of integrated electric drive units 300. Stator module pack 204 is substantially similar to pack 204 shown in FIG. 10 and includes similar components.

[0077] Drive units 300 are electrically coupled to a power input 302 and at least a portion of stator modules 210. Connections with stator modules 210 are not shown in FIG. 13 for clarity purposes. Power input 302 is power provided by an external power source (e.g., a battery or utility power grid). In certain embodiments in which machine 10 (shown in FIG. 1) is a generator, power input 302 is power generated by machine 10. Drive units 300 generate a drive signal based on power input 302 and provide the drive signal to stator modules 210. In one embodiment, the drive signal is a single phase power signal. Alternatively, the drive signal may be a multiphase power signal (e.g., three-phase power). In the example embodiment, each drive unit 300 is coupled to two respective stator modules 210 to provide a different phase of the drive signal such that a cumulative three-phase drive signal is provided to stator modules 210. That is, one electric drive unit 300 generates a drive signal having a first phase,

a second drive unit 300 generates a drive signal having a second phase, and a third drive unit 300 generates a drive signal having a third phase. The drive signals cause stator modules 210 to provide flux paths for flux from a rotor (not shown in FIG. 13) and rotate the rotor.

[0078] In the example embodiment, drive units 300 includes at least a drive circuit 306 and a controller 308. In some embodiments, each drive unit 300 includes a plurality of drive circuits 306, where each drive circuit 306 is electrically coupled to a respective subset of stator modules 210. Drive circuit 306 is configured to convert at least a portion of power input 302 into the drive signal for stator modules 210. Drive circuits 306 may include an inverter and/or an alternating current-to-alternating current (AC-AC) converter depending upon the power input 302. In some embodiments, drive circuit 306 includes other suitable components (e.g., rectifiers, computer storage devices, etc.) that enable drive units 300 to perform as described herein. In some embodiments, each drive unit 300 includes a plurality of drive circuits 306, wherein each drive circuit 306 is coupled to a respective subset of stator modules 210 to provide the drive signals. In one example, drive unit 300 includes three drive circuits 306.

[0079] In the exemplary embodiment, controller 308 includes a processor 310 and a memory device 312. In the exemplary embodiment, controller 308 is integrated within electric drive unit 300. In other embodiments, controller 308 is implemented in one or more processing devices, such as a microcontroller, a microprocessor, a programmable gate array, a reduced instruction set circuit (RISC), an application specific integrated circuit (ASIC), etc. in communication with electric drive unit 300. Accordingly, in this exemplary embodiment, controller 308 is constructed of software and/or firmware embedded in one or more processing devices. In this manner, controller 308 is programmable, such that instructions, intervals, thresholds, and/or ranges, etc. may be programmed for a particular machine 10 and/or an operator of machine 10. Controller 308 may be wholly or partially provided by discrete components, external to one or more processing devices.

[0080] Controller 308 is communicatively coupled to inverter 306 to control inverter 306 and adjust the drive signal. That is, controller 308 determines the frequency and magnitude of the drive signal based on stored instructions, feedback provided from other components of machine 10, and so forth. In one example, controller 308 controls the operation of one or more switches (not shown) within inverter 306 to adjust the drive signal.

[0081] FIG. 14 is a partial perspective view of an exemplary stator 270 that may be used with machine 10 shown in FIG. 1. Stator 270 includes a stator base 272, a stator module pack 274, and an electric drive unit 320. Although only one stator module pack 274 and electric drive unit 320 are shown, it is to be understood that stator 270 may include a plurality of stator module packs 274 and electric drive units 320. Stator 270 is substantially similar to stator 200 (shown in FIG. 9) except electric drive units 320 are attached to stator base 272 outside of stator modules packs 274. Each drive unit 320 is electrically coupled to at least a portion of one stator module pack 274. In other embodiments, each drive unit 320 is electrically coupled to a plurality of packs 274. In the exemplary embodiment, drive units 320 are coupled to a surface of base 272 opposite a surface with stator module packs 274. In other embodiments, drive units

320 may be attached to base **272** and/or packs **274** is any suitable configuration to facilitate operation of machine **10**.

[0082] FIG. 15 is a perspective view of an exemplary stator module **210** for use in a stator module pack (e.g., pack **204**, shown in FIG. 9) and FIG. 16 is an exploded view of the exemplary module **210**. Stator module **210** includes a core **240**, tooth tips **242**, and a bobbin assembly **244**. In other embodiments, stator module **210** includes additional, fewer, or alternative components, including those described elsewhere herein.

[0083] In the exemplary embodiment, core **240** is generally U-shaped and includes a pair of teeth **246** connected by a yoke section **248**. Alternatively, core **240** is a different shape, such as an E-shaped core. In the exemplary embodiment, core **240** is oriented in a generally axial direction such that teeth **246** extend substantially parallel to axis of rotation **36** (shown in FIG. 1). In the example embodiment, core **240** is fabricated from a plurality of stacked laminated sheets **241**. In other embodiments, core **240** is fabricated from a different material.

[0084] In the exemplary embodiment, tooth tips **242** are generally T-shaped and include an axial member **250** and a cross member **252**. Each cross member **252** includes a head surface **254** configured to receive flux from an adjacent rotor. In other embodiments, tooth tips **242** may have a different shape or configuration. In the exemplary embodiment, tooth tips **242** are fabricated from a plurality of stacked laminated sheets **243**. In other embodiments, tooth tips **242** are fabricated from SMC or another magnetic material. Tooth tips **242** include rounded portions **256** to reduce noise by reducing the harmonic content of the back electromagnetic field (EMF) and cogging torque. Tooth tips **242** are generally aligned with a corresponding tooth **246** and increase flux density in stator **200** (shown in FIG. 8) and reduce the length of a winding **258** necessary for stator module **210**.

[0085] Bobbin assembly **244** includes two bobbins **260**. That is, bobbin assembly **244** includes the same number of bobbins **260** as teeth **246** of core **240**. Alternatively, bobbin assembly **244** may include one bobbin **260** positioned on every other tooth **246**, and/or one bobbin **260** positioned on yoke section **248**. Bobbin **260** includes an opening **262** that closely conforms to an external shape of stator module teeth **246** and tooth tip axial member **250**. For example, stator module tooth **246** is configured to be positioned at least partially within a first end (not shown) of opening **262**, and tooth tip axial member **250** is configured to be positioned at least partially within a second end **264** of opening **262**.

[0086] Assembling stator module **210** includes at least one winding **258** around a plurality of bobbins **260**. At least a portion of each tooth **246** of core **240** is inserted into a corresponding bobbin opening **262**. Tooth tips **242** are also coupled to bobbins **260**. Specifically, at least a portion of axial member **250** is inserted into bobbin opening **262**. Once assembled, stator module **210** is placed within a stator module pack **204** for assembly of a stator.

[0087] Using modular packs **204** enables a user to design, assemble and maintain a stator **200** according to particular specifications. That is, packs **204** enable creation of a customized axial flux electric machine without requiring expensive, custom manufacturing systems and processes. Rather, the modularity facilitates mass production of packs **204** that can be selected to design a customized motor. In

addition, the modular design enables packs **204** to be replaced with relative ease for existing electric machines.

[0088] FIG. 17 is a flow diagram of an example method **270** of assembling an axial flux electric machine that may be used to assemble a machine that includes stator **200** shown in FIG. 8. In particular, the axial flux electric machine to be assembled has one or more desired operational characteristics. As used herein, operational characteristics include mechanical and/or electromagnetic properties of the electric machine, such as torque, number of phases, rotations per minute (rpm), electrical current input or output, voltage input or output, power output, and the like.

[0089] To begin, the user determines **272** a number of stator module packs sufficient to produce a stator for the axial flux machine that has the desired operational characteristic(s), such as number of phases, torque, etc. The user determines **274** a radius of the stator based at least in part on the determined number of stator module packs. In particular, the user determines **274** the radius to fit each and every stator module in a desired configuration (e.g., an annularly disposed configuration). In one example, for curved stator module packs, the user calculating an arc angle or arc of the stator modules packs and determines **274** the radius based on the calculated arc angle or arc and the number of stator module packs. In another example, for straight stator module packs, the radius is determined **274** based on an approximated curve defined by the straight module packs. In other embodiments, the user radius of the stator is determined **274** prior to determining **272** the number of stator module packs such that the number of stator module packs is determined **272** based on the determined radius.

[0090] The determined number of stator module packs are attached **276** to a stator base selected based at least in part on the determined radius such that the stator module packs fit on the stator base. In some embodiments, the radius of the stator base matches the determined radius. In other embodiments, the radius of the stator base is different from the determined radius. In one example, the radius of the stator base is greater than the determined radius to include space tolerance between the stator module packs. In another example, the radius of the stator base is greater than the determined radius to satisfy one or more operational characteristics desired by the user. In a further example, the stator base is selected from one or more predetermined sizes such that the radius of the stator base exceeds the determined radius.

[0091] With respect again to FIGS. 15 and 16, having a separate core **240** and tooth tips **242** for each stator module **210** facilitates reduced manufacturing complexity of modules **210**. For example, winding **258** can be wound around teeth **246** prior to installing tooth tips **242**. Moreover, tooth tips **242** are configured to reduce noise and cogging torque and improve performance of machine **10** (shown in FIG. 1).

[0092] In some embodiments, tooth tips **242** are fabrication from a material or combination of materials that is different from the material(s) used to fabricate core **240**. In one example, core **240** is fabricated from laminated steel sheets **241** and tooth tips **242** are fabricated from an SMC material. Using SMC for tooth tips **242** facilitates improved ease of manufacturing for modules **210** while maintaining reasonable manufacturing costs. Moreover, using SMC for tooth tips **242** facilitates improved thermal performance of stator module **210**. That is, SMC-based tooth tips **242**

dissipate heat at a greater rate than laminated steel, thereby reducing potential thermal issues with modules 210.

[0093] FIG. 18 is a partial perspective view of an exemplary axial flux electric machine 400 and FIG. 19 is a perspective view of a stator 402 of electric machine 400. In the exemplary embodiment, machine 400 is a non-modular electric machine. In other embodiments, machine 400 may be configured to be modular similar to machine 10 (shown in FIG. 1). Accordingly, the features and components described herein may be applied to machine 10. Machine 400 includes stator 402 and a rotor 404. Rotor 404 includes a rotor back iron 406 and a plurality of magnets 408 annularly disposed around back iron 406.

[0094] Stator 402 includes a stator back iron 410, a plurality of teeth 412 that extend towards rotor 404, and a plurality of windings 414 that are disposed on teeth 412. Stator back iron 410 is shown as a single, circular back iron. However, in other embodiments, back iron 410 has a different shape and/or includes a plurality of segments that form back iron 410 collectively. Teeth 412 and magnets 408 are radially aligned with respect to each other. In the exemplary embodiment, stator 402 is fabricated from a first magnetic material, such as laminated steel. Each tooth 412 is securely coupled to a respective tooth tip 416 such that tooth tips 416 are between teeth 412 and magnets 408. In the exemplary embodiment, tooth tips 416 have a substantially planar surface and an arcuate trapezoidal shape. Tooth tips 416 have profiled (e.g., rounded, chamfered, complex, etc.) edges that may be otherwise difficult to manufacture with laminated steel. In other embodiments, tooth tips 416 have a different shape, such as a non-planar shape. In the exemplary embodiment, tooth tips 416 are fabricated from a second material different from the first material, such as SMC.

[0095] Tooth tips 416 extend beyond one or more edges of teeth 412 toward an adjacent tooth 412 and tooth tip 416. Adjacent tooth tips 416 define an air gap 417 that is smaller than slots 418 defined between the adjacent tooth tips 416. Slots 418 have a substantially constant W_g between each pair of adjacent teeth 412. Tooth tips 416 are separate from teeth 412 to enable windings 414 to be disposed around teeth 412 with relative ease. That is, windings 414 are inserted within slots 418 to be wound around teeth 412 without needle winding prior to installing tooth tips 416. Tooth tips 416 are coupled to teeth 412 using any suitable means, such as adhesive, fasteners, slots, tabs, and the like. Once coupled to teeth 412, tooth tips 416 define gap 417, which has a width that would require the use of needle winding to install windings 414 after tooth tips 416 are installed.

[0096] In some embodiments, a combination of laminated steel and an SMC material may be used to form a stator. Laminated steel includes a stack of thin, flat sheets of steel that are laminated together to form a three-dimensional object, such as a stator tooth. Typically, the laminated object is a stack of identical stampings that have a fixed cross section in one dimension. This fixed cross section is linearly “extruded” to form a final shape with a constant cross section, thereby limiting the shape of the object. Further, the magnetic properties of laminated objects are distinctly anisotropic. The laminated material carries alternating magnetic flux relatively efficiently in two of the three dimensions. In particular, the two dimensions defined by the plane of lamination efficiently carry. While the laminated material can carry alternating flux in the third dimension, this results

in relatively high losses due to eddy currents circulating in the plane of lamination. Laminated steel is typically a low-cost magnetic material used in electric machines. SMC is a relatively expensive magnetic material that can be molded into a variety of three-dimensional shapes. SMC material is magnetically isotropic such that objects made from SMC carry magnetic flux in any direction inside the 3D object, with substantially identical, relatively low losses in all directions. SMC has a lower magnetic performance in comparison to laminated steel, but laminated steel may require time-consuming manufacturing and may include small imperfections between the laminated sheets that affect the magnetic performance of the steel. Electric machine components formed from SMC are fabricated with relatively simple manufacturing processes and do not have the same imperfection issues as laminated steel. Due to the cost and performance difference of laminated steel and SMC, a combination of the two materials may be used to form a stator.

[0097] FIGS. 20-27 are perspective views of exemplary stator configurations for use in axial flux electric machines (e.g., machine 10 shown in FIG. 1). In particular, each stator includes a plurality of magnetic laminated tooth segments 510, a plurality of magnetic moldable tooth segments 512, and a plurality of windings 514. In the exemplary embodiment, each configuration includes an equal number of laminated tooth segments 510 and moldable tooth segments 512. Alternatively, the stator configurations may include an unequal number of tooth segments 510 and 512. Laminated tooth segments 510 and moldable tooth segments 512 have different shapes. In the exemplary embodiment, the different shapes approximate a solid, thick-walled cylinder when the parts are assembled. In each stator configuration, laminated tooth segment segments 510 and moldable tooth segments 512 are interleaved such that each laminated tooth segment 510 is between two moldable tooth segments 512 and each moldable tooth segment 512 is between two laminated tooth segment segments 510. Each winding 514 is disposed on a respective moldable tooth segment 512.

[0098] It is to be understood that other materials beyond laminated steel (including non-laminated materials having suitable characteristics to function as described herein) may be used to fabricate laminated tooth segment segments 510. Similarly, moldable tooth segments 512 may be fabricated a different material other than SMC, even non-composite material. Moreover, the stator configurations shown in FIGS. 20-27 are for illustrative purposes only, and are not intended to limit the stator configurations described herein.

[0099] FIG. 20 is a perspective view of an exemplary stator configuration 500. The stator configurations of FIGS. 21-27 are similar to stator configuration 500, and therefore include similar components. Stator configuration 500 has an inner radius R_i and an outer radius R_o . Laminated tooth segment segments 510 include a tooth tip 520, a tooth section 521, and a yoke section 522. Tooth tip 520 is coupled to tooth section 521 at a first end and includes an inner edge 524 and an outer edge 526. Tooth section 521 extends from yoke section 522. In the exemplary embodiment, tooth tip 520, tooth section 521, and yoke section 522 are substantially the same at inner edge 524 and outer edge 526 because the laminated sheets that form laminated tooth segment segments 510 are substantially identical to each other.

[0100] Moldable tooth segments 512 include a tooth tip 530, a tooth section 531, and a yoke section 532. Tooth tips

530 are coupled to a first end of tooth section **531** and include an inner edge **534** and an outer edge **536**. Unlike laminated tooth segment segments **510**, tooth tip **530**, tooth section **531**, and yoke section **532** of moldable tooth segments **512** are substantially different at inner edge **534** and outer edge **536**. In particular, moldable tooth segments **512** are smaller at inner edge **534** in comparison to outer edge **536**. Using SMC to fabricate moldable tooth segments **512** facilitates non-uniform three-dimensional shapes, such as those shown in FIGS. 20-27. Laminated tooth segments **510** and moldable tooth segments **512** are coupled together at a second end opposite the first ends coupled to tooth tips **520** and **530**. In the exemplary embodiment, windings **514** are disposed on moldable tooth segments **512** and are positioned between tooth sections **521** and yoke section **531** of adjacent laminated tooth segment segments **510** and moldable tooth segments **512**, respectively.

[0101] In the exemplary embodiment, as flux traverses from the top of one tooth segment down within stator configuration **500**, the flux turns in either a clockwise or an anticlockwise direction and then comes up via an adjacent tooth segment. The flux will spend some distance in laminated steel (i.e., laminated tooth segments **510**), and some in SMC (i.e., moldable tooth segments **512**). In an axial flux electric machine, there is always at least some movement of the flux path in a “radial” direction. The differences in the magnetic properties of laminated steel, which is anisotropic, and SMC, which is isotropic, mean that for a substantially “minimum energy” solution for the actual position of each path, the flux path will travel close to a straight line in the laminated steel due to the relatively low permeability of flux moving perpendicularly to the lamination direction, and nearly all of the radial movement of the flux path will take place in the SMC.

[0102] Stator configuration **500** is a twelve slot stator configuration with a split ratio (i.e., the ratio between the diameter of inner edge **534** and the diameter of outer edge **536**) of 0.55. FIGS. 21-23 are perspective views of other twelve slot stator configurations **600**, **700**, and **800**. Unlike stator configuration **500**, stator configuration **600** has a split ratio of 0.45, configuration **700** has a split ratio of 0.65, and configuration **800** has a split ratio of 0.75. FIGS. 24-27 are perspective views of stator configurations **900**, **1000**, **1100**, and **1200**. Stator configurations **900**, **1000**, **1100**, and **1200** are twenty-four slot stator configurations with split ratios of 0.45, 0.55, 0.65, and 0.75, respectively.

[0103] The foregoing systems and methods facilitate various improvements to axial flux electric machines. In particular, the foregoing systems and methods facilitate manufacturing improvements, cost improvements, maintenance improvements, and performance improvements to axial flux machines. For example, the modular rotor modules and stator modules packs facilitate improved design and maintenance flexibility for axial flux electric machines. The modular rotors and stators facilitate high volume production of the modular components, which may result in reduced manufacturing costs for each component. Using a combination of laminated steel and SMC materials either as separate teeth and tooth tips or as alternating tooth segments facilitate design flexibility and improved performance of the electric machines without substantially increasing the cost of the electric machine.

[0104] This written description uses examples to disclose the invention, including the best mode, and also to enable

any person skilled in the art to practice the invention, including making and using any devices or systems and performing any incorporated methods. The patentable scope of the invention is defined by the claims, and may include other examples that occur to those skilled in the art. Such other examples are intended to be within the scope of the claims if they have structural elements that do not differ from the literal language of the claims, or if they include equivalent structural elements with insubstantial differences from the literal languages of the claims.

What is claimed is:

1. A stator module pack for an axial flux electric machine, said stator module comprising:
 - a housing configured for attachment to a stator base;
 - a plurality of stator modules attached to said housing, each stator module comprising a core having at least one winding disposed thereon; and
 - a drive unit attached to said housing and electrically connected to at least one stator module of said plurality of stator modules.
2. The stator module pack in accordance with claim 1, wherein said housing defines an enclosed volume, said plurality of stator modules and said drive unit are disposed within the enclosed volume.
3. The stator module pack in accordance with claim 1, wherein said drive unit is electrically connected to all stator modules of said plurality of stator modules, said drive unit configured to selectively couple electrical current to said plurality of stator modules.
4. The stator module pack in accordance with claim 1, wherein said drive unit comprises a plurality of drive circuits, each drive circuit of said plurality of drive circuits coupled to a different subset of stator modules of said plurality of stator modules, wherein each subset of stator modules comprises less than all stator modules of said plurality of stator modules and no stator module is in more than one subset of stator modules.
5. The stator module pack in accordance with claim 4, wherein said plurality of drive circuits consists of three drive circuits, each drive circuit configured to selectively provide a different phase of electrical current drive to a respective subset of stator modules.
6. The stator module pack in accordance with claim 1, wherein said drive unit is electrically connected to a first subset of stator modules of said plurality of stator modules, said first subset of stator modules comprising less than all stator modules of said plurality of stator modules, said drive unit configured to selectively couple power to said first subset of stator modules.
7. The stator module pack in accordance with claim 6 further comprising an additional drive unit, said additional drive unit electrically connected to a second subset of stator modules of said plurality of stator modules, said second subset of stator modules comprising less than all stator modules of said plurality of stator modules, said second subset of stator modules comprising different stator modules than said first subset of stator modules, said additional drive unit configured to selectively couple electrical current to said second subset of stator modules.
8. The stator module pack in accordance with claim 7, wherein said drive unit is configured to output a first phase to said first subset of stator modules and said additional drive unit is configured to output a second phase to said second subset of stator modules.

9. A stator for an axial flux electric machine, said stator comprising:

- a stator base; and
- a plurality of stator module packs attached to said stator base, each stator module pack of said plurality of stator module packs comprising:
 - a housing attached to said stator base;
 - a plurality of stator modules attached to said housing, each stator module comprising a core having at least one winding disposed thereon; and
 - a drive unit electrically connected to at least one stator module of said plurality of stator modules.

10. The stator in accordance with claim **9**, wherein said housing defines an enclosed volume, said plurality of stator modules and said drive unit are disposed within the enclosed volume.

11. The stator in accordance with claim **9**, wherein each drive unit is attached to said stator base proximate to and outside of said housing of a respective stator module pack of said plurality of stator module packs.

12. The stator in accordance with claim **9**, wherein said drive unit is electrically connected to all stator modules of said plurality of stator modules and configured to selectively couple electrical current to said plurality of stator modules.

13. The stator in accordance with claim **12**, said drive unit comprises a plurality of drive circuits, each drive circuit of said plurality of drive circuits coupled to a different subset of stator modules of said plurality of stator modules, wherein each subset of stator modules comprises less than all stator modules of said plurality of stator modules and no stator module is in more than one subset of stator modules.

14. The stator in accordance with claim **9**, wherein said drive unit is electrically connected to a first subset of stator modules of said plurality of stator modules, said first subset of stator modules comprising less than all stator modules of said plurality of stator modules, said drive unit configured to selectively couple power to said first subset of stator modules.

15. The stator in accordance with claim **14** further comprising an additional drive unit, said additional drive unit electrically connected to a second subset of stator modules of said plurality of stator modules, said second subset of stator modules comprising less than all stator modules of said plurality of stator modules, said second subset of stator modules comprising different stator modules than said first subset of stator modules, said additional drive unit configured to selectively couple electrical current to said second subset of stator modules.

16. The stator in accordance with claim **15**, wherein said drive unit is configured to output a first phase to said first subset of stator modules and said second drive unit is configured to output a second phase to said second subset of stator modules.

17. A three phase stator module pack for an axial flux electric machine, said stator module comprising:

- a housing configured for attachment to a stator base;
- a first subset of stator modules attached to said housing;
- a second subset of stator modules attached to said housing;
- a third subset of stator modules attached to said housing, each stator module of said first, second and third subsets of stator modules comprising a core having at least one winding disposed thereon; and
- a drive unit attached to said housing and electrically connected to said first subset of stator modules, said drive unit configured to selectively provide electrical current to said first subset of stator modules.

18. The three phase stator module pack in accordance with claim **17**, wherein said drive unit is coupled to said second subset of stator modules to provide electrical current to said second subset of stator modules and to said third subset of stator modules to provide electrical current to said third subset of stator modules.

19. The three phase stator module pack in accordance with claim **18**, wherein said drive unit comprises:

- a first drive circuit configured to selectively provide a first phase of electrical current to said first subset of stator modules;
- a second drive circuit configured to selectively provide a second phase of electrical current to said second subset of stator modules; and
- a third drive circuit configured to selectively provide a third phase of electrical current to said third subset of stator modules.

20. The three phase stator module pack in accordance with claim **17** further comprising:

- a second drive unit attached to said housing and electrically connected to said second subset of stator modules, said second drive unit configured to selectively provide electrical current to said second subset of stator modules; and
- a third drive unit attached to said housing and electrically connected to said third subset of stator modules, said third drive unit configured to selectively provide electrical current to said third subset of stator modules.

* * * * *