



US 20020057054A1

(19) **United States**

(12) **Patent Application Publication**

Chung et al.

(10) **Pub. No.: US 2002/0057054 A1**

(43) **Pub. Date: May 16, 2002**

(54) **ORGANIC ELECTROLUMINESCENT DISPLAY AND METHOD FOR MAKING SAME**

(30) **Foreign Application Priority Data**

Oct. 2, 2000 (TW)..... 89120490

(76) Inventors: **Chia-Tin Chung**, Miao Li (TW);
Su-Jen Chang, Bing Dong (TW);
Andrea Hwang, Zhang Hwa (TW);
Cheng-Ze Hu, Zhong Ho (TW)

Publication Classification

(51) **Int. Cl.⁷** **H01J 1/62**
(52) **U.S. Cl.** **313/506**

Correspondence Address:
Mitchell P Brook
Baker & McKenzie
101 West Broadway
Twelfth Floor
San Diego, CA 92101 (US)

(57) **ABSTRACT**

An organic electroluminescent display apparatus and method for manufacturing same is disclosed; the method prevents the anode and the cathode from defects and short circuit, and with the suitable geometry of the electrical insulation ramparts, the mechanical properties of the cathode insulating ramparts are increased such that the adhesion between the cathode insulating ramparts and the substrate is enhanced.

(21) Appl. No.: **09/731,314**

(22) Filed: **Dec. 5, 2000**

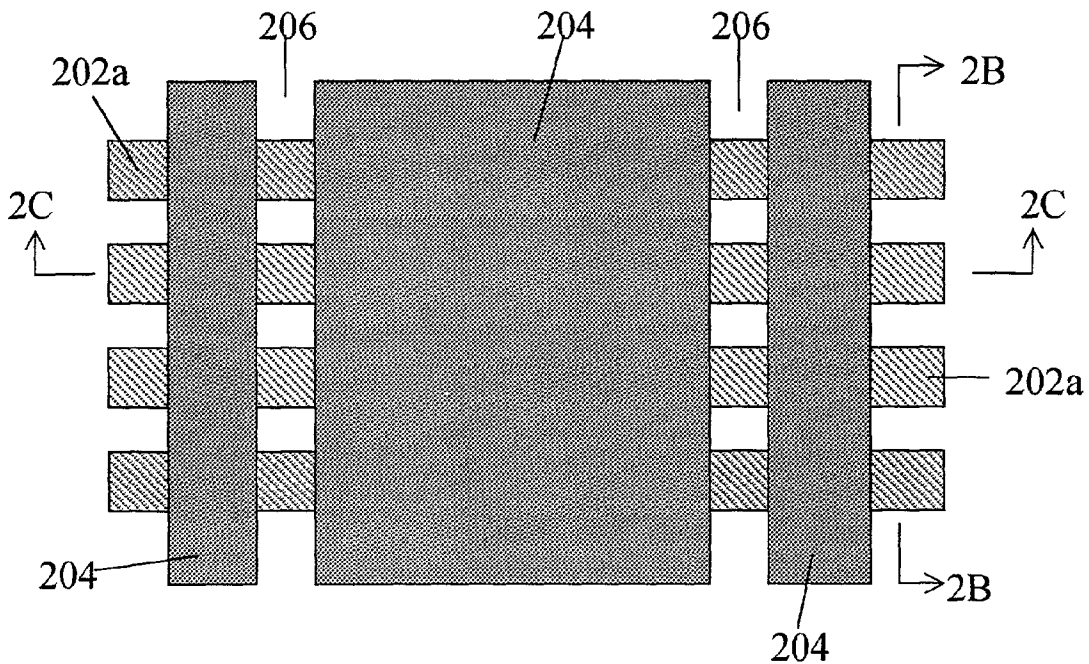

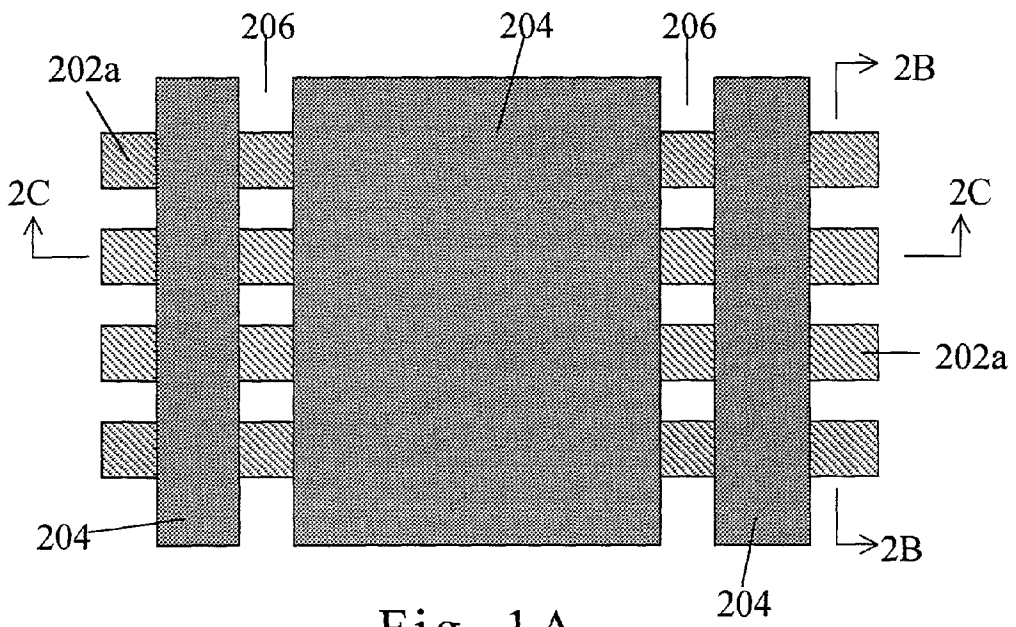

Fig. 1A

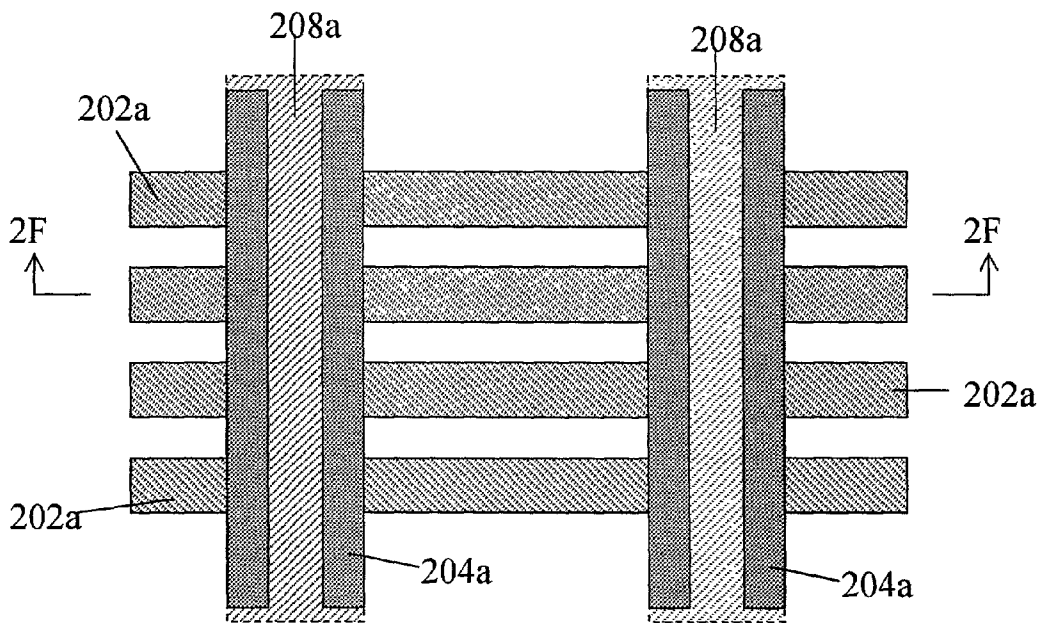

Fig. 1B



Fig. 2A

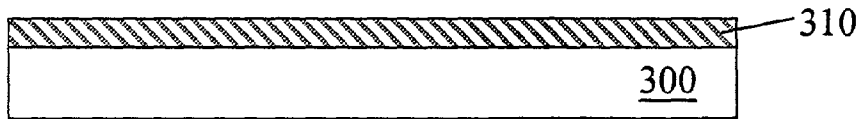

Fig. 2B



Fig. 2C

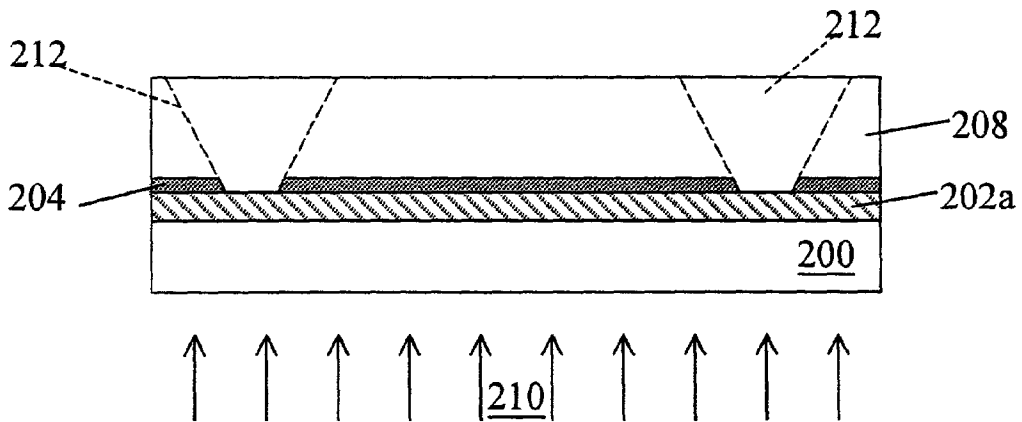

Fig. 2D

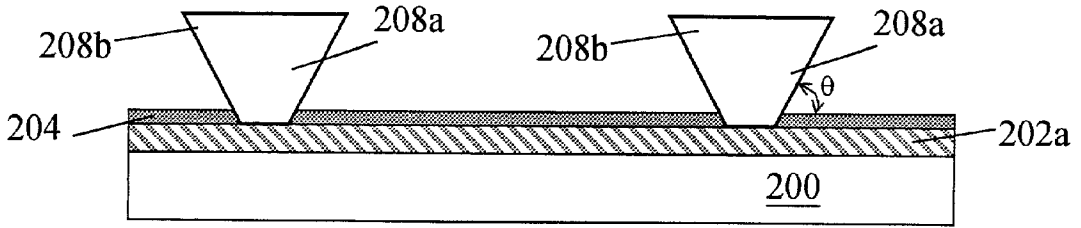

Fig. 2E

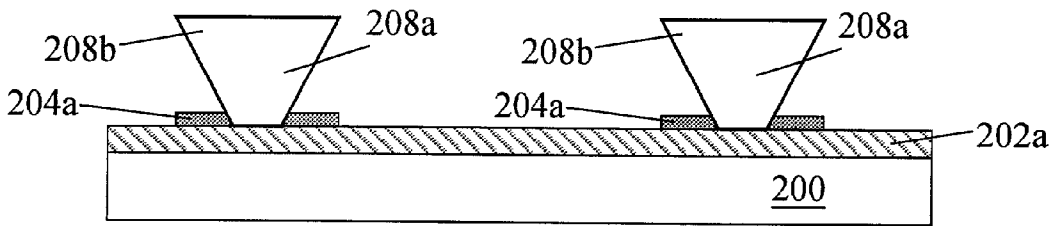

Fig. 2F

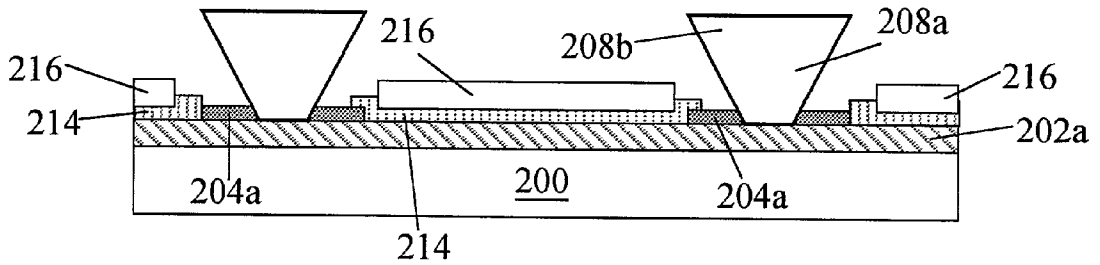

Fig. 2G

ORGANIC ELECTROLUMINESCENT DISPLAY AND METHOD FOR MAKING SAME

BACKGROUND OF THE INVENTION

[0001] 1. Field of the Invention

[0002] The present invention relates generally to organic electroluminescent displays, and more particularly to a structure of a cathode rampart of an organic electroluminescent display.

[0003] 2. Description of the Related Art

[0004] With the advent of the information technology age, there is an increasing demand for high-quality electro-optical displays, in which liquid crystal displays (LCD) are the most popular. A LCD backlight module comprising a light guide and a reflective plate is utilized for introducing the light beams, emitted from the cold cathode fluorescent lamp, vertically to the liquid crystal display panel, in which the liquid crystal contained therein controls the illuminance of the LCD. Conventional LCD has a limited view angle and requires very complicated manufacturing processes, which result in high manufacturing costs and relatively low yields. However, organic electroluminescent displays (OELD) have larger view angle and can be produced through less complex manufacturing process. These advantages are based on the self-luminance of the organic elements in the organic electroluminescent displays, which results in the unrestricted visual angles, more natural colors displayed, increased operational temperature range and shorter response time.

[0005] Organic electroluminescent displays generally include cathodes, organic electroluminescent materials and anodes, which are stacked in sequence on a substrate of glass. The cathodes and the anodes are respectively composed of a plurality of electrodes disposed in a parallel stripes formation, and the cathodes and anodes are configured perpendicular to each other. Organic electroluminescent materials are disposed at the intersections of the cathodes and the anodes, and are separated by insulating materials. Accordingly, the cathodes, the organic electroluminescent materials and the anodes form a three-layer structure disposed on the substrate. When a voltage difference between the cathodes and the anodes is present, the organic electroluminescent material emits light beams.

[0006] The metal electrodes of the cathodes are coated through evaporation on the organic electroluminescent material after the organic electroluminescent material and the insulating materials are formed. However, the cathodes composed of metal electrodes are easily diffused along the gaps between the organic electroluminescent material and the insulating materials during the formation step. Once the cathodes contact the anodes, it will short circuit and the organic electroluminescent materials between the cathodes and the anodes can not emit light.

[0007] If foreign particles fall aside the insulating materials as defects before the electrodes of the cathode are formed by coating through evaporation, metal materials will be formed around the foreign particles during the formation step and a short circuit is likely between neighboring metal electrodes.

[0008] Furthermore, during the manufacturing process of full-color organic electroluminescent displays (FOELD), it

is necessary to utilize shadow masks for partially masking the organic electroluminescent material. After the organic electroluminescent material layer for emitting light beams of one color is coated on the anodes, the shadow masks are moved so as to form another organic electroluminescent material layer for emitting light beams of another color. In this case, the shadow masks will contact the insulating materials directly during the formation of the second organic electroluminescent material layer. This will cause the insulating materials to be peeled off and deteriorate the organic electroluminescent material.

[0009] In the prior art, forming a plurality of cathode ramparts in the direction perpendicular to anode electrodes to separate cathode electrodes arranged in parallel from each other is disclosed. With the exposure at the side of the cathode ramparts, since the exposure is focused mostly at the upper portion of the cathode ramparts, the portion of the cathode ramparts adjacent to the anode electrodes is not of sufficiently cross-linking and consequently the mechanical performance thereof is not significantly high. This results in the cathode ramparts being easily peeled off while contacting the shadow masks due to the deterioration of the adhesion between the ramparts and the substrate.

[0010] If the adhesion between cathode ramparts and substrate is strengthened by revising the parameters in photolithography process, the geometry of the cathode ramparts can not be effectively used as a mask during the coating of the cathode electrodes through evaporation.

SUMMARY OF THE INVENTION

[0011] In view of the above problems, the principal object of the present invention is to provide an organic electroluminescent display and a method for manufacturing same, which prevents the anode and the cathode from defects and short circuit, and with the suitable geometry of the electrical insulation ramparts, the mechanical properties of the cathode insulating ramparts are increased such that the adhesion between the cathode insulating ramparts and the substrate is enhanced.

[0012] To achieve this object, the present invention provides an organic electroluminescent display, comprising a plurality of first display electrodes disposed in parallel on a substrate; a plurality of second display electrodes arranged in parallel, disposed on the first display electrodes and being perpendicular thereto; a plurality of organic electroluminescent materials disposed between the first display electrodes and the second display electrodes for emitting light and electrical insulation between the first and second display electrodes; a plurality of insulating ramparts disposed between neighboring two second display electrodes and arranged in parallel thereto; and overhangs disposed on the portion of the insulating ramparts away from the substrate, the portion of the insulating ramparts proximate to the substrate having a sufficiently high cross-linking such that better adhesion between insulating ramparts and the first display electrodes is ensured.

[0013] The present invention also provides a method for manufacturing an organic electroluminescent display, comprising the steps of forming a plurality of first display electrodes of high light transmission arranged in parallel on a transparent substrate; forming an insulating layer on the transparent substrate, the insulating layer including a plu-

rality of slots perpendicular to the first display electrodes for exposing the first display electrodes; forming cathode ramparts on the exposed first display electrodes, the portion of the cathode ramparts away from the substrate providing overhangs of greater width, and the portion of the cathode ramparts proximate to the substrate having sufficiently high cross-linking for increasing the adhesion between the cathode ramparts and the first display electrodes; removing the insulating layer partially by means of the masking effect of the overhangs of the cathode ramparts for exposing the first display electrode; forming an organic electroluminescent material on the exposed first display electrodes; and forming a plurality of second display electrodes on the organic electroluminescent material.

[0014] It should be noted that the step of forming the insulating ramparts may further comprise the steps of forming a blanket of photosensitive material on the insulating layer; illuminating the photosensitive material from one side of the substrate opposite to the first display electrodes with the insulating layer as photo masks; and proceeding a development process to the photosensitive material to expose the insulating layer. Since the light beams are from the side opposite to the first display electrodes, the cross-linking at the portion of the insulating ramparts proximate to the substrate is more significant than at the portion away from the substrate. Therefore, the adhesion between the ramparts and the substrate is enhanced.

[0015] The present invention further provides a method for manufacturing an organic electroluminescent display, comprising the steps of forming a plurality of first display electrodes of high light transmission on a transparent substrate; forming an opaque insulating layer on the transparent substrate, the opaque insulating layer including a plurality of slots at predetermined locations; forming a photosensitive insulating layer on the substrate; illuminating the photosensitive insulating layer from light beams passing through the substrate and the first display electrodes in sequence with the opaque insulating layer as photo masks; removing the unilluminated portion of the photosensitive insulating layer to form insulating ramparts; proceeding an anisotropic etching process to the opaque insulating layer for exposing the first display electrodes; forming an organic electroluminescent material on the exposed first display electrodes; and forming a plurality of second display electrodes on the organic electroluminescent material.

Additional advantages, objects and features of the present invention will become more apparent from the drawings and description which follows.

BRIEF DESCRIPTION OF THE DRAWINGS

[0016] The present invention will become more apparent from the detailed description given hereinbelow when read in conjunction with the accompanying drawings, which are given by means of illustration only and thus are not limitative of the present invention, in which:

[0017] FIGS. 1A and 1B are top views showing an organic electroluminescent display according to a preferred embodiment of the present invention; and

[0018] FIGS. 2A-2G are sectional views of an organic electroluminescent display according to the present invention illustrating the manufacture processes in sequence,

wherein FIGS. 2B, 2C are cross-sectional views taken along 2B-2B and 2C-2C of FIG. 1A respectively, and FIG. 2F is a cross-sectional view taken along 2F-2F of FIG. 1B.

Brief Description of the Reference Numerals	
200	substrate
202	transparent conductive material
202a	anode electrodes
204	opaque insulating material
206	opening
208	photosensitive insulating material
208a	cathode rampart
208b	overhang
210	light source for exposure
212	illuminated region
214	organic electroluminescent material
216	metal conductive material

DETAILED DESCRIPTION OF THE PREFERRED EMBODIMENT

[0019] With reference to FIG. 2A, a substantially transparent conductive material 202, such as indium tin oxide (ITO) or $\text{In}_2\text{O}_3\text{-ZnO}$, is first formed on a substrate 200, such as a transparent glass substrate or a flexible, light-transmitting plastic substrate, by a sputtering process. Next, photoresists are provided on the conductive material 202 as masks such that a plurality of anode electrodes 202a of transparent conductive material of stripe shapes arranged in parallel are formed from the conductive material 202 after a photolithography process for removing the portions of the conductive material 202 unmasked by the photoresists. Accordingly, the portions of the substrate 200 unmasked by the photoresists are exposed (see FIGS. 1A and 2B).

[0020] With reference to FIGS. 1A and 2C, a blanket of opaque insulating material, such as non-photosensitive polyimide doped with dark pigments, is spin-coated on the anode electrodes 202a about 1-2 μm thickness for covering both the anode electrodes 202a and the substrate 200 exposed. Then, a photolithography process or developers may be introduced to remove the opaque insulating material at predetermined locations so that the insulating material 204 of a pattern shown in FIG. 1A is defined and at least anode electrodes 202a are partially exposed. Slots 206 of stripe shapes parallel to each other and perpendicular to the direction of the anode electrodes 202a are therefore formed. Regions between two adjacent slots 206 functions as luminescent regions of the organic electroluminescent displays and the width of such regions is about 50-300 μm depending on the resolution of the organic electroluminescent displays. The width of the slots 206 is about 5-30 μm for forming cathode ramparts in later steps.

[0021] With reference to FIG. 2D, a blanket of photosensitive insulating materials 208 is formed on the insulating material 204 as negative photoresists and thereby filling the slots 206 and covering the substrate 200. The photosensitive insulating materials 208 can be, for example, spin-coated on the substrate about 3-5 μm thickness. Such negative photoresists are capable to be blanketed on the substrate 200 and the thickness thereof is not necessary to be significantly thick, so that the manufacturing cost can be conserved. Subsequently, a light source 210 for exposure is provided at

the side opposite to the photosensitive insulating materials **208**. The light beams **210** emitted from the light source can be parallel or not. Alternatively, an ultra-violet light source can be utilized to improve the baking effect for the photosensitive insulating material **208** and to reduce the cost.

[0022] The light beams **210** emitted from the light source penetrate into the substrate **200** and further pass through the anode electrodes **202a** and slots **206**. While the light beams **210** impinge the photosensitive insulating materials **208**, an exposure process is introduced thereto. Since the insulating material **204** is opaque, it functions as masks to resist the light beams from passing through, so that only light beams passing through the slots **206** impinge the photosensitive insulating materials **208** for exposure. Regions **212** between two corresponding divergent dotted lines indicate the regions of the photosensitive insulating material **208** illuminated by the light beams. It should be noted that the region **212** has a reverse-tapered cross-section due to the non-parallel light beams incident thereto. After removing the portion of the photosensitive insulating materials **208** not illuminated by the light beams with a developer solution, cathode ramparts **208a** of stripe shapes arranged substantially in parallel are formed (see FIGS. 2E and 1B). At this stage, infrared rays or other heat source can be utilized for baking the cathode ramparts **208a** to enhance the structural stability.

[0023] Since the opaque insulating materials **208** are formed on the substrate **200**, the step of forming cathode ramparts by photo masks through exposure from the side of the photosensitive insulating materials **208** in the prior art can be omitted. In addition, while the substrate **200** is flexible, such as a transparent flexible plastic substrate, the opaque insulating materials **208** will be bent corresponding to the substrate **200**, so that the alignment between the photo masks and the substrate can be ensured and the exposure effect will not be affected by the flexibility of the substrate.

[0024] In the above mentioned exposure process, since the portion of the cathode ramparts **208a** proximate to the substrate **200** receives more energy from the light beams than the portion away from the substrate **200**, more photo initiators within the photosensitive insulating material **208** proceed cross-linking adjacent to the slots **206**. Therefore, the cross-linking effect at the portion of the cathode ramparts **208a** proximate to the substrate **200** is more significant than at the portion far from the substrate **200**, whereby the adhesion between the cathode ramparts **208a** and the substrate **200** is enhanced for preventing the cathode ramparts **208a** from peeling off.

[0025] Since the light beams from the light source **210** are not limited to be in parallel, the shape of the cathode ramparts **208a** corresponds to the region illuminated by light beams and will be a reverse-tapered cross-sectional configuration in which overhangs **208b** of greater width are formed at the portion of the cathode ramparts **208a** far from the substrate **200**. Therefore, the angle θ between the substrate **200** and the outer circumference of the cathode ramparts **208a** is less than 80 degrees, preferably in a range of 40-80 degrees due to the non-parallel light beams incident to the cathode ramparts **208a** and the insulating materials **204** as optical gratings. Since the angle θ according to the present invention is smaller than that in the prior art, the height of

the cathode ramparts **208a** of the present invention can be reduced to 1-5 μ m for implementing the same masking effect as in the art.

[0026] With reference to FIGS. 2F and 1B, after the overhangs **208b** of the cathode ramparts **208a** are formed, an anisotropic etching process, such as a reactive-ion etching (RIE) or plasma etching, is conducted to the opaque insulating materials **204**. With the masking effect of the overhangs **208b**, the resultant insulating materials **204a** are substantially parallel to the cathode rampart layers **208a** and are substantially perpendicular to the anode electrodes **202a**, thereby exposing partially the anode electrodes **202a** (see FIG. 1B).

[0027] Next, organic electroluminescent materials **214** are formed on the exposed anode electrodes **202a** (see FIG. 2G). While producing single-color organic electroluminescent displays, an organic electroluminescent layer is coated through evaporation on the exposed anode electrodes **202a**. While producing full-color organic electroluminescent displays, RGB organic electroluminescent layers are formed in turn on the exposed anode electrodes **202a** by using shadow masks. Subsequently, metal conductive materials **216**, such as Al, Mg-Al alloy or other suitable metal materials, are formed on the organic electroluminescent materials **214** as cathode electrodes of the organic electroluminescent displays.

[0028] With reference to FIG. 2G, metal conductive materials **216** are formed on the organic electroluminescent materials **214** without damaging the metal conductive materials **216** due to the masking effect of the overhangs **208b** of the cathode ramparts **208a**. In addition, the short circuit between the metal conductive materials **216** and the anode electrodes **202a** is avoided due to the presence of the cathode ramparts **208a** and the insulating materials **204a**.

[0029] According to the present invention, adhesions between the cathode ramparts and the substrate and between the cathode ramparts and the transparent conductive materials are enhanced such that the shadow masks will not be damaged while coating organic electroluminescent materials through evaporation. In addition, since the cathode ramparts are formed through exposure from the side opposite to the photosensitive insulating materials, and better masking effect can be achieved by means of the small angle between the substrate and the cathode ramparts according to the present invention, thick photosensitive materials, light sources emitting parallel light beams and providing additional one photo mask are not necessary such that the manufacturing cost can be significantly reduced.

[0030] Although the preferred embodiments of the present invention have been disclosed for illustrative purposes, those skilled in the art will appreciate that various modifications, additions and substitutions are possible, without departing from the scope and spirit of the present invention as recited in the accompanying claims.

What is claimed is:

1. A method for manufacturing an organic electroluminescent display, comprising the steps of:

forming a plurality of first display electrodes arranged in parallel on a substantially transparent substrate;

- forming an insulating layer on the transparent substrate, the insulating layer including a plurality of slots perpendicular to the first display electrodes for exposing the first display electrodes;
- forming insulating ramparts on the exposed first display electrodes, the portion of the insulating ramparts away from the substrate further forming overhangs, and the portion of the cathode ramparts proximate to the substrate having sufficiently high cross-linking for increasing the adhesion between the insulating ramparts and the first display electrodes;
- partially removing the insulating layer through the masking effect of the overhangs for exposing the first display electrode;
- forming an organic electroluminescent material on the exposed first display electrodes; and
- forming a plurality of second display electrodes on the organic electroluminescent material.
2. The method according to claim 1, wherein the thickness of the insulating ramparts is in a range of 1-5 μm .
3. The method according to claim 1, wherein the angle between the substrate and each overhang is in a range of 40-80 degrees.
4. The method according to claim 1, wherein the step of forming the insulating ramparts further comprises the steps of:
- forming a blanket of photosensitive material on the insulating layer;
- illuminating the photosensitive material from one side of the substrate opposite to the first display electrodes with the insulating layer as photo masks; and
- processing the photosensitive material to expose the insulating layer.
5. The method according to claim 1, wherein the step of partially removing the insulating layer by means of the masking effect of the overhangs is achieved by an anisotropic etching process.
6. The method according to claim 1, wherein the cross-linking at the portion of the insulating ramparts proximate to the substrate is stronger than at the portion away from the substrate.
7. A method for manufacturing an organic electroluminescent display, comprising the steps of:
- forming a plurality of first display electrodes of high light transmission on a substantially transparent substrate;
- forming a substantially opaque insulating layer on the transparent substrate;
- forming a plurality of slots at predetermined locations on the opaque insulating layer;
- forming a photosensitive insulating layer on the substrate;
- illuminating the photosensitive insulating layer from light beams passing through the substrate and the first display electrodes in sequence with the opaque insulating layer as photo masks;
- removing the un-illuminated portion of the photosensitive insulating layer to form insulating ramparts;
- proceeding an anisotropic etching process to the opaque insulating layer for exposing the first display electrodes;
- forming an organic electroluminescent material on the exposed first display electrodes; and
- forming a plurality of second display electrodes on the organic electroluminescent material.
8. The method according to claim 7, wherein the thickness of the insulating ramparts is in a range of 1-5 μm .
9. The method according to claim 7, wherein overhangs are on the portion of the insulating ramparts away from the substrate, and the portion of the insulating ramparts proximate to the substrate having a sufficiently high cross-linking for enhancing the adhesion between insulating ramparts and the first display electrodes.
10. The method according to claim 9, wherein the angle between the substrate and each overhang is in a range of 40-80 degrees.
11. The method according to claim 7, wherein the cross-linking at the portion of the insulating ramparts proximate to the substrate is more significant than at the portion away from the substrate.
12. An organic electroluminescent display, comprising:
- a plurality of first display electrodes of high light transmission formed in parallel on a substantially transparent substrate;
- an opaque insulating layer having slots of stripe shapes formed on the first display electrodes, the slots are perpendicular to the first display electrodes;
- a plurality of insulating ramparts of reverse-tapered cross-section formed on first display electrodes at the slots, the insulating ramparts including overhangs on the portion away from the substrate such that the insulating layer is formed utilizing an anisotropic etching process so as to be in parallel to the insulating ramparts and the first display electrodes are exposed partially;
- an organic electroluminescent material disposed on the exposed first display electrodes; and
- a plurality of second display electrodes formed in parallel on the organic electroluminescent material, the second display electrodes being perpendicular to the first display electrodes.
13. The organic electroluminescent display according to claim 12, wherein the angle between the substrate and each overhang is in a range of 40-80 degrees.
14. The organic electroluminescent display according to claim 12, wherein the thickness of the insulating ramparts is in a range of 1-5 μm .
15. The organic electroluminescent display according to claim 12, wherein the cross-linking at the portion of the insulating ramparts proximate to the substrate is more significant than at the portion away from the substrate.