



(12) **United States Patent**
Mantor et al.

(10) **Patent No.:** **US 11,954,782 B2**
(45) **Date of Patent:** ***Apr. 9, 2024**

(54) **HYBRID RENDER WITH PREFERRED PRIMITIVE BATCH BINNING AND SORTING**

(58) **Field of Classification Search**
CPC G06T 15/005; G06T 15/04
See application file for complete search history.

(71) Applicants: **Advanced Micro Devices, Inc.**, Santa Clara, CA (US); **ATI Technologies ULC**, Markham (CA)

(56) **References Cited**

U.S. PATENT DOCUMENTS

5,251,296 A 10/1993 Rhoden et al.
5,371,519 A 12/1994 Fisher
(Continued)

(72) Inventors: **Michael Mantor**, Orlando, FL (US); **Laurent Lefebvre**, Markham (CA); **Mikko Alho**, Kokemaki (FI); **Mika Tuomi**, Noormarkku (FI); **Kiia Kallio**, Inkoo As (FI)

FOREIGN PATENT DOCUMENTS

(73) Assignees: **Advanced Micro Devices, Inc.**, Santa Clara, CA (US); **ATI Technologies ULC**, Ontario (CA)

CN 101794456 A 8/2010
CN 103824276 A 5/2014
(Continued)

(*) Notice: Subject to any disclaimer, the term of this patent is extended or adjusted under 35 U.S.C. 154(b) by 0 days.

This patent is subject to a terminal disclaimer.

OTHER PUBLICATIONS

Primitive Batch Binner (PBB) Block Specification, Mar. 2015, 269 pgs., Siru Innovations Oy, Pori, FI.

Primary Examiner — Terrell M Robinson

(74) *Attorney, Agent, or Firm* — Volpe Koenig

(21) Appl. No.: **17/208,730**

(22) Filed: **Mar. 22, 2021**

(57) **ABSTRACT**

(65) **Prior Publication Data**

US 2021/0209831 A1 Jul. 8, 2021

A method, system, and non-transitory computer readable storage medium for rasterizing primitives are disclosed. The method, system, and non-transitory computer readable storage medium includes: generating a primitive batch from a sequence of one or more primitives, wherein the primitive batch includes primitives sorted into one or more row groups based on which row of a plurality of rows each primitive intersects; and processing each row group, the processing for each row group including: identifying one or more primitive column intercepts for each of the one or more primitives in the row group, wherein each combination of primitive column intercept and row identifies a bin; and rasterizing the one or more primitives that intersect the bin.

Related U.S. Application Data

(63) Continuation of application No. 15/250,357, filed on Aug. 29, 2016, now Pat. No. 10,957,094, which is a (Continued)

(51) **Int. Cl.**
G06T 15/00 (2011.01)
G06T 15/04 (2011.01)

(52) **U.S. Cl.**
CPC **G06T 15/005** (2013.01); **G06T 15/04** (2013.01)

20 Claims, 11 Drawing Sheets

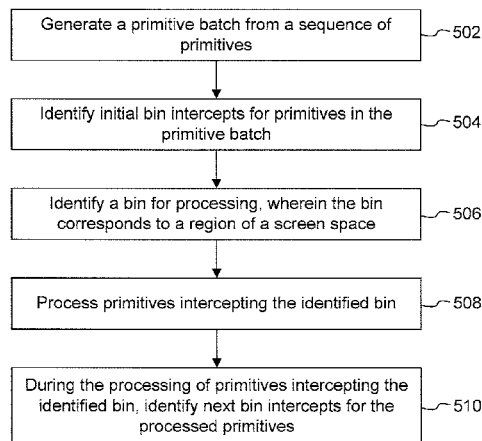

Related U.S. Application Data

continuation-in-part of application No. 13/853,422,
filed on Mar. 29, 2013, now Pat. No. 10,169,906.

(56)

References Cited

U.S. PATENT DOCUMENTS

5,533,170 A * 7/1996 Teitzel G06T 11/203
358/1.8
5,886,701 A 3/1999 Chauvin et al.
6,058,405 A * 5/2000 Kolte G06T 5/20
382/262
6,222,550 B1 4/2001 Rosman et al.
6,344,852 B1 2/2002 Zhu et al.
6,437,780 B1 8/2002 Baltaretu et al.
6,784,884 B1 8/2004 Hsieh
6,798,421 B2 * 9/2004 Baldwin G06T 1/20
345/501
7,170,515 B1 1/2007 Zhu
7,222,364 B2 5/2007 Vue et al.
8,502,829 B2 8/2013 Howson
8,704,836 B1 4/2014 Rhoades et al.
8,970,584 B1 3/2015 Aila et al.
9,098,943 B1 8/2015 Baldwin
2003/0043171 A1 3/2003 Fliflet
2003/0058244 A1 3/2003 Ramani et al.
2003/0122815 A1 7/2003 Deering
2003/0122819 A1 * 7/2003 Koneru G06T 11/40
345/620
2003/0122833 A1 7/2003 Doyle
2003/0174133 A1 9/2003 Shehane et al.
2004/0183807 A1 9/2004 Emberling et al.
2004/0196283 A1 10/2004 Lewis et al.
2004/0196285 A1 10/2004 Rice et al.
2007/0018988 A1 * 1/2007 Guthe G06T 11/20
345/441
2007/0146378 A1 6/2007 Sorgard et al.
2007/0165035 A1 7/2007 Duluk, Jr. et al.

2007/0296725 A1 12/2007 Steiner et al.
2008/0259076 A1 10/2008 Meidns
2010/0177105 A1 7/2010 Nystad et al.
2011/0148901 A1 6/2011 Adams et al.
2011/0216069 A1 9/2011 Keall et al.
2012/0081370 A1 * 4/2012 Min G06T 15/80
345/426
2012/0280992 A1 11/2012 Shebanow et al.
2013/0002663 A1 1/2013 Howson
2013/0113799 A1 5/2013 Woo et al.
2013/0229414 A1 9/2013 Gruber
2013/0237187 A1 9/2013 Park et al.
2013/0271465 A1 10/2013 Clarberg et al.
2013/0293544 A1 11/2013 Schreyer et al.
2014/0071150 A1 * 3/2014 Fishwick G06T 1/20
345/589
2014/0118364 A1 5/2014 Hakura et al.
2014/0118380 A1 5/2014 Hakura et al.
2014/0139534 A1 5/2014 Tapply et al.
2014/0196285 A1 7/2014 Chao et al.
2014/0267259 A1 9/2014 Frascati et al.
2014/0292756 A1 10/2014 Mantor et al.
2014/0347357 A1 * 11/2014 Kim G06T 11/40
345/420
2014/0354682 A1 12/2014 Heggelund et al.
2015/0097857 A1 4/2015 Akenine-Moller et al.
2015/0145873 A1 5/2015 Akenine-Moller et al.
2015/0170407 A1 6/2015 Redshaw
2015/0302545 A1 10/2015 Harris et al.
2015/0325037 A1 11/2015 Lentz et al.
2017/0213313 A1 7/2017 Hakura et al.

FOREIGN PATENT DOCUMENTS

CN 105139330 A 12/2015
JP 2003-515798 T2 5/2003
JP 2008-520021 T2 6/2008
WO 2001/37220 A1 5/2001

* cited by examiner

100

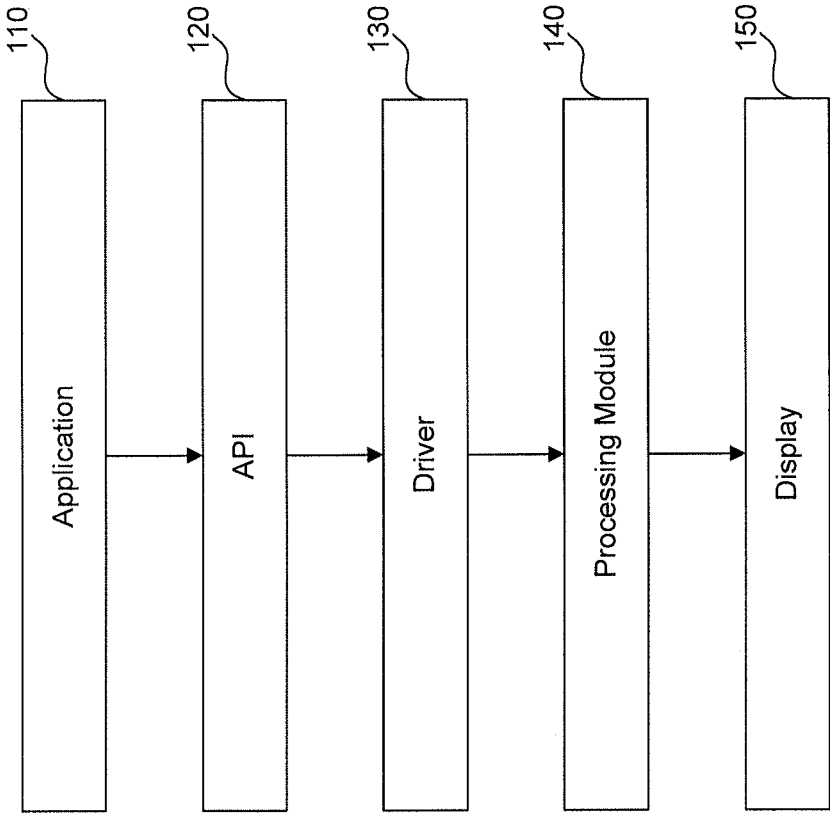

FIG. 1

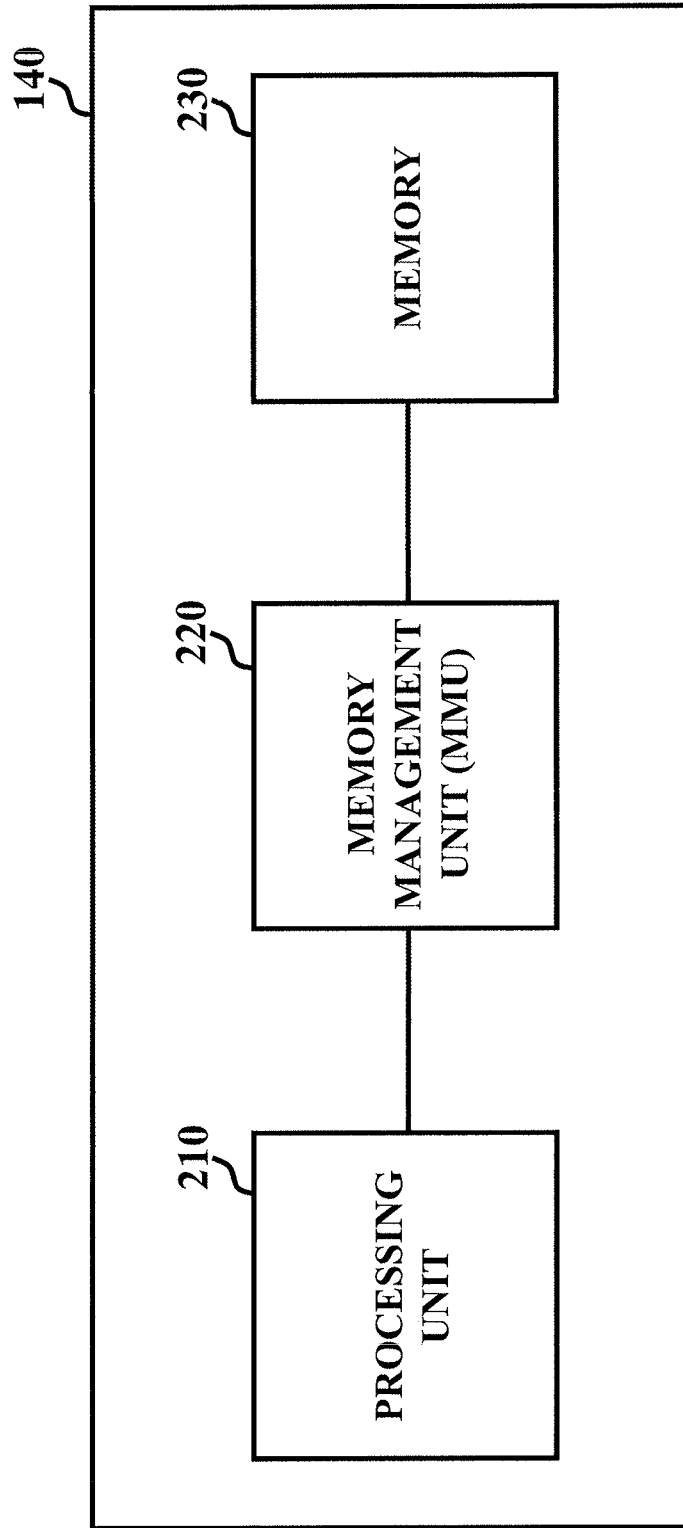

FIG. 2

300

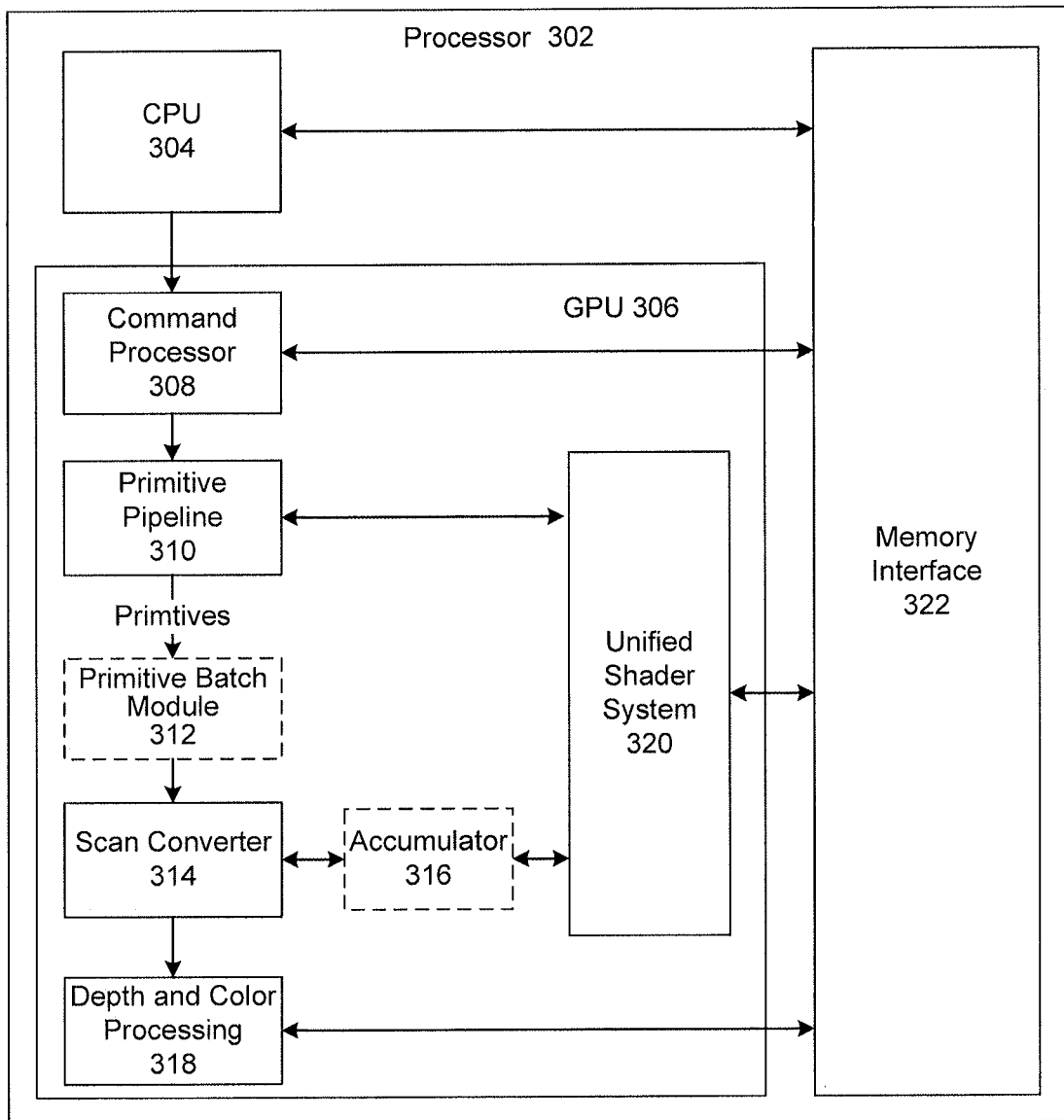

FIG. 3

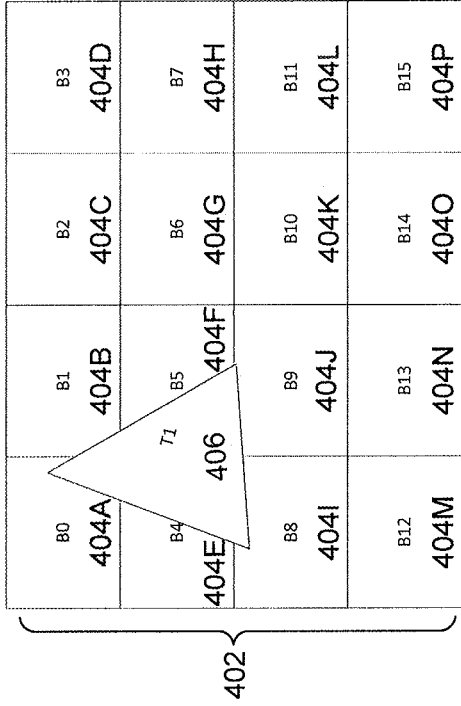

FIG. 4B

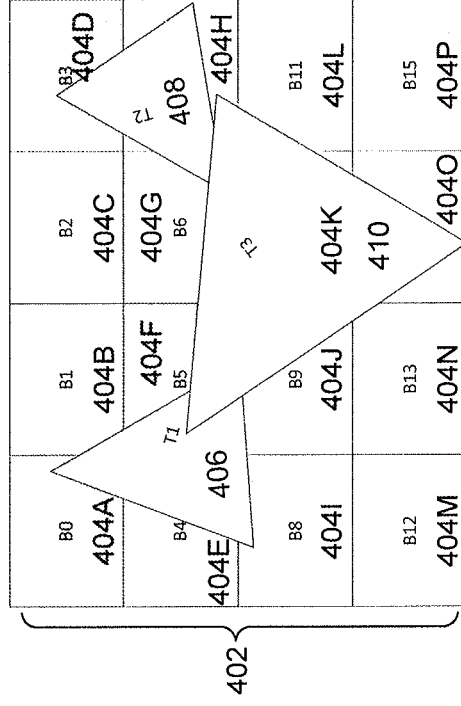

FIG. 4D

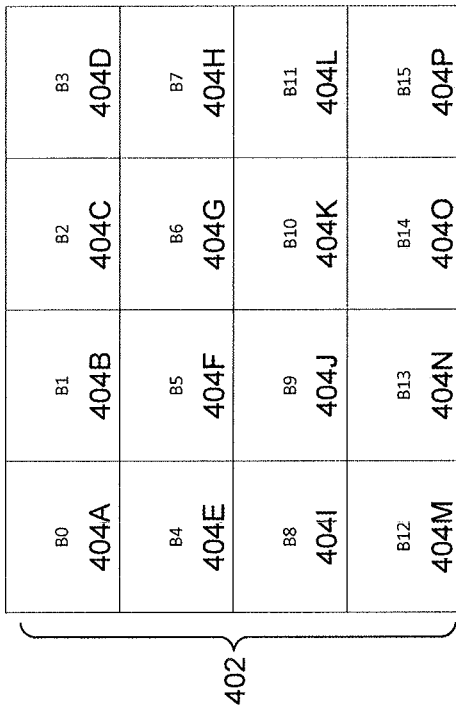

FIG. 4A

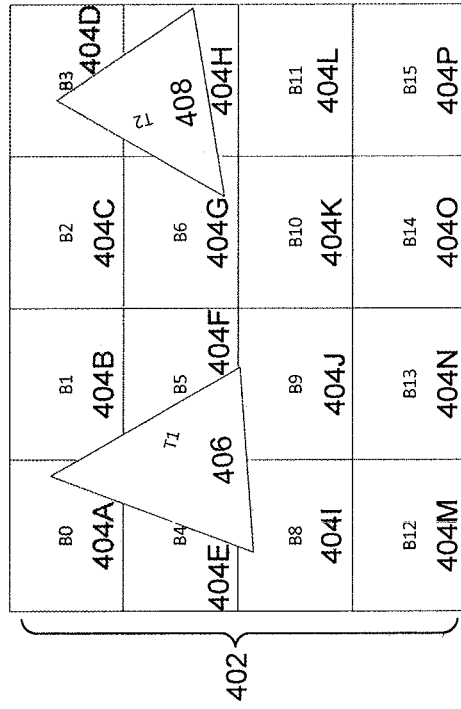

FIG. 4C

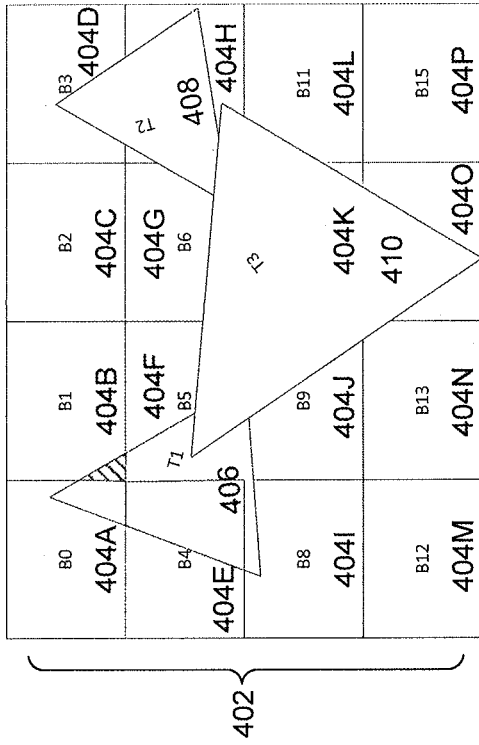

FIG. 4E

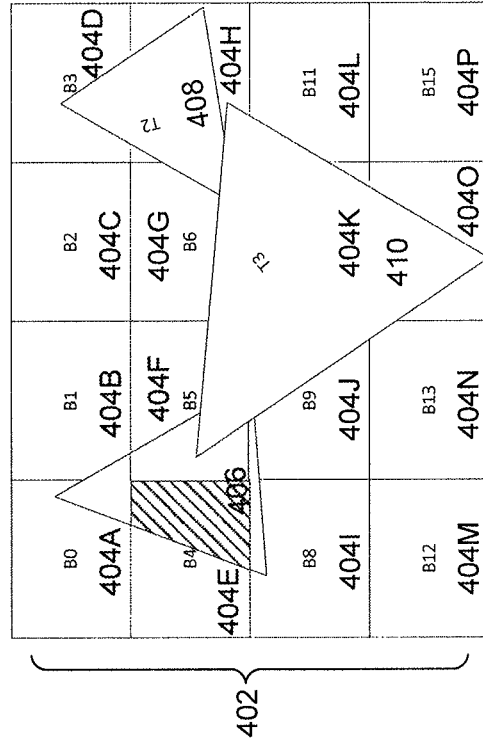

FIG. 4F

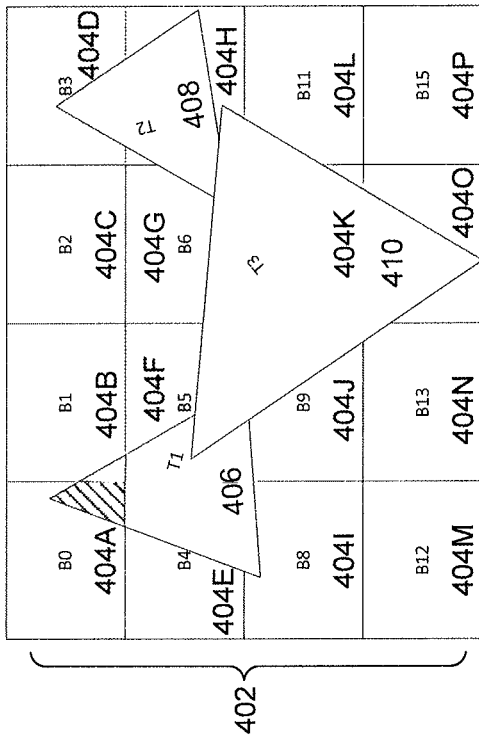

FIG. 4G

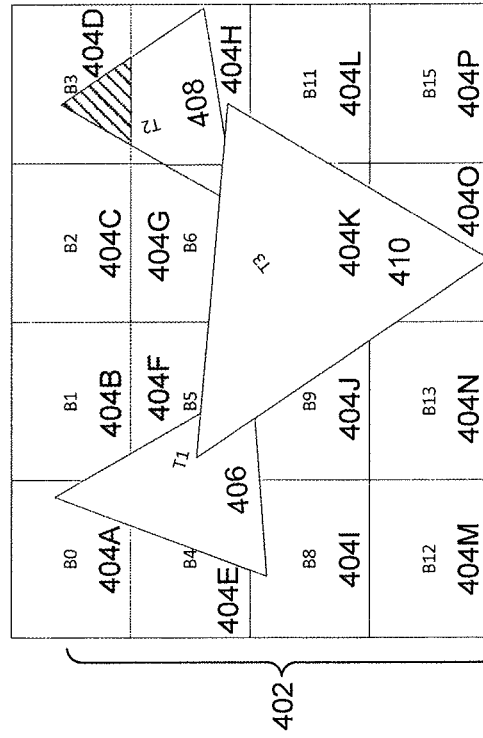

FIG. 4H

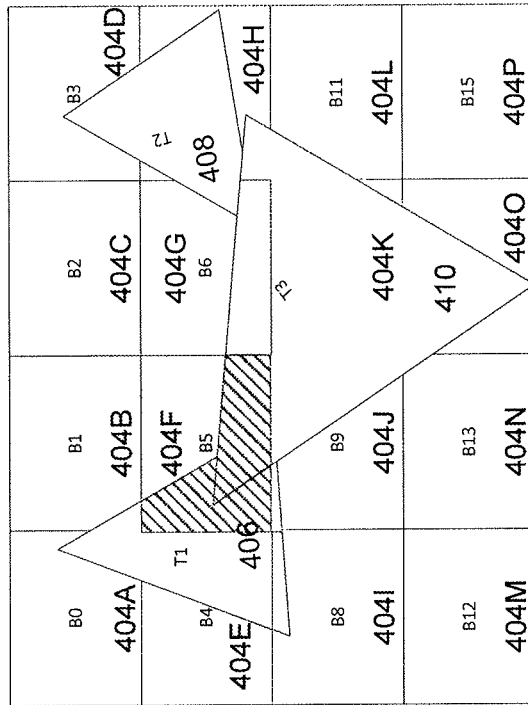

FIG. 4I

500

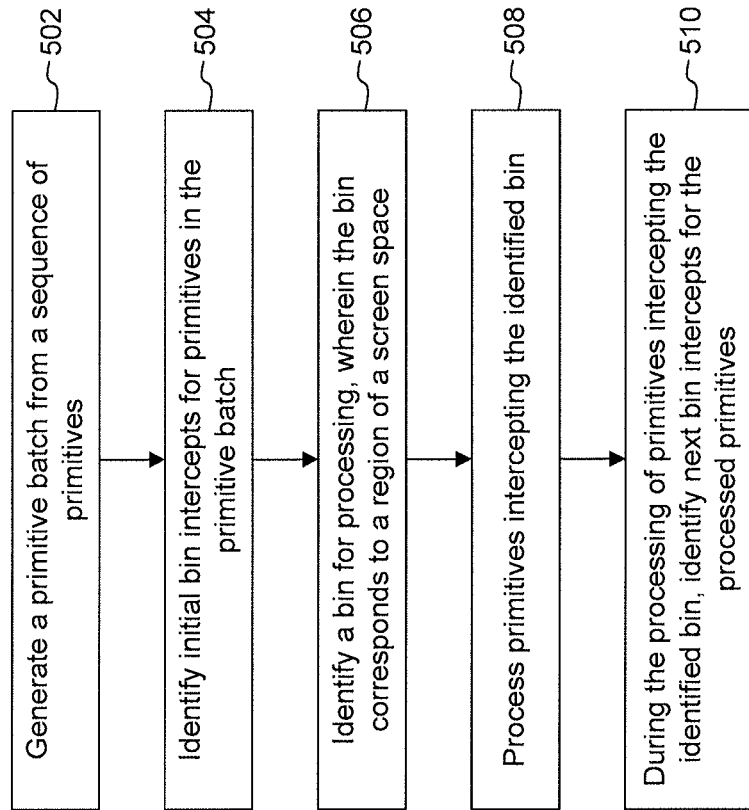

FIG. 5

600

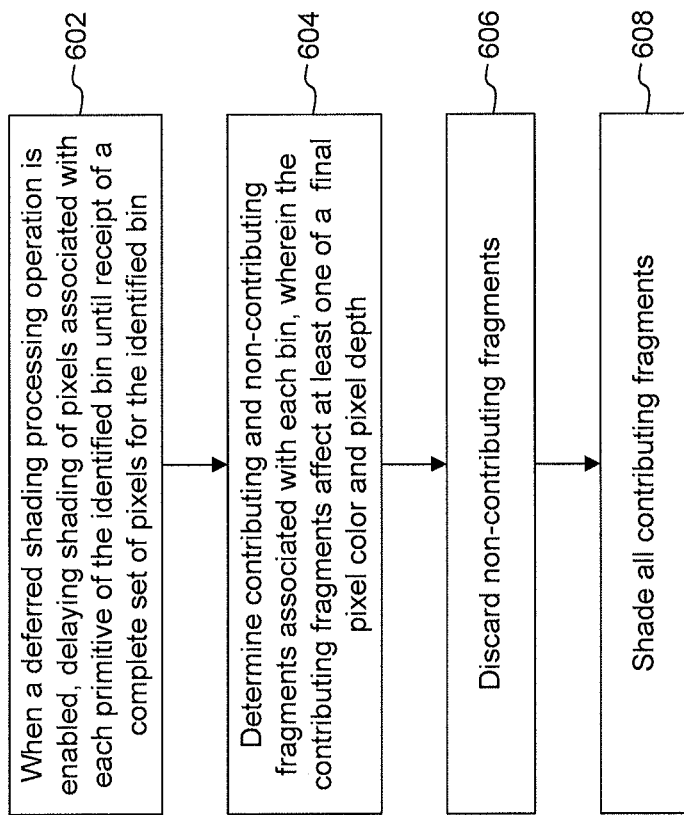

FIG. 6

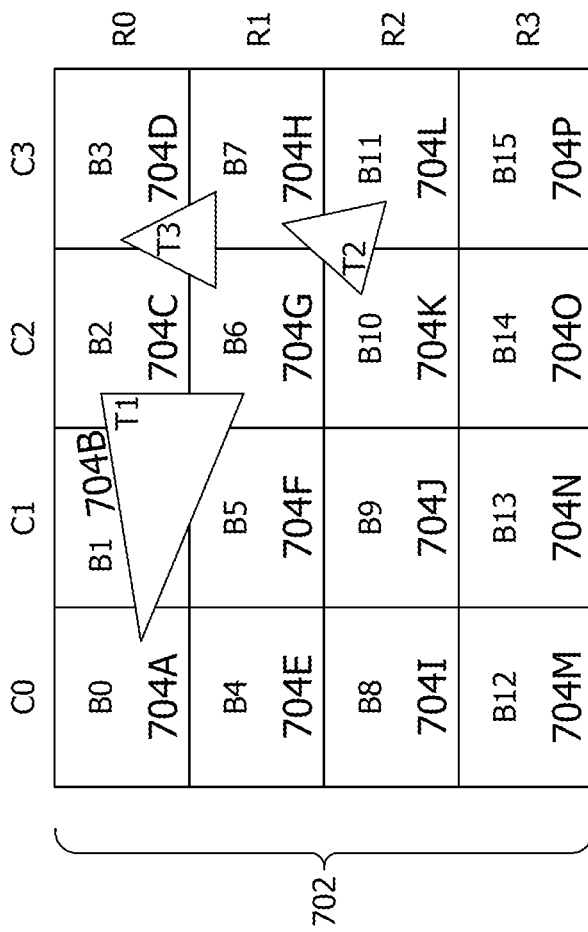

FIG. 7

800

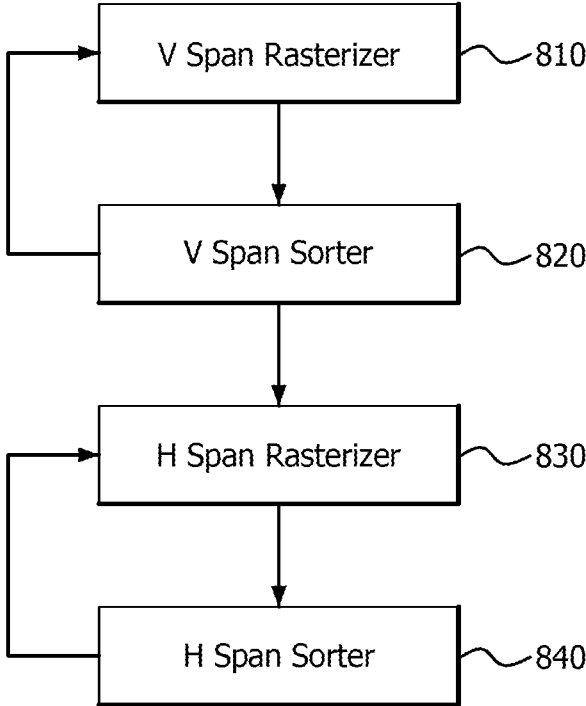
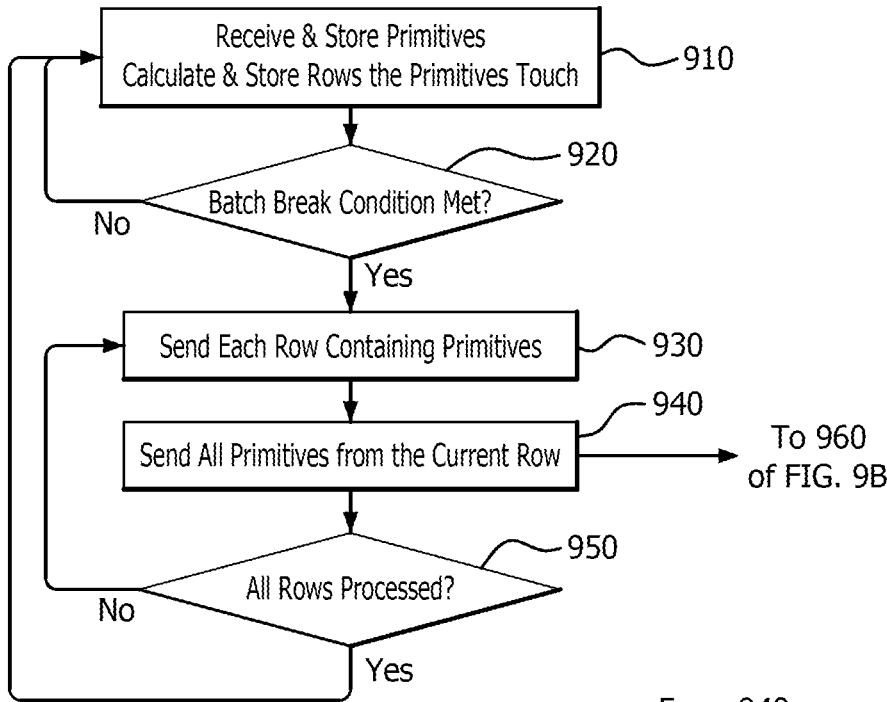

FIG. 8

900A FIG. 9A



From 940
of FIG. 9A

900B

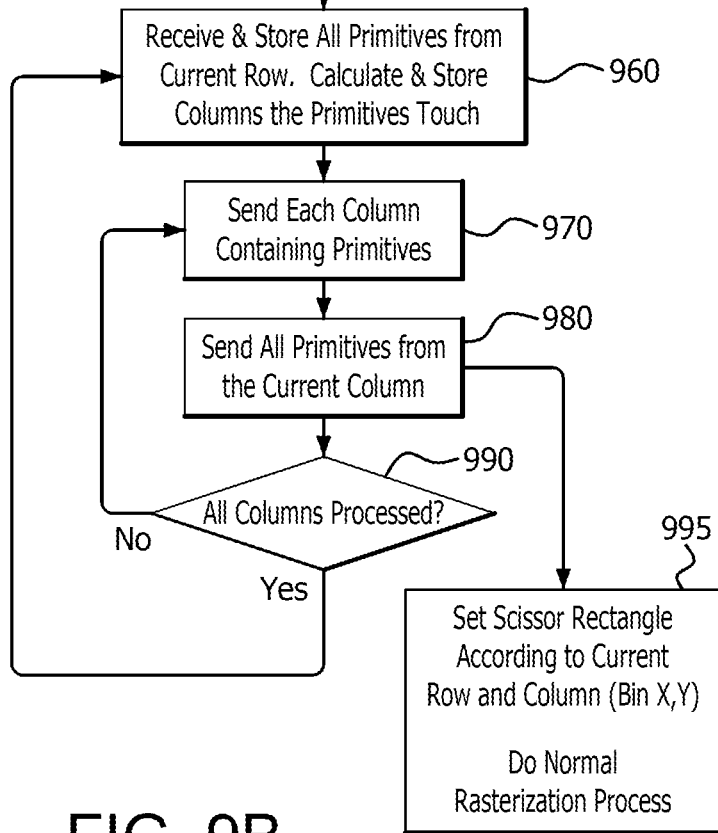

FIG. 9B

HYBRID RENDER WITH PREFERRED PRIMITIVE BATCH BINNING AND SORTING

CROSS REFERENCE TO RELATED APPLICATIONS

This application is a continuation of U.S. patent application Ser. No. 15/250,357, filed Aug. 29, 2016, which is a continuation-in-part of U.S. patent application Ser. No. 13/853,422, filed on Mar. 29, 2013, which issued on Jan. 1, 2019 as U.S. Pat. No. 10,169,906, the contents of which are incorporated by reference as if fully set forth. This application is related to co-pending U.S. patent application Ser. No. 16/179,376, filed Nov. 2, 2018.

BACKGROUND

Display images typically comprise millions of dots, where each dot represents one of thousands or millions of colors. These dots are known as picture elements, or “pixels”. Each pixel has multiple attributes associated with it, such as, color, depth, translucency, or texture attributes. Those attributes are manipulated and processed before being rendered on a display screen of an electronic device.

Pixels are produced by rendering graphical objects in order to determine color values for respective pixels. Example graphical objects include points, lines, polygons, and three-dimensional (3D) higher order surfaces. Points, lines, and polygons represent rendering primitives which are the basis for most 3D rendering instructions. More complex structures, such as 3D objects, are formed from a combination or a mesh of such primitives. To display a particular scene, the primitives with potential contributing pixels associated with the scene are rendered individually by determining pixels that fall within the edges of the primitives, and obtaining the attributes of the primitives that correspond to each of those pixels.

Because there are often thousands, millions, or even hundred millions of primitives in a 3D scene, the complete rasterization of each primitive individually can result in less than optimal system performance while rendering complex 3D images on a display screen. Such conventional graphics systems suffer from repeated color and depth value reads and writes from memory as the rasterization process moves from one primitive to the next. Immediate shading of rasterized pixels can result in unnecessary processing overhead and overall inefficient use of system memory bandwidth.

BRIEF SUMMARY OF EMBODIMENTS

Embodiments are generally directed to processing in a graphics pipeline. More particularly, embodiments are directed to a deferred primitive batch binning mechanism for rendering graphics in a graphics pipeline.

A system, method and a computer program product are provided for rendering graphics with deferred primitive batch binning. A primitive batch is generated from a sequential sequence of primitives. A first bin intercept is identified for primitives as they arrive in the primitive batch. After a batch is closed, a first bin for processing is identified. The bin corresponds to a region of a screen space. Primitives intercepting the identified bin are processed. For each primitive intercepting the identified bin, a next bin intercept is identified and the pixels included in the primitive that are enclosed by the identified bin are sent for detailed rasterization. The process is repeated for any bins intersected by

a primitive of the primitive batch. Further features and advantages of the disclosed embodiments, as well as the structure and operation of various embodiments, are described in detail below with reference to the accompanying drawings. It is noted that the disclosure is not limited to the specific embodiments described herein. Such embodiments are presented herein for illustrative purposes only. Additional embodiments will be apparent to persons skilled in the relevant art(s) based on the teachings contained herein.

BRIEF DESCRIPTION OF THE DRAWINGS/FIGURES

The accompanying drawings, which are incorporated herein and form part of the specification, illustrate the present disclosure and, together with the description, further serve to explain the principles of the embodiments and to enable a person skilled in the pertinent art to make and use the embodiments. Various embodiments are described below with reference to the drawings, wherein like reference numerals are used to refer to like elements throughout.

FIG. 1 is a block diagram of a graphics processing system, according to an embodiment.

FIG. 2 is a block diagram of a processing module, according to an embodiment.

FIG. 3 is a block diagram of an immediate mode rendering system, according to an embodiment.

FIGS. 4A-4I illustrate examples of a deferred primitive batch binning process, according to an embodiment.

FIG. 5 is a flowchart illustrating a process for deferred primitive batch binning, according to an embodiment.

FIG. 6 is flowchart illustrating a delayed shading process, according to an embodiment.

FIG. 7 illustrates an example of batch binning and sorting in an immediate mode rendering system, according to an embodiment.

FIG. 8 is an example schematic representation of a system for performing batch binning and sorting, according to an embodiment.

FIGS. 9A-9B depict a flow diagram of an example method for performing batch binning and sorting, according to an embodiment.

Embodiments will be described with reference to the accompanying drawings. Generally, the drawing in which an element first appears is typically indicated by the leftmost digit(s) in the corresponding reference number.

DETAILED DESCRIPTION OF EMBODIMENTS

In the detailed description that follows, references to “one embodiment,” “an embodiment,” “an example embodiment,” etc., indicate that the embodiment described may include a particular feature, structure, or characteristic, but every embodiment may not necessarily include the particular feature, structure, or characteristic. Moreover, such phrases are not necessarily referring to the same embodiment. Further, when a particular feature, structure, or characteristic is described in connection with an embodiment, it is submitted that it is within the knowledge of one skilled in the art to affect such feature, structure, or characteristic in connection with other embodiments whether or not explicitly described.

The term “embodiments” does not require that all embodiments include the discussed feature, advantage or mode of operation. Alternate embodiments may be devised without departing from the scope of the disclosure, and

well-known elements may not be described in detail or may be omitted so as not to obscure the relevant details. In addition, the terminology used herein is for the purpose of describing particular embodiments only and is not intended to be limiting. For example, as used herein, the singular forms “a,” “an” and “the” are intended to include the plural forms as well, unless the context clearly indicates otherwise. It will be further understood that the terms “comprises,” “comprising,” “includes” and/or “including,” when used herein, specify the presence of stated features, integers, steps, operations, elements, and/or components, but do not preclude the presence or addition of one or more other features, integers, steps, operations, elements, components, and/or groups thereof.

To render and process data efficiently, graphics processing units (GPUs) include hardware pipelines. Hardware pipelines are dedicated to processing data of a particular type or perform a particular type of a function. A graphics pipeline is dedicated to process and render 3D computer graphics, images, video, etc. Each image or a frame is rendered using primitives that include points, lines, polygons or a combination of primitives that are organized into a mesh. The primitives in each frame or image are drawn individually by determining which pixels fall within the edges of the primitives and calculating the attributes of the primitive that corresponds to each of those pixels.

In conventional immediate mode rendering systems, a graphics processing pipeline is configured to render each primitive in a scene in the order the primitives were received by the pipeline. For example, a primitive can include a set of attributes such as x, y and z coordinates, color, or texture u, v coordinates corresponding to vertices of the primitive. Every forward facing primitive in a scene is then rasterized and shaded (the process of shading in contemporary GPU conducts user described operations to include interpolation, texturing, lighting and combining operations). Conventional immediate mode rendering graphics pipelines suffer from repeated color and depth value reads from memory as the rasterization process moves from one primitive to the next. For example, when the spatial separation of fragments associated with primitives on the screen exceeds the capacity of on chip color and depth read/write caches, repeated trips to system memory are required in order to process the primitives appropriately. This drawback in primitive processing significantly slows the rendering of an image in the graphics pipeline and is a bottleneck that affects efficient image rendering and increases the power required to obtain the final image on an electronic device.

FIG. 1 is an illustration of a graphics processing system 100 in which embodiments can be implemented. Graphics processing system 100 includes an application module 110, an application programming interface (API) 120, a driver module 130, a processing module 140 and a display module 150. Application module 110 can be an end-user application that requires graphics processing such as, for example and without limitation, a video game application. API 120 is configured to serve as an intermediary between application module 110 and driver module 130, according to an embodiment. In particular, API 120 can allow a wide range of common graphics functions to be written by software developers such that the graphics functions operate on many different hardware systems (e.g., processing module 140). Examples of API 120 include, but are not limited to, DirectX (from Microsoft) and OpenGL (from Silicon Graphics). Display module 150 can be, for example and without

limitation, a cathode ray tube display, a liquid crystal display, a light emitting diode display, or other similar types of display devices.

Driver module 130 is a computer program that allows a higher-level graphics computing program, from application module 110, to interact with processing module 140, according to embodiments. For instance, driver module 130 can be written by a manufacturer of processing module 140 to translate standard code received from API 120 into a native format understood by processing unit of processing module 140. Driver module 130 allows input from, for example and without limitation, application module 110 or a user to direct settings of processing module 140. Such settings include selection of an anti-aliasing control, a texture filter control, a batch binning control, and deferred pixel shading control. For example, a user can select one or more of these settings via a user interface (UI), including a UI supplied to the user with graphics processing hardware and software.

Driver module 130 issues commands to processing module 140. In an embodiment, driver module 130 receives a graphics operation from application module 110 via API 120. The graphics operations can include, for example and without limitation, texture mapping of a graphics scene. As would be understood by a person skilled in the relevant art, during a texture mapping operation, a texture is used to add detail, surface texture, or color to the graphics scene.

In an embodiment, processing module 140 is configured to receive a sequence of primitives and opportunistically segment primitives into temporally related primitive batches. Sequential primitives are captured until a predetermined condition is met, such as batch full condition, state storage full condition, or a dependency on previously rendered primitives is determined, according to an embodiment. In one example, primitive batches are formed based on a predetermined maximum batch value. In another example, a collapsible batch binning technique may be used, where the maximum amount of initially collected primitives for a primitive batch is fixed, but during the processing of primitives of bins, completed primitives can be dismissed making it possible to dynamically insert new primitives during processing to form a flexible primitive batch.

A screen space which displays a rendered primitive may be divided into a number of blocks, such as, a checker board pattern. Each block of screen space may be associated with a bin. According to an embodiment a size of a bin is dynamic and can be configured to be any size based on processing conditions. Each primitive of the received sequence of primitives of a batch may intersect one or more bins. For each received primitive in a batch the initial bin intercept is computed, where an initial bin intercept is the upper-most left bin of the screen which the primitive intersects. After a batch is closed, a first bin for processing is identified. Primitives intercepting the identified bin are processed. For each primitive identified intercepting the bin, the next bin intercept is identified and the pixels included in the primitive that are enclosed by the identified bin are sent for detailed rasterization. The next bin intercept is the next upper-most left bin in raster order which the processed primitive intersects.

According to an embodiment, if a deferred shading operation is enabled, pixel shading is delayed. In an embodiment, processing module 140 accumulates fragments associated with primitives based on x,y screen coordinates. Primitives are rasterized into “pixel fragments”. Processing module 140 is configured to perform tests on the fragments and perform filtering operations to determine which fragments will need to be shaded. In any given scene to be rendered,

primitives may overlap or primitives may be transparent, for example. Thus, certain primitives and their corresponding fragments may not contribute to the final color or depth of a scene. Processing module 140 is configured to discard fragments which do not contribute to a final pixel color or pixel depth prior to performing any shading operation. The use of deferred primitive batch binning in an immediate mode rendering system is opportunistically employed and degrades to an immediate mode rendering system with small delay when a primitive batch size is based on one or more conditions forcing receipt of only one primitive per batch. Additionally the deferred primitive batch binning does is a completely embedded hardware process which results in reduced external bandwidth. The deferred batch binning processing mechanism will be discussed in greater detail below.

FIG. 2 is an illustration of an embodiment of processing module 140. Processing module 140 includes a processing unit 210, a memory management unit (MMU) 220, and a memory device 230. Processing unit 210 can be, for example and without limitation, a central processing unit (CPU), a graphics processing unit (GPU), an accelerated processing unit (APU), an application-specific integrated circuit (ASIC) controller, or other similar types or combinations thereof of processing units. Processing unit 210 is configured to execute instructions and to carry out operations associated with graphics processing system 100 of FIG. 1. For instance, graphics processing system 100 can be configured to render and display graphics. MMU 220 is configured to handle accesses to memory device 230 requested by processing unit 210. The functions of MMU 220 include, for example and without limitation, translation of virtual addresses to physical addresses (e.g., virtual memory management), cache control, and bus arbitration. Memory device 230 can be, for example and without limitation, a random access memory device (e.g., Dynamic Random Access Memory, Static Random Access Memory, etc.), a Flash memory device, or other similar types of memory devices.

FIG. 3 illustrates an immediate mode rendering system 300, according to embodiments. Immediate mode rendering system 300 includes a processor 302, a CPU 304 and a GPU 306. To solve the drawbacks of graphics pipelines discussed above, the GPU 306 in the example shown in block diagram 300 includes batch binning module 312 and accumulator 316.

CPU 304 and GPU 306 are communicatively coupled to memory interface 322. In an embodiment, GPU 306 is a processor that is a specialized electronic circuit designed to rapidly process mathematically intensive applications on electronic devices. The GPU may have a highly parallel structure that is efficient for parallel processing of large blocks of data, such as mathematically intensive data common to computer graphics applications, images and videos.

Memory interface 322 provides an interface between CPU 304 and GPU 306 and the Memory Management Unit 220 of FIG. 2 for access to a main memory or private memory, such as random access memory (RAM) (not shown). Memory interface 322 can store, e.g., processing logic instructions, constant values, and variable values during execution of portions of applications or other processing logic. For example, in one embodiment, parts of control logic to perform one or more operations on CPU 304 can reside within memory interface 322 during execution of the respective portions of the operation by CPU 304. The term “processing logic” or “logic,” as used herein, refers to

control flow commands, commands for performing computations, and commands for associated access to resources.

In an example, memory interface 322 can include command buffers or access to them from main memory (not illustrated) that are used by CPU 304 to send commands to GPU 306 or directly by the GPU 306. Memory interface 322 can also include process lists and process information. The process lists and process information are used by scheduling software executing on CPU 304 to communicate scheduling information to GPU 306 and/or related scheduling hardware.

GPU 306 includes commander processor 308, primitive pipeline 310, primitive batch module 312, scan converter 314, accumulator 316, depth and color processing module 318 and unified shader system 320. Command processor 308 controls the processing within GPU 306. Command processor 308 also retrieves instructions to be executed from command buffers in memory interface 322 and coordinates the execution of those instructions on GPU 306. In one example, CPU 304 inputs commands based on applications 111 (of FIG. 1) into appropriate command buffers of memory interface 322 or sends commands directly to command processor 308. Command processor 308 can be implemented in hardware, firmware, or software, or a combination thereof. In one embodiment, command processor 308 is implemented as a RISC engine with microcode for implementing logic including scheduling logic.

Primitive pipeline 310 generates a sequence of primitives which will be ultimately rendered for display by GPU 306. Primitives include points, lines, polygons or a combination of primitives that are organized into a mesh. A commonly generated primitive is a triangle. The primitive pipeline 310 uses program data and 3D object data to transform geometry from a world coordinate space to screen space. After all surface, geometry, tessellation, clipping, culling, viewport transform and primitive setup processing is completed, a series of primitives in screen space is emitted for rasterization.

Primitive batch module 312 is configured to receive a sequence of primitives from primitive pipeline 310. Upon receipt of a sequence of primitives, primitive batch module 312 is configured to generate a primitive batch, according to an embodiment. A primitive batch is generated by segmenting or capturing a subset of the sequence of primitives. The primitives included in a primitive batch are temporally related, according to an embodiment. Temporally related primitives are segmented into a batch until a predetermined threshold is met. For example, sequential primitives may be captured into a primitive batch until a predetermined condition is met, such as batch full threshold, state storage full threshold, a primitive dependency threshold, or if the incoming primitive is identified as a last primitive. In one example, a primitive batch is formed based on a predetermined maximum batch value. In another example, collapsible batch binning technique may be used, where the maximum amount of collected primitives is fixed, but it is possible to dynamically insert and remove primitives from a batch as needed. According to an embodiment, when a primitive batch is at a maximum capacity, double-buffering of additional sequence of primitives is performed. The double buffering occurs while the primitive batch is processed. In this way primitives may continue to be received and stored while processing is occurring.

According to an embodiment, while a primitive batch is captured, primitive batch module 312 is configured to identify initial bin intercepts for primitives included in the primitive batch. A screen space which displays rendered primitives may be divided into a number of rectangular

blocks, such as, a checker board pattern. Each rectangular block of screen space may be associated with a bin. The received sequence of primitives may intersect one or more bins based on the location and size of the primitive. According to an embodiment, an initial bin intercept for a primitive is the upper-most left bin which a primitive intersects. Initial bin intercepts are computed and said information is stored on a per-bin basis. A per bin primitive storage, such as a linked list or scoreboard, is utilized to store information related to the primitive batch. For example, the per bin primitive storage can store information identifying a list of intersecting primitives for each bin. In another example, a special bin processing walk order can be determined and only require the initial bin intercepts to be stored.

According to an embodiment, primitive batch module **312** is configured to identify a bin for processing. A bin can be identified based on the corresponding screen location of primitives included in a primitive batch, according to an embodiment. For example, a bin including primitives associated with the furthest upper left rectangular block region of a screen space can be processed first. Primitive batch module **312** is configured to use the per bin storage to identify a bin to be processed, according to an embodiment. For example, by analyzing the coordinates of all the initial bin intercepts, primitive batch module **312** can determine which bin is the upper-most left bin that includes an intersecting primitive.

Primitive batch module **312** is further configured to process all primitives of the batch intersecting the identified bin. For example, for each primitive intersecting the identified bin, the portion of the primitive which is located within the bin is processed by primitive batch module **312**. The processed portion of the primitive is then passed to scan converter **314** for rasterization. Primitive batch module **312** is then further configured to identify next bin intercepts for the processed primitive. A next bin intercept is the next upper-most left bin which the processed primitive intersects, according to an embodiment. Information related to the next bin intercept may be stored in the per bin storage area.

As primitives are received by primitive batch module **312**, an arrival identifier is assigned to each primitive. The arrival order determines the order in which primitives of an identified bin are processed. Thus, if primitive batch module **312** identifies multiple intersecting primitives for a particular bin, the primitives included within said bin are processed in an order based on arrival using the assigned arrival identifier. Primitive batch module **312** is configured to iteratively process all the primitives for each of the successive bins including primitives until all primitives of the primitive batch have been completely processed, according to an embodiment.

In one example, scan converter **314** receives primitive and bin location data from primitive batch module **312** for use to determine which pixels are interior to the edges of the passed primitives and bin. Prior to passing the resulting pixels to the accumulator **316**, depth and color processing module **318** may perform multiple depth test operations for each pixel or fragment to opportunistically remove hidden fragments that can be determined behind previously rendered objects. The surviving pixels or fragments information is then passed to accumulator **316**. In an embodiment, a deferred shading processing operation can be enabled. If deferred shading operation is enabled, pixel shading is delayed until receipt of a complete set of pixels for the identified bin. Based on the received data from scan converter **314**, accumulator **316** uses the source pixels x, y, and z coordinate position of each fragment within the bin to determine what needs to be shaded. Additionally, the source position and z coordinates

are used by accumulator **316** to determine if earlier received fragments for a given X, Y screen location are further from the eye than the arriving fragment.

Accumulator **312** is then configured to determine contributing and non-contributing fragments within the bin. The depth tests performed by depth and color processing module **318** may remove certain portions of primitives may not factor into the final color or depth tests. Accumulator **312** is configured to further identify fragments which do not contribute to the final color or depth and discard those fragments. In this way, accumulator **316** performs filtering operations to determine which fragments will be shaded. For example, if a fragment is determined to be opaque (i.e. not translucent) and closer to the eye than previously received fragments for a given screen X,Y, then the previous fragment is discarded because the previous fragment will not contribute to the final color. In another embodiment, if the later arriving pixel or fragment in a sequence of primitives passes an early opportunistic hierarchical Z depth test but is determined using the source Z to be further from the eye than an earlier processed opaque pixel for the same screen XY of the same bin, then the arriving fragment can be discarded prior to pixel shading by accumulator **316**. Thus, embodiments create a deferred batch binning processing mechanism which reduces the number of pixel shading operations that are needed.

When accumulator **316** completes its filtering operations for a bin, accumulator **316** organizes the remaining pixels (i.e. contributing fragments) for all pixels of the bin into groups the width of the vector units included in the unified shader system and then transmits the groups to unified shader system **320** for shading operations to be completed.

In one example, unified shader system **320** associates each group of fragments with a particular shader program. Unified shader system **320** can include an array of processing elements capable of performing several different types of shader programs. Unified shader system **320** may execute, for example, a vertex shader, a geometry shader, and a pixel shader where a pixel shader can execute a user supplied program on a group of pixels assembled and input by the accumulator **316**. In addition to the typical graphics-processing tasks (e.g., vertex shaders, geometry shaders, pixel shaders, etc.), unified shader system **302** can perform general-compute operations (e.g., mathematical algorithms, physics simulations, etc.).

One skilled in the relevant arts will appreciate that while embodiments are discussed in reference to a single immediate mode rendering system, embodiments are scalable to include a plurality of immediate mode rendering systems.

FIGS. 4A-4I illustrate an example of deferred batch binning in an immediate mode rendering system, according to embodiment. FIG. 4A illustrates a screen space area **402**, which has been divided into a plurality of rectangular regions or bins **404A-404P**. One skilled in the relevant art will appreciate that the divisions illustrated in FIG. 4A is by way of non-limiting examples, and other divisions are contemplated and can be utilized within the scope of the disclosed embodiments.

FIG. 4B illustrates the receipt of a first primitive **406**. An initial bin intercept is calculated for first primitive **406**. In this example, the initial bin intercept of first primitive **406** is bin **404A**. In other words, bin **404A** is the upper-most left bin which first primitive **406** intersects. One skilled in the relevant arts will appreciate that other techniques to determine an initial bin intercept can be utilized consistent with this disclosure. However, for the purposes described herein, an upper-most left bin intercept is computed by determining

first the upper-most bin row intercepted by the primitive, and then the left-most bin intercepted by the primitive within that row. This arrangement is readily adaptable to other orientations and processing orders.

FIG. 4C illustrates the receipt of a second primitive **408**. Similar to first primitive **406** of FIG. 4B, an initial bin intercept of second primitive **408** is computed. In this example, the first bin intercept of second primitive **408** is bin **404D** (rather than **404G**), since bin **404D** is found in the upper-most bin row intercepted by the primitive, and is the left-most bin (in fact, the only bin) intercepted by the primitive within that row.

FIG. 4D illustrates the receipt of a third primitive **410**. Similar to first primitive **406** of FIG. 4B and second primitive **408** of FIG. 4C, an initial bin intercept of third primitive **410** is computed. In this example, the first bin intercept of third primitive **410** is bin **404F**.

FIG. 4E illustrates the generation of a primitive batch including first primitive **406**, second primitive **408** and third primitive **410**. As discussed previously, a primitive batch may include primitives based on a predetermined threshold, such as a number of primitives that can be handled based on memory constraints. Additionally, a batch may be generated using a set of received primitives based on a determination that a subsequently received primitive (not illustrated) is dependent upon the processing of at least one of first primitive **406**, second primitive **408** and third primitive **410**. Such a dependency may affect the final shading of the subsequently received primitive. In such a scenario, the primitive batch would not include the subsequently received primitive. Rather, a new primitive batch is generated for the subsequently received primitive, which can be processed once the current batch is processed and the dependency is resolved. The new primitive batch is processed at a later time. Returning to FIG. 4E, once the primitive batch is complete, the processing of primitives commences. In this example, processing of primitives will occur on a per-bin basis, starting at bin **404A**. At bin **404A**, the portion of first primitive **406** intersecting bin **404A** is processed and sent for rasterization. While the portion of first primitive **406** is processed, a next bin intercept of first primitive **406** is computed. In this example, the next bin intercept of first primitive **406** is bin **404B**. As with computing the initial bin intercept, the next bin intercept is the next upper-most left bin which a primitive intersects.

FIG. 4F illustrates further processing of primitives in the primitive batch. As illustrated, the processing moves in an ordered-manner (i.e. walk order) to the next bin that has a primitive intersect. In this example, the walk order of bins is executed in a left to right manner for each row of bins. However, embodiments are not limited to this ordering scheme. According to an embodiment a walk order and next bin for processing can be dynamic. An orientation of the walk order can include multiple starting direction and starting locations as long as the identified walk order is maintained.

In FIG. 4F, bin **404B** is identified for processing and the portion of first primitive **406** which intersects bin **404B** is processed and sent for rasterization. The next bin intercept of first primitive **406** is also determined as bin **404E**, which is the next upper-most left bin intersected by primitive **406**.

FIG. 4G illustrates that the next bin with a primitive intersect is processed. Bin **404C** is skipped since it has no intersecting primitives, and the primitive intersecting bin **404D** is processed. In this example, the portion of second primitive **408** intersecting bin **404D** is processed and sent for

rasterization. At the same time, the next bin intercept of second primitive **408** is computed as bin **404G**.

FIG. 4H illustrates similar processing as the previous figures, as the portion of first primitive **406** which intersects bin **404E** is processed while the next bin intercept of the first primitive **406** is computed as bin **404F**.

FIG. 4I illustrates the processing of the primitives intersecting bin **404F**. As illustrated, multiple primitives intersect bin **404F** (i.e. first primitive **406** and third primitive **410**). As discussed previously, each primitive is assigned an arrival identifier in order to maintain the processing sequence of primitives. Thus, in this example, first primitive **406** is processed first followed by third primitive **410**. The portion of first primitive **406** intersecting bin **404F** is processed and sent for rasterization and a next bin intercept of first primitive **406** is computed as bin **404I**. Thereafter, the portion of third primitive **410** intersecting bin **404F** is processed and sent for rasterization, while the next bin intercept of third primitive **410** is computed as bin **404G**.

It is important to note that FIG. 4I illustrates primitives including portions which overlap. In conventional immediate mode rendering systems, the pixels located in bin **404F** and associated with first primitive **406** are shaded even though said pixels are completely covered/occluded by the portions of third primitive **410** in bin **404F**. That is because in conventional immediate mode rendering systems, the pixels of third primitive **410** are not known at the time of the rendering of first primitive **406**. With embodiments, shading of pixels in a bin can be deferred until all pixels of each primitive of the primitive batch have been rasterized for the identified bin (with HiZ and/or earlyZ testing). With embodiments, pixels are accumulated at a given pixel screen location and through testing and comparison, it can be determined which pixels contribute to a final color or depth. Only contributing pixels are then shaded. Thus unnecessary shading operations are not performed.

FIG. 5 is a flowchart illustrating a process for deferred primitive batch binning, according to an example embodiment.

At step **502**, a primitive batch may be generated from a sequence of primitives. For example a primitive batch may be generated by primitive batch module **312** of GPU **306**. A generated primitive batch includes a subset of the sequence of primitives. The primitives included in a primitive batch are temporally related. Temporally related primitives are segmented into a batch until a predetermined threshold is met. For example, sequential primitives may be captured into a primitive batch until a predetermined condition is met, such as a batch full threshold, a state storage full threshold, if an incoming primitive is identified as a last primitive, or a primitive dependency threshold.

At step **504**, initial bin intercepts are identified for primitives included in the primitive batch. For example, initial bin intercepts may be identified by batch binning module **312** of GPU **306**. A bin corresponds to a rectangular boundary region of a screen space. A screen space may be divided into multiple rectangular blocks. Thus, for a given screen space, there can be a plurality of bins. The number of bins may correspond to the number of rectangular boundary regions, according to an embodiment. The primitives included in a primitive batch may intersect one or more bins. An initial bin intercept for a primitive is the upper-most left bin which a primitive intersects. Initial bin intercepts are computed for all primitives in the primitive batch and said information is stored on a per-bin basis.

At step **506**, a bin for processing is identified. For example, a bin for processing may be identified by batch

11

binning module **312** of GPU **306**. A bin processing order can be pre-determined. For example, the bin processing order can be based on the left-to-right traversal of bins within a screen space region. Thus, in such a scenario, the upper most left bin is processed first followed by the next bin which is adjacent and to the right. The initial bin intercept information that was identified at step **504** may be used in determining a bin to be processed. Based on the initial bin intercepts, the upper-most left bin which includes a primitive is identified as the bin to be processed.

At step **508**, primitives intercepting the identified bin are processed. For example, primitives intersecting the identified bin are processed by batch binning module **312** of GPU **306**. For each primitive intersecting the identified bin, the portion of the primitive which is located within the bin is processed. The processed portion of the primitive is then transferred for rasterization. When multiple primitives intersect a particular bin, the multiples primitives may be processed during one bin-pass, since all primitives of an identified bin are processed prior to moving on to subsequent bins.

At step **510**, a next bin intercept is identified for the processed primitive. For example, step **510** may be performed by batch binning module **312** of GPU **306**. A next bin intercept is the next upper-most left bin which the processed primitive intersects, according to an embodiment. Information related to the next bin intercept may also be stored

FIG. **6** is a flowchart illustrating a process for deferred shading, according to an example embodiment.

At step **602**, shading of pixels associated with each primitive is delayed until receipt of a complete set of pixels for the identified bin. For example, shading of pixels may be delayed by accumulator **216** of processing unit **210**. Shading of pixels is delayed when a deferred shading operation is enabled, according to embodiment. A deferred shading operation is a command to halt shading of pixels associated with a primitive.

At step **604**, contributing and non-contributing fragments associated with the identified bin are determined. For example, step **604** may be performed by accumulator **216** of processing unit **210**. Primitives are rasterized into "pixel fragments". Fragments are subsequently shaded to compute a color to be used for final blending at each pixel of a display. Fragments within the identified bin may overlap. Such overlapping may result in certain fragments not contributing to the final color or depth because these fragments are either completely occluded or the fragments. Such fragments are determined to be non-contributing fragments. Transparent fragments require special handling and may result in the need to shade more than one pixel per screen X, Y for a given bin. One skilled in the relevant art will appreciate the need to shade multiple transparent pixels and one opaque backing primitive. While fragments that factor into the final pixel color or depth are determined to be contributing fragments.

At step **606**, non-contributing fragments are discarded. Non-contributing fragments may be discarded by accumulator **216** of processing unit **210**. Non-contributing fragments are discarded prior to performing a shading operation. If a fragment is determined to be non-contributing, the fragment is discarded because performing shading operations on such pixels is not necessary and would be an inefficient use of bandwidth and ALU capabilities. In this way embodiments reduce the number of pixel shading operations that are needed.

At step **608**, the contributing fragments of the identified bin are shaded.

12

Embodiments can be accomplished, for example, through the use of general-programming languages (such as C or C++), hardware-description languages (HDL) including Verilog HDL, VHDL, Altera HDL (AHDL) and so on, a programmable shader running as a pre-process to a GPU, or other available programming and/or schematic-capture tools (such as circuit-capture tools). The program code can be disposed in any known computer-readable medium including semiconductor, magnetic disk, or optical disk (such as CD-ROM, DVD-ROM). As such, the code can be transmitted over communication networks including the Internet and internets. It is understood that the functions accomplished and/or structure provided by the systems and techniques described above can be represented in a core (such as a CPU core and/or a GPU core) that is embodied in program code and may be transformed to hardware as part of the production of integrated circuits.

In embodiments, a tangible apparatus or article of manufacture comprising a tangible computer useable or readable medium having control logic (software) stored thereon is also referred to herein as a computer program product or program storage device. This includes, but is not limited to, immediate mode rendering system **300**, and memory interface **322** discussed above, as well as tangible articles of manufacture embodying any combination of the foregoing. Such control logic, when executed by one or more data processing devices (such as immediate mode rendering system **300**), causes such data processing devices to operate as described herein.

In this document, the terms "computer program medium" and "computer-usable medium" are used to generally refer to media such as a removable storage unit or a hard disk drive. Computer program medium and computer-usable medium can also refer to memories, such as system memory and graphics memory which can be memory semiconductors (e.g., DRAMs, etc.). These computer program products are means for providing software to an APD.

FIG. **7** illustrates an example of batch binning and sorting in an immediate mode rendering system, according to an embodiment. FIG. **7** illustrates a screen space area **702**, which has been divided into a plurality of rectangular regions or bins **704A-704P**, (also designated B0-B15). One skilled in the relevant art appreciate that the divisions illustrated in FIG. **7** is by way of non-limiting examples, and other divisions are contemplated and can be utilized within the scope of the disclosed embodiments. The sector may be divided into rows, (R0, R1, R2, R3) and columns (C0, C1, C2, C3).

Primitives, (designated "T1", "T2" and "T3"), are shown in a sector of screen space area **702**. For purposes of example, primitive T1 is shown as intersecting bins B0, B1, B2, B5 and B6. It should be understood that any number of primitives may occupy the screen space area **702** and intersect more or less bins. As can also be seen in FIG. **7**, the primitive T1 intersects bins that are only in rows R0 and R1 and columns C0, C1 and C2. Accordingly, bins in rows R2 and R3 and/or in column C3 need not be considered for processing for primitive T1. Primitive T2 is shown intersecting bins that are only in rows R1 and R2 and columns C2 and C3. Primitive T3 is shown intersecting only bins that are in rows R0 and R1 and columns C2 and C3. Furthermore, although only three primitives are depicted for example purposes, it should be noted that any number of primitives can occupy the screen space area **702**.

In batch binning mode, the order in which the primitives would be processed are: T1-B0, T1-B1, T1-B2, T3-B2, T3-B3, T1-B5, T1-B6, T2-B6, T3-B6, T2-B7, T3-B7,

T2-B10 and T2-B11. Accordingly, whenever multiple primitives intercept a given bin, (such as in the case of bins B2, B6 and B7), all those primitives sections are processed in a row, increasing cache utilization and memory efficiency. In immediate mode rendering, the processing order would be T1 (all bins that it intercepts), T2 and then T3. This rasterization order induces memory inefficiencies as the process returns multiple times to bins B2, B6 and B7.

FIG. 8 is an example schematic representation of a system 800 for performing batch binning and sorting, according to an embodiment. The system 800 includes a VSpanRasterizer 810 operatively coupled to a VSpanSorter 820, which is also operatively coupled to an HSpanRasterizer 830. The HSpanRasterizer 830 is operatively coupled to an HSpanSorter 840. An example operation of the VSpanRasterizer 810, VSpanSorter 820, HSpanRasterizer 830, and HSpanSorter 840 is discussed in the context of the example method depicted in FIG. 9 following.

FIGS. 9A-9B depict a flow diagram of an example method 900A/900B for performing batch binning and sorting, according to an embodiment. Steps 910-950 are performed by the VSpanRasterizer 810 and VSpanSorter 820. Steps 960-990 are performed by the HSpanRasterizer 830 and the HSpanSorter 840. In step 910, the method begins by receiving a primitive, (e.g., from the primitive pipeline 310), and storing the primitive by the rows it intercepts, (i.e., VSpanRasterizer 810 calculating and storing the rows the primitive intercepts in the row sorter, (e.g., VSpanSorter 820)). For example, referring back to FIG. 7, primitive T1 intercepts bins B0, B1, B2, B5 and B6, which are located only in rows R0 and R1. Therefore R0 is the minimum ("min") row and R1 is the maximum ("max") row that primitive T1 intercepts. Since primitive T2 intercepts bins B6, B7, B10 and B11, (located only in rows R1 and R2), R1 is the min row and R2 is the max row that primitive T2 intercepts. Since primitive T3 intercepts bins B2, B3, B6 and B7 (located only in rows R0 and R1), R0 is the min row and R1 is the max row that primitive T3 intercepts. Those min and max rows are stored in VSpanSorter 820. The information is stored in a memory that is 16 primitives wide, (e.g., 16 min and max row IDs), and encoded for each row of primitives the size of the group of primitives. The encoding may be in the form of the min of the min and max of the max, (e.g., R0 (the min of T1) and R2 (the max of T2), and/or a mask, (e.g., hierarchical mask), of the rows the set of primitives touch. That is, a row mask can be stored that represents the rows intercepted by all primitives, (e.g., R0, R1, and R2 for T1, T2 and T3), or a group of primitives, (e.g., R0 and R1 for primitives T1 and T3).

If a batch break condition, (i.e., a condition that terminates the processing of a batch of primitives such as T1 T2, and T3), is not met (step 920), then the method reverts to step 910. For example, a batch break condition occurs when there is not enough space in memory to store primitives, an event is inserted into the process by a driver to flush, (i.e., commit to processing), the batch, or there are not enough state contexts. State contexts include all the register data that is associated with a draw, such as the number of pixel shader exports, the number of vertex shader parameters, whether anti-aliasing mode is enabled, the number of samples per pixel, or the number of render targets. However, if a batch break condition is met in step 920, then each row containing primitives is sent (step 930) for further processing in step 940. That is, the VSpanRasterizer 810 continues performing method 900A by considering in the next step, (i.e., step 940),

each row containing primitives if a batch break condition is met in step 920 by sending those rows in step 930 to the next step in the method 900A.

In step 940, all primitives from the row sent in step 930 are sent for further processing in step 960. That is, the VSpanRasterizer 810 and VSpanSorter 820 continue performing method 900A by sending all primitives from the row that was sent for further processing in step 930 to the HSpanRasterizer 830 and HSpanSorter 840 for further processing in step 960. The method proceeds in multiple directions at this point. For example, the method proceeds to step 950, where it is determined whether all rows, for example from screen space area 702, (i.e. R0, R1, R2, and R3), have been processed. That is, it is determined whether or not all rows containing primitives have been sent in step 930 for further processing in step 940. If they have not, the method reverts back to step 930 to send additional rows that contain primitives that have not yet been sent for further processing in step 940. If they have, the method reverts to step 910. In addition, once all primitives from the current row are sent in step 940 to step 960 for further processing, they are received, (e.g., by the HSpanRasterizer 830), and stored, (e.g., by the HSpanSorter 840), and the columns they intercept are calculated and stored (step 960). Each column that is calculated to contain a primitive is then sent (step 970) for further processing in step 980. That is, the HSpanRasterizer 830 continues performing method 900B by considering in the next step, (i.e., step 980), each column containing primitives by sending those columns in step 970 to the next step in the method 900B. For example, referring back to FIG. 7, since the primitive T1 intercepts column C0, that column is sent. In step 980, all primitives from the column that was sent in step 970 for further processing are sent by the HSpanRasterizer 830 and HSpanSorter 840 for rasterization in step 995. After this step, (i.e., step 980), it is determined whether or not all columns, for example from screen space area 702, (i.e. C0, C1, C2, and C3), have been processed (step 990). That is, it is determined whether or not all columns containing primitives have been sent in step 980 for further processing in step 995. If they have, the method reverts to step 960. If they have not, the method reverts to step 970 to send additional columns that contain primitives that have not yet been sent for further processing in step 980. In step 995, a scissor rectangle, (e.g., to set a boundary area for rendering), is set according to the current row and column, (e.g., bin X,Y), and rasterization is performed by a rasterizer having sub-pixel precision, (e.g., scan convertor 314).

Accordingly, in the example of FIG. 7, the method 900, (i.e., 900A and 900B), includes investigating row R0 for primitives, (e.g., using the VSpanRasterizer 810), and then columns C0, C1, C2 and C3, (e.g., using the HSpanRasterizer 830). After querying all columns in row R0, the method returns and queries row R1 and then all columns in row R1. However, it should be noted that since the information of the mins and maxes of the rows and columns is known, rows and columns where it is known that no primitives intersect are ignored for querying. Accordingly, all primitives of the batch intercepting R0 are processed and sent to the VSpanRasterizer 810 before more rows are processed. Using the example shown in FIG. 7 again, primitives T1 and T3 are sent to the VSpanRasterizer 810 before row R1 is processed.

Based on the teachings contained in this disclosure, it will be apparent to persons skilled in the relevant art(s) how to make and use the embodiments using data processing devices, computer systems and/or computer architectures other than those shown in the Figures. In particular, embodi-

ments may operate with software, hardware, and/or operating system implementations other than those described herein.

CONCLUSION

It is to be appreciated that the Detailed Description section, and not the Summary and Abstract sections (if any), is intended to be used to interpret the claims. The Summary and Abstract sections (if any) may set forth one or more but not all exemplary embodiments as contemplated by the inventor(s), and thus, are not intended to limit the disclosure or the appended claims in any way.

While the disclosure has been described herein with reference to exemplary embodiments for exemplary fields and applications, it should be understood that the disclosure is not limited thereto. Other embodiments and modifications thereto are possible, and are within the scope and spirit of the disclosure. For example, and without limiting the generality of this paragraph, embodiments are not limited to the software, hardware, firmware, and/or entities illustrated in the figures and/or described herein. Further, embodiments (whether or not explicitly described herein) have significant utility to fields and applications beyond the examples described herein.

Embodiments have been described herein with the aid of functional building blocks illustrating the implementation of specified functions and relationships thereof. The boundaries of these functional building blocks have been arbitrarily defined herein for the convenience of the description. Alternate boundaries can be defined as long as the specified functions and relationships (or equivalents thereof) are appropriately performed. Also, alternative embodiments may perform functional blocks, steps, operations, methods, etc. using orderings different than those described herein.

References herein to “one embodiment,” “an embodiment,” “an example embodiment,” or similar phrases, indicate that the embodiment described may include a particular feature, structure, or characteristic, but every embodiment may not necessarily include the particular feature, structure, or characteristic. Moreover, such phrases are not necessarily referring to the same embodiment. Further, when a particular feature, structure, or characteristic is described in connection with an embodiment, it would be within the knowledge of persons skilled in the relevant art(s) to incorporate such feature, structure, or characteristic into other embodiments whether or not explicitly mentioned or described herein.

The breadth and scope of the disclosure should not be limited by any of the above-described exemplary embodiments, but should be defined only in accordance with the following claims and their equivalents.

What is claimed is:

1. A method for rasterizing, the method comprising:
 - generating a primitive batch from a sequence of one or more primitives, wherein the primitive batch includes primitives sorted into one or more row groups based on which row of a plurality of rows each primitive intersects; and
 - processing each row group, the processing for each row group including:
 - identifying one or more primitive column intercepts for each of the one or more primitives in the row group, wherein each combination of primitive column intercept and a respective row of the row group identifies a bin, and

rasterizing the one or more primitives that intersect the bin based on a display boundary area corresponding to an area of the bin.

2. The method of claim 1, further comprising setting a display area for rasterization corresponding to the area of the bin for each bin that includes a primitive.
3. The method of claim 1, wherein the primitive batch is generated by accumulating primitives of the sequence into different row groups.
4. The method of claim 1, further comprising determining whether a batch break condition exists before inserting a new primitive in the batch.
5. The method of claim 1, further comprising storing a mask that indicates one or more columns for each of the plurality of rows that contains at least one primitive.
6. The method of claim 1, wherein each row group is processed in turn, wherein the processing each row group comprises rasterizing each row group in order, wherein rasterizing each row group comprises rasterizing each bin in column order for each row group.
7. A system for rasterizing, the system for rasterizing comprising:
 - a memory configured to store a primitive batch, wherein the primitive batch is generated from a sequence of one or more primitives, wherein the primitive batch includes primitives sorted into one or more row groups based on which row of a plurality of rows each primitive intersects; and
 - a processing unit configured to process each row group, the processing for each row group including:
 - identifying one or more primitive column intercepts for each of the one or more primitives in the row group, wherein each combination of primitive column intercept and a respective row of the row group identifies a bin, and
 - rasterizing the one or more primitives that intersect the bin based on a display boundary area corresponding to an area of the bin.
8. The system of claim 7, wherein the processing unit is further configured to set a display area for rasterization corresponding to the area of the bin for each bin that includes a primitive.
9. The system of claim 7, wherein the primitive batch is generated by accumulating primitives of the sequence into different row groups.
10. The system of claim 7, wherein the processing unit is further configured to determine whether a batch break condition exists before inserting a new primitive in the batch.
11. The system of claim 10, wherein the batch break condition includes any one of the following: there is not enough space in a memory to store primitives, an event to flush the batch is issued, or there are not enough state contexts.
12. The system of claim 7, wherein the processing unit is further configured to store a mask that indicates one or more columns for each of the plurality of rows that contains at least one primitive.
13. The system of claim 7, wherein the processing unit is further configured to process each row group in turn, wherein the processing each row group comprises rasterizing each row group in order, wherein rasterizing each row group comprises rasterizing each bin in column order for each row group.

17

14. A non-transitory computer readable storage medium storing instructions that, when executed by a processor, cause the processor to perform operations for rasterizing, the operations comprising:

generating a primitive batch from a sequence of one or more primitives, wherein the primitive batch includes primitives sorted into one or more row groups based on which row of a plurality of rows each primitive intersects; and

processing each row group, the processing for each row group including:

identifying one or more primitive column intercepts for each of the one or more primitives in the row group, wherein each combination of primitive column intercept and a respective row of the row group identifies a bin, and

rasterizing the one or more primitives that intersect the bin based on a display boundary area corresponding to an area of the bin.

15. The non-transitory computer readable storage medium of claim 14, the operations further comprising setting a display area for rasterization corresponding to the area of the bin for each bin that includes a primitive.

18

16. The non-transitory computer readable storage medium of claim 14, wherein the primitive batch is generated by accumulating primitives of the sequence into different row groups.

17. The non-transitory computer readable storage medium of claim 14, the operations further comprising determining whether a batch break condition exists before inserting a new primitive in the batch.

18. The non-transitory computer readable storage medium of claim 14, wherein the batch break condition includes any one of the following: there is not enough space in a memory to store primitives, an event to flush the batch is issued, or there are not enough state contexts.

19. The non-transitory computer readable storage medium of claim 14, the operations further comprising storing a mask that indicates the one or more columns for each of the plurality of rows that contains at least one primitive.

20. The non-transitory computer readable storage medium of claim 14, wherein each row group is processed in turn, wherein the processing each row group comprises rasterizing each row group in order, wherein rasterizing each row group comprises rasterizing each bin in column order for each row group.

* * * * *