

(19)



(11)

**EP 3 768 181 B1**

(12)

**EUROPEAN PATENT SPECIFICATION**

(45) Date of publication and mention of the grant of the patent:  
**27.09.2023 Bulletin 2023/39**

(21) Application number: **19717363.6**

(22) Date of filing: **15.03.2019**

(51) International Patent Classification (IPC):  
**A61B 17/80<sup>(2006.01)</sup> A61B 17/86<sup>(2006.01)</sup>**

(52) Cooperative Patent Classification (CPC):  
**A61B 17/8057; A61B 17/8014; A61B 17/8061; A61B 17/8605**

(86) International application number:  
**PCT/IB2019/052132**

(87) International publication number:  
**WO 2019/180565 (26.09.2019 Gazette 2019/39)**

**(54) BONE PLATE WITH FORM-FITTING VARIABLE-ANGLE LOCKING HOLE**

KNOCHENPLATTE MIT FORMSCHLÜSSIGEM VERRIEGELUNGSLOCH MIT VARIABLEM WINKEL  
PLAQUE OSSEUSE AYANT UN TROU DE VERROUILLAGE À ANGLE VARIABLE À ADAPTATION DE FORME

(84) Designated Contracting States:  
**AL AT BE BG CH CY CZ DE DK EE ES FI FR GB GR HR HU IE IS IT LI LT LU LV MC MK MT NL NO PL PT RO RS SE SI SK SM TR**

(30) Priority: **20.03.2018 US 201815926390**

(43) Date of publication of application:  
**27.01.2021 Bulletin 2021/04**

(73) Proprietor: **DePuy Synthes Products, Inc. Raynham, Massachusetts 02767-0350 (US)**

(72) Inventors:  
• **BOSSHARD, Simon M. 4500 Zuchwil, Solothurn (CH)**

- **RUSH, Jesse Telford, Pennsylvania 18969 (US)**
- **MCGURK, Michael Chester, Pennsylvania 19380 (US)**
- **KEEGAN, Christopher Chester, Pennsylvania 19380 (US)**

(74) Representative: **Klunker IP Patentanwälte PartG mbB Destouchesstraße 68 80796 München (DE)**

(56) References cited:  
**DE-A1-102016 112 845 US-A1- 2018 064 476**  
**US-A1- 2018 064 477 US-A1- 2018 064 479**

**EP 3 768 181 B1**

Note: Within nine months of the publication of the mention of the grant of the European patent in the European Patent Bulletin, any person may give notice to the European Patent Office of opposition to that patent, in accordance with the Implementing Regulations. Notice of opposition shall not be deemed to have been filed until the opposition fee has been paid. (Art. 99(1) European Patent Convention).

## Description

### BACKGROUND

[0001] When bones are damaged through trauma, disease, distraction osteogenesis, or orthognathic surgery, the defect is typically reduced, and bone fixation plates are commonly applied to the bone on sides of the defect to ensure union in the desired position. Bone screws can be sized to be driven through respective fixation holes of the plate and into the underlying bone to secure the bone plate to the bone. One common bone screw used in such application is generally referred to as a compression screw. Compression screws have unthreaded heads and threaded shafts. Accordingly, the compression screw can be driven through the plate fixation hole and into the underlying bone until the head applies a compression force against the bone plate toward the underlying bone. Another common bone screw used in such applications is generally referred to as a locking screw. Locking screws have threaded heads and threaded shafts. The threaded heads purchase with the plate inside the fixation holes to reach a stable construct, able to transfer bending moments over the screw head / plate hole interface and to avoid loosening or backing out of the screws. In particular, the locking screw can be driven through the plate fixation hole and into the underlying bone until the head threadedly mates with the bone plate in the fixation hole. The threaded heads of locking screws typically do not apply a compressive force against the bone plate toward the underlying bone.

[0002] Conventionally, locking screws were inserted through the screw hole along the central screw hole axis in order to ensure that the threaded screw head mates with the plate in the threaded fixation hole. Locking screws can include standard-type locking screws and variable-angle screws. Standard-type locking screws are configured to lock within a bone fixation hole substantially only at a "nominal" orientation whereby the central screw axis is substantially coincident with the central hole axis. Locking screws can further include variable-angle locking screws, which are configured to selectively lock within a variable angle hole at an angle within a range of angles with respect to the central axis of the variable angle hole.

[0003] A bone plate with the features as defined in the preamble of claim 1 is known from US 2018/064476 A1. Further bone plates are known from US 2018/064477 A1, US 2018/064479 A1 and DE 10 2016 112845 A1.

### SUMMARY

[0004] According to the present invention, a bone plate includes an inner surface that is configured to face the underlying bone, and an outer surface opposite the inner surface. The bone plate can further include an internal surface that extends from the outer surface to the inner surface so as to define a hole that is oriented along a central hole axis, wherein the internal surface includes

1) a plurality of threaded regions that define respective columns of thread segments, and 2) a plurality of recessed surfaces that are disposed between respective adjacent ones of the thread segments, the recessed surfaces being offset radially outward with respect to the columns of thread segments. The bone plate can be configured to mate with a threaded head of a variable angle locking screw in the hole at an angle within a range of angles, such that the threaded head threadedly purchases with all of the columns of thread segments, and wherein the angle is oblique to the central hole axis, wherein the internal surface defines a plurality of transition regions between the columns and respective adjacent ones of the recessed surfaces, and wherein respective depths of the thread segments taper along the transition regions in a circumferential direction away from the respective columns to the respective recessed surface.

[0005] Preferred embodiments are set forth in the dependent claims.

### BRIEF DESCRIPTION OF THE DRAWINGS

[0006] The foregoing summary, as well as the following detailed description of illustrative embodiments of the present application, will be better understood when read in conjunction with the appended drawings. For the purposes of illustrating the locking structures of the present application, there is shown in the drawings illustrative embodiments. In the drawings:

Fig. 1A is a schematic perspective view of a bone plate in accordance with one embodiment of the present invention;

Fig. 1B is a cross sectional elevation view of the bone plate illustrated in Fig. 1A, taken along line 1B-1B;

Fig. 1C is a perspective view of a bone plate constructed in accordance with one embodiment;

Fig. 2A is a top perspective view of a portion of the bone plate illustrated in Fig. 1A, showing a variable angle locking hole defined by an internal surface of the bone plate that includes a plurality of columns of thread segments;

Fig. 2B is a bottom perspective view of the portion of the bone plate illustrated in Fig. 1A;

Fig. 2C is a top plan view of the portion of the bone plate illustrated in Fig. 2A;

Fig. 2D is a bottom plan view of the portion of the bone plate illustrated in Fig. 2B;

Fig. 3 is a cross-sectional view of the variable angle locking hole illustrated in Fig. 2C, taken along line 3-3;

Fig. 4 is an enlarged sectional perspective view of a portion of the variable angle locking hole illustrated in Fig. 2A, showing a column of thread segments, adjacent recesses, and transition regions that extend from the column to the adjacent recesses, respectively;

Fig. 5A is a perspective view of a variable angle lock-

ing bone screw mated in the variable angle locking hole illustrated in Fig. 2A at an oblique orientation; Fig. 5B is a side elevation view of the variable angle locking bone screw illustrated in Fig. 5A; Fig. 6A is a cross-sectional view of the variable angle locking hole illustrated in Fig. 5A taken along line 6A-6A, showing the head of the variable angle locking bone screw threadedly purchased with a first one of the columns of thread segments; Fig. 6B is a cross-sectional view of the variable angle locking hole illustrated in Fig. 5A taken along line 6B-6B, showing the head of the variable angle locking bone screw threadedly purchased with a second one of the columns of thread segments; Fig. 6C is a cross-sectional view of the variable angle locking hole illustrated in Fig. 5A taken along line 6C-6C, showing the head of the variable angle locking bone screw threadedly purchased with a third one of the columns of thread segments; Fig. 7A is a perspective view of a standard-type locking screw mated in the variable angle locking hole illustrated in Fig. 2A at a fixed nominal orientation; Fig. 7B is a side elevation view of the standard-type locking screw illustrated in Fig. 7A; Fig. 8A is a perspective view of a bone plate having a combination hole that includes a variable angle locking hole as illustrated in Fig. 2A and a compression hole that is open to the variable angle locking hole portion; Fig. 8B is a top plan view of the bone plate illustrated in Fig. 8A; and Fig. 8C is a cross-sectional view of the bone plate illustrated in Fig. 8A, showing a variable angle compression bone screw inserted into the compression hole of the combination hole and threadedly purchased in an underlying bone.

## DETAILED DESCRIPTION

**[0007]** The present disclosure can be understood more readily by reference to the following detailed description taken in connection with the accompanying figures and examples, which form a part of this disclosure.

**[0008]** Variable angle (VA) locking screws can have a tendency to cause cross-threading within an aperture of a bone plate in which they are inserted. Cross-threading can occur when the external threads on the screw head not fit appropriately and thus cross-thread the internal threading of the aperture. Cross-threading is problematic because it reduces the interference fit (also referred to as the "form-fit") between the internal threading of the aperture and the screw head threads, which can result in a reduction of stability of the locked screw head in the aperture of the bone plate. The present disclosure provides a bone plate having VA locking holes that are designed to lock with the heads of both standard-type and VA locking screws in a manner inhibiting or at least reducing cross-threading with respect to conventional var-

iable-angle bone plates.

**[0009]** Referring initially to Figs. 1A-1C, a bone fixation system 20 is configured to be implanted onto bone 22 so as to stabilize a first bone segment 24 with respect to a second bone segment 26 that is separated from the first bone segment 24 by a defect 28. In one example, the first bone segment 24 can be defined by the diaphysis of the bone, while the second bone segment 26 can be defined by the epiphysis of the bone. It should be appreciated, however, that the first and second bone segments 24 and 26 can be defined by any region of the bone 22 as desired. Further, the bone 22 can be any bone in the human or animal anatomy suitable for bone plate fixation. Further still, while the bone 22 is illustrated having first and second bone segments 24 and 26, it is appreciated that the bone 22 can include any number of defects or bone fragments as desired that are configured for fixation using the bone fixation system 20. For instance, the diaphysis of the bone can include a plurality of bone fragments.

**[0010]** The bone fixation system 20 can include a bone plate 30 and a plurality of bone anchors 32 that are configured to fix the bone plate 30 to the underlying bone 22, and in particular to each of the first and second bone segments 24 and 26. The bone anchors 32 include a head 33 and a shaft 35 that extends out with respect to the head 33 along a central anchor axis 53. The shaft 35 can extend directly from the head 33, or can extend from a neck that is disposed between the head 33 and the shaft 35. The shaft 35 can be threaded, such that the bone anchor 32 is configured as a bone screw 37 whose shaft 35 extends out relative to the head 33 along the central anchor axis 53, which can also be referred to as a central screw axis 53. The threaded shaft 35 can be configured to threadedly purchase in the underlying bone 22. For instance, one or more up to all of the bone screw 37 can be configured as a cortical screw whose threaded shaft 35 is designed and configured to threadedly mate to cortical bone. Alternatively or additionally, one or more of the bone screws 37 can be configured as a cancellous screw whose threaded shaft 35 is designed and configured to threadedly mate to cancellous bone. It is appreciated that cancellous bone screws have threads that have a greater pitch than threads of cortical bone screws. Further, the threads of cancellous bone screws typically extend out from the shaft of the bone screw a greater distance than the threads of cortical bone screws.

**[0011]** The bone plate 30 defines a bone plate body 31. The bone plate body 31, and thus the bone plate 30, defines a bone-facing inner surface 34 configured to face the underlying bone 22, and an outer surface 36 that is opposite the inner surface 34 along a transverse direction T. The bone plate 30 further defines a plurality of fixation holes 38 that extend through the bone plate body 31 from the inner surface 34 to the outer surface 36. In particular, each of the fixation holes 38 extends through the bone plate body 31, and thus through the bone plate 30, along a respective central hole axis 45. The central hole axis

45 can be oriented along the transverse direction T. Thus, the central hole axis 45 can be oriented normal to each of the inner surface 34 and the outer surface 36. It should be appreciated, of course, that the central hole axis 45 can be oriented in any suitable direction as desired, including a direction oblique to the transverse direction T.

**[0012]** The fixation holes 38 are sized to receive the shaft 35 of a respective one of the bone screws 37. Thus, the bone screws 37 that extend through fixation holes 38 are permanent bone screws, meaning that they remain after completion of the surgical procedure. This is distinguished from temporary fixation holes that, for instance, can be configured to receive temporary fixation members, such as Kirschner wires that are removed prior to completion of the surgical procedure. In this regard, the fixation holes 38 can be referred to as permanent fixation holes. Accordingly, during operation, the shaft 35 of the bone screw 37 can be inserted through a respective one of the fixation holes 38 and into the underlying bone 22. The bone screw 37 can then be rotated so as to cause the threaded shaft 35 to be driven into the underlying bone 22 as the threaded shaft 35 threadedly purchases with the underlying bone. The threaded shaft 35 can be driven into the underlying bone 22 until the head 33 engages the bone plate 30.

**[0013]** Certain ones of the fixation holes 38 can be unthreaded compression holes 52, while certain others of the fixation holes 38 can be threaded locking holes 44 and some holes can be a combination thereof, where a threaded locking hole 44 and an unthreaded compression hole 52 intersect each other to define a combination hole 90 (see Figs. 8A-8C). The bone plate 30 defines an internal compression surface 57 that can extend between the outer surface 36 and the inner surface 34 so as to at least partially define the compression hole 52. The bone plate 30 can similarly define an internal surface 39 that extends from the outer surface 36 to the inner surface 34 so as to define the locking hole 44.

**[0014]** Thus, one or more of the bone screws 37 can be configured as a compression screw 49 whose head 33 defines a compression head 58 that is configured to bear against the bone plate 30 in the compression hole 52 so as to apply a compressive force against the bone plate 30 toward the underlying bone 22. In particular, during operation, the shaft 35 of the compression screw 49 can be inserted through the compression hole 52 and driven into the underlying bone 22 as described above. In particular, rotation of the bone screw 37 causes the compression head 58 to compress against the internal compression surface 57. As a result, the compression head 58 causes the bone plate 30 to apply a compressive force against the underlying bone. At least a portion of the internal compression surface 57 is typically spherical or tapered as it extends from the outer surface 36 toward the inner surface 34 so as to prevent the compression head 58 from passing completely through the compression hole 52. The compression head 58 typically has an unthreaded external surface. Similarly, at least a portion

up to an entirety of the internal compression surface 57 that abuts the unthreaded external surface of the compression head 58 is typically unthreaded. Thus, it is common to drive compression screws 49 into the unthreaded compression holes 52. However, as is described in more detail below with respect to Figs. 8A-8C, the compression screws 49 can also be driven into the combination hole 90.

**[0015]** Alternatively, one or more up to all of the bone screws 37 can be configured as locking screws 41 that are configured to threadedly purchase with the bone plate 30 inside the threaded locking holes 44. In particular, the locking screws 41 can include an externally threaded head 33. During operation, the shaft 35 of the locking screw 41 can be inserted through the fixation hole 38 and driven into the underlying bone 22 as described above. In particular, rotation of the screw 37 causes the threaded head 33 to threadedly mate with the threaded locking hole 44. As a result, the screw head 33 fastens the bone plate 30 to the underlying bone 22 without applying a compressive force onto the bone plate 30 against the underlying bone 22. The bone plate 30 can be spaced from the underlying bone 22 when locked to the head 33. Alternatively, the bone plate 30 can abut the underlying bone 22 when locked to the head 33. At least a portion of the internal surface 39 is typically tapered as it extends from the outer surface 36 toward the inner surface 34. Thus, the internal surface 39 is configured to prevent the head 33 from passing completely through the threaded locking hole 44.

**[0016]** One or more of the locking screws 41 can be configured as a standard-type locking screw 51. The standard-type locking screw 51 has an externally threaded locking head 56 that is configured to threadedly purchase to the bone plate 30 in the locking hole 44 when the standard-type locking screw 51 is at predetermined orientation with respect to the central hole axis 45. For instance, the predetermined orientation can be the nominal orientation whereby the central screw axis 53 is coincident with the central hole axis 45.

**[0017]** Alternatively or additionally, one more of the locking screws 41 can be configured as a variable angle (VA) locking bone screw 43 having a VA threaded head 59. Correspondingly, one or more of the threaded locking holes 44 can be configured as variable angle (VA) locking holes 54. The bone plate 30 is configured to threadedly mate with the VA threaded head 59 in the VA locking holes 54 when the central screw axis 53 of the VA bone screw 43 is oriented at any one of a plurality of angles within a range of angles with respect to the central hole axis 45 at which the VA threaded head 59 is configured to threadedly mate with the bone plate 30 in the VA locking hole 54. Further, as is described in more detail below with respect to Figs. 7A-7B, the bone plate 30 can be configured to threadedly mate with the standard-type locking screw 51 in the VA locking hole 54. Further still, as is described in more below with respect to Figs. 8A-8C, the bone plate 30 can be configured to receive the

compression screw 49 in the combination hole 90. The bone plate 30 can be referred to as a locking compression plate, as its fixation holes are configured to engage compression screws and locking screws, respectively.

**[0018]** While the bone plate 30 is illustrated schematically in Figs. 1A-1B, the bone plate 30 is illustrated in Fig. 1C as configured for fixation to the underlying bone 22. In one example, the bone plate body 31, and thus the bone plate 30, can include a first plate portion that can define a plate head portion 40 that is configured to overlie the second bone segment 26, and a second plate portion that can be referred to as a plate shaft portion 42 that is configured to overlie the first bone segment 24. Each of the plate head portion 40 and the plate shaft portion 42 can include at least one up to a plurality of bone fixation holes 38. Thus, bone anchors 32 that extend through respective fixation holes 38 of the plate head portion 40 can be driven into the epiphysis region of the underlying bone, and bone anchors 32 that extend through respective fixation holes 38 of the plate shaft portion 42 can be driven into the diaphysis region of the underlying bone. The epiphysis region can, for instance, be defined by the distal region of the radius bone. Any one or more up to all of the fixation holes 38 of the bone plate 30 can be compression holes, locking holes, VA locking holes or a combination thereof (also referred to as the "combination holes" described herein with reference to Figs. 8A-8C).

**[0019]** In one example, all of the fixation holes 38 in the plate head portion 40 can be configured as VA locking holes 54. Further, in one example, all of the fixation holes 38 in the second plate portion 42 are compression holes 52 configured to receive cortical bone screws. Further, at least one or more up to all of the compression holes can be configured as slots that are elongate along a central longitudinal axis of the bone plate 30 to allow for positional flexibility of the bone screw 37 received therein. Alternatively or additionally, at least one or more up to all of the compression holes can have a circular cross-section so as to locate the position of the bone screw 37 received therein. While the bone plate 30 has been described in accordance with one specific example, it should be appreciated that the bone plate 30 can be configured in any suitable manner as desired. Further, bone plates 30 constructed in accordance with any of the examples described herein can be configured to attach to any region or region or regions of any suitable bone in the human or animal anatomy suitable for bone plate fixation.

**[0020]** The bone plate 30 and the locking screws 41 can each comprise one or more biocompatible materials, such as titanium, titanium alloys (e.g., titanium-aluminum-niobium (TAN) alloys, such as Ti-6Al-7Nb), stainless steel, cobalt base alloys, composite materials, and polymeric materials and/or ceramic materials, by way of non-limiting examples. In one example, the material of the locking screws 41 can have a hardness that is greater than that of the bone plate 30. For instance, the bone

plate 30 can primarily or entirely be made of titanium, and the locking screws 41 can primarily or entirely comprise Ti-6Al-7Nb (TAN).

**[0021]** The VA locking hole 54 will now be described in more detail with respect to Figs. 2A-4. As described above, the internal surface 39 of the bone plate 30 extends from the outer surface 36 to the inner surface 34 so as to define the VA locking hole 54 that extends from the outer surface 36 to the inner surface 34. In particular, the VA locking hole 54 extends along the central hole axis 45. The central hole axis 45 can be oriented along the transverse direction T. Thus, the central hole axis 45 can be oriented normal to each of the inner surface 34 and the outer surface 36. It should be appreciated, of course, that the central hole axis 45 can be oriented in any suitable direction as desired, including a direction oblique to the transverse direction T.

**[0022]** The internal surface 39, and thus the bone plate 30, defines a plurality of threaded regions 62 that each carries at least one thread 46. The internal surface 39, and thus the bone plate 30, further defines a plurality of recessed regions 64 that are disposed circumferentially between respective adjacent ones of the threaded regions 62. Thus, the threaded regions 62 and the recessed regions 64 are alternately arranged with each other circumferentially about the central hole axis 45. The threaded regions 62 and the recessed regions 64 are configured such that the VA locking screws 43 are configured to threadedly purchase with the internal surface 39 at the threaded regions 62 without threadedly purchasing with the internal surface 39 at the at least one recessed regions 64.

**[0023]** In one example, the at least one thread 46 projects out from the internal surface 39 at the threaded regions 62 into the VA locking hole 54 generally toward the central hole axis 45. The at least one thread 46 can be monolithic with the internal surface 39. The at least one thread 46 can extend along a thread path. The thread path can be a helical thread path. In one example, the at least one thread 46 can be a single lead thread, a double lead thread, or any suitably constructed thread as desired. The internal surface 39 can further define a recess 48 at each of the recessed regions 64. The recesses 48 can circumferentially interrupt the at least one thread 46 so as to define a plurality of thread segments 60. Axially aligned ones of the thread segments can combine to define a plurality of threaded columns 50. Thus, it can be said that the threaded columns 50 are defined by thread segments 60. Because the at least one thread 46 can extend along a helical thread path, the threaded columns 50 can have different numbers of thread segments 60. The recesses 48 and the columns 50 can be alternately arranged with each other circumferentially about the central hole axis 45. The at least one recess 48 is offset with respect to the columns 50 of thread segments 60 in a radially outward direction. The internal surface 39 can be said to define a recessed surface 61 at the recesses 48.

**[0024]** The axial direction is defined as a direction be-

tween the outer surface 36 and the inner surface 34 of the bone plate 30. Thus, the directional term "axially inward" and derivatives thereof as used herein refers to a direction from the outer surface 36 toward the inner surface 34. Conversely, the terms "axially outward" and derivatives thereof as used herein refers to a direction from the inner surface 34 toward the outer surface 36. The axially inward and axially outward directions can be oriented along the central hole axis 45. Alternatively, the axially inward and axially outward directions can be oriented along a direction oblique to the central hole axis 45, for instance when used with reference to the internal surface 39.

**[0025]** The recesses 48 can have a radial depth sufficient such that the recessed surface 61 is recessed with respect to the internal surface 39 at the columns 50 along the radially outward direction. That is, the recessed surface 61 can define a radial distance from the central hole axis 45 that is greater than the radial distance from the central hole axis 45 to the major diameter of the at least one thread 46 of the columns 50. Therefore, during operation, a threaded bone screw head 33 that threadedly purchases with the internal surface 39 at the columns 50 of thread segments 60 are spaced radially inward from the internal surface 39 at the recess 48. The recessed surfaces 61 can be devoid of the thread 46. For instance, the recessed surfaces 61 can be unthreaded and smooth.

**[0026]** The thread segments 60 of each of the columns 50 are spaced from each other in the axial direction so as to define interstices that receive corresponding external threads of a locking screw head 33. The axially aligned thread segments 60 of at least a portion of the axial lengths of the columns 50 can each have a common circumferential length. In one example, all thread segments 60 of each of the columns 50 can have the same circumferential length. Accordingly, lines along circumferentially ends of the columns 50 can lie in respective planes that also include the central hole axis 45.

**[0027]** Thus, the thread segments 60 of each of the columns 50 can be circumferentially offset from the thread segments 60 of the other ones of the columns 50. Further, adjacent ones of the circumferentially spaced thread segments 60 can be separated by a respective common one of the recesses 48. Thus the thread segments 60 of each column 50 can be aligned with the thread segments 60 of one or both adjacent column 50 along the thread path. Because the thread path can be helical, the thread segments 60 can be aligned with the thread segments 60 of an adjacent one of the columns 50 along a helical path. In one example, each of the thread segments 60 of a respective one of the columns 50 is aligned along the thread path with 1) one the thread segments 60 a first adjacent column 50, and 2) one the thread segments 60 of a second adjacent column 50. Thus, the respective one of the columns 50 is disposed circumferentially between the first adjacent column 50 and the second adjacent column 50. Further, the thread

segments 60 of the respective one of the columns 50 is disposed between the first one of the thread segments 60 and the second one of the thread segments 60 with respect to the axial direction.

**[0028]** In one example, the bone plate 30 can include three recesses 48 illustrated as a first recess 48a, a second recess 48b, and a third recess 48c. The recesses 48 are circumferentially spaced apart from each other. However, it is appreciated that the bone plate 30 can include any number of recesses 48, greater than one, as desired, so as to define the variable angle locking hole 54 of the type described herein. Further, the respective constant distance of the recessed surfaces 61 of each of the recesses 48 can be the same as each other. In this regard, each of the recesses 48 can be substantially (within manufacturing tolerance) identical to each other. Further, the recesses 48 can be circumferentially equidistantly spaced from each other about the central hole axis 45. Alternatively, the recesses 48 can be circumferentially spaced from each other at a variable distance about the central hole axis 45.

**[0029]** Similarly, the bone plate 30 can include three columns 50 of thread segments 60 illustrated as a first column 50a, a second column 50b, and a third column 50c. The columns 50 are circumferentially spaced apart from each other. However, it is appreciated that the bone plate 30 can include any number of columns 50, greater than one, as desired, so as to define the variable angle locking hole 54 of the type described herein. The columns 50 can be substantially (within manufacturing tolerance) identical to each other. Further, the columns 50 can be circumferentially equidistantly spaced from each other about the central hole axis 45. Alternatively, the columns 50 can be circumferentially spaced from each other at a variable distance about the central hole axis 45. As will be appreciated from the description below, the three equidistantly spaced columns 50 allows for the bone plate 30 to mate with the VA threaded head 59 of the VA locking screw 43 (see Fig. 1B) in the VA locking hole 54 at an angle within a range of angles, such that the threaded head threadedly purchases with all of the columns 50 of thread segments 60 simultaneously. The angle can be one of numerous angles within the range of angles that are oblique to the central hole axis 45. Otherwise stated, the columns 50 allow the VA locking screw 43 to achieve a form fit in the VA locking hole 54. Further, the thread segments 60 that are purchased with the VA threaded head 59 can undergo a slight elastic and/or plastic deformation at their respective roots when the harder VA threaded head 59 is locked in the softer VA locking hole 54. The form fit increases the reliability of purchase between the VA locking screw 43 and the bone plate 30 in the VA locking hole 54.

**[0030]** Referring now to Fig. 4 in particular, the internal surface 39 defines a plurality of transition regions 67 that extend circumferentially between the columns 50 and the adjacent recessed regions 64, and in particular between the columns 50 and the adjacent recessed surfaces 61.

The thread segments 60 taper as the internal surface 39 extends circumferentially away from the columns 50 to the transition regions 67. Thus, the respective radial depths of the thread segments 60 decrease along the transition regions 67 in a circumferential direction away from the respective columns 50 and toward the respective recessed surface 61. The thread segments 60 of each of the columns 50 can have a constant radial depth. The transition regions 67 can define a circumferential length greater than that of the columns 50. The gradual transition from the columns 50 to the recessed surfaces 61 can assist in the reduction of cross-threading during operation.

**[0031]** It should be appreciated that because each of the columns 50 is disposed circumferentially between respective recessed surfaces 61, the inner surface 39 can define first and second transition regions 67 that extend circumferentially from each column 50 to the respective adjacent recessed surface 61. The first transition region 67 can extend from a first circumferential end of the columns 50 toward a first adjacent recessed surface 61, and the second transition region 67 can extend from a second circumferential end of the columns 50 toward a second adjacent recessed surface 61. The respective first and second circumferential ends of each of the columns 50 are circumferentially opposite each other.

**[0032]** The transition regions 67 are sized and shaped to avoid cross-threading during operation. In particular, the transition regions 67 provide a smooth interface between the columns 50 and the recessed surfaces 61. Otherwise stated, the transition regions 67 do not define any sharp edges as they extend circumferentially along the thread path. In one example, the recessed surfaces 61 can define a curvature along a plane that is oriented normal to the central hole axis 45 from a first end circumferential end of the recessed surface 61 to a second circumferential end of the recessed surface 61 that is circumferentially opposite the first circumferential end of the recessed surface 61. For instance, curvature can be a constant curvature from the first end to the second end. The curvature of the internal surface 39 at the recessed surface 61 can continue through the transition regions 67 to the respective columns 50 along at least a portion of an axial entirety of the recessed surface 61. For instance, the curvature of the internal surface 39 at the recessed surface 61 can continue through the transition regions 67 to the respective columns 50 along an axial entirety of the recessed surface 61 that lies in a common plane with the columns 50, wherein the common plane is oriented normal to the central hole axis 45.

**[0033]** In one example, the recessed surface 61 extends along a circular path along the plane that is oriented normal to the central hole axis 45. Thus, the curvature can be defined by a radius that is swept in a plane oriented normal to the central hole axis 45. Further, the radius can be smaller than the radius from the central hole axis 45 to the internal surface 39. In one example, the same radius that defines each recessed surfaces 61 can also

define respective transition regions 67 of the columns 50 that are disposed adjacent opposite circumferential ends of the recessed surface 61. Thus, the transition regions 67 can extend along a concave path with respect to the central hole axis 45 in a plane oriented normal to the central hole axis 45.

**[0034]** As best shown in Figs. 2A-3, while the threaded regions 62 include respective columns 50 of threaded segments 60, it should be appreciated that the internal surface 39 need not be threaded along its entirety at locations axially aligned with the columns 50. For instance, the internal surface 39 can include a tapered lead-in surface 66 at the axially outer end of the VA locking hole 54. Further, the internal surface 39 can include a tapered undercut surface 68 at the axially inner end of the VA locking hole 54.

**[0035]** The lead-in surface 66 can flare radially outward as it extends in the axially outward direction. The lead-in surface 66 can further be devoid of the at least one thread 46. For instance, the lead-in surface 66 can be smooth. The lead-in surface 66 can extend circumferentially about the axially outer end of the VA locking hole 54. In one example, the lead-in surface 66 can extend circumferentially continuously and uninterrupted along a full revolution about the central hole axis 45. For instance, the lead-in surface 66 defines an axially outer end at the outer surface 36 of the bone plate 30. The lead-in surface 66 thus extends axially inward from its axially outer end to its axially inner end. At locations axially aligned with the columns 50, and thus axially aligned with the threaded regions 62, the axially inner end of the lead-in surface 66 can be defined by an axially outermost one of the thread segments 60 of the columns 50. At locations axially aligned with the recessed surfaces 61, and thus axially aligned with the recessed regions 64, the axially inner end of the lead-in surface 66 can be defined as an intersection between the lead-in surface 66 and the recessed surface 61. The intersection can be defined at the axially outermost end of the recessed surfaces 61. At locations axially aligned with the transition regions 67, the axially inner end of the lead-in surface 66 can be defined by an axially outermost one of the tapering thread segments 60 of the transition regions 67. The lead-in surface 66 can define a first axial length from the outer surface 36 to the columns 50, a second axial length from the outer surface 36 to the transition regions 67, and a third axial length from the outer surface 36 to the recessed surfaces 61. The first length can be greater than the second length. Further, the second length can be greater than the third length.

**[0036]** It is envisioned in other examples that the lead-in surface 66 can be discontinuous as it extends circumferentially about the central hole axis 45. For instance, the recessed surfaces 61 can extend to the outer surface 36. Thus, segments of the lead-in surface 66 can extend circumferentially along locations axially aligned with the columns 50 and the transition region 67, and not at locations axially aligned with at least portions or entireties of

the recessed surfaces 61. The continuous lead-in surface 66 or alternatively each segment of the lead-in surface 66 can have a circumferential length greater than that of the columns 50. A portion up to an entirety of the lead-in surface 66 can be linear along the axial direction. Alternatively or additionally, a portion up to an entirety of the lead-in surface 66 can be curved along the axial direction. For instance, a portion up to an entirety of the lead-in surface 66 can be concave along the axial direction. Alternatively or additionally, a portion up to an entirety of the lead-in surface 66 can be convex along the axial direction.

**[0037]** The outer surface 36 of the bone plate 30 can define an axially outer perimeter 70 of an axially outer opening 72 to the VA locking hole 54. Thus, the lead-in surface 66 or segments of the lead-in surface 66 can axially inward from the perimeter 70. In one example, the perimeter 70 can define a circle, though it should be appreciated that the outer perimeter 70 can define different geometric shapes as desired. A circle may be preferable in some examples because, as described in more detail below, a variable angle locking screw can threadedly purchase with the columns 50 at an angle relative to the central hole axis 45 within a range of angles at which the head 33 of the VA locking screw 41 can threadedly purchase with the columns 50. Thus, the outer perimeter 70 can surround a portion of the VA threaded head 59 when the VA threaded head 59 is purchased with the columns 50 at an angle within the range of angles.

**[0038]** The undercut surface 68 can flare radially outward as it extends in the axially inward direction. The undercut surface 68 can further be devoid of the at least one thread 46. For instance, the undercut surface 68 can be smooth. The undercut surface 68 can extend circumferentially about the axially inner end of the VA locking hole 54. In one example, the undercut surface 68 can extend circumferentially continuously and uninterrupted along a full revolution about the central hole axis 45. For instance, the undercut surface 68 can extend axially outward from the inner surface 34 of the bone plate 30. Thus, the undercut surface 68 has an axially inner end at the inner surface 34. The undercut surface 68 has an axially outer end opposite the axially inner end along the axial direction. At locations axially aligned with the columns 50, and thus axially aligned with the threaded regions 62, the axially outer end of the undercut surface 68 can be disposed at the axially innermost thread segment 60 of the columns 50. At locations axially aligned with the recessed surfaces 61, and thus axially aligned with the recessed regions 64, the axially outer end of the undercut surface 68 can be disposed at an intersection between the undercut surface 68 and the recessed surface 61. The intersection can be located at the axially innermost end of the recessed surfaces 61. At locations axially aligned with the transition regions 67, the axially outer end of the undercut surface 68 can be disposed at an axially innermost one of the tapering thread segments 60 of the transition regions 67. The undercut surface 68

can define a first axial length from the inner surface 34 to the columns 50, a second axial length from the inner surface 34 to the transition regions 67, and a third axial length from the inner surface 34 to the recessed surfaces 61. The first length can be greater than the second length. Further, the second length can be greater than the third length.

**[0039]** It is envisioned in other examples that the undercut surface 68 can be discontinuous as it extends circumferentially about the central hole axis 45. For instance, the recessed surfaces 61 can extend to the inner surface 34. Thus, segments of the undercut surface 68 can extend circumferentially along locations axially aligned with the columns 50 and the transition region 67, and not at locations axially aligned with at least portions or entireties of the recessed surfaces 61. The continuous undercut surface 68 or alternatively each segment of the undercut surface 68 can have a circumferential length greater than that of the columns 50. A portion up to an entirety of the undercut surface 68 can be linear along the axial direction. Alternatively or additionally, a portion up to an entirety of the undercut surface 68 can be curved along the axial direction. For instance, a portion up to an entirety of the undercut surface 68 can be concave along the axial direction. Alternatively or additionally, a portion up to an entirety of the undercut surface 68 can be convex along the axial direction.

**[0040]** The inner surface 34 of the bone plate 30 can define an axially inner perimeter 74 of an axially inner opening 76 to the VA locking hole 54. In one example, the inner perimeter 74 can define a circle, though it should be appreciated that the inner perimeter 74 can define different geometric shapes as desired. A circle may be preferable in some examples because, as described in more detail below, a VA locking screw 43 can threadedly purchase with the columns 50 at an angle relative to the central hole axis 45 within a range of angles at which the VA threaded head 59 of the VA locking screw 43 can threadedly purchase with the columns 50. The range of angles can be disposed within a cone. Thus, the undercut surface 68 or segments of the undercut surface 68 can provide clearance for the screw shaft at different angles within the range of angles.

**[0041]** In one example, the lead-in surface 66 defines a lead-in angle that is defined by the central hole axis 45 and a straight line 73 that intersects both the axially outer end of the lead-in surface 66 and the axially inner end of the lead-in surface 66. Further, the straight line 73 lies in a plane that includes the central hole axis 45 and intersects the lead-in surface 66. Thus, the lead-in angle can be defined by the central hole axis 45 and the straight line 73 whether the lead-in surface 66 is straight or curved. In one example, the lead-in angle can be between approximately 15 degrees and approximately 60 degrees. For instance, the lead in angle can be approximately 45 degrees in one example.

**[0042]** Similarly, the undercut surface 68 defines at least one undercut angle that is defined by the central



hole axis 45 and at least one straight line. The at least one straight line can be configured as first and second straight lines 77a and 77b, respectively. The first and second straight lines 77a and 77b can lie in a plane that includes the central hole axis 45 and intersects the undercut surface 68 at least at two locations. The first straight line 77a is disposed axially inward with respect to the second straight line 77b. Thus, the first straight line 77a can interface with the axially inner surface 34 of the bone plate 30. Thus, the at least one undercut angle can include first and second undercut angles whether the undercut surface 68 is straight or curved. The first undercut angle can be defined by the central hole axis 45 and the first straight line 77a. The second undercut angle can be defined by the central hole axis 45 and the second straight line 77b. In one example, the first undercut angle can be between approximately 15 degrees and approximately 60 degrees. For instance, the first undercut angle can be approximately 45 degrees. The second undercut angle can be at least approximately 15 degrees. For instance, the second undercut angle can be approximately 15 degrees so as to accommodate angulation of the VA screw shaft 35 within the range of angles described above.

**[0043]** It should be appreciated that the columns 50 can extend from the lead-in surface 66 to the undercut surface 68. Further, the columns 50 can taper radially inward toward the central hole axis 45 as they extend axially inward. In one example, the columns 50 can extend linearly along the axial direction from the lead-in surface 66 to the undercut surface 68. Further, the VA locking hole 54 can be constructed such that no portion of the internal surface 39 extends radially inward of the columns 50. Therefore, the VA locking screw 43 described herein can threadedly purchase within the columns 50 without contacting any other surface except for the columns 50 and the undercut surface 68. Each of the columns 50 can thus define a respective centerline 80 that is disposed circumferentially equidistantly from the circumferentially opposed ends of the respective column 50. The centerlines 80 of the columns 50 can lie in respective planes that also include the central hole axis 45. Further, the centerlines 80 can define an angle between 5 degrees and 30 degrees with respect to the central hole axis 45. In one example, the angle can be approximately 15 degrees.

**[0044]** The centerlines 80 can extend along the crests of the thread segments 60 of the respective columns 50. Alternatively, the centerlines 80 can extend along the roots of the thread segments 60 of the respective columns 50. The terms "approximately" and "substantially" as used herein with respect to dimensions and angles takes into account manufacturing tolerances. Further, the terms "approximately" and "substantially" can include 10% greater than or less than the stated dimension or angle. Further, the terms "approximately" and "substantially" can equally apply to the specific value stated.

**[0045]** The recessed surfaces 61 can also extend from

the lead-in surface 66 to the undercut surface 68. Further, the recessed surfaces 61 can taper radially inward toward the central hole axis 45 as they extend axially inward. In one example, the recessed surfaces 61 can extend linearly along the axial direction from the lead-in surface 66 to the undercut surface 68. Each of the recessed surfaces 61 can thus define a respective centerline 82 that is disposed circumferentially equidistantly from the circumferentially opposed ends of the respective recessed surfaces 61. The centerlines 82 of the recessed surfaces 61 can lie in respective planes that also include the central hole axis 45. Further, the centerlines 82 can define an angle between 5 degrees and 30 degrees with respect to the central hole axis 45. In one example, the angle can be approximately 15 degrees. Thus, the angle defined by the recessed surfaces 61 can be approximately equal to the angle defined by the columns 50. Otherwise stated, the centerlines 80 and at least one or more up to all of the centerlines 82 can be oriented at a common angle with respect to the central hole axis 45. Further, in one example, the common angles can be a constant angle along respective entireties of the axial lengths of the columns 50 and the recessed surfaces 61. In one example, the common angle can be between approximately 5 degrees and approximately 30 degrees.

**[0046]** Referring now to Figs. 5A-8C, the VA locking hole 54 is configured to receive a plurality of the bone screws 37 described above. For instance, as illustrated in Figs. 5A-5B, the bone screw 37 can be configured as a VA locking screw 43. The VA locking screw 43 is configured to threadedly mate with the bone plate 30 in the VA locking hole 54 at different orientations of the VA locking screw 43 with respect to the central hole axis 45. The VA threaded head 59 can be constructed in accordance with any embodiment as described in U.S. Patent No. 8,574,268. Thus, it is appreciated that the VA threaded head 59 of the VA locking screw 43 can define at least one external thread 78. The VA threaded head 59 of the VA locking screw 43 have a curved outer surface, which can be convex in one example. In particular, the outer surface can be spherical. Further, the external thread 78 of the VA threaded head 59 of the VA locking screw 43 can be circumferentially continuous about the central screw axis 53. It should be appreciated, however, that the VA threaded head 59 can be alternatively constructed in any manner desired so as to threadedly mate with the at least one thread 46 in the manner described herein.

**[0047]** Otherwise stated, the VA locking screw 43 is configured to be inserted into the VA locking hole 54 such that the central screw axis 53 is at one of a plurality of angles with respect to the central hole axis 45 within a range of angles at which the VA threaded head 59 is configured to threadedly mate with the at least one thread 46 in the VA locking hole 54. For instance, the VA locking screw 43 is configured to be inserted into the VA locking hole 54 such that the central screw axis 53 is at one of a plurality of angles within a range of angles defined by the central screw axis 53 and the central hole axis 45 at

which the VA threaded head 59 is configured to threadedly mate with each of the columns 50. The range of angles can be disposed within a cone that is centered about the central hole axis 45. Thus, the range of angles can be disposed within a cone of up to thirty degrees. The range of angles can be measured as 15 degrees with respect to the central hole axis 45. The central hole axis 45 can define the center of the cone. Thus, the VA threaded head 59 of the VA locking screw 43 can mate with the bone plate 30 in the manner described herein both when central screw axis 53 of the VA locking screw 43 is coincident with the central hole axis 45 and when the central screw axis 53 of the VA locking screw 43 is at any other angle with respect to the central hole axis 45 within the range of angles.

**[0048]** Thus, it can be said that the at least one thread 46 is configured to threadedly mate with the VA threaded head 59 while the VA locking screw 43 is inserted into the VA locking hole 54 such that the central screw axis 53 is oriented at a first angle with respect to the central hole axis 45, and the at least one thread 46 is further configured to threadedly mate with the VA threaded head 59 when the VA locking screw 43 is inserted into the VA locking hole 54 such that the central screw axis 53 is oriented at a second angle with respect to the central hole axis 45 that is different than the first angle. At least one or both of the first and second angles can be non-zero angles. Alternatively, the central screw axis 53 can be coincident with the central hole axis 45 in one of the orientations in the range of orientations. The at least one thread 46 and the threads of the VA threaded head 59 are defined prior to insertion of the VA locking screw 43 into the VA locking hole 54. That is, the internal surface 39 is not designed or configured to cut or form threads into the VA threaded head 59. Similarly, the VA threaded head 59 is not designed or configured to cut or form threads into the internal surface 39. It is recognized, however, that after locking of the VA locking screw 43 in the VA locking hole 54, the respective roots of the thread segments 60 that are mated with the VA threaded head 59 can undergo a small amount of elastic and/or plastic deformation. The dimensions, angles, and characteristics of the VA locking hole 54 described herein, alone and in combination, are configured to minimize cross-threading of the VA threaded head 59 of the VA locking screw 43 when mating with the at least one thread 46 of the VA locking hole 54.

**[0049]** Referring again to Figs. 6A-6C, the VA locking hole 54 is configured to receive the VA locking screw 43 such that each of the columns 50 threadedly purchase with the externally threaded VA threaded head 59 of the VA locking screw 43 when the central screw axis 53 and the central hole axis 45 define any angle within the range of angles that are disposed within the cone. In particular, the first column 50a threadedly purchases with the externally threaded VA threaded head 59 of the VA locking screw 43, the second column 50b threadedly purchases with the externally threaded VA threaded head 59 of the

VA locking screw 43, and the third column 50c threadedly purchases with the externally threaded VA threaded head 59 of the VA locking screw 43. While different numbers of thread segments 60 of each of the columns 50a, 50b, and 50c can threadedly purchase with the externally threaded VA threaded head 59 of the VA locking screw 43 depending on the angle defined by the central screw axis 53 and the central hole axis 45, it can nonetheless be said that the VA threaded head 59 is form fit in the VA locking hole 54.

**[0050]** Thus, the thread segments 60 of the columns 50 and the external thread 78 of the VA threaded head 59 of the VA locking screw 43 can be configured to threadedly purchase with each other. In one example, the external thread 78 of the VA threaded head 59 of the VA locking screw 43 defines a respective thread angle, and the thread segments 60 of the columns 50 define a respective thread angle. In one example, the thread angle of the thread segments 60 can be greater than the thread angle of the external thread 78 of the VA threaded head 59 of the VA locking screw 43. For instance, the thread angle of the thread segments 60 can be in the range of approximately 70 degrees and approximately 89 degrees. For instance, the thread angle of the thread segments 60 can be approximately 80 degrees. The thread angle of the external thread 78 of the VA threaded head 59 of the VA locking screw 43 can be in the range of approximately 50 degrees and approximately 70 degrees. For instance, the thread angle of the external thread 78 of the VA threaded head 59 of the VA locking screw 43 can be approximately 60 degrees. Thus, the thread angle of the thread segment 60 and the external thread 78 of the VA threaded head 59 of the VA locking screw 43 can define a ratio between approximately 1:1 and 1.8:1. For instance, the ratio can be approximately 4:3.

**[0051]** Referring now to Figs. 7A-7B, the VA locking hole 54 is further configured to mate with the threaded head 33 of the standard-type locking screw 51. That is, each of the columns 50 can purchase with the threaded head 33 of the standard-type locking screw 51 when the standard-type locking screw 51 is oriented at the nominal orientation. Thus, the central screw axis 53 is at a predetermined orientation with respect to the central hole axis 45, and at no other orientations with respect to the central hole axis 45. The predetermined orientation can be achieved when the central screw axis 53 is substantially coincident with the central hole axis 45. It can therefore be said that the VA locking hole 54 can be configured to selectively mate with the VA locking screw 43 and the standard-type locking screw 51.

**[0052]** Thus, it is appreciated that the head 33 of the standard-type locking screw 51 can define at least one external thread 84. The external thread 84 of the head 33 of the standard-type locking screw 51 can be circumferentially continuous about the central screw axis 53. It should be appreciated, however, that the head 33 can be alternatively constructed in any manner desired so as

to threadedly mate with the at least one thread 46 in the manner described herein. In one example, the external surface of the head 33 of the standard-type locking screw 51 can be tapered radially inwardly as it extends along the axially inward direction. For instance, the external surface of the head 33 of the standard-type locking screw 51 can extend linearly in the axially inward direction. Thus, the head 33 of the standard-type locking screw 51 can be conical in shape. The threaded external surface of the head 33 of the standard-type locking screw 51 can define a slope 86 that lies in a respective plane that also includes the central screw axis 53. Further, the slope 86 can define an angle between 5 degrees and 25 degrees with respect to each of the central hole axis 45 and the screw axis 53, it being appreciated that the screw axis 53 is coincident with the central hole axis 45 when the standard-type locking screw 51 is mated with the bone plate 30 in the VA locking hole 54. In one example, the angle of the slope 86 can be approximately 10 degrees.

**[0053]** The slope 86 can extend along the crests of the at least one external thread 84. Alternatively, slope 86 can extend along the roots of the at least one external thread 84. Accordingly, the slope 86 can be oriented substantially parallel with the centerlines 80 of the columns 50. Further, the slope 86 can be oriented oblique with respect to the centerlines 80 of the recessed surfaces 61. Alternatively, it is recognized that the slope 86 can be oriented substantially parallel with the centerlines 80 of the recessed surfaces 61.

**[0054]** Referring now to Figs. 8A-8C, the bone plate 30 can include a combination hole 90 that includes both the VA locking hole 54 and the compression hole 52. Thus, the internal surface 39 of the combination hole 90 can define both the VA locking hole 54 and the compression hole 52. The VA locking hole 54 and the compression hole 52 of the combination hole 90 can be open to each other along a direction that is perpendicular to one or both of the central hole axis 45 of the VA locking hole 54 and the central hole axis 45 of the compression hole 52. The central hole axis 45 of the VA locking hole 54 and the compression hole 52 of the combination hole 90 can be aligned with each other along the longitudinal L and thus along the central axis of the bone plate 30, or along any suitable alternative direction as desired.

**[0055]** The internal surface 39 of the bone plate 30 can thus also define the compression surface 57 of the compression hole 52 of the combination hole 90. Thus, the axially outer perimeter 70 can define the axially outer opening 72 to each of the VA locking hole 54 and the unthreaded compression hole 52 that is open to the VA locking hole 54. Similarly, the axially inner perimeter 74 can define the axially inner opening 76 to each of the VA locking hole 54 and the unthreaded compression hole 52 that is open to the VA locking hole 54.

**[0056]** The compression surface 57 can extend between the outer surface 36 and the inner surface 34 as described above. In one example, the internal compression surface 57 can extend to the outer surface 36. Al-

ternatively, the lead-in surface 66 can extend from the internal compression surface 57 to the outer surface 36. Further, the internal surface 39 of the compression hole 52 can define the undercut surface 68 as described above with respect to the VA locking hole 54. At least a portion up to an entirety of the compression surface 57 can be unthreaded. Accordingly, the unthreaded compression head 58 of the compression screw 49 is configured to bear against the bone plate 30, and in particular the compression surface 57, in the compression hole 52 so as to apply a compressive force against the bone plate 30 toward the underlying bone 22.

**[0057]** In one example, the compression surface 57 can be concave in the axial direction with respect to the central hole axis 45 of the compression hole 52. For instance, the compression surface 57 can be dish shaped or spherical. Thus, the compression surface 57 can be configured to be placed in surface contact with the compression head 58 of the compression screw 49. Alternatively, the compression surface 57 can be linear in the axial direction as it tapers radially inwardly toward the central hole axis 45.

**[0058]** During operation, the shaft 35 of the compression screw 49 can be inserted through the compression hole 52 of the combination hole 90 and driven into the underlying bone 22 as described above. For instance, the compression screw 49 can be inserted into the compression hole 52 such that the central screw axis 53 is oriented at any angle with respect to the central hole axis 45 within the range of angles described above. Rotation of the compression screw 49 while the shaft 35 is threadedly purchased with the underlying bone 22 causes the compression head 58 to bear against the compression surface 57, and thus the internal surface 39, so as to apply a compression force to the bone plate 30 that, in turn, becomes compressed against the underlying bone 22.

**[0059]** Thus, it should be appreciated that the combination hole 90 is configured to selectively receive the compression screw 49, the VA locking screw 43 described above with reference to Figs. 6A-6C, and the standard-type locking screw 51 described above with reference to Figs. 7A-7B, so as to fix the bone plate 30 to the underlying bone 22. The internal surface 39 of the combination hole 90 can define a neck 92 at an interface between the VA locking hole 54 and the compression hole 52. Two of the columns 50 of the VA locking hole 54 of the combination hole 90 can extend circumferentially to the neck 92. The recess 48 between the two of the columns 50 can thus extend into the compression hole 52. The VA locking hole 54 of the combination hole 90 is otherwise as described above with respect to Figs. 1A-6C.

## Claims

1. A bone plate (30) comprising:

an inner surface (34) configured to face the underlying bone (22), and an outer surface (36) opposite the inner surface (34); and an internal surface (39) that extends from the outer surface (36) to the inner surface (34) so as to define a hole (54) that is oriented along a central hole axis (45), wherein the internal surface (39) includes 1) a plurality of threaded regions (62) that define respective columns (50) of thread segments (60), and 2) a plurality of recessed surfaces (61) that are disposed between respective adjacent ones of the thread segments (60), the recessed surfaces (61) being offset radially outward with respect to the columns (50) of thread segments (60), wherein the bone plate (30) is configured to mate with a threaded head (59) of a variable angle locking screw (43) in the hole (54) at an angle within a range of angles, such that the threaded head (59) threadedly purchases with all of the columns (50) of thread segments (60), and wherein the angle is oblique to the central hole axis (45),

**characterized in that**

the internal surface (39) defines a plurality of transition regions (67) between the columns (50) and respective adjacent ones of the recessed surfaces (61), and wherein respective depths of the thread segments (60) taper along the transition regions (67) in a circumferential direction away from the respective columns (50) to the respective recessed surface (61).

2. The bone plate (30) as recited in claim 1, wherein the recessed surfaces (61) are offset radially outward with respect to respective the threaded regions (62).
3. The bone plate (30) as recited in claim 1, wherein the internal surface (39) defines a lead-in surface (66) that is tapered radially inward from the outer surface (36) to the columns (50).
4. The bone plate (30) as recited in claim 1, further comprising an undercut surface (68) that is tapered radially outward as it extends from the columns (50) to the inner surface (34) tapered that extends from the respective axially inner ends of the columns (50) to the inner surface (34).
5. The bone plate (30) as recited in claim 1, wherein the outer surface (36) defines a perimeter (70) of an opening to the hole (54), and the perimeter (70) defines a circle.
6. The bone plate (30) as recited in any one of claims 1 to 5, wherein the recessed surfaces (61) are

smooth.

7. The bone plate (30) as recited in any one of claims 1 to 6, wherein the recessed surfaces (61) are defined by respective radii that also define at least a portion of the transition regions (67).
8. The bone plate (30) as recited in any one of claims 1 to 7, wherein the recessed surfaces (61) and the columns (50) define respective centerlines (80) that are each oriented at a common angle with respect to the central hole axis (45).
9. The bone plate (30) as recited in claim 8, wherein the common angle is between approximately 5 degrees and approximately 30 degrees.
10. The bone plate (30) as recited in any one of claims 1 to 9, wherein no portion of the internal surface (39) extends radially inward of the columns (50) and/or wherein the range of angles is within a cone that is centered about the central hole axis (45).
11. The bone plate (30) as recited in any one of claims 1 to 10, wherein the hole (54) is open to a compression hole (52) that is configured to receive a compression screw (49) having an unthreaded head that bears against the interior surface (39) so as to compress the bone plate (30) against the underlying bone (22).
12. A system (20) comprising:
  - the bone plate (30) as recited in claim 1; and
  - the variable angle locking screw (43) recited in claim 1.
13. The system (20) as recited in claim 12, wherein the thread segments (60) of the bone plate (30) define a thread angle, the threaded head (59) of the variable angle locking screw (43) defines a thread angle, and the thread angle of the thread segments (59) is greater than the thread angle of the threaded head (59).
14. The system (20) as recited in claim 13, wherein the thread angle of the thread segments (60) of the bone plate (30) and the thread angle of the threaded head (59) of the variable angle locking screw (43) define a ratio between greater than 1:1 and up to 1.8:1.
15. The system (20) as recited in claim 13, wherein the thread angle of the thread segments (60) of the bone plate (30) is approximately 80 degrees, and the thread angle of the threaded head (59) of the variable angle locking screw (43) is approximately 60 degrees.

## Patentansprüche

### 1. Knochenplatte (30), umfassend:

eine Innenseite (34), die dem darunter liegenden Knochen (22) zugewandt konfiguriert ist, und eine Außenseite (36), die der Innenseite (34) gegenüberliegt; und

eine Innenfläche (39), die sich von der Außenseite (36) zur Innenseite (34) erstreckt, um eine Öffnung (54) zu bilden, die entlang einer Öffnungsmittelachse (45) ausgerichtet ist, wobei die Innenfläche (39) 1) eine Vielzahl von Gewindebereichen (62), die jeweilige Reihen (50) von Gewindegsegmenten (60) definieren, und 2) eine Vielzahl von vertieften Flächen (61) umfasst, die zwischen jeweils benachbarten der Gewindegsegmenten (60) angeordnet sind, wobei die vertieften Flächen (64) in Bezug auf die Reihen (50) der Gewindegsegmente (60) radial nach außen versetzt sind,

wobei die Knochenplatte (30) so konfiguriert ist, dass diese mit einem Gewindekopf (59) einer winkelverstellbaren Feststellschraube (43) in der Öffnung (54) in einem Winkel innerhalb eines Winkelbereichs zusammenpasst, sodass der Gewindekopf (59) mit allen Reihen (50) der Gewindegsegmente (60) ineinandergreift, und wobei der Winkel schräg zur Öffnungsmittelachse (45) verläuft,

**dadurch gekennzeichnet, dass**

die Innenfläche (39) eine Vielzahl von Übergangsbereichen (67) zwischen den Reihen (50) und jeweils benachbarten der vertieften Flächen (61) definiert, und

wobei sich jeweilige Tiefen der Gewindegsegmente (60) entlang der Übergangsbereiche (67) in Umfangsrichtung von den jeweiligen Reihen (50) zu der jeweiligen vertieften Fläche (61) hin verjüngen.

2. Knochenplatte (30) nach Anspruch 1, wobei die vertieften Flächen (61) in Bezug auf die jeweiligen Gewindebereiche (62) radial nach außen versetzt sind.

3. Knochenplatte (30) nach Anspruch 1, wobei die Innenfläche (39) eine Einführfläche (66) definiert, die sich von der Außenseite (36) zu den Reihen (50) radial nach innen verjüngt.

4. Knochenplatte (30) nach Anspruch 1, die ferner eine Hinterschnittfläche (68) umfasst, die sich radial nach außen verjüngt, während diese sich von den Reihen (50) bis zur konischen Innenseite (34) erstreckt, die sich von den jeweiligen axial inneren Enden der Reihen (50) zur Innenseite (34) erstreckt.

5. Knochenplatte (30) nach Anspruch 1, wobei die Au-

ßenseite (36) einen Umfang (70) einer Mündung bis zur Öffnung (54) definiert und der Umfang (70) einen Kreis definiert.

5 6. Knochenplatte (30) nach einem der Ansprüche 1 bis 5, wobei die vertieften Flächen (61) glatt sind.

7. Knochenplatte (30) nach einem der Ansprüche 1 bis 6, wobei die vertieften Flächen (61) durch jeweilige Radien definiert sind, die auch zumindest einen Abschnitt der Übergangsbereiche (67) definieren.

8. Knochenplatte (30) nach einem der Ansprüche 1 bis 7, wobei die vertieften Flächen (61) und die Reihen (50) jeweilige Mittellinien (80) definieren, die jeweils in einem gemeinsamen Winkel in Bezug auf die Öffnungsmittelachse (45) ausgerichtet sind.

9. Knochenplatte (30) nach Anspruch 8, wobei der gemeinsame Winkel zwischen etwa 5 Grad und etwa 30 Grad liegt.

10. Knochenplatte (30) nach einem der Ansprüche 1 bis 9, wobei sich kein Abschnitt der Innenfläche (39) von den Reihen (50) radial nach innen erstreckt, und/oder wobei der Bereich der Winkel innerhalb eines Kegels liegt, der um die Öffnungsmittelachse (45) zentriert ist.

11. Knochenplatte (30) nach einem der Ansprüche 1 bis 10, wobei die Öffnung (54) in einer Kompressionsöffnung (52) mündet, die zum Aufnehmen einer Kompressionsschraube (49) mit einem gewindelosen Kopf konfiguriert ist, der an der Innenfläche (39) anliegt, um die Knochenplatte (30) gegen den darunter liegenden Knochen (22) zu drücken.

12. System (20), umfassend:

die Knochenplatte (30) nach Anspruch 1; und die winkelverstellbare Feststellschraube (43) nach Anspruch 1.

13. System (20) nach Anspruch 12, wobei die Gewindegsegmente (60) der Knochenplatte (30) einen Gewindegwinkel definieren, der Gewindekopf (59) der winkelverstellbaren Feststellschraube (43) einen Gewindegwinkel definiert, und der Gewindegwinkel der Gewindegsegmente (59) größer als der Gewindegwinkel des Gewindekopfes (59) ist.

14. System (20) nach Anspruch 13, wobei der Gewindegwinkel der Gewindegsegmente (60) der Knochenplatte (30) und der Gewindegwinkel des Gewindekopfes (59) der winkelverstellbaren Verriegelungsschraube (43) ein Verhältnis zwischen größer als 1:1 und bis zu 1,8: 1 definieren.

15. System (20) nach Anspruch 13, wobei der Gewindevinkel der Gewindegsegmente (60) der Knochenplatte (30) etwa 80 Grad beträgt und der Gewindevinkel des Gewindekopfes (59) der winkelverstellbaren Feststellschraube (43) etwa 60 Grad beträgt.

## Revendications

1. lame osseuse (30), comprenant :

une surface intérieure (34) configurée pour faire face à l'os sous-jacent (22), et une surface extérieure (36) face à la surface intérieure (34), et une surface interne (39), laquelle s'étend de la surface extérieure (36) à la surface intérieure (34) de manière à définir un trou (54), lequel est orienté le long d'un axe de trou central (45), dans laquelle la surface interne (39) inclut 1) une pluralité de régions filetées (62), lesquelles définissent des colonnes respectives (50) de segments de filet (60), et 2) une pluralité de surfaces en retrait (61), lesquelles sont disposées entre des segments adjacents respectifs de segments de filet (60), les surfaces en retrait (64) étant décalées de manière radiale et vers l'extérieur par rapport aux colonnes (50) de segments de filet (60),

dans laquelle la lame osseuse (30) est configurée pour s'accoupler avec une tête filetée (59) d'une vis de blocage à angle variable (43) dans le trou (54) suivant un angle dans les limites d'une plage d'angles, de telle sorte que la tête filetée (59) vient en prise par filetage avec toutes les colonnes (50) des segments de filet (60), et dans laquelle l'angle est oblique par rapport à l'axe de trou central (45),

### caractérisée en ce que

la surface interne (39) définit une pluralité de régions de transition (67) entre les colonnes (50) et des surfaces adjacentes respectives des surfaces en retrait (61), et

dans laquelle des profondeurs respectives des segments de filet (60) présentent un amincissement progressif le long des régions de transition (67) dans une direction circonférentielle s'éloignant des colonnes respectives (50) vers la surface en retrait respective (61).

2. lame osseuse (30) selon la revendication 1, dans laquelle les surfaces en retrait (61) sont décalées de manière radiale et vers l'extérieur par rapport aux régions filetées (62).

3. lame osseuse (30) selon la revendication 1, dans laquelle la surface interne (39) définit une surface d'introduction (66), laquelle présente un amincissement progressif de manière radiale et vers l'intérieur

de la surface extérieure (36) vers les colonnes (50).

4. lame osseuse (30) selon la revendication 1, comprenant en outre une surface de contre-dépouille (68), laquelle présente un amincissement progressif de manière radiale et vers l'extérieur à mesure qu'elle s'étend des colonnes (50) vers la surface intérieure (34) avec un amincissement progressif s'étendant des extrémités intérieures de manière axiale respectives des colonnes (50) vers la surface intérieure (34).

5. lame osseuse (30) selon la revendication 1, dans laquelle la surface extérieure (36) définit un périmètre (70) d'une ouverture vers le trou (54), et le périmètre (70) définit un cercle.

6. lame osseuse (30) selon l'une quelconque des revendications 1 à 5, dans laquelle les surfaces en retrait (61) sont lisses.

7. lame osseuse (30) selon l'une quelconque des revendications 1 à 6, dans laquelle les surfaces en retrait (61) sont définies par des rayons respectifs, lesquels définissent également au moins une portion des régions de transition (67).

8. lame osseuse (30) selon l'une quelconque des revendications 1 à 7, dans laquelle les surfaces en retrait (61) et les colonnes (50) définissent des lignes centrales respectives (80), lesquelles sont chacune orientées suivant un angle commun par rapport à l'axe de trou central (45).

9. lame osseuse (30) selon la revendication 8, dans laquelle l'angle commun est compris entre approximativement 5 degrés et approximativement 30 degrés.

10. lame osseuse (30) selon l'une quelconque des revendications 1 à 9, dans laquelle aucune portion de la surface interne (39) ne s'étend de manière radiale vers l'intérieur des colonnes, et/ou dans laquelle la plage d'angles est comprise dans les limites d'un cône, lequel est centré autour de l'axe de trou central (45).

11. lame osseuse (30) selon l'une quelconque des revendications 1 à 10, dans laquelle le trou (54) est ouvert vers un trou de compression (52), lequel est configuré pour recevoir une vis de compression (49) présentant une tête non filetée, laquelle appuie contre la surface intérieure (39) de manière à comprimer la lame osseuse (30) contre l'os sous-jacent (22).

12. système (20), comprenant :

la lame osseuse (30) selon la revendication 1, et

la vis de blocage à angle variable (43) selon la revendication 1.

13. Système (20) selon la revendication 12, dans lequel les segments de filet (60) de la lame osseuse (30) définissent un angle de filet, la tête filetée (59) de la vis de blocage à angle variable (43) définit un angle de filet, et l'angle de filet des segments de filet (59) est supérieur à l'angle de filet de la tête filetée (59). 5 10
14. Système (20) selon la revendication 13, dans lequel l'angle de filet des segments de filet (60) de la lame osseuse (30) et l'angle de filet de la tête filetée (59) de la vis de blocage à angle variable (43) définissent un rapport égal à une valeur supérieure à 1 : 1 et allant jusqu'à 1,8 : 1. 15
15. Système (20) selon la revendication 13, dans lequel l'angle de filet des segments de filet (60) de la lame osseuse (30) est approximativement égal à 80 degrés, et l'angle de filet de la tête filetée (59) de la vis de blocage à angle variable (43) est approximativement égal à 60 degrés. 20

25

30

35

40

45

50

55

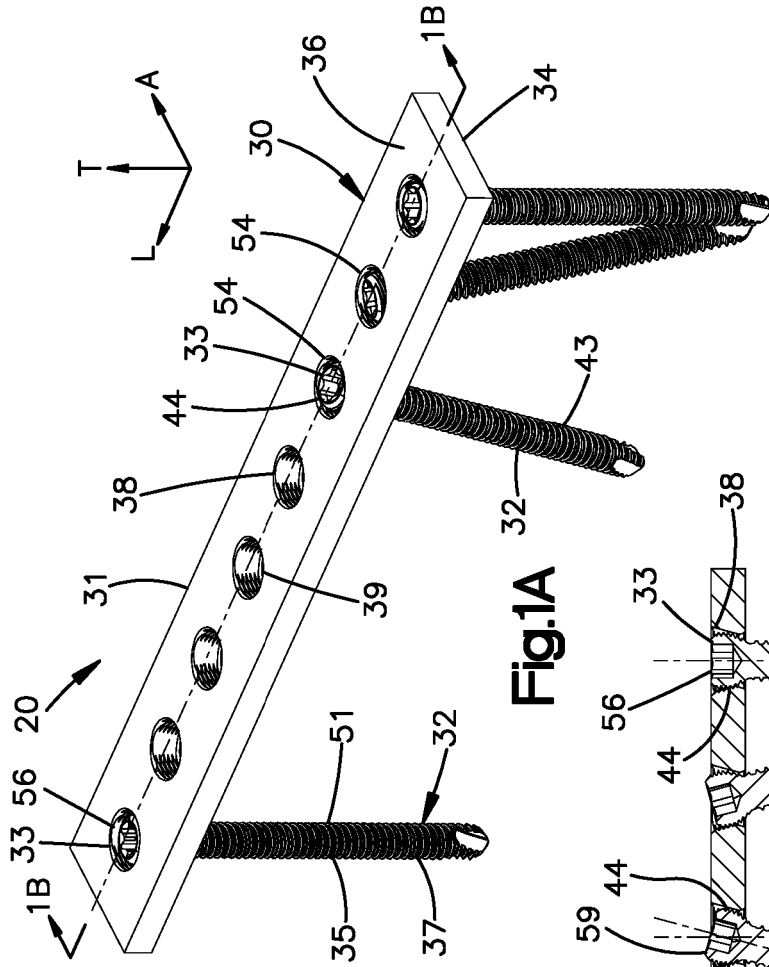


Fig.1A

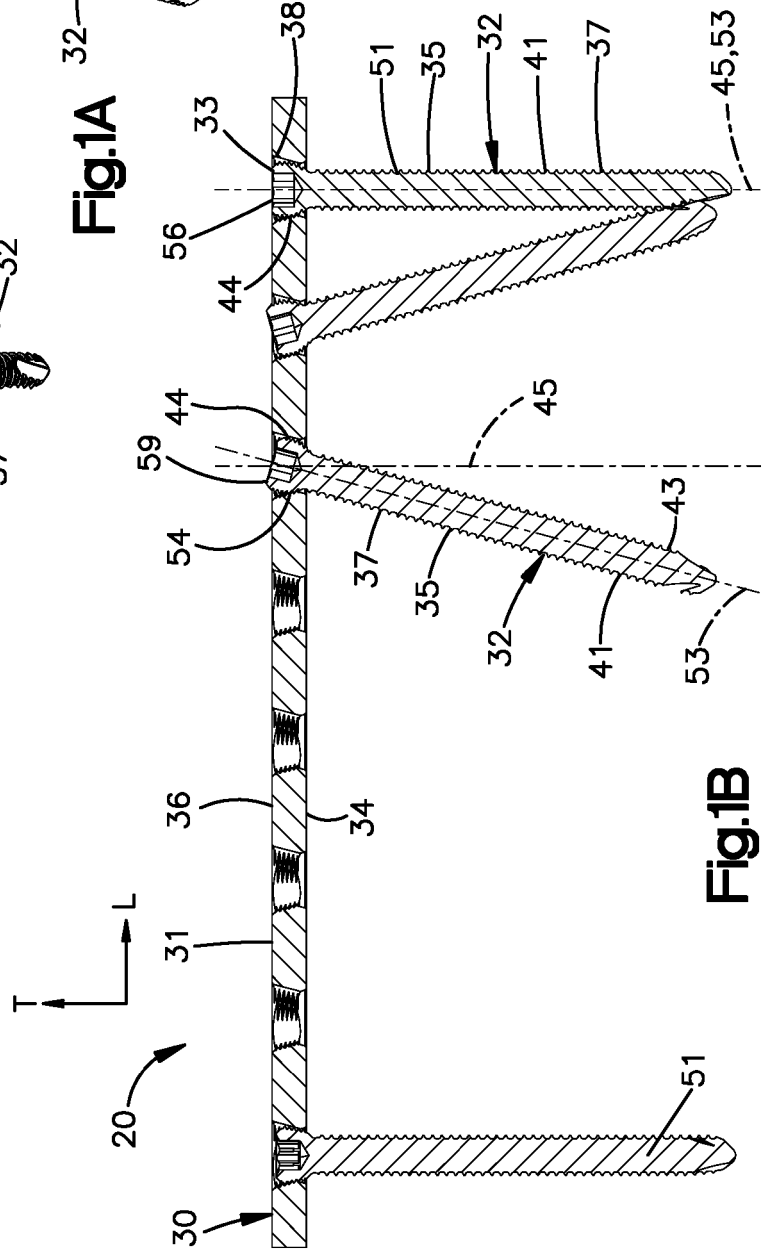
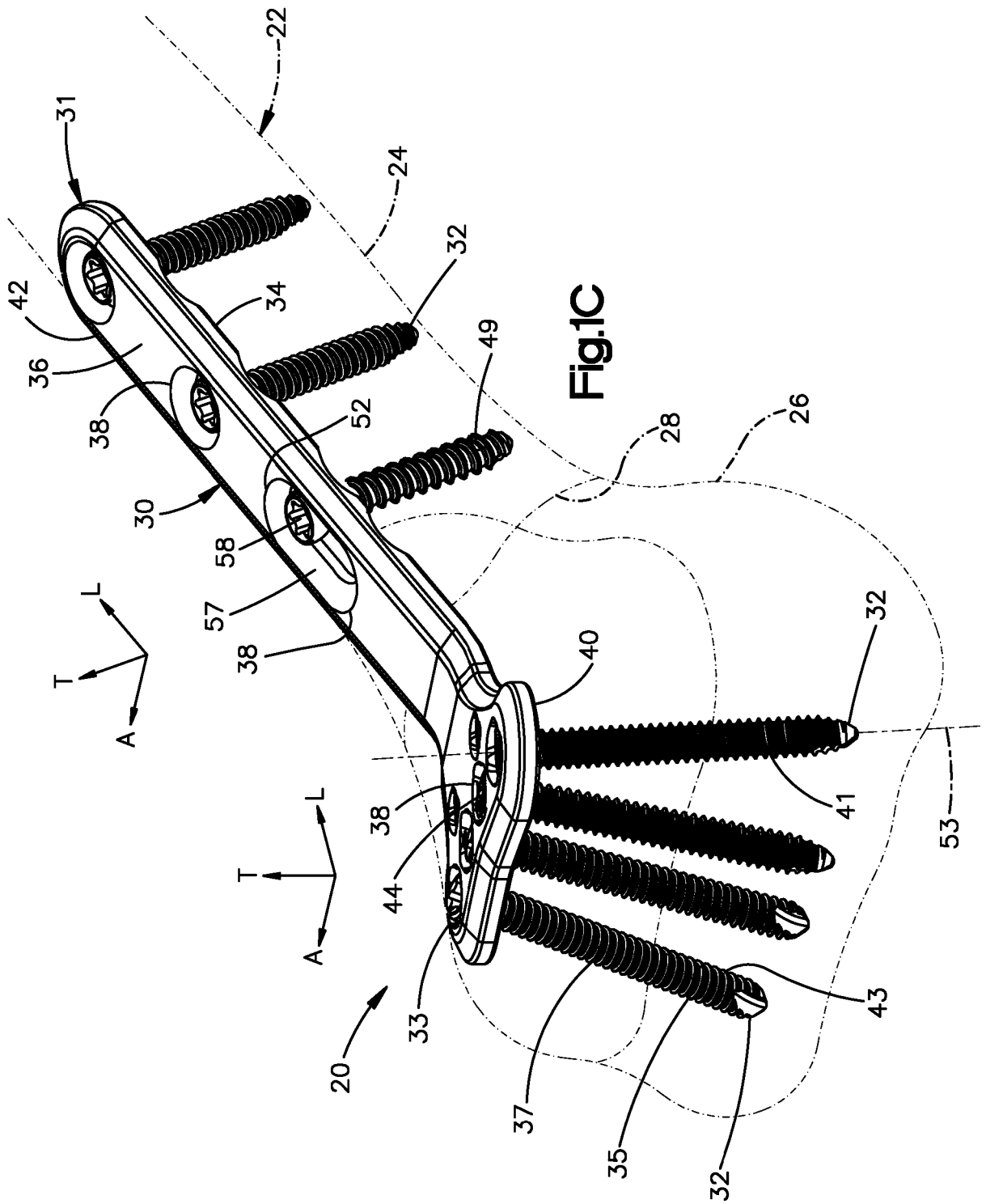
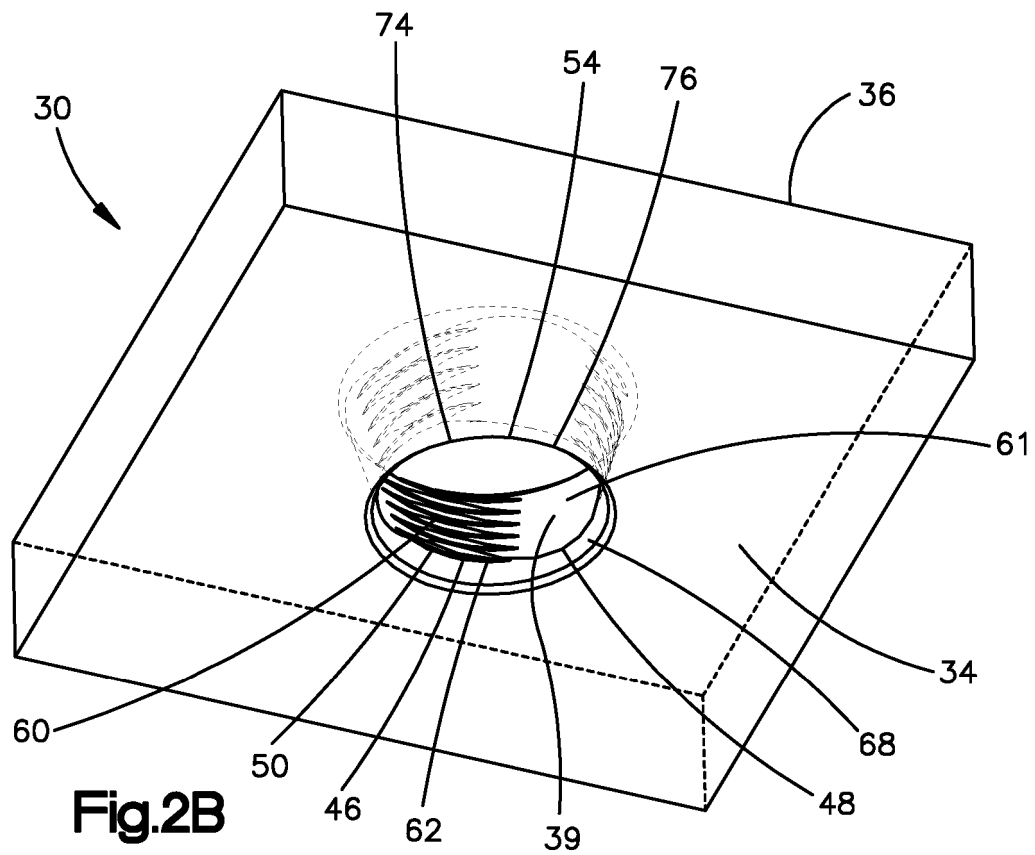
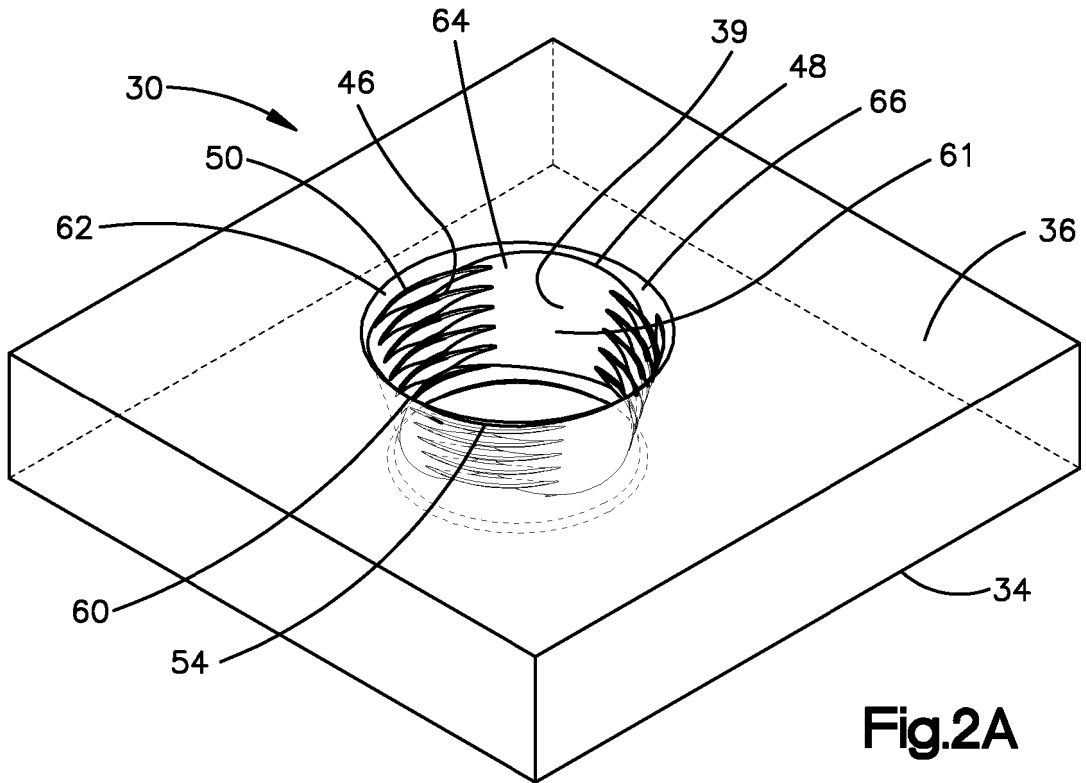


Fig.1B







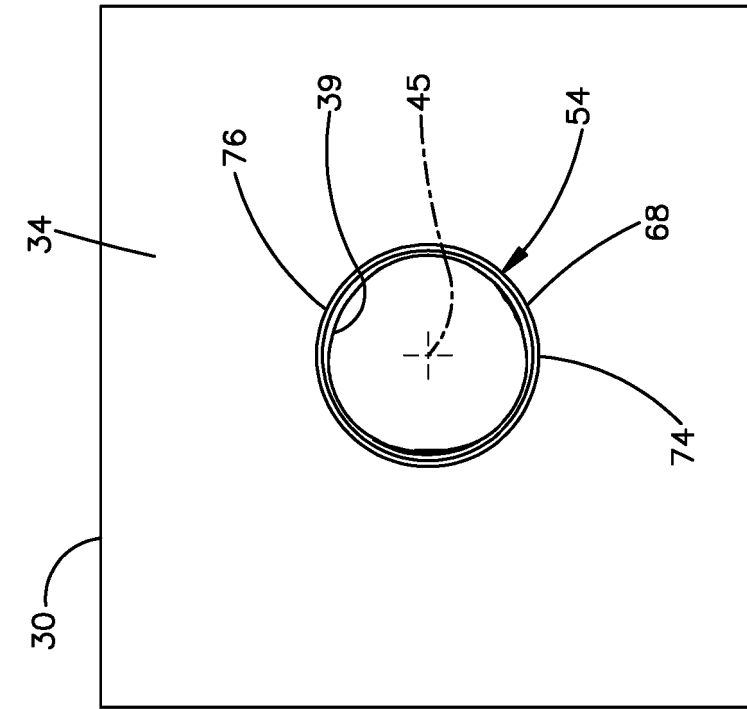


Fig.2C

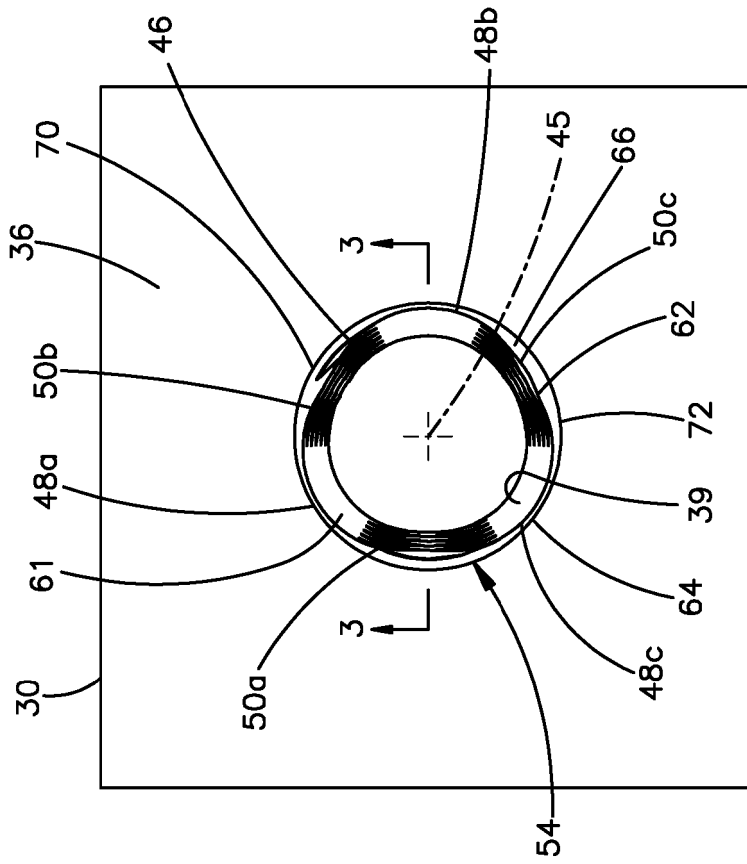
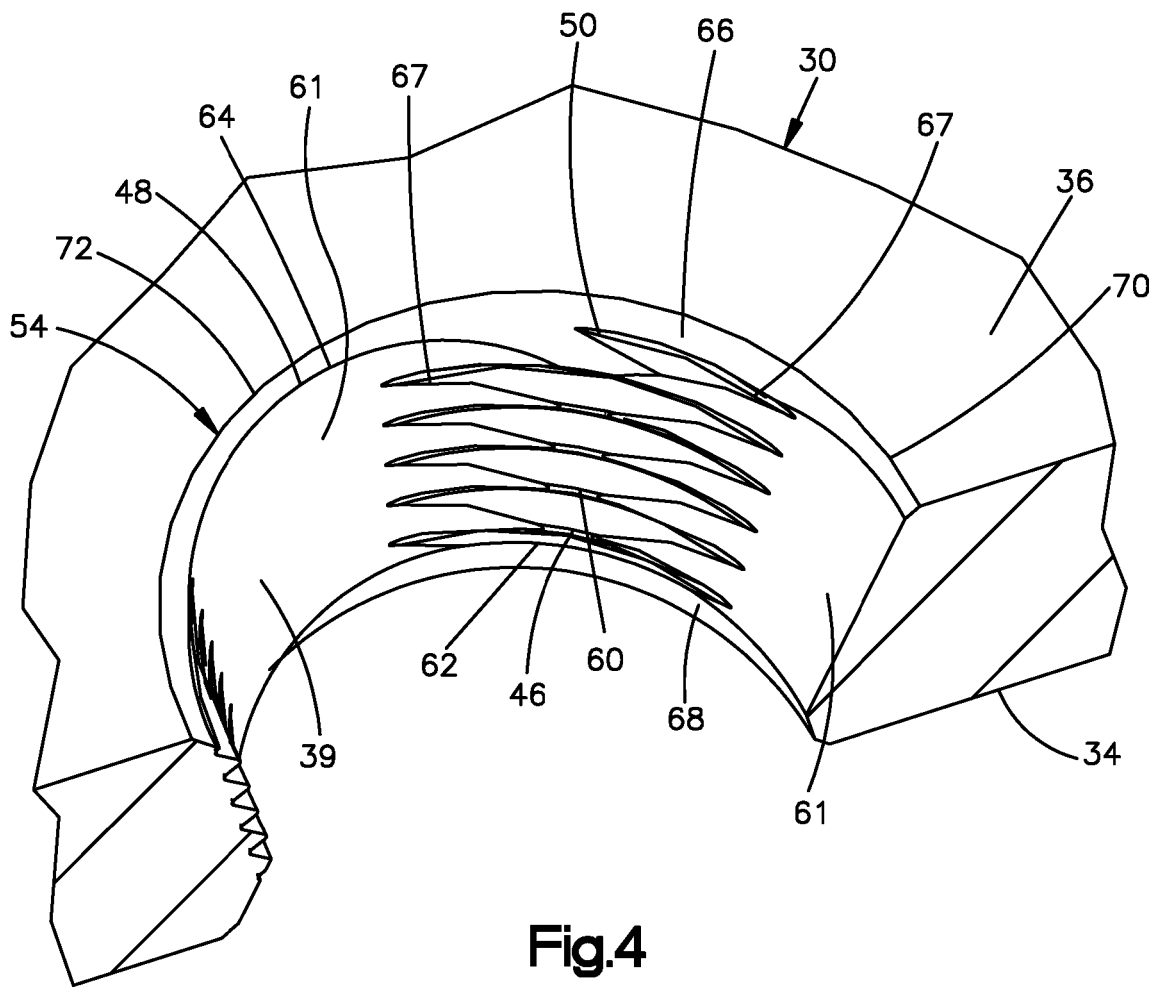
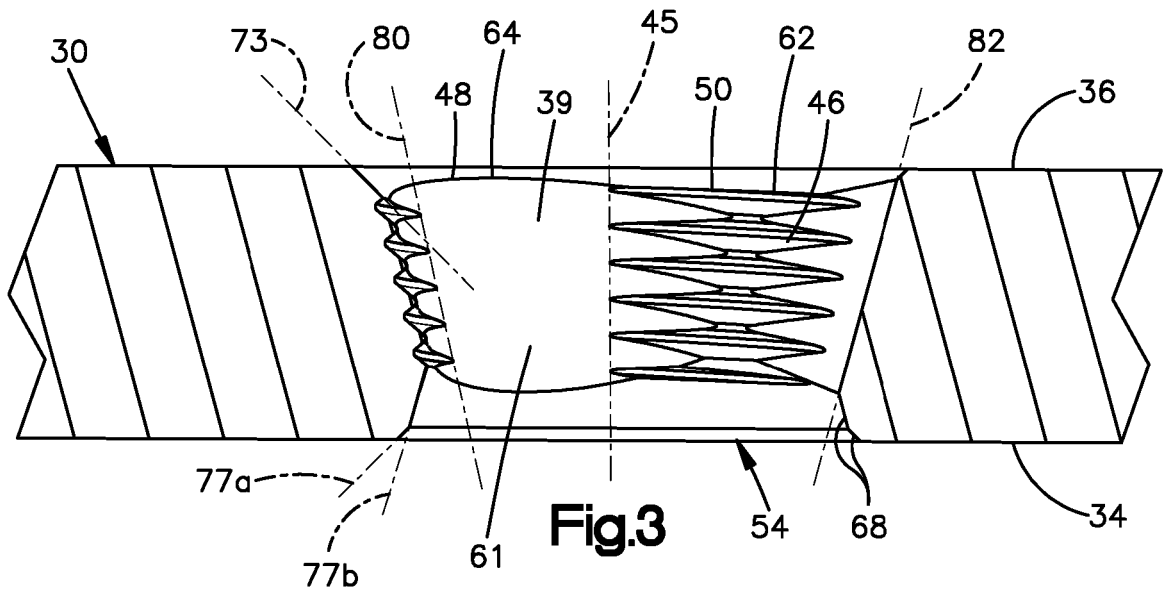
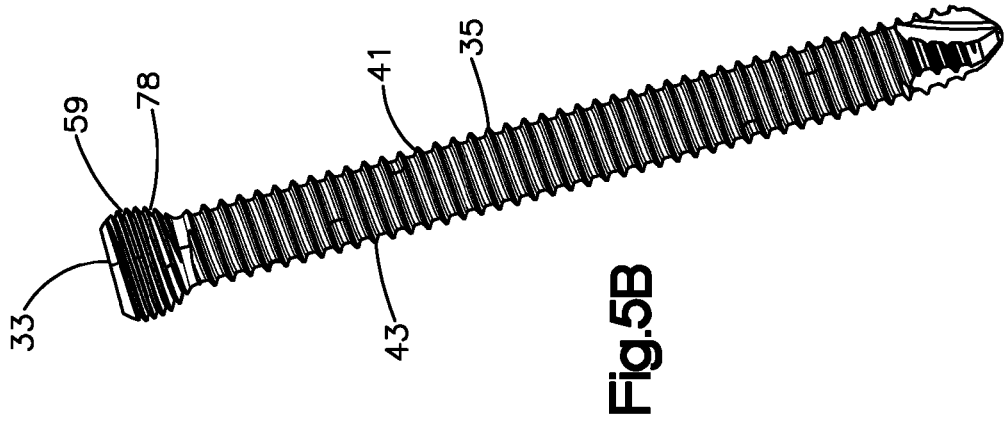
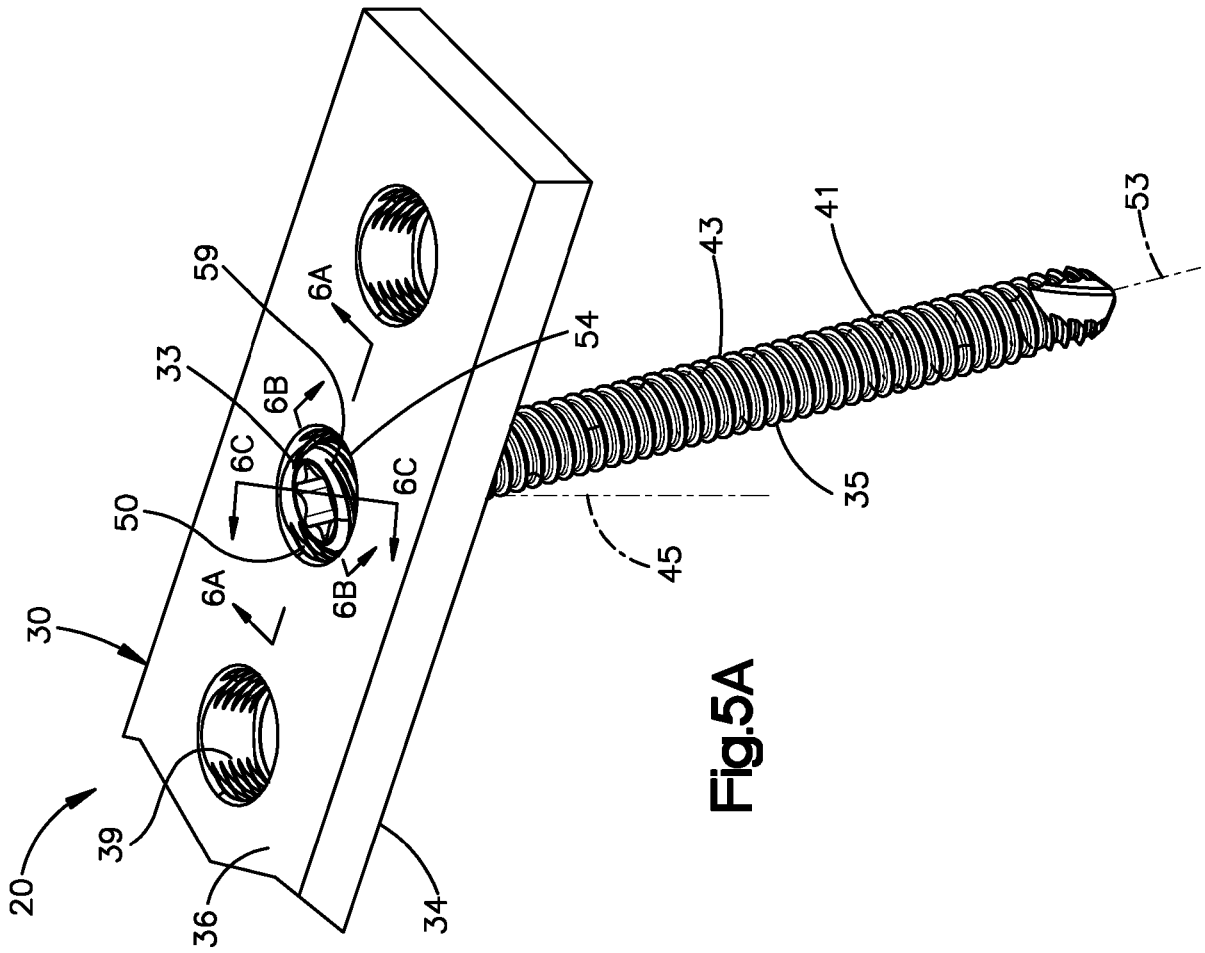
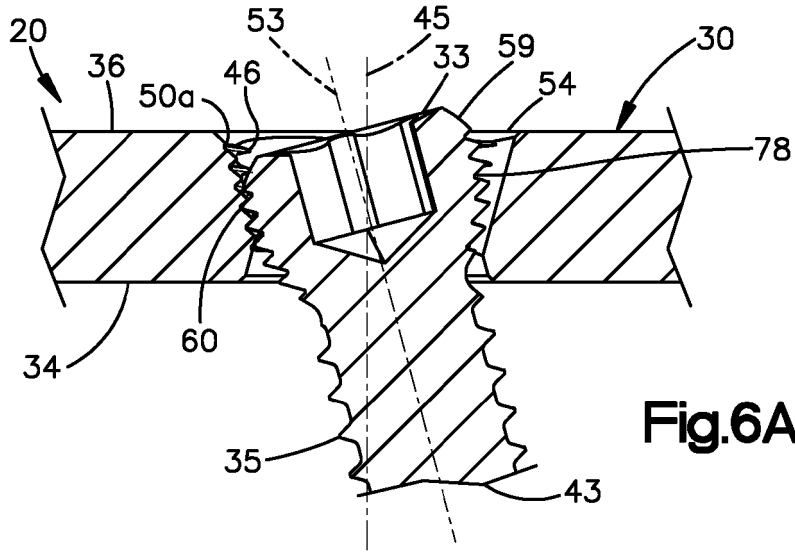


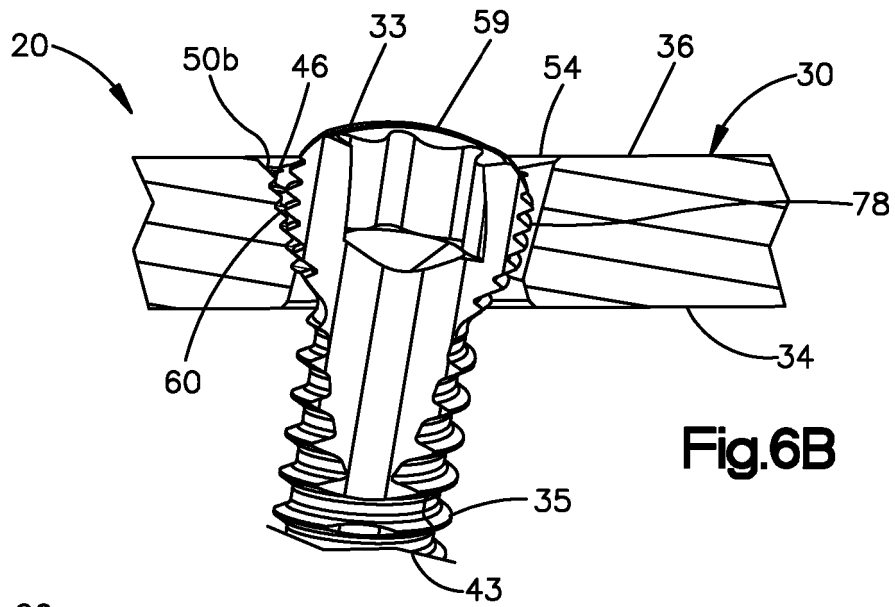
Fig.2D



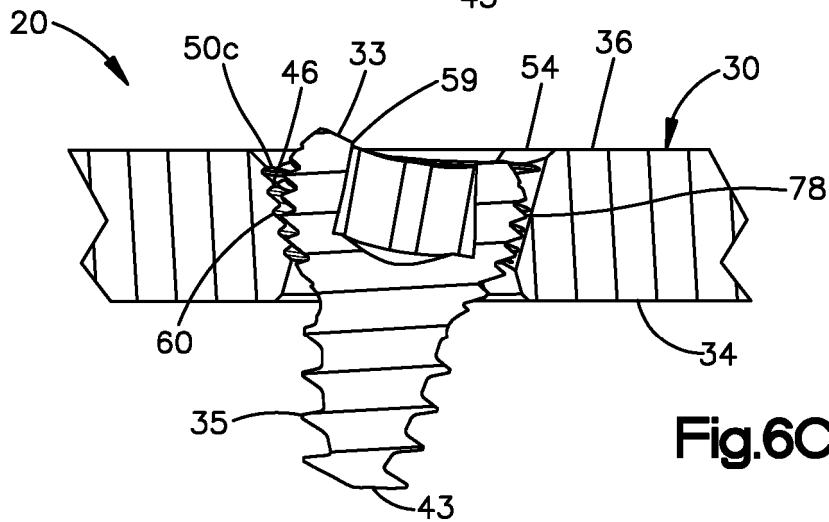




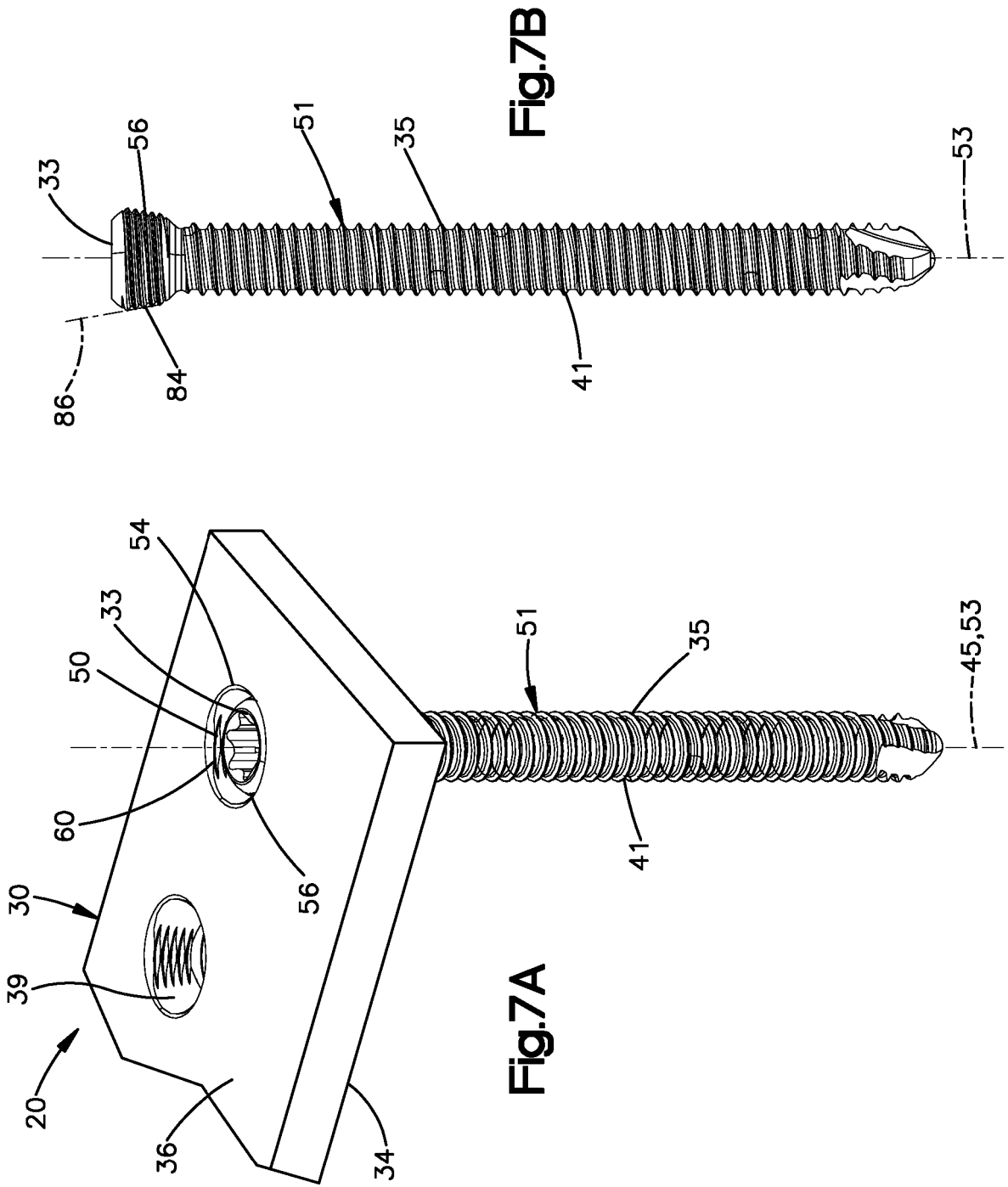
**Fig.6A**



**Fig.6B**



**Fig.6C**



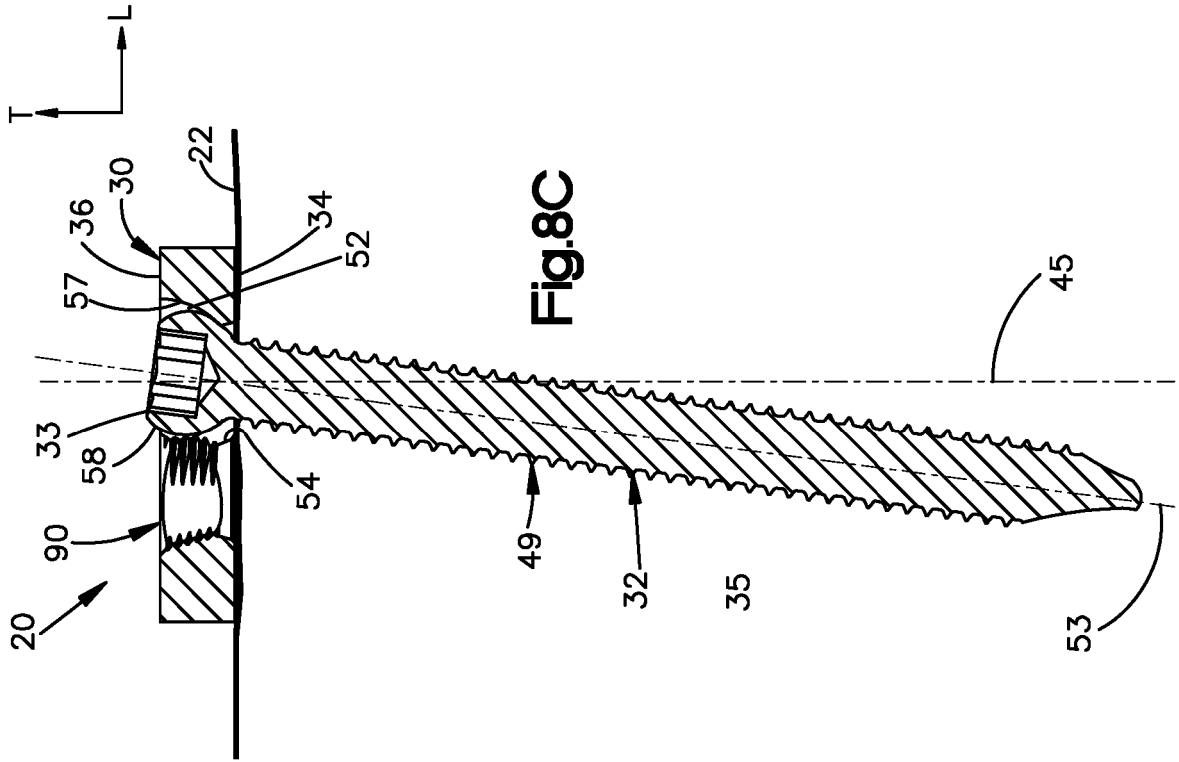


Fig.8C

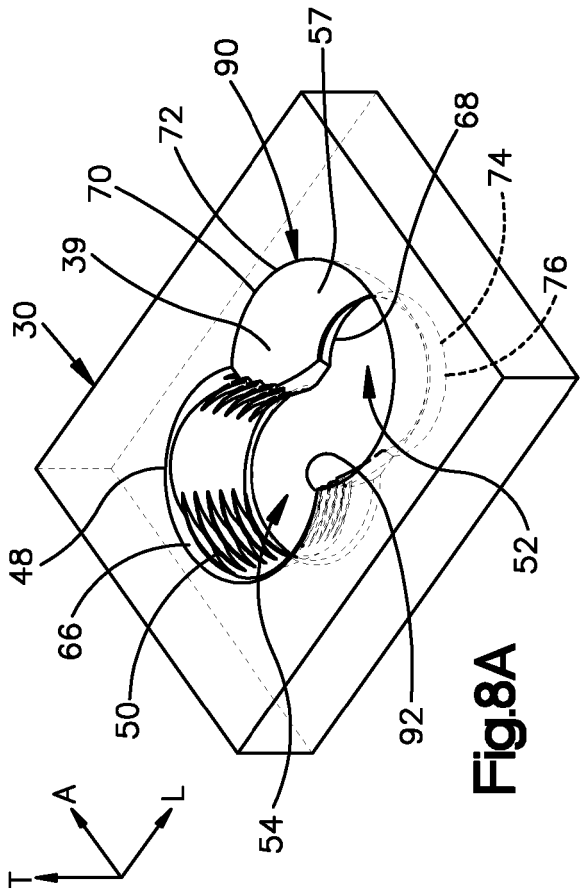


Fig.8A

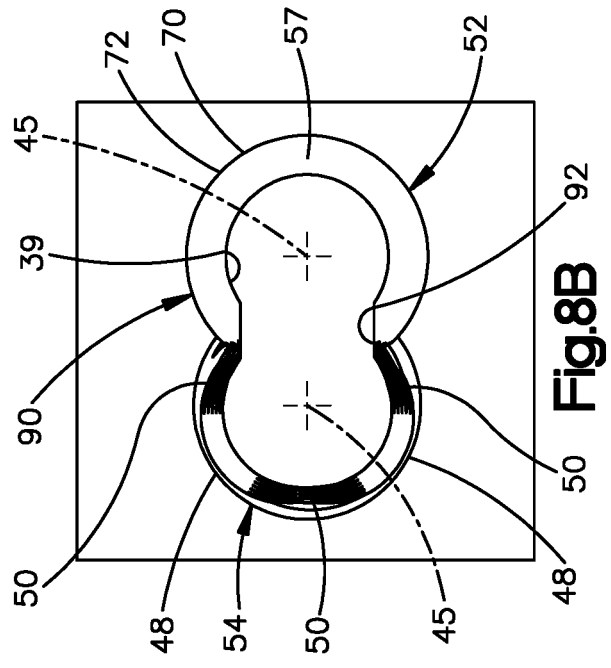


Fig.8B



**REFERENCES CITED IN THE DESCRIPTION**

*This list of references cited by the applicant is for the reader's convenience only. It does not form part of the European patent document. Even though great care has been taken in compiling the references, errors or omissions cannot be excluded and the EPO disclaims all liability in this regard.*

**Patent documents cited in the description**

- US 2018064476 A1 [0003]
- US 2018064477 A1 [0003]
- US 2018064479 A1 [0003]
- DE 102016112845 A1 [0003]
- US 8574268 B [0046]