



(11) **EP 4 177 470 A1**

(12) **EUROPEAN PATENT APPLICATION**
published in accordance with Art. 153(4) EPC

(43) Date of publication:
10.05.2023 Bulletin 2023/19

(21) Application number: **21832290.7**

(22) Date of filing: **25.06.2021**

(51) International Patent Classification (IPC):
F04C 29/06 ^(2006.01) **F04B 39/00** ^(2006.01)
F04C 29/12 ^(2006.01) **F24F 1/12** ^(2011.01)

(52) Cooperative Patent Classification (CPC):
F04B 39/00; F04C 29/06; F04C 29/12; F24F 1/12

(86) International application number:
PCT/JP2021/024166

(87) International publication number:
WO 2022/004597 (06.01.2022 Gazette 2022/01)

(84) Designated Contracting States:
AL AT BE BG CH CY CZ DE DK EE ES FI FR GB GR HR HU IE IS IT LI LT LU LV MC MK MT NL NO PL PT RO RS SE SI SK SM TR
Designated Extension States:
BA ME
Designated Validation States:
KH MA MD TN

(30) Priority: **01.07.2020 JP 2020114403**
01.07.2020 JP 2020114404

(71) Applicant: **Daikin Industries, Ltd.**
Osaka-shi, Osaka 530-0001 (JP)

(72) Inventors:
• **ENDO, Takeshi**
Osaka-shi, Osaka 530-001 (JP)
• **MIZUSHIMA, Yasuo**
Osaka-shi, Osaka 530-001 (JP)
• **MORI, Akira**
Osaka-shi, Osaka 530-001 (JP)

(74) Representative: **Conti, Marco**
Bugnion S.p.A.
Via di Corticella, 87
40128 Bologna (IT)

(54) **HEAT SOURCE UNIT AND SCROLL COMPRESSOR**

(57) A heat source unit (3) of a refrigerant cycle apparatus (1) includes a compressor (10), a pipe, and a fixing member (24) in order to suppress malfunction caused by vibration during operation and excitation during transportation. The compressor (10) has two or three connection portions among a first connection portion (21A) that connects a suction pipe (21), a second connection portion (22A) that connects a discharge pipe (22), and a third connection portion (23A) that connects an injection pipe (23). Each of the pipes includes a vertical portion at least a part of which extends vertically from each of the two or three connection portions. The fixing member (24) fixes two or three of the pipes to each other at the vertical portions. In top view, the connection portions are located on one first straight line (L1). The pipes extending from the connection portions located on the first straight line (L1) are fixed by the fixing member (24).

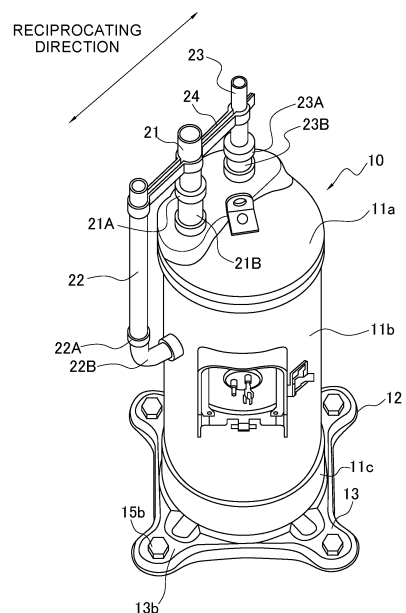

FIG. 3

EP 4 177 470 A1

Description**TECHNICAL FIELD**

[0001] It relates to a heat source unit and a scroll compressor.

BACKGROUND ART

[0002] A heat source unit such as an air conditioner includes a compressor. The compressor sucks a low-pressure gas refrigerant into a compression chamber of the compressor, compresses the low-pressure gas refrigerant into a high-pressure gas refrigerant, and discharges the high-pressure gas refrigerant. Therefore, a suction pipe and a discharge pipe are connected to the compression chamber of the compressor. Some compressors implement a technique called gas injection in order to improve performance of a refrigerant circuit. In the gas injection, a pipe called an injection pipe is connected to the compression chamber of the compressor.

[0003] The suction pipe, the discharge pipe, and the injection pipe often vibrate due to pressure pulsation of a gas refrigerant during operation. Therefore, noise may be generated or excessive stress may be applied. In addition, there is a risk of pipe breakage due to application of excessive force to these pipes by excitation during transportation. These cause a malfunction of devices. An air conditioner depicted in Patent Literature 1 (JP 2011-94914 A) discloses a configuration of suppressing vibration during operation, but does not disclose a configuration of dealing with excitation applied during transportation.

SUMMARY OF THE INVENTION

<Technical Problem>

[0004] There is suppressed a malfunction caused by vibration during operation and excitation during transportation.

<Solution to Problem>

[0005] A heat source unit of a refrigerant cycle apparatus according to a first aspect includes a compressor, pipes, and a fixing member. The compressor has two or three connection portions among a first connection portion, a second connection portion, and a third connection portion. The first connection portion connects a suction pipe. The second connection portion connects a discharge pipe. The third connection portion connects an injection pipe. Each of the pipes has a vertical portion. The vertical portion is a portion at least a part of which extends vertically from each of the two or three connection portions. The fixing member fixes at least two pipes of two or three of the pipes to each other at the vertical portions. In top view, each of the connection portions of

the pipes fixed by the fixing member is located on one first straight line.

[0006] With the above configuration, the heat source unit of the refrigerant cycle apparatus suppresses malfunction caused by vibration of the heat source unit during operation and excitation during transportation.

[0007] A heat source unit of a refrigerant cycle apparatus according to a second aspect is the heat source unit according to the first aspect, in which the compressor further includes a casing and three or four legs provided below the casing. At least one of the legs exists on a second straight line in top view. The second straight line passes through a center of the casing and is orthogonal to the first straight line.

[0008] This configuration contributes to suppression of malfunction of the heat source unit of the refrigerant cycle apparatus.

[0009] A heat source unit of a refrigerant cycle apparatus according to a third aspect is the heat source unit of the refrigerant cycle apparatus according to the second aspect, in which each of the three or four legs is attached with a vibration-proof rubber.

[0010] A heat source unit of a refrigerant cycle apparatus according to a fourth aspect is the heat source unit of the refrigerant cycle apparatus according to the second aspect, in which at least the leg located at a position farthest from the first straight line among the three or four legs is attached with the vibration-proof rubber different in type from the vibration-proof rubber attached to the legs other than the leg located at the position farthest from the first straight line.

[0011] A heat source unit of a refrigerant cycle apparatus according to a fifth aspect is the heat source unit according to any one of the first to fourth aspects, in which the first connection portion, the second connection portion, and the third connection portion are located on the first straight line in top view. The fixing member fixes the suction pipe, the discharge pipe, or the injection pipe to each other.

[0012] A heat source unit of a refrigerant cycle apparatus according to a sixth aspect is the heat source unit according to any one of the first to fifth aspects, in which the injection pipe includes a silencer.

[0013] A heat source unit of a refrigerant cycle apparatus according to a seventh aspect is the heat source unit according to any one of the first to sixth aspects, in which the fixing member is made from metal.

[0014] A compressor according to an eighth aspect includes a casing, two or three connection portions, and three or four legs. Two or three pipes among a suction pipe, a discharge pipe, and an injection pipe are fixed to the casing. The two or three connection portions are two or three connection portions among a first connection portion, a second connection portion, and a third connection portion. The first connection portion connects a suction pipe. The second connection portion connects a discharge pipe. The third connection portion connects an injection pipe. The three or four legs are provided below

the casing. In top view, the connection portions are located on one first straight line. At least one of the legs exists on a second straight line. The second straight line passes through a center of the casing and is orthogonal to the first straight line.

[0015] A scroll compressor according to a ninth aspect includes two or three connection portions among a first connection portion, a second connection portion, and a third connection portion, and a scroll compression mechanism. The first connection portion connects a suction pipe. The second connection portion connects a discharge pipe. The third connection portion connects an injection pipe. The scroll compression mechanism includes a fixed scroll, a movable scroll, and an Oldham coupling. In the scroll compressor, an angle formed between a first direction in which a pipe fixing member extends in top view and a reciprocating direction of the Oldham coupling is 10° or less. The pipe fixing member fixes two or three pipes among the suction pipe, the discharge pipe, and the injection pipe.

[0016] When the scroll compressor is driven, the excitation force in an Oldham motion direction increases due to an influence of an inertial force caused by reciprocating of the Oldham coupling, and rigid body vibration occurs in the scroll compressor and the heat source unit including the scroll compressor, which may impair reliability of the scroll compressor and the heat source unit. Patent Literature 2 (JP H02-485 A) discloses that vibration is transmitted in a predetermined direction by using a balance weight in consideration of the inertial force. However, by adding the balance weight, manufacturing costs of the scroll compressor and the heat source unit increase.

[0017] On the other hand, in the scroll compressor according to the ninth aspect, designing the pipes side by side makes it possible to suppress the vibration of the Oldham coupling in the reciprocating direction without increasing the manufacturing costs.

[0018] A heat source unit of a refrigerant cycle apparatus according to a tenth aspect includes the scroll compressor according to the ninth aspect, a suction pipe, a discharge pipe, an injection pipe, and a pipe fixing member. The suction pipe has a first vertical portion connected to a first connection portion. The discharge pipe has a second vertical portion connected to a second connection portion. The injection pipe has a third vertical portion connected to a third connection portion. The pipe fixing member fixes two or three pipes among the suction pipe, the discharge pipe, and the injection pipe.

[0019] Thus, the vibration in the reciprocating direction of the Oldham coupling is suppressed, and the reliability of the heat source unit is secured.

[0020] A heat source unit of a refrigerant cycle apparatus according to an eleventh aspect is the heat source unit according to the tenth aspect, in which the pipe fixing member fixes the discharge pipe and the injection pipe.

[0021] This configuration contributes to suppression of vibration of the heat source unit.

[0022] A heat source unit of a refrigerant cycle apparatus according to a twelfth aspect is the heat source unit according to the tenth aspect, in which the pipe fixing member fixes the suction pipe and the injection pipe.

5 **[0023]** This configuration contributes to suppression of vibration of the heat source unit.

[0024] A heat source unit of a refrigerant cycle apparatus according to a thirteenth aspect is the heat source unit according to the tenth aspect, in which the pipe fixing member fixes the discharge pipe and the suction pipe.

10 **[0025]** This configuration contributes to suppression of vibration of the heat source unit.

[0026] A heat source unit of a refrigerant cycle apparatus according to a fourteenth aspect is the heat source unit according to the tenth aspect, in which the pipe fixing member fixes the suction pipe, the discharge pipe, and the injection pipe.

15 **[0027]** This configuration contributes to suppression of vibration of the heat source unit.

[0028] A heat source unit of a refrigerant cycle apparatus according to a fifteenth aspect is the heat source unit according to any one of the tenth to fourteenth aspects, in which the pipe fixing member is made from metal.

20 **[0029]** This configuration contributes to ensuring reliability of the heat source unit.

BRIEF DESCRIPTION OF THE DRAWINGS

30 **[0030]**

FIG. 1 is a refrigerant circuit diagram of a refrigerant cycle apparatus.

FIG. 2 is a longitudinal sectional view of a scroll compressor.

FIG. 3 is a schematic view of the scroll compressor.

FIG. 4 is a schematic view of the scroll compressor.

FIG. 5A is a schematic view of a bearing housing.

FIG. 5B is a schematic view of a movable scroll.

FIG. 6A is a schematic view of an Oldham ring.

FIG. 6B is a schematic view of the Oldham ring.

FIG. 7 is a schematic top view of the scroll compressor.

FIG. 8 is a schematic top view of the scroll compressor.

FIG. 9 is a schematic top view of the scroll compressor.

FIG. 10 is a schematic view of the scroll compressor.

DESCRIPTION OF EMBODIMENTS

[0031] Hereinafter, an embodiment of the present invention will be described with reference to the drawings. The following embodiment specifically exemplifies the present invention and is not intended to limit the technical scope of the present invention. (1) Outline of refrigerant cycle apparatus using scroll compressor

[0032] FIG. 1 is a refrigerant circuit diagram of a refrigerant

erant cycle apparatus 1 using a scroll compressor 10 according to one embodiment of the present invention. Examples of the refrigerant cycle apparatus 1 employing the scroll compressor 10 include a "refrigerant cycle apparatus dedicated to cooling operation", a "refrigerant cycle apparatus dedicated to heating operation", and a "refrigerant cycle apparatus switchable to cooling operation or heating operation by using a four-way switching valve". Here, for convenience of description, description will be made with a "refrigerant cycle apparatus dedicated to cooling operation".

[0033] In FIG. 1, the refrigerant cycle apparatus 1 includes a utilization unit 2 and a heat source unit 3, and the utilization unit 2 and the heat source unit 3 are connected to each other by a liquid refrigerant connection pipe 4 and a gas refrigerant connection pipe 5. As illustrated in FIG. 1, the refrigerant cycle apparatus 1 is of a separate type including one utilization unit 2 and one heat source unit 3. However, the present invention is not limited thereto. Alternatively, the refrigerant cycle apparatus 1 may be of a multi-type including a plurality of utilization units 2.

[0034] In the refrigerant cycle apparatus 1, devices such as the scroll compressor 10, an outdoor heat exchanger 6, an economizer heat exchanger 7, an expansion valve 8, and an indoor heat exchanger 9 are connected by pipes to constitute a refrigerant circuit 100.

(1-1) Utilization unit

[0035] The indoor heat exchanger 9 mounted on the utilization unit 2 is a cross-fin type fin-and-tube heat exchanger including a heat transfer tube and a large number of heat transfer fins. The indoor heat exchanger 9 has a liquid side connected to the liquid refrigerant connection pipe 4 and a gas side connected to the gas refrigerant connection pipe 5, and functions as an evaporator for refrigerant.

(1-2) Heat source unit 3

[0036] The heat source unit 3 is equipped with the scroll compressor 10, the outdoor heat exchanger 6, the economizer heat exchanger 7, the expansion valve 8, and the like. The scroll compressor 10 will be described in detail later.

(1-2-1) Outdoor heat exchanger

[0037] The outdoor heat exchanger 6 is a cross-fin type fin-and-tube heat exchanger including a heat transfer tube and a large number of heat transfer fins. One side of the outdoor heat exchanger 6 is connected to a discharge pipe 22 through which the refrigerant discharged from the scroll compressor 10 flows, and the other side of the outdoor heat exchanger 6 is connected to a suction pipe 21. The outdoor heat exchanger 6 functions as a condenser for a gas refrigerant supplied from the scroll

compressor 10 via the discharge pipe 22.

(1-2-2) Economizer heat exchanger

[0038] As shown in FIG. 1, the economizer heat exchanger 7 is disposed between the outdoor heat exchanger 6 and the expansion valve 8. The economizer heat exchanger 7 causes heat exchange between the refrigerant flowing from the outdoor heat exchanger 6 toward the expansion valve 8 and the refrigerant flowing through an injection pipe 23.

(1-2-3) Expansion valve

[0039] The expansion valve 8 is provided on a pipe connecting the outdoor heat exchanger 6 and the liquid refrigerant connection pipe 4. The expansion valve 8 is an electric valve whose opening degree is adjustable for adjusting a pressure and a flow rate of the refrigerant flowing through the pipe. (2) Detailed configuration of scroll compressor

[0040] FIG. 2 is a longitudinal sectional view of the scroll compressor 10 according to one embodiment of the present invention. FIG. 3 is a schematic view showing appearance of the scroll compressor 10. FIG. 4 is a schematic top view of the scroll compressor 10. The scroll compressor 10 according to one embodiment of the present invention is a so-called all-hermetic compressor, is connected to the refrigerant circuit 100 that performs a refrigeration cycle, and sucks and compresses a refrigerant in the refrigerant circuit 100. The scroll compressor 10 is fixed to a bottom plate 12 of the heat source unit 3.

[0041] In the scroll compressor 10, a scroll compression mechanism 50 as a body mechanism, an electric motor 30, a lower bearing member 44, and a drive shaft 40 as a rotary shaft are accommodated in an internal space of a casing 11.

(2-1) Casing, suction pipe, discharge pipe, and injection pipe

[0042] The casing 11 is a sealed container having a vertically long cylindrical shape. In the internal space of the casing 11, the scroll compression mechanism 50, the electric motor 30, and the lower bearing member 44 are disposed in order from top to bottom. The drive shaft 40 is disposed such that its axial direction is along a height direction of the casing 11. A detailed structure of the scroll compression mechanism 50 will be described later.

[0043] As illustrated in FIG. 3, the suction pipe 21, the discharge pipe 22, and the injection pipe 23 are attached to the casing 11 as pipes. The suction pipe 21 is connected via a first connection portion 21A to a first vertical portion 21B which is a vertically extending portion of the suction pipe 21. A part of the first vertical portion 21B is welded and fixed to an upper lid 11a of the casing 11. A lower end of the first vertical portion 21B is connected to a fixed scroll 60 of the scroll compression mechanism

50. The suction pipe 21 communicates with a compression chamber Sc of the scroll compression mechanism 50 via the first vertical portion 21B. A low-pressure refrigerant in the refrigeration cycle before being compressed by the scroll compressor 10 flows through the suction pipe 21 and the first vertical portion 21B.

[0044] The discharge pipe 22 is connected via a second connection portion 22A to a second vertical portion 22B which is a vertically extending portion of the discharge pipe 22. A part of the second vertical portion 22B is welded and fixed to a cylindrical member 11b of the casing 11. The second vertical portion 22B is disposed so that an end of the second vertical portion 22B inside the casing 11 protrudes into a high-pressure space S1 formed below a bearing housing 51 of the scroll compression mechanism 50. A high-pressure refrigerant in the refrigeration cycle after being compressed by the scroll compression mechanism 50 flows through the discharge pipe 22 and the second vertical portion 22B.

[0045] The injection pipe 23 is connected via a third connection portion 23A to a third vertical portion 23B which is a vertically extending portion of the injection pipe 23. A part of the third vertical portion 23B is welded and fixed to the upper lid 11a of the casing 11. An end of the third vertical portion 23B inside the casing 11 is connected to the fixed scroll 60, and the third vertical portion 23B supplies the refrigerant to an injection passage formed in the fixed scroll 60. The injection passage communicates with the compression chamber Sc of the scroll compression mechanism 50, and the refrigerant supplied from the third vertical portion 23B is supplied to the compression chamber Sc as a pressure in a middle (intermediate pressure) between a low pressure and a high pressure in the refrigeration cycle.

[0046] In the scroll compressor 10 according to the present embodiment, as illustrated in FIGS. 2 and 3, the first vertical portion 21B, the second vertical portion 22B, and the third vertical portion 23B include a coupling pipe fixed to the casing 11 and pipes inside and outside the casing 11 inserted into the coupling pipe.

[0047] As illustrated in FIG. 4, in top view, the connection portions 21A, 22A, and 23A of the pipes 21, 22, and 23 are disposed so as to be located on one first straight line L1. The pipes 21, 22, and 23 extending from the connection portions 21A, 22A, and 23A located on the first straight line L1 have the vertical portions 21B, 22B, and 23B fixed by a fixing member 24.

[0048] Specifically, as illustrated in FIG. 4, in a top view of an end connecting the connection portions 21A, 22A, and 23A and the pipes 21, 22, and 23, the first straight line L1 is preferably a substantially straight line that connects centers of the connection portions. However, the first straight line L1 may be slightly bent as long as rigid body vibration of the scroll compressor 10 can be suppressed. The pipes 21, 22, and 23 are disposed so that an angle formed by the first straight line L1 and a reciprocating direction of an Oldham coupling 80 described later is 10° or less. The angle may be slightly shifted as

long as the pipes 21, 22, and 23 can suppress rigid body vibration of the scroll compressor 10.

[0049] The pipe fixing member 24 fixes parts of the pipes 21, 22, and 23 vertically extending from the connection portions 21A, 22A, and 23A to each other. The pipe fixing member 24 may be, for example, a metal such as iron, and may be, for example, a sheet-metal member formed to surround each of the pipes 21, 22, and 23 in a circumferential direction as illustrated in FIG. 3. The pipe fixing member 24 may include a vibration reducing member for reducing vibration between the pipe fixing member 24 and each of the pipes 21, 22, and 23. This structure can reduce vibration applied to the scroll compression mechanism 50. Details will be described later.

(2-2) Support bracket and vibration-proof rubber

[0050] A support bracket 13 for fixing the casing 11 to the bottom plate 12 of an outdoor unit is provided below the casing 11. The support bracket 13 includes an attachment portion 13a attached to a bottom of the casing 11 to support the casing 11 from below, and a support leg (leg) 13b fixed to the bottom plate 12 via a vibration-proof rubber 14. The attachment portion 13a and the support leg 13b are formed integrally. Four support legs 13b are provided apart from each another in a circumferential direction of the casing 11.

[0051] A part of the bottom plate 12 protrudes upward, and the vibration-proof rubber 14 is installed on the protrusion of the bottom plate 12. The vibration-proof rubber 14 includes a cylindrical rubber material extending in an up-down direction. A fastening nut 15a is welded to the bottom plate 12.

[0052] By inserting the fastening bolt 15b from above the support bracket 13 and fastening the fastening bolt 15b to the fastening nut 15a, the casing 11 is fixed to the bottom plate 12 in a state where the vibration-proof rubber 14 is sandwiched between each of the support legs 13b of the casing 11 and the bottom plate 12.

[0053] At least one (here, vibration-proof rubbers 14a and 14b) of the four vibration-proof rubbers 14 respectively attached to the support legs 13b is attached so as to exist on a second straight line L2 that passes through a center of the cylindrical member 11b of the casing 11, is orthogonal to the first straight line L1 connecting the pipes 21, 22, and 23 as illustrated in FIG. 4. Here, orthogonal means that the second straight line L2 is preferably at an angle of $90^\circ \pm 5^\circ$ with respect to the first straight line L1. The angle may be slightly shifted as long as the rigid body vibration of the scroll compressor 10 can be suppressed. One vibration-proof rubber 14a of the vibration-proof rubbers 14a and 14b is located at a position farthest from the first straight line L1 than the other three vibration-proof rubbers 14b, 14c, and 14d, and can efficiently reduce vibration applied to the scroll compression mechanism 50. Therefore, the vibration-proof rubber 14a is preferably include a material having a higher spring constant than the other three vibration-

proof rubbers 14b, 14c, and 14d.

(2-3) Electric motor

[0054] The electric motor 30 includes a stator 31 and a rotor 32. The stator 31 is fixed to the casing 11. The rotor 32 is disposed coaxially with the stator 31. Into the rotor 31, a main shaft 41 of the drive shaft 40 is inserted.

(2-4) Drive shaft

[0055] The drive shaft 40 is provided with the main shaft 41 and an eccentric portion 42. A lower part of the main shaft 41 penetrates the rotor 32 of the electric motor 30. The eccentric portion 42 has a columnar shape with a diameter smaller than the main shaft 41, and protrudes from an upper end surface of the main shaft 41. The eccentric portion 42 has an axis that is eccentric relative to an axis of the main shaft 41.

[0056] An oil supply passage 43 penetrating in the up-down direction is formed in the drive shaft 40. A refrigerating machine oil as a lubricating oil is stored at the bottom of the casing 11. When the drive shaft 40 rotates, the refrigerating machine oil stored at the bottom of the casing 11 is sucked up to the oil supply passage 43 and supplied to a sliding portion of the lower bearing member 44 and the scroll compression mechanism 50.

(2-5) Scroll compression mechanism

[0057] The scroll compression mechanism 50 includes the bearing housing 51, the fixed scroll 60, a movable scroll 70, and the Oldham coupling 80. In the scroll compression mechanism 50, the compression chamber Sc as a fluid chamber is formed by the fixed scroll 60 and the movable scroll 70. The Oldham coupling 80 is a member to restrict rotation of the movable scroll 70.

(2-5-1) Bearing housing

[0058] The bearing housing 51 has a thick disc shape, and has an outer peripheral edge fixed to the casing 11. A central recess 52 and an annular projection 53 are formed at a center of the bearing housing 51. The central recess 52 is a circular pit that opens to an upper surface of the bearing housing 51. The annular projection 53 is formed along an outer periphery of the central recess 52 and protrudes from the upper surface of the bearing housing 51. An end surface of the annular projection 53 is a flat surface.

[0059] On the bearing housing 51, a central protrusion 54 is formed. The central protrusion 54 is located below the central recess 52 and protrudes downward. A through hole penetrating the central protrusion 54 in the up-down direction is formed in the central protrusion 54, and the main shaft 41 of the drive shaft 40 is inserted through the through hole to rotatably support the drive shaft 40.

[0060] A part of the upper surface of the bearing hous-

ing 51 outside the annular projection 53 is a flat surface 55. As illustrated in FIG. 5A, the bearing housing 51 is provided with two fixed-side key grooves 56 that open to the flat surface 55.

[0061] The fixed-side key grooves 56 are elongated grooves extending along a straight line orthogonal to a center axis of the main shaft 41 of the drive shaft 40. The two fixed-side key grooves 56 are located opposite to each other across the center axis of the main shaft 41 of the drive shaft 40. Fixed-side keys 82 of the Oldham coupling 80 are engaged with the fixed-side key grooves 56.

[0062] As illustrated in FIG. 2, the fixed scroll 60 and the movable scroll 70 are placed on the bearing housing 51. The fixed scroll 60 is fixed to the bearing housing 51 with a bolt or the like. On the other hand, the movable scroll 70 is driven by the drive shaft 40 to revolve.

(2-5-2) Fixed scroll

[0063] The fixed scroll 60 is a member in which a fixed-side end plate 61 and a fixed-side lap 62 are integrally formed. The fixed-side end plate 61 has a disc shape. The fixed-side lap 62 has a spiral wall shape and is provided on a lower surface of the fixed-side end plate 61.

The fixed scroll 60 is a member in which a fixed scroll substrate 61 and a fixed-side lap 62 extending downward in a spiral shape from the lower surface of the fixed scroll substrate 61 are integrally formed.

[0064] In the fixed-side end plate 61, a discharge port 61a is formed. The discharge port 61a is a through hole formed near a center of the fixed-side end plate 61, and penetrates the fixed-side end plate 61 in a thickness direction. The first vertical portion 21B is inserted near an outer periphery of the fixed-side end plate 61.

(2-5-3) Movable scroll

[0065] The movable scroll 70 illustrated in FIG. 5B is a member in which a movable-side end plate 71 and a movable-side lap 72 are integrally formed. The movable-side end plate 71 has a disc shape. The movable-side lap 72 has a spiral wall shape and protrudes from an upper surface of the movable-side end plate 71.

[0066] In the movable scroll 70, two movable-side key grooves 73 that open to a lower surface of the movable-side end plate 71 are formed. Movable-side keys 81 of the Oldham coupling 80 are engaged with the movable-side key grooves 73.

[0067] In the scroll compression mechanism 50, the fixed scroll 60 and the movable scroll 70 are disposed so that the lower surface of the fixed-side end plate 61 and the upper surface of the movable-side end plate 71 face each other, and the fixed-side lap 62 and the movable-side lap 72 mesh with each other. In the scroll compression mechanism 50, the fixed-side lap 62 and the movable-side lap 72 mesh with each other to form a plurality of compression chambers Sc.

(2-5-4) Oldham coupling

[0068] As illustrated in FIGS. 6A and 6B, the Oldham coupling 80 includes one ring 83, two movable-side keys 81, and two fixed-side keys 82. The ring 83 has a rectangular cross section. The ring portion 83 has a thickness that is constant over an entire circumference of the ring 83. The ring 83 has an upper surface and a lower surface that are flat surfaces parallel to each other. The movable-side keys 81 are located above the upper surface of the ring 83. The fixed-side keys 82 are located below the lower surface of the ring 83. Here, the two movable-side keys 81 and the two fixed-side keys 82 are arranged at substantially equally spaced apart from each another in a circumferential direction, but there are numerous variations in the number and arrangement of the keys. Here, the two movable side keys 81 are disposed on opposite to each other across a center of the ring 83. The two fixed-side keys 82 are disposed on opposite to each other across the center of the ring 83.

[0069] As illustrated in FIG. 2, the Oldham coupling 80 is disposed between the movable-side end plate 71 of the movable scroll 70 and the bearing housing 51. In the scroll compression mechanism 50 in operation, the movable-side keys 81 of the Oldham coupling 80 are in sliding contact with inner surfaces of the movable-side key grooves 73 of the movable scroll 70. The fixed-side keys 82 of the Oldham coupling 80 are in sliding contact with inner surfaces of the fixed-side key grooves 56 of the bearing housing 51. Therefore, the Oldham coupling 80 serves to allow the movable scroll 70 to revolve with respect to the bearing housing 51 and prevent the movable scroll 70 from rotating with respect to the bearing housing 51. In other words, the Oldham coupling 80 slides on both the bearing housing 51 and the movable scroll 70, and thus the movable scroll 70 revolves without rotating with respect to the fixed scroll 60 fixed to the bearing housing 51.

(3) Operation and motion

[0070] Hereinafter, operation and motion of the scroll compressor 10 will be described. In the scroll compressor 10, when the movable scroll 70 revolves, a low-pressure gas refrigerant flowing into the scroll compression mechanism 50 through the suction pipe 21 is sucked into the compression chamber Sc from around the outer peripheral ends of the fixed-side lap 62 and the movable-side lap 72. When the movable scroll 70 further moves, the compression chamber Sc is blocked from the suction pipe 21 to be in a closed state, and thereafter, the compression chamber Sc moves along the fixed-side lap 62 and the movable-side lap 72 toward inner peripheral ends of the fixed-side lap 62 and the movable-side lap 72. In this process, a volume of the compression chamber Sc gradually decreases, and the gas refrigerant in the compression chamber Sc is compressed.

[0071] When the volume of the compression chamber

Sc gradually decreases as the movable scroll 70 moves, the compression chamber Sc eventually communicates with the discharge port 61a. The refrigerant compressed in the compression chamber Sc (that is, a high-pressure gas refrigerant) flows into a discharge gas passage through the discharge port 61a, and is then discharged to a portion between the scroll compression mechanism 50 and the electric motor 30 in the internal space of the casing 11. The high-pressure gas refrigerant discharged into the internal space of the casing 11 flows out of the casing 11 through the discharge pipe 22.

[0072] A refrigerating machine oil as a lubricating oil is stored in the internal space of the casing 11. The pressure of the refrigerating machine oil stored in the casing 11 is substantially equal to a pressure of the gas refrigerant discharged from the scroll compression mechanism 50. While the scroll compressor 10 is operating, the drive shaft 40 rotates, the refrigerating machine oil stored at the bottom of the casing 11 is sucked up to the oil supply passage 43 and supplied to the sliding portion of the lower bearing member 44 and the scroll compression mechanism 50.

(4) Characteristics

[0073] (4-1)

The heat source unit 3 of the refrigerant cycle apparatus 1 of the present invention includes the compressor 10, pipes, and the fixing member 24. The compressor 10 has two or three connection portions among the first connection portion 21A, the second connection portion 22B, and the third connection portion 23A. The compressor 10 includes the casing 11 and three or four legs 13b provided below the casing 11. The vibration-proof rubber 14 is attached to each of the three or four legs 13b. The first connection portion 21A connects the suction pipe 21. The second connection portion 22A connects the discharge pipe 22. The third connection portion 23A connects the injection pipe 23. Each of the pipes has a vertical portion. The vertical portion is a portion at least a part of which extends vertically from each of the two or three connection portions. The vertical portion extending from the first connection portion 21A is the first vertical portion 21B. The vertical portion extending from the second connection portion 22A is the second vertical portion 22B. The vertical portion extending from the third connection portion 23A is the third vertical portion 23B. The fixing member 23 fixes at least two of the two or three pipes to each other at the vertical portions. The fixing member 23 includes a metal. In top view, each of the connection portions of the pipes fixed by the fixing member 23 is located on one first straight line L1. At least one leg 13b exists on the second straight line L2 passing through the center of the casing 11 and orthogonal to the first straight line L1 in top view.

[0074] In the compressor 10 of the heat source unit 3, when the electric motor 30 is energized, the drive shaft 40 drives the movable scroll 70. The movable scroll 70

is restricted from rotating by the Oldham coupling 80 and does not rotate but revolves.

[0075] At this time, in the Oldham coupling 80, the fixed-side keys 82 reciprocate in the arrow direction in FIG. 6A along the fixed-side key grooves 56. Then, due to an influence of an inertial force due to the reciprocating motion of the Oldham coupling 80, an excitation force in a reciprocating direction of the Oldham coupling 80 increases. Therefore, vibration due to an unbalanced inertial force of the Oldham coupling 80 is transmitted to the casing 11, and the rigid body vibration of the scroll compressor 10 increases.

[0076] In the present embodiment, by fixing the pipes 21, 22, and 23 to each other by the same pipe fixing member in a state of being disposed along the first straight line, it is possible to increase support rigidity in the reciprocating direction of the Oldham coupling 80 and to suppress the rigid body vibration of the scroll compressor 10 effectively. As a result, stress applied to each pipe due to vibration can be suppressed, a risk of pipe breakage or the like can be reduced, and reliability of the scroll compressor 10 can be enhanced. In addition, this configuration is intended to reduce the risk without increasing a production cost of the scroll compressor 10.

[0077] (4-2)

The scroll compressor 10 of the present invention includes two or three connection portions among the first connection portion 21A, the second connection portion 22A, and the third connection portion 23A, and the scroll compression mechanism 50. The first connection portion 21A connects the suction pipe 21. The second connection portion 22A connects the discharge pipe 22. The third connection portion 23A connects the injection pipe 23. The scroll compression mechanism 50 includes the fixed scroll 60, the movable scroll 70, and the Oldham coupling 80. The fixing member 24 fixes two or three pipes among the suction pipe 21, the discharge pipe 22, and the injection pipe 23. In the scroll compressor 10, an angle formed between a first direction in which the pipe fixing member 24 extends in top view and the reciprocating direction of the Oldham coupling 80 is 10° or less.

[0078] In the scroll compressor 10, when the electric motor 30 is energized, the drive shaft 40 drives the movable scroll 70. The movable scroll 70 is restricted from rotating by the Oldham coupling 80 and does not rotate but revolves.

[0079] At this time, in the Oldham coupling 80, the fixed-side keys 82 reciprocate in the arrow direction in FIG. 6A along the fixed-side key grooves 56. Then, due to an influence of an inertial force due to the reciprocating motion of the Oldham coupling 80, an excitation force in a reciprocating direction of the Oldham coupling 80 increases. Therefore, vibration due to an unbalanced inertial force of the Oldham coupling 80 is transmitted to the casing 11, and the rigid body vibration of the scroll compressor 10 increases.

[0080] In the present embodiment, by fixing the pipes 21, 22, and 23 to each other by the same pipe fixing

member in a state of being disposed along the first straight line, it is possible to increase support rigidity in the reciprocating direction of the Oldham coupling 80 and to suppress the rigid body vibration of the scroll compressor 10 effectively. As a result, stress applied to each pipe due to vibration can be suppressed, a risk of pipe breakage or the like can be reduced, and reliability of the scroll compressor 10 can be enhanced. In addition, this configuration is intended to reduce the risk without increasing a production cost of the scroll compressor 10.

[0081] (4-3)

The heat source unit 3 of the refrigerant cycle apparatus 1 of the present invention includes the scroll compressor 10 configured as described above, the suction pipe 21, the discharge pipe 22, the injection pipe 23, and the pipe fixing member 24. The suction pipe 21 has the first vertical portion 21B connected to the first connection portion 21A. The discharge pipe 22 has the second vertical portion 22B connected to the second connection portion 22A. The injection pipe 23 has the third vertical portion 23B connected to the third connection portion 23A. The pipe fixing member 24 fixes two or three pipes among the suction pipe 21, the discharge pipe 22, and the injection pipe 23. In the present embodiment, the pipe fixing member 24 fixes the suction pipe 21, the discharge pipe 22, and the injection pipe 23. The pipe fixing member 24 is metal.

[0082] The heat source unit 3 configured as described above can effectively suppress rigid body vibration of the scroll compressor 10 and improve reliability of the scroll compressor 10. In addition, the pipe fixing member 24 can more effectively suppress the rigid body vibration by preferably fixing the three pipes among the suction pipe 21, the discharge pipe 22, and the injection pipe 23. By using a metal member having high strength as the pipe fixing member 24, deformation or the like of the pipe fixing member 24 can be suppressed, and the reliability of the heat source unit 3 can be further enhanced.

(5) Modifications

(5-1) Modification 1

[0083] In the present invention, the pipe fixing member 24 fixes the suction pipe 21, the discharge pipe 22, and the injection pipe 23 extending vertically from the connection portions 21A, 22A, and 23A to each other. As a result, it is preferable to suppress vibration due to the unbalanced inertial force of the Oldham coupling 80. However, two of the three pipes 21, 22, or 23 may be fixed to each other by the pipe fixing member 24 as long as vibration of the scroll compressor 10 can be suppressed. Specifically, the pipe fixing member 24 may fix the discharge pipe 22 and the injection pipe 23 to each other as illustrated in FIG. 7, may fix the suction pipe 21 and the injection pipe 23 to each other as illustrated in FIG. 8, or may fix the discharge pipe 22 and the suction pipe 21 to each other as illustrated in FIG. 9.

[0084] Since the angle formed by the first straight line L1 in which the pipe fixing member 24 fixing two of the three pipes 21, 22, or 23 to each other extends in top view and the reciprocating direction of the Oldham coupling 80 is 10° or less, the vibration of the scroll compressor 10 can be suppressed. Note that the angle may be slightly shifted as long as the vibration of the scroll compressor 10 can be suppressed.

(5-2) Modification 2

[0085] In the present invention, the scroll compressor 10 includes the three pipes 21, 22, and 23 of the suction pipe 21, the discharge pipe 22, and the injection pipe 23. However, the invention described in the present invention can also be applied to the scroll compressor 10 not including the injection pipe 23.

[0086] Specifically, the scroll compressor 10 includes the suction pipe 21 and the discharge pipe 22, and the pipe fixing member 24 fixes the discharge pipe 22 and the suction pipe 21 to each other. This configured can effectively suppress the rigid body vibration of the scroll compressor 10 and improve the reliability of the scroll compressor 10.

(5-3) Modification 3

[0087] In the present invention, the scroll compressor 10 includes four support legs (legs) 13b. However, the invention described in the present invention can also be applied to the scroll compressor 10 including three support legs 13b.

[0088] Specifically, in the scroll compressor 10 including the three support legs 13b illustrated in FIG. 10, the support bracket 13 for fixing the casing 11 to the bottom plate 12 of the outdoor unit is provided below the casing 11. The support bracket 13 includes the support legs (legs) 13b each fixed to the bottom plate 12 via a vibration-proof member 14. Three support legs 13b are provided apart from each another in the circumferential direction of the casing 11.

[0089] The vibration-proof member 14 includes a cylindrical rubber material extending in the up-down direction. One of the three vibration-proof members 14 respectively attached to the support legs 13b is attached so as to exist on the second straight line L2 that passes through the center of the cylindrical member 11b of the casing 11, is orthogonal to the first straight line L1 which connects the pipes 21, 22, and 23. Here, orthogonal means that the second straight line L2 is preferably at an angle of $90^\circ \pm 5^\circ$ with respect to the first straight line L1. The angle may be slightly shifted as long as the rigid body vibration of the scroll compressor 10 can be suppressed.

(5-4) Modification 4

[0090] In the present invention, the injection pipe 23

may include a silencer. Accordingly, noise generated in the heat source unit 3 can be suppressed.

[0091] (6) The embodiment of the present invention has been described above. It will be understood that various changes to modes and details can be made without departing from the spirit and scope of the present invention recited in the claims.

REFERENCE SIGNS LIST

[0092]

1	Refrigerant cycle apparatus
3	Heat source unit
10	Scroll compressor
11	Casing
13b	Leg
14	Vibration-proof rubber
21	Suction pipe
21A	First connection portion
21B	First vertical portion
22	Discharge pipe
22A	Second connection portion
22B	Second vertical portion
23	Injection pipe
23A	Third connection portion
23B	Third vertical portion
24	Pipe fixing member
50	Scroll compression mechanism
60	Fixed scroll
70	Movable scroll
80	Oldham coupling
L1	First straight line
L2	Second straight line

CITATION LIST

PATENT LITERATURE

[0093]

Patent Literature 1: JP 2011-94914 A

Patent Literature 2: JP Patent Application H02-485

Claims

1. A heat source unit (3) of a refrigerant cycle apparatus (1), the heat source unit (3) comprising:

a compressor (10) including two or three connection portions among a first connection portion (21A) connecting a suction pipe (21), a second connection portion (22A) connecting a discharge pipe (22), and a third connection portion (23A) connecting an injection pipe (23);
a pipe including a vertical portion at least a part

- of which extends vertically from each of the two or three connection portions; and a fixing member (24) that fixes at least two of the vertical portions of two or three of the pipes, wherein
 5 each of the connection portions of the pipes fixed by the fixing member is located on one first straight line (L1) in top view.
2. The heat source unit (3) of the refrigerant cycle apparatus (1) according to claim 1, wherein
 10 the compressor (10) further includes a casing (11) and three or four legs (13b) provided below the casing (11), and
 15 at least one of the legs (13b) exists on a second straight line (L2) that passes through a center of the casing (11) and is orthogonal to the first straight line (L1) in top view.
3. The heat source unit (3) of the refrigerant cycle apparatus (1) according to claim 2, wherein each of the three or four legs (13b) is attached with a vibration-proof rubber (14).
 20
4. The heat source unit (3) of the refrigerant cycle apparatus (1) according to claim 2, wherein
 25 at least the leg (13b) located at a position farthest from the first straight line (L1) among the three or four legs (13b) is attached with the vibration-proof rubber (14) different in type from the vibration-proof rubber attached to the legs (13b) other than the leg (13b) located at the position farthest from the first straight line (L1).
 30
5. The heat source unit (3) of the refrigerant cycle apparatus (1) according to any one of claims 1 to 4, wherein
 35 the first connection portion (21A), the second connection portion (22A), and the third connection portion (23A) are located on the first straight line (L1) in top view, and
 40 the fixing member (24) fixes the suction pipe (21), the discharge pipe (22), and the injection pipe (23) to each other.
 45
6. The heat source unit (3) of the refrigerant cycle apparatus (1) according to any one of claims 1 to 5, wherein
 50 the injection pipe (23) includes a silencer.
7. The heat source unit (3) of the refrigerant cycle apparatus (1) according to any one of claims 1 to 6, wherein
 55 the fixing member (24) is made from metal.
8. A compressor comprising:
 a casing (11) to which two or three pipes among a suction pipe (21), a discharge pipe (22), and an injection pipe (23) are fixed;
 two or three connection portions among a first connection portion (21A) connecting the suction pipe (21), a second connection portion (22A) connecting the discharge pipe (22), and a third connection portion (23A) connecting the injection pipe (23); and
 three or four legs (13b) provided below the casing (11), wherein
 each of the connection portions is located on one first straight line (L1) in top view, and at least one of the legs (13b) exists on a second straight line (L2) that passes through a center of the casing (11) and is orthogonal to the first straight line (L1) in top view.
9. A scroll compressor (10) comprising:
 20 two or three connection portions among a first connection portion (21A) connecting a suction pipe (21), a second connection portion (22A) connecting a discharge pipe (22), and a third connection portion (23A) connecting an injection pipe (23); and
 25 a scroll compression mechanism (50) including a fixed scroll (60), a movable scroll (70), and an Oldham coupling (80), wherein
 an angle formed by a first straight line (L1) in which a pipe fixing member (24) fixing two or three pipes among the suction pipe (21), the discharge pipe (22), and the injection pipe (23) extends in top view and a reciprocating direction of the Oldham coupling (80) is 10° or less.
 35
10. A heat source unit (3) of a refrigerant cycle apparatus (1), the heat source unit (3) comprising:
 40 the scroll compressor (10) according to claim 9; a suction pipe (21) including a first vertical portion (21B) connected to a first connection portion (21A);
 45 a discharge pipe (22) including a second vertical portion (22B) connected to a second connection portion (22A);
 an injection pipe (23) including a third vertical portion (23B) connected to a third connection portion (23A); and
 50 a pipe fixing member (24) that fixes two or three pipes among the suction pipe (21), the discharge pipe (22), and the injection pipe (23) at the vertical portions.
11. The heat source unit (3) of the refrigerant cycle apparatus (1) according to claim 10, wherein
 55 the pipe fixing member (24) fixes the discharge pipe (22) and the injection pipe (23).

12. The heat source unit (3) of the refrigerant cycle apparatus (1) according to claim 10, wherein the pipe fixing member (24) fixes the suction pipe (21) and the injection pipe (23). 5
13. The heat source unit (3) of the refrigerant cycle apparatus (1) according to claim 10, wherein the pipe fixing member (24) fixes the discharge pipe (22) and the suction pipe (21). 10
14. The heat source unit (3) of the refrigerant cycle apparatus (1) according to claim 10, wherein the pipe fixing member (24) fixes the suction pipe (21), the discharge pipe (22), and the injection pipe (23). 15
15. The heat source unit (3) of the refrigerant cycle apparatus (1) according to any one of claims 10 to 14, wherein the pipe fixing member (24) is made from metal. 20

25

30

35

40

45

50

55

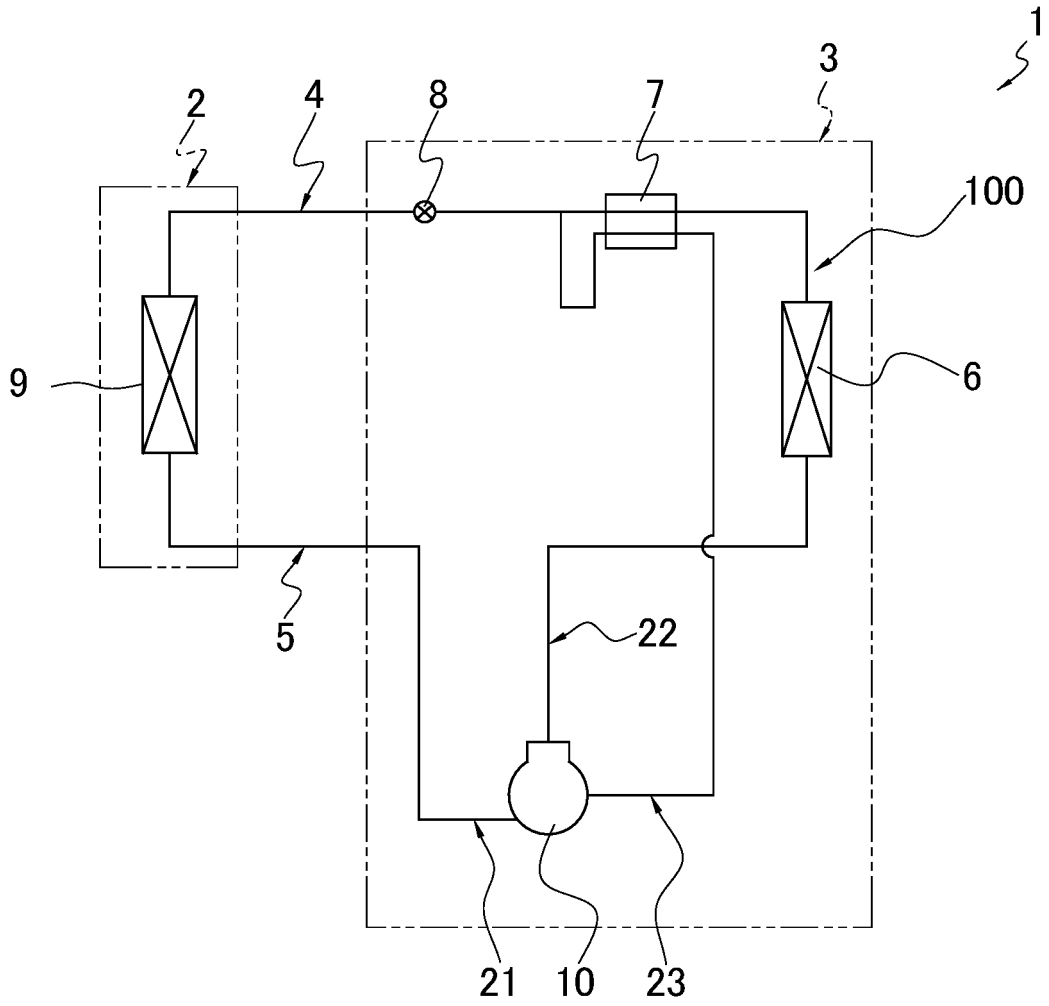

FIG. 1

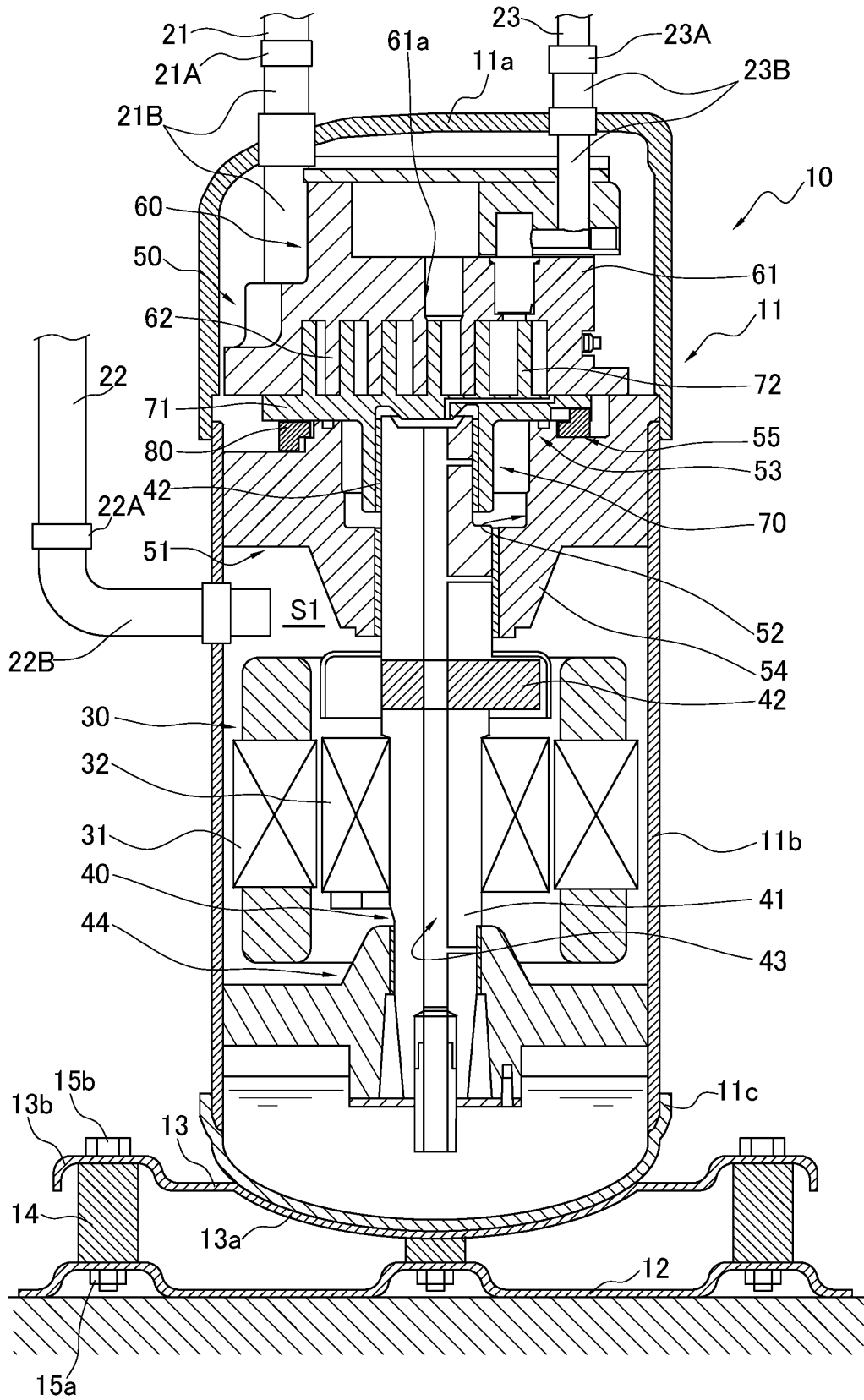

FIG. 2

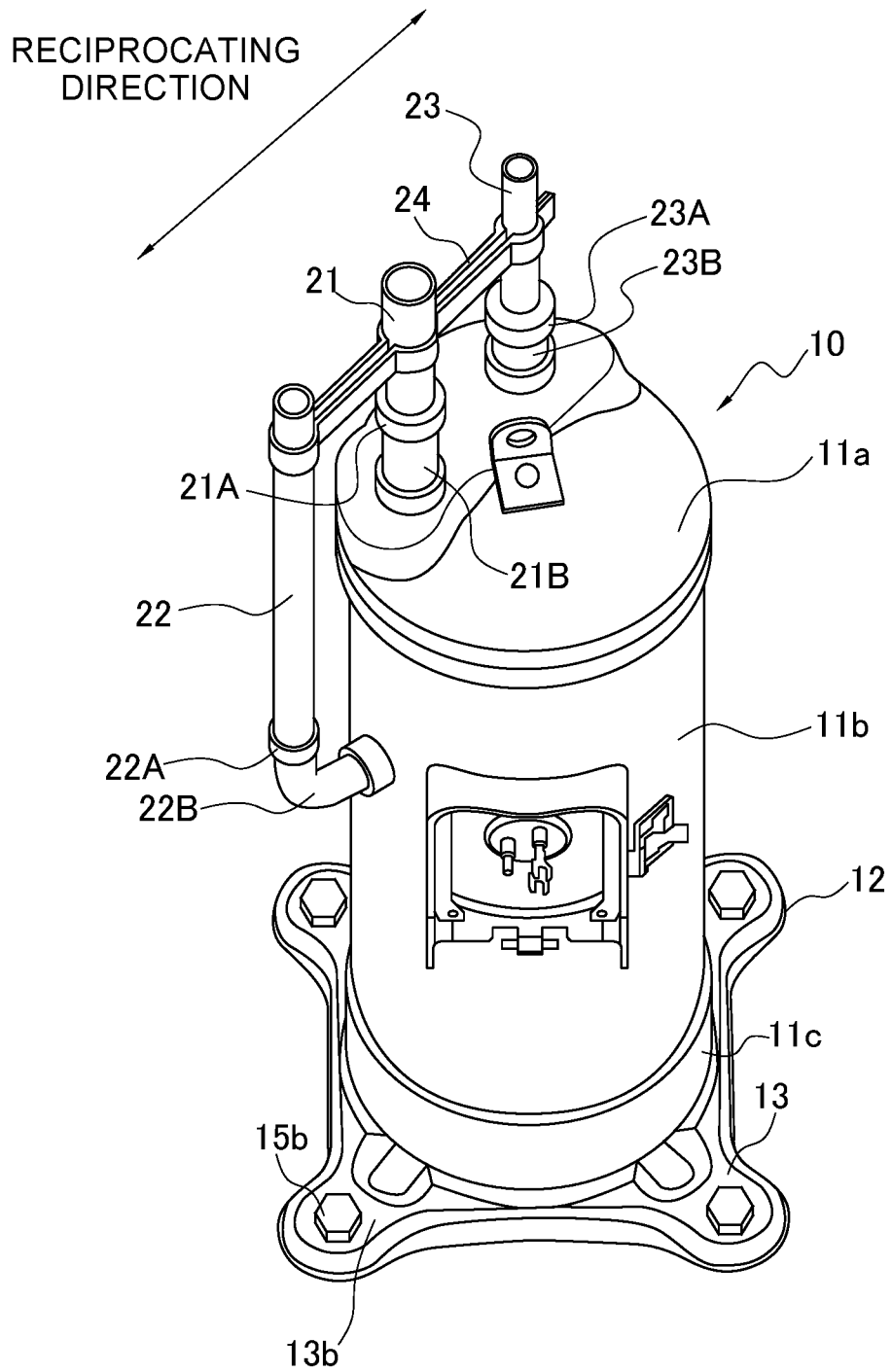

FIG. 3

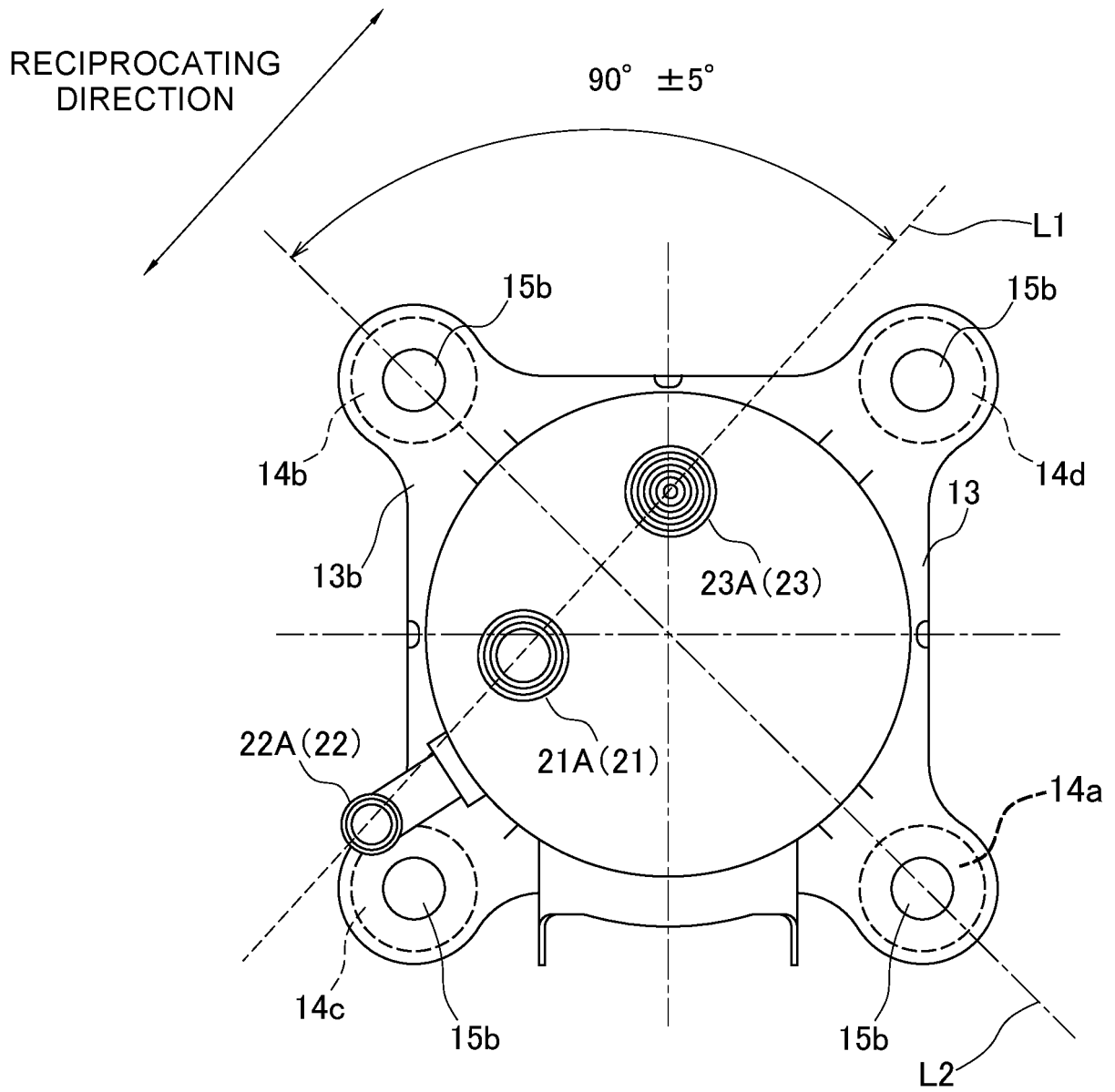

FIG. 4

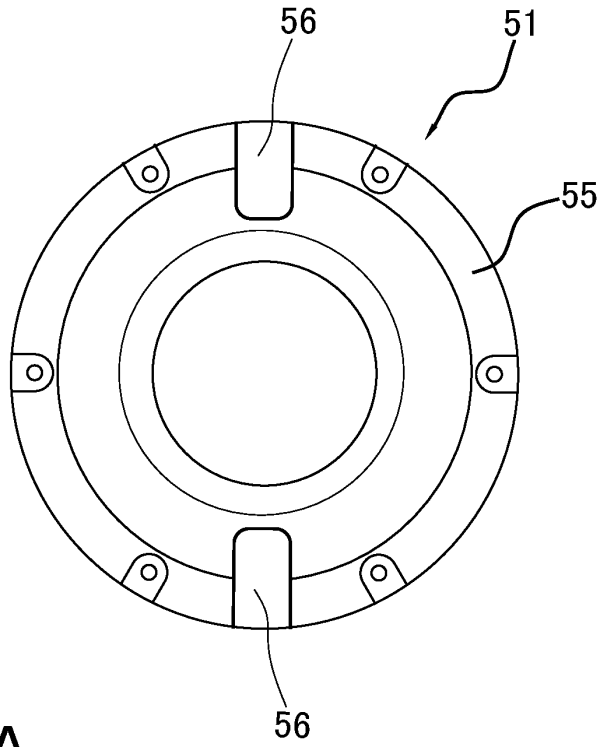

FIG. 5A

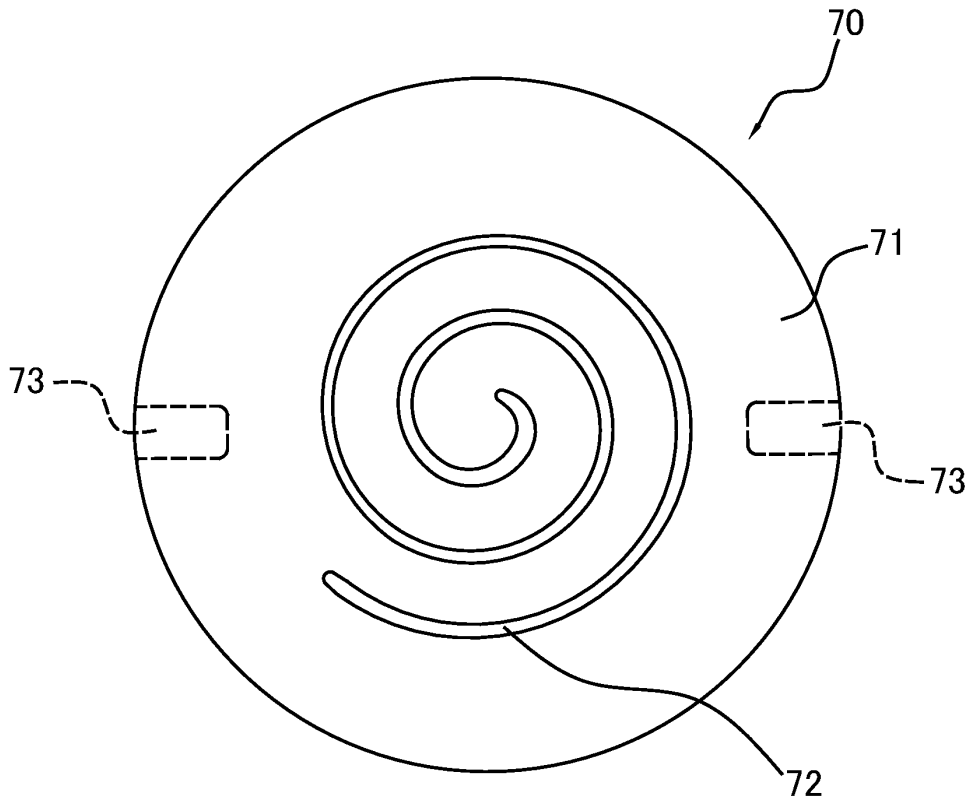

FIG. 5B

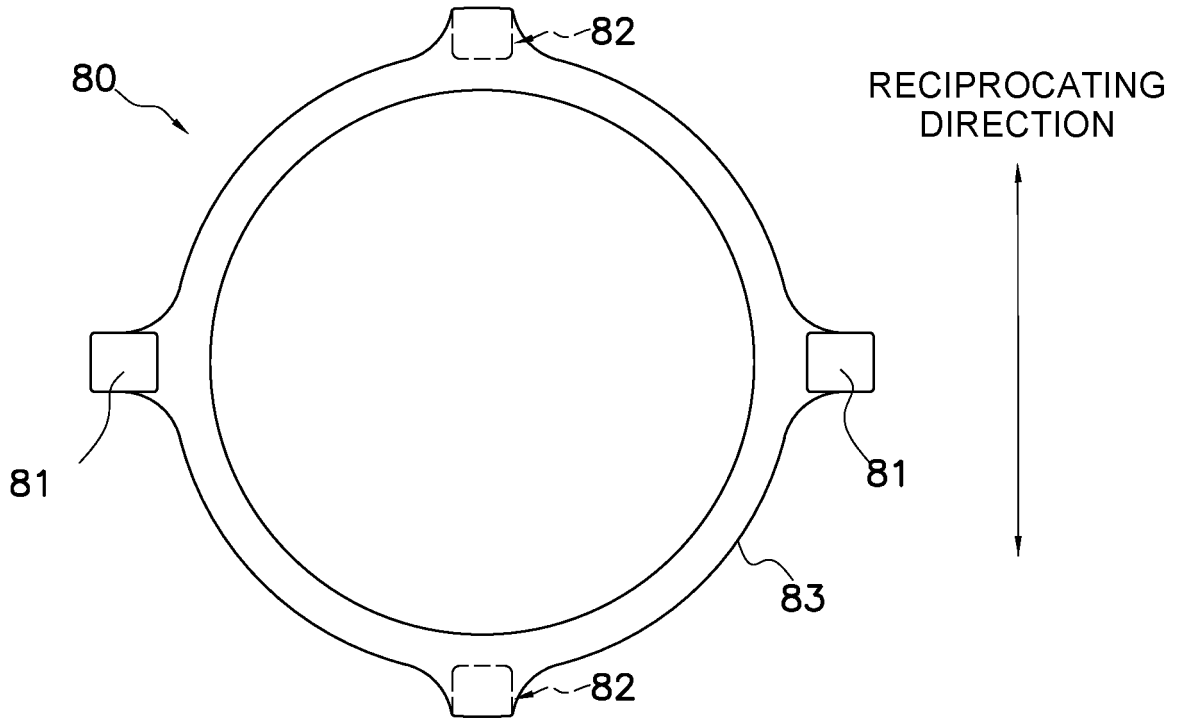

FIG. 6A

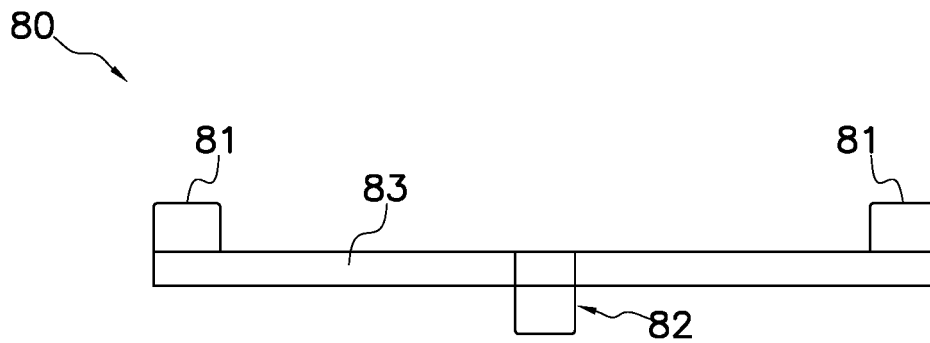

FIG. 6B

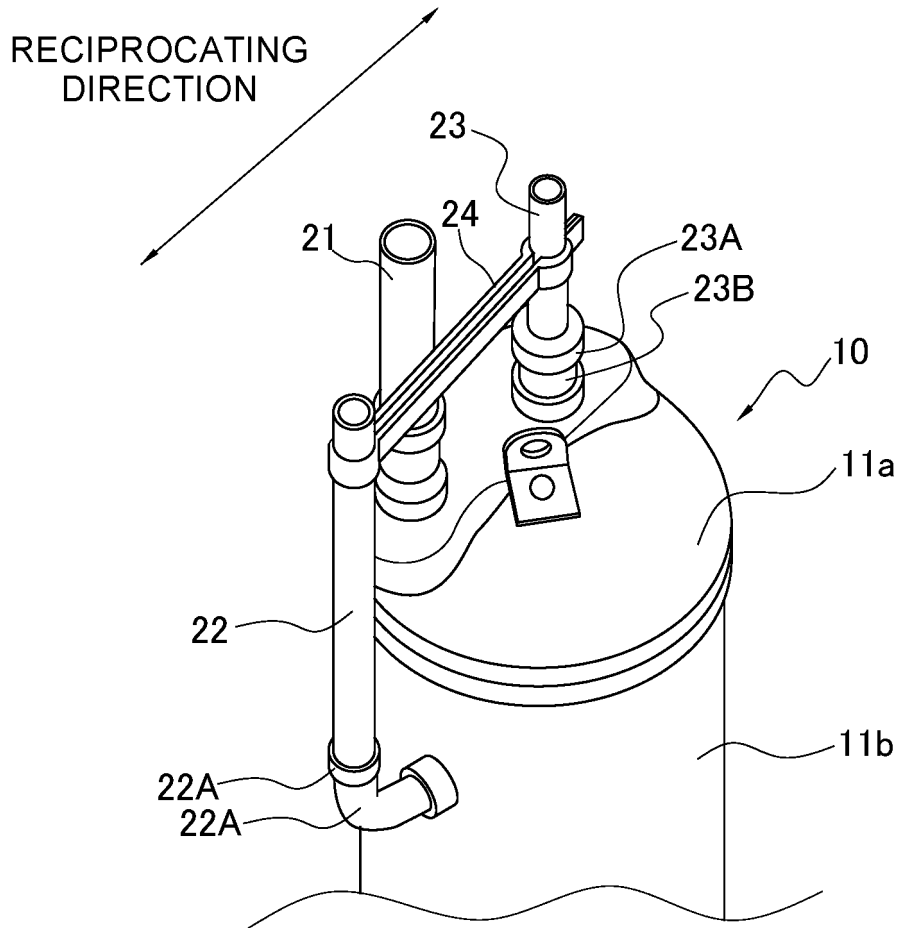

FIG. 7

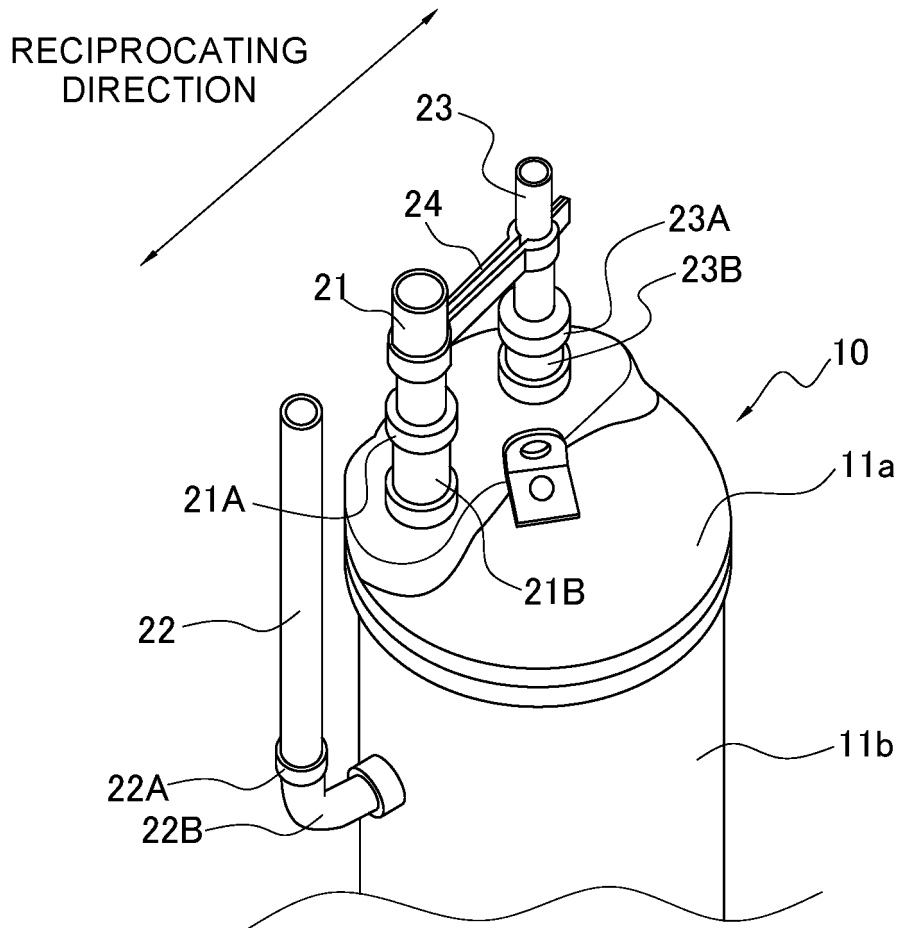

FIG. 8

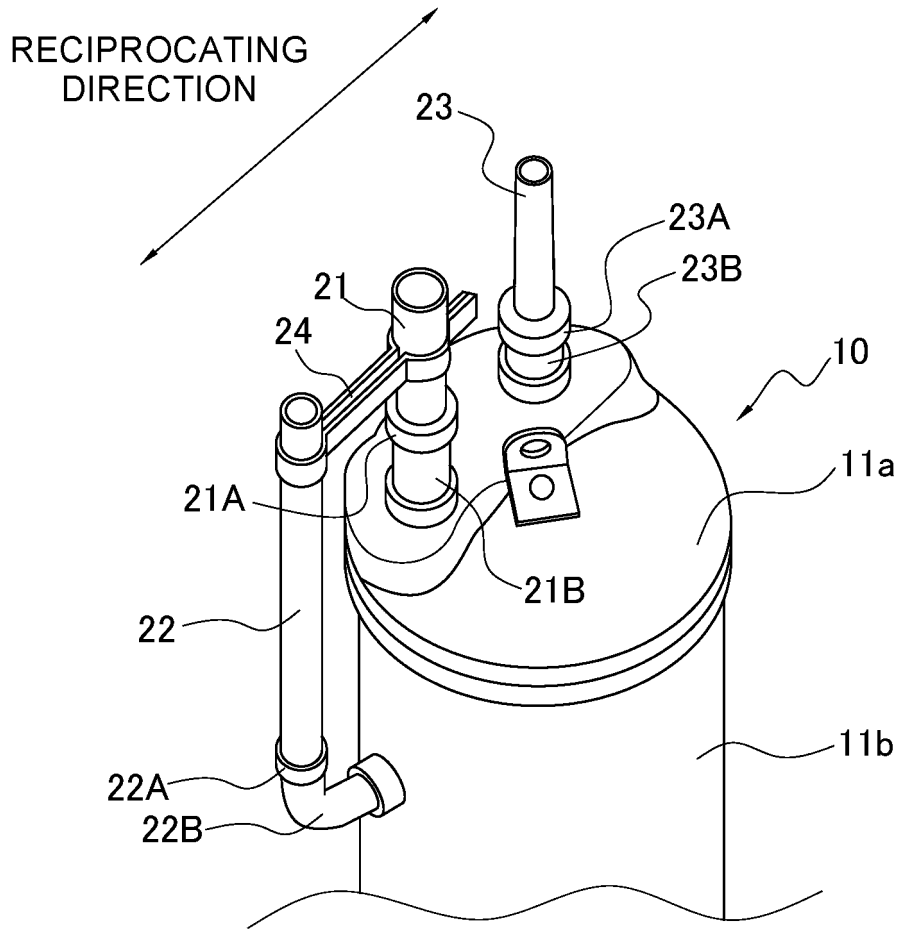

FIG. 9

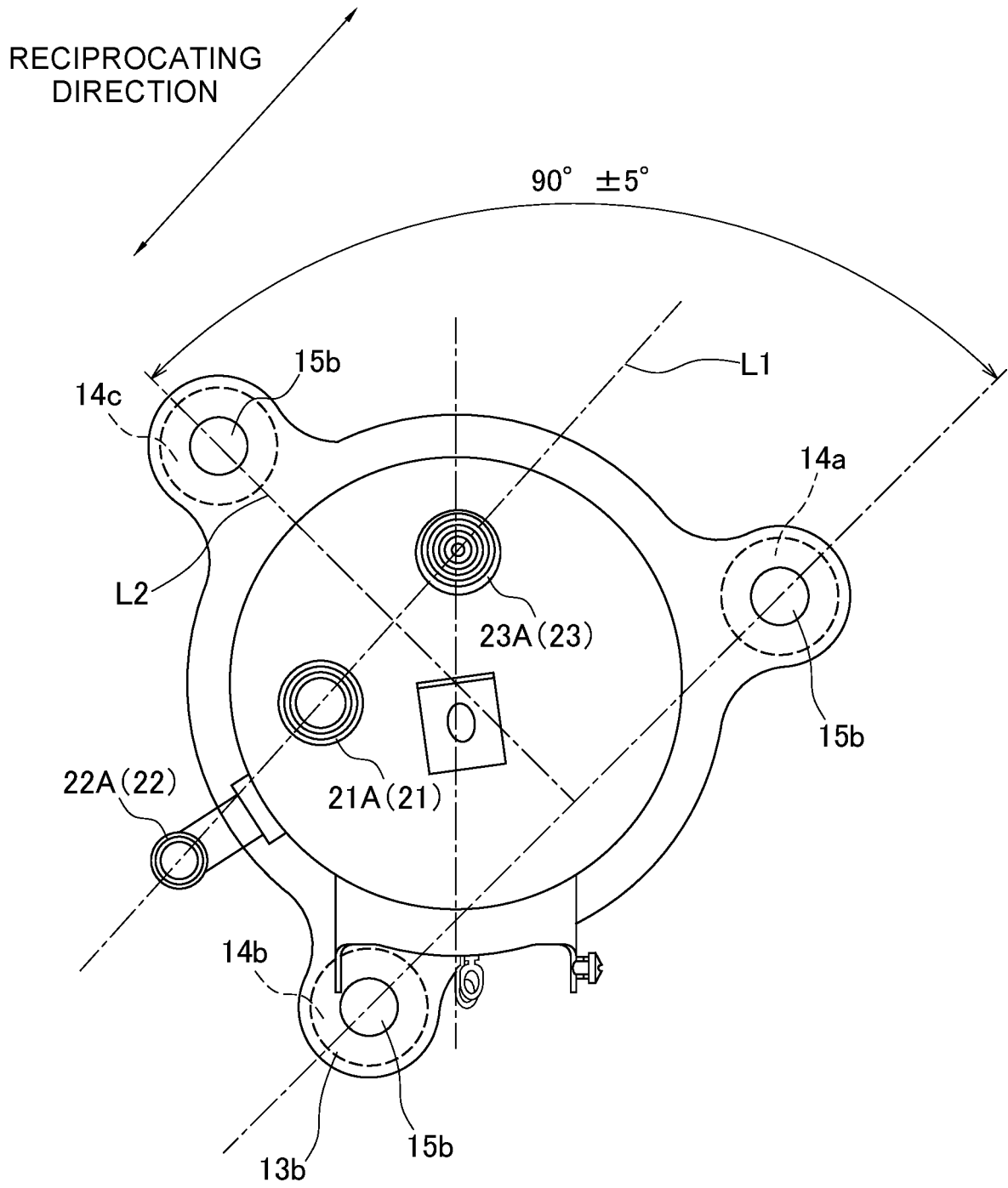

FIG. 10

INTERNATIONAL SEARCH REPORT

International application No.
PCT/JP2021/024166

5

A. CLASSIFICATION OF SUBJECT MATTER
Int. Cl. F04C29/06 (2006.01) i, F04B39/00 (2006.01) i, F04C29/12 (2006.01) i, F24F1/12 (2011.01) i
FI: F04C29/06 C, F04B39/00 102S, F24F1/12, F04C29/12 D, F04B39/00 102V
According to International Patent Classification (IPC) or to both national classification and IPC

10

B. FIELDS SEARCHED
Minimum documentation searched (classification system followed by classification symbols)
Int. Cl. F04C29/06, F04B39/00, F04C29/12, F24F1/12

15

Documentation searched other than minimum documentation to the extent that such documents are included in the fields searched
Published examined utility model applications of Japan 1922-1996
Published unexamined utility model applications of Japan 1971-2021
Registered utility model specifications of Japan 1996-2021
Published registered utility model applications of Japan 1994-2021

20

Electronic data base consulted during the international search (name of data base and, where practicable, search terms used)

C. DOCUMENTS CONSIDERED TO BE RELEVANT

25

Category*	Citation of document, with indication, where appropriate, of the relevant passages	Relevant to claim No.
A	JP 2018-9543 A (DAIKIN INDUSTRIES, LTD.) 18 January 2018 (2018-01-18), entire text, all drawings	1-15
A	JP 2017-186924 A (DAIKIN INDUSTRIES, LTD.) 12 October 2017 (2017-10-12), entire text, all drawings	1-15

30

35

40

Further documents are listed in the continuation of Box C. See patent family annex.

45

* Special categories of cited documents:
 "A" document defining the general state of the art which is not considered to be of particular relevance
 "E" earlier application or patent but published on or after the international filing date
 "L" document which may throw doubts on priority claim(s) or which is cited to establish the publication date of another citation or other special reason (as specified)
 "O" document referring to an oral disclosure, use, exhibition or other means
 "P" document published prior to the international filing date but later than the priority date claimed
 "T" later document published after the international filing date or priority date and not in conflict with the application but cited to understand the principle or theory underlying the invention
 "X" document of particular relevance; the claimed invention cannot be considered novel or cannot be considered to involve an inventive step when the document is taken alone
 "Y" document of particular relevance; the claimed invention cannot be considered to involve an inventive step when the document is combined with one or more other such documents, such combination being obvious to a person skilled in the art
 "&" document member of the same patent family

50

Date of the actual completion of the international search 19.07.2021
Date of mailing of the international search report 03.08.2021

55

Name and mailing address of the ISA/
Japan Patent Office
3-4-3, Kasumigaseki, Chiyoda-ku,
Tokyo 100-8915, Japan
Authorized officer
Telephone No.

INTERNATIONAL SEARCH REPORT
Information on patent family members

International application No.
PCT/JP2021/024166

5
10
15
20
25
30
35
40
45
50
55

Patent Documents referred to in the Report	Publication Date	Patent Family	Publication Date
JP 2018-9543 A	18.01.2018	(Family: none)	
JP 2017-186924 A	12.10.2017	(Family: none)	

Form PCT/ISA/210 (patent family annex) (January 2015)

REFERENCES CITED IN THE DESCRIPTION

This list of references cited by the applicant is for the reader's convenience only. It does not form part of the European patent document. Even though great care has been taken in compiling the references, errors or omissions cannot be excluded and the EPO disclaims all liability in this regard.

Patent documents cited in the description

- JP 2011094914 A [0003] [0093]
- JP H02485 A [0016] [0093]