



(19) **United States**

(12) **Patent Application Publication**

Terry et al.

(10) **Pub. No.: US 2016/0233977 A1**

(43) **Pub. Date: Aug. 11, 2016**

(54) **USER EQUIPMENT USING HYBRID
AUTOMATIC REPEAT REQUEST**

Publication Classification

(71) Applicant: **Intel Corporation**, Santa Clara, CA (US)
(72) Inventors: **Stephen E. Terry**, Northport, NY (US);
Ariela Zeira, Huntington, NY (US);
Nader Bolourchi, Elizabeth, NY (US)

(51) **Int. Cl.**
H04L 1/00 (2006.01)
H04W 72/04 (2006.01)
H04L 5/00 (2006.01)
H04L 1/18 (2006.01)
(52) **U.S. Cl.**
CPC *H04L 1/0003* (2013.01); *H04L 1/1822*
(2013.01); *H04W 72/0413* (2013.01); *H04L*
5/0055 (2013.01); *H04W 72/042* (2013.01)

(21) Appl. No.: **15/132,096**

(22) Filed: **Apr. 18, 2016**

(57) **ABSTRACT**

A user equipment comprises a transmitter and an adaptive modulation and coding controller. The transmitter is configured to transmit data over an air interface in a single transmission time interval with a first specified modulation and coding scheme, where the single transmission time interval has a plurality of transport block sets. In response to receiving a repeat request for retransmission of at least one particular transport block set, the transmitter retransmits the at least one of the particular transport block sets. The adaptive modulation and coding controller is configured to change the specified modulation and coding scheme to a second specified modulation and coding scheme, enabling a combining of a particular transport block set transmitted at the first specified modulation and coding scheme with a retransmitted version of the particular transport block set transmitted at the second specified modulation and coding scheme.

Related U.S. Application Data

(63) Continuation of application No. 14/302,123, filed on Jun. 11, 2014, now Pat. No. 9,344,252, which is a continuation of application No. 13/722,798, filed on Dec. 20, 2012, now Pat. No. 8,756,471, which is a continuation of application No. 13/311,148, filed on Dec. 5, 2011, now Pat. No. 8,341,482, which is a continuation of application No. 11/975,749, filed on Oct. 22, 2007, now Pat. No. 8,074,140, which is a continuation of application No. 10/279,393, filed on Oct. 24, 2002, now Pat. No. 7,287,206.
(60) Provisional application No. 60/357,224, filed on Feb. 13, 2002.

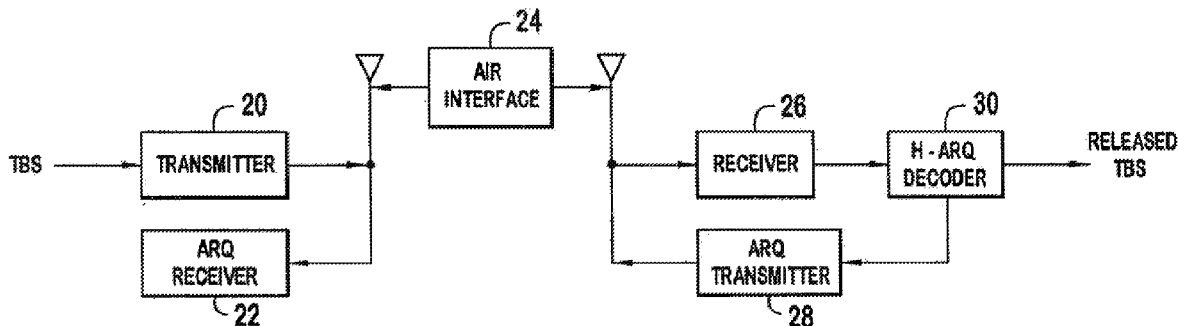

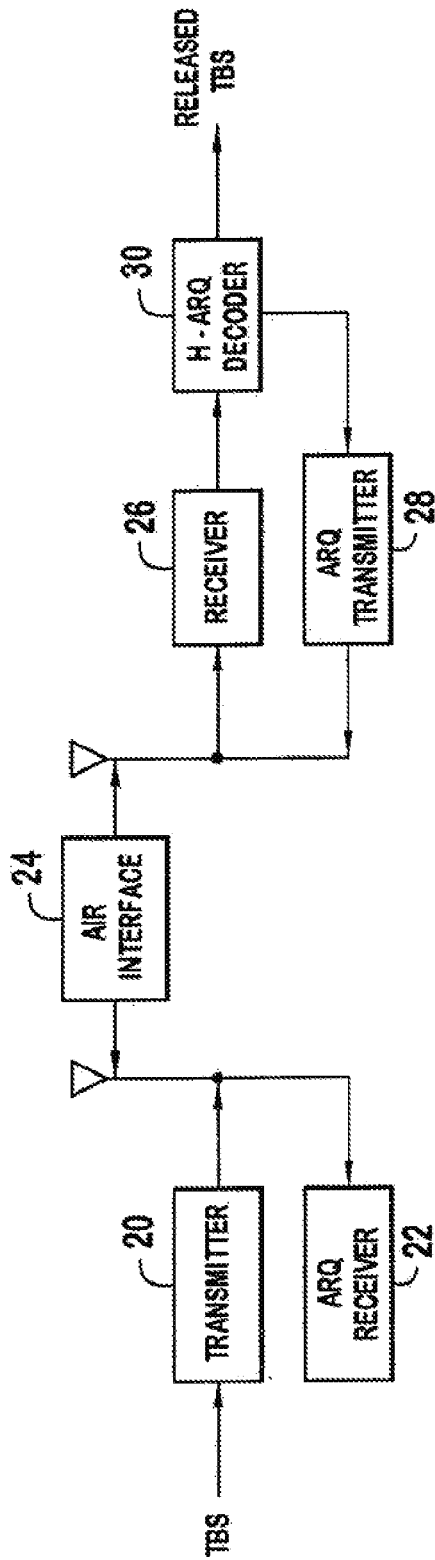

FIG. 1

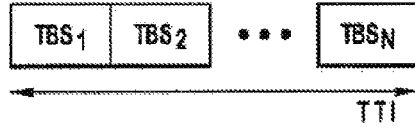

FIG. 2A

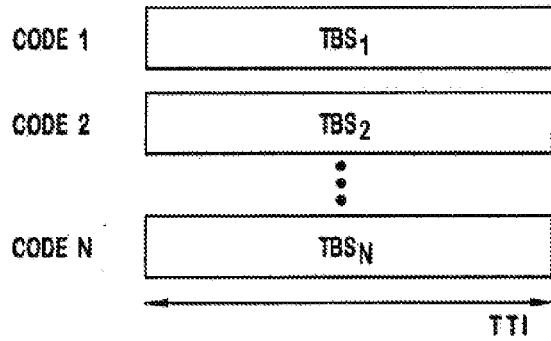

FIG. 2B

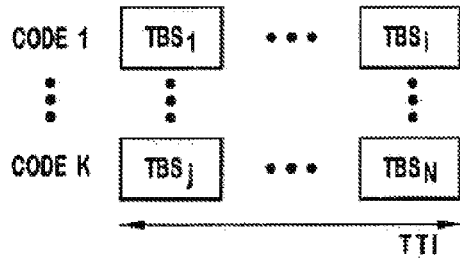

FIG. 2C

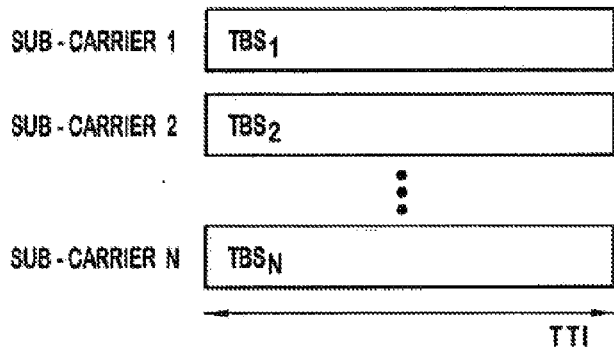

FIG. 2D

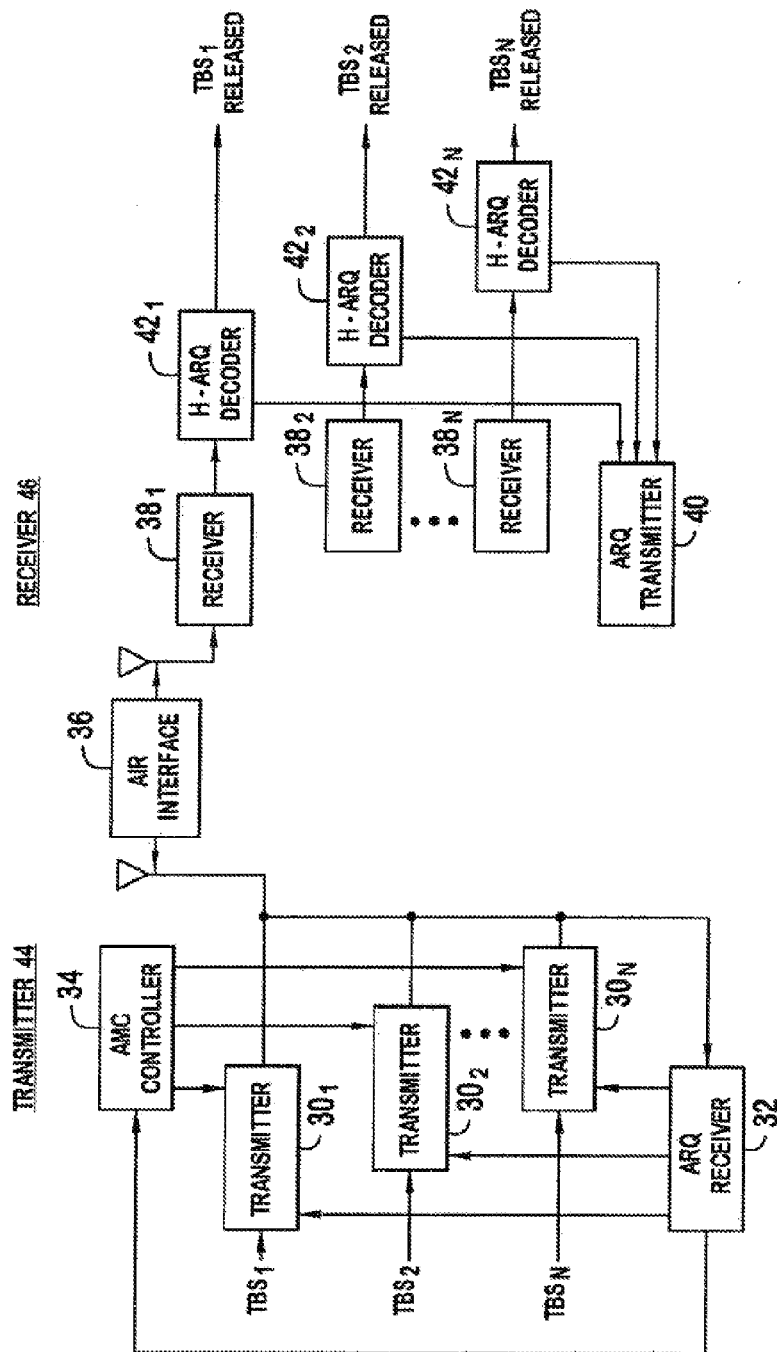

FIG. 3A

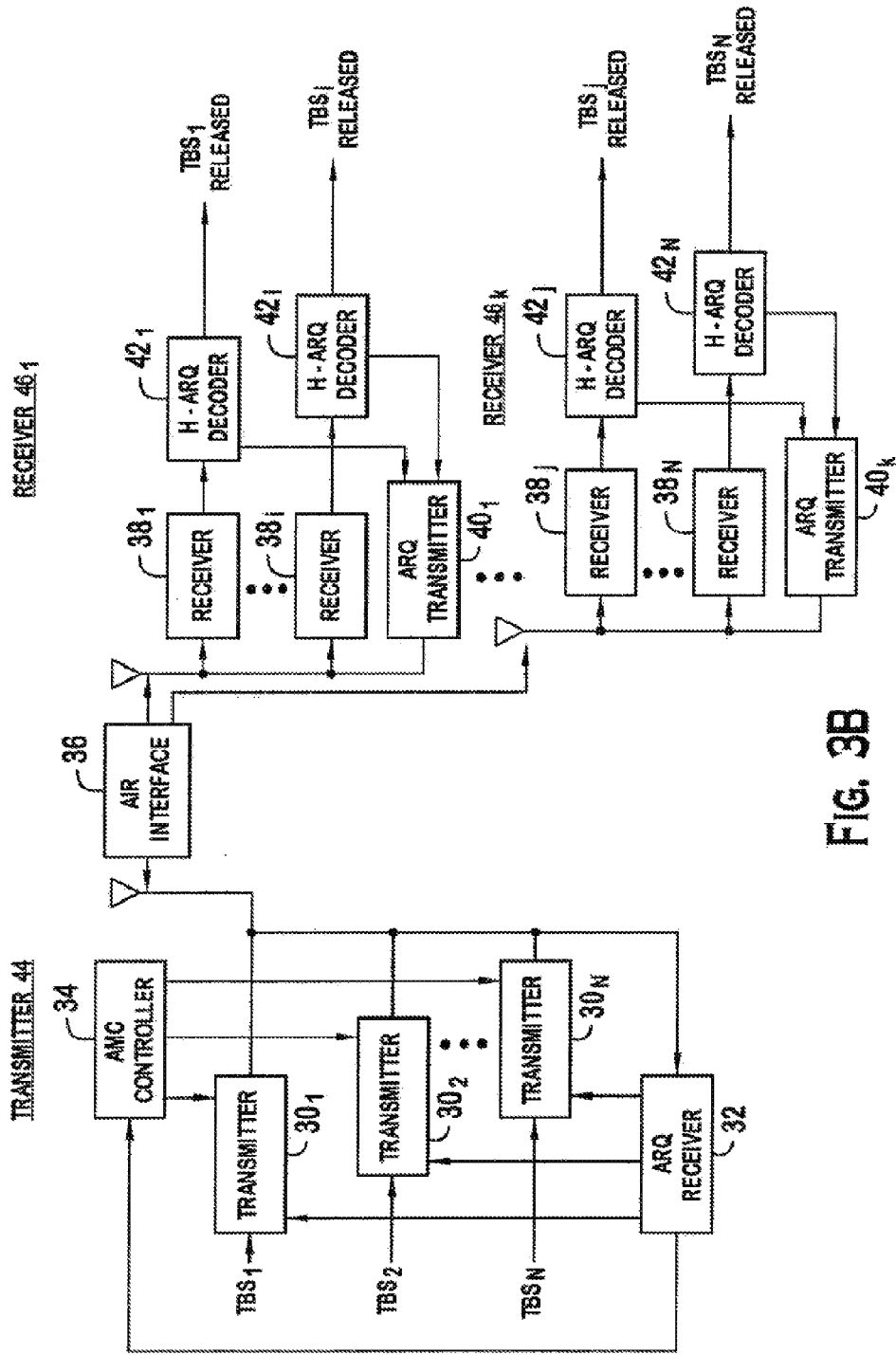

FIG. 3B

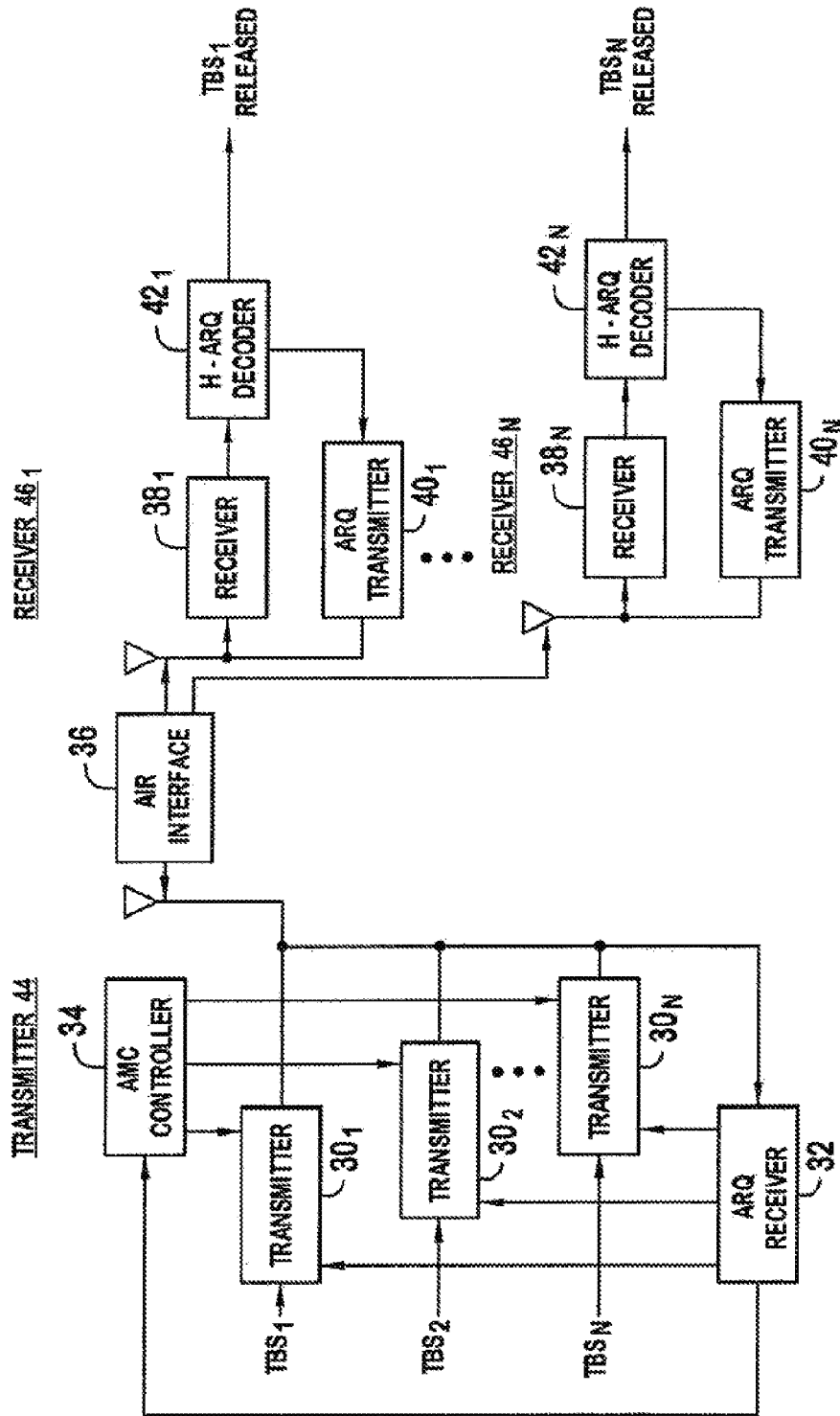

FIG. 3C

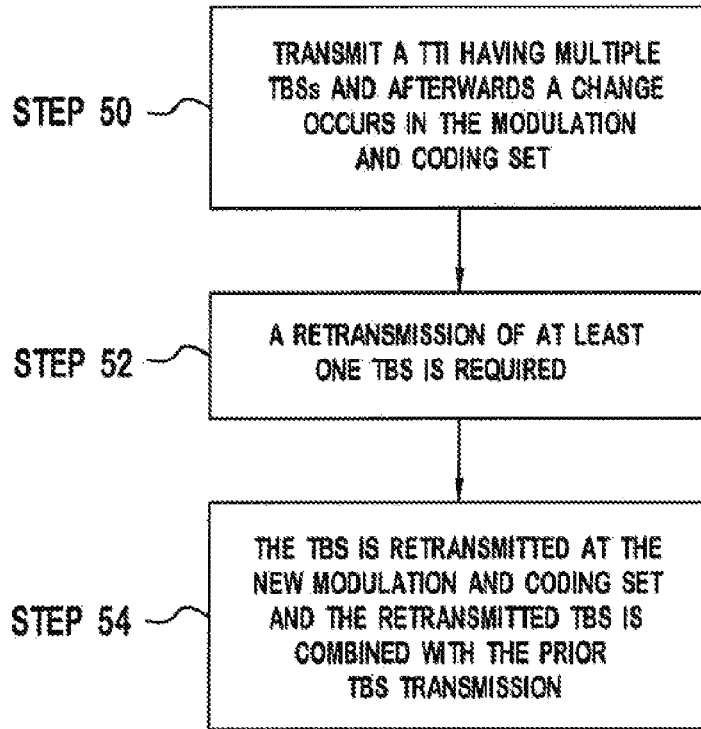

FIG. 4

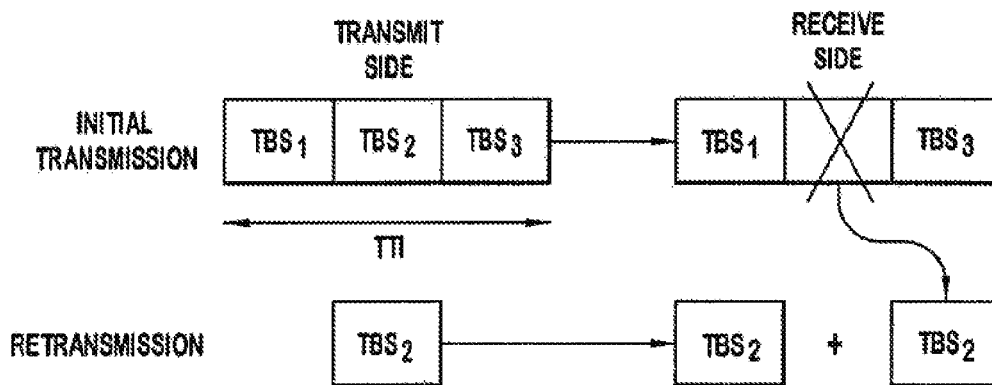

FIG. 5

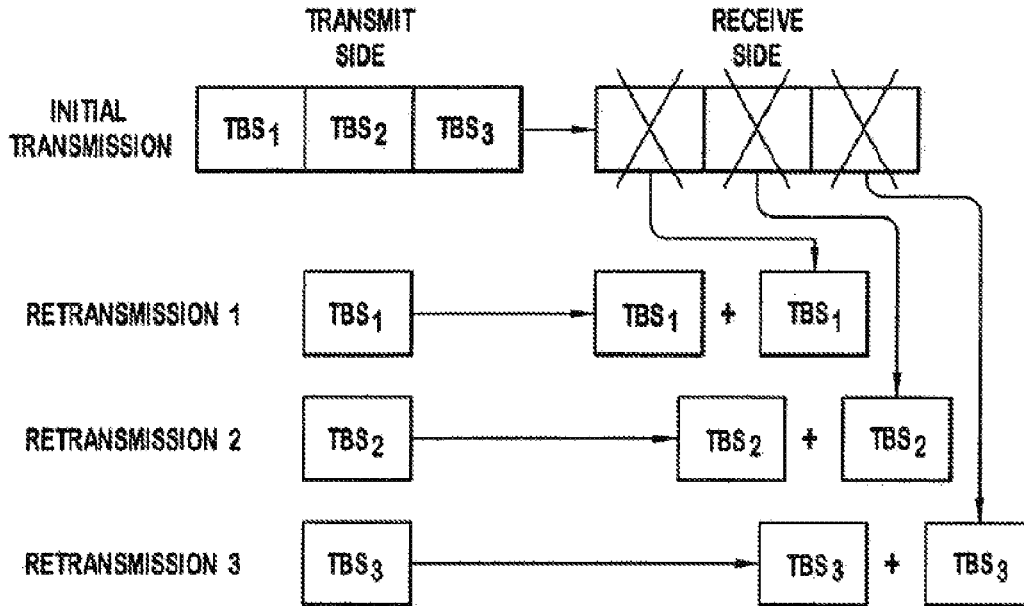

FIG. 6

		TIMESLOTS				
		1	2	3	4	N
CODES	1	A	A	B		...
	2	A	A	B		...
	3	A	B	B		...
	⋮	⋮	⋮	⋮	⋮	⋮
	M	A	B	B		...

FIG. 7

		TIMESLOTS				
		1	2	3	4	N
CODES	1	A	A	B	B	...
	2	A	A	B	B	...
	3	A		B		...
	⋮	⋮	⋮	⋮	⋮	⋮
	M	A		B		...

FIG. 8

USER EQUIPMENT USING HYBRID AUTOMATIC REPEAT REQUEST

CROSS REFERENCE TO RELATED APPLICATIONS

[0001] This application is a continuation of U.S. patent application Ser. No. 14/302,123 filed Jun. 11, 2014, which is a continuation of U.S. patent application Ser. No. 13/722,798 filed Dec. 20, 2012, which issued on Jun. 17, 2014 as U.S. Pat. No. 8,756,471, which is a continuation of U.S. patent application Ser. No. 13/311,148 filed Dec. 5, 2011, which issued on Dec. 25, 2012 as U.S. Pat. No. 8,341,482, which is a continuation of U.S. patent application Ser. No. 11/975,749, filed Oct. 22, 2007, which issued on Dec. 6, 2011 as U.S. Pat. No. 8,074,140, which is a continuation of U.S. patent application Ser. No. 10/279,393, filed Oct. 24, 2002, which issued on Oct. 23, 2007 as U.S. Pat. No. 7,287,206, which claims priority to U.S. Provisional Application No. 60/357,224, filed Feb. 13, 2002, the contents of which are hereby incorporated by reference herein.

[0002] This invention generally relates to wireless communication systems. In particular, the invention relates to transmission of data in such systems where adaptive modulation & coding (AMC) and hybrid automatic repeat request (H-ARQ) techniques are applied.

[0003] In wireless communication systems, such as the third generation partnership project (3GPP) time division duplex (TDD) or frequency division duplex (FDD) communication systems using code division multiple access (CDMA) or orthogonal frequency division multiplex (OFDM) systems, AMC is used to optimize the use of air resources.

[0004] The modulation and coding schemes (sets) used to transmit data are varied based on wireless channel conditions. To illustrate, a type of error encoding (such as turbo versus convolutional coding), coding rate, spreading factor for CDMA system, modulation type (such as quadrature phase shift keying versus M-ary quadrature amplitude modulation), and/or adding/subtracting sub-carriers for an OFDM system may change. If channel characteristics improve, a lower data redundancy and/or "less robust" modulation and coding set is used to transfer data. As a result, for a given allocation of radio resources, more user data is transferred resulting in a higher effective data rate. Conversely, if channel characteristics degrade, a higher data redundancy "more robust" modulation and coding set is used, transferring less user data. Using AMC, an optimization between air resource utilization and quality of service (QOS) can be better maintained.

[0005] Data in such systems is received for transfer over the air interface in transmission time intervals (TTIs). Data within a TTI transferred to a particular user equipment is referred to as a transport block set (TBS). For a particular allocation of air resources, a less robust modulation and coding set allows for larger TBS sizes and a more robust modulation and coding set only allows for smaller TBS sizes. As a result, the modulation and coding set for a given radio resource allocation dictates the maximum size of the TBS that can be supported in a given TTI.

[0006] In such systems, a hybrid automatic repeat request (H-ARQ) mechanism may be used to maintain QOS and improve radio resource efficiency. A system using H-ARQ is shown in FIG. 1. A transmitter **20** transmits a TBS over the air interface **24** using a particular modulation and coding set. The TBS is received by a receiver **26**. An H-ARQ decoder **30**

decodes the received TBS. If the quality of the received data is unacceptable, an ARQ transmitter **28** requests a retransmission of the TBS. One approach to check the quality of the received TBS is a cyclic redundancy check (CRC). An ARQ receiver **22** receives the request and a retransmission of the TBS is made by the transmitter **20**. Retransmissions may apply a more robust modulation and coding set to increase the possibility of successful delivery. The H-ARQ decoder **30** combines the received TBS versions. A requirement for combining is that combined TBSs are identical. If the resulting quality is still insufficient, another retransmission is requested. If the resulting quality is sufficient, such as the combined TBS passes the CRC check, the received TBS is released for further processing. The H-ARQ mechanism allows for data received with unacceptable quality to be retransmitted to maintain the desired QOS.

[0007] In a system using both H-ARQ and AMC, a change in modulation and coding set may be determined necessary to achieve successful delivery of a requested TBS retransmission. In this situation, the maximum amount of physical data bits allowed within the TTI varies with the modulation and coding set.

[0008] Since only one TBS exists per TTI the effective user data rate corresponds to the TBS size applied to each TTI. To achieve maximum data rates the largest TBS size is applied to the least robust modulation and coding set within the TTI. When wireless channel conditions require a more robust modulation and coding set for successful transmission, such as when a TBS size cannot be supported within the TTI. Therefore, when operating at the maximum data rate, each time a more robust modulation and coding requirement is realized, all outstanding transmissions in H-ARQ processes that have not been successfully acknowledged must be discarded.

[0009] When Incremental Redundancy (IR) is applied, TBS data must remain constant in retransmissions for proper combining. Therefore, to guarantee that a TBS retransmission can be supported at a more robust modulation and coding set than the initial transmission, the TBS size used must correspond to the most robust MCS. However, when a TBS size allowed by the most robust modulation and coding set is applied the maximum data rate to the mobile is reduced, and when a less robust modulation and coding set is applied physical resources are not fully utilized.

[0010] When the TBS size is not supported by the more robust modulation and coding set, the TBS can be retransmitted using the old modulation and coding set. However, if the channel conditions dictate that a more robust modulation and coding set be used or the initial transmission was severely corrupted, the combining of the retransmitted TBSs may never pass, resulting in a transmission failure.

[0011] In current implementations, when a TBS cannot be successfully transmitted by AMC & H-ARQ mechanisms, recovery is handled by the radio link control (RLC) protocol (at layer two). Unlike a H-ARQ recovery of failed transmissions, the RLC error detection, data recovery and buffering of a TBS queued in the node-B, results in increased block error rates and data latency, potentially resulting in a failure to meet QOS requirements.

[0012] Accordingly, to provide maximum data rates with minimal H-ARQ transmission failures, it is desirable to support incremental redundancy and allow adaptation of modulation and coding sets in such systems.

SUMMARY

[0013] A user equipment comprises a transmitter and an adaptive modulation and coding controller. The transmitter is configured to transmit data over an air interface in a single transmission time interval with a first specified modulation and coding scheme, where the single transmission time interval has a plurality of transport block sets. In response to receiving a repeat request for retransmission of at least one particular transport block set, the transmitter retransmits the at least one of the particular transport block sets. The adaptive modulation and coding controller is configured to change the specified modulation and coding scheme to a second specified modulation and coding scheme, enabling a combining of a particular transport block set transmitted at the first specified modulation and coding scheme with a retransmitted version of the particular transport block set transmitted at the second specified modulation and coding scheme.

BRIEF DESCRIPTION OF THE DRAWINGS

[0014] FIG. 1 is an embodiment of a wireless H-ARQ communication system.

[0015] FIGS. 2A-2D are illustrations of a TTI having multiple TBSs.

[0016] FIGS. 3A-3C are embodiments of a wireless H-ARQ communication system using AMC with TTIs capable of having multiple TBSs.

[0017] FIG. 4 is a flow chart of changing the modulation and coding set prior to a H-ARQ retransmission.

[0018] FIG. 5 is an illustration of changing the modulation and coding set prior to a retransmission of a single TBS.

[0019] FIG. 6 is an illustration of changing the modulation and coding set prior to a retransmission of all three TBSs.

[0020] FIG. 7 is an illustration of overlapping TBSs in a TDD/CDMA communication system.

[0021] FIG. 8 is an illustration of non-overlapping TBSs in a TDD/CDMA communication system.

DETAILED DESCRIPTION OF THE PREFERRED EMBODIMENTS

[0022] FIGS. 2A, 2B, 2C and 2D illustrate a TTI having multiple TBSs, TBS₁ to TBS_N. FIG. 2A illustrates multiple TBSs dividing a TTI by time, such as for use in a TDD/CDMA system. FIG. 2B illustrates multiple TBSs divided by codes, such as for use in a FDD/CDMA or TDD/CDMA system. FIG. 2C illustrates dividing multiple TBSs by time and codes, such as for use in TDD/CDMA system. FIG. 2D illustrates dividing multiple TBSs by sub-carriers, such as for use in an OFDM system. Each TBS is sized to allow transmission with the most robust modulation coding set for the allocated resources. To illustrate, the most robust MCS may only have the capacity to support a maximum 2,000 bit TBS within the TTI. Although referred to as the most robust modulation coding set, in practice, the most robust set may actually be a more robust set, if the most robust modulation coding set is unlikely to be needed. The least robust modulation and coding set may have the capacity to support a maximum of 20,000 bit TBS within the TTI. Although referred to as the least robust modulation coding set, in practice, the least robust set may actually be a less robust set, if the least robust modulation coding set is unlikely to be needed.

[0023] The TBS is sized, preferably, to allow for transmission with the most robust modulation and coding set within a TTI. Then when the least robust modulation and coding set is

applied, multiple TBSs of this size are applied within the TTI to achieve maximum data rates, and when greater transmission reliability is required for successful delivery the most robust modulation and coding set can be applied.

[0024] FIG. 3A is a simplified diagram of a transmitter 44 and receiver 46 for transmitting a TTI having one or multiple TBSs. The transmitter 44 may be located at either a user equipment or a base station/Node-B. The receiver 46 may be located at either a base station/Node-B or a user equipment. In current system implementations, AMC is typically only used in the downlink. Accordingly, the preferred implementation of transmission is for use in supporting AMC for the downlink. For other systems using AMC in the uplink, transport block set transmission can be applied to the uplink.

[0025] A transmitter 30₁ to 30_N (30) transmits each TBS, TBS₁ to TBS_N, over the air interface 36. The number of TBSs in the TTI depends on the TBS size and the modulation and coding set used for transmission. If the most robust modulation and coding set is used to ensure successful delivery, the TTI may only support one TBS. If a lesser robust modulation and coding set is used to achieve higher effective data rates, multiple TBSs are sent in the TTI. Alternately, some TBSs may be destined for a different receiver 46₁ to 46_K (46), as shown in FIG. 3B. Each TBS may also be sent to a different receiver 46₁ to 46_N (46), as shown in FIG. 3C. This flexibility allows for greater radio resource utilization and efficiency.

[0026] A receiver 38₁ to 38_N (38) receives each transmitted TBS. A H-ARQ decoder 42₁ to 42_N (42) decodes each received TBS. Although in FIG. 3 one transmitter 30, receiver 38 and H-ARQ decoder 42 is shown for each TBS, one transmitter 30, receiver 38 and H-ARQ decoder 42 may handle all the TBSs. For each TBS failing the quality test, a request for retransmission is made by the ARQ transmitter 40. An ARQ receiver 32 receives the request and directs the appropriate TBS(s) to be retransmitted. The retransmitted TBS(s) are combined by the H-ARQ decoder(s) 42 and another quality test is performed. Once the TBS(s) passes the quality test, it is released for further processing. Since a TTI can contain multiple TBSs, preferably, a failure in one TBS does not necessarily require retransmission of the entire TTI, which more efficiently utilizes the radio resources.

[0027] An AMC controller 34 is also shown in FIGS. 3A, 3B and 3C. If the channel conditions change, the AMC controller may initiate a change in the modulation and code set used to transfer data. FIG. 4 is a flow diagram illustrating such a change occurring in AMC between retransmissions. A TTI is transmitted having multiple TBSs and afterwards, a change in the modulation and coding set occurs, (step 50). To illustrate using FIG. 5, a TTI has three TBSs, TBS₁, TBS₂ and TBS₃ applied at the least robust modulation and coding set to achieve the maximum data rate. The modulation and coding set in FIG. 5 changes so that only one TBS can be transmitted subsequently. Referring back to FIG. 4, at least one of the TBSs is received with an unacceptable quality and a retransmission is required, (step 52). In the illustration of FIG. 5, TBS₂ requires retransmission, as shown by a large "X". The TBS requiring retransmission is sent at the new modulation and coding set and combined with the prior TBS transmission, (step 54). As shown in FIG. 5, only TBS₂ is retransmitted and it is combined with the prior TBS₂ transmission. Although this example illustrates sending only one TBS at the more robust modulation and coding set, it is also possible that two TBSs could be transmitted with the more robust modulation and coding set within the TTI.

[0028] FIG. 6 is an illustration of multiple TBSs requiring retransmission. Three TBSs, TBS₁, TBS₂ and TBS₃, are transmitted in a TTI. A change in the modulation and coding set occurs such that only one TBS can be sent at a time. All three TBSs are received with an unacceptable quality. A request for retransmission is sent for all three TBSs. Sequentially, each TBS is retransmitted, as shown by retransmission 1, retransmission 2 and retransmission 3 in separate TTIs. The retransmitted TBSs are combined with the prior transmissions. A similar procedure is used, if two TBSs are transmitted with the more robust modulation and coding set within the TTI.

[0029] As illustrated, multiple TBSs allow for maximum data rates and incremental redundancy. A TTI can be transmitted at the least robust modulation and coding set achieving the maximum data rate and subsequent H-ARQ retransmission can be made at a more robust modulation and coding set ensuring greater probability for successful transmission. By allowing incremental redundancy, radio resources can be used more aggressively. A more aggressive (less robust) modulation and coding set can be used to achieve higher data rates and radio resource efficiency, since transmission can be made using a more conservative (more robust) set to maintain QOS, if channel conditions degrade.

[0030] In a TDD/CDMA communication system, such as in the 3GPP system, two preferred approaches for implementing multiple TBSs within a TTI use either overlapping or non-overlapping time slots. In overlapping time slots, the TBSs may overlap in time. As illustrated in FIG. 7, a first TBS in a TTI uses the resource units having an "A" in them. A resource unit is the use of one code in a time slot. A second TBS has the "B" resource units. As shown in FIG. 7, in the second time slot, both the first and second TBS are transmitted. Accordingly, the two TBSs' transmissions overlap in time.

[0031] In non-overlapping TB Ss, each time slot only contains one TBS of a TTI. As illustrated in FIG. 8, a first TBS ("A") is the only TBS in slots one and two. The second TBS ("B") is the only TBS in slots three and four.

[0032] In a FDD/CDMA communication system, such as in the third generation partnership project proposed system, transmissions occur simultaneously. In a FDD/CDMA system, preferably each TBS is assigned a different code/frequency pair for transmission. In an OFDM system, preferably each TBS is assigned a separate sub-carrier for transmission.

1. A user equipment (UE), comprising:
 - a transmitter to transmit an uplink (UL) message over a third generation partnership project (3GPP) network according to an adaptive data transmission parameter, the UL message including a plurality of transport block (TB) sets in a first transmission time interval (TTI); and
 - a processor to selectively change the adaptive data transmission parameter based on a UL channel condition, wherein the transmitter is configured to retransmit, in a second TTI, a first TB of the plurality of TB sets according to the changed adaptive transmission parameter.
2. The UE of claim 1, wherein the adaptive data transmission parameter comprises an adaptive modulation and channel coding rate.
3. The UE of claim 2, wherein the processor is configured to selectively change the adaptive data transmission parameter from a first modulation comprising M-ary quadrature amplitude modulation (QAM) to a second modulation comprising phase shift keying (QPSK).

4. The UE of claim 1, further comprising:
 - a receiver to receive, through the 3GPP network, a negative acknowledgment (NACK) message associated with the first TB, wherein the processor is configured to selectively change the adaptive data transmission parameter in response to the NACK message.
5. The UE of claim 4, wherein the receiver is further configured to receive, through the 3GPP network, an acknowledgment (ACK) message associated with a second TB of the plurality of TB sets to indicate that the second TB does not require retransmission.
6. The UE of claim 1, the processor further configured for time division duplex using code division multiple access wherein the plurality of TB sets are separated by time.
7. The UE of claim 1, the processor further configured to use a code division multiple access wherein the plurality of TB sets are separated by codes.
8. The UE of claim 1, the processor further configured for time division duplex using code division multiple access wherein the TB sets are separated by time and codes.
9. The UE of claim 1, the processor further configured to use orthogonal frequency division multiple access wherein the TB sets are separated by sub-carriers.
10. A user equipment (UE) for communication over a third generation partnership project (3GPP) network, the UE comprising:
 - a receiver to receive a plurality of transport block (TB) sets in a first transmission time interval (TTI); and
 - a transmitter to transmit a negative acknowledgment (NACK) to request a retransmission of a subset of the plurality of TB sets, wherein the receiver is configured to receive the requested retransmission of the subset of the plurality of TB sets in a second TTI.
11. The UE of claim 10, further comprising:
 - a processor to combine the subset of the plurality of TB sets received in the second TTI with the subset of the plurality of TB sets received in the first TTI.
12. The UE of claim 10, further comprising:
 - a processor configured for adaptive modulation and coding (AMC), wherein the plurality of TB sets received in the first TTI comprises a first modulating and encoding scheme (MCS) and the subset of the plurality of TB sets received in the second TTI comprises a second MCS, the second MCS being different than the first MCS.
13. The UE of claim 10, wherein the receiver is further configured to:
 - receive the plurality of TB sets in the first TTI on a first plurality of sub-carriers; and
 - receive the subset of the plurality of TB sets in the second TTI on a second plurality of sub carriers, wherein the second plurality of sub-carriers are different than the first plurality of sub-carriers.
14. The UE of claim 10, wherein the transmitter is further configured to transmit an acknowledgment to indicate that one of the plurality of TB sets in the first TTI does not require a retransmission.
15. The UE of claim 10, wherein a determination to transmit the NACK is based upon a cyclic redundancy check (CRC).
16. A method to be performed by a Node-B in a third generation partnership project (3GPP) network, the method comprising:

transmitting, on a downlink (DL) channel of the Node-B, at least a first transport block (TB) set and a second TB set in a first transmission time interval (TTI);

receiving, on an uplink (UL) channel of the Node-B, a request to retransmit the first TB set, and retransmitting in response to the request, on the DL channel of the Node-B, the first TB set in a second TTI.

17. The method of claim **16**, further comprising: receiving, on the UL channel, an acknowledgment that the second TB set does not require retransmission.

18. The method of claim **16**, further comprising: transmitting, on the DL channel, cyclic redundancy check (CRC) bits associated with each of the first TB set and the second TB set.

19. The method of claim **16**, further comprising: processing the first TB set and the second TB set transmitted in the first TTI using a first modulating and encoding scheme (MCS);

and processing the first TB set retransmitted in the second TTI using a second MCS.

* * * * *