



US 20160235533A1

(19) **United States**

(12) **Patent Application Publication**
GILMORE et al.

(10) **Pub. No.: US 2016/0235533 A1**

(43) **Pub. Date: Aug. 18, 2016**

(54) **MULTIPLE ANCHORING-POINT TENSION SYSTEM**

Publication Classification

(71) Applicant: **4TECH INC.**, Newton, MA (US)

(51) **Int. Cl.**
A61F 2/24 (2006.01)
A61B 17/04 (2006.01)

(72) Inventors: **Michael GILMORE**, Ardrahan (IE);
Idan TOBIS, Beth Hashmonai (IL);
Charlotte MURPHY, Ardrahan (IE);
Kevin LYNN, Athenry (IE)

(52) **U.S. Cl.**
CPC *A61F 2/2442* (2013.01); *A61B 17/0401*
(2013.01); *A61B 17/0487* (2013.01); *A61B*
2017/0414 (2013.01); *A61B 2017/0441*
(2013.01); *A61B 2017/0464* (2013.01); *A61B*
2017/0496 (2013.01)

(73) Assignee: **4TECH INC.**, Newton, MA (US)

(57) **ABSTRACT**

(21) Appl. No.: **15/031,069**

A method is provided that includes implanting (a) a first venous tissue anchor in a superior vena cava, an inferior vena cava, or a coronary sinus, (b) exactly two atrial tissue anchors, which consist of second and third atrial tissue anchors, at respective different atrial sites, each of which sites is selected from: an annulus of a tricuspid valve, and a wall of a right atrium of a heart above the annulus, and (c) a pulley system, which includes (i) a pulley, which is connected to the second atrial tissue anchor, and (ii) a tether, which (A) is connected to the first venous tissue anchor and the third atrial tissue anchor, (B) is moveable through the pulley, and (C) has a length, measured between the first venous and the third atrial tissue anchors, of at least 30 mm. A size of a tricuspid orifice is reduced by tensioning the tether.

(22) PCT Filed: **Oct. 28, 2014**

(86) PCT No.: **PCT/IB2014/002351**

§ 371 (c)(1),

(2) Date: **Apr. 21, 2016**

Related U.S. Application Data

(60) Provisional application No. 61/897,509, filed on Oct. 30, 2013.

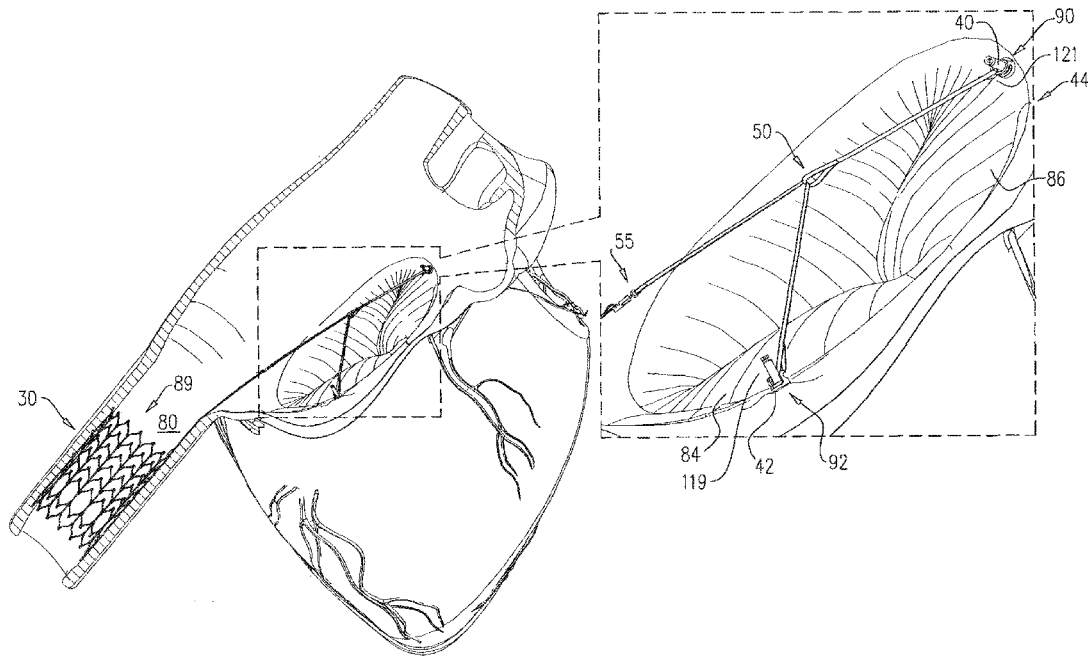
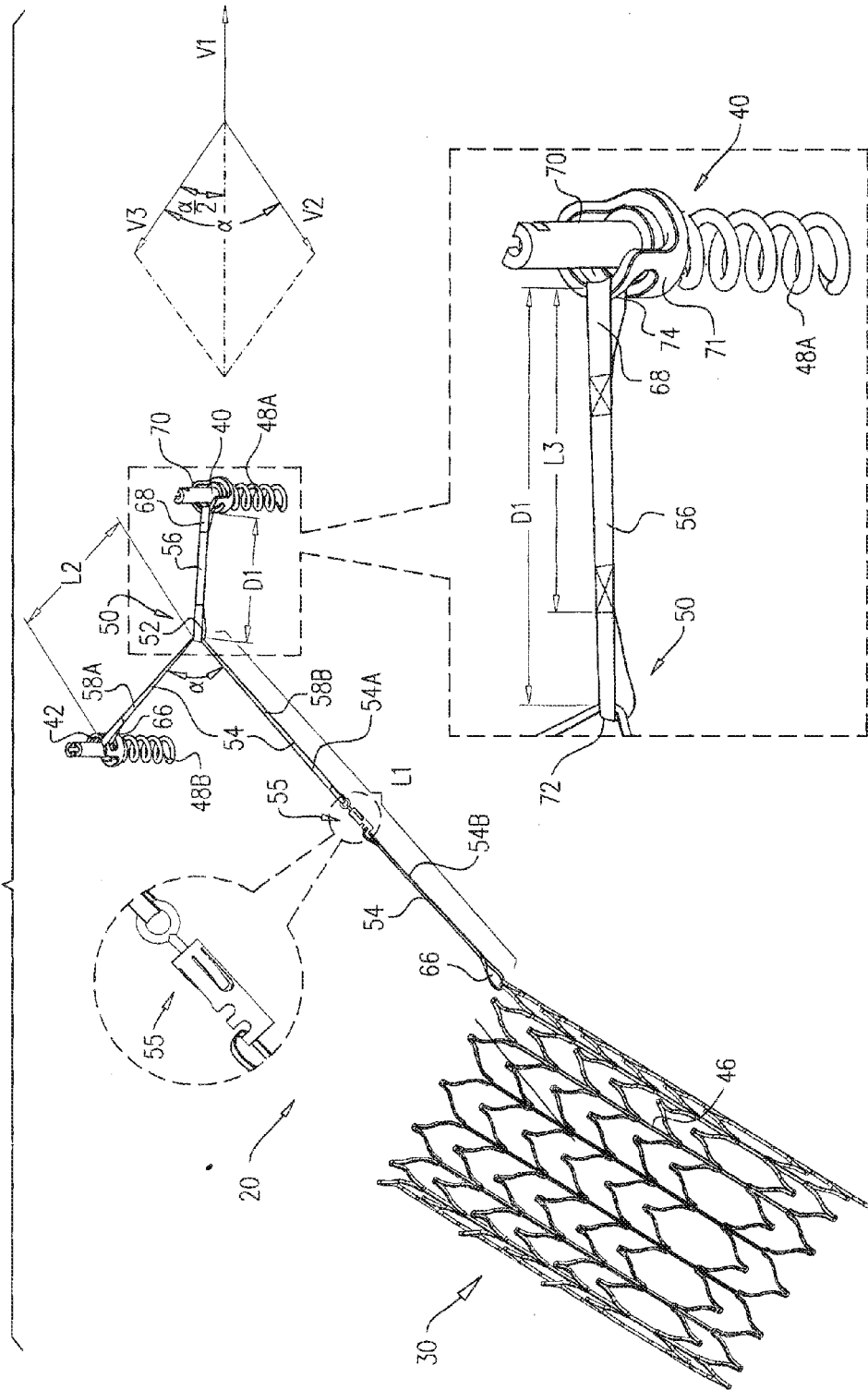


FIG. 1



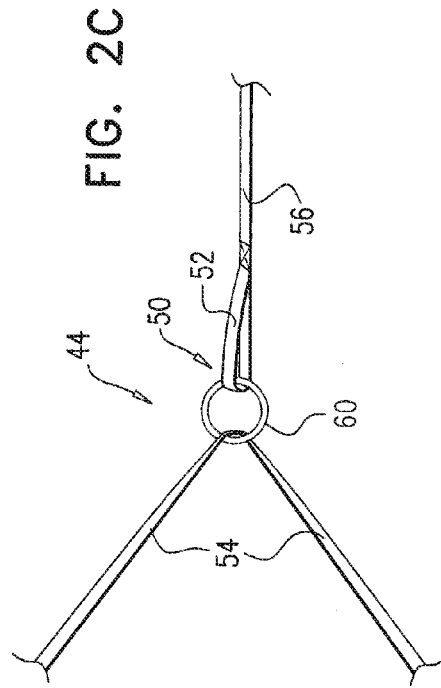
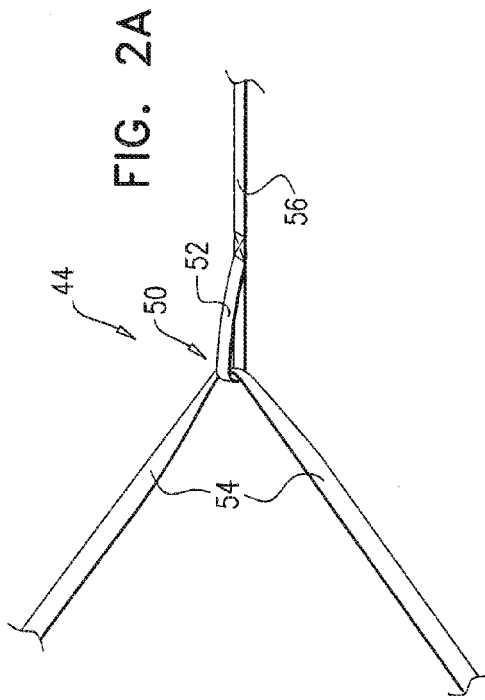
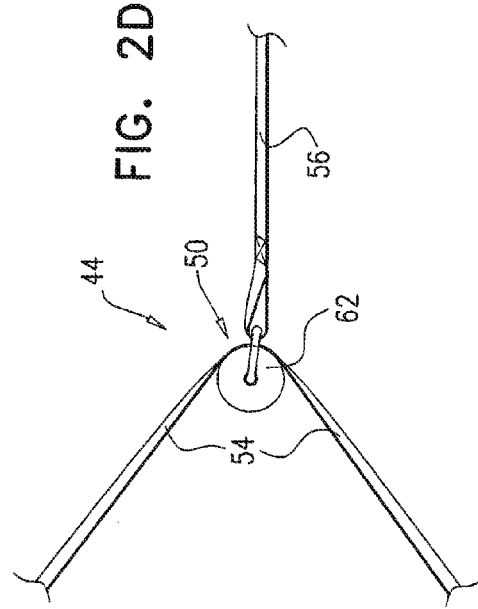
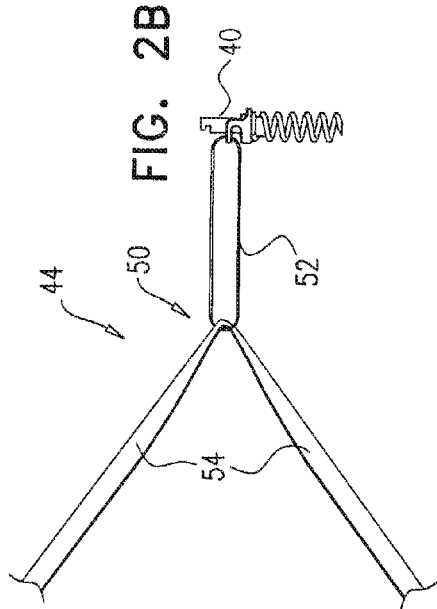


FIG. 3C

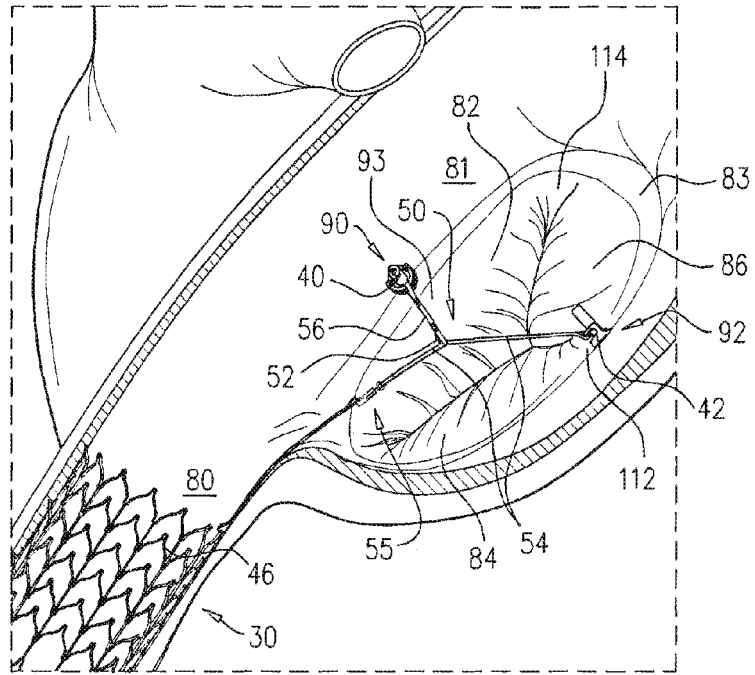
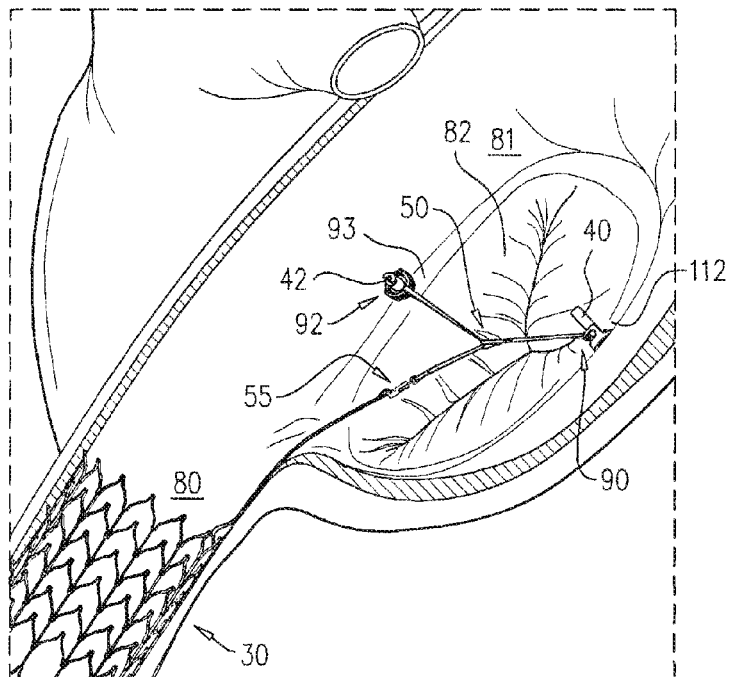
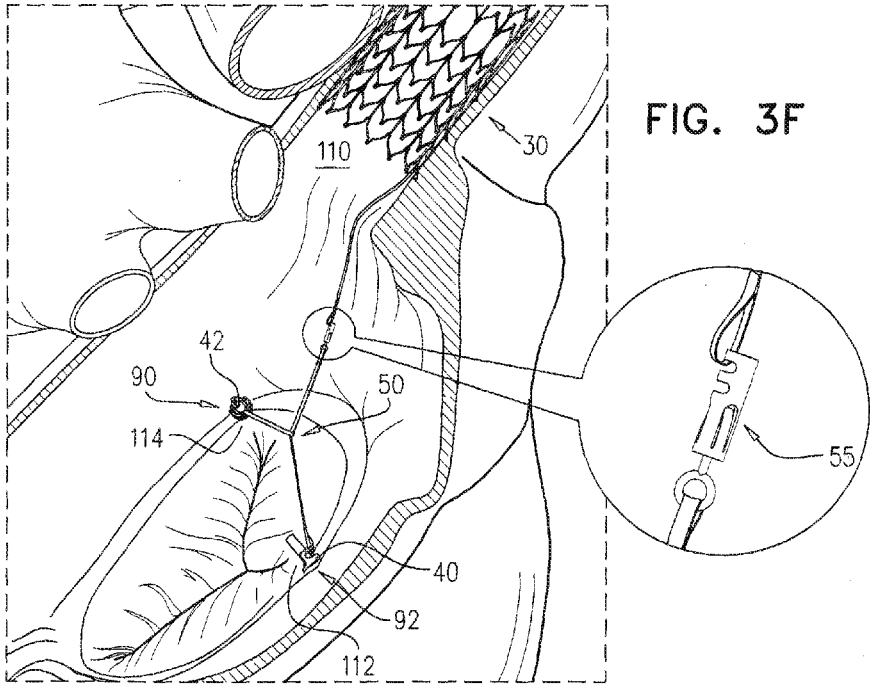
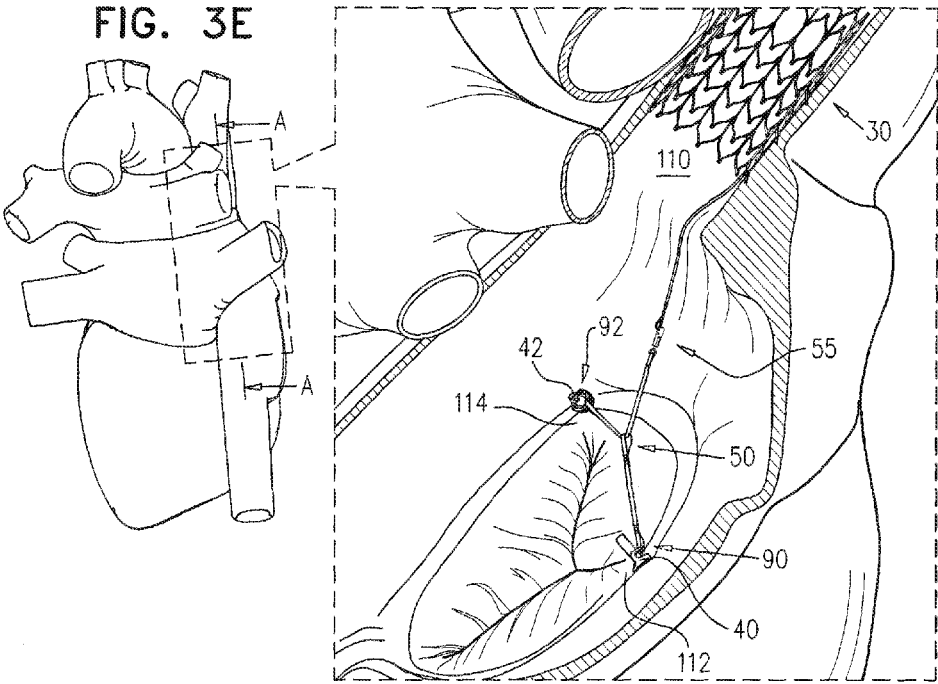
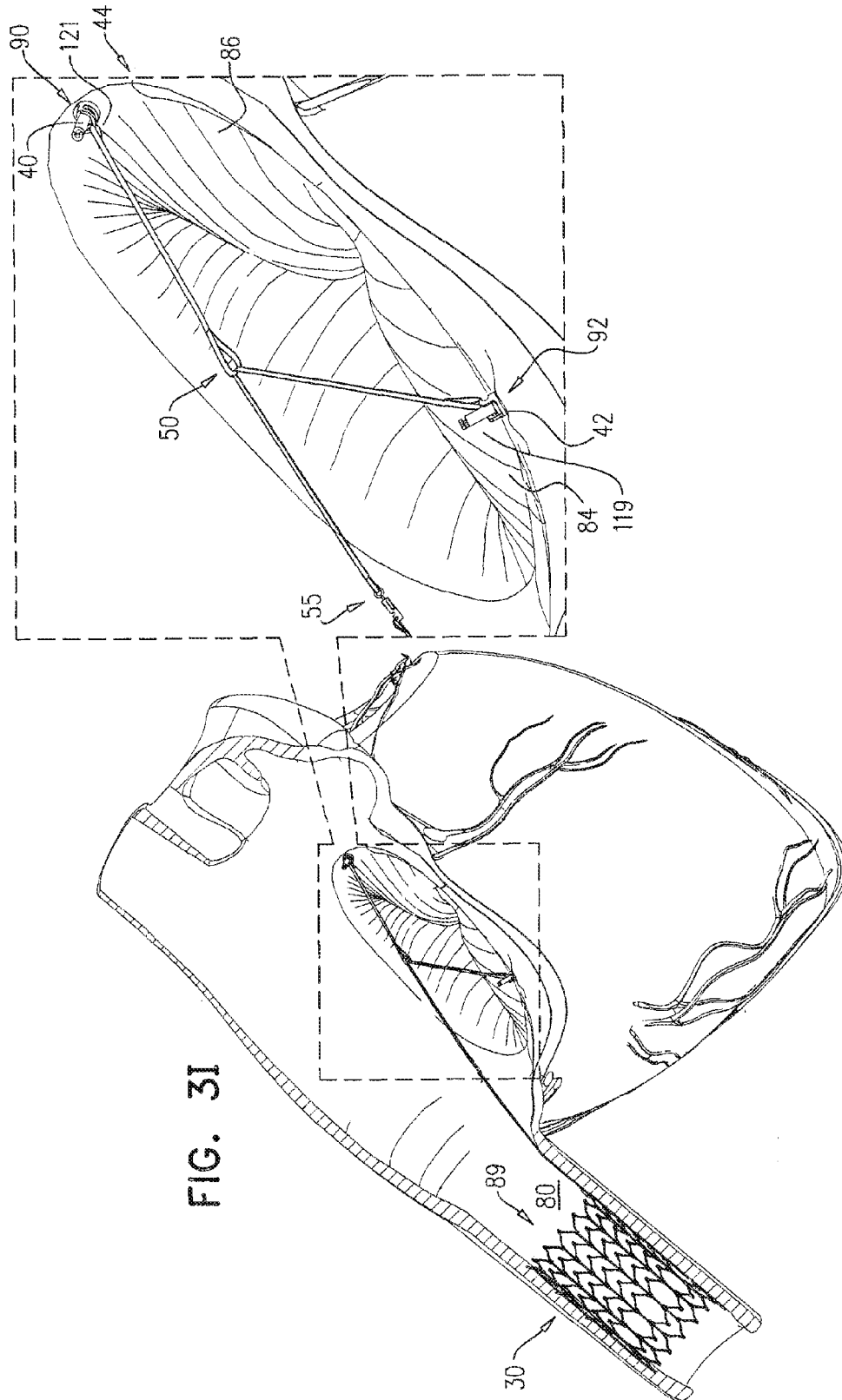
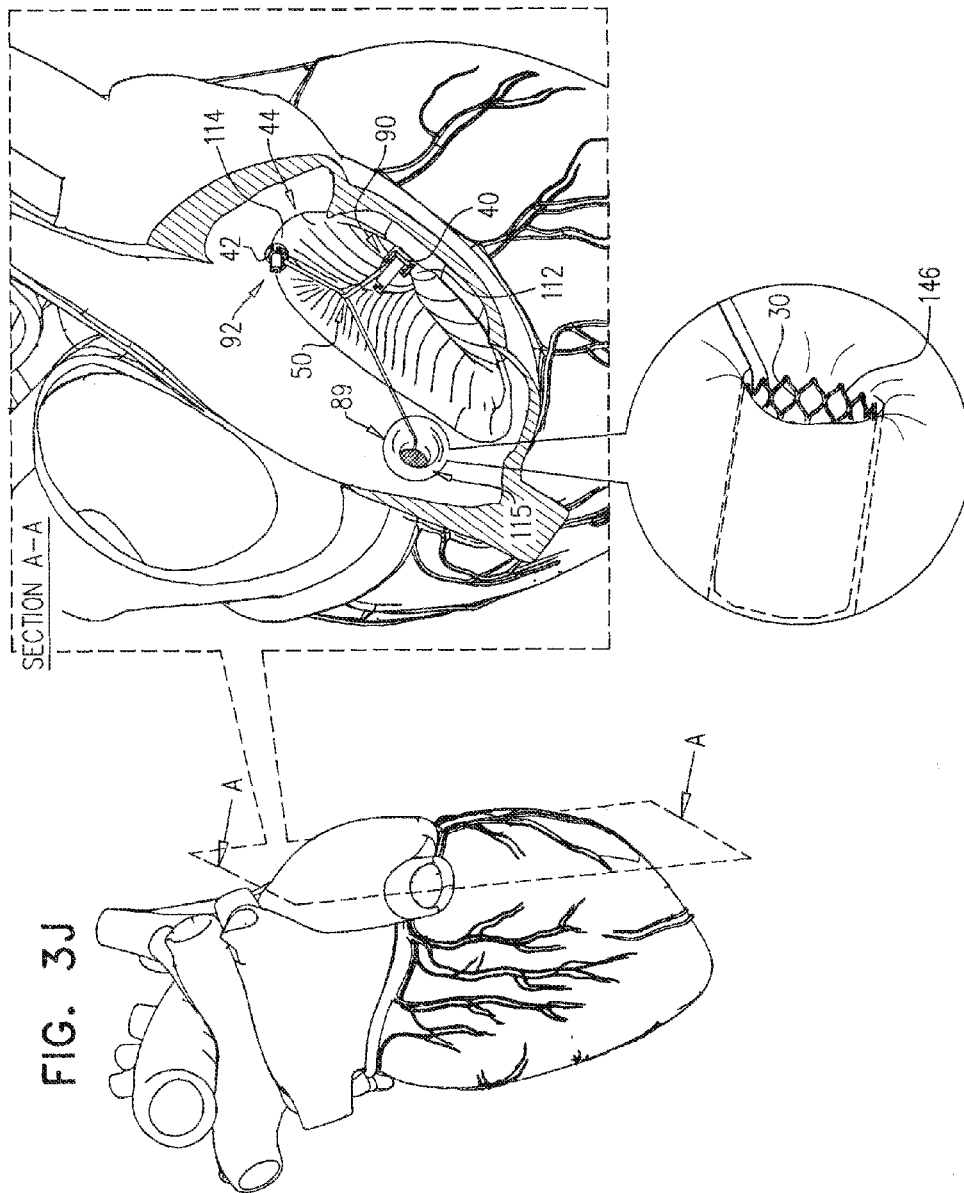


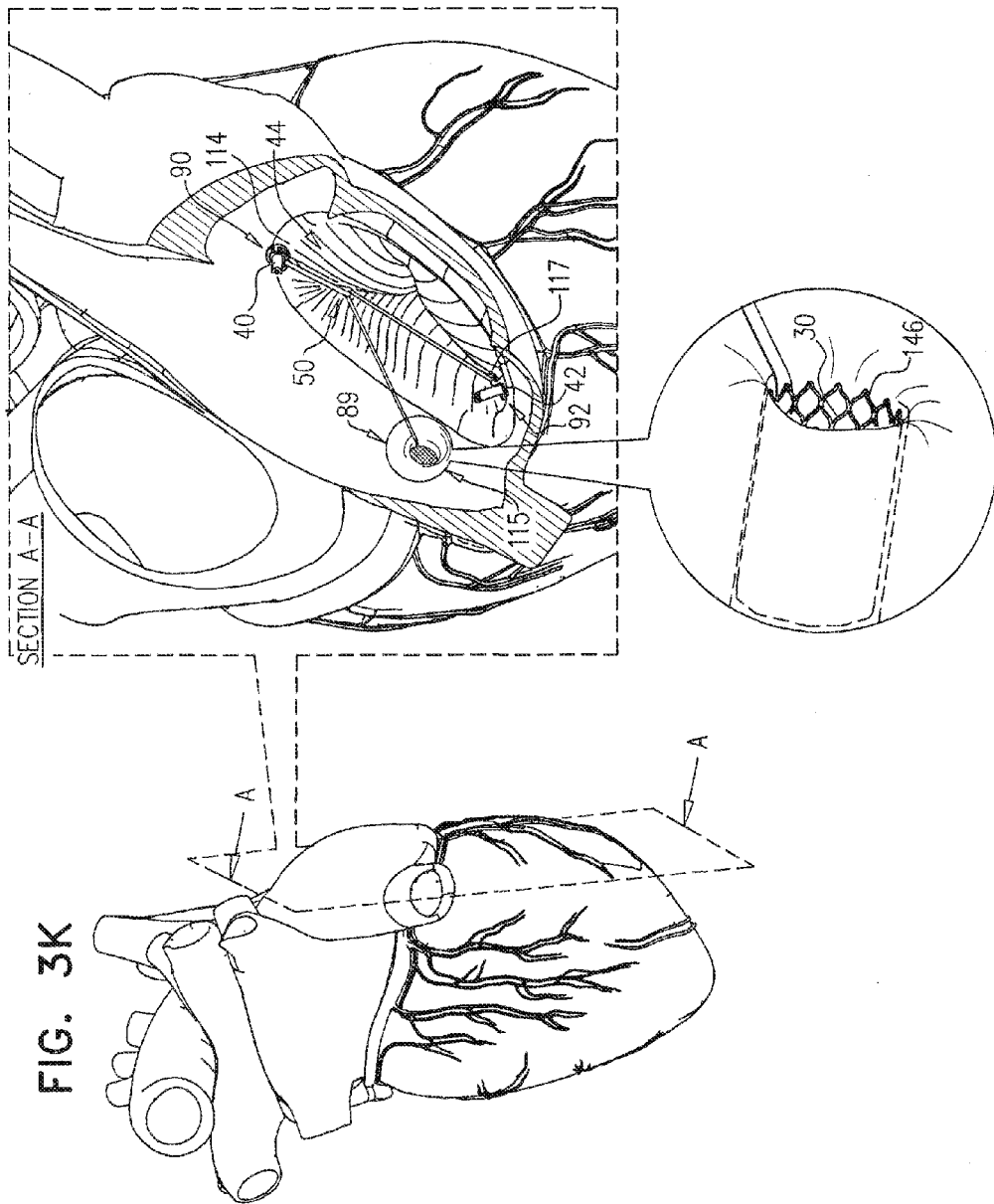
FIG. 3D

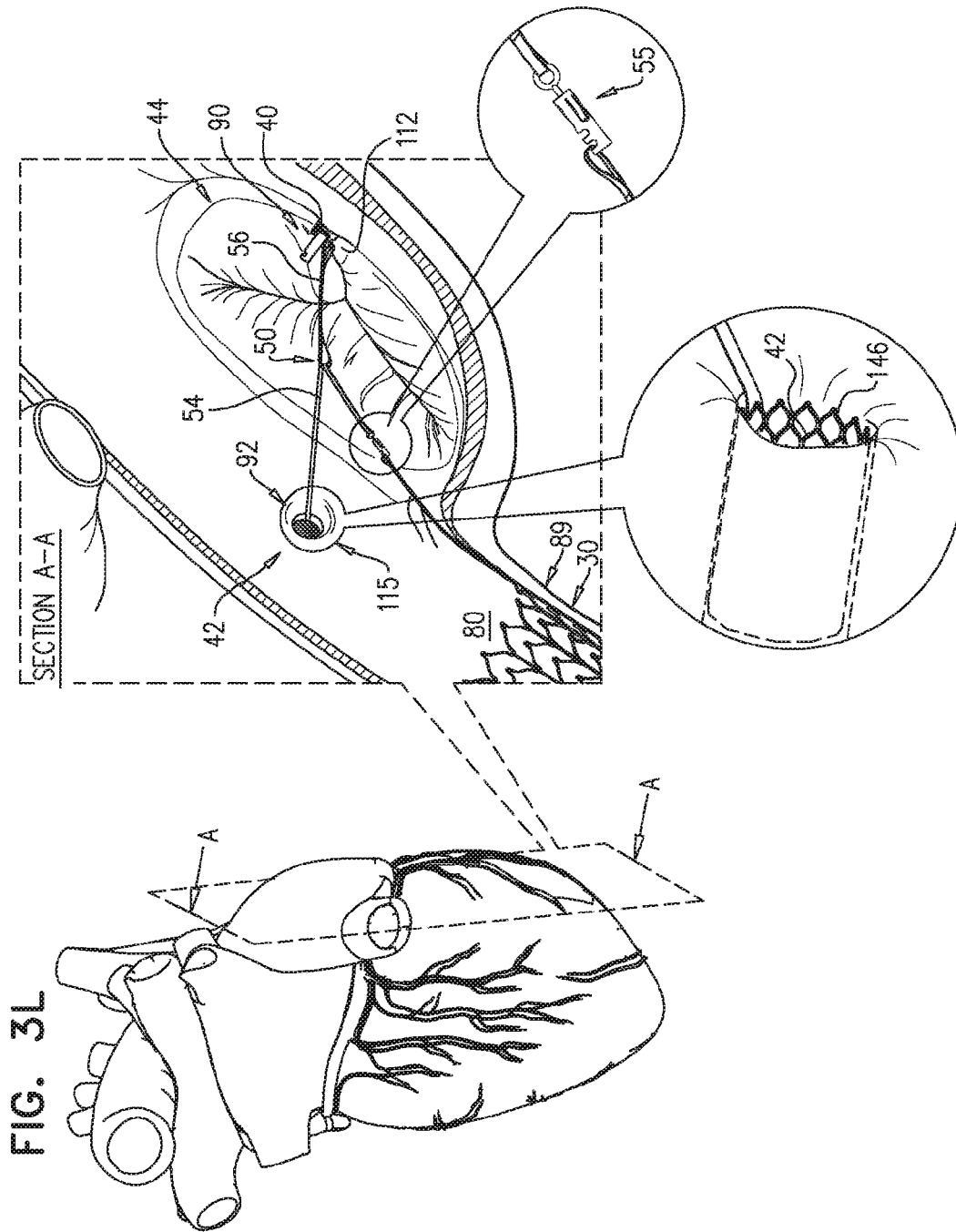


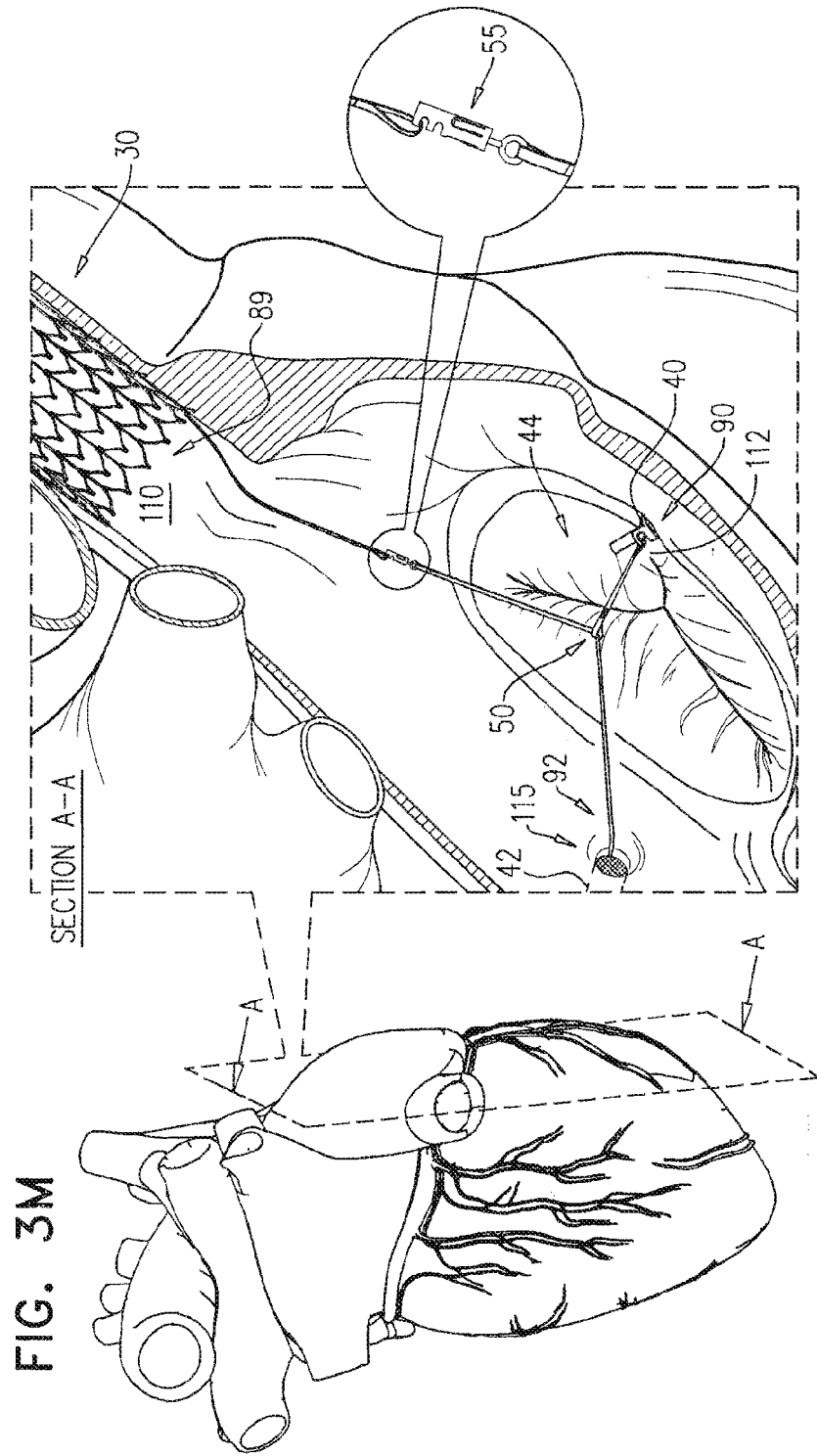


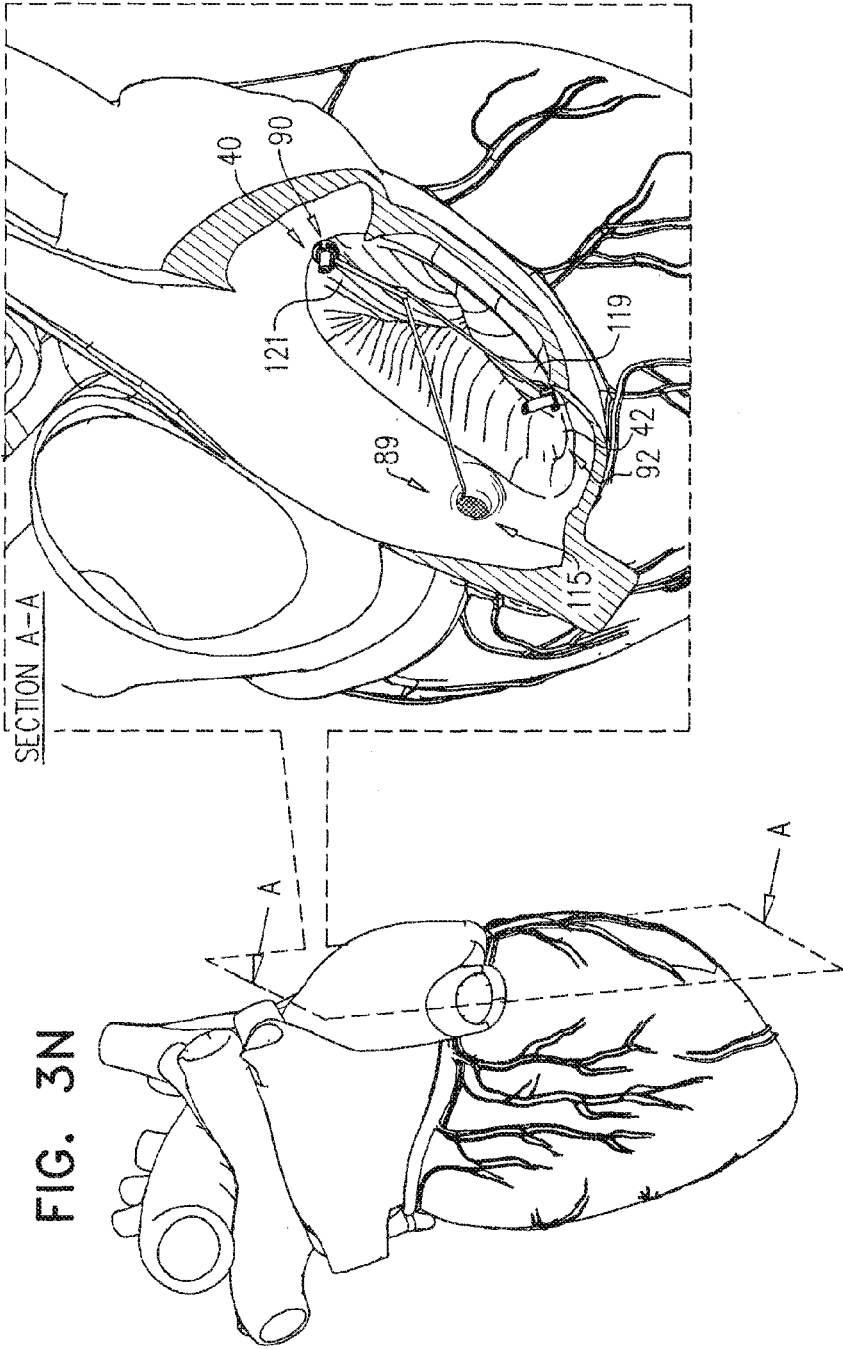


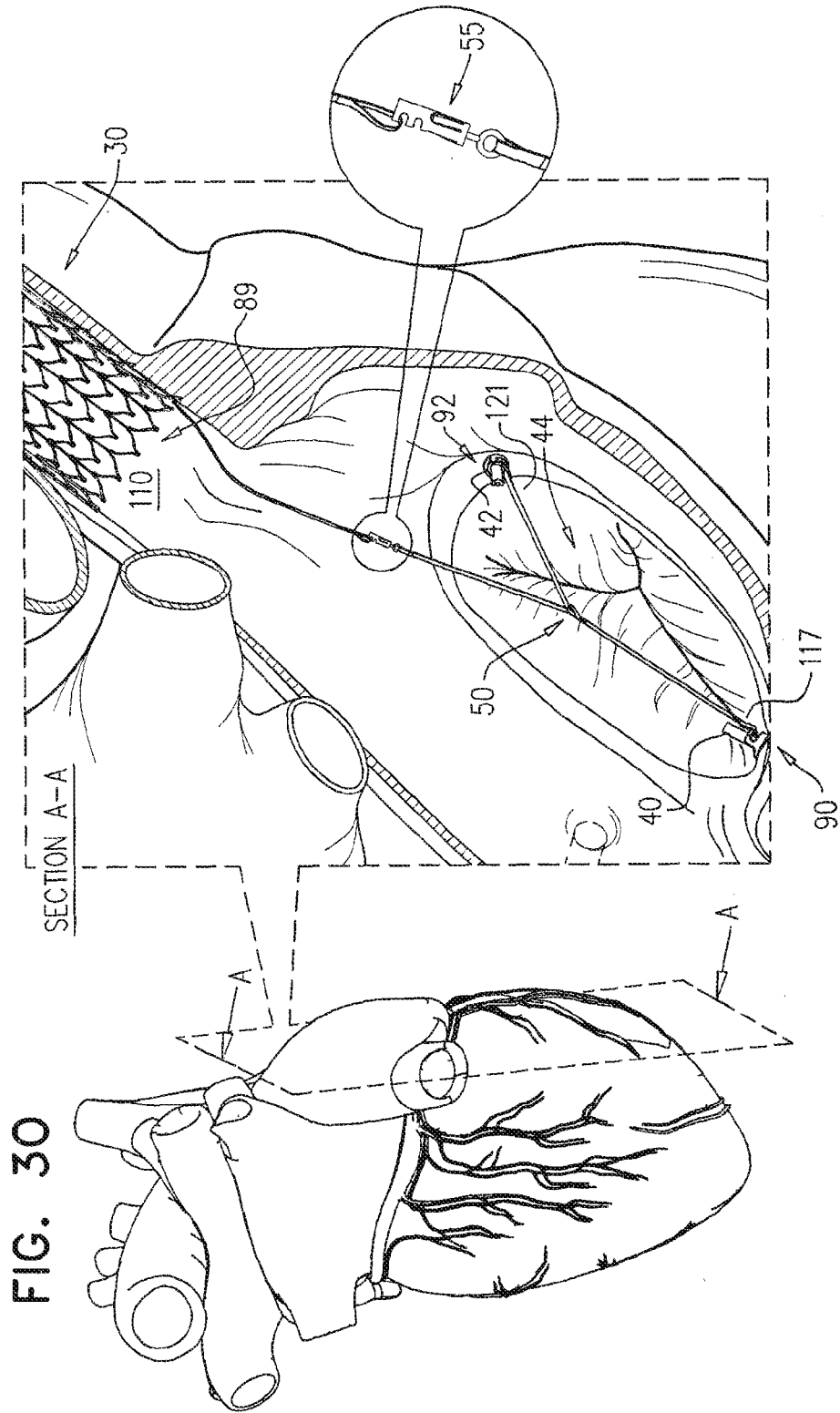












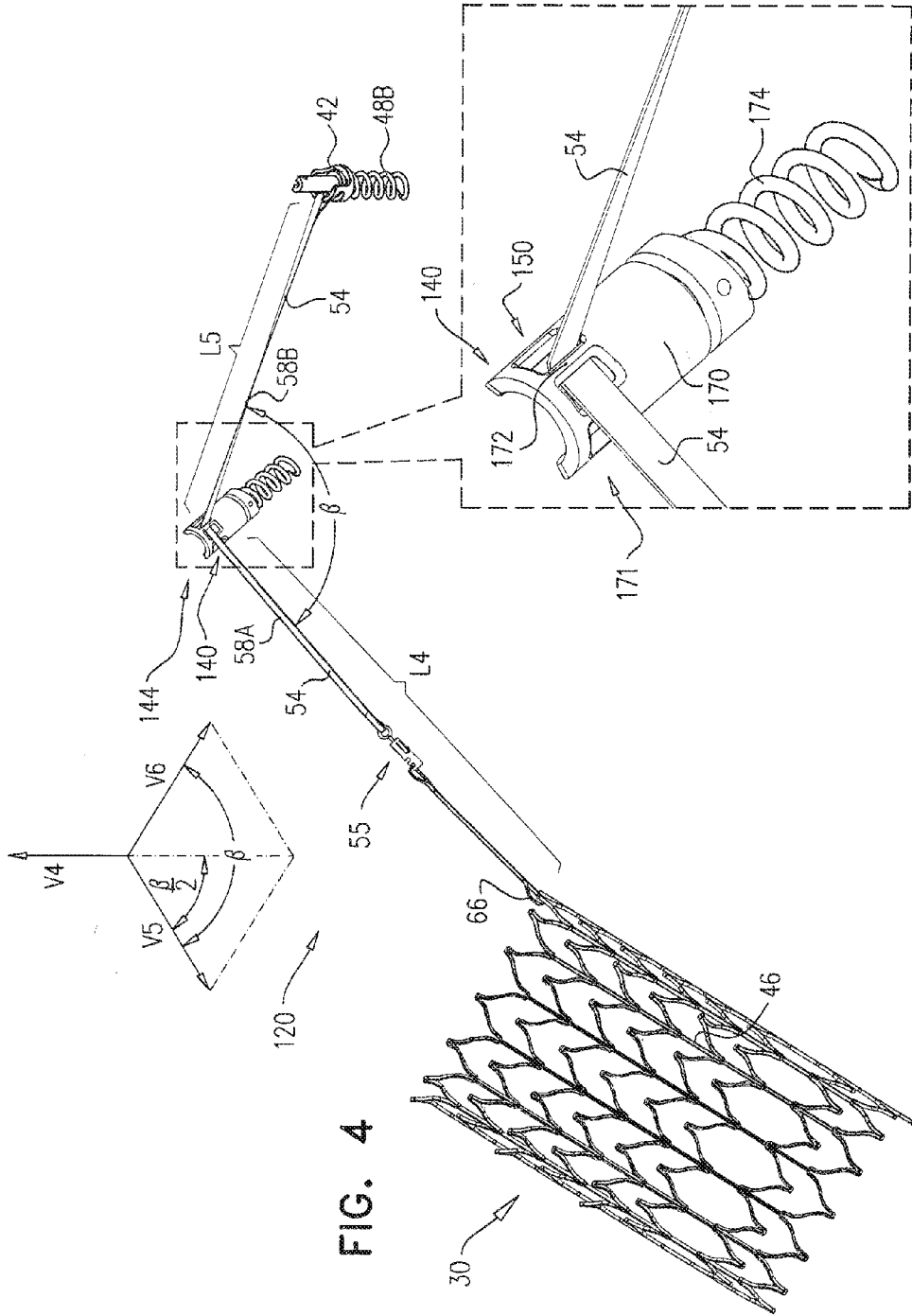
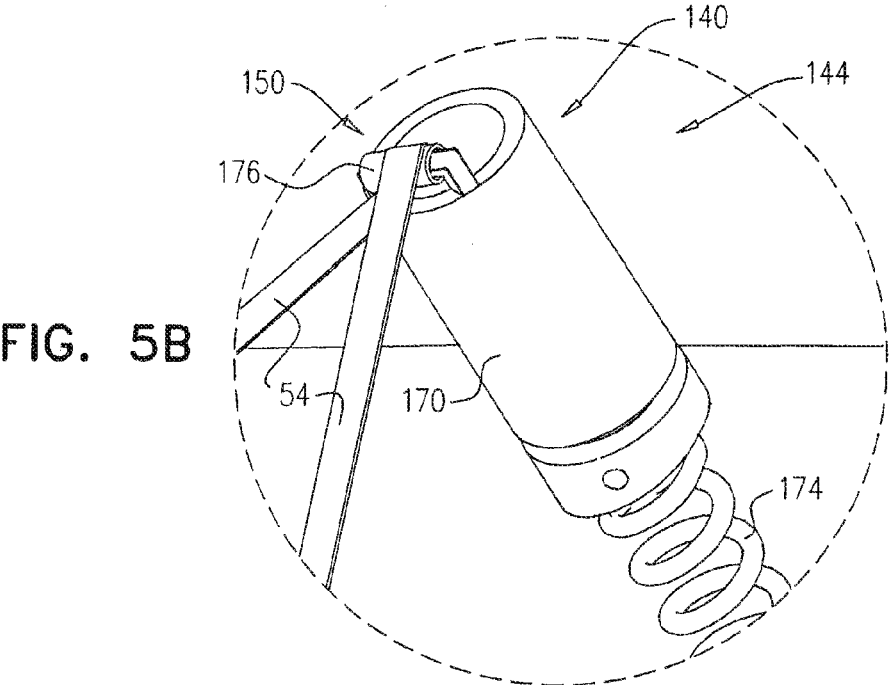
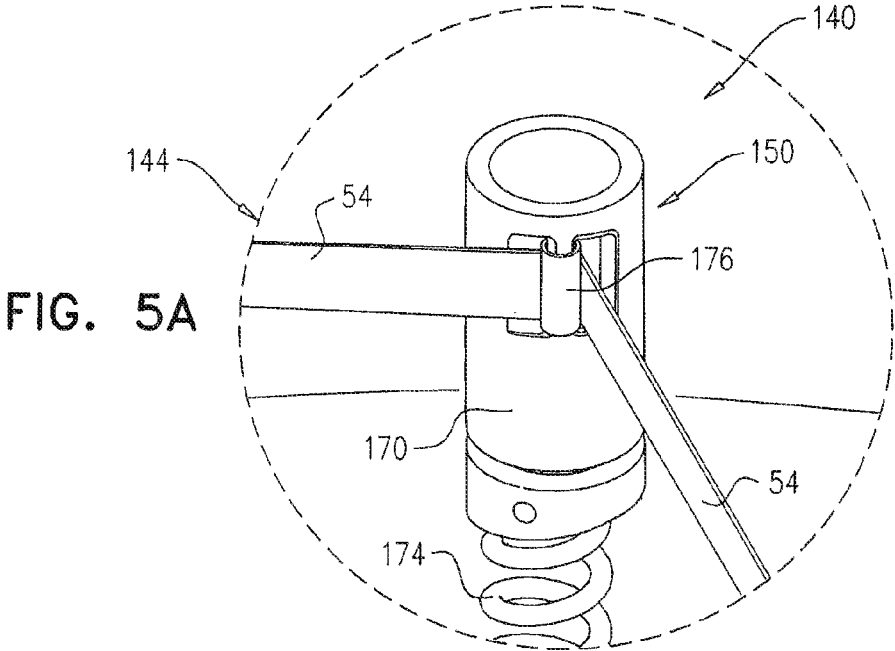


FIG. 4



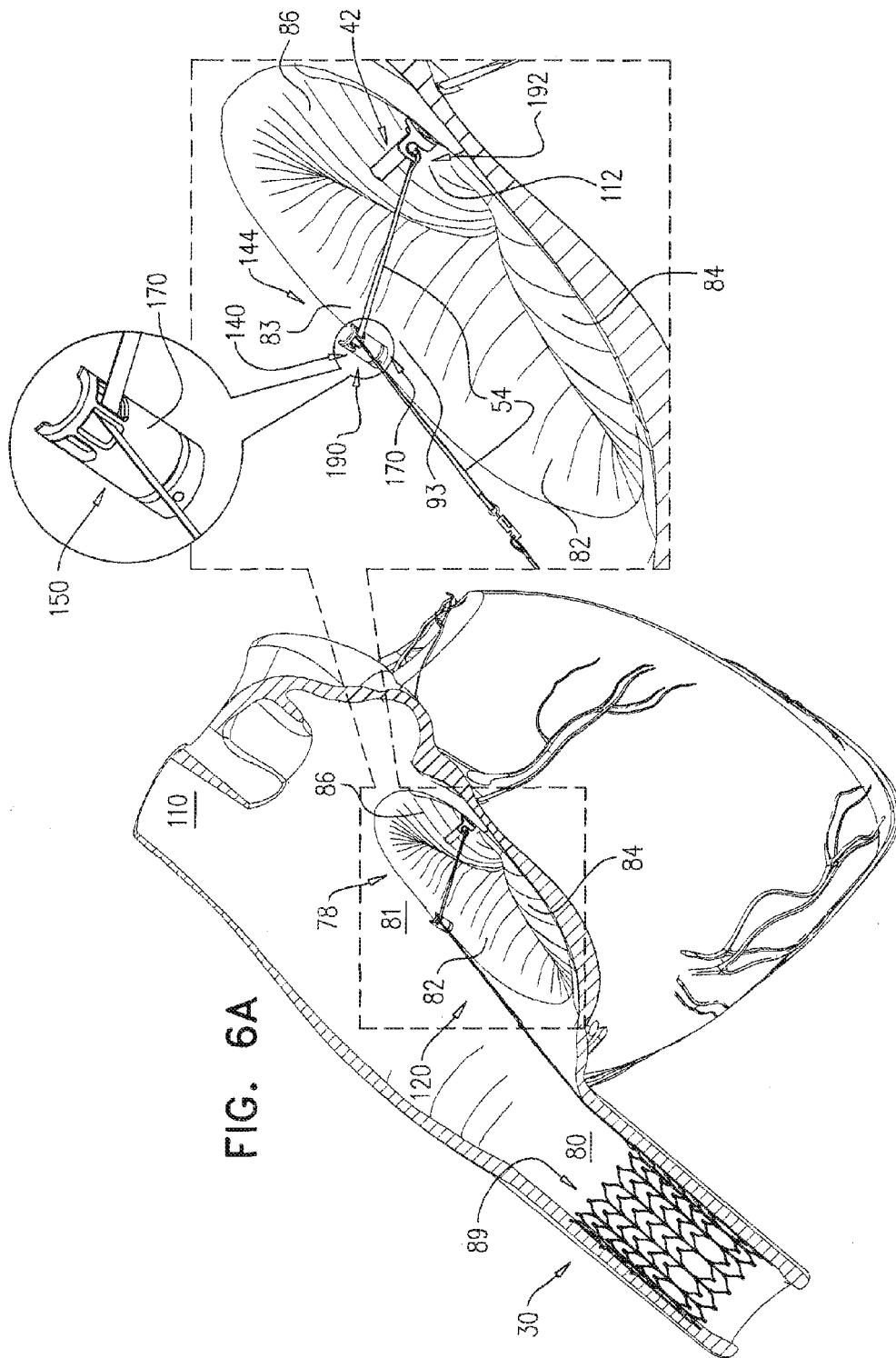


FIG. 6C

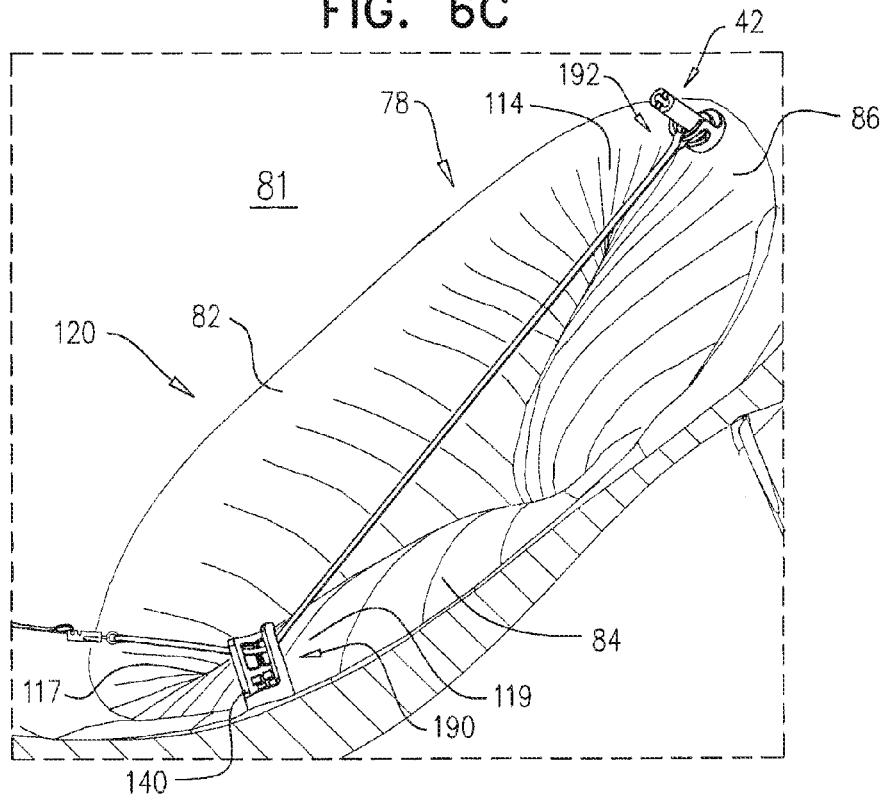
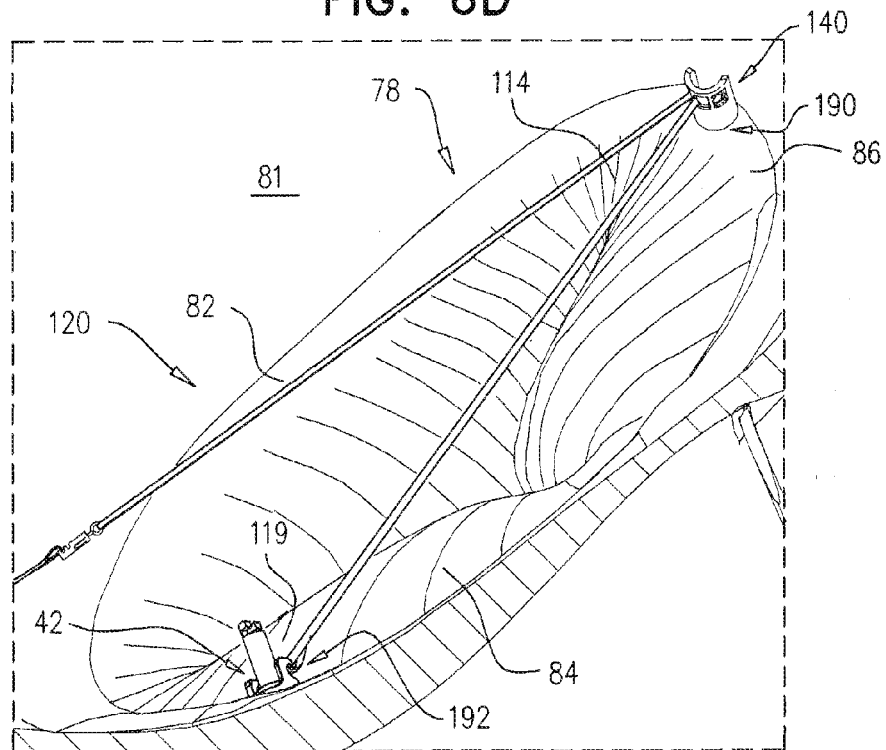
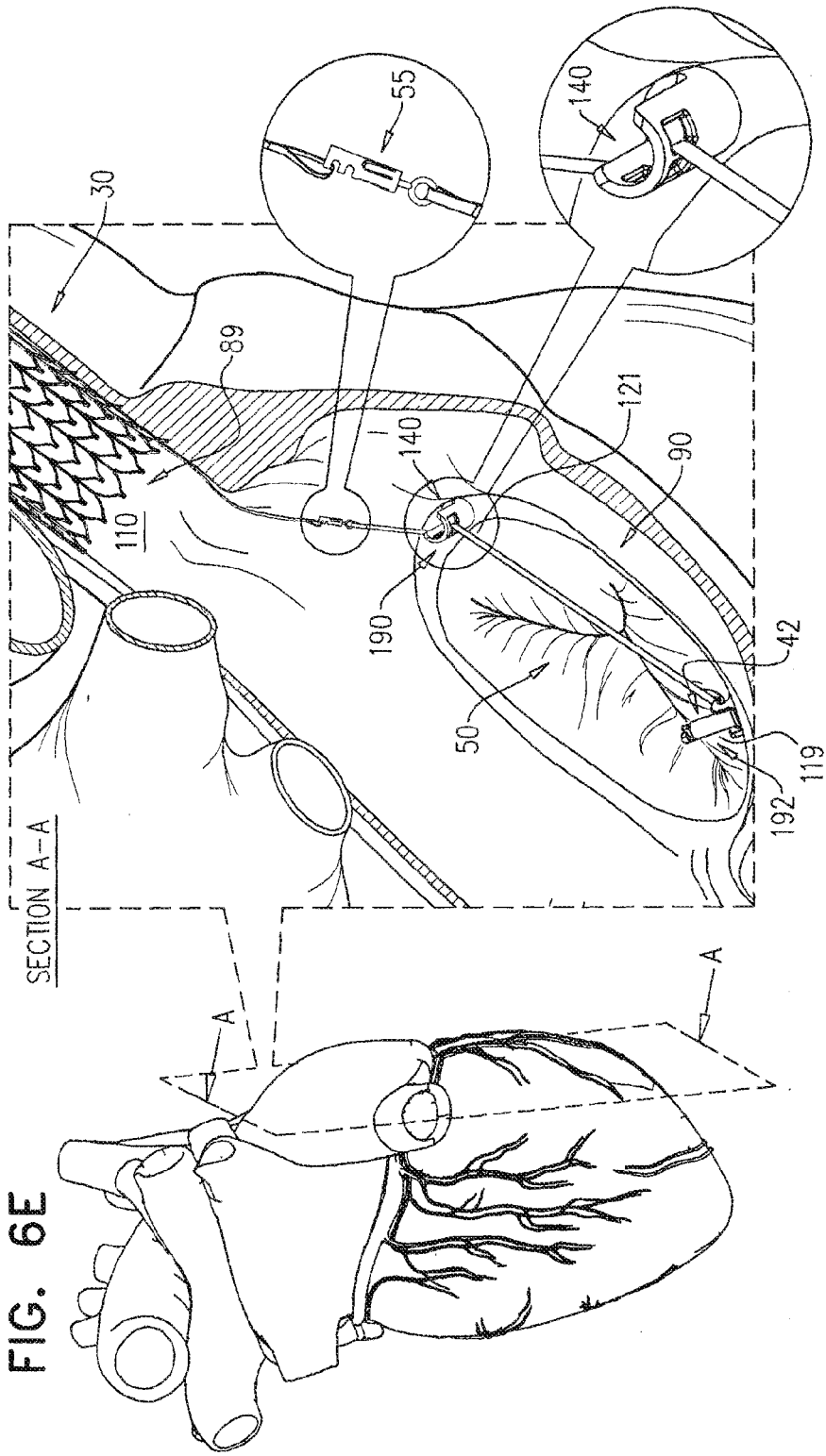
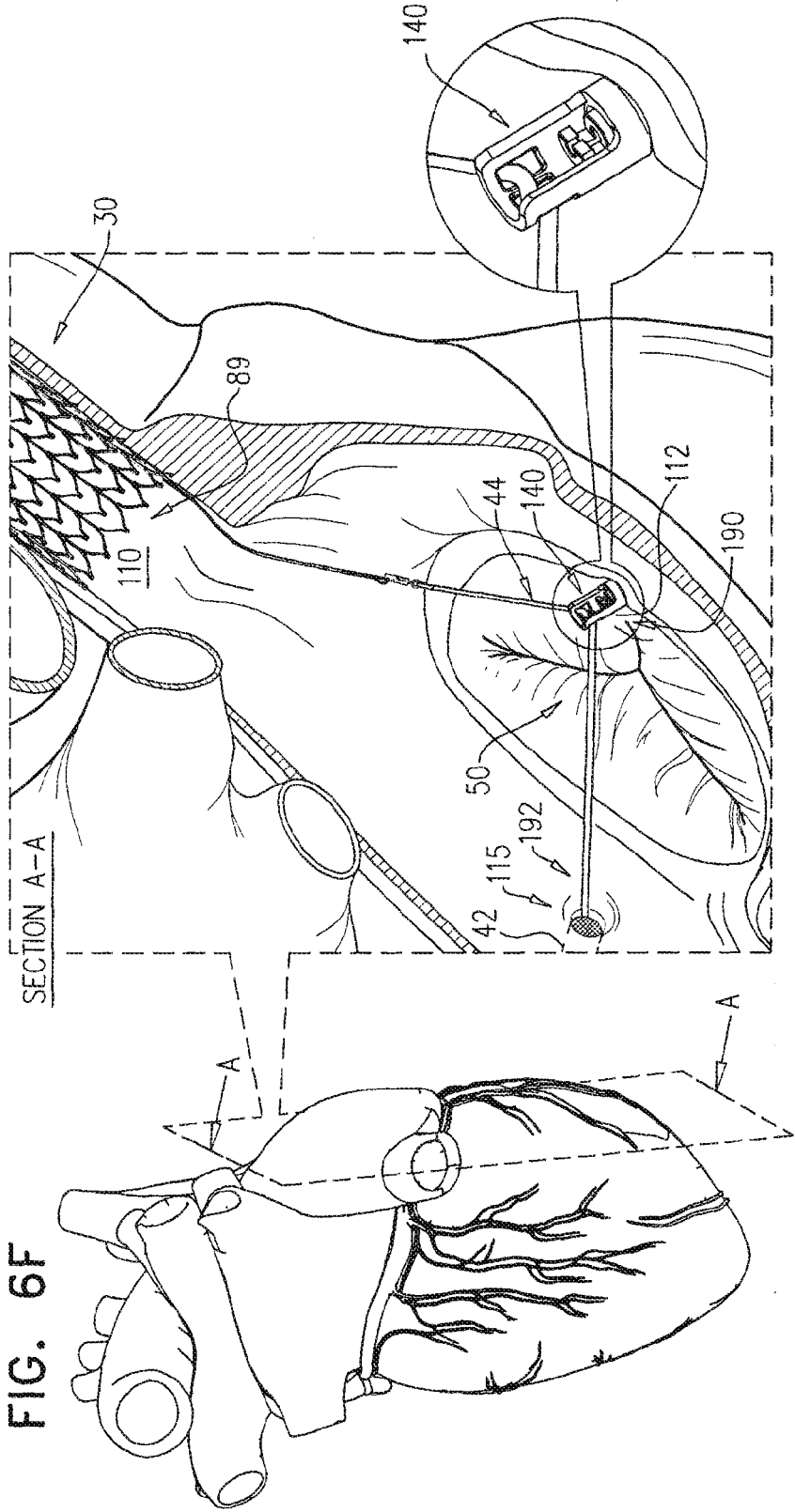
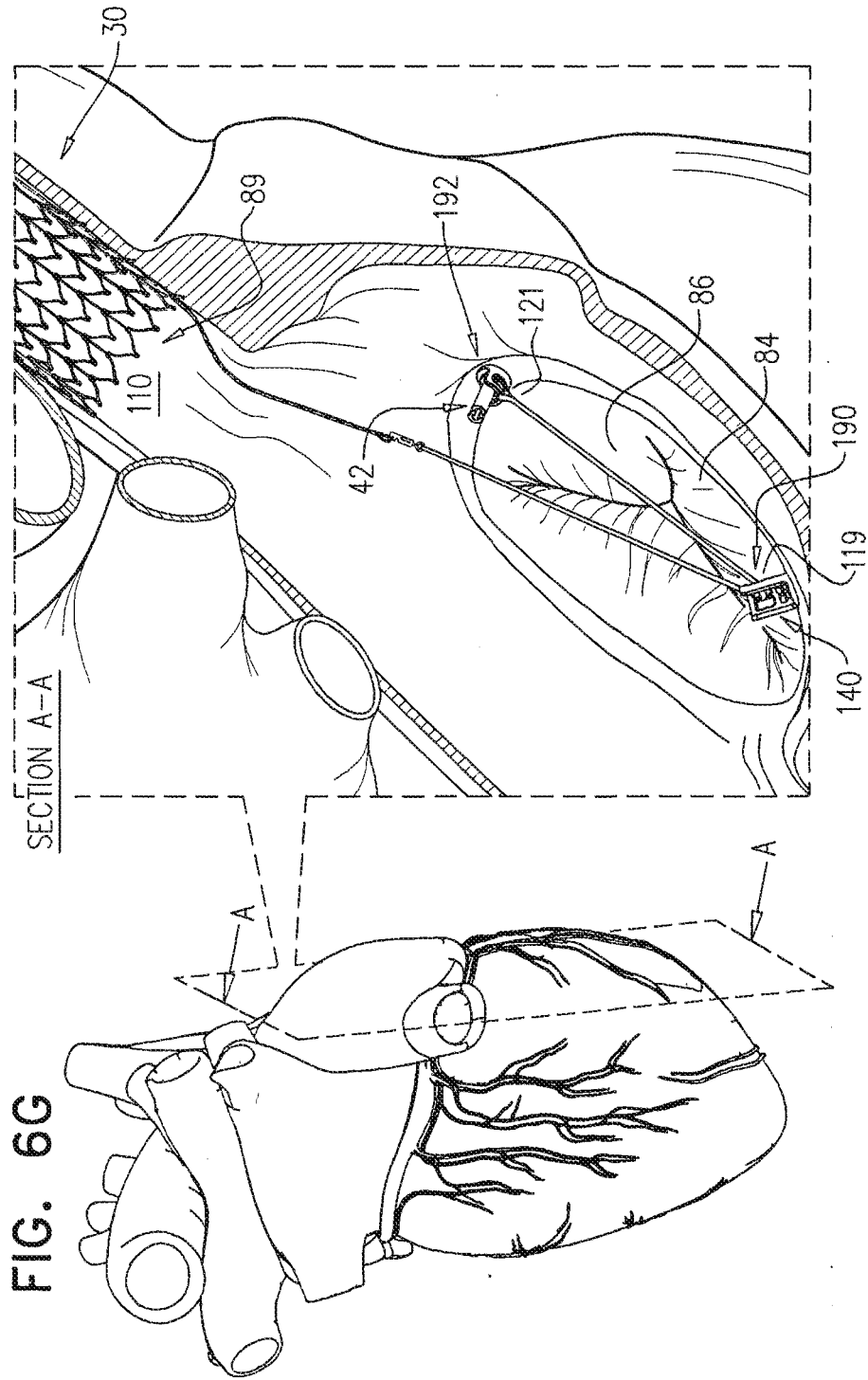


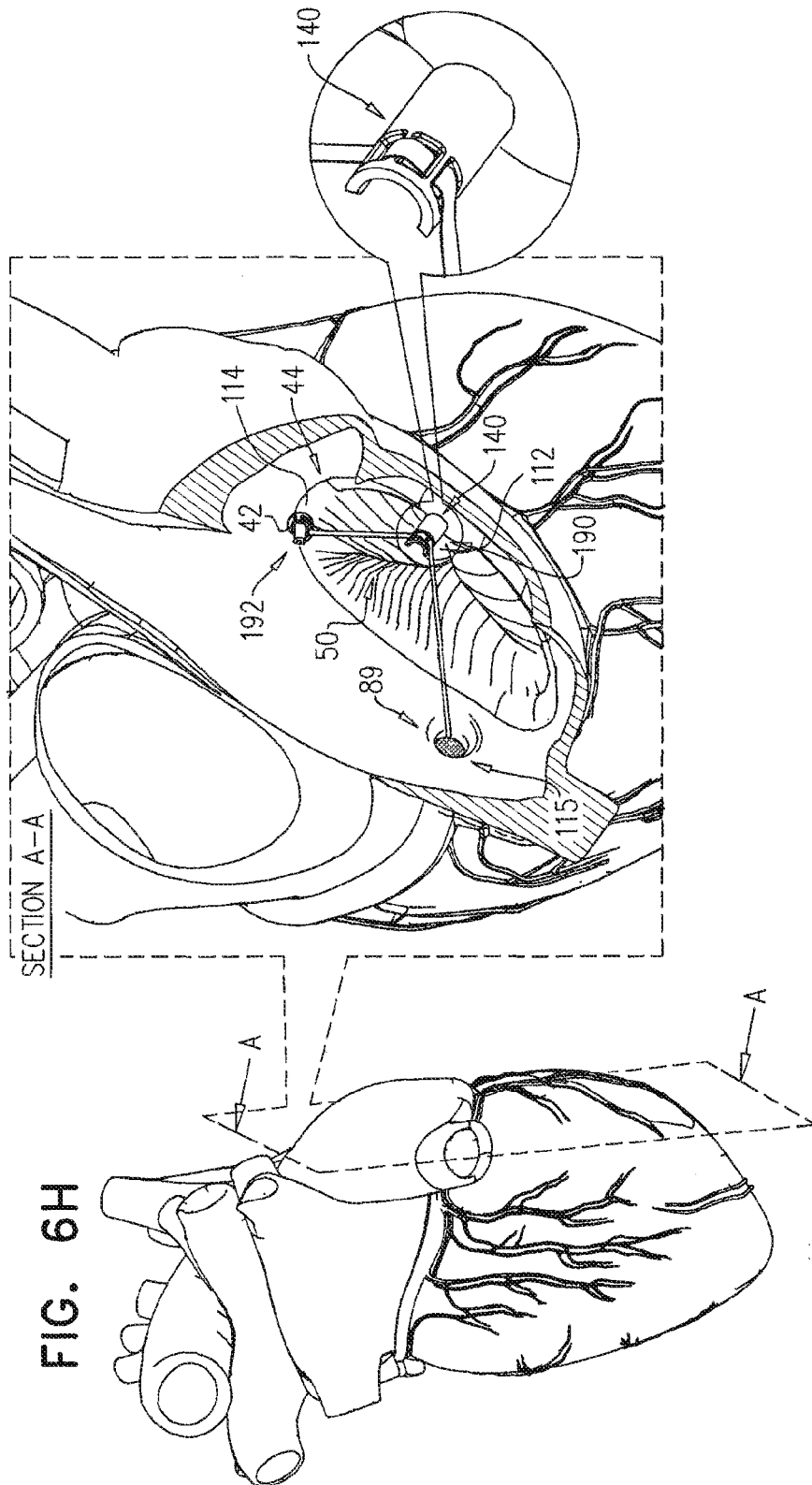
FIG. 6D

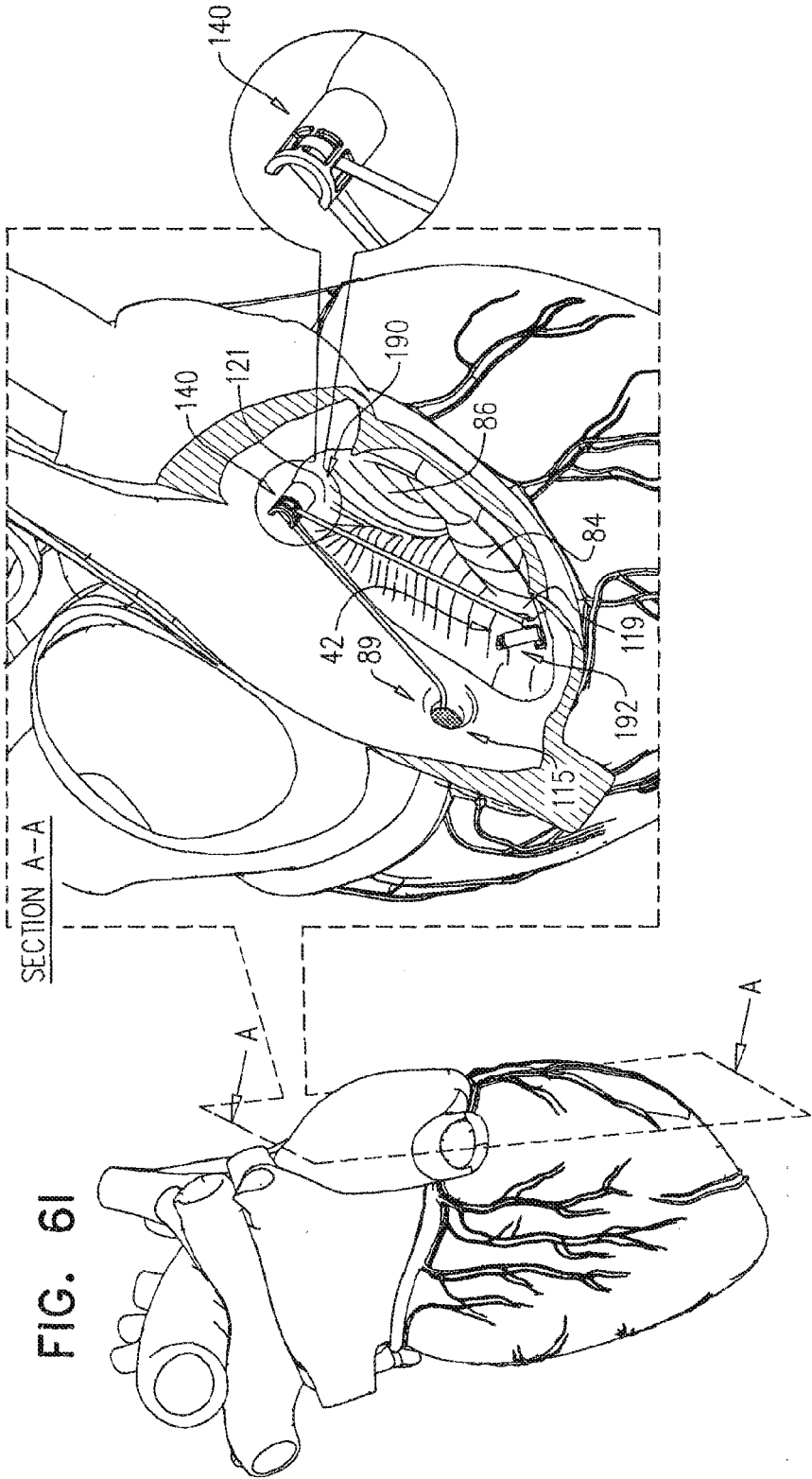


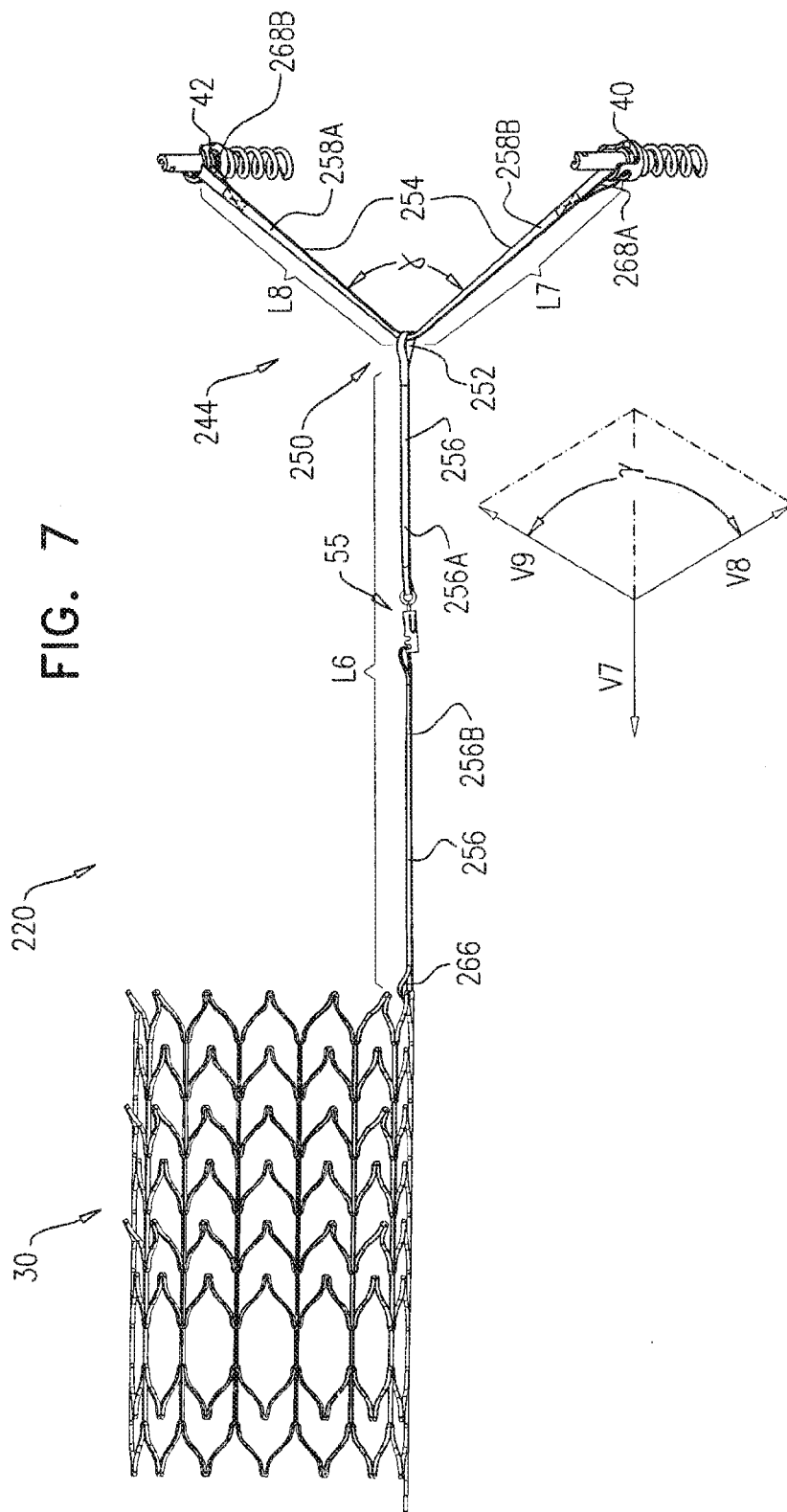


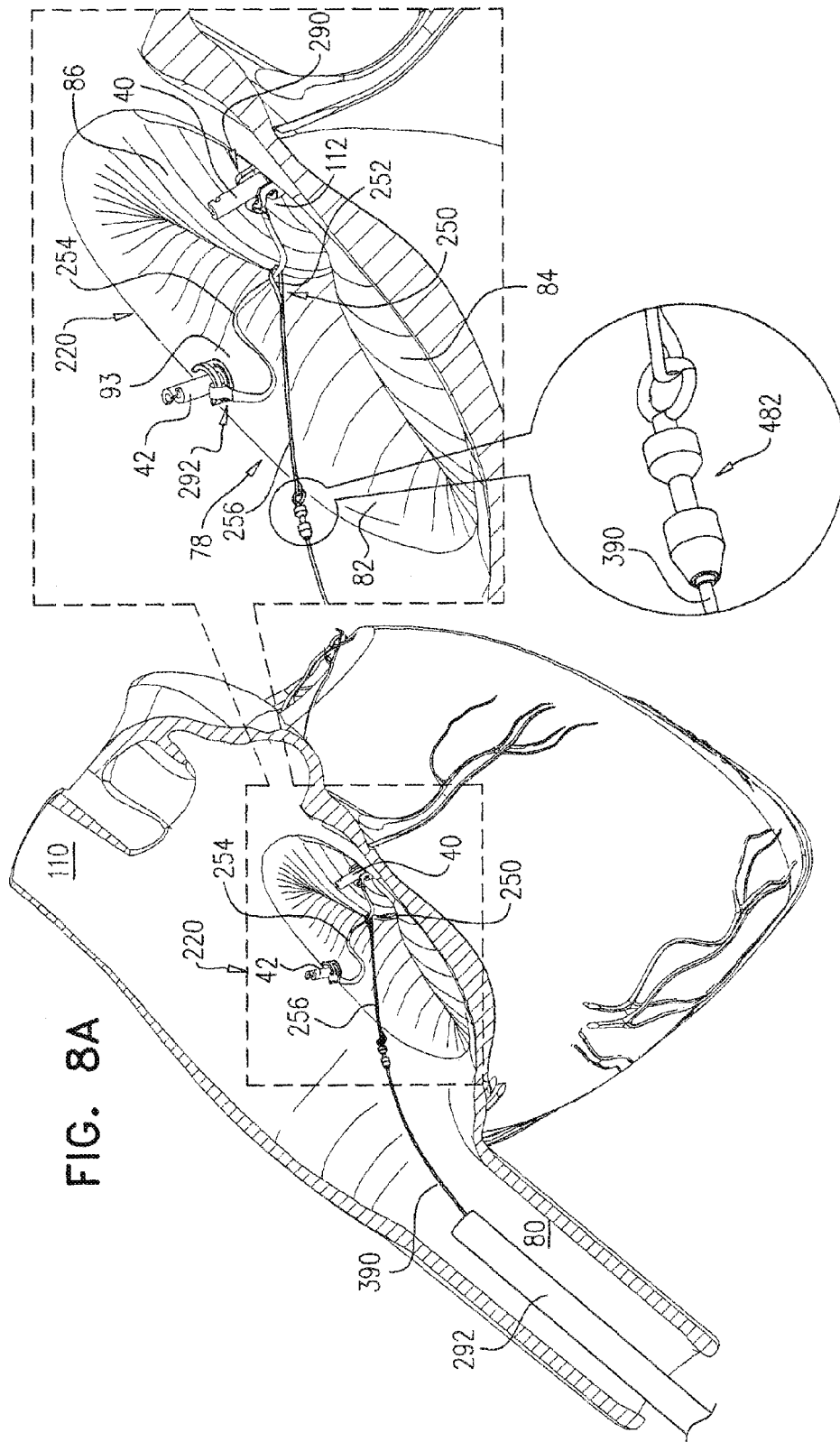


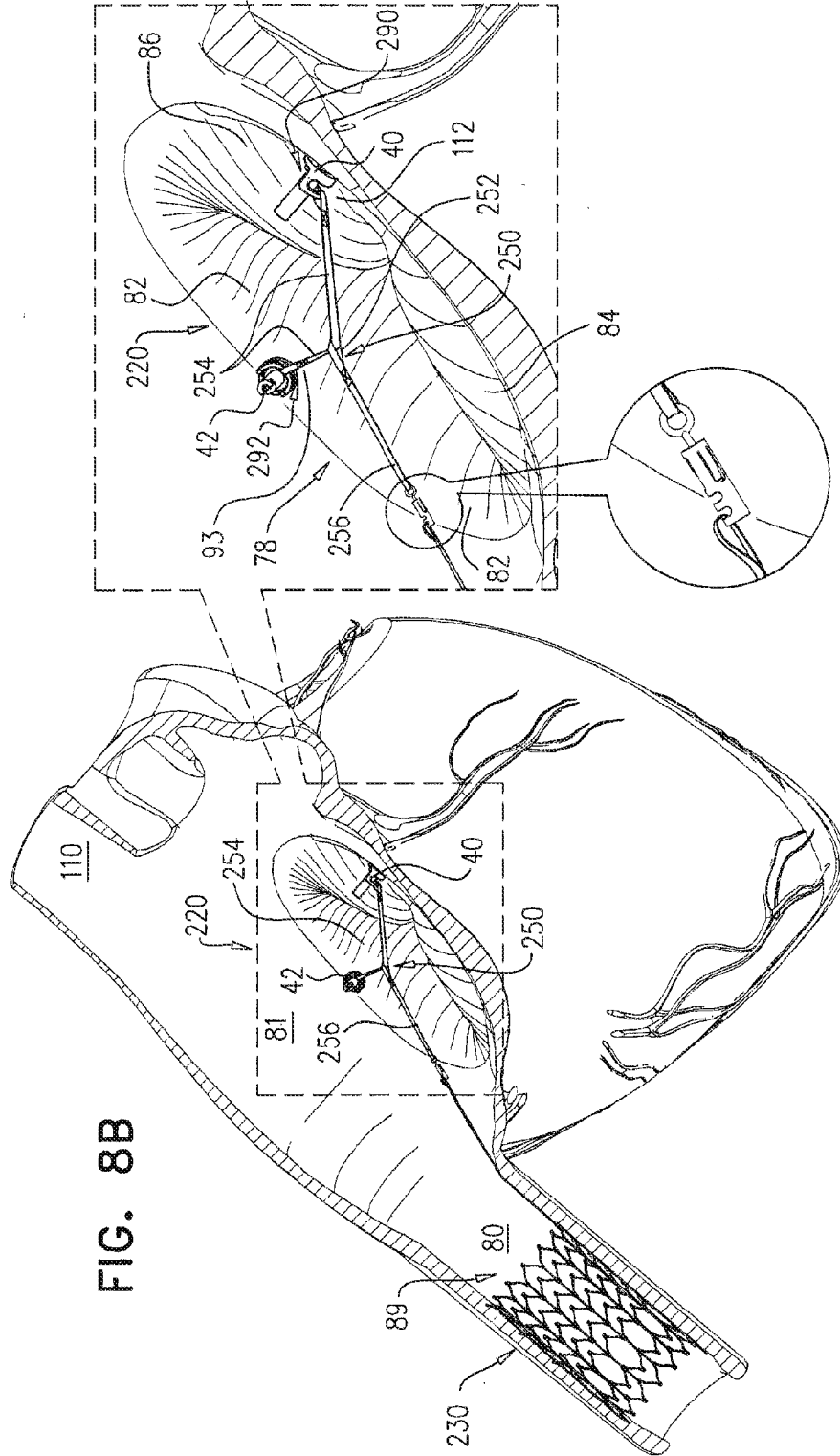


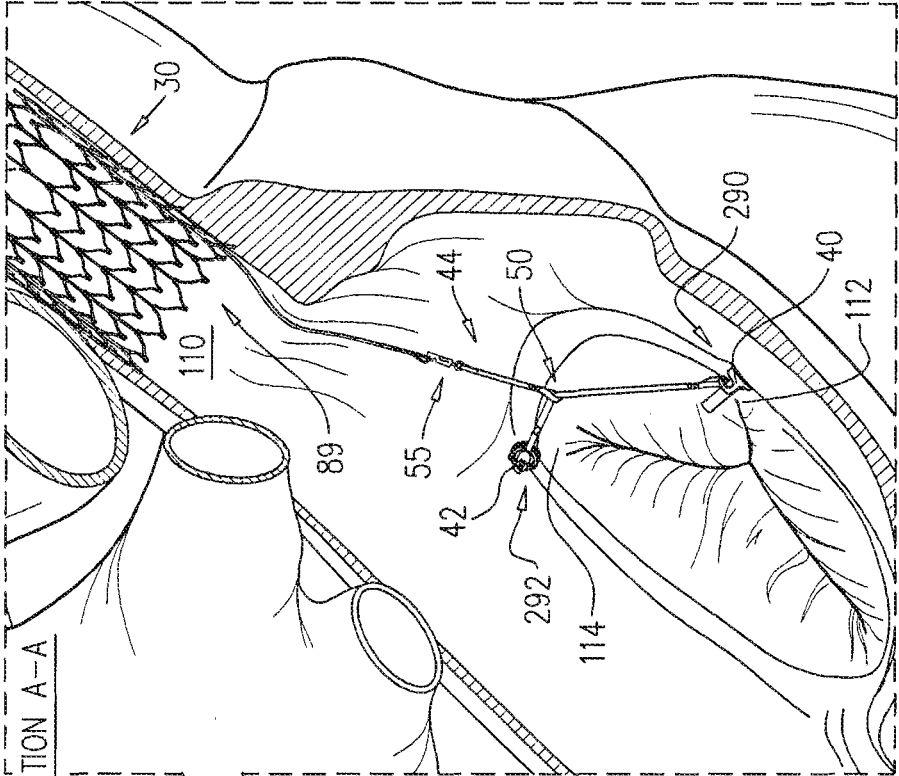






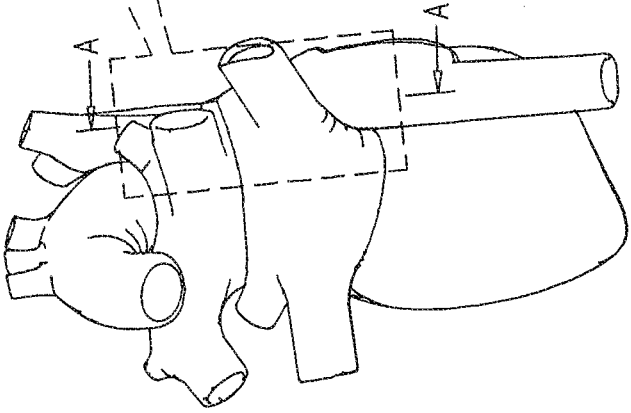






SECTION A-A

FIG. 8C



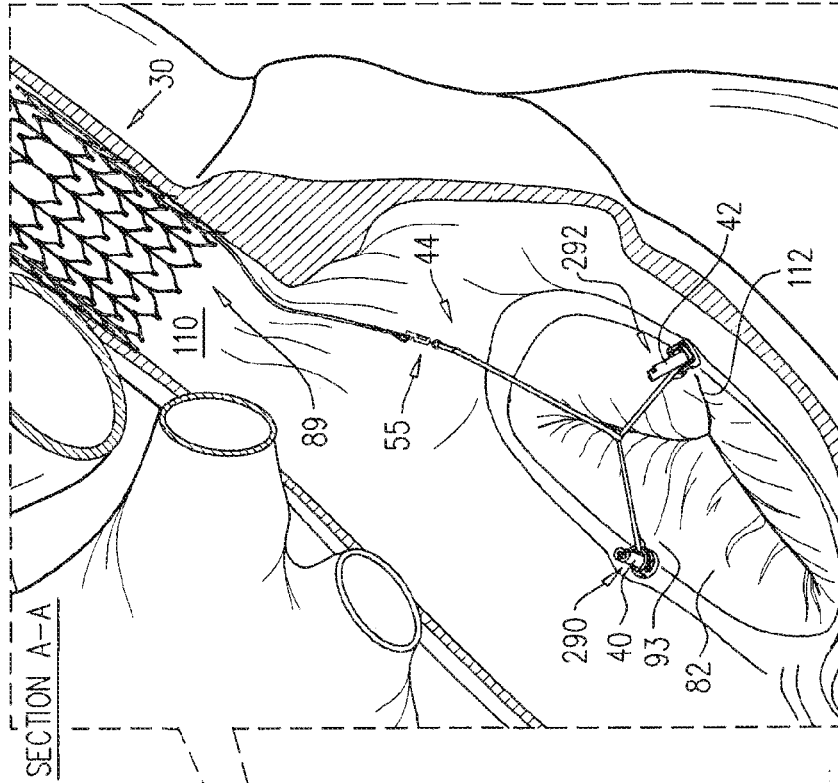
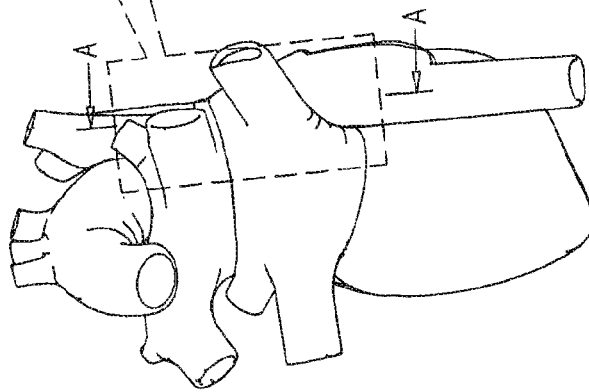
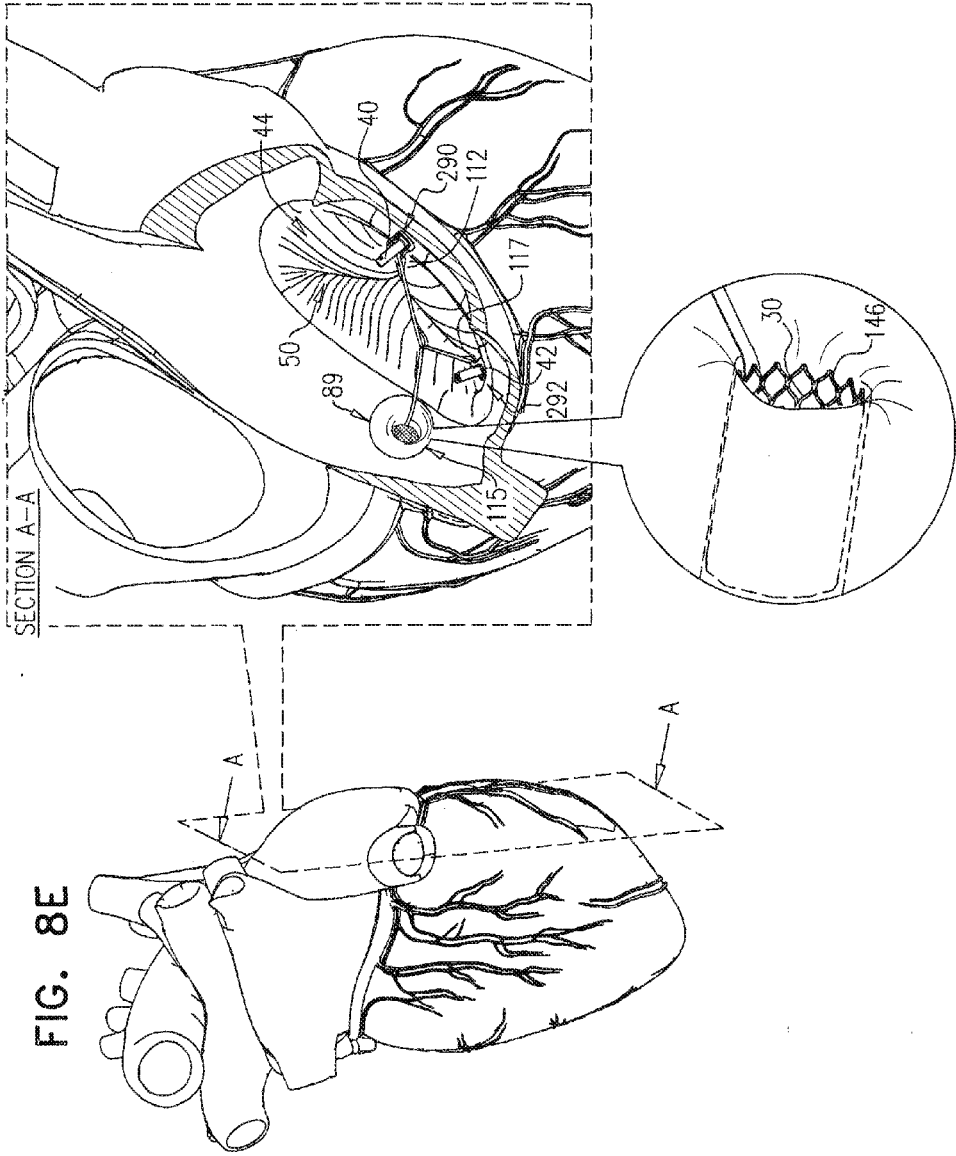
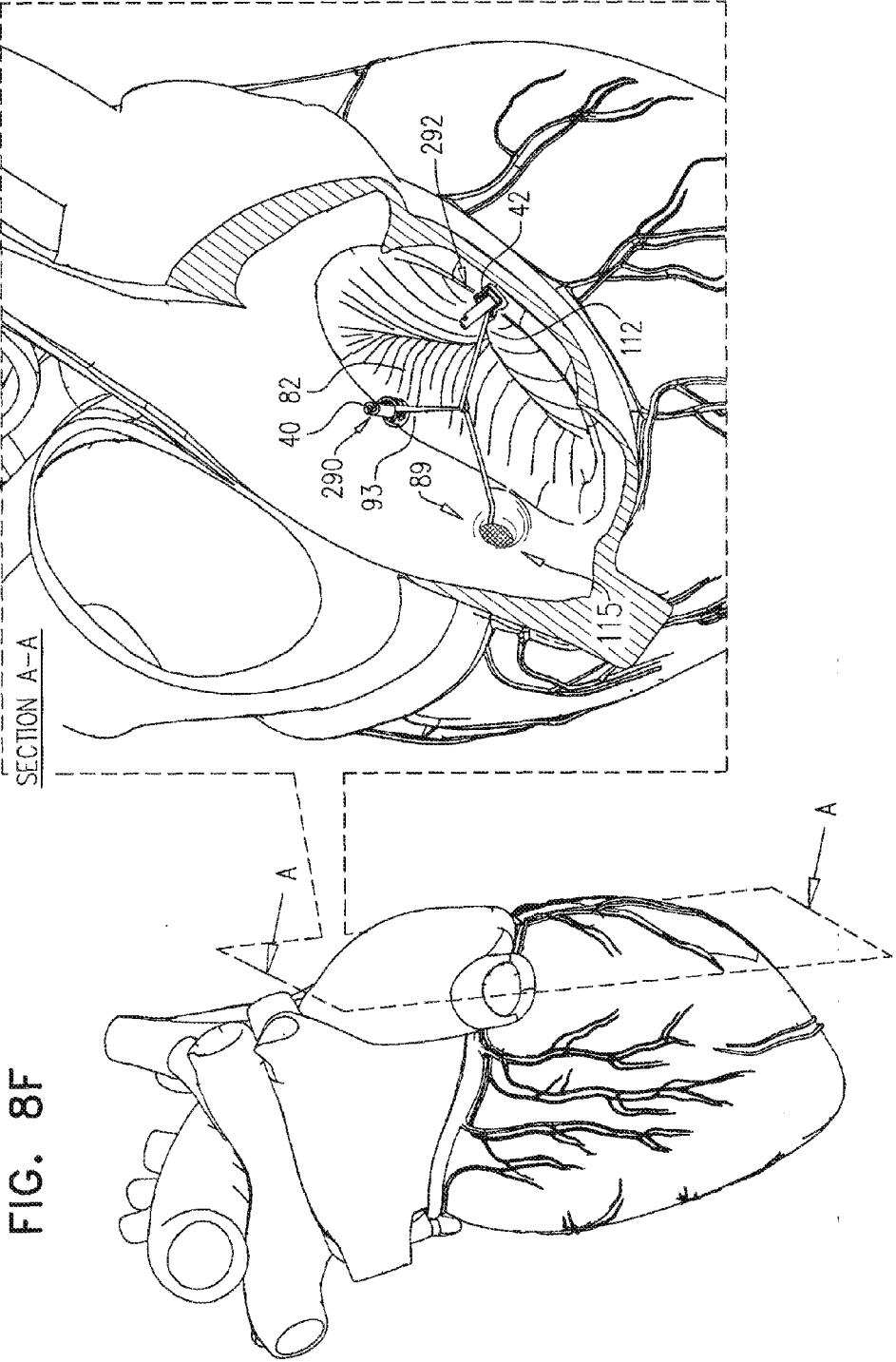
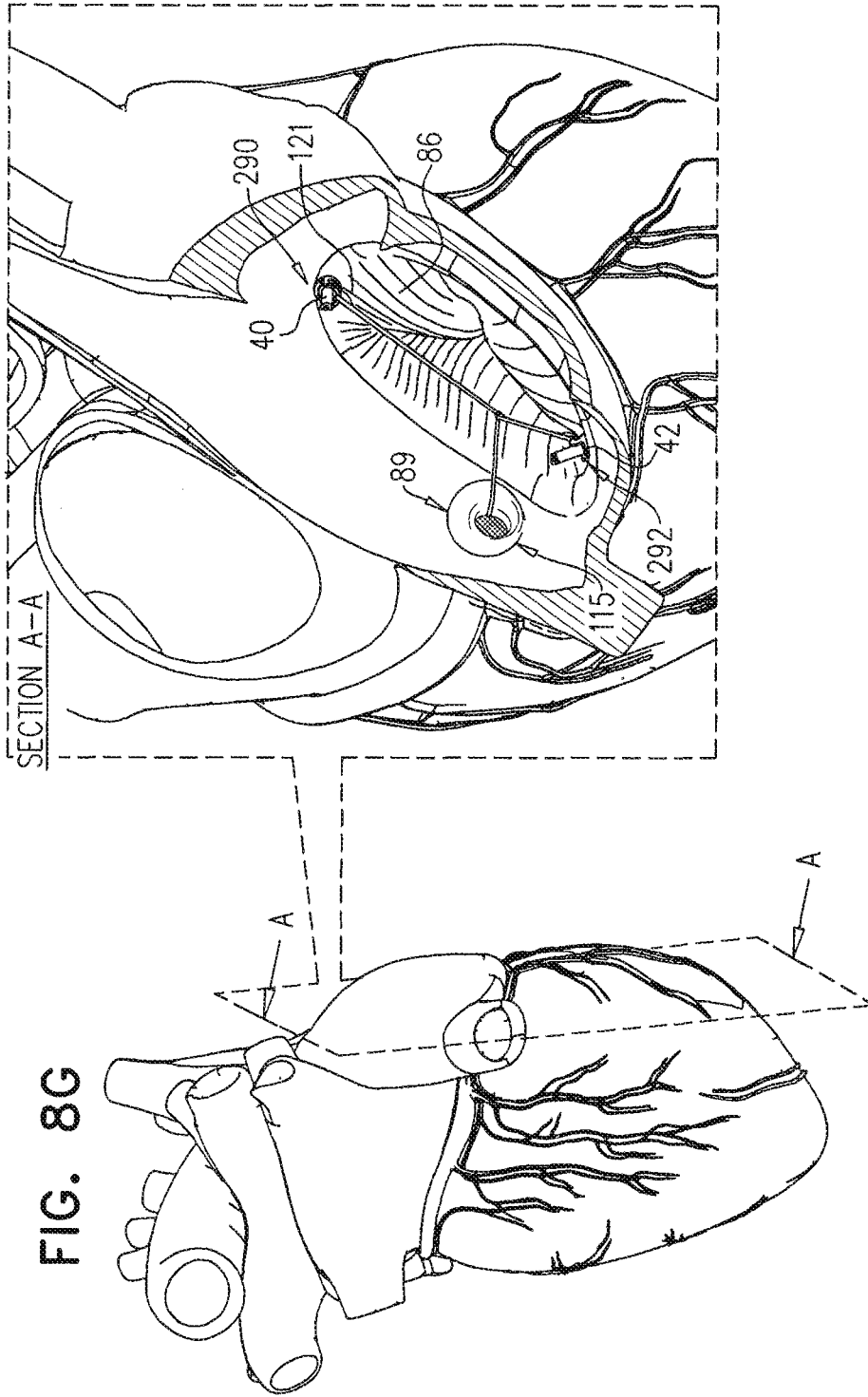


FIG. 8D









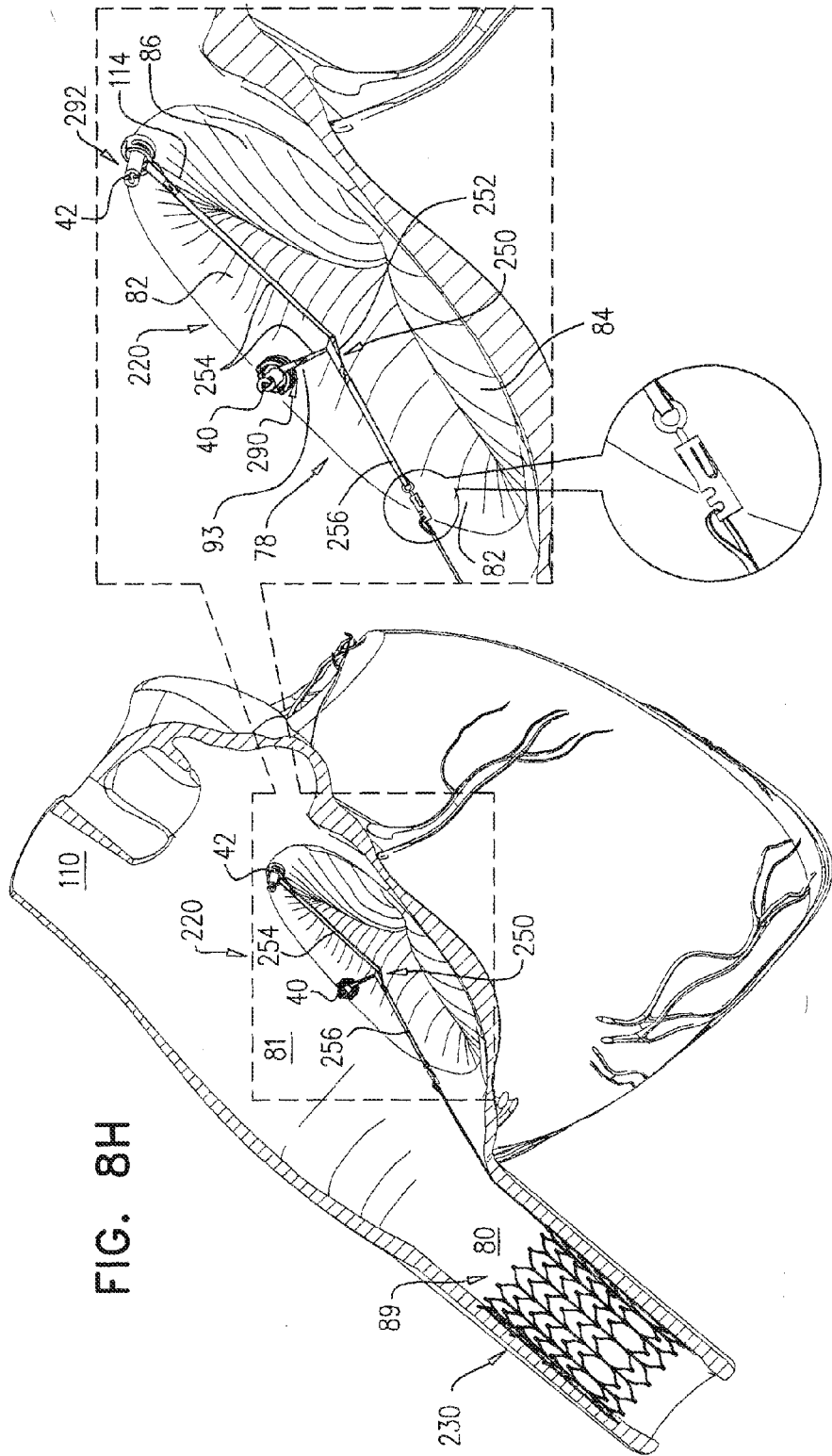
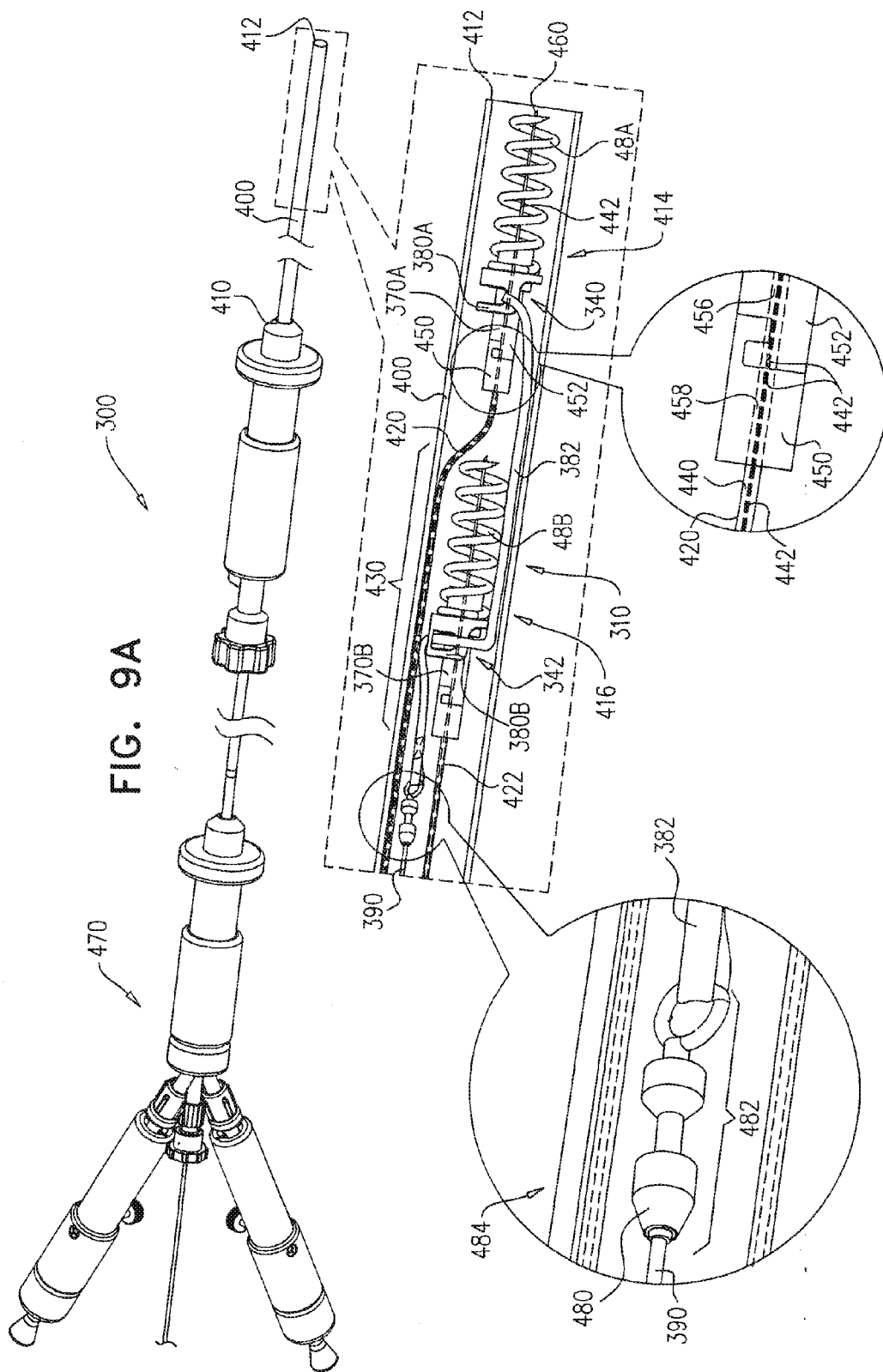
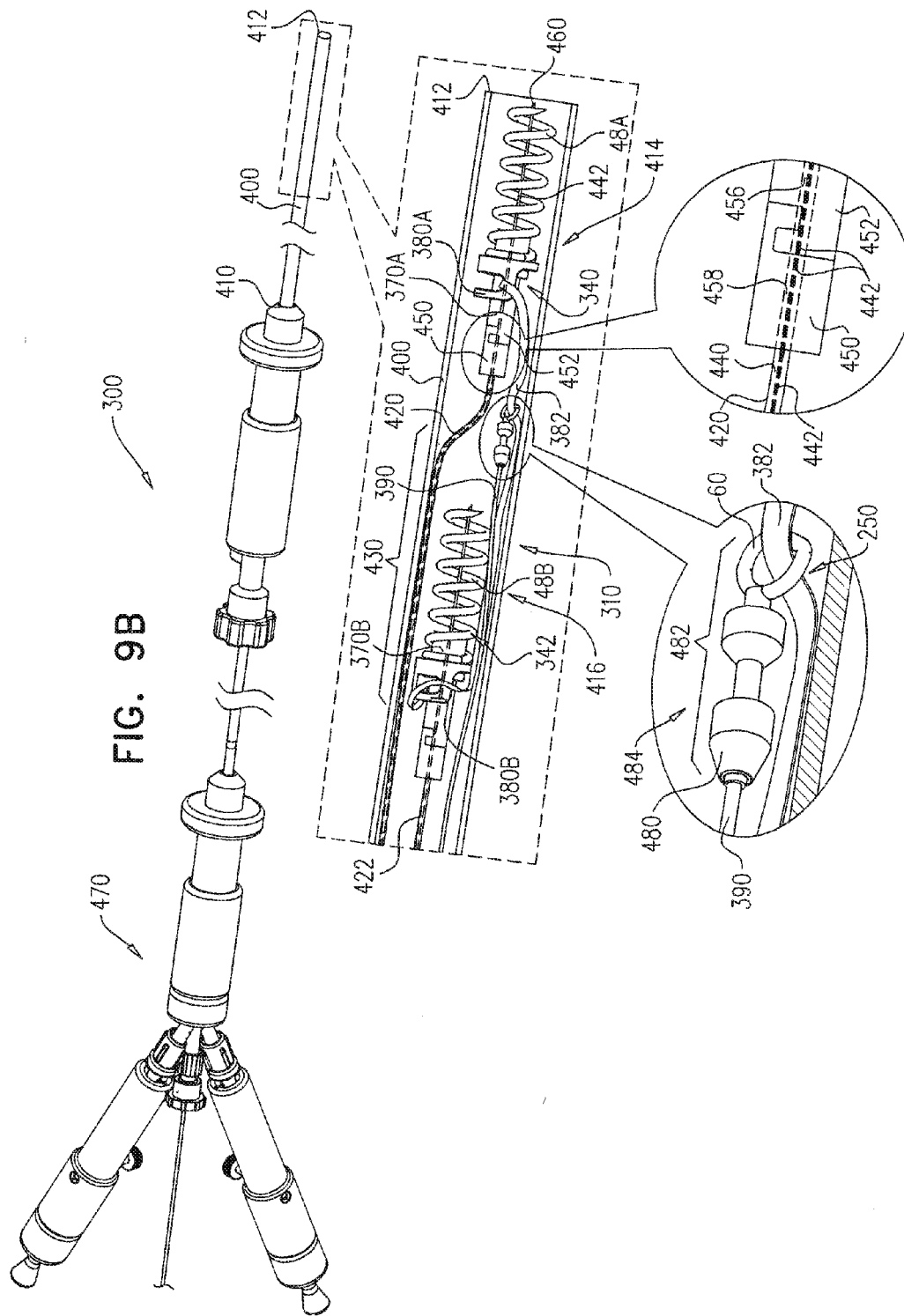
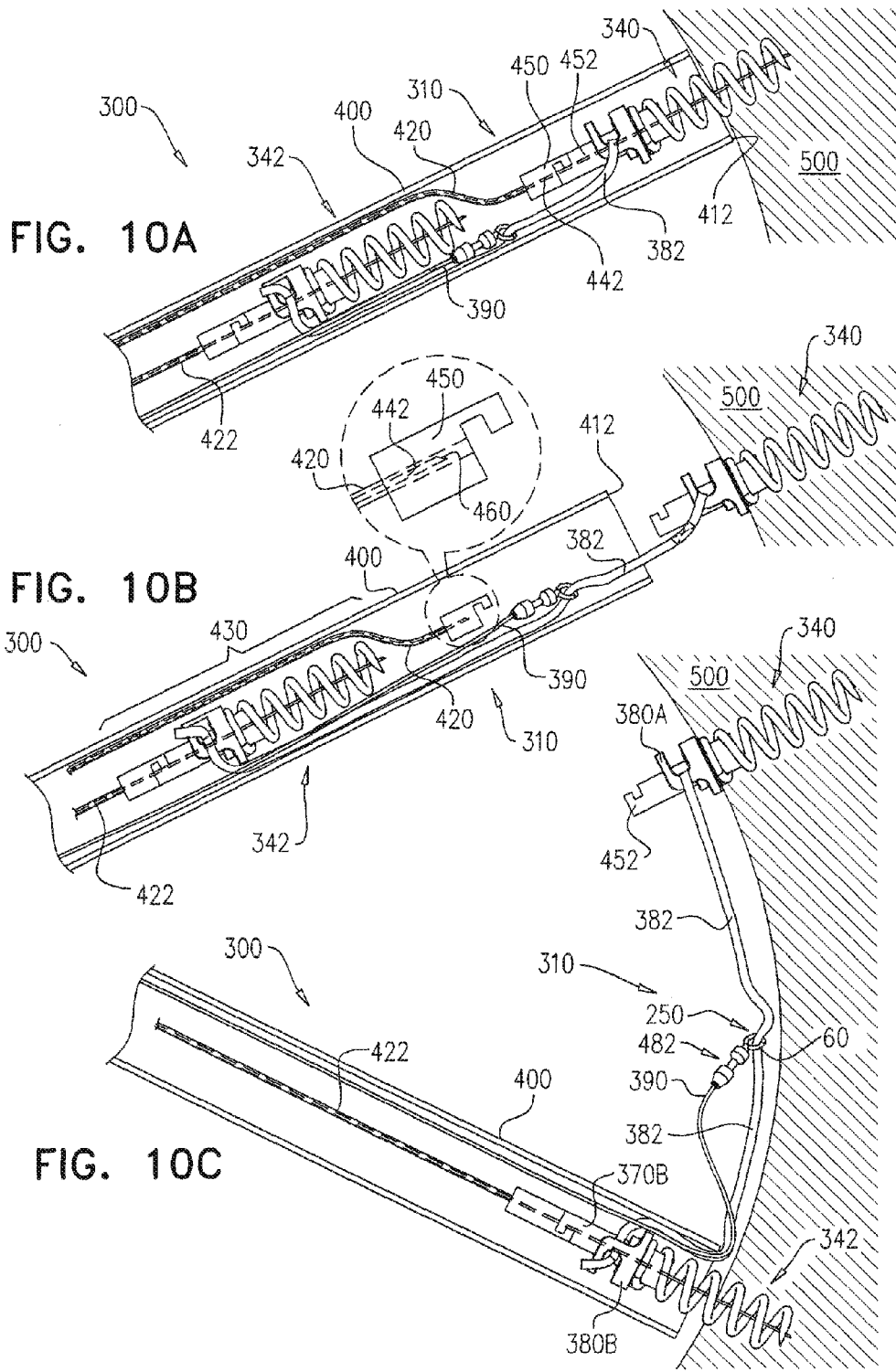
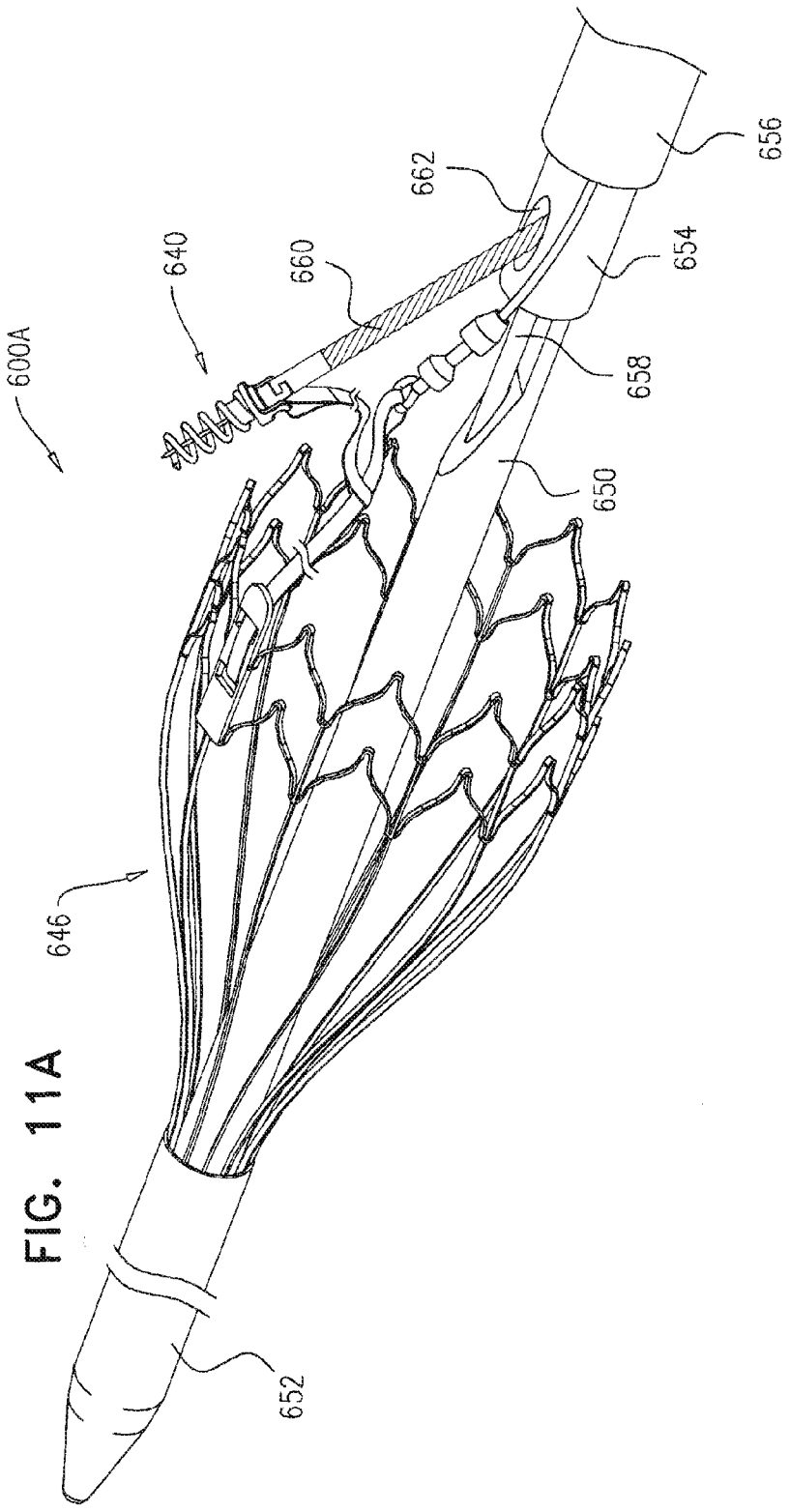


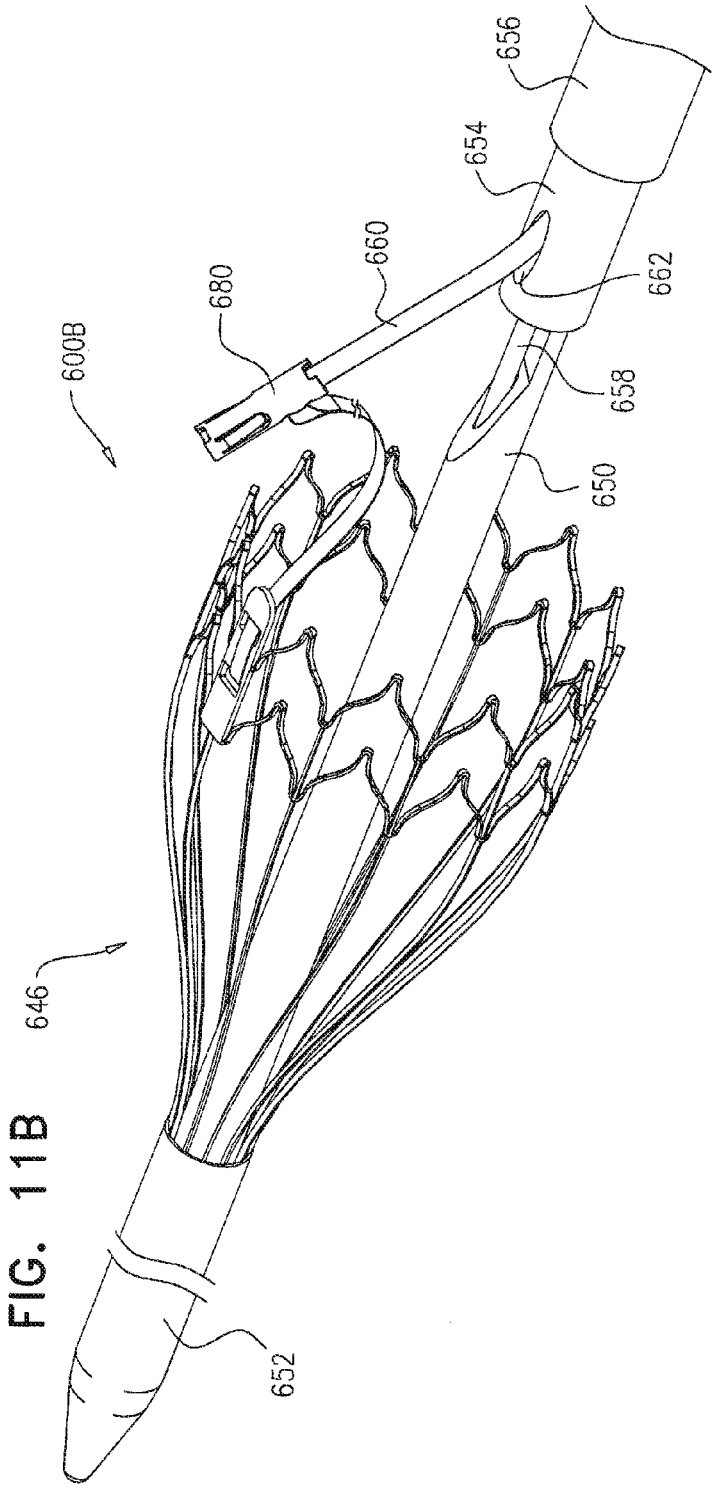
FIG. 8H











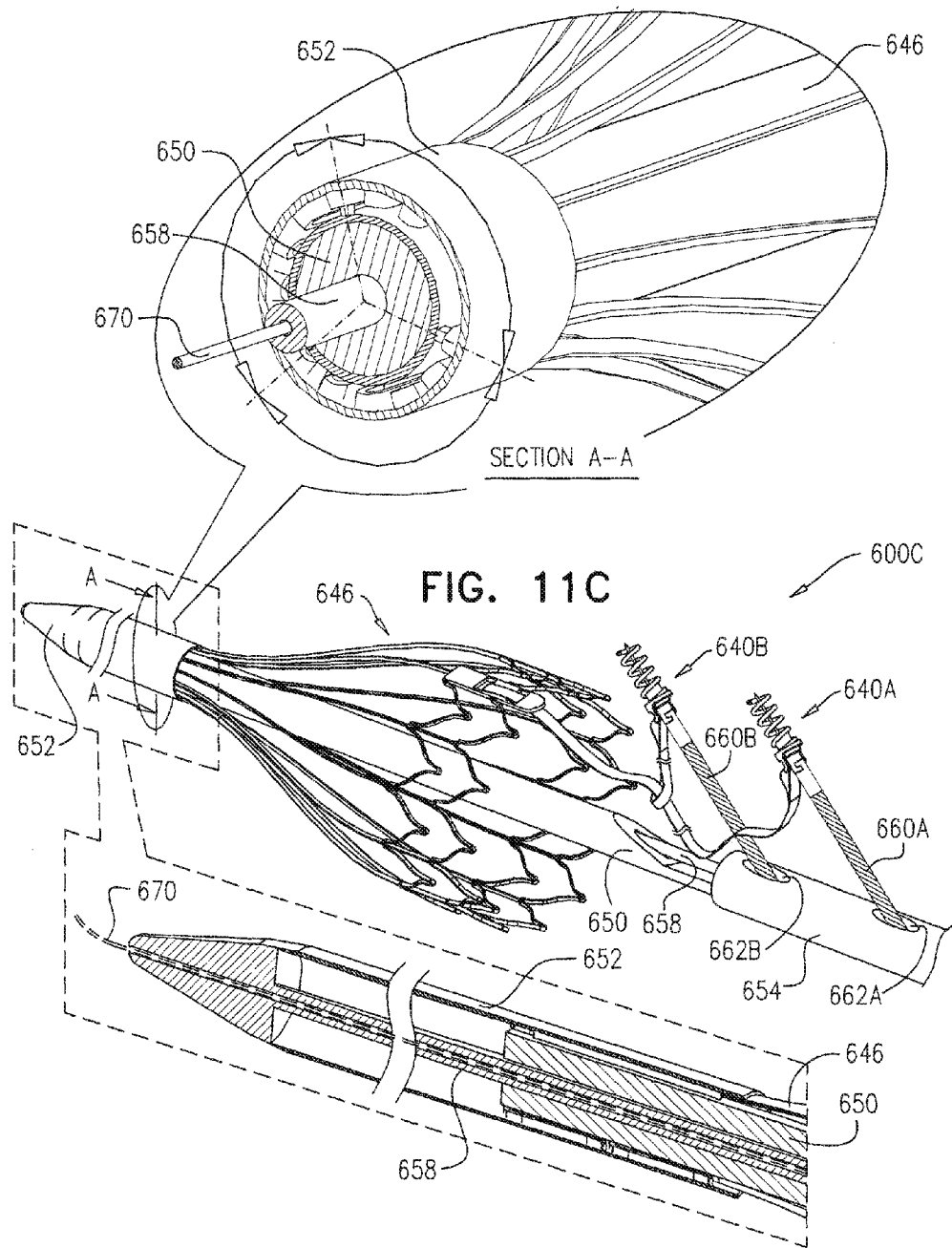
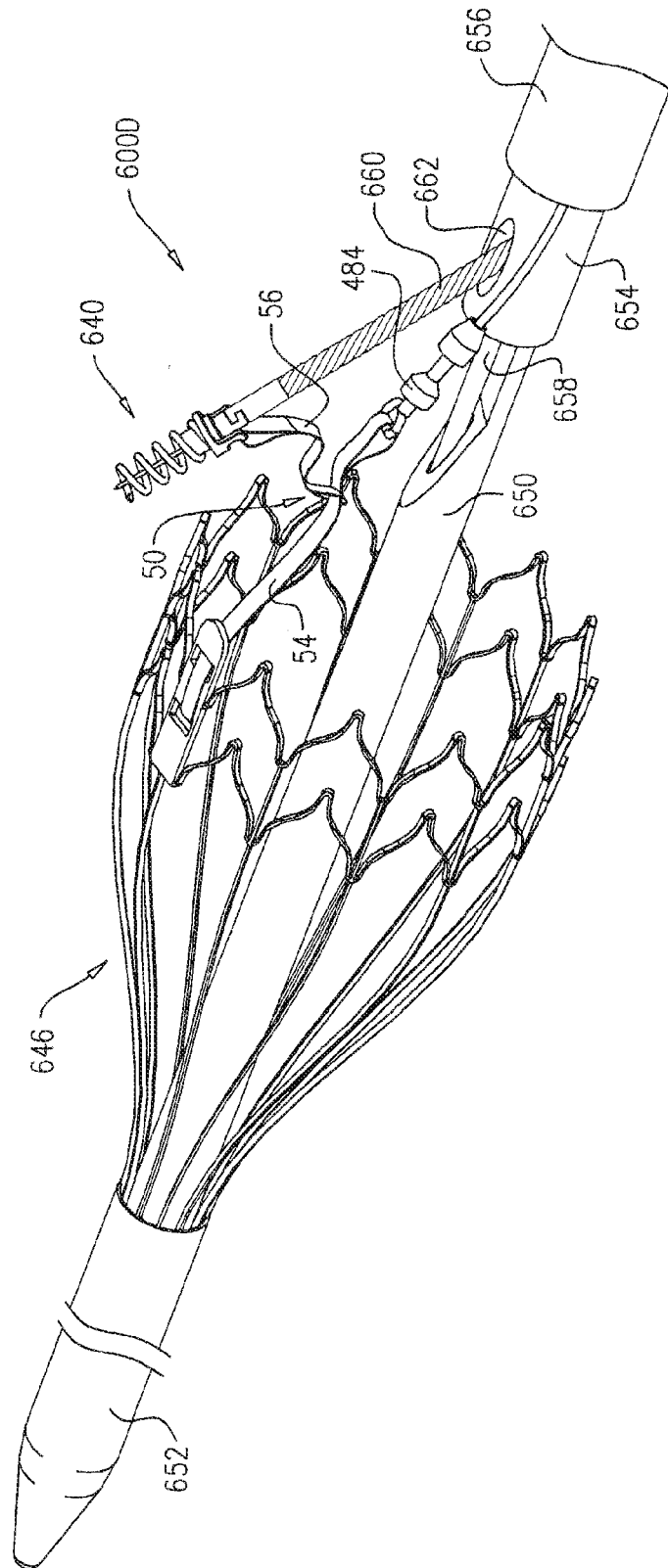
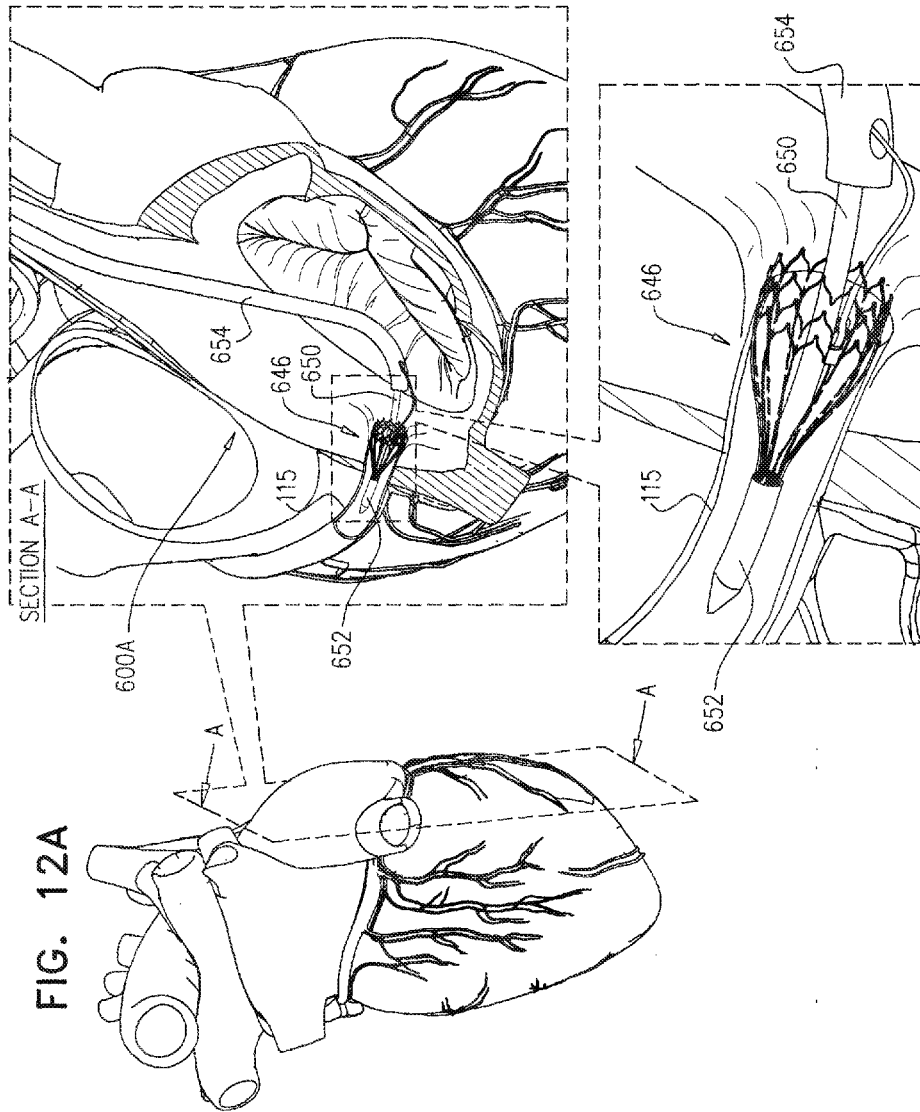
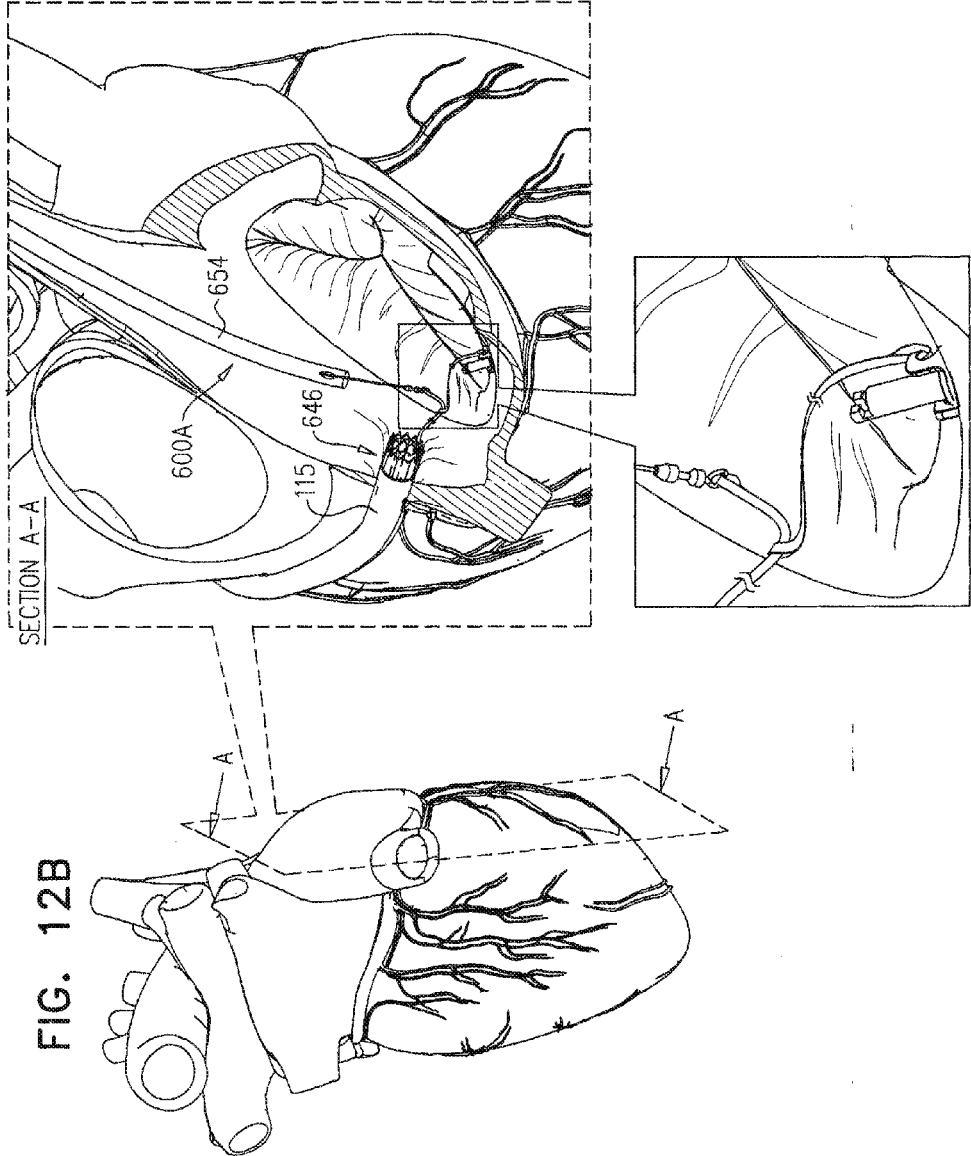


FIG. 11D







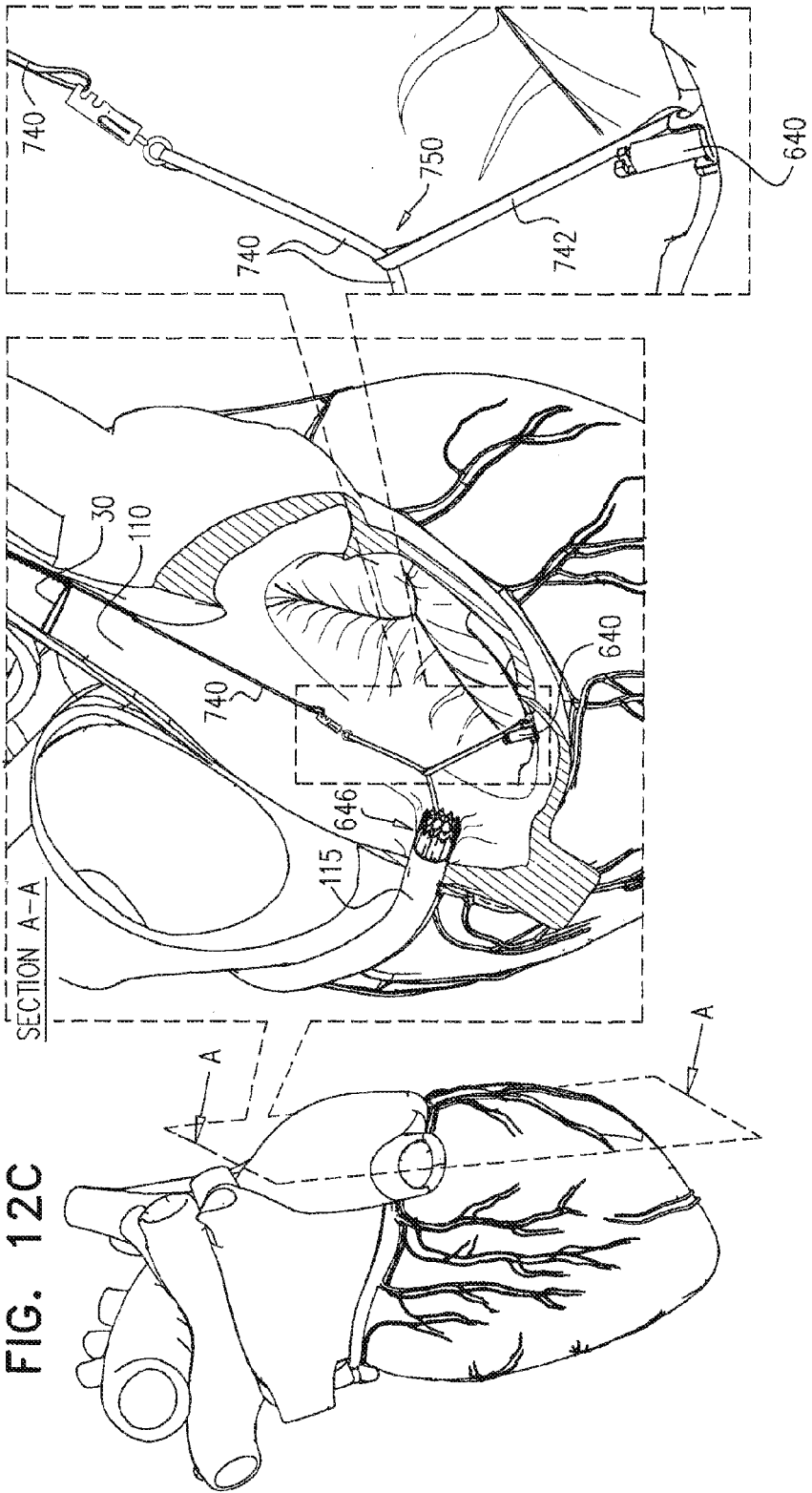


FIG. 12C

MULTIPLE ANCHORING-POINT TENSION SYSTEM

CROSS-REFERENCE TO RELATED APPLICATIONS

[0001] The present application is the US National Stage of International Application PCT/IB2014/002351, filed Oct. 28, 2014, which claims priority from U.S. Provisional Application 61/897,509, filed Oct. 30, 2013, which is assigned to the assignee of the present application and is incorporated herein by reference.

FIELD OF THE APPLICATION

[0002] Some applications of the present invention relate in general to valve repair. More specifically, some applications of the present invention relate to repair of an atrioventricular valve of a patient.

BACKGROUND OF THE APPLICATION

[0003] Functional tricuspid regurgitation (FTR) is governed by several pathophysiologic abnormalities such as tricuspid valve annular dilatation, annular shape abnormality, pulmonary hypertension, left or right ventricle dysfunction, right ventricle geometry, and leaflet tethering. Treatment options for FTR are primarily surgical. The current prevalence of moderate-to-severe tricuspid regurgitation is estimated to be 1.6 million in the United States. Of these, only 8,000 patients undergo tricuspid valve surgeries annually, most of them in conjunction with left heart valve surgeries.

SUMMARY OF THE INVENTION

[0004] In an application of the present invention, a valve-tensioning implant is provided for repairing an atrioventricular valve of a subject by applying tension using multiple anchor points. The valve-tensioning implant comprises at least first, second, and third tissue anchors, and a pulley system. The pulley system comprises a pulley and a first tether, which is connected to the second and the third tissue anchors, and is moveable through the pulley.

[0005] The pulley system is arranged so as to achieve a desired distribution and transfer of forces between the three or more tissue anchors. The pulley is arranged such that the maximum load applied when implanting the last of the tissue anchors (e.g., the third tissue anchor) is transferred between the other two tissue anchors that were earlier implanted (e.g., the first and the second tissue anchors). The load transferred to the first and the second tissue anchors approximates the first and the second tissue anchors. For some applications, two of the tissue anchors may be helical tissue anchors that are implanted around the annulus of the right atrium using mechanical purchase, and the other tissue anchor may comprise an intraluminal stent that is configured to be implanted in the superior vena cava, the inferior vena cava, or the coronary sinus and provide anchorage using friction only. The anchors and pulley system are arranged to apply relatively less force on the stent anchor than on one or both of the other helical tissue anchors. Alternatively or additionally, one of the tissue anchors may be located in a region of tissue which is thicker or stronger than the implantation sites at which the other tissue anchors are implanted. In addition, the pulley system may be arranged to align force vectors along a preferable direction which causes constriction of the tricuspid valve in a desired manner.

[0006] Repairing the atrioventricular valve typically facilitates reduction of atrioventricular valve regurgitation by altering the geometry of the atrioventricular valve and/or by altering the geometry of the wall of the right or left atrium of the heart. In some applications of the present invention, implantation of the valve-tensioning implant achieves bicuspidization of the tricuspid valve. For such applications, the anterior leaflet and the septal leaflet are typically drawn together to enhance coaptation.

[0007] In an application of the present invention, a multiple-anchor delivery tool is provided for sequentially delivering and implanting two or more helical tissue anchors of an implant. The implant comprises at least first and second helical tissue anchors, which comprise first and second heads, respectively, which comprise first and second tether interfaces. The implant also comprises a tether, which is connected to first tether interface, and coupled to second tether interface (optionally slidably coupled to second tether interface, such that the tether is moveable through the second tether interface).

[0008] The multiple-anchor delivery tool comprises a catheter shaft having proximal and distal ends. The first and the second tissue anchors are initially removably positioned in the catheter shaft at first and second longitudinal locations, respectively. The first longitudinal location is more distal than the second longitudinal location. In other words, the tissue anchors are initially positioned in the desired sequence of deployment in the tube, with the first anchor to be deployed positioned more distally than the subsequent anchor(s) to be deployed. The tissue anchors are interconnected by the tether.

[0009] The multiple-anchor delivery tool further comprises first and second torque cables, which (a) are removably coupled to the first and second heads, respectively, (b) extend within the tube proximally from the first and second heads, respectively, and (c) transmit torque when rotated, for rotating tissue-coupling elements of the anchors, respectively, into tissue. Typically, the torque cables additionally transmit axial force, to enable pushing of the tissue-coupling elements into the tissue as they are rotated. A portion of the first torque cable is initially removably positioned alongside the second tissue anchor in the tube. Thus each anchor is separately connected to a control handle of the multiple-anchor delivery tool by its own torque cable, which allows full and separate control of deployment of each anchor by an operator of the multiple-anchor delivery tool.

[0010] During use of multiple-anchor delivery tool for performing an implantation procedure, the first tissue anchor is implanted into tissue of the subject by rotating the first torque cable. The first torque cable is then decoupled from the first tissue anchor. After the first tissue anchor is implanted, the second tissue anchor is distally advanced in the tube. The second tissue anchor is implanted into tissue of the subject by rotating the second torque cable. The second torque cable is then decoupled from the second tissue anchor.

[0011] There is therefore provided, in accordance with an application of the present invention, apparatus including a valve-tensioning implant, which includes:

[0012] a first venous tissue anchor, which is configured to be implanted in a vein selected from the group of veins consisting of: a superior vena cava, an inferior vena cava, and a coronary sinus;

[0013] exactly two atrial tissue anchors, which consist of second and third atrial tissue anchors; and

[0014] a pulley system, which includes:

[0015] a pulley, which is connected to the second atrial tissue anchor; and

[0016] a tether, which (a) is connected to the first venous tissue anchor and the third atrial tissue anchor, (b) is moveable through the pulley, and (c) has a length, measured between the first venous and the third atrial tissue anchors, of at least 30 mm.

[0017] For some applications, the pulley includes a loop, and the tether is slidably moveable through the loop. For some applications, a coefficient of kinetic friction between the tether and the loop is less than 0.5, such as less 0.2, e.g., less than 0.1. For some applications, the loop includes a closed loop. For some applications, the pulley includes a ring, and the tether is slidably moveable through the ring. For some applications, a coefficient of kinetic friction between the tether and the ring is less than 0.5, such as less 0.2, e.g., less than 0.1. For some applications, the pulley includes a wheel.

[0018] For some applications, the first venous tissue anchor includes an intraluminal stent. For some applications, the second and the third atrial tissue anchors include respective helical tissue-coupling elements.

[0019] For any of the applications described above, the tether may be a first tether, the length may be a first length, and the pulley system may further include a second tether which (a) is connected to the pulley and the second atrial tissue anchor, so as to connect the pulley to the second atrial tissue anchor, and (b) has a second length, measured between the second atrial tissue anchor and the pulley, of at least 3 mm. For some applications, the second length equals at least 10% of the first length. For some applications, the first length is between 30 and 120 mm, and/or the second length is between 5 and 8 mm.

[0020] For any of the applications described above, the second atrial tissue anchor may include (a) a tissue-coupling element, and (b) a head, and the pulley may be connected to the head such that, when the pulley is fully extended away from the head, a distance between (a) a site on the pulley farthest from the head and (b) a site on the head closest to the pulley, is at least 3 mm. For some applications, the head is rigid. For some applications, the head includes a tether interface that is rotatable with respect to the tissue-coupling element.

[0021] For any of the applications described above, the second atrial tissue anchor may include (a) a tissue-coupling element, and (b) a head, which includes the pulley. For some applications, the head includes an interface, which (a) includes the pulley and (b) is rotatable with respect to the tissue-coupling element. For some applications, the pulley includes an eyelet. For some applications, the pulley includes a roller. For some applications, the pulley includes a flexible longitudinal member that is connected to the head at two points along the flexible longitudinal member, so as to define a loop longitudinally between the two points. For some applications, the second tissue-coupling element is helical. For some applications, the third atrial tissue anchor includes a helical tissue-coupling element.

[0022] For any of the applications described above, the apparatus may further include a delivery system, configured to deliver and enable implantation of the valve-tensioning implant, and the delivery system may include at least one catheter shaft.

[0023] There is further provided, in accordance with an application of the present invention, apparatus including a valve-tensioning implant, which includes:

[0024] a first venous tissue anchor, which is configured to be implanted in a vein selected from the group of veins consisting of: a superior vena cava, an inferior vena cava, and a coronary sinus;

[0025] exactly two tissue anchors, which consist of second and third atrial tissue anchors; and

[0026] a pulley system, which includes:

[0027] a pulley, which is connected to the first venous tissue anchor;

[0028] a first tether, which (a) is connected to the second and the third atrial tissue anchors, (b) is moveable through the pulley, and (c) has a first length, measured between the second and the third atrial tissue anchors, of at least 10 mm; and

[0029] a second tether, which (a) is connected to the first venous tissue anchor and to the pulley, and (b) has a second length, measured between the first venous tissue anchor and the pulley, of at least 30 mm.

[0030] For some applications, the pulley includes a loop, and the second tether is slidably moveable through the loop. For some applications, a coefficient of kinetic friction between the second tether and the loop is less than 0.5, such as less 0.2, e.g., less than 0.1. For some applications, the loop includes a closed loop. For some applications, the pulley includes a ring, and the second tether is slidably moveable through the ring. For some applications, a coefficient of kinetic friction between the second tether and the ring is less than 0.5, such as less 0.2, e.g., less than 0.1. For some applications, the pulley includes a wheel.

[0031] For some applications, the first venous tissue anchor includes an intraluminal stent. For some applications, the second and the third atrial tissue anchors include respective helical tissue-coupling elements. For some applications, the second length equals at least the first length. For some applications, the first length is between 20 and 50 mm. For some applications, the second length is between 30 and 80 mm.

[0032] For any of the applications described above, the apparatus may further include a delivery system, configured to deliver and enable implantation of the valve-tensioning implant, and the delivery system may include at least one catheter shaft.

[0033] There is still further provided, in accordance with an application of the present invention, apparatus including a valve-tensioning implant, which includes:

[0034] first, second, and third tissue anchors; and

[0035] a pulley system, which includes:

[0036] a pulley;

[0037] a first tether, which (a) is connected to the second and the third tissue anchors, (b) is moveable through the pulley, and (c) has a first length, measured between the second and the third tissue anchors, of at least 15 mm; and

[0038] a second tether, which (a) is connected to the first tissue anchor and to the pulley, and (b) has a second length, measured between the first tissue anchor and the pulley, of at least 15 mm.

[0039] For some applications, the apparatus includes exactly three tissue anchors, which consist of the first, the second, and the third tissue anchors, and no other tissue anchors.

[0040] For some applications, the pulley includes a loop, and the first tether is slidably moveable through the loop. For some applications, a coefficient of kinetic friction between the first tether and the loop is less than 0.5, such as less 0.2, e.g., less than 0.1. For some applications, the loop includes a closed loop. For some applications, the pulley includes a ring, and the first tether is slidably moveable through the ring. For some applications, a coefficient of kinetic friction between the first tether and the ring is less than 0.5, such as less 0.2, e.g., less than 0.1. For some applications, the pulley includes a wheel.

[0041] For some applications, the second length equals at least 80% of the first length. For some applications, the first length is between 15 and 30 mm. For some applications, the second length is between 25 and 80 mm. For some applications, the second length equals at least 15% of the first length. For some applications, the first length is between 15 and 140 mm. For some applications, the first length is between 30 and 120 mm.

[0042] For some applications, the third tissue anchor is configured to be implanted in a vein selected from the group of veins consisting of: a superior vena cava, an inferior vena cava, and a coronary sinus.

[0043] For any of the applications described above, the first anchor may be configured to be implanted in a vein selected from the group of veins consisting of: a superior vena cava, an inferior vena cava, and a coronary sinus. For some applications, the first tissue anchor includes an intraluminal stent. For some applications, the second and third tissue anchors include respective helical tissue-coupling elements.

[0044] For any of the applications described above, the third tissue anchor may include an intraluminal stent. For some applications, the first and the second tissue anchors include respective helical tissue-coupling elements.

[0045] For any of the applications described above, the apparatus may further include a delivery system, configured to deliver and enable implantation of the valve-tensioning implant, and the delivery system may include at least one catheter shaft.

[0046] There is additionally provided, in accordance with an application of the present invention, apparatus including a valve-tensioning implant, which includes:

[0047] a first tissue anchor, which includes (a) a tissue-coupling element, and (b) a head;

[0048] second and third tissue anchors; and

[0049] a pulley system, which includes:

[0050] a pulley, which is connected to the head of the first tissue anchor, such that, when the pulley is fully extended away from the head, a distance between (a) a site on the pulley farthest from the head and (b) a site on the head closest to the pulley, is at least 5 mm; and

[0051] a tether, which (a) is connected to the second and the third tissue anchors, (b) is moveable through the pulley, and (c) has a length, measured between the second and the third tissue anchors, of at least 15 mm.

[0052] For some applications, the head is rigid.

[0053] For some applications, the interface between the head of the tissue anchor and tether is rotatable with respect to the tissue-coupling element.

[0054] For some applications, the pulley includes a loop, and the tether is slidably moveable through the loop. For some applications, a coefficient of kinetic friction between the tether and the loop is less than 0.5, such as less 0.2, e.g., less than 0.1. For some applications, the loop includes a closed

loop. For some applications, the pulley includes a ring, and the tether is slidably moveable through the ring. For some applications, a coefficient of kinetic friction between the tether and the ring is less than 0.5, such as less 0.2, e.g., less than 0.1. For some applications, the pulley includes a wheel.

[0055] For some applications, the third tissue anchor is configured to be implanted in a vein selected from the group of veins consisting of: a superior vena cava, an inferior vena cava, and a coronary sinus.

[0056] For some applications, the third tissue anchor includes an intraluminal stent. For some applications, the tissue-coupling element of the first tissue anchor includes a first helical tissue-coupling element, and the second tissue anchor includes a second helical tissue-coupling element.

[0057] For some applications, the distance equals at least 10% of the length. For some applications, the length is between 30 and 200 mm. For some applications, the distance is between 15 and 50 mm.

[0058] For any of the applications described above, the apparatus may further include a delivery system, configured to deliver and enable implantation of the valve-tensioning implant, and the delivery system may include at least one catheter shaft.

[0059] There is yet additionally provided, in accordance with an application of the present invention, apparatus including a valve-tensioning implant, which includes:

[0060] a first venous tissue anchor, which is configured to be implanted in a vein selected from the group of veins consisting of: a superior vena cava and an inferior vena cava;

[0061] a second atrial tissue anchor;

[0062] a third venous tissue anchor, which is configured to be implanted in a coronary sinus; and

[0063] a pulley system, which includes:

[0064] a pulley, which is connected to the second atrial tissue anchor; and

[0065] a tether, which (a) is connected to the first and the third venous tissue anchors, (b) is moveable through the pulley, and (c) has a length, measured between the first venous and the third atrial tissue anchors, of at least 30 mm.

[0066] For some applications, the pulley includes a loop, and the tether is slidably moveable through the loop. For some applications, a coefficient of kinetic friction between the tether and the loop is less than 0.5, such as less 0.2, e.g., less than 0.1. For some applications, the loop includes a closed loop. For some applications, the pulley includes a ring, and the tether is slidably moveable through the ring. For some applications, a coefficient of kinetic friction between the tether and the ring is less than 0.5, such as less 0.2, e.g., less than 0.1. For some applications, the pulley includes a wheel.

[0067] For some applications, the first and the second venous tissue anchor includes first and second intraluminal stents, respectively. For some applications, a greatest outer diameter of the second intraluminal stent is no more than 80% of a greatest outer diameter of the first intraluminal stent, when the first and the second stents are unconstrained and fully radially expanded. For some applications, the second atrial tissue anchor includes a helical tissue-coupling element.

[0068] For any of the applications described above, the tether may be a first tether, the length may be a first length, and the pulley system may further include a second tether, which (a) is connected to the pulley and the second atrial tissue anchor, so as to connect the pulley to the second atrial tissue

anchor, and (b) has a second length, measured between the second atrial tissue anchor and the pulley, of at least 3 mm. For some applications, the second length equals at least 10% of the first length. For some applications, the first length is between 30 and 80 mm. For some applications, the second length is between 5 and 8 mm.

[0069] For any of the applications described above, the second atrial tissue anchor may include (a) a tissue-coupling element, and (b) a head, and the pulley may be connected to the head such that, when the pulley is fully extended away from the head, a distance between (a) a site on the pulley farthest from the head and (b) a site on the head closest to the pulley, is at least 3 mm. For some applications, the head is rigid. For some applications, the head includes an interface that is rotatable with respect to the tissue-coupling element.

[0070] For any of the applications described above, the second atrial tissue anchor may include (a) a tissue-coupling element, and (b) a head, which includes the pulley. For some applications, the head includes an interface, which (a) includes the pulley and (b) is rotatable with respect to the tissue-coupling element. For some applications, the pulley includes an eyelet. For some applications, the pulley includes a roller. For some applications, the pulley includes a flexible longitudinal member that is connected to the head at two points along the flexible longitudinal member, so as to define a loop longitudinally between the two points. For some applications, the tissue-coupling element is helical.

[0071] For any of the applications described above, the apparatus may further include a delivery system, configured to deliver and enable implantation of the valve-tensioning implant, and the delivery system may include at least one catheter shaft.

[0072] There is also provided, in accordance with an application of the present invention, apparatus including:

[0073] an implant, which includes:

[0074] at least first and second tissue anchors, which include (a) first and second helical tissue-coupling elements, respectively, and (b) first and second heads, respectively, which include first and second tether interfaces; and

[0075] a tether, which is connected to the first tether interface, and coupled to the second tether interface; and

[0076] a multiple-anchor delivery tool, which includes:

[0077] a catheter shaft having proximal and distal ends, wherein the first and the second tissue anchors are removably positioned in the catheter shaft at first and second longitudinal locations, respectively, the first longitudinal location more distal than the second longitudinal location; and

[0078] first and second torque cables, which (a) are removably coupled to the first and the second heads, respectively, (b) extend within the catheter shaft proximally from the first and the second heads, respectively, and (c) transmit torque when rotated, wherein a portion of the first torque cable is removably positioned alongside the second tissue anchor in the catheter shaft.

[0079] For some applications:

[0080] the implant further includes a third tissue anchor, which includes (a) a third helical tissue-coupling element and (b) a third head, which includes a third tether interface,

[0081] the tether, which is coupled to the third tether interface,

[0082] the third tissue anchor is removably positioned in the catheter shaft at a third longitudinal location that is more proximal than the second longitudinal location, and

[0083] the multiple-anchor delivery tool further includes a third torque cable, which (a) is removably coupled to the third head, (b) extends within the catheter shaft proximally from the third head, and (c) transmits torque when rotated, wherein a portion of the second torque cable is removably positioned alongside the third tissue anchor in the catheter shaft.

[0084] For some applications, the first tether interface is rotatable with respect to the first tissue-coupling element.

[0085] For any of the applications described above, the first torque cable may be shaped so as to define a lumen therethrough, and the multiple-anchor delivery tool may further include a shaft, which removably passes through the lumen. For some applications:

[0086] the head is shaped so as to define a proximal coupling element,

[0087] the head, including the proximal coupling element, is shaped so as to define a first longitudinal channel at least partially therethrough, which channel is coaxial with the head,

[0088] a distal end of the first torque cable includes a distal coupling element, which is shaped so as to define a second longitudinal channel therethrough, which channel is coaxial with the lumen of the first torque cable,

[0089] the proximal and the distal coupling elements are shaped so as to define corresponding interlocking surfaces, and

[0090] the shaft, when disposed through the first and the second channels, prevents decoupling of the distal coupling element from the proximal coupling element.

[0091] For some applications, the shaft is shaped so as to define a sharp distal tip.

[0092] There is further provided, in accordance with an application of the present invention, a method including:

[0093] implanting:

[0094] a first venous tissue anchor in a vein selected from the group of veins consisting of: a superior vena cava, an inferior vena cava, and a coronary sinus,

[0095] exactly two atrial tissue anchors, which consist of second and third atrial tissue anchors, at respective different atrial sites, each of which sites is selected from the group of sites consisting of: an annulus of a tricuspid valve, and a wall of a right atrium of a heart above the annulus of the tricuspid valve, and

[0096] a pulley system, which includes (a) a pulley, which is connected to the second atrial tissue anchor, and (b) a tether, which (i) is connected to the first venous tissue anchor and the third atrial tissue anchor, (ii) is moveable through the pulley, and (iii) has a length, measured between the first venous and the third atrial tissue anchors, of at least 30 mm; and

[0097] reducing a size of a tricuspid orifice by tensioning the tether.

[0098] For some applications, the pulley includes a loop, and tensioning the tether includes sliding the tether through the loop. For some applications, a coefficient of kinetic friction between the tether and the loop is less than 0.5, such as less than 0.2, e.g., less than 0.1. For some applications, the loop is a closed loop.

[0099] For some applications, the pulley includes a ring, and tensioning the tether includes sliding the tether through

the ring. For some applications, a coefficient of kinetic friction between the tether and the ring is less than 0.5, such as less 0.2, e.g., less than 0.1.

[0100] For some applications, the pulley includes a wheel, and tensioning the tether includes rotating the wheel by moving the tether through the pulley.

[0101] For some applications, the first venous tissue anchor includes an intraluminal stent, and implanting the first venous tissue anchor includes expanding the stent in the selected vein. For some applications, the second and the third atrial tissue anchors include respective helical tissue-coupling elements, and implanting the second and the third atrial tissue anchors includes rotating the helical tissue-coupling elements into tissue at the sites, respectively.

[0102] For some applications, implanting the first venous tissue anchor, the second atrial tissue anchor, the third atrial tissue anchor, and the pulley system includes positioning the first venous tissue anchor, the second atrial tissue anchor, the third atrial tissue anchor, and the pulley system such that two longitudinal portions of the tether adjacent to and on opposite sides of the pulley define an angle therebetween of between 40 and 85 degrees.

[0103] For some applications, implanting the first venous tissue anchor includes implanting the first venous tissue anchor in the inferior vena cava. For some applications, implanting the second atrial tissue anchor includes implanting the second atrial tissue anchor within 1 cm of a site on the annulus that circumferentially corresponds to a circumferential middle of a septal leaflet of the tricuspid valve; and implanting the third atrial tissue anchor includes implanting the third atrial tissue anchor within 1 cm of a site on the annulus that circumferentially corresponds to an anteroposterior commissure of the tricuspid valve.

[0104] For some applications, implanting the second atrial tissue anchor includes implanting the second atrial tissue anchor within 1 cm of a site on the annulus that circumferentially corresponds to a septoanterior commissure of the tricuspid valve; and implanting the third atrial tissue anchor includes implanting the third atrial tissue anchor within 1 cm of a site on the annulus that circumferentially corresponds to an anteroposterior commissure of the tricuspid valve.

[0105] For some applications, implanting the second atrial tissue anchor includes implanting the second atrial tissue anchor within 1 cm of a site on the annulus that circumferentially corresponds to an anteroposterior commissure of the tricuspid valve. For some applications, implanting the third atrial tissue anchor includes implanting the third atrial tissue anchor within 1 cm of a site on the annulus that circumferentially corresponds to a septoanterior commissure of the tricuspid valve. For some applications, implanting the third atrial tissue anchor includes implanting the third atrial tissue anchor within 1 cm of a site on the annulus that circumferentially corresponds to a circumferential middle of a septal leaflet of the tricuspid valve. For some applications, implanting the third atrial tissue anchor includes implanting the third atrial tissue anchor in the coronary sinus. For some applications, implanting the second atrial tissue anchor includes implanting the second atrial tissue anchor within 1 cm of a site on the annulus that circumferentially corresponds to an anteroposterior commissure of the tricuspid valve; and implanting the third atrial tissue anchor includes implanting the third atrial tissue anchor within 1 cm of a site on the annulus that circumferentially corresponds to a septoanterior commissure of the tricuspid valve. For some applications,

implanting the second atrial tissue anchor includes implanting the second atrial tissue anchor within 1 cm of a site on the annulus that circumferentially corresponds to a septoanterior commissure of the tricuspid valve; and implanting the third atrial tissue anchor includes implanting the third atrial tissue anchor within 1 cm of a site on the annulus that circumferentially corresponds to a septoposterior commissure of the tricuspid valve.

[0106] For some applications, implanting the first venous tissue anchor includes implanting the first venous tissue anchor in the superior vena cava. For some applications, implanting the second atrial tissue anchor includes implanting the second atrial tissue anchor within 1 cm of a site on the annulus that circumferentially corresponds to an anteroposterior commissure of the tricuspid valve. For some applications, implanting the third atrial tissue anchor includes implanting the third atrial tissue anchor within 1 cm of a site on the annulus that circumferentially corresponds to a septoanterior commissure of the tricuspid valve. For some applications, implanting the third atrial tissue anchor includes implanting the third atrial tissue anchor within 1 cm of a site on the annulus that circumferentially corresponds to a circumferential middle of a septal leaflet of the tricuspid valve. For some applications, implanting the third atrial tissue anchor includes implanting the third atrial tissue anchor in the coronary sinus. For some applications, implanting the second atrial tissue anchor includes implanting the second atrial tissue anchor within 1 cm of a site on the annulus that circumferentially corresponds to a septoanterior commissure of the tricuspid valve; and implanting the third atrial tissue anchor includes implanting the third atrial tissue anchor within 1 cm of a site on the annulus that circumferentially corresponds to an anteroposterior commissure of the tricuspid valve. For some applications, implanting the second atrial tissue anchor includes implanting the second atrial tissue anchor within 1 cm of a site on the annulus that circumferentially corresponds to a circumferential middle of a septal leaflet of the tricuspid valve; and implanting the third atrial tissue anchor includes implanting the third atrial tissue anchor within 1 cm of a site on the annulus that circumferentially corresponds to an anteroposterior commissure of the tricuspid valve.

[0107] For some applications, implanting the first venous tissue anchor includes implanting the first venous tissue anchor in the coronary sinus. For some applications, implanting the second atrial tissue anchor includes implanting the second atrial tissue anchor within 1 cm of a site on the annulus that circumferentially corresponds to an anteroposterior commissure of the tricuspid valve; and implanting the third atrial tissue anchor includes implanting the third atrial tissue anchor within 1 cm of a site on the annulus that circumferentially corresponds to a septoanterior commissure of the tricuspid valve.

[0108] For some applications, the tether is a first tether; the length is a first length; the pulley system further includes a second tether, which (a) is connected to the pulley and the second atrial tissue anchor, so as to connect the pulley to the second atrial tissue anchor, and (b) has a second length, measured between the second atrial tissue anchor and the pulley, of at least 3 mm; and implanting the pulley system further includes implanting the second tether.

[0109] For some applications, the second atrial tissue anchor includes (a) a tissue-coupling element, and (b) a head; the pulley is connected to the head; and tensioning the tether includes fully extending the pulley away from the head, such

that a distance between (a) a site on the pulley farthest from the head and (b) a site on the head closest to the pulley, is at least 3 mm.

[0110] For some applications, the head is rigid. For some applications, the head includes a tether interface that is rotatable with respect to the tissue-coupling element.

[0111] For some applications, implanting the first venous tissue anchor, the second atrial tissue anchor, the third atrial tissue anchor, and the pulley system includes positioning the first venous tissue anchor, the second atrial tissue anchor, the third atrial tissue anchor, and the pulley system such that two longitudinal portions of the tether adjacent to and on opposite sides of the pulley define an angle therebetween of at least 120 degrees. For some applications, the angle is at least 135 degrees.

[0112] For some applications, implanting the first venous tissue anchor, the second atrial tissue anchor, the third atrial tissue anchor, and the pulley system includes positioning the first venous tissue anchor, the second atrial tissue anchor, the third atrial tissue anchor, and the pulley system such that two longitudinal portions of the tether adjacent to and on opposite sides of the pulley define an angle there between of less than 90 degrees. For some applications, the angle is less than 60 degrees.

[0113] For some applications, the second atrial tissue anchor includes (a) a tissue-coupling element, and (b) a head, which includes the pulley, and implanting the second atrial tissue anchor includes implanting the head. For some applications, the head includes an interface, which (a) includes the pulley, and (b) is rotatable with respect to the tissue-coupling element. For some applications, the pulley includes an eyelet. For some applications, the pulley includes a roller. For some applications, the pulley includes a flexible longitudinal member that is connected to the head at two points along the flexible longitudinal member, so as to define a loop longitudinally between the two points. For some applications, the tissue-coupling element is helical. For some applications, the third atrial tissue anchor includes a helical tissue-coupling element.

[0114] There is still further provided, in accordance with an application of the present invention, a method including:

[0115] implanting:

[0116] a first venous tissue anchor in a vein selected from the group of veins consisting of: a superior vena cava, an inferior vena cava, and a coronary sinus,

[0117] exactly two atrial tissue anchors, which consist of second and third atrial tissue anchors, at respective different atrial sites, each of which sites is selected from the group of sites consisting of: an annulus of a tricuspid valve, and a wall of a right atrium of a heart above the annulus of the tricuspid valve, and

[0118] a pulley system, which includes (a) a pulley, which is connected to the first venous tissue anchor, (b) a first tether, which (i) is connected to the second and the third atrial tissue anchors, (ii) is moveable through the pulley, and (iii) has a first length, measured between the second and the third atrial tissue anchors, of at least 10 mm, and (c) a second tether, which (i) is connected to the first venous tissue anchor and to the pulley, and (ii) has a second length, measured between the first venous tissue anchor and the pulley, of at least 30 mm; and

[0119] reducing a size of a tricuspid orifice by tensioning the second tether.

[0120] For some applications, the pulley includes a loop, and tensioning the first tether includes sliding the first tether through the loop. For some applications, a coefficient of kinetic friction between the first tether and the loop is less than 0.5, such as less 0.2, e.g., less than 0.1. For some applications, the loop is a closed loop. For some applications, the pulley includes a ring, and tensioning the first tether includes sliding the first tether through the ring. For some applications, a coefficient of kinetic friction between the first tether and the ring is less than 0.5, such as less 0.2, e.g., less than 0.1. For some applications, the pulley includes a wheel.

[0121] For some applications, the first venous tissue anchor includes an intraluminal stent, and implanting the first venous tissue anchor includes expanding the stent in the selected vein. For some applications, the second and the third atrial tissue anchors include respective helical tissue-coupling elements, and implanting the second and the third atrial tissue anchors includes rotating the helical tissue-coupling elements into tissue at the sites, respectively.

[0122] For some applications, implanting the first venous tissue anchor, the second atrial tissue anchor, the third atrial tissue anchor, and the pulley system includes positioning the first venous tissue anchor, the second atrial tissue anchor, the third atrial tissue anchor, and the pulley system such that two longitudinal portions of the first tether adjacent to and on opposite sides of the pulley define an angle therebetween of at least 120 degrees. For some applications, positioning the first venous tissue anchor, the second atrial tissue anchor, the third atrial tissue anchor, and the pulley system such that the two longitudinal portions of the first tether adjacent to and on the opposite sides of the pulley define an angle therebetween of at least 135 degrees.

[0123] For some applications, implanting the first venous tissue anchor includes implanting the first venous tissue anchor in the inferior vena cava. For some applications, implanting the second atrial tissue anchor includes implanting the second atrial tissue anchor within 1 cm of a site on the annulus that circumferentially corresponds to an anteroposterior commissure of the tricuspid valve. For some applications, implanting the third atrial tissue anchor includes implanting the third atrial tissue anchor within 1 cm of a site on the annulus that circumferentially corresponds to a septoanterior commissure of the tricuspid valve. For some applications, implanting the third atrial tissue anchor includes implanting the third atrial tissue anchor within 1 cm of a site on the annulus that circumferentially corresponds to a circumferential middle of a septal leaflet of the tricuspid valve.

[0124] For some applications, implanting the first venous tissue anchor includes implanting the first venous tissue anchor in the superior vena cava. For some applications, implanting the third atrial tissue anchor includes implanting the third atrial tissue anchor within 1 cm of a site on the annulus that circumferentially corresponds to an anteroposterior commissure of the tricuspid valve. For some applications, implanting the second atrial tissue anchor includes implanting the second atrial tissue anchor within 1 cm of a site on the annulus that circumferentially corresponds to a septoanterior commissure of the tricuspid valve. For some applications, implanting the second atrial tissue anchor includes implanting the second atrial tissue anchor within 1 cm of a site on the annulus that circumferentially corresponds to a circumferential middle of a septal leaflet of the tricuspid valve.

[0125] For some applications, implanting the first venous tissue anchor includes implanting the first venous tissue

anchor in the coronary sinus. For some applications, implanting the third atrial tissue anchor includes implanting the third atrial tissue anchor within 1 cm of a site on the annulus that circumferentially corresponds to an anteroposterior commissure of the tricuspid valve. For some applications, implanting the second atrial tissue anchor includes implanting the second atrial tissue anchor within 1 cm of a site on the annulus that circumferentially corresponds to a septoanterior commissure of the tricuspid valve. For some applications, implanting the second atrial tissue anchor includes implanting the second atrial tissue anchor within 1 cm of a site on the annulus that circumferentially corresponds to a circumferential middle of a septal leaflet of the tricuspid valve.

[0126] There is additionally provided, in accordance with an application of the present invention, a method including:

[0127] implanting:

[0128] first, second, and third tissue anchors at respective different sites, and

[0129] a pulley system, which includes (a) a pulley, (b) a first tether, which (i) is connected to the second and the third tissue anchors, (ii) is moveable through the pulley, and (iii) has a first length, measured between the second and the third tissue anchors, of at least 15 mm, and (c) a second tether, which (i) is connected to the first tissue anchor and to the pulley, and (ii) has a second length, measured between the first tissue anchor and the pulley, of at least 15 mm; and

[0130] reducing a size of a tricuspid orifice by tensioning the second tether.

[0131] For some applications, implanting the first, the second, and the third tissue anchors includes implanting exactly three tissue anchors, which consist of the first, the second, and the third tissue anchors, and no other tissue anchors.

[0132] For some applications, the pulley includes a loop, and tensioning the second tether includes sliding the first tether through the loop. For some applications, a coefficient of kinetic friction between the first tether and the loop is less than 0.5, such as less 0.2, e.g., less than 0.1. For some applications, the loop is a closed loop. For some applications, the pulley includes a ring, and tensioning the second tether includes sliding the first tether through the ring. For some applications, a coefficient of kinetic friction between the first tether and the ring is less than 0.5, such as less 0.2, e.g., less than 0.1. For some applications, the pulley includes a wheel.

[0133] For some applications, implanting the first anchor includes implanting the first anchor in a vein selected from the group of veins consisting of: a superior vena cava, an inferior vena cava, and a coronary sinus. For some applications, the first tissue anchor includes an intraluminal stent, and implanting the first tissue anchor includes implanting the stent in the selected vein. For some applications, the second and third tissue anchors include respective helical tissue-coupling elements, and implanting the second and the third tissue anchors includes rotating the helical tissue-coupling elements into tissue at the sites, respectively.

[0134] For some applications, implanting the third tissue anchor includes implanting the third tissue anchor in a vein selected from the group of veins consisting of: a superior vena cava, an inferior vena cava, and a coronary sinus. For some applications, the third tissue anchor includes an intraluminal stent, and implanting the third tissue anchor includes implanting the stent in the selected vein. For some applications, the first and the second tissue anchors include respective helical tissue-coupling elements, and implanting the first and the

second tissue anchors includes rotating the helical tissue-coupling elements into tissue at the sites, respectively.

[0135] There is yet additionally provided, in accordance with an application of the present invention, a method including:

[0136] implanting:

[0137] a first tissue anchor, which includes (a) a tissue-coupling element and (b) a head,

[0138] second and third tissue anchors, and

[0139] a pulley system, which includes (a) a pulley, which is connected to the head of the first tissue anchor, and (b) a tether, which (i) is connected to the second and the third tissue anchors, (ii) is moveable through the pulley, and (iii) has a length, measured between the second and the third tissue anchors, of at least 15 mm; and

[0140] reducing a size of a tricuspid orifice by tensioning the tether, so as to fully extend the pulley away from the head, such that a distance between (a) a site on the pulley farthest from the head and (b) a site on the head closest to the pulley, is at least 5 mm.

[0141] For some applications, the head is rigid.

[0142] For some applications, the head includes an interface that is rotatable with respect to the tissue-coupling element.

[0143] For some applications, the pulley includes a loop, and tensioning the tether includes sliding the tether through the loop. For some applications, a coefficient of kinetic friction between the tether and the loop is less than 0.5, such as less 0.2, e.g., less than 0.1. For some applications, the loop is a closed loop. For some applications, the pulley includes a ring, and tensioning the tether includes sliding the tether through the ring. For some applications, a coefficient of kinetic friction between the tether and the ring is less than 0.5, such as less 0.2, e.g., less than 0.1. For some applications, the pulley includes a wheel.

[0144] For some applications, implanting the third tissue anchor includes implanting the third tissue anchor in a vein selected from the group of veins consisting of: a superior vena cava, an inferior vena cava, and a coronary sinus.

[0145] For some applications, the third tissue anchor includes an intraluminal stent, and implanting the third tissue anchor includes implanting the stent in the selected vein. For some applications, the tissue-coupling element of the first tissue anchor includes a first helical tissue-coupling element, the second tissue anchor includes a second helical tissue-coupling element, and implanting the first and the second tissue anchors includes rotating the first and the second helical tissue-coupling elements into tissue, respectively.

[0146] There is also provided, in accordance with an application of the present invention, a method including:

[0147] implanting:

[0148] a first venous tissue anchor in a vein selected from the group of veins consisting of: a superior vena cava and an inferior vena cava,

[0149] a second atrial tissue anchor at an atrial site selected from the group of sites consisting of: an annulus of a tricuspid valve, and a wall of a right atrium of a heart above the annulus of the tricuspid valve,

[0150] a third venous tissue anchor in a coronary sinus, and

[0151] a pulley system, which includes (a) a pulley, which is connected to the second atrial tissue anchor, and (b) a tether, which (i) is connected to the first and the

third venous tissue anchors, (ii) is moveable through the pulley, and (iii) has a length, measured between the first venous and the third atrial tissue anchors, of at least 15 mm; and

[0152] reducing a size of a tricuspid orifice by tensioning the tether.

[0153] For some applications, the pulley includes a loop, and tensioning the tether includes sliding the tether through the loop. For some applications, a coefficient of kinetic friction between the tether and the loop is less than 0.5, such as less than 0.2, e.g., less than 0.1. For some applications, the loop is a closed loop. For some applications, the pulley includes a ring, and tensioning the tether includes sliding the tether through the ring. For some applications, a coefficient of kinetic friction between the tether and the ring is less than 0.5, such as less than 0.2, e.g., less than 0.1. For some applications, the pulley includes a wheel, and tensioning the tether includes rotating the wheel by moving the tether through the pulley.

[0154] For some applications:

[0155] the first and the third venous tissue anchor include first and second intraluminal stents, respectively,

[0156] implanting the first venous tissue anchor includes expanding the first stent in the selected vein, and

[0157] implanting the third venous tissue anchor includes expanding the second stent in the coronary sinus.

[0158] For some applications, a greatest outer diameter of the second intraluminal stent is no more than 80% of a greatest outer diameter of the first intraluminal stent, when the first and the second stents are unconstrained and fully radially expanded. For some applications, the second atrial tissue anchor includes a helical tissue-coupling element, and implanting the second atrial tissue anchor includes rotating the helical tissue-coupling element into tissue at the site.

[0159] For some applications, implanting the first venous tissue anchor, the second atrial tissue anchor, the third venous tissue anchor, and the pulley system includes positioning the first venous tissue anchor, the second atrial tissue anchor, the third venous tissue anchor, and the pulley system such that two longitudinal portions of the tether adjacent to and on opposite sides of the pulley define an angle therebetween of between 120 and 180 degrees. For some applications, implanting the first venous tissue anchor includes implanting the first venous tissue anchor in the inferior vena cava. For some applications, implanting the second atrial tissue anchor includes implanting the second atrial tissue anchor within 1 cm of a site on the annulus that circumferentially corresponds to an anteroposterior commissure of the tricuspid valve. For some applications, implanting the first venous tissue anchor includes implanting the first venous tissue anchor in the superior vena cava. For some applications, implanting the second atrial tissue anchor includes implanting the second atrial tissue anchor within 1 cm of a site on the annulus that circumferentially corresponds to an anteroposterior commissure of the tricuspid valve.

[0160] For some applications, the tether is a first tether; the length is a first length; the pulley system further includes a second tether, which (a) is connected to the pulley and the second atrial tissue anchor, so as to connect the pulley to the second atrial tissue anchor, and (b) has a second length, measured between the second atrial tissue anchor and the pulley, of at least 3 mm; and implanting the pulley system further includes implanting the second tether.

[0161] For some applications, the second atrial tissue anchor includes (a) a tissue-coupling element, and (b) a head;

the pulley is connected to the head; and tensioning the tether includes fully extending the pulley away from the head, such that a distance between (a) a site on the pulley farthest from the head and (b) a site on the head closest to the pulley, is at least 3 mm. For some applications, the head is rigid. For some applications, the head includes an interface that is rotatable with respect to the tissue-coupling element.

[0162] For some applications, the second atrial tissue anchor includes (a) a tissue-coupling element, and (b) a head, which includes the pulley, and implanting the second atrial tissue anchor includes implanting the head. For some applications, the head includes an interface, which (a) includes the pulley, and (b) is rotatable with respect to the tissue-coupling element. For some applications, the pulley includes an eyelet. For some applications, the pulley includes a roller. For some applications, the pulley includes a flexible longitudinal member that is connected to the head at two points along the flexible longitudinal member, so as to define a loop longitudinally between the two points. For some applications, the tissue-coupling element is helical.

[0163] There is further provided, in accordance with an application of the present invention, a method including:

[0164] advancing a distal end of a catheter shaft of a multiple-anchor delivery tool into a body of a subject, while (a) first and second tissue anchors are removably positioned in the catheter shaft at first and second longitudinal locations, respectively, the first longitudinal location more distal than the second longitudinal location, wherein the first and the second tissue anchors include (i) first and second helical tissue-coupling elements, respectively, and (ii) first and second heads, respectively, which include first and second tether interfaces, and (b) a tether, which is connected to the first tether interface, and is coupled to the second tether interface, is removably positioned in the catheter shaft, wherein the multiple-anchor delivery tool includes first and second torque cables, which (a) are removably coupled to the first and the second heads, respectively, (b) extend within the catheter shaft proximally from the first and the second heads, respectively, and (c) transmit torque when rotated, wherein a portion of the first torque cable is removably positioned alongside the second tissue anchor in the catheter shaft;

[0165] implanting the first tissue anchor into tissue of the subject by rotating the first torque cable;

[0166] decoupling the first torque cable from the first tissue anchor;

[0167] after implanting the first tissue anchor, distally advancing the second tissue anchor in the catheter shaft;

[0168] implanting the second tissue anchor into tissue of the subject by rotating the second torque cable; and

[0169] decoupling the second torque cable from the second tissue anchor.

[0170] For some applications, the first torque cable is shaped so as to define a lumen therethrough; the multiple-anchor delivery tool further includes a sharpened wire, which removably passes through the lumen, and which is initially positioned such that a distal end of the sharpened wire extends distally out of a distal end of the lumen; and the method further includes withdrawing the sharpened wire proximally.

[0171] For some applications:

[0172] the head is shaped so as to define a proximal coupling element,

[0173] the head, including the proximal coupling element, is shaped so as to define a first longitudinal channel at least partially therethrough, which channel is coaxial with the head.

[0174] a distal end of the first torque cable includes a distal coupling element, which is shaped so as to define a second longitudinal channel therethrough, which channel is coaxial with the lumen of the first torque cable,

[0175] the proximal and the distal coupling elements are shaped so as to define corresponding interlocking surfaces,

[0176] the sharpened wire, when disposed through the first and the second channels, prevents decoupling of the distal coupling element from the proximal coupling element, and

[0177] withdrawing the sharpened wire proximally includes decoupling the distal coupling element from the proximal coupling element by withdrawing the sharpened wire proximally.

[0178] For some applications, the sharpened wire is shaped so as to define a sharp distal tip. For some applications, implanting the first tissue anchor includes inserting the sharp distal tip of the sharpened wire into the tissue.

[0179] For some applications:

[0180] advancing includes advancing the distal end of the catheter shaft into the body while (a) a third tissue anchor is removably positioned in the catheter shaft at a third longitudinal location that is more proximal than the second longitudinal location, the third tissue anchor includes (i) a third helical tissue-coupling elements and (ii) a third head, which includes a third tether interface, (b) the tether is coupled to the third tether interface,

[0181] the multiple-anchor delivery tool further includes a third torque cable, which (a) is removably coupled to the third head, (b) extends within the catheter shaft proximally from the third head, and (c) transmits torque when rotated, a portion of the second torque cable is removably positioned alongside the third tissue anchor in the catheter shaft, and

[0182] the method further includes:

[0183] after implanting the second tissue anchor, distally advancing the third tissue anchor in the catheter shaft;

[0184] implanting the third tissue anchor into tissue of the subject by rotating the third torque cable; and

[0185] decoupling the third torque cable from the third tissue anchor.

[0186] For some applications, the first tether interface is rotatable with respect to the first tissue-coupling element.

[0187] The present invention will be more fully understood from the following detailed description of applications thereof, taken together with the drawings, in which:

BRIEF DESCRIPTION OF THE DRAWINGS

[0188] FIG. 1 is a schematic illustration of a valve-tensioning implant, in accordance with an application of the present invention;

[0189] FIGS. 2A-D are schematic illustrations of several configurations of a pulley of the valve-tensioning implant of FIG. 1, in accordance with respective applications of the present invention;

[0190] FIGS. 3A-O are schematic illustrations of implantations of the valve-tensioning implant of FIG. 1, in accordance with respective applications of the present invention;

[0191] FIG. 4 is a schematic illustration of another valve-tensioning implant, in accordance with an application of the present invention;

[0192] FIGS. 5A-B are schematic illustrations of two configurations of a pulley of the valve-tensioning implant of FIG. 4, in accordance with respective applications of the present invention;

[0193] FIGS. 6A-I are schematic illustrations of implantations of the valve-tensioning implant of FIG. 4, in accordance with respective applications of the present invention;

[0194] FIG. 7 is a schematic illustration of yet another valve-tensioning implant, in accordance with an application of the present invention;

[0195] FIGS. 8A-H are schematic illustrations of implantations of the valve-tensioning implant of FIG. 7, in accordance with respective applications of the present invention;

[0196] FIGS. 9A and 9B are schematic illustrations of a delivery system comprising a multiple-anchor delivery tool, in accordance with respective applications of the present invention; and

[0197] FIGS. 10A-C are schematic illustrations of a deployment method using the multiple-anchor delivery tool and implant shown in FIG. 9B, in accordance with an application of the present invention;

[0198] FIGS. 11A-D are schematic illustrations of a delivery system comprising respective multiple-anchor delivery tools, in accordance with respective applications of the present invention; and

[0199] FIGS. 12A-C are schematic illustrations of the deployment of a valve-tensioning implant system using the multiple-anchor delivery tool of FIG. 11A, in accordance with an application of the present invention.

DETAILED DESCRIPTION OF APPLICATIONS

[0200] FIG. 1 is a schematic illustration of a valve-tensioning implant system 20, in accordance with an application of the present invention. Valve-tensioning implant system 20 is configured to repair an atrioventricular valve of a subject (e.g., a tricuspid valve), using tension applied between multiple anchors of the implant. Typically, repair of the atrioventricular valve facilitates a reduction in atrioventricular valve regurgitation by altering the geometry of the atrioventricular valve and/or by altering the geometry of the wall of the right or left atrium of a heart of the subject.

[0201] For some applications, valve-tensioning implant system 20 comprises a first venous tissue anchor 30, such as exactly one first venous tissue anchor 30. First venous tissue anchor 30 is configured to be implanted at an implantation site upstream of the atrioventricular valve. For example, for applications in which the atrioventricular valve is the tricuspid valve, first venous tissue anchor 30 is typically configured to be implanted in a vein selected from the group of veins consisting of: a superior vena cava (SVC) 110 (such as described hereinbelow with reference to FIGS. 3E-H, 3M, and 3O), an inferior vena cava (IVC) 80 (such as described hereinbelow with reference to FIGS. 3A-D, 3I, and 3L), and a coronary sinus 115 (such as described hereinbelow with reference to FIGS. 3J-M). Valve-tensioning implant system 20 further comprises second and third atrial tissue anchors 40 and 42. For some applications, valve-tensioning implant system 20 comprises exactly two atrial tissue anchors, which consist of second and third atrial tissue anchors 40 and 42.

[0202] Valve-tensioning implant system 20 further comprises a pulley system 44, which comprises:

[0203] a pulley 50, which is connected (e.g., permanently fixed) to second atrial tissue anchor 40; and

[0204] a tether **54**, which is connected (e.g., permanently fixed) to first venous tissue anchor **30** and third atrial tissue anchor **42**, and is moveable through pulley **50**.

[0205] Tether **54** comprises an elongate flexible element, such as a cord, suture, or band. Typically, tether **54** has a high tensile strength and low friction, in order to enable the tether to apply tension, as described hereinbelow. Typically, tether **54** has a length, measured between first venous tissue anchor **30** and third atrial tissue anchor **42**, of at least 15 mm, no more than 200 mm, and/or between 15 and 200 mm, such as at least 30 mm, no more than 120 mm, and/or between 30 and 120 mm. The length equals the sum of (a) a first sub-length **L1** of a first portion of the tether between first venous tissue anchor **30** and pulley **50** and (b) a second sub-length **L2** of a second portion of the tether between pulley **50** and third atrial tissue anchor **42**. (First and second sub-lengths **L1** and **L2** are not fixed, because tether **54** is both moveable through pulley **50** as well as rotatable around the pivot point; however, the sum of the two sub-lengths is fixed.) Because tether **54** typically has a high tensile strength, the length thereof does not vary based on the particular disposition of the tether at any given point in time. In other words, the length of the tether does not depend on the amount of force applied to it. For some applications, tether **54** is configured so as to define an anchor-fixing loop **66**, which passes through a corresponding interface (e.g., defined by struts of the stent) on first venous tissue anchor **30**, so as to connect (e.g., permanently fix) the tether to the first venous tissue anchor.

[0206] For some applications, tether **54** comprises two separate sections **54A** and **54B**, which may be connected by an intraluminal locking mechanism **55** that comprises coupling elements (e.g., male and female coupling elements), which are connected during the implantation procedure, such as in order to allow implantation of first venous tissue anchor **30** with a separate catheter delivery system, such as described in US Patent Application Publication 2013/0018459, which is assigned to the assignee of the present application, and is incorporated herein by reference, such as with reference to FIGS. 20-32 thereof.

[0207] Reference is made to FIGS. 2A-D, which are schematic illustrations of several configurations of pulley **50**, in accordance with respective applications of the present invention. As used in the present application, including in the claims, a “pulley” is an element that transfers force along a tether, changing a direction of the force without substantially changing a magnitude of the force, while the tether moves through the pulley. As used herein, a pulley need not comprise a wheel, as is common in conventional pulleys. For some applications, a wheel is not necessary because the movement required during the cardiac cycle is reciprocal (back-and-forth) in nature, and limited in magnitude, about a few millimeters in each direction. It is noted that at some time after implantation, tissue growth may inhibit or entirely obstruct the tether’s movement through the pulley, thereby disabling the pulley’s “pulley” functionality. As used in the present application, including the claims, the feature that the tether is moveable through the pulley characterizes the pulley system at least at the time of implantation, but not necessarily after implantation.

[0208] For some applications, as shown in FIGS. 2A and 2B (and in FIG. 1), pulley **50** comprises a loop **52**, through which tether **54** is slidably moveable. Typically, a coefficient of kinetic friction between the tether and the loop is less than 0.5, such as less than 0.2, e.g., less than 0.1. For some appli-

cations, as shown in FIGS. 1 and 2A, loop **52** comprises a closed loop; in other words, the ends of the loop are joined together. For other applications, as shown in FIG. 2B, loop **52** comprises an open loop; both ends of the cord that defines the loop are connected (e.g., permanently fixed) to second atrial tissue anchor **40**, but not to one another. In other words, pulley **50** comprises a flexible longitudinal member that is connected (e.g., permanently fixed) to the head of anchor **40** at two points along the flexible longitudinal member, so as to define loop **52** longitudinally between the two points.

[0209] For some applications, such as shown in FIG. 2C, pulley **50** comprises a ring **60**, through which tether **54** is slidably moveable. Typically, a coefficient of kinetic friction between tether **54** and ring **60** is less than 0.5, such as less than 0.2, e.g., less than 0.1. For some applications, such as shown in FIG. 2D, pulley **50** comprises a wheel **62** on an axle that supports movement of tether **54** along the wheel’s circumference. Wheel **62** typically is shaped so as to define a groove between two flanges around its circumference, as is well-known in the pulley art. Pulley **50** may alternatively comprise an eyelet or a roller, such as described hereinbelow with reference to FIGS. 4 and 5A-B.

[0210] Reference is again made to FIG. 1. For some applications, first venous tissue anchor **30** comprises an intraluminal stent **46**. The stent is configured to be implanted in the vein by applying an outward radial force to the wall of the vein. Typically, the stent is configured to self-expand. For example, the stent may comprise a shape-memory alloy, such as Nitinol. Alternatively, the stent comprises a deformable metal, and is expanded by a tool, such as a balloon. For some applications, stent **46** comprises a plurality of interconnected superelastic metallic struts, arranged so as to allow crimping the stent into a relatively small diameter (typically less than 8 mm) catheter, while allowing deployment to a much larger diameter (typically more than 20 mm) in the vein, while still maintaining radial force against the tissue of the wall of the vein, in order to anchor stent **46** to the wall of the vein by friction. Typically, the stent is configured to not penetrate tissue of the wall of the vein. For some applications, stent **46** implements techniques described in U.S. Provisional Application 61/783,224, filed Mar. 14, 2013, which is assigned to the assignee of the present application and is incorporated herein by reference.

[0211] For some applications, second and third atrial tissue anchors **40** and **42** comprise respective helical tissue-coupling elements **48A** and **48B**, which puncture and screw into the cardiac muscle tissue. For some applications, second and third atrial tissue anchors **40** and **42** implement techniques described in U.S. Provisional Application 61/750,427, filed Jan. 9, 2013. Alternatively, each of second and third atrial tissue anchors **40** and **42** comprises a clip, jaws, or a clamp which grips and squeezes a portion of cardiac muscle tissue and does not puncture the cardiac muscle tissue.

[0212] For some applications, as shown in FIG. 1, tether **54** is a first tether **54**, and the length of first tether **54** is a first length. Pulley system **44** further comprises a second tether **56**, which is connected (e.g., permanently fixed) to pulley **50** and second atrial tissue anchor **40**, so as to fix pulley **50** to second atrial tissue anchor **40**. Second tether **56** comprises an elongate flexible element, such as a cord, a suture, or a band (e.g., a textile band). Typically, second tether **56** has a high tensile strength. Typically, second tether **56** has a second length **L3**, measured between second atrial tissue anchor **40** and pulley **50**, of at least 3 mm, no more than 20 mm, and/or between 3

and 20 mm, such as at least 5 mm, no more than 8 mm, and/or between 5 and 8 mm. Because second tether **56** typically has a high tensile strength, the length thereof does not vary based on the particular disposition of the second tether at any given point in time. In other words, the length of the second tether does not depend on the tensile forces applied to it. For some applications, the second length equals at least 10% of the first length, no more than 50% of the first length, and/or between 10% and 50% of the second length, such as at least 20% of the first length, no more than 40% of the second length, and/or between 20% and 40% of the second length. For some applications, second tether **56** is configured so as to define an anchor-fixing loop **68**, which passes through a corresponding interface on second atrial tissue anchor **40**, so as to connect (e.g., permanently fix) the second tether to the second atrial tissue anchor.

[0213] For some applications, second atrial tissue anchor **40** comprises (a) tissue-coupling element **48A** (which is optionally helical) and (b) a head **70**. Pulley **50** is connected (e.g., permanently fixed) to head **70** such that, when pulley **50** is fully extended away from the head, a distance **D1** between (a) a site **72** on pulley **50** farthest from head **70** and (b) a site **74** on head **70** closest to pulley **50**, is at least 3 mm (e.g., at least 5 mm), no more than 40 mm, and/or between 3 and 40 mm or between 5 and 40 mm. For some applications, distance **D1** equals at least 10% of the length of tether **54**, no more than 50% of the length of tether **54**, and/or between 10% and 50% of the length of tether **54**. Typically, head **70** comprises a tether interface **71**, to which second tether **56** is connected (such as by anchor-fixing loop **68**). Typically, tether interface **71** is rotatable with respect to tissue-coupling element **48A**. For some applications, head **70** is rotatable with respect to tissue-coupling element **48A**, so that tether interface **71** is rotatable with respect to tissue-coupling element **48A**. Alternatively, tether interface **71** is rotatable with respect to head **70** (which may be rotationally fixed with respect to tissue-coupling element **48A**), such that tether interface **71** is rotatable with respect to tissue-coupling element **48A**.

[0214] Reference is now made to FIGS. 3A-O, which are schematic illustrations of implantations of valve-tensioning implant system **20**, in accordance with respective applications of the present invention. The implantations are typically performed transvascularily, using a delivery system comprising one or more catheters introduced with the aid of a guidewire, through vasculature of the subject, such as (a) via the femoral vein, through inferior vena cava **80**, and into a right atrium **81**, (b) via the basilic vein, through the subclavian vein through superior vena cava **110**, and into right atrium **81**, or (c) via the external jugular vein, through the subclavian vein through superior vena cava **110**, and into right atrium **81**. (Right atrium **81** includes a septal leaflet **82**, a posterior leaflet **84**, and an anterior leaflet **86**.) The procedure is typically performed with the aid of imaging, such as fluoroscopy, transesophageal echo, and/or echocardiography. The procedure may be performed using techniques described in US Patent Application Publication 2012/0035712, which is assigned to the assignee of the present application and is incorporated herein by reference, with reference to FIGS. 1A-D thereof, mutatis mutandis, and/or using techniques described hereinbelow with reference to FIGS. 9A-B, 10A-C, 11A-D, and/or 12A-C, mutatis mutandis.

[0215] Second and third atrial tissue anchors **40** and **42**, e.g., exactly second and third atrial tissue anchors **40** and **42**, are implanted at respective different second and third atrial

sites **90** and **92**, each of which sites is selected from the group of sites consisting of: an annulus **83** of a tricuspid valve **78**, and a wall of right atrium **81** of the heart above annulus **83**. For applications in which second and third atrial tissue anchors **40** and **42** comprise respective helical tissue-coupling elements **48A** and **48B**, the helical tissue-coupling elements are rotated into tissue at the sites, respectively.

[0216] First venous tissue anchor **30** is implanted at a first site **89** in a vein selected from the group of veins consisting of: superior vena cava **110** (as shown, for example, in FIGS. 3E-H, 3M, and 3O), inferior vena cava **80** (as shown, for example, in FIGS. 3A-D, 3I, and 3L), and coronary sinus **115** (as shown, for example, in FIGS. 3J-K). For applications in which first venous tissue anchor **30** comprises intraluminal stent **46**, the stent is expanded in the selected vein in order to anchor the stent to the wall of the vein by the outward radial force applied by the stent. (As used herein, including in the claims, the labels “first,” “second,” and “third” of first, second, and third sites **89**, **90**, and **92**, and of first, second, and third tissue anchors **30**, **40**, and **42**, are to be understood only as convenient references to distinguish the sites and anchors from one another, and are not to be understood as implying or requiring any order of implantation or of other properties of the sites or anchors.)

[0217] For applications in which first venous tissue anchor **30** is implanted in superior vena cava **110** or inferior vena cava **80**, intraluminal stent **46** typically has a greatest outer diameter of between 25 and 55 mm, when unconstrained and fully radially expanded, i.e., no forces are applied to the stent by a delivery tool, walls of a blood vessel, or otherwise. For applications in which first venous tissue anchor **30** is implanted in coronary sinus **115**, intraluminal stent **46** typically has a greatest outer diameter of between 5 and 20 mm, when unconstrained and fully radially expanded (the stent may somewhat enlarge the coronary sinus).

[0218] Once pulley system **44** has been implanted, a size of a tricuspid orifice is reduced by tensioning tether **54**, so as to reduce regurgitation. For some applications in which second atrial tissue anchor **40** comprises tissue-coupling element **48A** and head **70**, as described hereinabove with reference to FIG. 1, tensioning tether **54** comprise fully extending pulley **50** away from head **70**, such that distance **D1**, described hereinabove, between (a) site **72** on pulley **50** farthest from head **70** and (b) site **74** on head **70** closest to pulley **50**, is at least 3 mm (e.g., at least 5 mm), no more than 40 mm, and/or between 3 and 40 mm or between 5 and 30 mm.

[0219] Pulley system **44** enables the controlled, uneven distribution of forces on tissue at first, second, and third implantation sites **89**, **90**, and **92**. As labeled in FIG. 1, a force vector **V1** on the tissue at second implantation site **90**, which is connected (e.g., permanently fixed) to pulley **50** by second atrial tissue anchor **40**, equals the vector sum of force vectors **V2** and **V3** acting on tissue at first and third implantation sites **89** and **92**, respectively, which are connected (e.g., permanently fixed) to tether **54** by first venous tissue anchor **30** and third atrial tissue anchor **42**, respectively. As a result, the forces acting on first and third implantation sites **89** and **92** are less than the force acting on second implantation site **90** (to which the pulley is fixed).

[0220] This controlled distribution of forces may be particularly beneficial if, for example:

[0221] second implantation site **90** (to which the pulley is fixed) is located in a region of tissue which is thicker or stronger than first and third implantation sites **89** and

92. For example, tissue of the septum between the ventricles is thicker and stronger than the atrium wall and the vena cava wall;

[0222] the anchoring mechanism of the anchor to which the pulley is connected anchors using mechanical purchase, e.g., using a helical anchor, while the anchoring mechanism of at least one of the other anchoring points (e.g., first implantation site **89**) is friction based, e.g., using an intraluminal stent; and/or

[0223] the force vectors acting on first implantation site **89** and second implantation site **90** (to which the pulley is fixed) are aligned along a preferable direction which causes constriction of the tricuspid valve in a more favorable manner than tensioning towards third implantation site **92** alone. For example, the sites may be selected apply the maximum force on the implantation site that is desired to be moved.

[0224] The tissue anchors and pulley system **44** are arranged such that the vector sum of the forces on all of the implantation sites is zero, and the force vector on second implantation site **90** (to which the pulley is fixed) is the vector sum of the forces acting on first and third implantation sites **89** and **92**. The scalar force acting on first and third implantation sites **89** and **92** depends on an angle α (alpha) (labeled in FIG. 1) formed by tether **54** at pulley **50**, and may be expressed by the following equation:

$$|F_s| = \frac{|F_p|}{2\cos(\frac{\alpha}{2})} \tag{Equation 1}$$

[0225] in which:

[0226] F_s is the force acting on each of the first and third implantation sites **89** and **92**;

[0227] F_p is the force acting on second implantation site **90** (to which the pulley is fixed); and

[0228] α (alpha) is the angle formed by tether **54** at pulley **50** (sometimes referred to in the pulley art as the “included angle”).

[0229] In accordance with this equation, the force acting on each of first and third implantation sites **89** and **92** is less than the force acting on second implantation site **90** (to which the pulley is fixed). The force acting on each of first and third implantation sites **89** and **92** is approximately 50% of the force acting on second implantation site **90** when angle α (alpha) is 45 degrees or less. (Angle α (alpha) is defined by two longitudinal portions **58A** and **58B** (labeled in FIG. 1) of tether **54** adjacent to and on opposite sides of pulley **50**.) For some applications, in order to achieve the desired force distribution among the implantation sites, when implanting the tissue anchors, the surgeon positions the tissue anchors and

pulley system **44** such that angle α (alpha) is acute (less than 90-degree), typically between 40 and 85 degrees, typically as close as possible to 45 degrees or lower.

[0230] For some applications in which pulley system **44** further comprises second tether **56**, a kit is provided that comprises a plurality of pulleys **50** connected (e.g., permanently fixed) to a respective plurality of second tissue anchors **40** by respective second tethers **56** having different respective lengths. The surgeon selects an appropriate pulley/second tether/second anchor assembly based on the particular anatomy of the subject, in order to achieve a desired angle α (alpha). The length of the second tether affects the location of the pulley. Alternatively, valve-tensioning implant system **20** comprises a single pulley, a single second tether, and a single second anchor, and the second tether has an adjustable length, which the surgeon can set before and/or during the implantation procedure as appropriate for the particular anatomy of the subject. Either option provides for an adjustable distance **D1**, as described hereinabove with reference to FIG. 1.

[0231] The following table sets forth exemplary combinations of first implantation site **89** and anatomical markers for second and third implantation sites **90** and **92**, and figures that show exemplary deployments at these sites. These sites are listed by way of example and not limitation; the surgeon typically selects the exact sites based on the subject’s individual needs and anatomy. Each of second and third implantation sites **90** and **92** is located within 1 cm of the site on the annulus that circumferentially corresponds to the respective anatomical marker (i.e., is at the same angular location or “o’clock” as the respective anatomical marker). The direction of the 1 cm from the site on the annulus may be either circumferentially (i.e., clockwise or counterclockwise) around the annulus, up the wall of right atrium **81** above annulus **83**, or a combination of circumferentially around the annulus and up the wall of the atrium. For example, as shown in FIG. 3B, anteroposterior commissure **112** is near, but not on, the annulus, and second tissue anchor **40** is shown implanted at second implantation site **90**, which is at the site on the annulus that circumferentially corresponds to this commissure. Second implantation site **90** could also be up to 1 cm clockwise or counterclockwise around the annulus from this site on the annulus, up to 1 cm up the wall of the atrium, or a combination of these two directions.

[0232] Typically, the surgeon uses the anatomical markers to find the exact locations of second and third implantation sites **90** and **92**, which are within 1 cm of the anatomical markers, as described above. For example, the commissures are easily detectable using imaging, and thus represent good anatomical markers. However, the commissures are not appropriate for implantation (because they are too delicate), so, in this example, the anchors are implanted on the annulus or up the wall of the atrium, within 1 cm from the commissure.

TABLE 1

	Second implantation site 90 (pulley)	Third implantation site	FIG.
First implantation site 89	anatomical marker	92 anatomical marker	
Inferior vena cava 80	Septoanterior commissure 114	Anteroposterior commissure 112	FIG. 3A
Inferior vena cava 80	Anteroposterior commissure 112	Septoanterior commissure 114	FIG. 3B

TABLE 1-continued

First implantation site 89	Second implantation site 90 (pulley) anatomical marker	Third implantation site 92 anatomical marker	FIG.
Inferior vena cava 80	A circumferential middle 93 of septal leaflet 82	Anteroposterior commissure 112	FIG. 3C
Inferior vena cava 80	Anteroposterior commissure 112	Circumferential middle 93 of septal leaflet 82	FIG. 3D
Superior vena cava 110	Anteroposterior commissure 112	Septoanterior commissure 114	FIG. 3E
Superior vena cava 110	Septoanterior commissure 114	Anteroposterior commissure 112	FIG. 3F
Superior vena cava 110	Anteroposterior commissure 112	Circumferential middle 93 of septal leaflet 82	FIG. 3G
Superior vena cava 110	Circumferential middle 93 of septal leaflet 82	Anteroposterior commissure 112	FIG. 3H
Inferior vena cava 80	A circumferential middle 121 of anterior leaflet 86	A circumferential middle 119 of posterior leaflet 84	FIG. 3I
Coronary sinus 115	Anteroposterior commissure 112	Septoanterior commissure 114	FIG. 3J
Coronary sinus 115	Septoanterior commissure 114	A septoposterior commissure 117	FIG. 3K
Inferior vena cava 80	Anteroposterior commissure 112	Coronary sinus 115	FIG. 3L
Superior vena cava 110	Anteroposterior commissure 112	Coronary sinus 115	FIG. 3M
Coronary sinus 115	Circumferential middle 121 of anterior leaflet 86	Circumferential middle 119 of posterior leaflet 84	FIG. 3N
Superior vena cava 110	Septoposterior commissure 117	Circumferential middle 121 of anterior leaflet 86	FIG. 3O

[0233] Thus, for some applications, an implantation method comprises implanting first venous tissue anchor 30 at first implantation site 89 in inferior vena cava 80. For some applications, second atrial tissue anchor 40 is implanted at second implantation site 90 which is located within 1 cm of a site on the annulus that circumferentially corresponds to circumferential middle 93 of septal leaflet 82 of tricuspid valve 78, and third atrial tissue anchor 42 is implanted at third implantation site 92 which is located within 1 cm of a site on the annulus that circumferentially corresponds to anteroposterior commissure 112 of tricuspid valve 78. Alternatively, for some applications, second atrial tissue anchor 40 is implanted at second implantation site 90 which is located within 1 cm of a site on the annulus that circumferentially corresponds to septoanterior commissure 114 of tricuspid valve 78, and third atrial tissue anchor 42 is implanted at third implantation site 92 which is located within 1 cm of a site on the annulus that circumferentially corresponds to anteroposterior commissure 112 of tricuspid valve 78.

[0234] Reference is again made to FIGS. 3L and 3M. For some applications, third tissue anchor 42 comprises a third venous tissue anchor, rather than an atrial tissue anchor. For these applications, third tissue anchor 42 typically comprises an intraluminal stent 146 that is configured to be implanted in coronary sinus 115. Intraluminal stent 146 typically has a greatest outer diameter of at least 10 mm, no more than 20 mm, and/or between 10 to 20 mm, when unconstrained and fully radially expanded. For some applications, the greatest outer diameter of intraluminal stent 146 is less than the greatest outer diameter of intraluminal stent 46, when both stents are unconstrained and fully radially expanded.

[0235] Reference is now made to FIG. 4, which is a schematic illustration of a valve-tensioning implant system 120, in accordance with an application of the present invention.

Other than as described hereinbelow, valve-tensioning implant system 120 is similar to, and may implement any of the features of, valve-tensioning implant system 20, described hereinabove with reference to FIGS. 1-3O. Valve-tensioning implant system 120 is configured to repair an atrioventricular valve of a subject (e.g., a tricuspid valve), using tension applied between multiple anchors of the implant. Typically, repair of the atrioventricular valve facilitates a reduction in atrioventricular valve regurgitation by altering the geometry of the atrioventricular valve and/or by altering the geometry of the wall of the right or left atrium of a heart of the subject.

[0236] For some applications, valve-tensioning implant system 120 comprises first venous tissue anchor 30, which is configured to be implanted in a vein selected from the group of veins consisting of: superior vena cava 110, inferior vena cava 80, and coronary sinus 115, such as described hereinbelow with reference to FIGS. 6A-I. First venous tissue anchor 30 may have any of the features described hereinabove with reference to FIG. 1.

[0237] Valve-tensioning implant system 120 further comprises a second atrial tissue anchor 140 and third atrial tissue anchor 42. For some applications, valve-tensioning implant system 120 comprises exactly two atrial tissue anchors, which consist of second and third atrial tissue anchors 140 and 42. Second atrial tissue anchor 140 comprises a head 170 and a tissue-coupling element 174. For some applications, head 170 is rotatable with respect to tissue-coupling element 174. Second and third atrial tissue anchors 140 and 42 may have any of the features of second and third atrial tissue anchors 40 and 42, described hereinabove with reference to FIG. 1.

[0238] Valve-tensioning implant system 120 further comprises a pulley system 144, which comprises (a) a pulley 150,

which is connected (e.g., permanently fixed) to second atrial tissue anchor **140**, and (b) tether **54** (described hereinabove with reference to FIG. 1), which is connected (e.g., permanently fixed) to first venous tissue anchor **30** and third atrial tissue anchor **42**, and is moveable through pulley **150**. Head **170** comprises pulley **150**. For some applications, head **170** comprises a tether interface **171**, which comprises pulley **150**. For some applications, tether interface **171** and/or pulley **150** are rotatable with respect to tissue-coupling element **174**. Such rotation may help reduce the torque applied to the atrial tissue by second atrial tissue anchor **140**. Furthermore, the rotation allows a biased friction, i.e., more friction towards the anchor point than towards the stent point, thus reducing the forces acting on the stent which is anchored in place using friction only, as compared to the helical tissue anchors, which use mechanical purchase.

[0239] In the configuration described with reference to FIGS. 4-61, tether **54** typically has a length, measured between first venous tissue anchor **30** and third atrial tissue anchor **42**, of at least 20 mm, no more than 200 mm, and/or between 20 and 200 mm, such as at least 30 mm, no more than 120 mm, and/or between 30 and 120 mm. The length equals the sum of (a) a first sub-length **L4** of a first portion of the tether between first venous tissue anchor **30** and pulley **150** and (b) a second sub-length **L5** of a second portion of the tether between pulley **150** and third atrial tissue anchor **42**. (First and second sub-lengths **L4** and **L5** are not fixed, because tether **54** is both moveable through pulley **50** as well as rotatable around the pivot point; however, the sum of the two sub-lengths is fixed.) Because tether **54** typically has a high tensile strength, the length thereof does not vary based on the particular disposition of the tether at any given point in time. In other words, the length of the tether does not depend on the amount of force applied to it. For some applications, as described hereinabove with reference to FIG. 1, tether **54** is configured so as to define anchor-fixing loop **66**, which passes through a corresponding interface (e.g., defined by struts of a stent) on first venous tissue anchor **30**, so as to connect (e.g., permanently fix) the tether to the first venous tissue anchor.

[0240] For some applications, as shown in FIG. 4, pulley **150** comprises an eyelet **172**, through which tether **54** is slidably moveable. Typically, a coefficient of kinetic friction between the tether and the eyelet is less than 0.5, such as less than 0.2, e.g., less than 0.1.

[0241] Reference is made to FIGS. 5A-B, which are schematic illustrations of two configurations of pulley **150**, in accordance with respective applications of the present invention. In these configurations, pulley **150** comprises a roller **176**, which is rotatable with respect to head **170**, and around which tether **54** passes. For some applications, such as shown in FIG. 5A, the roller axis is oriented parallel with a longitudinal axis of head **170**, while for other applications, such as shown in FIG. 5B, the roller axis is oriented perpendicular to the longitudinal axis of head **170**.

[0242] Reference is now made to FIGS. 6A-I, which are schematic illustrations of implantations of valve-tensioning implant system **120**, in accordance with respective applications of the present invention. The implantations are typically performed transvascularily, such as described hereinabove with reference to FIGS. 3A-O. First venous tissue anchor **30** is implanted at first site **89** in a vein selected from the group of veins consisting of: inferior vena cava **80** (as shown, for example, in FIGS. 6A-D), superior vena cava **110** (as shown, for example, in FIGS. 6E-G), and coronary sinus **115** (as

shown, for example, in FIGS. 6H-I). For applications in which first venous tissue anchor **30** comprises intraluminal stent **46**, the stent is expanded in the selected vein in order to anchor the stent to the wall of the vein by the outward radial force applied by the stent.

[0243] Second and third atrial tissue anchors **140** and **42**, e.g., exactly second and third atrial tissue anchors **140** and **42**, are implanted at respective different second atrial sites **190** and **192**, each of which sites is selected from the group of sites consisting of: annulus **83** of tricuspid valve **78**, and a wall of right atrium **81** above annulus **83**. For applications in which second and third atrial tissue anchors **140** and **42** comprise respective helical tissue-coupling elements **174** and **48B**, the helical tissue-coupling elements are rotated into tissue at the sites, respectively.

[0244] Pulley system **144** is implanted (including by implanting second atrial tissue anchor **140**). For applications in which intraluminal locking mechanism **55** is used, the male and female coupling elements thereof are locked together. A size of a tricuspid orifice is reduced by tensioning tether **54**, so as to reduce regurgitation.

[0245] (As used herein, including in the claims, the labels "first," "second," and "third" of first, second, and third sites **89**, **190**, and **192**, and of first, second, and third tissue anchors **30**, **40**, and **42**, are to be understood only as convenient references to distinguish the sites and anchors from one another, and are not to be understood as implying or requiring any order of implantation or of other properties of the sites or anchors.)

[0246] Pulley system **144** enables the controlled, uneven distribution of forces on tissue at first, second, and third implantation sites **89**, **190**, and **192**. As labeled in FIG. 4, a force vector **V4** on the tissue at second implantation site **190**, which is connected (e.g., permanently fixed) to pulley **150** by second tissue anchor **140**, equals the vector sum of force vectors **V5** and **V6** acting on tissue at first and third implantation sites **189** and **192**, respectively, which are connected (e.g., permanently fixed) to tether **54** by first venous tissue anchor **30** and third atrial tissue anchor **42**, respectively. (Force vectors **V4**, **V5**, and **V6** are not drawn to scale in FIG. 4.) As a result, the forces acting on first and third implantation sites **89** and **192** are less than the force acting on second implantation site **190** (to which the pulley is fixed).

[0247] This controlled distribution of forces may be particularly beneficial if, for example:

[0248] second implantation site **190** (to which the pulley is fixed) is located in a region of tissue which is thicker or stronger than first and/or third implantation sites **89** and **192**. For example, tissue of the septum between the ventricles is thicker and stronger than the atrium wall and the vena cava wall;

[0249] the anchoring mechanism of the anchor to which the pulley is not fixed performs anchoring using mechanical purchase, e.g., using a helical anchor, while the anchoring mechanism of another of the anchors the (e.g., at first implantation site **89**) is friction based, e.g., using an intraluminal stent; and/or

[0250] the force vectors acting on first implantation site **89** and second implantation site **190** (to which the pulley is fixed) are aligned along a preferable direction which causes constriction of the tricuspid valve in a more favorable manner than tensioning towards third implantation site **192** alone. For example, the sites may be

selected apply the maximum force on the implantation site that is desired to be moved.

[0251] The tissue anchors and pulley system 144 are arranged such that the vector sum of the forces on all of the

may be either circumferentially around the annulus, up the wall of right atrium 81 above annulus 83, or a combination of circumferentially around the annulus and up the wall of the atrium.

TABLE 2

First implantation site 89	Second implantation site 190 (pulley) anatomical marker	Third implantation site 192 anatomical marker	FIG.
Inferior vena cava 80	Circumferential middle 93 of septal leaflet 82	Anteroposterior commissure 112	FIG. 6A
Inferior vena cava 80	Anteroposterior commissure 112	Circumferential middle 93 of septal leaflet 82	FIG. 6B
Inferior vena cava 80	Circumferential middle 119 of posterior leaflet 84	Septoanterior commissure 114	FIG. 6C
Inferior vena cava 80	Septoanterior commissure 114	Circumferential middle 119 of posterior leaflet 84	FIG. 6D
Superior vena cava 110	Circumferential middle 121 of anterior leaflet 86	Circumferential middle 119 of posterior leaflet 84	FIG. 6E
Superior vena cava 110	Anteroposterior commissure 112	Coronary Sinus 115	FIG. 6F
Superior vena cava 110	Circumferential middle 119 of posterior leaflet 84	Circumferential middle 121 of anterior leaflet 86	FIG. 6G
Coronary Sinus 115	Anteroposterior commissure 112	Septoanterior commissure 114	FIG. 6H
Coronary Sinus 115	Circumferential middle 121 of anterior leaflet 86	Circumferential middle 119 of posterior leaflet 84	FIG. 6I

implantation sites is zero, and the force vector on second implantation site 190 (to which the pulley is fixed) is the vector sum of the forces acting on first and third implantation sites 89 and 192. The scalar force acting on first and third implantation sites 89 and 192 depends on an angle β (beta) (labeled in FIG. 4) formed by tether 54 at pulley 150, and may be expressed by Equation 1, described above with reference to FIG. 1, mutatis mutandis.

[0252] In accordance with this equation, the force acting on each of first and third implantation sites 89 and 192 is equal to the force acting on second implantation site 190 when the angle is 120 degrees, and increases as the angle increases, to approximately 46% greater than the force acting on second implantation site 190 when the angle is 140 degrees. (Angle β (beta) is defined by two longitudinal portions 58A and 58B (labeled in FIG. 4) of tether 54 adjacent to and on opposite sides of pulley 150.) For some applications, in order to achieve the desired force distribution among the implantation sites, when implanting the tissue anchors, the surgeon positions the tissue anchors and pulley system 144 such that angle β (beta) is between 120 and 180 degrees, such as between 135 and 175 degrees, typically as close as possible to 180 degrees, which will result in zero force on the pulley point (although achieving 180 degrees is difficult, if not impossible, in practice).

[0253] The following table sets forth exemplary combinations of first implantation site 89 and anatomical markers for second and third implantation sites 190 and 192, and figures that show exemplary deployments at these sites. These sites are listed by way of example and not limitation; the surgeon typically selects the exact sites based on the subject's individual needs and anatomy. Each of second and third implantation sites 190 and 192 is located within 1 cm of the site on the annulus that circumferentially corresponds to the respective anatomical marker. The direction of the 1 cm from the site

[0254] Thus, for some applications, an implantation method comprises implanting first venous tissue anchor 30 at first implantation site 89 in inferior vena cava 80. For some applications, second atrial tissue anchor 140 is implanted at second implantation site 190 which is located within 1 cm of a site on the annulus that circumferentially corresponds to circumferential middle 93 of septal leaflet 82 of tricuspid valve 78, and third atrial tissue anchor 42 is implanted at third implantation site 192 which is located within 1 cm of a site on the annulus that circumferentially corresponds to anteroposterior commissure 112 of tricuspid valve 78.

[0255] Reference is now made to FIG. 7, which is a schematic illustration of a valve-tensioning implant system 220, in accordance with an application of the present invention. Other than as described hereinbelow, valve-tensioning implant system 220 is similar to, and may implement any of the features of, valve-tensioning implant system 20, described hereinabove with reference to FIGS. 1-30. Valve-tensioning implant system 220 is configured to repair an atrioventricular valve of a subject (e.g., a tricuspid valve), using tension applied between multiple anchors of the implant. Typically, repair of the atrioventricular valve facilitates a reduction in atrioventricular valve regurgitation by altering the geometry of the atrioventricular valve and/or by altering the geometry of the wall of the right or left atrium of a heart of the subject.

[0256] For some applications, valve-tensioning implant system 220 comprises first venous tissue anchor 30, which is configured to be implanted in a vein selected from the group of veins consisting of: superior vena cava 110, inferior vena cava 80, and coronary sinus 115. First venous tissue anchor 30 may have any of the features described hereinabove with reference to FIG. 1.

[0257] Valve-tensioning implant system 220 further comprises second and third atrial tissue anchors 40 and 42. For

some applications, valve-tensioning implant system **220** comprises exactly two atrial tissue anchors, which consist of second and third atrial tissue anchors **40** and **42**. Second and third atrial tissue anchors **40** and **42** may have any of the features of second and third atrial tissue anchors **40** and **42**, described hereinabove with reference to FIG. 1.

[0258] Valve-tensioning implant system **220** further comprises a pulley system **244**, which comprises:

[0259] a pulley **250**, which is connected (e.g., permanently fixed) to first venous tissue anchor **30**;

[0260] a first tether **254**, which (a) is connected (e.g., permanently fixed) to second and third atrial tissue anchors **40** and **42**, (b) is moveable through pulley **250**, and/or the pulley is rotatable around a pivot point, and (c) has a first length, measured between the second and the third atrial tissue anchors, of at least 10 mm, e.g., at least 15 mm, such as at least 20 mm, no more than 50 mm, and/or between 20 and 50 mm, or between 15 and 30 mm; and

[0261] a second tether **256**, which (a) is connected (e.g., permanently fixed) to first venous tissue anchor **30** and to pulley **250**, and (b) has a second length **L6**, measured between first venous tissue anchor **30** and pulley **250**, equal to at least 80% (e.g., at least 100%) of the first length, of at least 25 mm (e.g., at least 30 mm), no more than 180 mm, and/or between 25 mm (e.g., 30 mm) and 180 mm, e.g., no more than 120 mm and/or between 30 and 120 mm.

[0262] First and second tethers **254** and **256** comprise respective elongate flexible elements, such as cords, sutures, or bands. The tethers are typically sufficiently flexible for twisting or bending but are inelastic against tension. Typically, first and second tethers **254** and **256** have a high tensile strength, in order to enable the tethers to apply tension, as described hereinbelow.

[0263] The first length equals the sum of (a) a first sub-length **L7** of a first portion of first tether **254** between second atrial tissue anchor **40** and pulley **250** and (b) a second sub-length **L8** of a second portion of first tether **254** between pulley **250** and third atrial tissue anchor **42**. (First and second sub-lengths **L7** and **L8** are not fixed, because tether **54** is both moveable through pulley **50** as well as rotatable around the pivot point; however, the sum of the two sub-lengths is fixed.) Because the first and the second tethers typically have a high tensile strength, the lengths thereof do not vary based on the particular disposition of the first and the second tethers at any given point in time. In other words, the lengths of the tethers do not depend on the amount of force applied to them.

[0264] For some applications, the second length **L6** equals at least 100% of the first length.

[0265] For some applications, second tether **256** is configured so as to define an anchor-fixing loop **266**, which passes through a corresponding interface (e.g., defined by struts of the stent) on first venous tissue anchor **30**, so as to connect (e.g., permanently fix) the second tether to the first venous tissue anchor. For some applications, first tether **254** is configured so as to define one or both of anchor-fixing loops **268A** and **268B**, which pass through corresponding interfaces on second and third atrial tissue anchors **40** and **42**, respectively, so as to connect (e.g., permanently fix) the first tether to the second and third atrial tissue anchors, respectively.

[0266] For some applications, tether **256** comprises two separate sections **256A** and **256B**, which may be connected

by intraluminal locking mechanism **55**, described hereinabove with reference to FIG. 1.

[0267] For some applications, as shown in FIG. 7, pulley **250** comprises a loop **252**, through which first tether **254** is slidably moveable. Typically, a coefficient of kinetic friction between the first tether and the loop is less than 0.5, such as less than 0.2, e.g., less than 0.1. For some applications, as shown in FIG. 7, loop **252** comprises a closed loop; in other words, the ends of the loop are joined together. For other applications (not shown), loop **252** comprises an open loop; both ends of the cord that defines the loop are connected (e.g., permanently fixed) to first venous tissue anchor **30**, but not to one another. In other words, pulley **250** comprises a flexible longitudinal member that is connected (e.g., permanently fixed) to the first venous tissue anchor **30** at two points along the flexible longitudinal member, so as to define loop **252** longitudinally between the two points.

[0268] For some applications, such as shown in FIG. 2C, described hereinabove, pulley **250** comprises ring **60**, through which first tether **254** is slidably moveable. Typically, a coefficient of kinetic friction between first tether **254** and ring **60** is less than 0.5, such as less than 0.2, e.g., less than 0.1. For other applications, such as shown in FIG. 2D, described hereinabove, pulley **250** comprises wheel **62** on an axle that supports movement of first tether **254** along the wheel's circumference. Wheel **62** typically is shaped so as to define a groove between two flanges around its circumference, as is well-known in the pulley art. Pulley **250** may alternatively comprise an eyelet or a roller, such as described hereinabove with reference to FIGS. 4 and 5A-B.

[0269] Reference is now made to FIGS. 8A-H, which are schematic illustrations of implantations of valve-tensioning implant system **220**, in accordance with respective applications of the present invention. The implantations are typically performed transvascularily, such as described hereinabove with reference to FIGS. 3A-O. First venous tissue anchor **30** is implanted at first site **89** in a vein selected from the group of veins consisting of: superior vena cava **110** (as shown, for example, in FIGS. 8C-D), inferior vena cava **80** (as shown, for example, in FIGS. 8A-B and 8H), and coronary sinus **115**, as shown, for example, in FIGS. 8E-G). For applications in which first venous tissue anchor **30** comprises intraluminal stent **46**, the stent is expanded in the selected vein in order to anchor the stent to the wall of the vein by the outward radial force applied by the stent.

[0270] Second and third atrial tissue anchors **40** and **42**, e.g., exactly second and third atrial tissue anchors **40** and **42**, are implanted at respective different second atrial sites **290** and **292**, each of which sites is selected from the group of sites consisting of: annulus **83** of tricuspid valve **78**, and a wall of right atrium **81** above annulus **83**. For applications in which second and third atrial tissue anchors **40** and **42** comprise respective helical tissue-coupling elements **48A** and **48B**, the helical tissue-coupling elements are rotated into tissue at the sites, respectively.

[0271] Pulley system **244** is implanted, locking mechanism **55**, if provided, is attached, and a size of a tricuspid orifice is reduced by tensioning second tether **256**, which also tensions first tether **254**, so as to reduce regurgitation. FIG. 8A shows the pulley system before the locking mechanism has been attached and the tethers have been tensioned, and FIG. 8B shows the pulley system after the locking mechanism is attached and the tethers have been tensioned.

[0272] (As used herein, including in the claims, the labels “first,” “second,” and “third” of first, second, and third sites 89, 290, and 292, and of first, second, and third tissue anchors 30, 40, and 42, are to be understood only as convenient references to distinguish the sites and anchors from one another, and are not to be understood as implying or requiring any order of implantation or of other properties of the sites or anchors.)

[0273] Pulley system 244 enables the controlled, uneven distribution of forces on tissue at first, second, and third implantation sites 89, 290, and 292. As labeled in FIG. 7, a force vector V7 on the tissue at first implantation site 89, which is connected (e.g., permanently fixed) to pulley 250 by first venous tissue anchor 30, equals the vector sum of force vectors V8 and V9 acting on tissue at second and third implantation sites 290 and 292, respectively, which are connected (e.g., permanently fixed) to first tether 254 by second and third atrial tissue anchors 40 and 42, respectively. As a result, the forces acting on first implantation site 89 (to which the pulley is fixed) is less than the forces acting on second and third implantation site 290 and 292.

[0274] This controlled distribution of forces may be particularly beneficial if, for example:

[0275] second implantation site 290 or third implantation site 292 is located in a region of tissue which is thicker or stronger than first implantation site 89. For example, tissue of the septum between the ventricles is thicker and stronger than the vena cava wall;

[0276] the anchoring mechanism of second and third atrial tissue anchors 40 and 42 anchors using mechanical purchase, e.g., using a helical anchor, while the anchoring mechanism of first venous tissue anchor 30 at first implantation site 89 is friction based, e.g., using an intraluminal stent; and/or

[0277] the force vectors acting on second and third implantation sites 290 and 292 are aligned along a preferable direction which causes constriction of the tricuspid valve in a more favorable manner than tensioning towards first implantation site 89. For example, the sites may be selected apply the maximum force on the implantation site that is desired to be moved.

[0278] The tissue anchors and pulley system 244 are arranged such that the vector sum of the forces on all of the implantation sites is zero, and the force vector on first implantation site 89 (to which the pulley is fixed) is the vector sum of the forces acting on second and third implantation sites 190 and 192. The scalar force acting on second and third implantation sites 190 and 192 depends on an angle γ (gamma) (labeled in FIG. 7) formed by first tether 254 at pulley 250, and may be expressed by Equation 1, described above with reference to FIG. 1, mutatis mutandis.

[0279] In accordance with this equation, the force acting on first implantation site 89 (to which the pulley is fixed) is less than each of the forces acting on second and third implantation sites 290 and 292; at an angle γ (gamma) of 120 degrees, all forces are approximately equal. As the angle increases and approximates 180 degrees, the force on first implantation site 89 is reduced to almost zero, although such an angle is not achievable in practice. For example, when angle γ (gamma) is 140 degrees, the force at first implantation site 89 is only approximately 68% of the force acting on each of second and third implantation sites 190 and 192. When the angle is 160 degrees, the force at first implantation site 89 is further

reduced to approximately 35% of the force acting on each of second and third implantation sites 190 and 192.

[0280] For some applications, in order to achieve the desired force distribution among the implantation sites, when implanting the tissue anchors, the surgeon positions the tissue anchors and pulley system 144 such that two longitudinal portions 258A and 258B (labeled in FIG. 7) of first tether 254 adjacent to and on opposite sides of pulley 250 define an angle γ (gamma) therebetween, typically of between 120 and 180 degrees, such as between 135 and 175 degrees, typically as close as possible to 180 degrees.

[0281] The following table sets forth exemplary combinations of first implantation site 89 and anatomical markers for second and third implantation sites 290 and 292, and figures that show exemplary deployments at these sites. These sites are listed by way of example and not limitation; the surgeon typically selects the exact sites based on the subject’s individual needs and anatomy. Each of second and third implantation sites 290 and 292 is located within 1 cm of the site on the annulus that circumferentially corresponds to the respective anatomical marker. The direction of the 1 cm from the site may be either circumferentially around the annulus, up the wall of right atrium 81 above annulus 83, or a combination of circumferentially around the annulus and up the wall of the atrium.

TABLE 3

First implantation site 89 (pulley)	Second implantation site 290 anatomical marker	Third implantation site 292 anatomical marker	FIG.(s)
Inferior vena cava 80	Anteroposterior commissure 112	Circumferential middle 93 of septal leaflet 82	FIGS. 8A and 8B
Superior vena cava 110	Anteroposterior commissure 112	Septoanterior commissure 114	FIG. 8C
Inferior vena cava 80	Circumferential middle 93 of septal leaflet	Septoanterior commissure 114	FIG. 8H
Superior vena cava 110	Circumferential middle 93 of septal leaflet 82	Anteroposterior commissure 112	FIG. 8D
Coronary sinus 115	Anteroposterior commissure 112	Septoposterior commissure 117	FIG. 8E
Coronary sinus 115	Circumferential middle 93 of septal leaflet 82	Anteroposterior commissure 112	FIG. 8F
Coronary sinus 115	Circumferential middle 121 of anterior leaflet 86	Circumferential middle 119 of posterior leaflet 84	FIG. 8G

[0282] Thus, for some applications, an implantation method comprises implanting first venous tissue anchor 30 at first implantation site 89 in inferior vena cava 80. For some applications, second atrial tissue anchor 40 is implanted at second implantation site 290 which is located within 1 cm of a site on the annulus that circumferentially corresponds to anteroposterior commissure 112. For some applications, third atrial tissue anchor 42 is implanted at third implantation site 292 which is located within 1 cm of a site on the annulus that circumferentially corresponds to septoanterior commissure 114. Alternatively, for some applications, third atrial tissue anchor is implanted at third implantation site 292 which is located within 1 cm of a site on the annulus that circumferentially corresponds to circumferential middle 93 of septal leaflet 82.

[0283] For other applications, the implantation method comprises implanting first venous tissue anchor 30 at first implantation site 89 in superior vena cava 110. For some applications, third atrial tissue anchor 42 is implanted at third

implantation site **292** which is located within 1 cm of a site on the annulus that circumferentially corresponds to anteroposterior commissure **112**. For some applications, second atrial tissue anchor **40** is implanted at second implantation site **290** which is located within 1 cm of a site on the annulus that circumferentially corresponds to septoanterior commissure **114**. Alternatively, for some applications, second atrial tissue anchor **40** is implanted at second implantation site **290** which is located within 1 cm of a site on the annulus that circumferentially corresponds to circumferential middle **93** of septal leaflet **82**.

[0284] For still other applications, the implantation method comprises implanting first venous tissue anchor **30** at first implantation site **89** in the coronary sinus. For some applications, third atrial tissue anchor **42** is implanted at third implantation site **292** which is located within 1 cm of a site on the annulus that circumferentially corresponds to anteroposterior commissure **112**. For some applications, second atrial tissue anchor **40** is implanted at second implantation site **290** which is located within 1 cm of a site on the annulus that circumferentially corresponds to septoanterior commissure **114**. Alternatively, for some applications, second atrial tissue anchor **40** is implanted at second implantation site **290** which is located within 1 cm of a site on the annulus that circumferentially corresponds to of circumferential middle **93** of septal leaflet **82**.

[0285] Reference is again made to FIGS. 1-4H and 7-8H. For some applications, a valve-tensioning implant system **20**, **220** is provided, which comprises first, second, and third tissue anchors **30**, **40**, and **42**. For some applications, the valve-tensioning implant comprises exactly three tissue anchors, which consist of first, second, and third tissue anchors **30**, **40**, and **42**. First tissue anchor **30** is not necessarily a venous tissue anchor.

[0286] Valve-tensioning implant system **20**, **220** further comprises pulley system **44**, **244**, which comprises:

[0287] pulley **50**, **250**;

[0288] first tether **54**, **254**, which (a) is connected (e.g., permanently fixed) to second and third tissue anchors **40** and **42**, (b) is moveable through pulley **50**, **250**, and (c) has a first length, measured between second and third tissue anchors **40** and **42**, of at least 15 mm; and

[0289] second tether **56**, **256**, which (a) is connected (e.g., permanently fixed) to first tissue anchor **30** and to pulley **50**, **250**, and (b) has a second length, measured between first tissue anchor **30** and pulley **50**, **250**, of at least 15 mm.

[0290] Reference is now made to FIGS. 9A and 9B, which are schematic illustrations of a delivery system comprising a multiple-anchor delivery tool **300**, in accordance with respective applications of the present invention. Multiple-anchor delivery tool **300** is used to sequentially deliver and implant two or more tissue anchors of an implant **310**.

[0291] Implant **310** comprises:

[0292] at least first and second tissue anchors **340** and **342**, which comprise (a) first and second helical tissue-coupling elements **48A** and **48B**, respectively, and (b) first and second heads **370A** and **370B**, respectively, which comprise first and second tether interfaces **380A** and **380B**; and

[0293] a tether **382**, which is connected (e.g., permanently fixed) to first tether interface **380A**, and coupled to second tether interface **380B** (optionally slidably

coupled to second tether interface **380B**, such that the tether slidably passes through the second tether interface).

[0294] For some applications, first tissue anchor **340** comprises second tissue anchor **40**, second tissue anchor **140**, or third tissue anchor **42**, described hereinabove. Alternatively or additionally, for some applications, second tissue anchor **342** comprises second tissue anchor **40**, second tissue anchor **140**, or third tissue anchor **42**, described hereinabove. For some applications, first tether interface **380A** is rotatable with respect to first tissue-coupling element **48A**, and/or second tether interface **380B** is rotatable with respect to first tissue-coupling element **48B**.

[0295] For some applications, implant **310** comprises a male coupling **480** of a first flexible-longitudinal-member-coupling element **482** of an intraluminal locking mechanism **484** which is connected to a female coupling during the implantation procedure, such as in order to allow implantation of the third tissue anchor with a separate catheter delivery system, such as described in above-mentioned US Patent Application Publication 2013/0018459, for example with reference to FIGS. 25-26 thereof.

[0296] For some applications, as shown in FIG. 9B, implant **310** comprises pulley **250**, described hereinabove with reference to FIGS. 7-8H. The pulley may be connected to first flexible-longitudinal-member-coupling element **482**. Although pulley **250** is shown comprising ring **60**, described hereinabove with reference to FIG. 2C, the pulley may alternatively comprise another of the pulleys described herein, including those described with reference to FIG. 2A or 2D.

[0297] Multiple-anchor delivery tool **300** comprises a catheter shaft **400** having proximal and distal ends **410** and **412**. First and second tissue anchors **340** and **342** are initially removably positioned in catheter shaft **400** at first and second longitudinal locations **414** and **416**, respectively. First longitudinal location **414** is more distal than second longitudinal location **416**. In other words, the tissue anchors are initially positioned in the desired sequence of deployment in the catheter shaft, with the first anchor to be deployed positioned more distally than the subsequent anchor(s) to be deployed. The tissue anchors are interconnected by tether **382**.

[0298] Multiple-anchor delivery tool **300** further comprises first and second torque cables **420** and **422**, which (a) are removably coupled to first and second heads **370A** and **370B**, respectively, (b) extend within catheter shaft **400** proximally from first and second heads **370A** and **370B**, respectively, and (c) transmit torque when rotated, for rotating tissue-coupling elements **48A** and **48B**, respectively, into tissue. Typically, the torque cables additionally transmit axial force, to enable pushing of the tissue-coupling elements **48A** and **48B** into the tissue as they are rotated. A portion **430** of first torque cable **420** is initially removably positioned alongside second tissue anchor **342** in catheter shaft **400**. Thus each anchor is separately connected to a control handle **470** by its own torque cable, which allows full and separate control of deployment of each anchor by an operator of the multiple-anchor delivery tool.

[0299] For some applications, implant **310** comprises one or more additional tissue anchors, and tool **300** correspondingly comprises one or more additional torque cables, removably coupled to the tissue-coupling elements, as described herein. These additional tissue anchors are initially removably positioned in catheter shaft **400** proximal to second longitudinal location **416**. For example, implant **310** may

further comprise a third tissue anchor, which comprises (a) a third helical tissue-coupling elements, and (b) a third head, which comprises a third tether interface; the tether is coupled to (e.g., slidably coupled to) the third tether interface; the third tissue anchor is removably positioned in catheter shaft **400** at a third longitudinal location that is more proximal than second longitudinal location **416**; and multiple-anchor delivery tool **300** further comprises a third torque cable, which (a) is removably coupled to the third head, (b) extends within the catheter shaft proximally from the third head, and (c) transmits torque when rotated, wherein a portion of the second torque cable is removably positioned alongside the third tissue anchor in the catheter shaft.

[0300] For some applications, first torque cable **420** is shaped so as to define a lumen **440** therethrough, and multiple-anchor delivery tool **300** further comprises a sharpened wire **442**, which removably passes through lumen **440**. A distal end of first torque cable **420** comprises a distal coupling element **450**, which is configured to be removably coupled to a corresponding proximal coupling element **452** defined by a proximal portion of first head **370A**. Distal and proximal coupling elements **450** and **452** are shaped so as to define corresponding interlocking surfaces, such that the coupling elements interlock, thereby mating the coupling elements to one another. Head **370A**, including proximal coupling element **452**, is shaped so as to define a first longitudinal channel **456** at least partially therethrough (typically entirely therethrough), which channel is coaxial with head **370A**. Distal coupling element **450** is shaped so as to define a second longitudinal channel **458** therethrough, which is coaxial with lumen **440** of first torque cable **420**. First and second channels **456** and **458** are radially aligned with one another. When a portion of sharpened wire **442** is positioned in these channels, the sharpened wire prevents decoupling of distal coupling element **450** from proximal coupling element **452**. Upon removal of sharpened wire **442** from channels **456** and **458** and the coupling elements **450** and **452**, the coupling elements are free to be decoupled from one another.

[0301] For some applications, sharpened wire **442** is shaped so as to define a sharp distal tip **460**. For these applications, first tissue-coupling element **48A** typically is helical, and sharpened wire **442** is initially removably positioned within a channel defined by the helix. As tissue-coupling element **48A** is screwed into tissue, sharpened wire **442** penetrates and advances into the tissue along with the anchor to a certain depth in the tissue. For some applications, when the shaft penetrates to the certain depth, the sharpened wire is withdrawn slightly. Typically, after tissue-coupling element **48A** has been fully implanted, sharpened wire **442** is withdrawn entirely from the tissue, and removed from the patient's body. Optionally, the sharp distal tip of sharpened wire **442** is inserted into the tissue slightly, even before insertion of tissue-coupling element **48A**, in order to prevent sliding of the tissue-coupling element on the surface of the tissue before commencement of insertion of the tissue-coupling element into the tissue.

[0302] After implantation of tissue-coupling element **48A**, sharpened wire **442** is withdrawn proximally from the channel of tissue-coupling element **48A** and from channels **456** and **458** of distal and proximal coupling elements **450** and **452**, thereby decoupling the coupling elements from one another, and decoupling first torque cable **420** from head **370A**. After such proximal withdrawal, sharpened wire **442** typically remains within lumen **440** of first torque cable **420**.

[0303] For some applications, the decoupling of first torque cable **420** and head **370A** is performed alternatively or additionally using techniques described in US Patent Application Publication 2012/0035712, which is assigned to the assignee of the present application and is incorporated herein by reference, such as with reference to FIGS. **12A-C** thereof.

[0304] Second torque cable **422** and second tissue anchor **342** similarly comprise the above-mentioned elements (e.g., the sharpened wire and coupling elements), and are similarly configured, as do any additional torque cables and tissue anchors that may be provided, as described above.

[0305] Multiple-anchor delivery tool **300** further comprises control handle **470**, which is configured to control the deployment of the tissue anchors, by rotating the torque cables, distally advancing the anchors through catheter shaft **400**, and proximally withdrawing the sharpened wire and torque cables. Control handle **470** may implement features of handle portion **1004**, described with reference to FIG. **11C** of above-mentioned US Patent Application Publication 2012/0035712, *mutatis mutandis*.

[0306] Reference is now made to FIGS. **10A-C**, which are schematic illustrations of a deployment method using multiple-anchor delivery tool **300**, in accordance with an application of the present invention. This method may be used to deploy second tissue anchor **40**, second tissue anchor **140**, and/or third tissue anchor **42**, described hereinabove, or other tissue anchors. Although FIGS. **10A-C** illustrate the implantation of the configuration of implant **310** shown in FIG. **9B**, the same techniques can be used for the implantation of the configuration shown in FIG. **9A**. Catheter shaft **400** is typically advanced transvascularily, using a delivery system comprising one or more catheters introduced with the aid of a guidewire, through vasculature of the subject, such as (a) via the femoral vein, through inferior vena cava **80**, and into a right atrium **81**, (b) via the basilic vein, through the subclavian vein through superior vena cava **110**, and into right atrium **81**, or (c) via the external jugular vein, through the subclavian vein through superior vena cava **110**, and into right atrium **81**. The procedure is typically performed with the aid of imaging, such as fluoroscopy, transesophageal echo, and/or echocardiography. The procedure may be performed using techniques described in US Patent Application Publication 2012/0035712, which is assigned to the assignee of the present application and is incorporated herein by reference, with reference to FIGS. **1A-D** thereof, *mutatis mutandis*.

[0307] Distal end **412** of catheter shaft **400** of multiple-anchor delivery tool **300** is advanced into the body of a subject, while (a) first and second tissue anchors **340** and **342** are removably positioned in catheter shaft **400** at first and second longitudinal locations **414** and **416**, respectively, first longitudinal location **414** more distal than second longitudinal location **416**. Portion **430** of first torque cable **420** is removably positioned alongside second tissue anchor **342** in catheter shaft **400**. Thus, catheter shaft **400** does not need to be withdrawn and reintroduced from the body during the implantation procedure.

[0308] As shown in FIG. **10A**, first tissue anchor **340** is implanted into tissue **500** of the subject (e.g., cardiac muscle tissue, such as atrial tissue) by rotating first torque cable **420**, using control handle **470**, and, typically pushing distally on the torque cable.

[0309] As shown in FIG. **10B**, after first tissue anchor **340** has been fully implanted in tissue **500**, first torque cable **420** is decoupled from first tissue anchor **340**, such as by proxi-

mally withdrawing sharpened wire **442**, as described hereinabove with reference to FIGS. **9A-B**. First torque cable **420** is typically further proximally withdrawn in catheter shaft **400** (not shown), and optionally withdrawn out of the proximal end of the catheter shaft.

[**0310**] As shown in FIG. **10C**, after first tissue anchor **340** is implanted, second tissue anchor **342** is distally advanced in catheter shaft **400**, and implanted into tissue **500** by rotating second torque cable **422**. The second torque cable is decoupled from second tissue anchor **342** (not shown). First and second tissue anchors **340** and **342** remain implanted in tissue **500**, connected by tether **382**, with the pulley freely movable on it.

[**0311**] Pulley **250**, which extends distally from second tether interface **380B**, may be tensioned so as to apply tension between the first and the second tissue anchors, as described hereinabove with reference to FIGS. **8A-H**. For example, pulley **250** may be removably connected to a flexible longitudinal guide member **390** by first flexible-longitudinal-member-coupling element **482**, which may be coupled to the female part of the locking mechanism using a separate catheter delivery system containing first venous tissue anchor **30**, such as described in above-mentioned US Patent Application Publication 2013/0018459, for example with reference to FIGS. **23-26** thereof, *mutatis mutandis* (in which flexible longitudinal guide member **2616** corresponds to flexible longitudinal guide member **390** of the present application).

[**0312**] Reference is now made to FIGS. **11A-D**, which are schematic illustrations of a delivery system comprising multiple-anchor delivery tools **600A**, **600B**, **600C**, and **600D**, respectively, in accordance with respective applications of the present invention. Multiple-anchor delivery tools **600** are used to sequentially deliver and implant one or more helical tissue anchors **640** and an intraluminal stent anchor **646** of an implant, such as one of the implants described hereinabove. As described below, multiple-anchor delivery tools **600** may be used alone or in combination with multiple-anchor delivery tool **300**, described hereinabove with reference to FIGS. **9A-B**.

[**0313**] Each of multiple-anchor delivery tools **600** typically comprises an inner stent-deployment shaft **650**, a distal tubular tip element **652**, an outer shaft **654**, and an outer delivery catheter **656**. Stent anchor **646** is initially removably disposed surrounding a longitudinal portion of inner stent-deployment shaft **650** and within distal tubular tip element **652**. With the stent anchor thus positioned, distal tubular tip element **652** is pushed into coronary sinus **115**. Distal advancement of distal tubular tip element **652** with respect to inner stent-deployment shaft **650** releases stent anchor **646**, which typically self-expands upon release. For example, the distal tubular tip element may be advanced distally by distally advancing a pusher rod **658** that passes through a channel of inner stent-deployment shaft **650** and is coupled to the distal tubular tip element (typically to a distal end thereof, within the tip element). Inner stent-deployment shaft **650** is slidably disposed within a channel of outer shaft **654**, which itself is advanceable within a channel of outer delivery catheter **656**. As shown in FIG. **11C**, pusher rod **658** and a distal portion of tip element **652** typically are shaped so as to define a channel there-through, through which a guidewire **670** passes.

[**0314**] Reference is made to FIG. **11A**. Multiple-anchor delivery tool **600A** is configured to deploy a helical tissue anchor **640** and stent anchor **646**. Multiple-anchor delivery tool **600A** is capable of deploying either the helical tissue

anchor or the stent anchor first. Helical tissue anchor **640** is deployed using an anchor-deployment shaft **660**, which passes through outer shaft **654**, and typically exits the outer shaft through a lateral opening **662**. Stent anchor **646** and helical tissue anchor **640** are tensioned to a stent venous tissue anchor (such as first venous tissue anchor **30**) in SVC **110** or IVC **80**, such as described hereinabove with reference to FIGS. **3L** and **3M** (the configuration described with reference to FIG. **6F** is also similar). For some applications, multiple-anchor delivery tool **600A** is used as described hereinbelow with reference to FIGS. **12A-C**.

[**0315**] Reference is made to FIG. **11B**. Multiple-anchor delivery tool **600B** is configured to deploy a female coupling element **680** and stent anchor **646**. Stent anchor delivery tool **600B** is capable of deploying stent anchor and connecting it to the male locking mechanism of multiple anchor deploying system such as described in FIG. **9A**. Female coupling element **680** is deployed using shaft **660**, which passes through outer shaft **654**, and typically exits the outer shaft through a lateral opening **662**. The stent anchor and the female coupling element are tethered together by a textile band. Female coupling element **680** may be connected to a male coupling element during the implantation procedure. The female and male coupling elements may be components of intraluminal locking mechanism **55**, described hereinabove with reference to FIGS. **1**, **3A-O**, **4**, **6A-I**, **7**, and **8A-H**. The male and female coupling elements may be connected using techniques described in US Patent Application Publication 2013/0018459, such as with reference to FIGS. **20-32** thereof. Female coupling element **680** is then used to tether the first two helical tissue anchors, such as described hereinabove with reference to FIG. **9A**, to a coronary sinus stent. The coronary sinus stent is then pushed forward into the coronary stent, thereby tensioning the tether system.

[**0316**] Reference is made to FIG. **11C**. Multiple-anchor delivery tool **600C** is configured to deploy two helical tissue anchors **640A** and **640B**, and stent anchor **646**. Typically, multiple-anchor delivery tool **600C** first deploys the two helical tissue anchors, using respective anchor-deployment shafts **660A** and **660B**, both of which pass through outer shaft **654**, and typically exit the outer shaft through respective lateral openings **662A** and **662B**. Thereafter, multiple-anchor delivery tool **600C** is used to push distal tubular tip element **652** into coronary sinus **115**, with stent anchor **646** removably disposed surrounding the longitudinal portion of inner stent-deployment shaft **650** and within distal tubular tip element **652**. Distal tubular tip element **652** is advanced in the coronary sinus until sufficient tension has been applied to the tethers and thus to the valve. For example, multiple-anchor delivery tool **600C** may be used to achieve the deployment configurations described hereinabove with reference to FIGS. **3J**, **3K**, and **3N** (FIGS. **6H**, **6I**, **8E**, **8F**, and **8G** also show similar configurations). In order to accommodate additional deployment configurations, the pulley may be connected to the appropriate tissue anchor of the system.

[**0317**] Reference is made to FIG. **11D**. Multiple-anchor delivery tool **600D** is configured to deploy a helical tissue anchor **640** and stent anchor **646**. Multiple-anchor delivery tool **600D** is capable of deploying either the helical tissue anchor or the stent anchor first. Stent anchor **646** is connected to first venous tissue anchor **30** in SVC **110** or IVC **80**, via a tether, such as using mating techniques described in US Patent Application Publication 2013/0018459, as described hereinabove. For some applications, multiple-anchor deliv-

ery tool **600D** is used to achieve the deployment configurations described hereinabove with reference to FIGS. **3L**, **3M**, and **6F**.

[0318] Reference is now made to FIGS. **12A-C**, which are schematic illustrations of the deployment of a valve-tensioning implant system using multiple-anchor delivery tool **600A**, in accordance with an application of the present invention. Similar techniques can be used for deployment of a valve-tensioning implant using multiple-anchor delivery tools **600B**, **600C**, and **600D**, mutatis mutandis.

[0319] As shown in FIG. **12A**, multiple-anchor delivery tool **600A** is used to first deploy stent anchor **646** in coronary sinus **115**, as described hereinabove with reference to FIGS. **11A-D**.

[0320] As shown in FIG. **12B**, multiple-anchor delivery tool **600A** is then used to deploy helical tissue anchor **640** on

the annulus. Alternatively, helical tissue anchor **640** is deployed before stent anchor **646**.

[0321] As shown in FIG. **12C**, a venous tissue anchor **30** is deployed in SVC **110** and tension is applied on a first tether **740** connecting venous tissue anchor **30** and stent anchor **646** to a pulley **750**, which is connected by a second tether **742** to helical tissue anchor **640**.

[0322] The following table sets forth exemplary uses of multiple-anchor delivery tool **300**, described hereinabove with reference to FIGS. **9A-B**, and/or multiple-anchor delivery tools **600A**, **600B**, **600C**, or **600D**, to achieve some of the deployment configurations described hereinabove. One or more of these delivery tools may optionally be used to achieve others of the deployment configurations described hereinabove, mutatis mutandis.

TABLE 4

First implantation site 89	Second implantation site 190 (pulley) anatomical marker	Third implantation site 192 anatomical marker	FIG.	Delivery method	Sequence of Delivery
Inferior vena cava 80	Circumferential middle 93 of septal leaflet 82	Anteroposterior commissure 112	FIG. 6A	Using sequence of FIGS. 10A-C and multiple-anchor delivery tool 300	Helical tissue anchors in any order and then stent anchor
Inferior vena cava 80	Anteroposterior commissure 112	Circumferential middle 93 of septal leaflet 82	FIG. 6B	Using sequence of FIGS. 10A-C and multiple-anchor delivery tool 300	Helical tissue anchors in any order and then stent anchor
Inferior vena cava 80	Circumferential middle 119 of posterior leaflet 84	Septoanterior commissure 114	FIG. 6C	Using sequence of FIGS. 10A-C and multiple-anchor delivery tool 300	Helical tissue anchors in any order and then stent anchor
Inferior vena cava 80	Septoanterior commissure 114	Circumferential middle 119 of posterior leaflet 84	FIG. 6D	Using sequence of FIGS. 10A-C and multiple-anchor delivery tool 300	Helical tissue anchors in any order and then stent anchor
Superior vena cava 110	Circumferential middle 121 of anterior leaflet 86	Circumferential middle 119 of posterior leaflet 84	FIG. 6E	Using sequence of FIGS. 10A-C and multiple-anchor delivery tool 300	Helical tissue anchors in any order and then stent anchor
Superior vena cava 110	Anteroposterior commissure 112	Coronary Sinus 115	FIG. 6F	Using sequence of FIGS. 12A-B and multiple-anchor delivery tool 600A	Helical tissue anchor or stent anchor first in CS and then the stent anchor in SVC 110
Superior vena cava 110	Circumferential middle 119 of posterior leaflet 84	Circumferential middle 121 of anterior leaflet 86	FIG. 6G	Using sequence of FIGS. 10A-C and multiple-anchor	Helical tissue anchors in any order and then

TABLE 4-continued

First implantation site 89	Second implantation site 190 (pulley) anatomical marker	Third implantation site 192 anatomical marker	FIG.	Delivery method	Sequence of Delivery
				delivery tool 300	stent anchor
Coronary Sinus 115	Anteroposterior commissure 112	Septoanterior commissure 114	FIG. 6H	Multiple-anchor delivery tool 600C	Helical tissue anchors in any order and then stent anchor
Coronary Sinus 115	Circumferential middle 121 of anterior leaflet 86	Circumferential middle 119 of posterior leaflet 84	FIG. 6I	Multiple-anchor delivery tool 600C	Helical tissue anchors in any order and then stent anchor

[0323] The scope of the present invention includes embodiments described in the following applications, which are assigned to the assignee of the present application and are incorporated herein by reference. In an embodiment, techniques and apparatus described in one or more of the following applications are combined with techniques and apparatus described herein:

- [0324]** U.S. Pat. No. 8,475,525 to Maisano et al.;
- [0325]** International Application PCT/IL2011/000064, filed Jan. 20, 2011, which published as PCT Publication WO 2011/089601, and U.S. application Ser. No. 13/574,088 in the national stage thereof, which published as US Patent Application Publication 2013/0046380;
- [0326]** U.S. application Ser. No. 13/188,175, filed Jul. 21, 2011, which published as US Patent Application Publication 2012/0035712;
- [0327]** U.S. application Ser. No. 13/485,145, filed May 31, 2012, which published as US Patent Application Publication 2013/0325115;
- [0328]** U.S. application Ser. No. 13/553,081, filed Jul. 19, 2012, which published as US Patent Application Publication 2013/0018459;
- [0329]** International Application PCT/IL2012/000282, filed Jul. 19, 2012, which published as PCT Publication WO 2013/011502;
- [0330]** U.S. Provisional Application 61/750,427, filed Jan. 9, 2013;
- [0331]** U.S. Provisional Application 61/783,224, filed Mar. 14, 2013;
- [0332]** International Application PCT/IL2013/050470, filed May 30, 2013, which published as PCT Publication WO 2013/179295;
- [0333]** U.S. Provisional Application 61/897,491, filed Oct. 30, 2013;
- [0334]** U.S. application Ser. No. 14/143,355, filed Dec. 30, 2013, which published as US Patent Application Publication 2014/0114390;
- [0335]** International Application PCT/IL2014/050027, filed Jan. 9, 2014, which published as PCT Publication WO 2014/108903;
- [0336]** International Application PCT/IL2014/050233, filed Mar. 9, 2014, which published as PCT Publication WO 2014/141239; and

[0337] U.S. Provisional Application 62/014,397, filed Jun. 19, 2014.

[0338] In particular, the stents described herein may be used as one or more of the stents described in the above-listed applications, in combination with the other techniques described therein.

[0339] It will be appreciated by persons skilled in the art that the present invention is not limited to what has been particularly shown and described hereinabove. Rather, the scope of the present invention includes both combinations and subcombinations of the various features described hereinabove, as well as variations and modifications thereof that are not in the prior art, which would occur to persons skilled in the art upon reading the foregoing description.

1-104. (canceled)

105. A method comprising:

implanting:

a first venous tissue anchor in a vein selected from the group of veins consisting of: a superior vena cava, an inferior vena cava, and a coronary sinus,

exactly two atrial tissue anchors, which consist of second and third atrial tissue anchors, at respective different atrial sites, each of which sites is selected from the group of sites consisting of: an annulus of a tricuspid valve, and a wall of a right atrium of a heart above the annulus of the tricuspid valve, and

a pulley system, which includes (a) a pulley, which is connected to the second atrial tissue anchor, and (b) a tether, which (i) is connected to the first venous tissue anchor and the third atrial tissue anchor, (ii) is moveable through the pulley, and (iii) has a length, measured between the first venous and the third atrial tissue anchors, of at least 30 mm; and

reducing a size of a tricuspid orifice by tensioning the tether.

106. The method according to claim **105**, wherein the pulley includes a loop, and wherein tensioning the tether comprises sliding the tether through the loop.

107. (canceled)

108. The method according to claim **106**, wherein the loop is a closed loop.

109. The method according to claim **105**, wherein the pulley includes a ring, and wherein tensioning the tether comprises sliding the tether through the ring.

110. (canceled)

111. The method according to claim **105**, wherein the pulley includes a wheel, and wherein tensioning the tether comprises rotating the wheel by moving the tether through the pulley.

112. The method according to claim **105**, wherein the first venous tissue anchor includes an intraluminal stent, and wherein implanting the first venous tissue anchor comprises expanding the intraluminal stent in the selected vein.

113. The method according to claim **112**, wherein the second and the third atrial tissue anchors include respective helical tissue-coupling elements, and wherein implanting the second and the third atrial tissue anchors comprises rotating the helical tissue-coupling elements into tissue at the sites, respectively.

114. The method according to claim **105**, wherein implanting the first venous tissue anchor, the second atrial tissue anchor, the third atrial tissue anchor, and the pulley system comprises positioning the first venous tissue anchor, the second atrial tissue anchor, the third atrial tissue anchor, and the pulley system such that two longitudinal portions of the tether adjacent to and on opposite sides of the pulley define an angle therebetween of between 40 and 85 degrees.

115. (canceled)

116. The method according to claim **105**,

wherein implanting the first venous tissue anchor comprises implanting the first venous tissue anchor in the inferior vena cava,

wherein implanting the second atrial tissue anchor comprises implanting the second atrial tissue anchor within 1 cm of a site on the annulus that circumferentially corresponds to a circumferential middle of a septal leaflet of the tricuspid valve, and

wherein implanting the third atrial tissue anchor comprises implanting the third atrial tissue anchor within 1 cm of a site on the annulus that circumferentially corresponds to an anteroposterior commissure of the tricuspid valve.

117. The method according to claim **105**,

wherein implanting the first venous tissue anchor comprises implanting the first venous tissue anchor in the inferior vena cava,

wherein implanting the second atrial tissue anchor comprises implanting the second atrial tissue anchor within 1 cm of a site on the annulus that circumferentially corresponds to a septoanterior commissure of the tricuspid valve, and

wherein implanting the third atrial tissue anchor comprises implanting the third atrial tissue anchor within 1 cm of a site on the annulus that circumferentially corresponds to an anteroposterior commissure of the tricuspid valve.

118. The method according to claim **105**,

wherein implanting the first venous tissue anchor comprises implanting the first venous tissue anchor in the inferior vena cava, and

wherein implanting the second atrial tissue anchor comprises implanting the second atrial tissue anchor within 1 cm of a site on the annulus that circumferentially corresponds to an anteroposterior commissure of the tricuspid valve.

119. The method according to claim **118**, wherein implanting the third atrial tissue anchor comprises implanting the

third atrial tissue anchor within 1 cm of a site on the annulus that circumferentially corresponds to a septoanterior commissure of the tricuspid valve.

120-124. (canceled)

125. The method according to claim **105**,

wherein implanting the first venous tissue anchor comprises implanting the first venous tissue anchor in the superior vena cava, and

wherein implanting the second atrial tissue anchor comprises implanting the second atrial tissue anchor within 1 cm of a site on the annulus that circumferentially corresponds to an anteroposterior commissure of the tricuspid valve.

126. (canceled)

127. The method according to claim **125**, wherein implanting the third atrial tissue anchor comprises implanting the third atrial tissue anchor within 1 cm of a site on the annulus that circumferentially corresponds to a circumferential middle of a septal leaflet of the tricuspid valve.

128-131. (canceled)

132. The method according to claim **105**,

wherein implanting the first venous tissue anchor comprises implanting the first venous tissue anchor in the coronary sinus,

wherein implanting the second atrial tissue anchor comprises implanting the second atrial tissue anchor within 1 cm of a site on the annulus that circumferentially corresponds to an anteroposterior commissure of the tricuspid valve, and

wherein implanting the third atrial tissue anchor comprises implanting the third atrial tissue anchor within 1 cm of a site on the annulus that circumferentially corresponds to a septoanterior commissure of the tricuspid valve.

133. The method according to claim **105**,

wherein the tether is a first tether, and the length is a first length,

wherein the pulley system further comprises a second tether, which (a) is connected to the pulley and the second atrial tissue anchor, so as to connect the pulley to the second atrial tissue anchor, and (b) has a second length, measured between the second atrial tissue anchor and the pulley, of at least 3 mm, and

wherein implanting the pulley system further comprises implanting the second tether.

134. The method according to claim **105**,

wherein the second atrial tissue anchor comprises (a) a tissue-coupling element, and (b) a head,

wherein the pulley is connected to the head, and

wherein tensioning the tether comprises fully extending the pulley away from the head, such that a distance between (a) a site on the pulley farthest from the head and (b) a site on the head closest to the pulley, is at least 3 mm.

135. (canceled)

136. The method according to claim **134**, wherein the head includes a tether interface that is rotatable with respect to the tissue-coupling element.

137. The method according to claim **105**, wherein implanting the first venous tissue anchor, the second atrial tissue anchor, the third atrial tissue anchor, and the pulley system comprises positioning the first venous tissue anchor, the second atrial tissue anchor, the third atrial tissue anchor, and the pulley system such that two longitudinal portions of the tether

adjacent to and on opposite sides of the pulley define an angle therebetween of at least 120 degrees.

138. (canceled)

139. The method according to claim **105**, wherein implanting the first venous tissue anchor, the second atrial tissue anchor, the third atrial tissue anchor, and the pulley system comprises positioning the first venous tissue anchor, the second atrial tissue anchor, the third atrial tissue anchor, and the pulley system such that two longitudinal portions of the tether adjacent to and on opposite sides of the pulley define an angle there between of less than 90 degrees.

140. The method according to claim **139**, wherein the angle is less than 60 degrees.

141. The method according to claim **105**, wherein the second atrial tissue anchor includes (a) a tissue-coupling element, and (b) a head, which includes the pulley, and wherein implanting the second atrial tissue anchor comprises implanting the head.

142. The method according to claim **141**, wherein the head includes an interface, which (a) includes the pulley and (b) is rotatable with respect to the tissue-coupling element.

143. The method according to claim **141**, wherein the pulley includes an eyelet.

144. The method according to claim **141**, wherein the pulley includes a roller.

145. The method according to claim **141**, wherein the pulley includes a flexible longitudinal member that is connected to the head at two points along the flexible longitudinal member, so as to define a loop longitudinally between the two points.

146-147. (canceled)

148. A method comprising:
implanting:

a first venous tissue anchor in a vein selected from the group of veins consisting of: a superior vena cava, an inferior vena cava, and a coronary sinus,

exactly two atrial tissue anchors, which consist of second and third atrial tissue anchors, at respective different atrial sites, each of which sites is selected from the group of sites consisting of: an annulus of a tricuspid valve, and a wall of a right atrium of a heart above the annulus of the tricuspid valve, and

a pulley system, which includes (a) a pulley, which is connected to the first venous tissue anchor, (b) a first tether, which (i) is connected to the second and the third atrial tissue anchors, (ii) is moveable through the pulley, and (iii) has a first length, measured between the second and the third atrial tissue anchors, of at least 10 mm, and (c) a second tether, which (i) is connected to the first venous tissue anchor and to the pulley, and (ii) has a second length, measured between the first venous tissue anchor and the pulley, of at least 30 mm; and

reducing a size of a tricuspid orifice by tensioning the second tether.

149-158. (canceled)

159. The method according to claim **148**,

wherein implanting the first venous tissue anchor comprises implanting the first venous tissue anchor in the inferior vena cava,

wherein implanting the second atrial tissue anchor comprises implanting the second atrial tissue anchor within 1 cm of a site on the annulus that circumferentially corresponds to an anteroposterior commissure of the tricuspid valve, and

wherein implanting the third atrial tissue anchor comprises implanting the third atrial tissue anchor within 1 cm of a site on the annulus that circumferentially corresponds to a circumferential middle of a septal leaflet of the tricuspid valve.

160-228. (canceled)

229. The method according to claim **105**,

wherein implanting the first venous tissue anchor comprises implanting the first venous tissue anchor in the superior vena cava,

wherein implanting the second atrial tissue anchor comprises implanting the second atrial tissue anchor within 1 cm of a site on the annulus that circumferentially corresponds to a circumferential middle of a septal leaflet of the tricuspid valve, and

wherein implanting the third atrial tissue anchor comprises implanting the third atrial tissue anchor within 1 cm of a site on the annulus that circumferentially corresponds to a circumferential middle of a posterior leaflet of the tricuspid valve.

230. The method according to claim **141**,

wherein implanting the first venous tissue anchor comprises implanting the first venous tissue anchor in the inferior vena cava,

wherein implanting the second atrial tissue anchor comprises implanting the second atrial tissue anchor within 1 cm of a site on the annulus that circumferentially corresponds to a septoanterior commissure of the tricuspid valve, and

wherein implanting the third atrial tissue anchor comprises implanting the third atrial tissue anchor within 1 cm of a site on the annulus that circumferentially corresponds to a circumferential middle of a posterior leaflet of the tricuspid valve.

231. The method according to claim **141**,

wherein implanting the first venous tissue anchor comprises implanting the first venous tissue anchor in the superior vena cava,

wherein implanting the second atrial tissue anchor comprises implanting the second atrial tissue anchor within 1 cm of a site on the annulus that circumferentially corresponds to a circumferential middle of an anterior leaflet of the tricuspid valve, and

wherein implanting the third atrial tissue anchor comprises implanting the third atrial tissue anchor within 1 cm of a site on the annulus that circumferentially corresponds to a circumferential middle of a posterior leaflet of the tricuspid valve.

232. The method according to claim **141**,

wherein implanting the first venous tissue anchor comprises implanting the first venous tissue anchor in the inferior vena cava,

wherein implanting the second atrial tissue anchor comprises implanting the second atrial tissue anchor within 1 cm of a site on the annulus that circumferentially corresponds to a circumferential middle of a posterior leaflet of the tricuspid valve, and

wherein implanting the third atrial tissue anchor comprises implanting the third atrial tissue anchor within 1 cm of a site on the annulus that circumferentially corresponds to a circumferential middle of an anterior leaflet of the tricuspid valve.

233. The method according to claim **105**, wherein implanting the first venous tissue anchor comprises implanting the first venous tissue anchor in the superior vena cava, wherein implanting the second atrial tissue anchor comprises implanting the second atrial tissue anchor within 1 cm of a site on the annulus that circumferentially corresponds to a septoanterior commissure of the tricuspid valve, and wherein implanting the third atrial tissue anchor comprises implanting the third atrial tissue anchor within 1 cm of a site on the annulus that circumferentially corresponds to an anteroposterior commissure of the tricuspid valve.

234. The method according to claim **105**, wherein implanting the first venous tissue anchor comprises implanting the first venous tissue anchor in the superior vena cava, wherein implanting the second atrial tissue anchor comprises implanting the second atrial tissue anchor within 1 cm of a site on the annulus that circumferentially corresponds to a circumferential middle of a septal leaflet of the tricuspid valve, and wherein implanting the third atrial tissue anchor comprises implanting the third atrial tissue anchor within 1 cm of a

site on the annulus that circumferentially corresponds to an anteroposterior commissure of the tricuspid valve.

235. The method according to claim **148**, wherein the pulley includes a loop, and wherein tensioning the first tether comprises sliding the first tether through the loop.

236. The method according to claim **148**, wherein the pulley includes a ring, and wherein tensioning the first tether comprises sliding the first tether through the ring.

237. The method according to claim **148**, wherein implanting the first venous tissue anchor comprises implanting the first venous tissue anchor in the superior vena cava.

238. The method according to claim **237**, wherein implanting the third atrial tissue anchor comprises implanting the third atrial tissue anchor within 1 cm of a site on the annulus that circumferentially corresponds to an anteroposterior commissure of the tricuspid valve.

239. The method according to claim **238**, wherein implanting the second atrial tissue anchor comprises implanting the second atrial tissue anchor within 1 cm of a site on the annulus that circumferentially corresponds to a septoanterior commissure of the tricuspid valve.

* * * * *