



(19) **United States**

(12) **Patent Application Publication**

Beck et al.

(10) **Pub. No.: US 2016/0238644 A1**

(43) **Pub. Date: Aug. 18, 2016**

(54) **SINGLE WOUND CURRENT TRANSFORMER IMPEDANCE MEASUREMENT CIRCUIT**

Publication Classification

(71) Applicant: **SEMICONDUCTOR COMPONENTS INDUSTRIES, LLC, Phoenix, AZ (US)**

(51) **Int. Cl.**
G01R 27/18 (2006.01)
G01R 15/18 (2006.01)
G01R 27/16 (2006.01)

(72) Inventors: **Riley D. Beck**, Eagle Mountain, UT (US); **Kent D. Layton**, Lehi, UT (US); **Matthew A. Tyler**, Kaysville (AZ); **Scott R. Grange**, Pleasant Grove, UT (US)

(52) **U.S. Cl.**
CPC **G01R 27/18** (2013.01); **G01R 27/16** (2013.01); **G01R 15/18** (2013.01)

(73) Assignee: **SEMICONDUCTOR COMPONENTS INDUSTRIES, LLC, Phoenix, AZ (US)**

(57) **ABSTRACT**

A single wound single current transformer impedance measurement circuit for determining a circuit element parameter in a ground fault circuit interrupter circuit. The circuit includes a transconductance amplifier having first and second input terminals and first and second output terminals. In an embodiment, a first detector has input terminal coupled to the first output terminal of the transconductance amplifier and another input terminal coupled for receiving a first electrical signal. A second detector has a terminal coupled to the second output terminal of the transconductance amplifier and an input terminal coupled for receiving the first electrical signal. Alternatively, the second detector has an input terminal coupled to the first output terminal of the transconductance amplifier and another input terminal coupled for receiving the first electrical signal.

(21) Appl. No.: **15/138,534**

(22) Filed: **Apr. 26, 2016**

Related U.S. Application Data

(62) Division of application No. 13/752,565, filed on Jan. 29, 2013, now Pat. No. 9,329,216, which is a division of application No. 12/572,870, filed on Oct. 2, 2009, now Pat. No. 8,390,297.

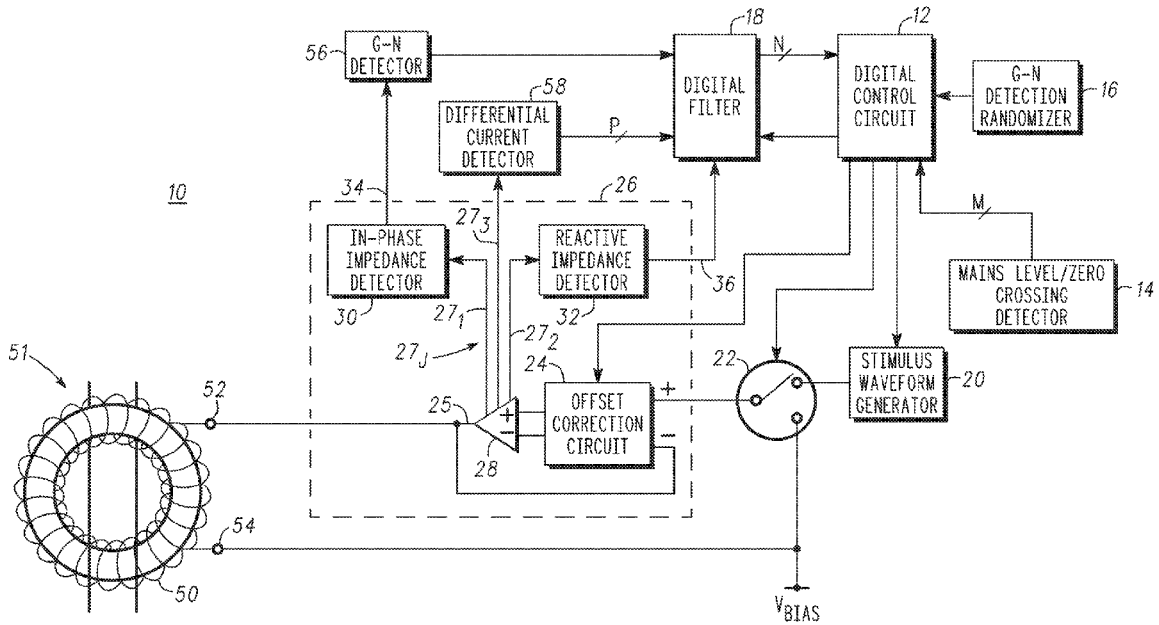

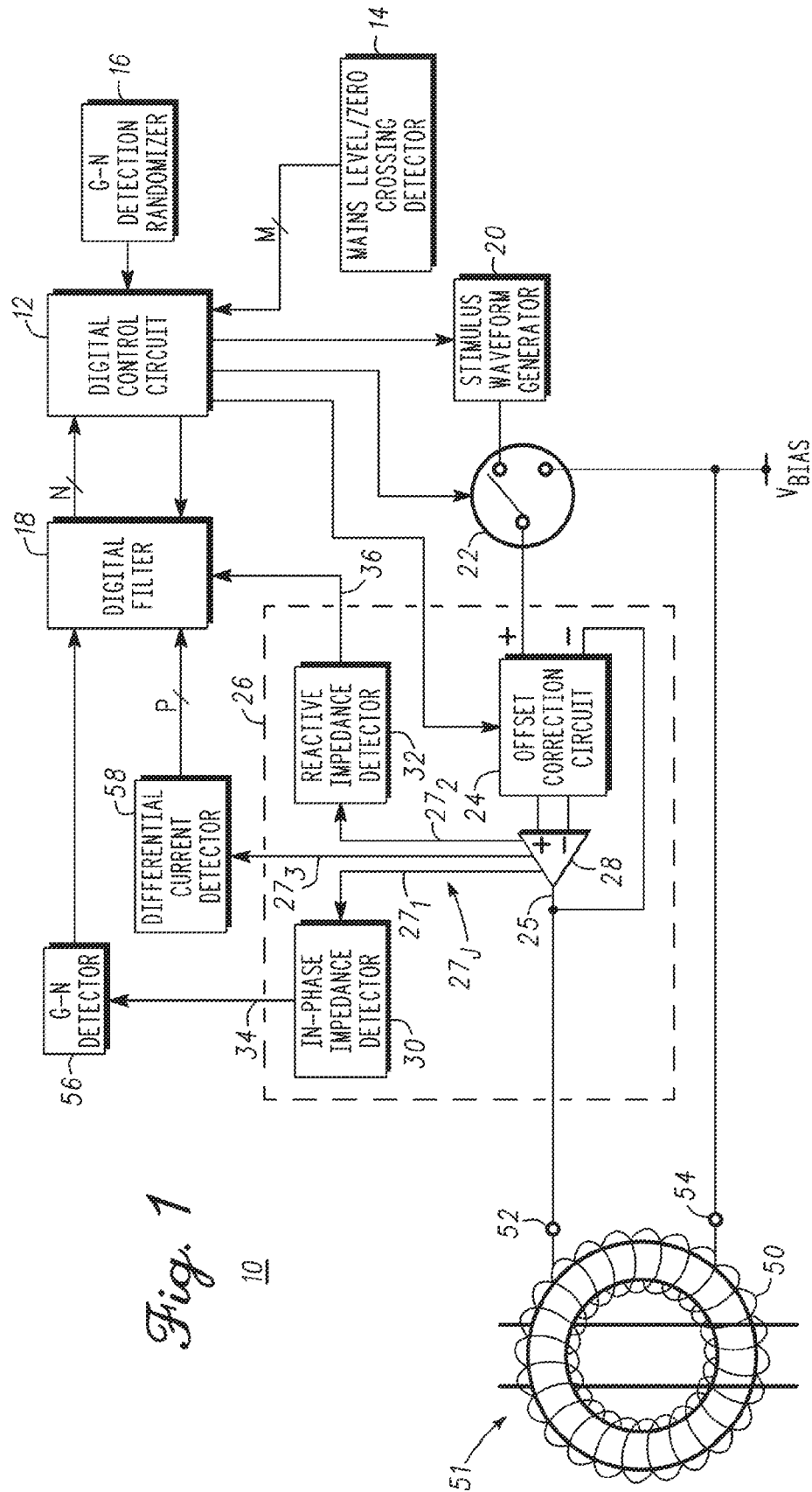

Fig. 1

10

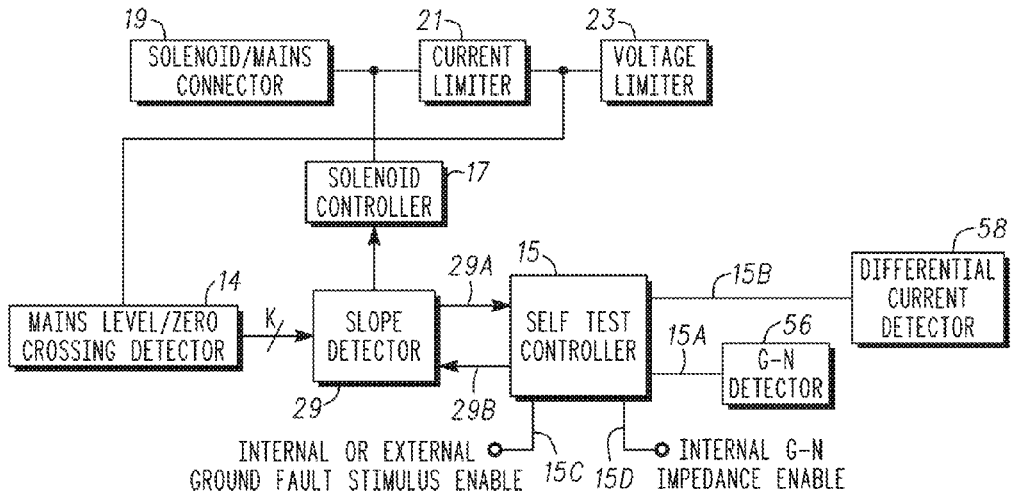
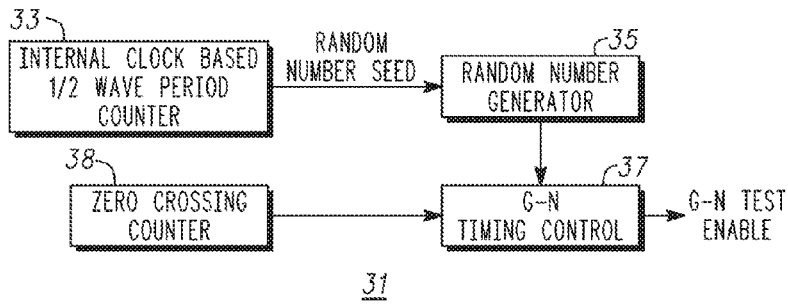
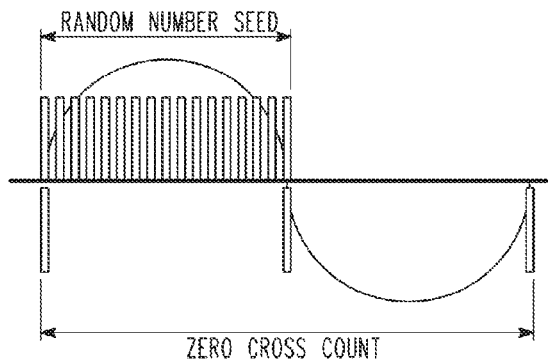

Fig. 2



31

Fig. 3



41

Fig. 4

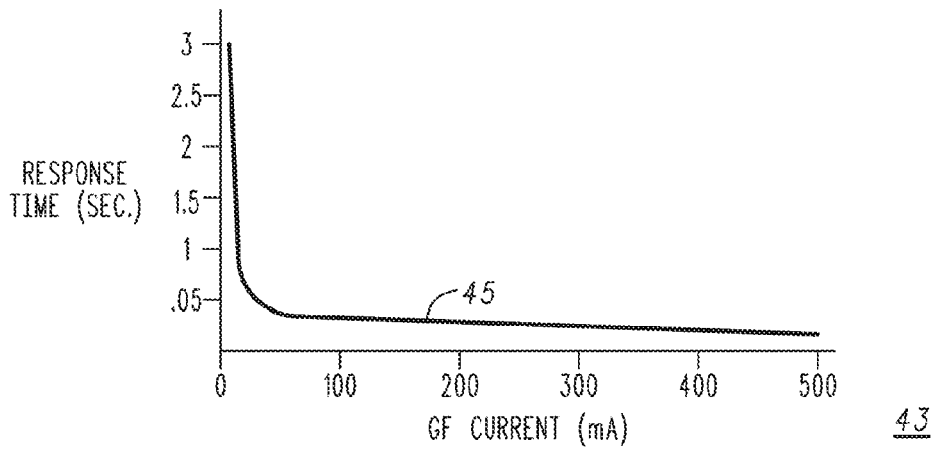

Fig. 5

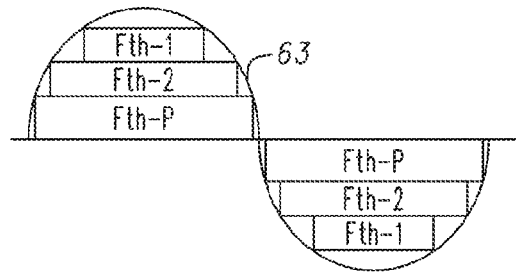
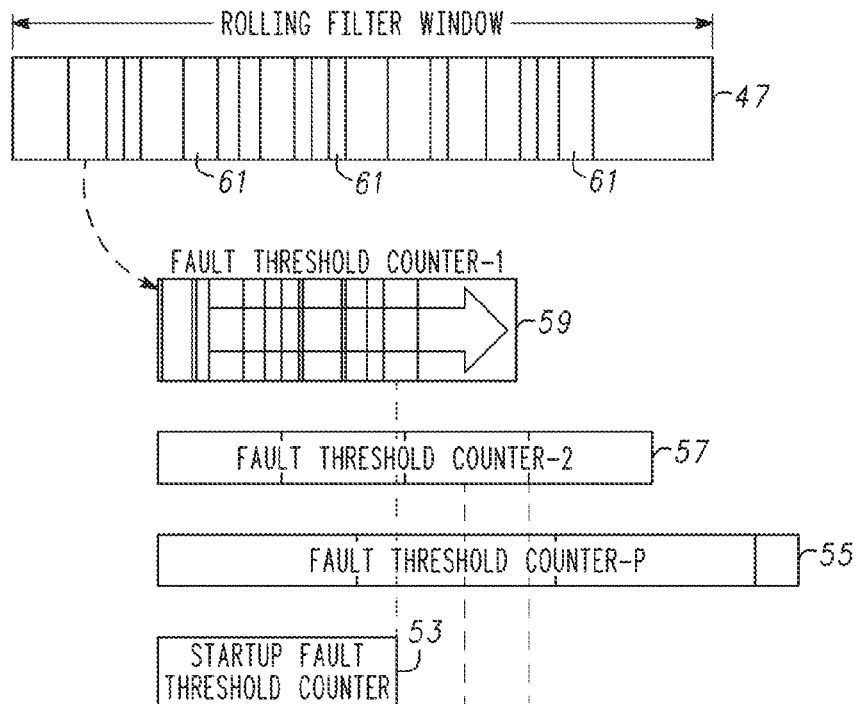
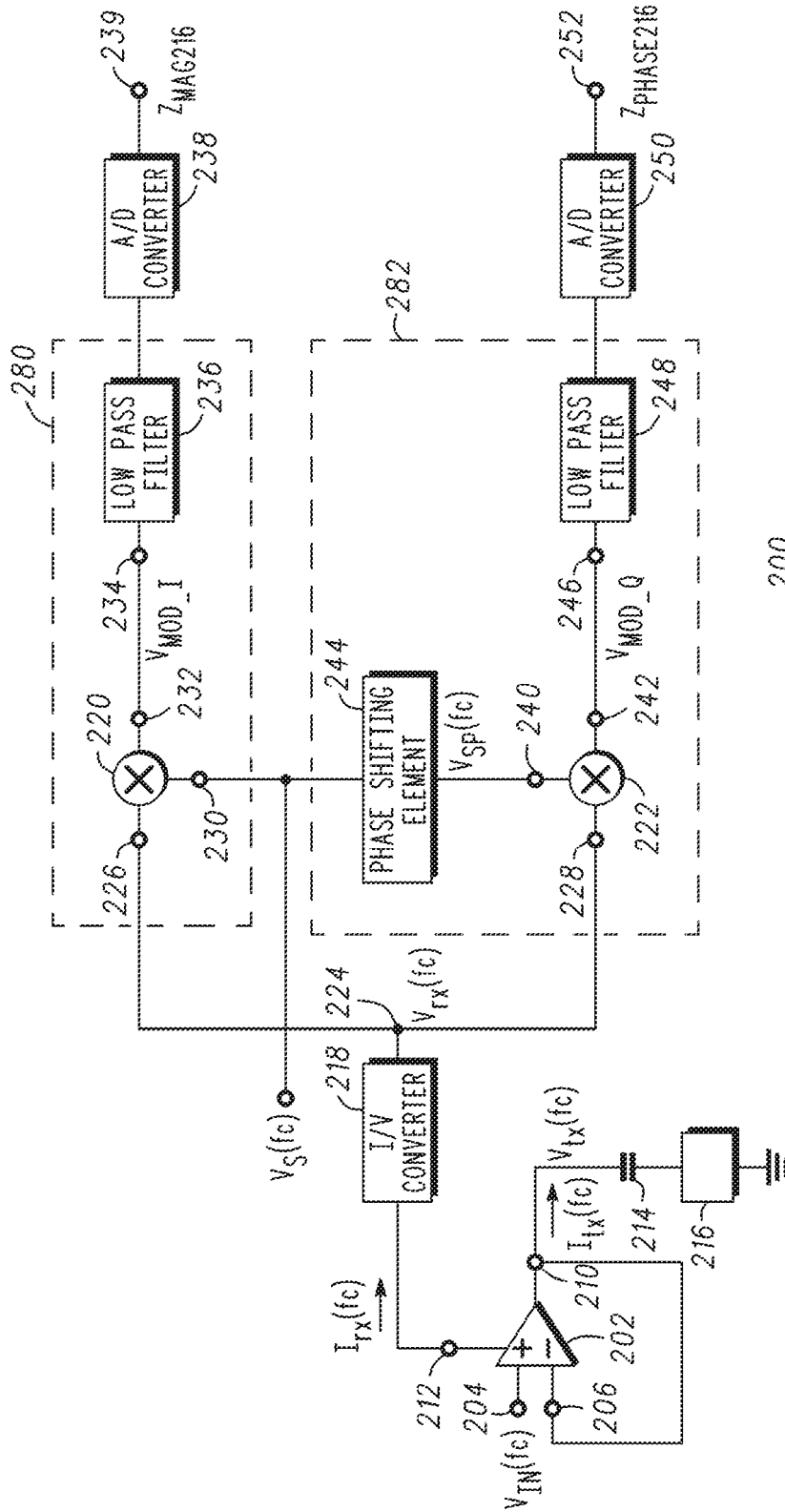

Fig. 6





200

Fig. 7

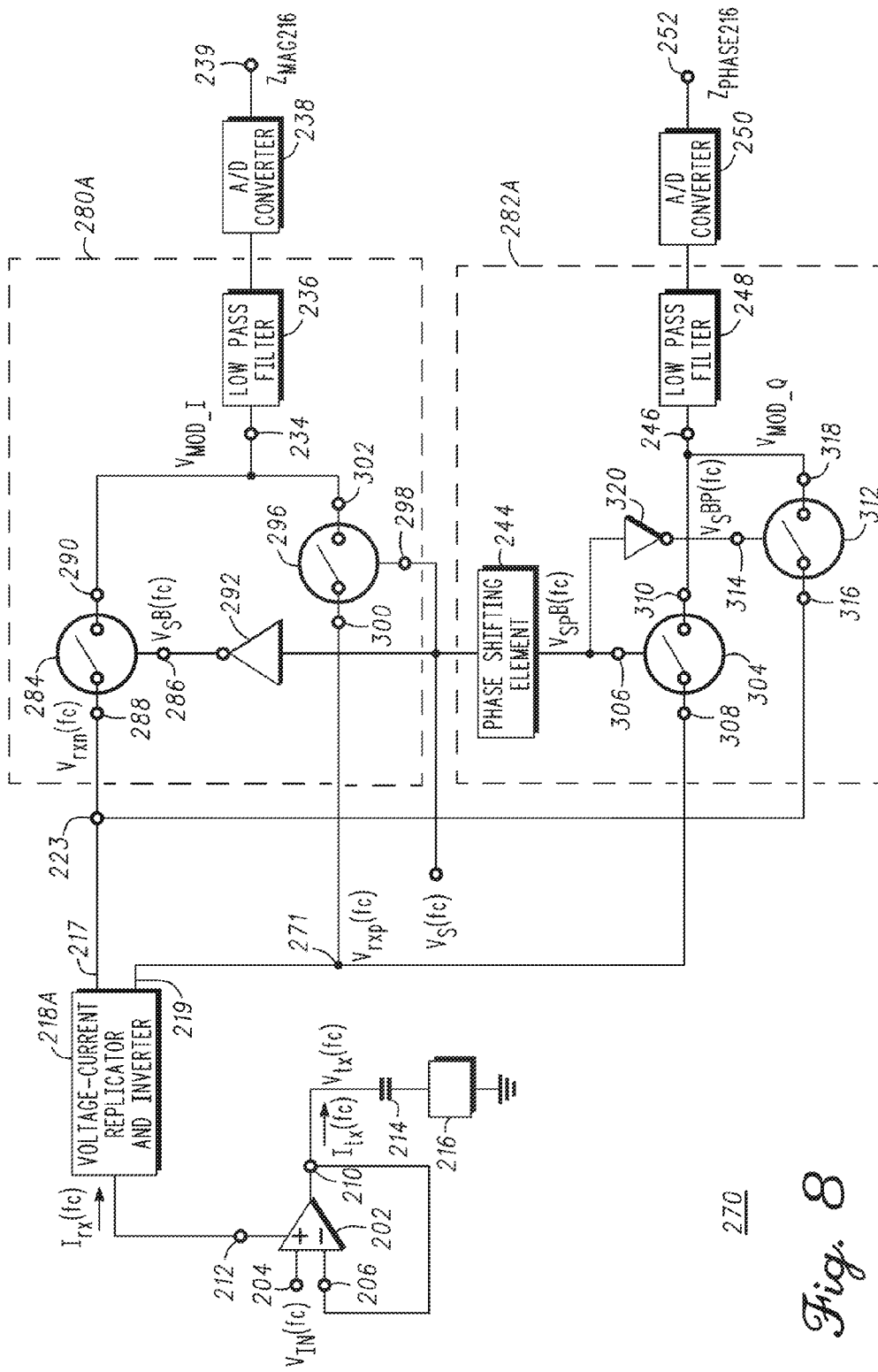

270

Fig. 8

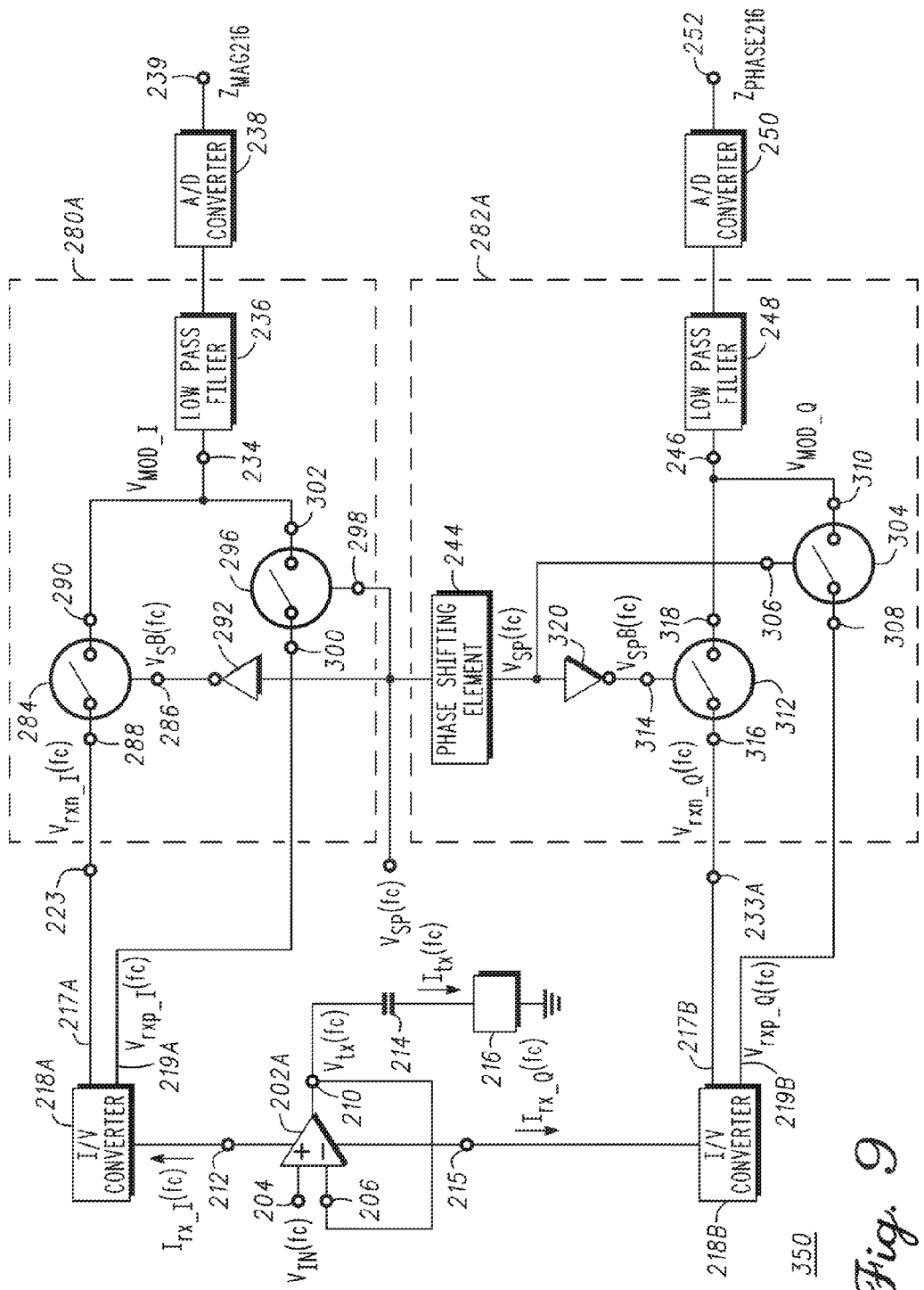
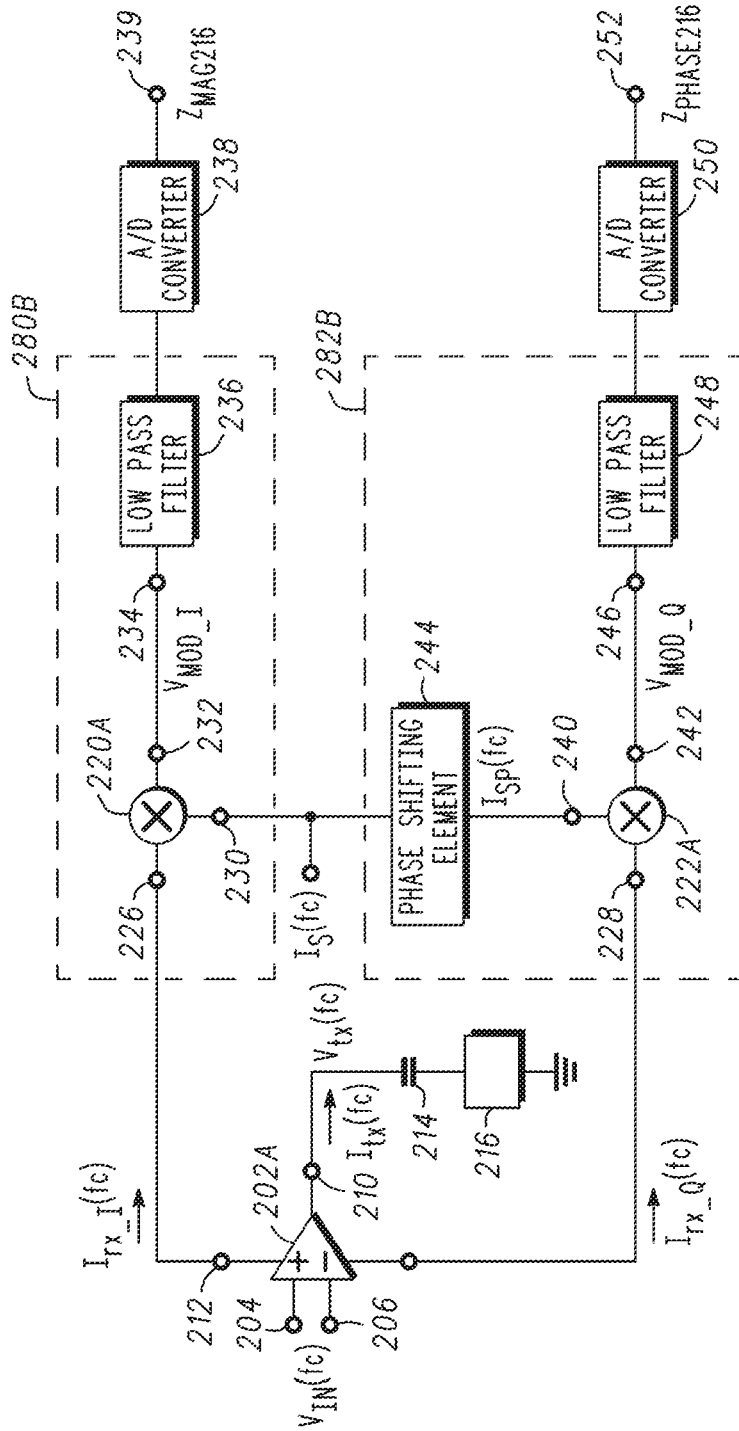

Fig. 9

350



370

Fig. 10

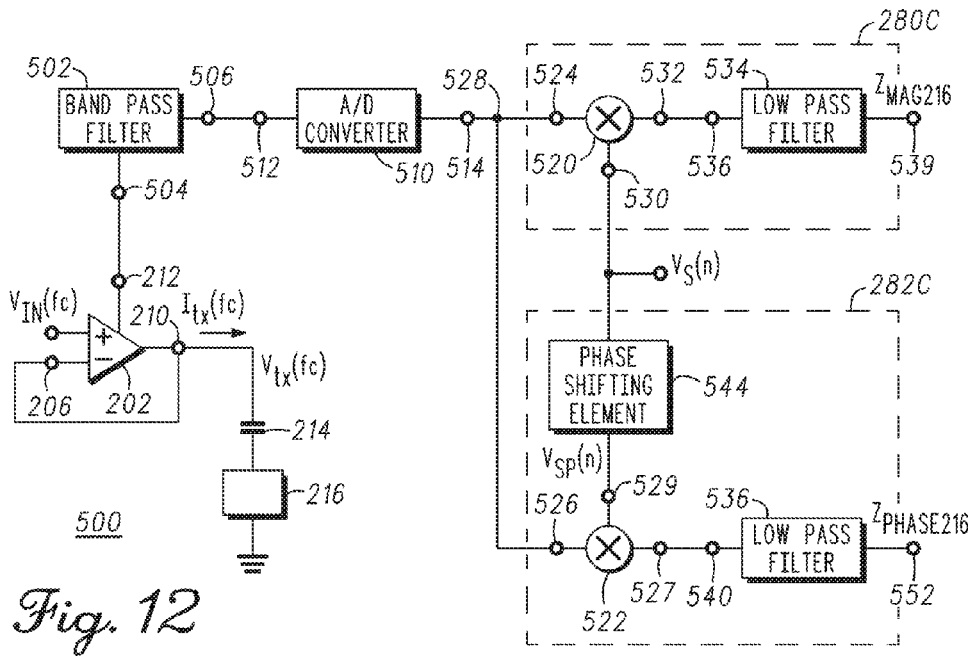
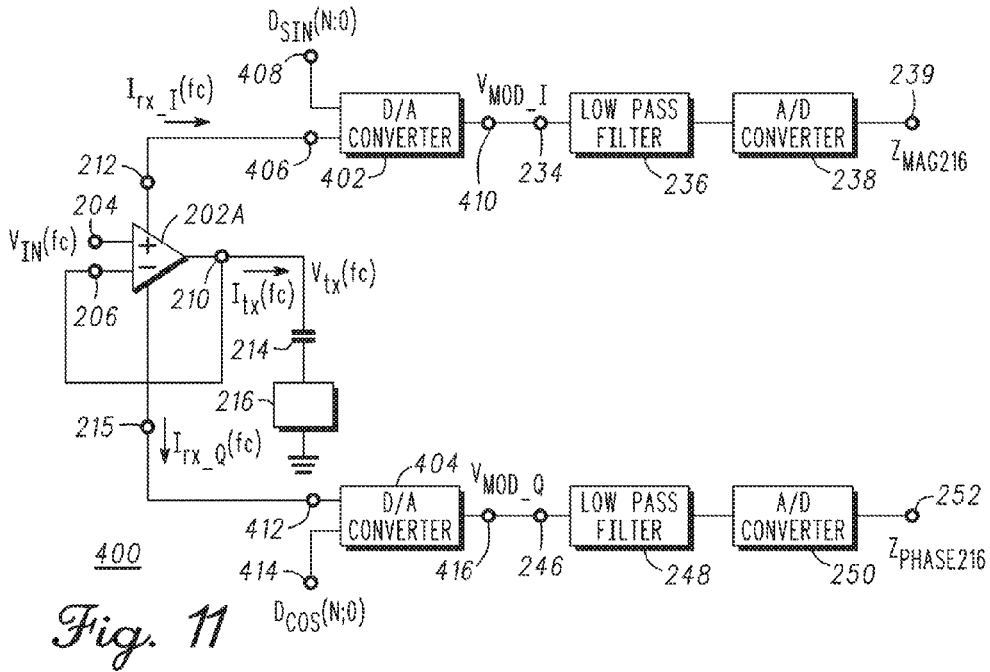

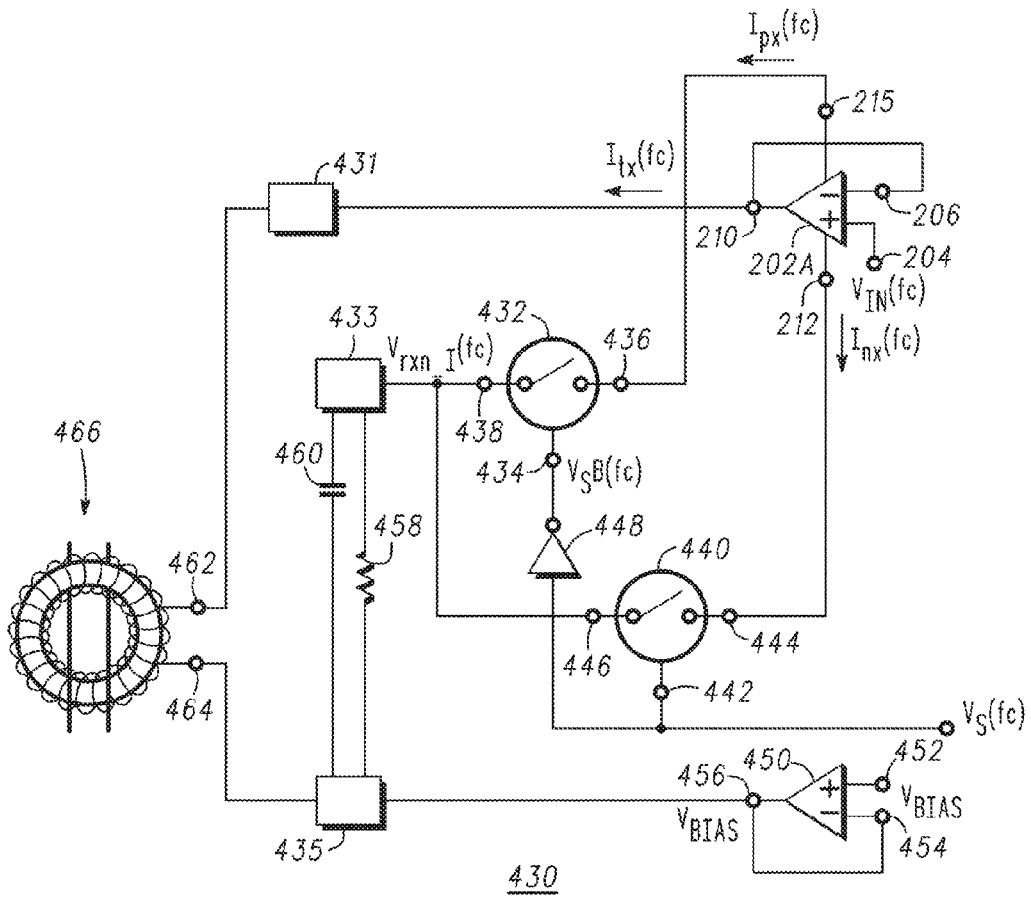

Fig. 13

SINGLE WOUND CURRENT TRANSFORMER IMPEDANCE MEASUREMENT CIRCUIT

[0001] The present patent application is a divisional application of prior U.S. patent application Ser. No. 13/752,565, filed on Jan. 29, 2013, by Riley D. Beck et al., titled "Impedance Measuring Circuit," which is a divisional application of prior U.S. patent application Ser. No. 12/572,870, filed on Oct. 2, 2009, now U.S. Pat. No. 8,390,297 issued Mar. 5, 2013, by Riley D. Beck et al., titled "Ground Fault Circuit Interrupter and Method," which applications are hereby incorporated by reference in their entirety, and priority thereto for common subject matter is hereby claimed.

TECHNICAL FIELD

[0002] The present invention relates, in general, to measurement systems and, more particularly, to the measurement systems for electrical signals.

BACKGROUND

[0003] Circuits for measuring or calculating electrical signals such as current, voltage, and power and circuits for measuring or calculating electrical parameters such as impedance, admittance, phase relationships are used in a variety of applications including impedance measurements, load detection and calibration, security systems, smart grids, sensor interfaces, automotive systems, self-test systems, etc. For example, circuits used for determining the impedance of a system may include a resistor placed in series with a load so that the current flowing through the resistor can be used to determine the current flowing through the load. Drawbacks with this technique are the reduction of the input voltage range, the consumption of large areas of semiconductor material to manufacture the circuits, frequency limitations of the circuit elements, and the need for highly accurate circuit elements.

[0004] In some applications it may be desirable to detect a ground fault condition. One technique for detecting this condition is to establish resonance in an inductor-resistor-capacitor network when it is exposed to a ground-to-neutral condition. Resonance may be established by delivering a pulse to a positive feedback system that includes an operational amplifier. Alternatively, a steady state stimulus can be delivered to the circuit, which is then monitored for significant changes in the waveform profile. Drawbacks with these techniques are that they are prone to temperature and manufacturing shifts which reduce the accuracy of detection.

[0005] Accordingly, it would be advantageous to have a circuit and method for determining electrical signals and electrical parameters of a circuit element. It would be of further advantage for the circuit and method to be COST efficient to implement.

BRIEF DESCRIPTION OF THE DRAWINGS

[0006] The present invention will be better understood from a reading of the following detailed description, taken in conjunction with the accompanying drawing figures, in which like reference characters designate like elements and in which:

[0007] FIG. 1 is a block diagram of a measurement circuit in accordance with an embodiment of the present invention;

[0008] FIG. 2 is a block diagram of a portion of a measurement circuit in accordance with an embodiment of the present invention;

[0009] FIG. 3 is a block diagram of a circuit module for randomizing the timing of the ground-to-neutral measurements in accordance with embodiments of the present invention;

[0010] FIG. 4 is a waveform for randomizing the timing of the ground-to-neutral measurements in accordance with embodiments of the present invention;

[0011] FIG. 5 is a timing diagram for a portion of the circuit module of FIG. 1;

[0012] FIG. 6 illustrates a threshold diagram for a portion of the circuit module of FIG. 1;

[0013] FIG. 7 is a schematic diagram of a measurement circuit in accordance with another embodiment of the present invention;

[0014] FIG. 8 is a schematic diagram of a measurement circuit in accordance with another embodiment of the present invention;

[0015] FIG. 9 is a schematic diagram of a measurement circuit in accordance with another embodiment of the present invention;

[0016] FIG. 10 is a schematic diagram of a measurement circuit in accordance with another embodiment of the present invention;

[0017] FIG. 11 is a schematic diagram of a measurement circuit in accordance with another embodiment of the present invention;

[0018] FIG. 12 is a schematic diagram of a measurement circuit in accordance with another embodiment of the present invention;

[0019] FIG. 13 is a schematic diagram of a measurement circuit in accordance with another embodiment of the present invention; and

[0020] FIG. 14 is a schematic diagram of a measurement circuit in accordance with another embodiment of the present invention.

DETAILED DESCRIPTION

[0021] Generally, the present invention provides a Ground Fault Circuit Interrupter having various elements including an impedance measurement circuit. In accordance with embodiments of the present invention, an Operational Transconductance Amplifier (OTA) generates a plurality of output signals. For example, the OTA may generate a plurality of output currents where second, third, fourth, etc. currents are copies of a first current. Alternatively, the OTA may generate a plurality of output voltages where each output voltage of the plurality of output voltages is proportional to an output current of the OTA. When the OTA generates a plurality of output currents, they may be input to corresponding mixers as currents or they may be converted to output voltages which are input to corresponding mixers. A modulator may be used to modulate at least one of the current or voltage signals from the OTA by an in-phase signal resulting in a modulated signal that is filtered by a low pass filter to pass the baseband voltage of the mixed signal. Preferably, the in-phase signal is in phase with the input signal to the OTA. The output signal of the low pass filter is digitized by an analog-to-digital converter to determine multiple real impedance levels or by a comparator to determine a specific real impedance. In addition, a modulator may be used to modulate at least one of the current or voltage signals from the OTA by a phase shifted signal result-

ing in a modulated signal that is filtered by a low pass filter, where the modulated signal indicates the reactive impedance of the load. The reactive component is digitized by an analog-to-digital converter or a comparator. Preferably, the phase shifted signal is shifted by ninety degrees from the signal at the input terminal of the OTA.

[0022] In accordance with alternative embodiments, the circuit can be configured to measure just the in-phase impedance or just the quadrature impedance. In addition, a single modulator may be used to measure the in-phase impedance and the quadrature impedance by performing the measurements at different times.

[0023] In addition, embodiments of the present invention are suitable for use with GFCI circuits associated with single wound single current transformer circuits thereby forming a single wound single current transformer based impedance measurement circuit. An advantage of using single wound single current transformer circuits is that they are less expensive to implement.

[0024] FIGS. 1, 2, and 3 are block diagrams of a Ground Fault Circuit Interrupter (GFCI) module 10 in accordance with an embodiment of the present invention. For the sake of clarity, FIGS. 1, 2, and 3 are described together. GFCI module 10 is comprised of a digital control circuit 12 coupled for receiving input signals from a mains level/zero crossing detector circuit 14, a ground-to-neutral (G-N) detection randomizer 16, and a digital filter 18. The signals received from digital filter 18 may be transmitted over a bus connection having N interconnects, where N is an integer and the signals received from mains level detector circuit 14 may be transmitted over a bus connection having M interconnects, where M is an integer. Integers N and M may be the same as each other or they may be different from each other. Digital control circuit 12 is coupled for transmitting signals to digital filter 18, to a stimulus waveform generator 20, to a switch 22, and to an offset correction circuit 24. Although filter 18 is described as a digital filter, this is not a limitation of the present invention. Filter 18 may be an analog filter.

[0025] In accordance with an embodiment, mains level/zero crossing detector circuit 14 is connected to a slope detector 29 through a bus connection having K interconnects, where K is an integer. Slope detector 29 is connected to a self test controller 15 through connections 29A and 29B, where a slope detect fault signal (SD_FAULT) is transmitted to self test controller 15 through connection 29A and a slope detect enable signal (SD_EN) is received from self test controller 15 through connection 29B. Slope detector 29 is connected to a solenoid controller 17, which is connected to a solenoid or the mains through a solenoid/mains connector 19. The connection between slope detector 29 and solenoid controller 17 transmits a solenoid enable signal (SOL_EN) to solenoid controller 17. Self test controller 15 is connected to G-N detector 56 through an output terminal 15A and to differential current detector 58 through an output terminal 15B. In addition, self test controller 15 has an output terminal 15C through which an internal or external ground fault stimulus enable signal is transmitted and an output terminal 15D through which an internal G-N impedance enable signal is transmitted. Alternatively, slope detector 29 may be omitted in which case mains level/zero crossing detector circuit 14 is connected to self test controller 15 through the bus connection having the K interconnects. In this embodiment, self test controller 15 is connected to solenoid controller 17. Mains

level/zero crossing detector 14 is connected to solenoid/mains connector 19 through a current limiter 21 and to a voltage limiter 23.

[0026] The input terminal of mains/line level detector circuit 14 is connected to the power mains or line level of the circuit being monitored by GFCI module 10. It may be connected through a protection structure such as, for example, current limiter 21 shown in FIG. 2. By way of example, current limiter 21 is a resistor. Mains level detector circuit 14 communicates the mains level to digital control circuit 12 and is capable of indicating when the mains level is crossing neutral during a polarity transition or it can indicate when other levels are being used. During a self test, mains level detector circuit 14 can indicate when it is safe for digital control circuit 12 to activate an external device such as, for example, a Silicon Controlled Rectifier (SCR) to test a GFCI solenoid. In addition, mains level detector circuit 14 can be used to determine if the external device is working properly by monitoring the effect of tripping the external device on the mains voltage level. For example, digital control circuit 12 may activate an external transistor or SCR to pull current through an external solenoid. As current is pulled through the transistor or the SCR, the mains voltage decreases or droops at a different rate from that of steady state operation, i.e., there is a change in the slope of mains voltage. The rate at which the mains voltage decreases can be measured by mains level detector circuit 14 to determine if the external device is working properly. Introducing a small change in the slope increases the window after a zero crossing during which the circuit can be tested and indicates when the SCR can be activated. Thus, level detector circuit 14 generates an operating condition signal in accordance with the rate at which the mains voltage level decreases that indicates if the circuit is working properly or if it is safe for digital control circuit 12 to activate an external device.

[0027] Ground-to-neutral detection randomizer 16 is used to determine when GFCI module 10 should check for a ground-to-neutral fault. If multiple GFCI modules 10 are used on the same mains circuit, one GFCI module 10 may corrupt another GFCI module 10 if they operate the ground-to-neutral measurements at the same time. Therefore, it is advantageous to randomize the timing of the ground-to-neutral measurements. G-N detection randomizer 16 randomizes the timing between ground-to-neutral measurements to minimize the likelihood of corrupting them. FIG. 3 is a block diagram of a circuit module 31 for randomizing the timing of the ground-to-neutral measurements. An internal clock based half-wave period counter 33 is connected for transmitting a random number seed to a random number generator 35, which is connected for transmitting the random number generation signal to a G-N timing control circuit 37. In addition, G-N timing control circuit 37 is connected for receiving a zero-crossing count signal from a zero-crossing counter 38 and generates a G-N test enable signal. G-N timing control circuit 37 may be a sub-module within G-N detection randomizer 16. The randomization may be based on the number of oscillations of a clock in a given period of the mains cycle as illustrated in FIG. 4. What is shown in FIG. 4 is a plot 41 illustrating the mains cycle having three zero crossings and a random number seed based on a counter that counts during a half period of the mains cycle.

[0028] Offset correction circuit 24 is used to minimize the effective offset of an Operational Transconductance Amplifier (OTA) 28. If a DC blocking capacitor is not used in series

with current transformer 51, an offset voltage in OTA 28 will produce a DC current through current transformer 51. The DC current will affect the accuracy of the differential current measurements by differential current detector circuit 58. Offset correction detector 24 removes the offset of OTA 28 and preserves the accuracy of the differential current measurements. Another reason this is advantageous is that it allows current transformer 51 to be implemented with fewer windings.

[0029] GFCI module 10 further includes a circuit element parameter measurement network 26 that is comprised of offset correction circuit 24, operational transconductance amplifier (OTA) 28, an in-phase impedance detector 30, and a reactive impedance detector 32. By way of example circuit element parameter measurement network 26 is an impedance measurement network, i.e., the circuit element parameter measured by network 26 is impedance. An inverting input terminal of offset correction circuit 24 is commonly connected to an output terminal 25 of OTA 28 and to a terminal 52 of the primary windings 50 of a current transformer 51 and a non-inverting input terminal of offset correction circuit 24 is connected to a terminal of switch 22. Output terminals of offset correction circuit 24 are connected to corresponding input terminals of OTA 28. More particularly, an output terminal of offset correction circuit 24 is connected to the inverting input terminal of OTA 28 and another output terminal of offset correction circuit 24 is connected to a non-inverting input terminal of OTA 28. A control terminal of switch 22 is coupled for receiving a control signal from digital control circuit 12 and another terminal of switch 22 is coupled for receiving a bias voltage V_{BLAS} and to a terminal 54 of primary windings 50.

[0030] An output terminal 34 of in-phase impedance detector 30 is connected to a ground-neutral (G-N) detector 56 and an output terminal 36 of reactive impedance detector 32 is connected to digital filter 18. Output terminals 34 and 36 serve as output terminals of circuit element parameter measurement network 26. An output terminal 27_J of OTA 28 is connected to an input terminal of differential current detector 58 and an output terminal of differential current detector 58 may be connected to an input terminal of digital filter 18 over a bus connection having P interconnects, where P is an integer. It should be noted that reference character “J” represents an integer and has been appended to reference character 27 to indicate that one or more output terminals, e.g., output terminals 27₁, 27₂, 27₃, etc., may extend from OTA 28. In embodiments in which the electrical signal that is output from OTA 28 is current, it is preferable that each of in-phase impedance detector 30, reactive impedance detector 32, and differential current detector 58 be connected to its own output terminal from OTA 28. For example, when the output signal of OTA 28 is a current, an output terminal 27₁ is connected to in-phase impedance detector 30, an output terminal 27₂ is connected to reactive impedance detector 32, and an output terminal 27₃ is connected to differential current detector 58.

[0031] GFCI module 10 includes sub-modules that are capable of performing an impedance measurement, including a ground-to-neutral resistance measurement and a current transformer reactive impedance measurement, i.e., a self test; a differential current measurement level detection; an OTA offset correction; a ground-to-neutral level detection; a mains/line voltage level detection; stimulus generation; ground-to-neutral detection randomization; digital fault filtering; or the like.

[0032] In accordance with embodiments in which impedance is being measured, waveform stimulus generator 20 creates an electrical signal or waveform that is transmitted to the non-inverting input terminal of offset correction circuit 24 through switch 22. It should be noted that waveform stimulus generator 20 may generate a waveform having a single frequency or a plurality of waveforms having different frequencies from each other. By way of example, to determine whether a true fault has occurred waveform stimulus generator 20 may generate three waveforms each having a different frequency. GFCI 10 includes a voting algorithm to determine when a fault occurs. More particularly, GFCI 10 determines that a fault has occurred based on a majority of the waveform frequencies, e.g., if a fault condition is detected using two out of three of the waveforms, then GFCI 10 indicates the occurrence of a fault. This type of algorithm protects against false trips that may occur if there is a perfectly aligned noise signal on the system.

[0033] Offset correction circuit 24 transmits the electrical signal to the non-inverting input terminal of OTA 28. Because OTA 28 is configured as a follower, the electrical signal at its output terminal 25 follows the electrical signal at its non-inverting input terminal. Thus, the electrical signal appearing at the non-inverting input terminal of OTA 28 is transmitted to output terminal 25 and to input terminal 52 of current transformer 51. Input terminal 54 of current transformer 51 is coupled for receiving a bias voltage V_{BLAS} . OTA 28 creates an electrical signal that is proportional to the electrical signal that appears at output terminal 25 and transmits the proportional electrical signal from output terminals 27_J to in-phase impedance detector 30, quadrature or reactive impedance detector 32, and differential current detector 58. It should be noted that the reference character “J” has been appended to reference character 27 to indicate that one or more output terminals may extend from OTA 28 and provide copies of the current that appears at output terminal 25. As discussed above, when the electrical signal that is output from OTA 28 is current, it is preferable to have output terminals 27₁, 27₂, and 27₃ extending from OTA 28 to in-phase impedance detector 30, reactive impedance detector 32, and differential current detector 58, respectively. Alternatively, output terminals 27₁, 27₂, and 27₃ may be replaced by a single output terminal that is connected to a switch (not shown) that switches the current from the single output terminal between in-phase impedance detector 30, reactive impedance detector 32, and differential current detector 58.

[0034] In-phase impedance detector 30 detects the real component or portion of the impedance of the current transformer load for current transformer 51 and transmits a current or voltage signal to G-N detector 56 that is proportional to this component or portion of the impedance of current transformer 51. G-N detector 56 determines whether the impedance should cause a fault. Reactive or quadrature impedance detector 32 detects the reactive component or portion of the impedance of the current transformer load for current transformer 51 and transmits a current or voltage signal to digital filter 18 that is proportional to this component or a portion of the impedance of current transformer 51. Digital filter 18 determines whether the reactive component is within an acceptable range. For example, a reactive impedance that is too low may indicate that the current transformer is not properly connected to network 26.

[0035] In accordance with an embodiment, differential current measurement may be accomplished by operating switch

22 such that the non-inverting input terminal of offset correction circuit 24 is connected to bias voltage V_{BLAS} . The electrical signal at output terminal 25 is driven to voltage V_{BLAS} by the feedback configuration of OTA 28. In this configuration input terminals 52 and 54 of current transformer 51 are driven to the voltage level V_{BLAS} . Any differential current through the secondary windings of current transformer 51 will induce a current through the primary windings of current transformer 51. The induced current is supplied to output terminal 25 to maintain the voltage at output terminal 25 at the voltage V_{BLAS} . OTA 28 creates or generates a copy of the induced current that is proportional to the induced current at output terminal 27₃, which is transmitted to the input terminal of differential current detector 58. Differential current detector 58 generates an output current that is transmitted to digital filter 18, which determines whether a differential current fault has occurred based on the differential current levels, and the amount of time that the current levels exist.

The filter timing of digital filter 18 may be adjusted dynamically based on the conditions of circuit 10. For example, on initial startup it may be advantageous to minimize the filter timing to quickly catch a wiring fault. However, during normal operation it may be advantageous to increase the filter timing to minimize the effects of noise on the mains line. FIGS. 5 and 6 illustrate the timing of digital filter 18 in accordance with an embodiment of the present invention. FIG. 5 is a timing diagram 43 showing a plot 45 of the relationship between a differential fault current and the time allowed for GFCI module 10 to respond to the fault by opening up the electrical contacts. FIG. 6 illustrates rolling windows for each piecewise linear segment of the differential current that is monitored. More particularly, digital filter 18 is capable of monitoring several states in which GFCI module 10 may be operating. Each state is associated with a different threshold level for identification of a ground fault. During the startup state or phase, a startup fault threshold counter that may be a sub-module within digital filter 18 is programmed to have a startup fault threshold count. During steady state or a steady state phase of operation, digital filter 18 may have a fault threshold counter programmed to have a steady state fault threshold count that is different and preferably higher than the startup fault threshold count during the startup state or phase. It should be noted that the fault threshold counters may be timers such that when a fault exceeds fault threshold for a predetermined period of time, a wiring fault has occurred. The number of states is not limited to being a startup state and steady state. For instance, GFCI module 10 may be operating in a state or phase that is determined by environmental or external conditions. By way of example, GFCI module 10 may be operating in a non-ideal environmental condition such as a brownout condition, i.e., an insufficient power supply voltage, or during a negative half wave, or module 10 may be operating in a condition in which it is undesirable to maintain power to a portion of the circuitry, e.g., the analog portion of the circuitry. Thus, the portion of the circuitry may be powered down. When the brownout condition is over or the portion of the circuitry that was powered down is powered back up, a portion of the output signal from digital filter 18 may be lost. Accordingly, it may be desirable to begin GFCI module 10 so that digital filter 18 is in the startup state, i.e., programmed to have the startup fault threshold count, or digital filter 18 may be programmed to have a fault threshold count that is lower than the startup fault threshold count, lower than the steady state fault thresh-

old count, between the startup fault threshold count and the steady state fault threshold count, or greater than the steady state fault threshold count to meet a specified set of timing requirements. Accordingly, there can be one state, two states, three states, four states, or more states. In addition, the steady state may be comprised of one or more states depending on the circuit configurations and external conditions.

[0036] Although the fault threshold counts have been described as being as comprising a fixed number of counts to trigger a fault, this is not a limitation of the present invention. Alternatively, the fault threshold can be based on a ratio-metric value. For example, the fault threshold may be a ratio of the count of the over-threshold counter to the count of the half wave period counter or the count of the over-threshold counter to the frequency of the mains. An advantage of using a ratio-metric approach is that it provides immunity to AC source variation.

[0037] FIG. 6 illustrates a rolling time window 47 over which a linear segment of plot 45 is monitored for a differential fault current. By way of example, digital filter 18 has four fault threshold counters 53, 55, 57, and 59. However, this is not a limitation of the present invention. There may be P fault threshold counters, where P is an integer. Fault threshold counter 53 is a startup threshold counter. A fault creates fault pulses 61 in rolling time window 47 that have different magnitudes, different pulse widths, and different pulse thresholds. The pulses have different widths for each value of a fault impedance. FIG. 6 also illustrates a fault current waveform 63 with fault threshold count or timing levels Fth-1, Fth-2, . . . , Fth-P. When a minimum threshold of fault time or fault count has been reached, GFCI module 10 indicates that a fault has occurred, i.e., if fault time or count exceeds the fault threshold for a first period of time or number of counts, a wiring fault has occurred. Digital filter 18 monitors GFCI module 10 for a predetermined minimum period of time and if no fault pulse is detected then GFCI module 10 continues in the normal mode of operation. If a fault pulse is detected, GFCI module 10 measures the duration and intensity of the pulse and generates an operating condition signal in accordance with the rate at which the mains level voltage decreases.

[0038] Although the electrical signal generated by OTA 28 and transmitted to differential current detector 58 has been described as a current, this is not a limitation of the present invention. Alternatively, the electrical signal transmitted from OTA 28 may be a voltage that is proportional to the induced current.

[0039] FIGS. 7-14 illustrate embodiments of circuit element parameter measurement networks that are included in GFCI module 10. The circuit element parameter measurement networks of FIGS. 7-14 measure impedances. However, it should be understood this is not a limitation of the present invention. When GFCI module 10 measures impedance and is coupled to a single wound single current transformer, it is referred to as a single wound single current transformer impedance measurement circuit.

[0040] FIG. 7 is a block diagram of a circuit element parameter measurement network 200 in accordance with an embodiment of the present invention. What is shown in FIG. 7 is an Operational Transconductance Amplifier (OTA) 202 having a non-inverting input terminal 204, an inverting input terminal 206, and output terminals 210 and 212. It should be noted that OTA 202 is analogous to OTA 28 shown and described with reference to FIG. 1. Non-inverting input terminal 204 is coupled for receiving an electrical signal $V_{IN}(fc)$

having a frequency fc and inverting input terminal **206** is connected to output terminal **210**. Preferably, electrical input signal $V_{IN}(fc)$ is a voltage signal. More preferably, electrical signal $V_{IN}(fc)$ is a periodic voltage signal such as, for example, a sine wave. It should be noted that electrical signal $V_{IN}(fc)$ may be a DC signal, i.e., frequency fc equals zero. Output terminal **210** of OTA **202** is coupled to a load **216** through a capacitor **214**. By way of example, load **216** is a load impedance that has a circuit element parameter having a real component and a reactive component. For example, when load **216** is an impedance, the impedance has a magnitude and a phase. It should be noted capacitor **214** is an optional circuit element that may be omitted.

[0041] Output terminal **212** of OTA **202** is coupled to modulators **220** and **222** through a current to voltage (I/V) converter **218**. An input terminal **226** of modulator **220** and an input terminal **228** of modulator **222** are connected to an output terminal of I/V converter **218** to form a node **224**. By way of example, I/V converter **218** may be a resistor through which current $I_{rx}(fc)$ flows generating a voltage $V_{rx}(fc)$. Modulator **220** also has an input terminal **230** coupled for receiving a modulation signal $V_s(fc)$ and an output terminal **232** that is connected to an input terminal **234** of a Low Pass Filter (LPF) **236**. Modulation signal $V_s(fc)$ may be a periodic signal such as, for example, a sine wave, a square wave, a saw tooth wave, etc. It should be noted that modulation signal $V_s(fc)$ is the same type of signal as input signal $V_{IN}(fc)$ and has the same frequency as input signal $V_{IN}(fc)$. Preferably, modulation signal $V_s(fc)$ is a sine wave. An Analog-to-Digital Converter (ADC) **238** is connected to an output terminal of LPF **236**. An output signal Z_{MAG216} appears at an output terminal **239** of ADC **238**. Modulator **220** and LPF **236** form an in-phase or real impedance detector **280**.

[0042] Modulator **222** has an input terminal **240** coupled for receiving a modulation signal $V_{SP}(fc)$ through a phase shifting element **244**, and an output terminal **242** coupled to an input terminal **246** of an LPF **248**. Phase shifting element **244** shifts the phase of modulation signal $V_s(fc)$ to produce a phase shifted modulation signal $V_{SP}(fc)$ that has the same frequency and amplitude as modulation signal $V_s(fc)$, but a different phase. For example, signals $V_s(fc)$ and $V_{SP}(fc)$ may have a phase difference of ninety degrees, e.g., signal $V_{SP}(fc)$ is ninety degrees out of phase from signal $V_s(fc)$. An ADC **250** is connected to an output terminal of LPF **248**. An output signal $Z_{PHASE216}$ appears at an output terminal **252** of ADC **250**. Modulator **222** and LPF **248** form a quadrature impedance detector **282**. Quadrature impedance detector **282** is also referred to as an imaginary impedance detector or a reactive impedance detector.

[0043] In operation, input voltage $V_{IN}(fc)$ is applied at input terminal **204** of OTA **202**. In response to input voltage $V_{IN}(fc)$, OTA **202** generates a current $I_{rx}(fc)$ that flows from output terminal **210** through capacitor **214** and into load **216** thereby generating a voltage $V_{rx}(fc)$ at output terminal **210**. Because output terminal **210** is connected to input terminal **206**, voltage $V_{rx}(fc)$ appears at input terminal **206**. Thus, OTA **202** buffers input signal $V_{IN}(fc)$ to load **216**. In addition, OTA **202** generates a copy of current $I_{rx}(fc)$ and conducts this current through output terminal **212**. The copy of current $I_{rx}(fc)$ is labeled current $I_{rx}(fc)$ and is referred to as a copy current or a copied current. Current $I_{rx}(fc)$ is transmitted to I/V converter **218**, which generates a voltage $V_{rx}(fc)$ at node **224**.

[0044] In response to voltages $V_{rx}(fc)$ and $V_s(fc)$, modulator **220** generates an output voltage $V_{MOD_I}(fc)$ at output terminal **232**. Output voltage $V_{MOD_I}(fc)$ is equivalent to the magnitude or the real portion of current $I_{rx}(fc)$ shifted down to the baseband, i.e., shifted down to DC. LPF **236** filters output voltage $V_{MOD_I}(fc)$ to remove any high frequency noise and ADC **238** digitizes the filtered output voltage $V_{MOD_I}(fc)$ to form a digital code Z_{MAG216} that represents the magnitude of the impedance of load **216**, i.e., the digitized signal represents the magnitude of the in-phase component of the impedance of load **216**.

[0045] In response to voltages $V_{rx}(fc)$ and $V_{SP}(fc)$, modulator **222** generates an output voltage $V_{MOD_Q}(fc)$ at output terminal **242**. LPF **248** filters output voltage $V_{MOD_Q}(fc)$ to remove any high frequency noise and ADC **250** digitizes the filtered output voltage $V_{MOD_Q}(fc)$ to form a digital code $Z_{PHASE216}$ that represents the phase of the impedance of load **216**, i.e., the digitized signal represents the quadrature component of the impedance of load **216**.

[0046] FIG. 8 is a schematic diagram of a circuit element parameter measurement network **270** in accordance with another embodiment of the present invention. Network **270** includes OTA **202**, capacitor **214**, load **216**, LPF's **236** and **248**, and ADC's **238** and **250** which have been described above with reference to FIG. 2. In addition, network **270** includes a voltage/current replicator and inverter block **218A** which has an output terminal **217** commonly connected to input terminal **288** of switch **284** and to input terminal **316** of switch **312** to form a node **223** and an output terminal **219** commonly connected to terminal **300** of switch **296** and to terminal **308** of switch **304** to form a node **271**. Network **270** further includes a switch **284** which has a control terminal **286**, a terminal **288** connected to node **223**, and a terminal **290** connected to input terminal **234** of LPF **236**. Control terminal **286** is coupled for receiving modulation signal $V_{SB}(fc)$ through an inverter **292**, i.e., an input terminal of inverter **292** is coupled for receiving modulation signal $V_s(fc)$ and an output terminal of inverter **292** is connected to control terminal **286** of switch **284** for transmitting inverted modulation signal $V_{SB}(fc)$. Node **271** is coupled to input terminal **234** of LPF **236** through a switch **296**, which has a control terminal **298** and terminals **300** and **302**. Control terminal **298** is coupled for receiving modulation signal $V_s(fc)$, terminal **300** is connected to node **271**, and terminal **302** is connected to input terminal **234** of LPF **236**.

[0047] In addition, node **271** is coupled to input terminal **246** of LPF **248** through a switch **304**, which has a control terminal **306** and terminals **308** and **310**. More specifically, control terminal **306** is coupled for receiving modulation signal $V_{SP}(fc)$, terminal **308** is connected to node **271**, and terminal **310** is connected to input terminal **246** of LPF **248**. Switch **312** has a control terminal **314** coupled for receiving modulation signal $V_{SPB}(fc)$ from an inverter **320**, a terminal **316** commonly connected to terminal **288** of switch **284**, and to terminal **217** of current-to-voltage converter **218A**, and a terminal **318** commonly connected to input terminal **246** of LPF **248** and to terminal **310** of switch **304**.

[0048] In operation, input signal $V_{IN}(fc)$ is received at input terminal **204** of OTA **202**. In response to input signal $V_{IN}(fc)$, OTA **202** generates a current $I_{rx}(fc)$ that flows from output terminal **210** through capacitor **214** and into load **216** thereby generating a voltage $V_{rx}(fc)$ at output terminal **210**. Because output terminal **210** is connected to input terminal **206**, voltage $V_{rx}(fc)$ appears at input terminal **206**. Thus, OTA **202** buffers input signal $V_{IN}(fc)$ to load **216**. In addition, OTA **202**

generates a copy of current $I_{rx}(fc)$ and conducts this current through output terminal **212**. The copy of current $I_{rx}(fc)$ is labeled current $I_{rx_I}(fc)$ and is referred to as a copy current or a copied current. Current $I_{rx}(fc)$ is transmitted to I/V converter **218A** and is converted to a voltage $V_{rxp}(fc)$ which appears at node **271** and a voltage $V_{rxn}(fc)$ that appears at node **223**.

[0049] It should be noted that modulation signal $V_S(fc)$ controls switches **284** and **296** and modulation signal $V_{SP}(fc)$ controls switches **304** and **312**. When modulation signal $V_S(fc)$ is at a logic high voltage level switch **284** is closed and switch **296** is open and when modulation signal $V_S(fc)$ is at a logic low voltage level switch **284** is open and switch **296** is closed. When modulation signal $V_{SP}(fc)$ is at a logic high voltage level switch **304** is closed and switch **312** is open and when modulation signal $V_{SP}(fc)$ is at a logic low voltage level switch **304** is open and switch **312** is closed. Thus, switches **284** and **296** are opened and closed to multiply signals $V_{rxn}(fc)$ and $V_{SB}(fc)$ with each other and to multiply signals $V_{rxp}(fc)$ and $V_S(fc)$ with each other. The multiplication of these signals forms product signals that are combined to form voltage signal V_{MOD_I} at input terminal **234** of LPF **236**. Output voltage V_{MOD_I} is equivalent to the magnitude or the real portion of current $I_{rx}(fc)$ shifted down to the baseband, i.e., shifted down to DC. Because signals $V_{rxn}(fc)$ and $V_{rxp}(fc)$ are fully differential signals, the DC component of input signal $V_{rx}(fc)$ is removed, thereby increasing the noise immunity of network **270**. LPF **236** filters output voltage V_{MOD_I} to remove any high frequency noise and ADC **238** digitizes filtered output voltage V_{MOD_I} to form a digital code Z_{MAG216} that represents the magnitude of the impedance of load **216**, i.e., the digitized signal represents the magnitude of the in-phase component of the impedance of load **216**. Switches **284** and **296**, inverter **292**, and LPF **236** form an in-phase or real impedance detector **280A**.

[0050] Similarly, switches **304** and **312** are opened and closed to multiply signals $V_{rxn}(fc)$ and $V_{SPB}(fc)$ with each other and to multiply signals $V_{rxp}(fc)$ and $V_{SP}(fc)$ with each other. The multiplication of these signals forms product signals that are combined to form voltage signal V_{MOD_Q} at input terminal **246** of LPF **248**. LPF **248** filters output voltage V_{MOD_Q} to remove any high frequency noise and ADC **250** digitizes filtered output voltage V_{MOD_Q} to form a digital code $Z_{PHASE216}$ that represents the phase of the impedance of load **216**, i.e., the digitized signal represents the quadrature component of the impedance of load **216**. Switches **304** and **312**, inverter **320**, phase shifting element **244**, and LPF **248** form a quadrature impedance detector **282A**. Quadrature impedance detector **282A** is also referred to as an imaginary impedance detector or a reactive impedance detector.

[0051] FIG. **9** is a schematic diagram of a circuit element parameter measurement network **350** in accordance with another embodiment of the present invention. What is shown in FIG. **9** is OTA **202A** coupled to load **216** through capacitor **214**. OTA **202A** is similar to OTA **202** but has three output terminals **210**, **212**, and **215** rather than the two output terminals **210** and **212** of OTA **202**. Because OTA **202A** has three output terminals, reference character "A" has been appended to reference character "202" to distinguish between OTA **202** of FIG. **2** and the operational transconductance amplifier of FIG. **8**. Similar to network **270** described with reference to FIG. **7**, output **210** of OTA **202A** is coupled to load **216** through capacitor **214**. Network **350** includes node **223** coupled to input terminal **234** of LPF **236** through a switch **284** and to an output terminal **217A** of current-to-voltage

converter **218A**. More particularly, switch **284** has a control terminal **286**, a terminal **288** connected to node **223**, and a terminal **290** connected to input terminal **234** of LPF **236**. Control terminal **286** is coupled for receiving modulation signal $V_{SB}(fc)$ from an inverter **292**, i.e., an input terminal of inverter **292** is coupled for receiving modulation signal $V_S(fc)$ and an output terminal of inverter **292** is connected to control terminal **286** of switch **284** for transmitting an inverter modulation signal $V_{SB}(fc)$. Input terminal **234** of LPF **236** is coupled to output terminal **219A** of current-to-voltage converter **218A** through a switch **296**, which has a control terminal **298** and terminals **300** and **302**. Control terminal **298** is coupled for receiving modulation signal $V_S(fc)$, terminal **300** is connected to output terminal **219A** of current-to-voltage converter **218A**, and terminal **302** is commonly connected to input terminal **234** of LPF **236** and to terminal **290** of switch **284**.

[0052] Output terminal **215** of OTA **202A** is coupled to LPF **248** through a switch **312** and a current-to-voltage converter **218B**. More particularly, output terminal **215** is connected to an input terminal of current-to-voltage converter **218B** and an output terminal **217B** of current-to-voltage converter **218B** is connected to terminal **316** to form a node **223A**. An output terminal **219B** of current-to-voltage converter **218B** is connected to a terminal **308** of switch **304**. Switch **304** also has a control terminal **306** coupled for receiving modulation signal $V_{SP}(fc)$ and a terminal **310** commonly connected to input terminal **246** of LPF **248** and to a terminal **318** of switch **312**. Output terminal **217B** is coupled to input terminal **246** of LPF **248** and to terminal **310** of switch **304** through switch **312**. More particularly, switch **312** has a control terminal **314**, a terminal **316** connected to output terminal **217B**, and a terminal **318** commonly connected to input terminal **246** of LPF **248** and to terminal **310** of switch **304**. Control terminal **314** is coupled for receiving modulation signal $V_{SPB}(fc)$ from inverter **320**, i.e., an input terminal of inverter **320** is coupled for receiving modulation signal $V_{SP}(fc)$ and an output terminal of inverter **320** is connected to terminal **314** of switch **312** for transmitting inverted modulation signal $V_{SPB}(fc)$.

[0053] In operation, input voltage $V_{IN}(fc)$ is applied at input terminal **204** of OTA **202A**. In response to input voltage $V_{IN}(fc)$, OTA **202A** generates a current $I_{rx}(fc)$ that flows from output terminal **210** through capacitor **214** and into load **216** thereby generating a voltage $V_{rx}(fc)$ at output terminal **210**. Because output terminal **210** is connected to input terminal **206**, voltage $V_{rx}(fc)$ appears at input terminal **206**. Thus, OTA **202A** buffers input signal $V_{IN}(fc)$ to load **216**. In addition, OTA **202** generates copies $I_{rx_I}(fc)$ and $I_{rx_Q}(fc)$ of current $I_{rx}(fc)$ and conducts the currents $I_{rx_I}(fc)$ and $I_{rx_Q}(fc)$ through output terminals **212** and **215**, respectively. The copies of current $I_{rx}(fc)$ are labeled $I_{rx_I}(fc)$ and $I_{rx_Q}(fc)$ and each current is referred to as a copy current or a copied current. Current $I_{rx_I}(fc)$ is transmitted to current-to-voltage converter **218A** which generates a voltage signal $V_{rxp_I}(fc)$ at node **223**. Current $I_{rx_Q}(fc)$ is transmitted to current-to-voltage converter **218B** which generates a voltage signal $V_{rxp_Q}(fc)$ at node **223A**.

[0054] It should be noted that modulation signal $V_S(fc)$ controls switches **284** and **296** and modulation signal $V_{SP}(fc)$ controls switches **304** and **312**. When modulation signal $V_S(fc)$ is at a logic high voltage level switch **284** is closed and switch **296** is open and when modulation signal $V_S(fc)$ is at a logic low voltage level switch **284** is open and switch **296** is closed. When modulation signal $V_{SP}(fc)$ is at a logic high

voltage level switch **304** is closed and switch **312** is open and when modulation signal $V_{SP}(fc)$ is at a logic low voltage level switch **304** is open and switch **312** is closed. Thus, switches **284** and **296** are opened and closed to multiply signals $V_{rxm_I}(fc)$ and inverted signal $V_{SB}(fc)$ with each other and to multiply signal $V_{rxp_I}(fc)$ and $V_S(fc)$ with each other. The multiplication of these signals forms product signals that are combined to form voltage signal V_{MOD_I} at input terminal **234** of LPF **236**. Output voltage V_{MOD_I} is equivalent to the magnitude or the real portion of current $I_{rx}(fc)$ shifted down to the baseband, i.e., shifted down to DC. Because signals $V_{rxm_I}(fc)$ and $V_{rxp_I}(fc)$ are fully differential signals, the DC component of input signal $V_{IN}(fc)$ is removed, thereby increasing the noise immunity of network **350**. LPF **236** filters output voltage V_{MOD_I} to remove any high frequency noise and ADC **238** digitizes filtered output voltage V_{MOD_I} to form a digital code Z_{MAG216} at output terminal **239** that represents the magnitude of the impedance for load **216**, i.e., the digitized signal represents the magnitude of the in-phase component of the impedance of load **216**.

[0055] Similarly, switches **304** and **312** are opened and closed to multiply signals $V_{rxm_Q}(k)$ and inverted signal $V_{SPB}(fc)$ with each other and to multiply signal $V_{rxp_Q}(fc)$ and $V_{SP}(fc)$ with each other. The multiplication of these signals forms product signals that are combined to form voltage signal V_{MOD_Q} at input terminal **246** of LPF **248**. LPF **248** filters output voltage V_{MOD_Q} to remove any high frequency noise and ADC **250** digitizes filtered output voltage V_{MOD_Q} to form a digital code $Z_{PHASE216}$ at output terminal **252** that represents the phase of the impedance for load **216**, i.e., the digitized signal represents the quadrature component of the impedance of load **216**.

[0056] FIG. **10** is a schematic diagram of a circuit element parameter measurement network **370** in accordance with another embodiment of the present invention. Network **370** is similar to network **200** except that OTA **202** is replaced with OTA **202A** and current-to-voltage converter **218** is absent from network **370**. In addition, modulators **220** and **222** are replaced with modulators **220A** and **222A** which are configured to receive current rather than a voltage. The operation of network **370** is similar to that of network **200** except that mixers **220A** and **222A** mix currents rather than voltages. Modulator **220A** and LPF **236** form an in-phase or real impedance detector **280B**. Modulator **222A** and LPF **248** form a quadrature impedance detector **282B**. Quadrature impedance detector **282B** is also referred to as an imaginary impedance detector or a reactive impedance detector.

[0057] FIG. **11** is a schematic diagram of a circuit element parameter measurement network **400** in accordance with another embodiment of the present invention. What is shown in FIG. **11** is OTA **202A** coupled to load **216** through capacitor **214**. The configuration of network **400** is similar to that of network **350** except that switches **284** and **296** and inverter **292** are replaced by a Digital-to-Analog Converter (DAC) **402** and switches **304** and **312** and inverter **320** are replaced by a DAC **404**. More particularly, DAC **402** has an input terminal **406** connected to output terminal **212** of OTA **202A**, an input terminal **408** coupled for receiving an input signal $D_{SIN}[N:0]$, and an output terminal **410** connected to input terminal **234** of LPF **236**. DAC **404** has an input terminal **412** connected to output terminal **215** of OTA **202A**, an input terminal **414** coupled for receiving an input signal $D_{COS}[N:0]$

and an output terminal **416** connected to input terminal **246** of LPF **248**. Signals $D_{SIN}[N:0]$ and $D_{COS}[N:0]$ are also referred to as digital codes.

[0058] In operation, input voltage $V_{IN}(fc)$ is applied at input terminal **204** of OTA **202A**. In response to input voltage $V_{IN}(fc)$, OTA **202A** generates a current $I_{rx}(fc)$ that flows from output terminal **210** through capacitor **214** and into load **216** thereby generating a voltage $V_{rx}(fc)$ at output terminal **210**. Because output terminal **210** is connected to input terminal **206**, voltage $V_{rx}(fc)$ appears at input terminal **206**. Thus, OTA **202A** buffers input signal $V_{IN}(fc)$ to load **216**. In addition, OTA **202** generates copies $I_{rx_I}(fc)$ and $I_{rx_Q}(fc)$ of current $I_{rx}(fc)$ and conducts the currents $I_{rx_I}(fc)$ and $I_{rx_Q}(fc)$ through output terminals **212** and **215**, respectively. The copies of current $I_{rx}(fc)$ are labeled $I_{rx_I}(fc)$ and $I_{rx_Q}(fc)$ and each current is referred to as a copy current or a copied current. Current $I_{rx_I}(fc)$ is transmitted to DAC **402** which modulates current $I_{rx_I}(fc)$ by digital input code $D_{SIN}[N:0]$ and generates a voltage V_{MOD_I} that appears at output terminal **410**. LPF **236** filters output voltage V_{MOD_I} to remove any high frequency noise and ADC **238** digitizes filtered output voltage V_{MOD_I} to form a digital code Z_{MAG216} at output terminal **239** that represents the magnitude of the impedance of load **216**, i.e., the digitized signal represents the magnitude of the in-phase component of the impedance of load **216**.

[0059] Current $I_{rx_Q}(fc)$ is transmitted to DAC **404** which modulates current $I_{rx_Q}(fc)$ by digital input code $D_{COS}[N:0]$ and generates a voltage V_{MOD_Q} that appears at output terminal **416**. LPF **248** filters output voltage V_{MOD_Q} to remove any high frequency noise and ADC **250** digitizes filtered output voltage V_{MOD_Q} to form a digital code $Z_{PHASE216}$ at output terminal **252** that represents the phase of the impedance of load **216**, i.e., the digitized signal represents the quadrature component of the impedance of load **216**.

[0060] It should be noted that network **400** has been shown as modulating currents $I_{rx_I}(fc)$ and $I_{rx_Q}(fc)$ using sinusoidal current input codes. However, currents $I_{rx_I}(fc)$ and $I_{rx_Q}(fc)$ may be converted to voltage signals so that DAC's **402** and **404** modulate voltage signals using sinusoidal digital voltage input codes, i.e., in this embodiment digital codes $D_{SIN}[N:0]$ and $D_{COS}[N:0]$ are digital voltage signals.

[0061] FIG. **12** is a schematic diagram of a circuit element parameter measurement network **500** in accordance with another embodiment of the present invention. Network **500** includes OTA **202**, capacitor **214**, and load **216** which have been described above with reference to FIG. **2**. In addition, network **500** includes a bandpass filter **502** having an input terminal **504** connected to output terminal **212** of OTA **202** and an output terminal **506** connected to an input terminal **512** of an Analog-to-Digital Converter (ADC) **510**. ADC **510** has an output terminal **514** connected to modulators **520** and **522**. An input terminal **524** of modulator **520** and an input terminal **526** of modulator **522** are connected to output terminal **514** to form a node **528**. Modulator **520** also has an input terminal **530** coupled for receiving a modulation signal $V_S(n)$ and an output terminal **532** connected to an input terminal **536** of a Low Pass Filter (LPF) **534**. Modulation signal $V_S(n)$ may be a digitized periodic signal such as, for example, a sine wave, a square wave, a saw tooth wave, etc. Preferably, modulation signal $V_S(n)$ is a digitized sine wave. It should be noted that modulation signal $V_S(n)$ is the same type of signal as input

signal $V_{IN}(fc)$ and has the same frequency as input signal $V_{IN}(fc)$. An output signal Z_{MAG216} appears at an output terminal 539 of LPF 534, where output signal Z_{MAG216} represents the magnitude of the impedance for load 216, i.e., the digitized signal represents the magnitude of the in-phase component of the impedance of load 216. Modulator 520 and LPF 534 form an in-phase or real impedance detector 280C.

[0062] Modulator 522 has an input terminal 529 coupled for receiving a modulation signal $V_{SP}(n)$ through a phase shifting element 544, and an output terminal 527 coupled to an input terminal 540 of a LPF 536. Phase shifting element 544 shifts the phase of modulation signal $V_S(n)$ to produce a phase shifted modulation signal $V_{SP}(n)$ that has the same frequency and amplitude as modulation signal $V_S(n)$, but a different phase. For example, signals $V_S(n)$ and $V_{SP}(n)$ may have a phase difference of ninety degrees, e.g., signal $V_{SP}(n)$ is ninety degrees out of phase from signal $V_S(n)$. An output signal $Z_{PHASE216}$ appears at an output terminal 552 of LPF 536, where output signal $Z_{PHASE216}$ represents the phase of the impedance for load 216, i.e., the digitized signal represents the quadrature component of the impedance of load 216. Modulator 522 and LPF 536 form a quadrature impedance detector 282C. Quadrature impedance detector 282C is also referred to as an imaginary impedance detector or a reactive impedance detector.

[0063] FIG. 13 is a schematic diagram of a circuit element parameter measurement network 430 in accordance with another embodiment of the present invention. What is shown in FIG. 13 is OTA 202A having input terminals 204 and 206 and output terminals 210, 212, and 215. Input terminal 204 is coupled for receiving an input signal $V_{IN}(fc)$ and input terminal 206 is coupled to output terminal 210, which is connected to an input/output node 431. Output terminal 215 is coupled to an input/output node 433 through a switch 432 and output terminal 212 is coupled to input/output node 433 through a switch 440. More particularly, switch 432 has a control terminal 434 coupled for receiving an input signal $V_S(fc)$ through an inverter 448, a terminal 436 connected to output terminal 215, and a terminal 438 connected to input/output node 433. Inverter 448 inverts signal $V_S(fc)$ to generate a signal $V_{S,B}(fc)$ which appears at terminal 434. Switch 440 has a control terminal 442 coupled for receiving input signal $V_S(fc)$, a terminal 444 connected to output terminal 212 and a terminal 446 connected to input/output node 433 and to terminal 438 of switch 432.

[0064] Network 430 further includes an operational amplifier 450 having a non-inverting input terminal 452, an inverting input terminal 454, and an output terminal 456, where non-inverting input terminal 452 is coupled for receiving a bias signal V_{BIAS} and inverting input terminal 454 is coupled to output terminal 456 and to an input/output node 435. Output terminal 456 of operational amplifier 450 is coupled to output terminals 438 and 446 and to input/output node 433 through a resistor 458. A filtering capacitor 460 is connected between input/output node 433 and input/output node 435. In addition, input/output nodes 431 and 435 are connected to terminals 462 and 464 of a current transformer 466. Preferably, current transformer 466 is a single wound single current transformer circuit. Although resistor 458 and filtering capacitor 460 have been shown as a resistor and a capacitor that are external to a semiconductor chip from which OTA 202A, operational amplifier 450, and switches 432 and 440, and inverter 448 are manufactured, this is not a limitation of the present invention. Resistor 458 may be an on-chip resis-

tor, filtering capacitor 460 may be an on-chip capacitor, or one of resistor 458 and filtering capacitor 460 may be a filtering capacitor. It should be noted that input/output nodes 431, 433, and 435 may be input/output pins of a package semiconductor chip.

[0065] In operation, a sinusoidal signal $V_{IN}(fc)$ is applied to input terminal 204. In response to sinusoidal input signal $V_{IN}(fc)$, OTA 202A generates a current $I_x(fc)$ that flows from output terminal 210 to terminal 462 of current transformer 466. In addition, OTA 202A generates copies $I_{ix}(fc)$ and $I_{ix}(fc)$ of current $I_x(fc)$ and conducts the currents $I_{ix}(fc)$ and $I_{ix}(fc)$ through output terminals 212 and 215, respectively. Voltage V_{BIAS} is connected to input terminal 452 of operational amplifier 450 and is transmitted to output terminal 456. Bias voltage V_{BIAS} is transmitted to terminal 464 of current transformer 466. Switches 432 and 440 are opened and closed in accordance with input voltage $V_S(fc)$ that is input to control terminal 442.

[0066] FIG. 14 is a schematic diagram of a circuit element parameter measurement network 470 in accordance with another embodiment of the present invention. What is shown in FIG. 14 is OTA 202A, operational amplifier 450, and switches 432 and 440. Output terminal 210 is connected to an input/output node 492 which is connected to a terminal 496 of current transformer 497 through a series connected resistor 493 and capacitor 494. It should be noted that capacitor 494 is an optional component that may be omitted. The connection of output terminals 212 and 215 and switches 432 and 440 have been described with reference to network 430 shown in FIG. 13. It should be noted that the connection of terminals 438 and 440 of switches 432 and 440, respectively, are different from that described above with reference to FIG. 13 and will be described below.

[0067] Network 470 further includes an operational amplifier 472 having a non-inverting input terminal 474 coupled to an output terminal 478 through a resistor 480. Output terminal 478 is coupled to an input/output node 490 through a resistor 308. Input/output node 490 is coupled to ground through, for example, a capacitor 498. Operational amplifier 472 has an inverting input terminal 476 commonly connected to output terminal 456, input/output node 435, and terminal 496. Terminals 438 and 446 of switches 432 and 440, respectively, are commonly connected to terminal 486 of switch 482 and to non-inverting input terminal 474. Switch 482 has a control terminal 499 coupled for receiving input signal V_{CNTL} , a terminal 484 connected to node 491, and a terminal 486 commonly connected to non-inverting input terminal 474 of operational amplifier 472 and to terminal 438 of switch 432. A terminal of resistor 493, a terminal of capacitor, and a terminal 495 of current transformer 497 of current transformer 497. The other terminal of capacitor 494 is commonly connected to input/output pad 435 and to input terminal 496 of current transformer 497. Preferably, current transformer 497 is a single wound single current transformer circuit. Input/output pads 435, 490, 491, and 492 may be input/output pins of a packaged semiconductor chip.

[0068] Although specific embodiments have been disclosed herein, it is not intended that the invention be limited to the disclosed embodiments. Those skilled in the art will recognize that modifications and variations can be made without departing from the spirit of the invention. It is intended that the invention encompass all such modifications and variations as fall within the scope of the appended claims.

What is claimed is:

1. A single wound single current transformer impedance measurement circuit for determining a circuit element parameter, comprising:

a transconductance amplifier having first and second input terminals and first and second output terminals;

a first detector having first and second input terminals and an output terminal, the first input terminal of the first detector coupled to the first output terminal of the transconductance amplifier and the second input terminal of the first detector coupled for receiving a first electrical signal; and

a second detector having first and second input terminals and an output terminal, the first input terminal of the second detector coupled to the second output terminal of the transconductance amplifier.

2. The single wound single current transformer impedance measurement circuit of claim 1, wherein the first detector detects a real part of an impedance and the second detector detects an imaginary part of the impedance.

3. The single wound single current impedance measurement circuit of claim 1, wherein

the first detector comprises:

a first modulator having an output terminal and first and second input terminals that serve as the first and second input terminals of the first detector;

a first low pass filter having an input terminal and an output terminal, the input terminal of the first low pass filter coupled to the output terminal of the first modulator, and wherein the second detector comprises:

a second modulator having an output terminal and first and second input terminals, wherein the first input terminal of the second modulator serves as the first input terminal of the second detector; and

a second low pass filter having an input terminal and an output terminal, the input terminal of the second low pass filter coupled to the output terminal of the second modulator.

4. The single wound single current impedance measurement circuit of claim 3, further including a single wound single current transformer circuit having first and second terminals, the first terminal of the single wound single current transformer circuit coupled to the output terminal of the transconductance amplifier.

5. The single wound single current impedance measurement circuit of claim 3, wherein the second detector further includes a phase shifting element having an input terminal and an output terminal, the output terminal of the phase shifting element coupled to the second input terminal of the second modulator and the input terminal of the phase shifting element serving as the second input terminal of the second detector.

6. The single wound single current impedance measurement circuit of claim 3, further including:

a first converter having an input terminal and an output terminal, the input terminal of the first converter coupled to the output terminal of the first low pass filter; and

a second converter having an input terminal and an output terminal, the input terminal of the second converter coupled to the output terminal of the second low pass filter.

7. The single wound single current impedance measurement circuit of claim 6, wherein the first converter is an analog to digital converter and the second converter is an analog to digital converter.

8. The single wound single current impedance measurement circuit of claim 1, wherein

the first detector comprises:

a first switch having a control terminal and first and second conduction terminals;

a second switch having a control terminal and first and second conduction terminals, wherein the first conduction terminal of the second switch is coupled to the first conduction terminal of the second switch; and

a first inverter having an input terminal and an output terminal, the input terminal of the first inverter coupled to the control terminal of the second switch and the output terminal of the first inverter coupled to the control terminal of the first switch; and

a first low pass filter having an input terminal and an output terminal, the input terminal of the first low pass filter coupled to the first conduction terminals of the first switch and the second switches; and wherein the second detector comprises:

a third switch having a control terminal and first and second conduction terminals;

a fourth switch having a control terminal and first and second conduction terminals, wherein the first conduction terminal of the fourth switch is coupled to the first conduction terminal of the third switch; and

a second inverter having an input terminal and an output terminal, the input terminal of the second inverter coupled to the control terminal of the fourth switch and the output terminal of the second inverter coupled to the control terminal of the third switch; and

a second low pass filter having an input terminal and an output terminal, the input terminal of the second low pass filter coupled to the first conduction terminals of the third switch and the fourth switches.

9. The single wound single current impedance measurement circuit of claim 8, further including:

a first converter having a first input terminal, a first output terminal, and a second output terminal, the first input terminal of the first converter coupled to the first output terminal of the transconductance amplifier, the first output terminal of the first converter coupled to the second conduction terminal of the first switch, and the second output terminal of the first converter coupled to the second conduction terminal of the second switch; and

a second converter having a first input terminal, a first output terminal, and a second output terminal, the first input terminal of the second converter coupled to the second output terminal of the transconductance amplifier, the first output terminal of the second converter coupled to the second conduction terminal of the third switch, and the second output terminal of the second converter coupled to the second conduction terminal of the fourth switch.

10. The single wound single current impedance measurement circuit of claim 9, wherein the first converter is a current to voltage converter and the second converter is a current to voltage converter.

11. The single wound single current impedance measurement circuit of claim 9, wherein the second detector further includes a phase shifting element having an input and an

output, the output of the phase shifting element coupled to the control terminal of the third switch and to the control terminal of the fourth switch.

12. The single wound single current impedance measurement circuit of claim **11**, further including:

a third converter having an input terminal and an output terminal, the input terminal of the third converter coupled to the output terminal of the first low pass filter; and

a fourth converter having an input terminal and an output terminal, the input terminal of the fourth converter coupled to the output terminal of the second low pass filter.

13. The single wound single current impedance measurement circuit of claim **12**, further including a single wound single current transformer circuit having first and second terminals, the first terminal of the single wound single current transformer circuit coupled to the output terminal of the transconductance amplifier.

14. A single wound single current transformer impedance measurement circuit for determining a circuit element parameter, comprising:

a transconductance amplifier having first and second inputs and first and second outputs, the first output of the transconductance amplifier coupled to a first node;

a first switch having a control terminal and first and second conduction terminals, the first conduction terminal of the first switch coupled to the first output of the transconductance amplifier;

a second switch having a control terminal and first and second conduction terminals, the first conduction terminal of the second switch coupled to the second output of the transconductance amplifier, the second conduction terminal of the second switch coupled to the second conduction terminal of the first switch;

an inverter having an input and an output, the input of the inverter coupled to the control terminal of the second switch and the output of the inverter coupled to the control terminal of the first switch; and

a first operational amplifier having first and second inputs and an output, the output of the first operational amplifier coupled to a second node and to the second input of the first operational amplifier.

15. The single wound single current transformer impedance measurement circuit for determining a circuit element parameter of claim **14**, wherein the second terminals of the first and second switches are coupled to a third node, and further including:

a resistor coupled between the second and third nodes; and
a capacitor coupled between the second and third nodes.

16. The single wound single current transformer impedance measurement circuit for determining a circuit element parameter of claim **14**, further including a single wound current transformer circuit having first and second terminals, the first terminal of the single wound current transformer circuit coupled to the first node and the second terminal of the single wound current transformer circuit coupled to the second node.

17. The single wound single current transformer impedance measurement circuit for determining a circuit element parameter of claim **16**, further including:

a second operational amplifier having first and second inputs and an output, the output of the second operational amplifier coupled to a third node;

a third switch having a control terminal and first and second conduction terminals, the first conduction terminal of the third switch coupled to the first input of the second operational amplifier, the second conduction terminal of the third switch coupled to the first terminal of the single wound single current transformer;

a first resistor coupled between the first node and the first terminal of the single wound single current transformer; and

a first capacitor coupled between the first and second terminals of the single wound single current transformer circuit.

18. The single wound single current transformer impedance measurement circuit for determining a circuit element parameter of claim **17**, further including:

a second resistor coupled between the first input of the second operational amplifier and the output of the operational amplifier; and

a third resistor coupled between the output of the second operational amplifier and the third node; and
a second capacitor coupled to the third node.

19. A single wound single current transformer impedance measurement circuit for determining a circuit element parameter, comprising:

a transconductance amplifier having first and second input terminals and first and second output terminals;

a first detector having first and second input terminals and an output terminal, the first input terminal coupled to the first output terminal of the transconductance amplifier and the second input terminal coupled for receiving a first electrical signal; and

a second detector having first and second input terminals and an output terminal, the first input terminal coupled to the first output terminal of the transconductance amplifier.

20. The single wound single current transformer impedance measurement circuit for determining a circuit element parameter of claim **19**, further including:

a band pass filter having an input terminal and an output terminal, the input terminal of the band pass filter coupled to the first output terminal of the transconductance amplifier; and

an analog to digital converter having an input terminal and an output terminal, the input terminal of the analog to digital converter coupled to the first output terminal of the transconductance amplifier and the output terminal of the analog to digital converter coupled to the first input terminal of the first detector and to the first input terminal of the second detector.

* * * * *