

A. McMURTRIE.
HANGER FOR ELECTRIC OUTLET BOXES.
APPLICATION FILED JAN. 15, 1906.

935,319.

Patented Sept. 28, 1909.

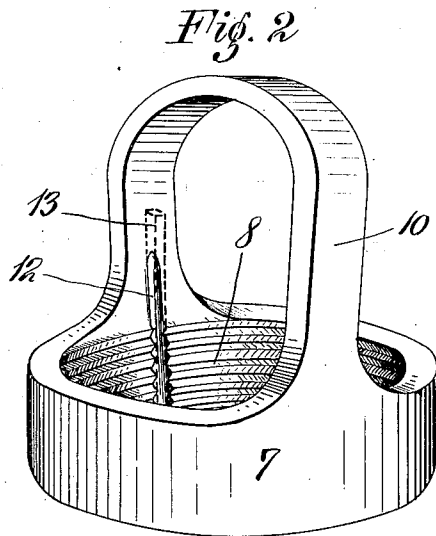
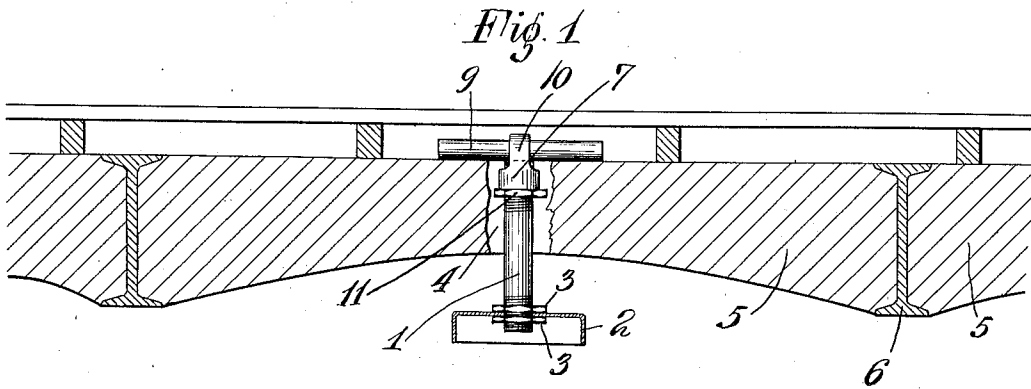

Witnesses
J. A. Henningsberg
Harry H. Walton

A. McMurtie Inventor
By his Attorney
Alexander P. Croudfit.

UNITED STATES PATENT OFFICE.

ADNAH McMURTRIE, OF NEW YORK, N. Y., ASSIGNOR TO THOMAS & BETTS COMPANY,
OF NEW YORK, N. Y., A CORPORATION OF NEW YORK.

HANGER FOR ELECTRICAL OUTLET-BOXES.

935,319.

Specification of Letters Patent. Patented Sept. 28, 1909.

Application filed January 15, 1906. Serial No. 296,036.

To all whom it may concern:

Be it known that I, ADNAH McMURTRIE, of New York, N. Y., have invented certain Improvements in Hangers for Electrical Outlet-Boxes and the Like, of which the following description, in connection with the accompanying drawings, is a specification, like numerals on the drawings designating like parts.

10 This invention relates to supporting devices or "hangers" for outlet boxes and similar members of electrical conduit systems and is of special utility when applied to ceiling boxes, although I contemplate its use in any field for which it may be adapted by the nature of my improvements.

15 The principal feature of the device is found in the means to enable the ready application of the hanger to a floor in which a hole has been made to permit the passage of the hanger, these holes being, in the case of fire-proof construction more particularly, uneven and often unnecessarily large for the hanger, so that the ordinary forms of pipe fittings are not suitable. It has been the custom to use large plates bridging the hole and from which the hangers depend, but this form of support is unnecessarily expensive, and not easy to install. By my invention I provide a simple fitting, easily handled with ordinary pipe fitters' tools, and not requiring any special work or previous preparation.

20 The various features of my invention will be illustrated and described fully in the accompanying drawing and specification and pointed out in the claims.

25 In the drawings, Figure 1 shows in section, and partly in elevation, a portion of a ceiling structure with a hanger and outlet box in place, according to my invention; while Fig. 2 is a view in perspective on an enlarged scale of a portion of one member of the hanger device taken separately.

30 In the embodiment of my invention selected for illustration and description as a convenient form to enable a ready and complete understanding of my improvements, the part designated by the reference numeral 1 is the "hanger" proper and may be of any convenient and suitable form, being in this instance a section of pipe, to the lower end of which a ceiling or outlet box 2 is secured in the usual manner by lock-nuts as at 3. The upper end of the pipe having been thrust up through a hole 4

in the floor, of which that chosen for illustration is ordinary fire-proof construction comprising members 5, supported by beams 6, a connecting member 7, best seen in Fig. 2, is secured to the upper end of the hanger by means of the threaded aperture 8, a supporting member 9 is passed through the loop 10 of the connecting member, and the upper end of the hanger pipe is screwed home snugly against the supporting member, binding it in place and preventing its accidental displacement, so that it bridges the opening 4 in the floor and causes the hanger to be retained in place supporting the outlet box, and thereafter the plaster may be applied around the hanger and box, and the floor boards, &c., placed above the hanger itself.

60 The various members may be formed of any suitable material, including the connecting member, the form of which may be varied somewhat without departing from my invention, but I prefer to make it in the form illustrated for the sake of lightness and easy assembly of the several members.

65 Means, such as the lock-nut 11, may be provided to prevent rotation of the hanger member when in place, or a groove 12 in the connecting member 7 may be provided to receive a wedge, as 13 shown in dotted lines, Fig. 2.

70 Having thus illustrated and described my invention and one means of carrying the same into effect it will be understood that I do not limit myself to the specific form illustrated, nor in general otherwise than as set forth in the claims read in connection with this specification.

75 What I claim and desire to secure by Letters Patent is:—

80 1. A hanger device for outlet boxes or the like comprising a supporting member, a connecting member having a portion to receive and be supported by said supporting member, and a hanging member to receive and support said box, said hanging member being secured to said connecting member and arranged to engage the supporting member and secure the same against displacement from said connecting member, substantially as described.

85 2. A hanger device for outlet boxes or the like comprising a supporting member, a connecting member, and a hanging member, said hanging member being secured to the connecting member and arranged to engage

the supporting member and secure the same against displacement, and means to secure said hanging member and connecting member in adjusted position.

- 5 3. A device of the class described comprising a connecting member having a threaded aperture to receive a hanger member and having a loop portion to receive a supporting member, the opening of said
10 loop being at an angle to said threaded aperture so that said hanger member is driven by insertion of its threaded end within said threaded aperture to bind said supporting member in place, substantially as described.
- 15 4. As an article of manufacture; an interiorly threaded annular member constructed and arranged to pass and be seated upon the threaded periphery of the article to be secured, such as a pipe; and an integral loop
20 portion extending at an angle to said annular member in position to pass the article to which attachment is to be effected, said loop being of sufficient size to permit free
25 traversal by said articles into binding contact with each other, and open to permit

inspection of said region of contact; substantially as described.

5. A device of the class described comprising a connecting member having a threaded aperture to receive a hanger member and having a loop portion to receive a supporting member, the opening of said loop being at an angle to said threaded aperture so that said hanger member is driven by insertion of its threaded end within said threaded aperture to bind said supporting member in place, the threads of said threaded aperture being interrupted transversely, as at 12, to form a seat for a key to be inserted after said hanger member is in place, and to hold said parts against accidental displacement.

Signed at New York in the county of New York and State of New York this 27th day of December A. D. 1905.

ADNAH McMURTRIE.

Witnesses:

ALEXANDER C. PROUDFIT,
WM. H. McCORMICK.