



US 20210246770A1

(19) **United States**

(12) **Patent Application Publication**
Shaw

(10) **Pub. No.: US 2021/0246770 A1**

(43) **Pub. Date: Aug. 12, 2021**

(54) **HYBRID GAS LIFT SYSTEM**

Publication Classification

(71) Applicant: **Silverwell Technology Ltd.**, Histon
(GB)

(51) **Int. Cl.**
E21B 43/12 (2006.01)
E21B 47/06 (2006.01)
E21B 34/16 (2006.01)

(72) Inventor: **Joel David Shaw**, Houston, TX (US)

(52) **U.S. Cl.**
CPC *E21B 43/123* (2013.01); *E21B 34/16*
(2013.01); *E21B 47/06* (2013.01)

(73) Assignee: **Silverwell Technology Ltd.**, Histon
(GB)

(57) **ABSTRACT**

(21) Appl. No.: **17/171,211**

Liquid is unloaded from a well with a hybrid gas lift system that includes a lift gas source and valves for injecting lift gas into production tubing. The types of valves include pressure production operated ("PPO") valves and a surface operated valve. Pressure inside the production tubing is measured to monitor operation of the PPO valves, and identify if the PPO valves are experiencing an anomaly, such as multi-pointing or chattering. The surface operated valve is selectively actuated to correct anomalous operation of the PPO valves.

(22) Filed: **Feb. 9, 2021**

Related U.S. Application Data

(60) Provisional application No. 62/972,421, filed on Feb. 10, 2020.

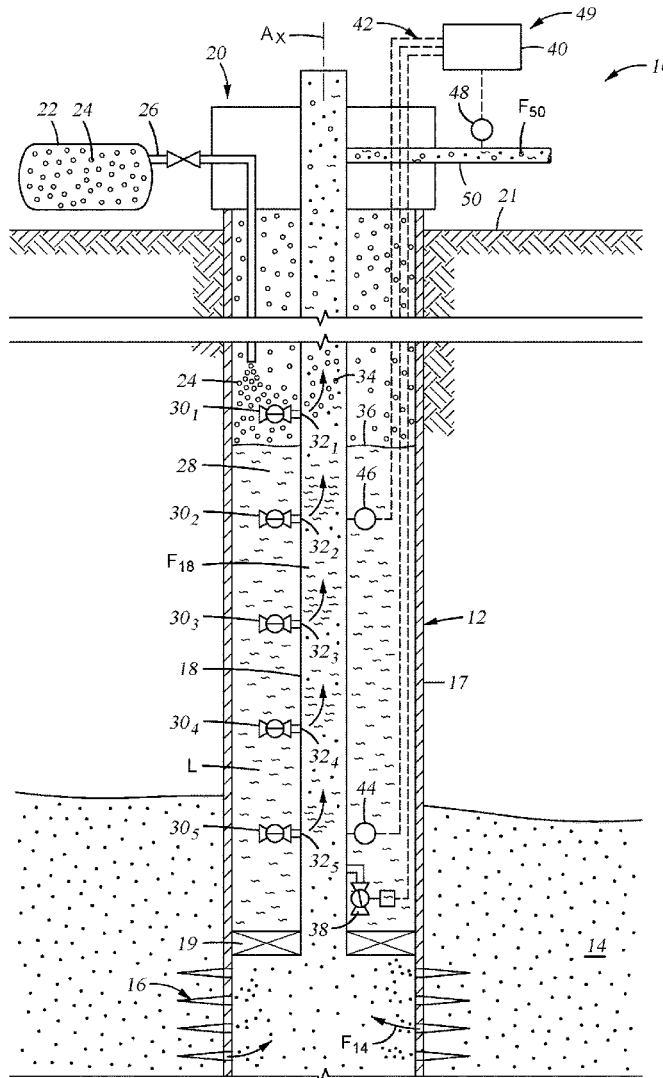

Fig. 1

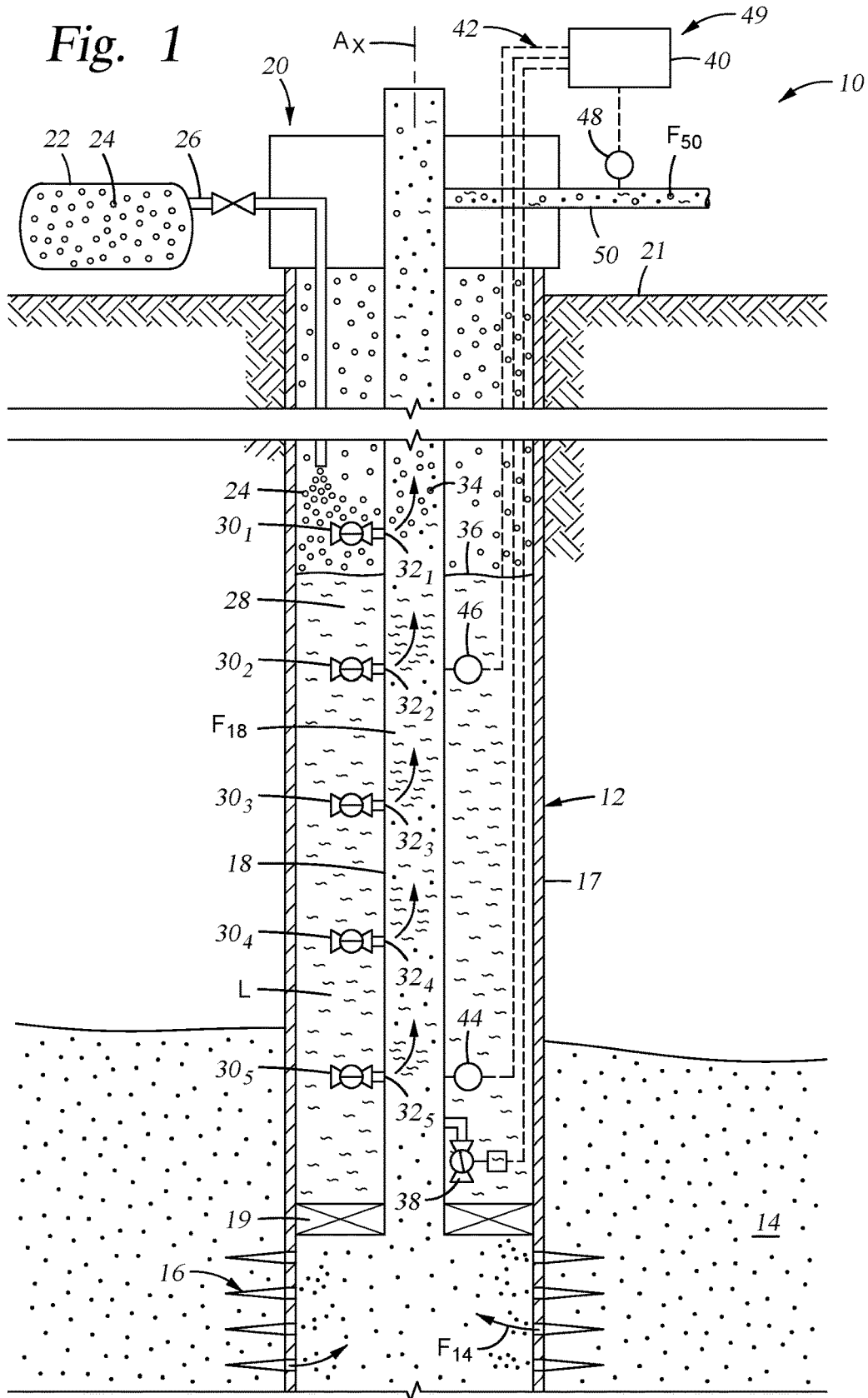

Fig. 2

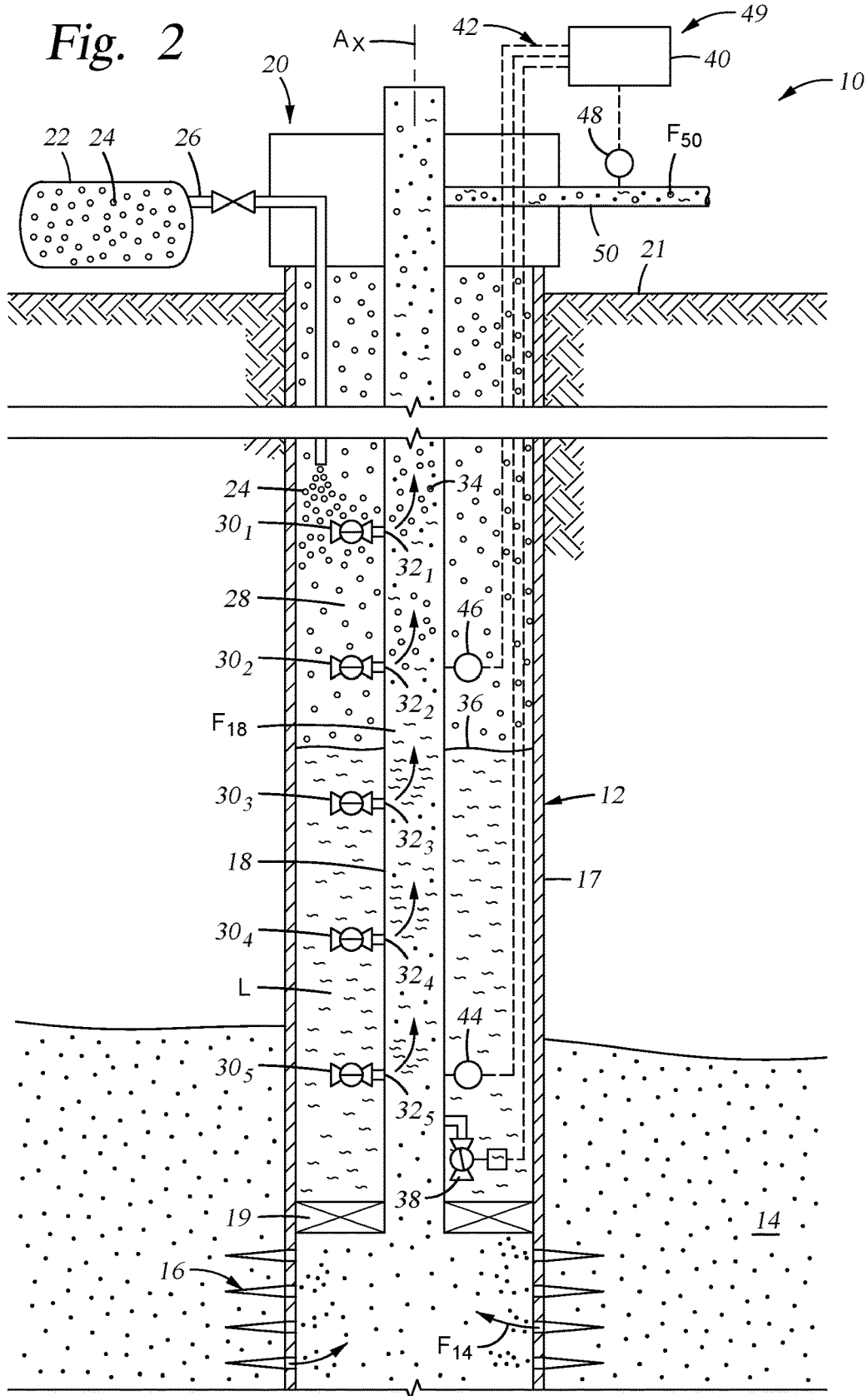
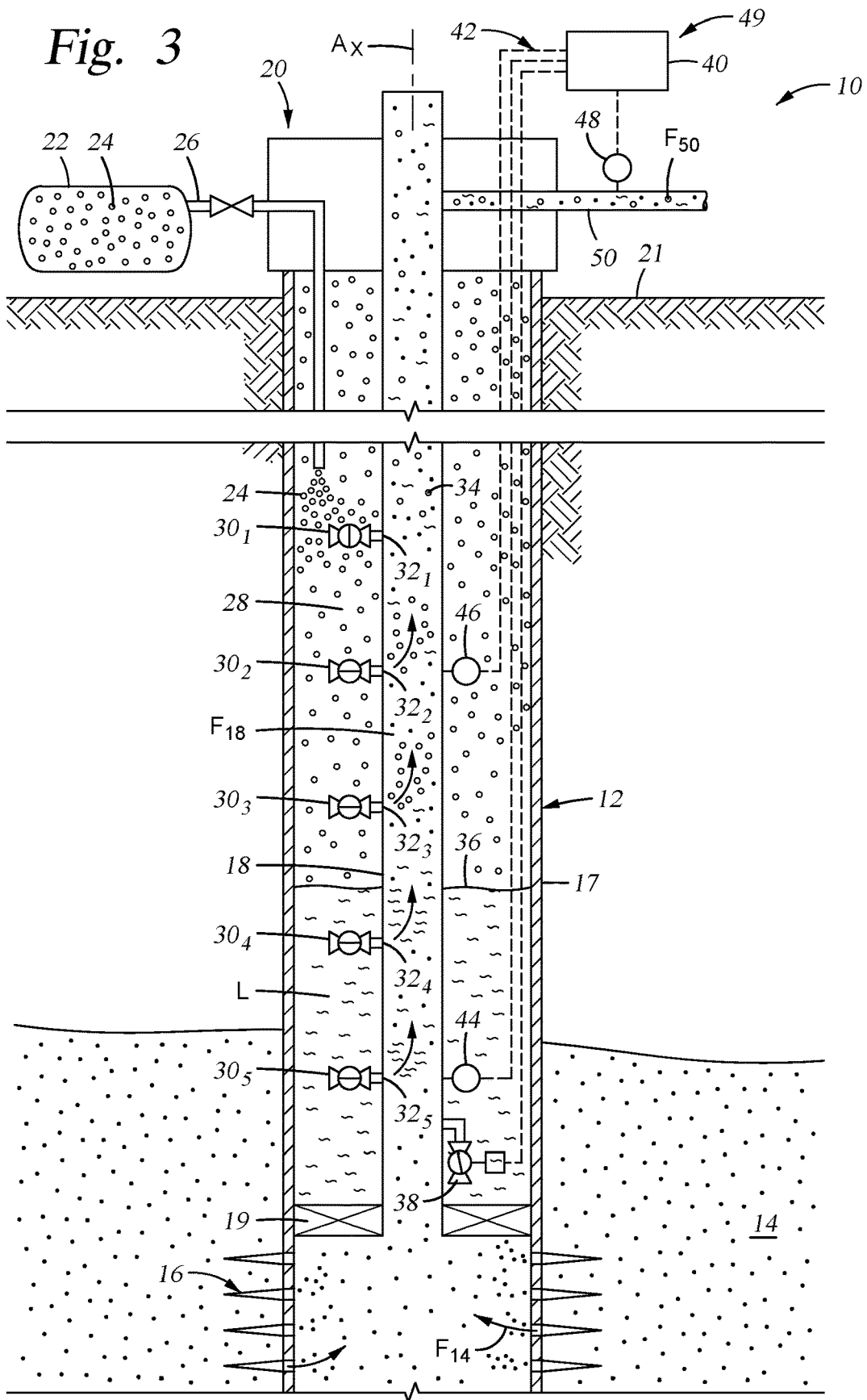
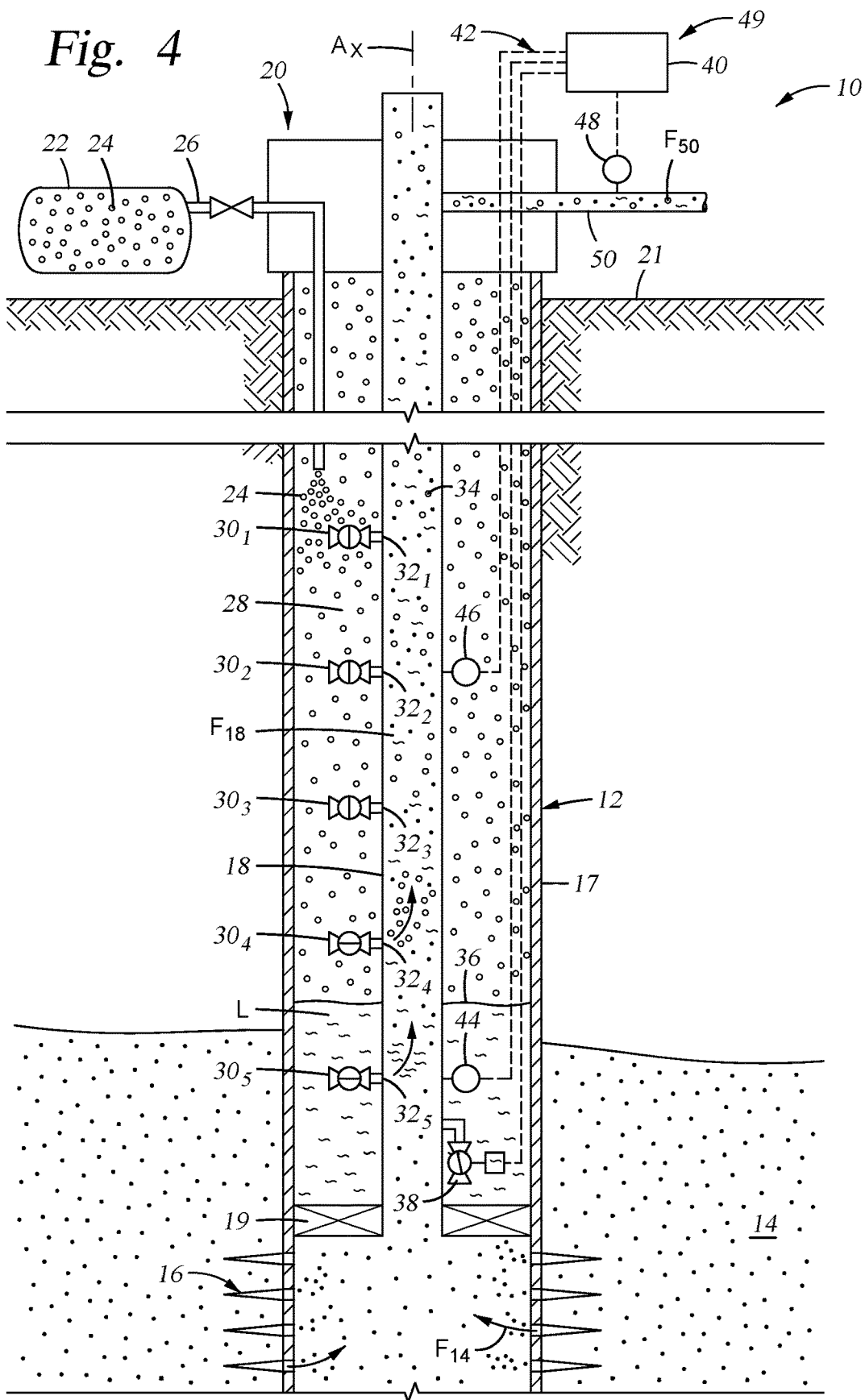

Fig. 3



L



L

Fig. 5

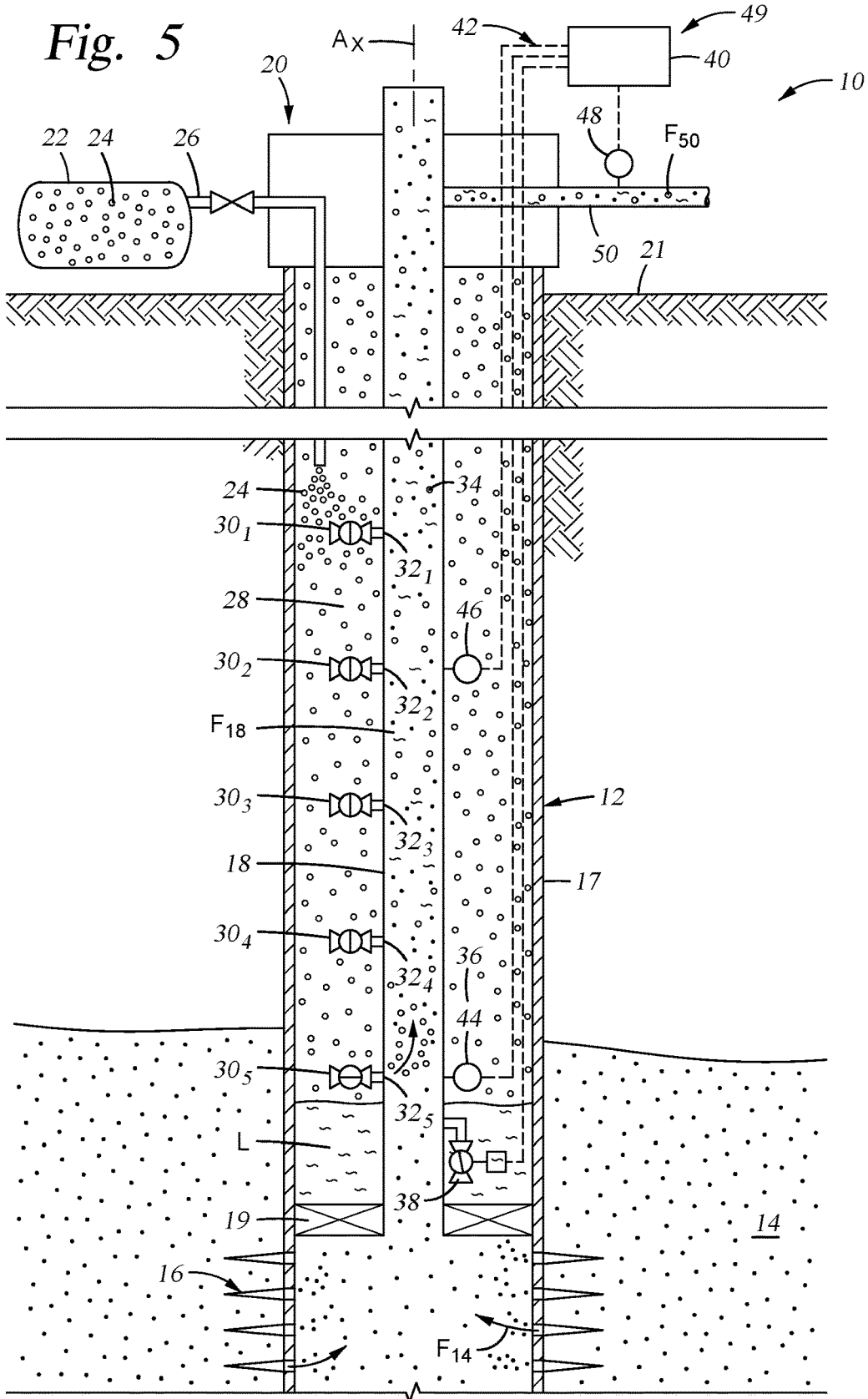

L

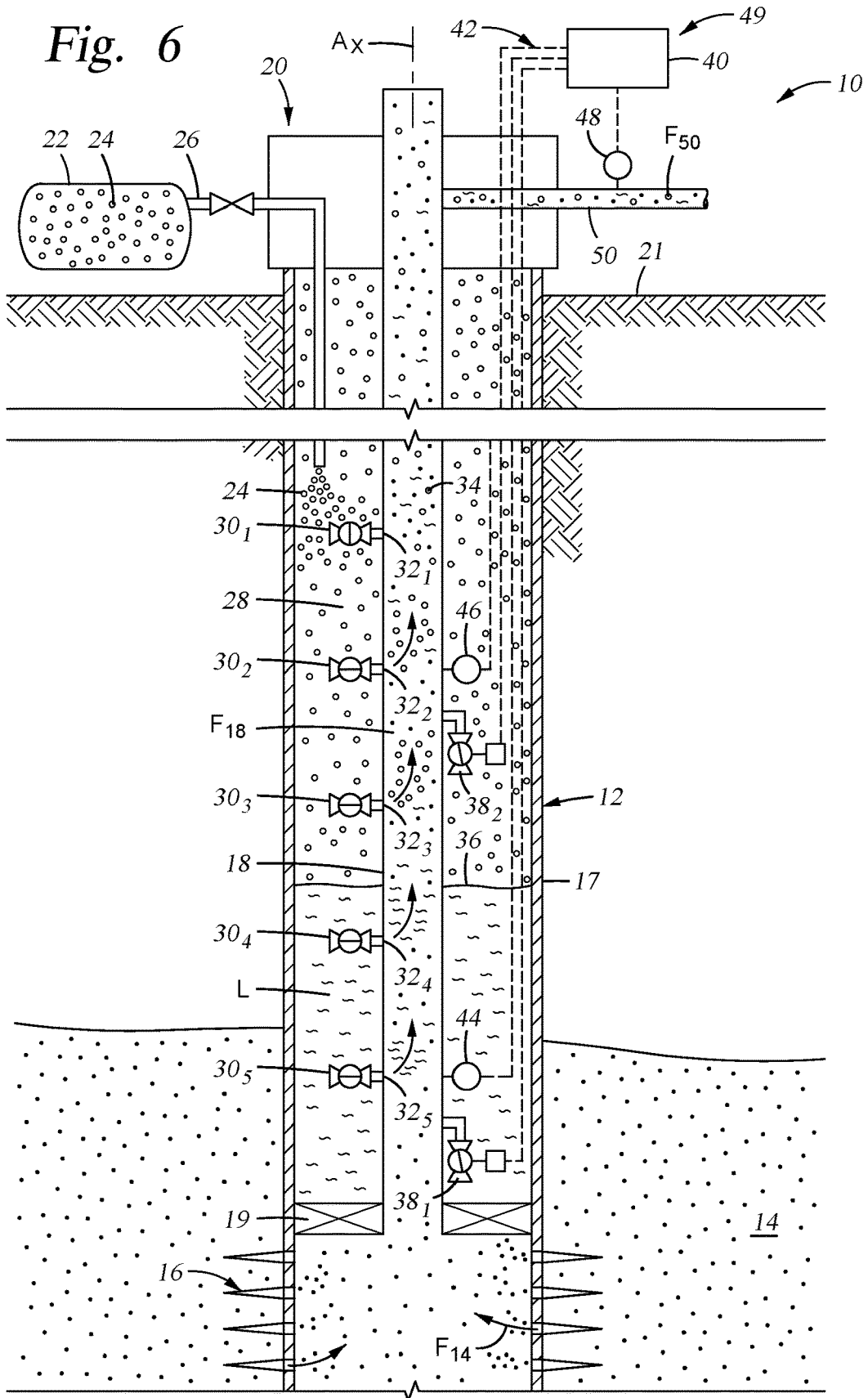

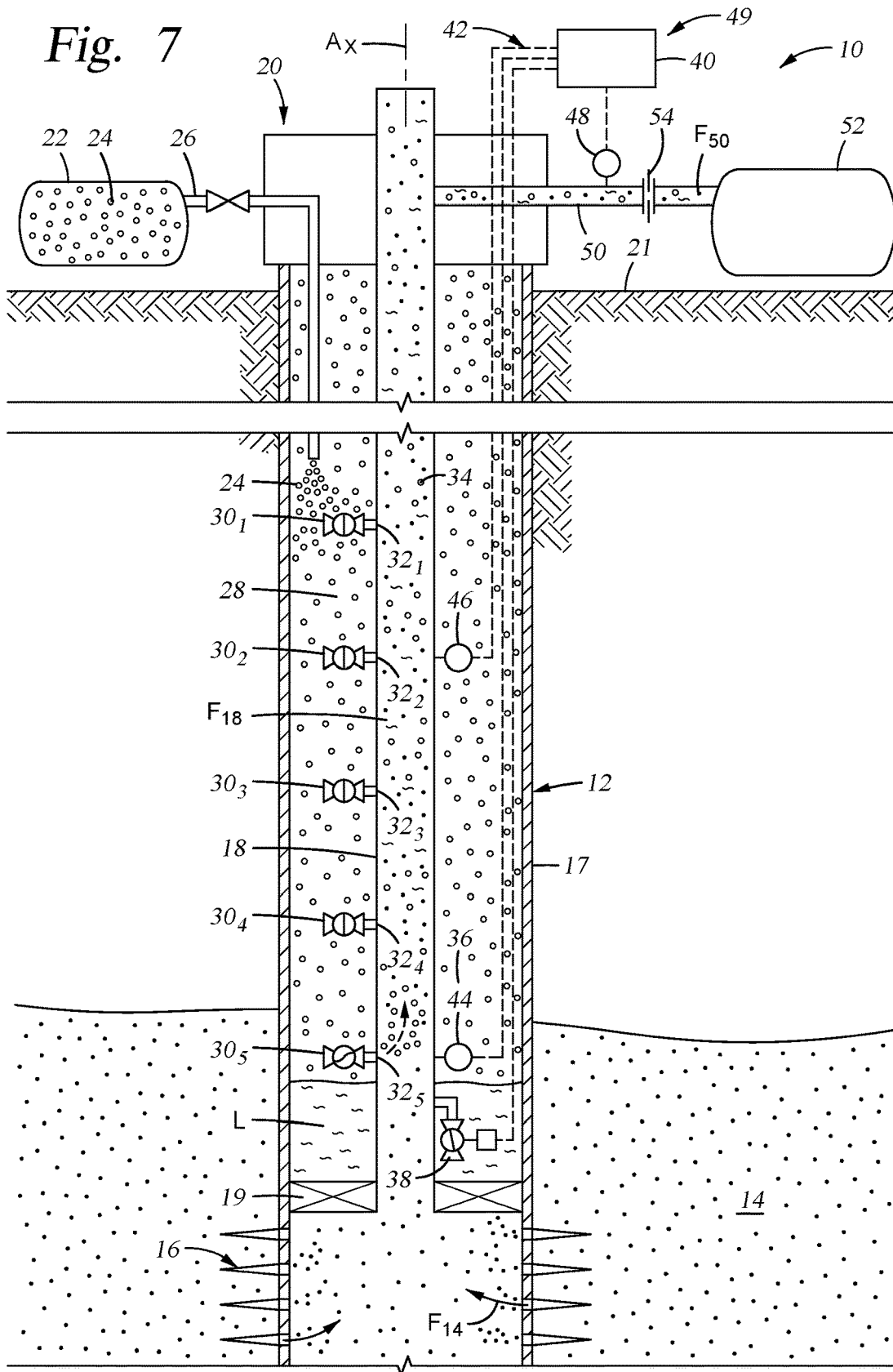

HYBRID GAS LIFT SYSTEM

CROSS-REFERENCE TO RELATED APPLICATION

[0001] This application claims priority to and the benefit of co-pending U.S. Provisional Application Ser. No. 62/972,421, filed Feb. 10, 2020, the full disclosure of which is incorporated by reference herein in its entirety and for all purposes.

BACKGROUND OF THE INVENTION

1. Field of Invention

[0002] The present disclosure relates to using lift gas to increase fluid production from a well.

2. Description of Prior Art

[0003] Lift systems for unloading liquids from a well include pumps, such as electrical submersible pumps (“ESP”), which pressurize the liquid downhole and propel it up production tubing that carries the pressurized fluid to surface. Sucker rods and plunger lift pumps are also sometimes employed for lifting liquid from a well. In wells having an appreciable amount of gas mixed with the liquid a two-phase fluid may form and gas is sometimes separated from the fluid upstream of the ESP and routed to surface separately from the pressurized liquid. In some instances compressor pumps are employed to pressurize the two-phase fluid to lift it to surface. A gas lift system is another type of artificial lift system, and that injects a lift gas, typically from surface, into production tubing installed in the well. The lift gas is usually directed into an annulus between the production tubing and sidewalls of the well, and from the annulus into the production tubing. Gas lift is commonly employed when pressure in a formation surrounding the well is insufficient to urge fluids to surface that are inside of the production tubing. By injecting a sufficient amount of lift gas into the production tubing, static head pressure of fluid inside the production tubing is reduced to below the pressure in the formation, so that the formation pressure is sufficient to push the fluids inside the production tubing to surface. Fluids that are usually in the production tubing are hydrocarbon liquids and gases produced from the surrounding formation. Sometimes these fluids are a result of forming the well or a workover, and have been directed into the production tubing from the annulus.

[0004] The lift gas and fluid in the annulus is typically injected into the production tubing through valves that are in communication with ports intersecting sidewalls of the production tubing. An injection pressure operated (“IPO”) gas lift valve is one type of valve for injecting lift gas into production tubing, and are typically disposed at various depths along the production string. IPO valves are usually designed to close in response to pressure in the annulus, and with staggered closing pressures so the lowermost valve is set to close at the lowest annulus pressure. Production pressure operated (“PPO”) gas lift valves are another type of valve used for gas lift injection. PPO valves are also mounted at different locations along the production string and have staggered set pressures; but operate in response to pressure inside the production tubing rather than in the annulus, and with the lowermost valve closing at the highest set pressure. Generally both IPO and PPO valves include a

spring or are nitrogen charged and that automatically open or close at designated set pressures. Another type of valve is one that is surface controlled and whose operation is not dependent on annulus or tubing pressure, generally the number of surface controlled valves is lower than the number of IPO or PPO valves, and can be as few as a single valve; however the surface controlled valves tend to be expensive as compared to the IPO or PPO valves. Disadvantages of IPO valves is that annulus pressure can sometimes exceed the set pressure, which can limit the depth of the gas injection and reduce production. Disadvantages of the PPO valves is that some operational problems are generally not detectable, such as if some of the PPO valves begin to multi-point or chatter, in both conditions production capacity of the well is reduced as well as system reliability. PPO valves primarily respond to pressure in the tubing, but can be slightly affected by pressure in the annulus; similarly IPO valves primarily respond to pressure in the annulus, but can be slightly affected by pressure in the tubing.

SUMMARY OF THE INVENTION

[0005] Disclosed herein is an example method of lifting liquid from a well that includes injecting lift gas into production tubing through production pressure operated (“PPO”) valves that are in selective communication with a string of production tubing in the well, monitoring conditions in the production tubing, identifying a condition in the production tubing indicating one or more of the PPO valves is experiencing an anomaly, and correcting the anomaly by altering a characteristic of fluid in the production tubing. Alternatively, the step of correcting the anomaly involves directing a signal from surface to a surface controlled valve to adjust the amount of lift gas being injected into the production tubing. In one example, pressure in the production tubing is monitored to identify a condition in the production tubing indicating one or more of the PPO valves is experiencing an anomaly. In an embodiment, the anomaly being corrected is adjusting a rate of lift gas injection into the production tubing through a surface controlled valve or adjusting pressure of fluid flowing from the production tubing. Lift gas is optionally added into the production tubing through a surface controlled valve. The method optionally includes unloading liquid from an annulus surrounding the production tubing by pressurizing the annulus with lift gas, wherein the liquid is produced from a formation and that is directed into an end of the production tubing. In one alternative, the liquid is directed into the production tubing through the PPO valves.

[0006] Another example of method of well operations is disclosed and that includes providing lift gas into a well that is equipped with production tubing, production pressure operated (“PPO”) valves on the production tubing, casing that lines the well, and an annulus defined between the producing tubing and the well, the PPO valves are selectively changed between an open configuration to define a path for a portion of the flow of the lift gas to enter into the production string from the annulus, and a closed configuration to block the flow of the lift gas to enter into the production string from the annulus, directing the lift gas into the annulus, maintaining a flow of the lift gas at a substantially constant rate into the annulus, and determining an anomalous operation of the PPO valves by monitoring conditions in the production tubing and correcting the anomalous operation of the PPO valves by adding lift gas

into the production tubing through a valve that is controlled from surface. In an alternative, the method further includes maintaining a pressure of the lift gas at which one of the PPO valves is designed to be in an open configuration and that PPO valves at a lesser depth are designed to be in a closed configuration. In an alternate embodiment, the condition is pressure. The anomalous operation is optionally corrected by adjusting pressure in the production tubing or alternatively by adjusting an amount of lift gas being injected into the production tubing by a surface controlled valve.

[0007] An example system for use in well operations includes a source of lift gas having a line in communication with an annulus in the well that is defined between production tubing and casing that lines the well, production pressure operated (“PPO”) valves provided at different depths along the production tubing that are selectively changed between an open configuration that forms a path through a sidewall of the production tubing and provides communication between the annulus and inside of the production tubing, and a closed configuration that forms a barrier in the path, a surface actuated valve that is changeable between an open configuration that forms a path through a sidewall of the production tubing and provides communication between the annulus and inside of the production tubing, and a closed configuration that forms a barrier in the path; and a controller that identifies an anomalous operation of the PPO valves, and corrects the anomalous operation of the PPO valves by selectively configuring the surface actuated valve into the open configuration. In an alternative, pressure in the production string is monitored by the controller. Pressure in a flow production line on surface is optionally monitored by the controller, and the controller identifies the anomalous operation of the PPO valves based on the monitored pressures. In one example, the surface controlled valve is at a greater depth than the PPO valves. Embodiments of the system also include pressure sensors and control lines, and where the controller, pressure sensors, and control lines define a communication circuit.

BRIEF DESCRIPTION OF DRAWINGS

[0008] Some of the features and benefits of the present invention having been stated, others will become apparent as the description proceeds when taken in conjunction with the accompanying drawings, in which:

[0009] FIGS. 1-5 are schematic side sectional views of unloading a well using a lift gas injection system equipped with PPO valves and a system controlled valve.

[0010] FIG. 6 is a schematic side sectional view of an example of the lift gas injection system of FIG. 1, and with PPO valves experiencing multi-pointing.

[0011] FIG. 7 is a schematic side sectional view of an example of the lift gas injection system of FIG. 1, and with a PPO valves experiencing chattering.

[0012] While the invention will be described in connection with the preferred embodiments, it will be understood that it is not intended to limit the invention to that embodiment. On the contrary, it is intended to cover all alternatives, modifications, and equivalents, as may be included within the spirit and scope of the invention as defined by the appended claims.

DETAILED DESCRIPTION OF INVENTION

[0013] The method and system of the present disclosure will now be described more fully hereinafter with reference

to the accompanying drawings in which embodiments are shown. The method and system of the present disclosure may be in many different forms and should not be construed as limited to the illustrated embodiments set forth herein; rather, these embodiments are provided so that this disclosure will be thorough and complete, and will fully convey its scope to those skilled in the art. Like numbers refer to like elements throughout. In an embodiment, usage of the term “about” includes +/-5% of a cited magnitude. In an embodiment, the term “substantially” includes +/-5% of a cited magnitude, comparison, or description. In an embodiment, usage of the term “generally” includes +/-10% of a cited magnitude.

[0014] It is to be further understood that the scope of the present disclosure is not limited to the exact details of construction, operation, exact materials, or embodiments shown and described, as modifications and equivalents will be apparent to one skilled in the art. In the drawings and specification, there have been disclosed illustrative embodiments and, although specific terms are employed, they are used in a generic and descriptive sense only and not for the purpose of limitation.

[0015] Shown in a side partial sectional view in FIGS. 1 through 5 is an example of a gas lift system 10 being used for unloading of a liquid L from a well 12. Well 12 is shown intersecting a subterranean formation 14 and having perforations 16 that extend radially outward from the well 12 into the formation 14. Perforations 16 also intersect casing 17 that lines the well 12. Production tubing 18 is inserted within the casing 17. Fluid F_{14} is from formation 14 and shown exiting perforation 16 and is directed into the production tubing 18 by packers 19 that span between the tubing 18 and casing 17. Production tubing 18 is mounted on its upper end within a wellhead assembly 20 shown on surface 21. Included with gas lift system 10 is a lift gas source 22 shown containing an amount of lift gas 24. Examples of a lift gas source 22 include adjacent wells, a gas line manifold, in-situ gas from well 12, compressors, and other known or future developed sources of gas for use in a lift gas application. A line 26 attaches to a discharge of the lift gas source 22 and provides a conduit for transporting the lift gas 24 into an annulus 28 that is defined in a space between the production tubing 18 and casing 17. Alternatives of liquid L include fluids in the well 12 after commissioning, such as drilling fluids, and also include fluids in well 12 when no longer producing or when shut in.

[0016] Also included with the gas lift system 10 are a series of production pressure operated (“PPO”) valves 30₁₋₅ that are shown mounted to an exterior of the production tubing 18 at different depths within the well 12. In alternatives, PPO valves 30₁₋₅ are inside production tubing 18. PPO valves 30₁₋₅ attach respectively to outlet ports 32₁₋₅ that extend through the sidewall of the production tubing 18. The PPO valves 30₁₋₅ of FIG. 1 are shown in an open configuration that provides a path through the PPO valves 30₁₋₅ for the communication of fluid and/or pressure. When PPO valves 30₁₋₅ are in the open configuration, annulus 28 and outlet ports 32₁₋₅ are in communication through the PPO valves 30₁₋₅ which provides for communication between annulus 28 and the inside of production tubing 18. The PPO valves 30₁₋₅ of FIG. 1 are selectively also configured into a closed configuration that blocks communication between the annulus 28 and outlet ports 32₁₋₅, which in turn blocks communication between annulus 28 and inside of tubing 18.

In the illustrated example, the PPO valves 30_{1-5} are automatically changeable between the open and closed configurations in response to pressure within the production tubing **18**.

[0017] The example of FIG. 1 illustrates an example of unloading a liquid L shown in annulus **28** and at a depth that is between PPO valve 30_1 and PPO valve 30_2 . A portion of annulus **28** above the level of liquid L is occupied by lift gas **22**, where lift gas **22** contacts an upper level of liquid L defines an interface **36** shown in annulus **28** between valve 30_1 and valve 30_2 . Interface **36** is generally perpendicular to an axis A_X of well. In an example step of unloading the liquid L, which begins prior to that as illustrated in FIG. 1, the introduction of the lift gas **24** increases pressure in the annulus **28** to above that of within the production tubing **18** and forces liquid L downward in the annulus **28**, through the open PPO valves 30_{1-5} (and through the outlet ports 32_{1-5}), and into the production tubing **18**. As the volume of liquid L in annulus **28** is reduced, interface **36** drops below PPO valve 30_1 . At this stage, liquid L continues to flow through PPO valves 30_{2-5} but it is injection gas **24** that flows through PPO valve 30_1 , the outlet port 32_1 , and into the production tubing **18**. Injection gas **24** inside of the production tubing **18** form gas bubbles **34** shown rising within the fluid F_{18} that is flowing within the production tubing **18** within well **12** and upwards to the wellhead assembly **20**. In an example fluid F_{14} represents fluid produced from the formation **14**, examples of which include one or more of hydrocarbon liquid, hydrocarbon gas, water, and combinations; and fluid F_{18} includes a mixture of fluid F_{14} and lift gas **24**. Introducing lift gas **24** to the fluid F_{18} reduces the density of fluid F_{18} and in turn promotes flow of fluid F_{18} upwards within production tubing **18**. Continued addition of the lift gas **24** into annulus **28** continues to urge the liquid L through the PPO valves 30_{2-5} ; as shown in FIG. 5 addition of the lift gas **24** eventually removes the liquid L from the portion of the annulus **28** above the lowermost PPO valve 30_5 . It should be pointed out that the number of PPO valves for use with the gas lift system **10** is not limited to the number shown in the figures.

[0018] Referring back to FIG. 2 shown is that the continued introduction of the lift gas **24** into annulus **28** has urged the liquid L within annulus **28** to below the depth of the PPO valve 30_2 . In this example, PPO lift valves 30_1 and 30_2 are both shown in an open configuration and providing a flow of lift gas **24** into the production tubing **18** and producing lift gas bubbles **34**. In an embodiment, the PPO lift valves 30_{1-5} have set pressures and are designed to automatically close upon pressure inside the production string **18** reaching a designated value. Additionally, the pressures are staggered so that adjacent valves close at different pressures and generally the greater the depth of the PPO valve 30_{1-5} the greater will be its closing pressure. In the example of FIGS. 1 through 5, PPO valve 30_1 will automatically close at a pressure less than each of PPO valves 30_{2-5} . Similarly, PPO valve 30_2 will close at a lower pressure than any of 30_{3-5} and so on. In one alternative, an upper one of the PPO valves will remain in an opened configuration for a period of time after which the interface **36** drops below an adjacently lower PPO valve, so that for a period of time two adjacent PPO valves will be in an open configuration and while lift gas **24** is flowing through each of them; but in this example the upper PPO valve is designed to close before the interface **36** reaches the adjacent lower PPO valve so that lift gas **24**

flows through no more than two PPO valves at the same time. In a further alternative of this example, the upper one of the adjacent PPO valves will automatically configure to its closed configuration, such as shown in FIG. 4 where interface **36** is between PPO valves 30_4 and 30_5 and PPO valves 30_{1-3} have automatically reconfigured into the closed configuration. As illustrated in FIG. 5, which is a final step of the example of unloading the liquid L from the annulus **28**, the lowermost PPO valve 30_5 remains in the opened configuration and provides for a flow of lift gas **24** into the production tubing **18**.

[0019] Referring back to FIG. 1, a surface controlled valve **38** is included with the example of the gas lift system **10** and shown coupled with production tubing **18**. Combining the surface controlled valve **38** with the PPO valves 30_{1-5} results in a gas lift system **10** sometimes referred to as a hybrid system. A hybrid system with PPO valves is able to inject lift gas **24** at greater depth than one with IPO valves (due to the closing pressure sequence), which provides an advantage of increased production of hydrocarbons from a well. An outlet port **39**, similar to ports 32_{1-5} , intersects production tubing **18** adjacent to where surface controlled valve **38** couples with production tubing **18**. Surface controlled valve **38** is selectively put into an open configuration to create a communication path through valve **38**, which provides flow and pressure communication between annulus **28** and port **39** through valve **38**; that in turn provides communication between annulus **28** and the inside of production tubing **18**. Surface controlled valve **38** is also selectively put into a closed configuration that blocks the flow path through the valve **38**, and isolates port **39** from annulus **28**. An example of a surface controlled valve **38** is described in Wygnanski, U.S. Pat. No. 8,925,638, and which is incorporated by reference herein its entirety and for all purposes. A controller **40** is shown located outside of wellbore **12**, and that is in selective signal communication with surface controlled valve **38** via a communication circuit **42**. Examples of communication circuits include means for transmission of communication; such as but not limited to wireless, fiber optics, hard-wired, and combinations. In an alternate example controller **40** is included within wellbore **12**. Pressure sensors **44**, **46**, **48** are shown also in communication with the controller **40** via communication circuit **42**. The combination of the controller **40**, circuit **42**, and sensors **44**, **46**, **48** define an intelligent well system **49**. In the example, sensor **44** is depicted on a pressure tap adjacent the surface controlled valve **38**, and alternatives exist in which pressure sensor **44** is integrated within or substantially next to surface controlled valve **38** and registers pressure within the production tubing **18** at or substantially adjacent where the surface controlled valve **38** attaches to outlet port **39** and provides communication between annulus **28** and inside of production tubing **18**. In examples, operation of surface controlled valve **38** is managed by controller **40** and through the communication circuit **42**. Alternatively, commands for operating the surface controlled valve **38** are delivered from above surface **21** and via communication circuit **42** but from a source other than controller **40**. Illustrated in FIGS. 3 through 7 is that the fluid F_{18} flowing upward within the production tubing **18** is diverted into a production line **50**, within production line **50** fluid F_{50} flows to a location remote from the well **12**. In alternatives, a choke valve (not shown) is included in line **50**, and optional locations of sensor **48** include upstream and downstream of choke valve, or pres-

sure upstream and downstream of choke valve is measured by a combination of another sensor (not shown) and sensor 48.

[0020] Shown in FIG. 6 as an example of a wellbore operation 10 and during which more PPO valves are undergoing an anomalous condition known as multi-pointing. Multi-pointing is a scenario in which more than two of the PPO valves above interface 36 are in the open configuration at the same time, and lift gas 24 is flowing into the production tubing 18 through these open PPO valves. Multi-pointing is an undesirable situation as the introduction of the lift gas 24 into production tubing 18 actually hinders a flow of fluid F_{18} that is below the interface 36 from flowing upward to the wellhead assembly 20; a condition that is sometimes referred to as a choked flow. Not to be bound by theory, but choked flow occurs because a sufficient amount of the column of fluid F_{18} in production tubing 18 remains substantially in liquid form and generates a static head at or below packers 19 which exceeds a pressure from within formation 14, so that fluid F_{14} is unable to enter the production string 18. During an example of multi-pointing, lift gas 24 is being injected from more than one of the PPO valves 30₁₋₅ (which are each sometimes referred to as a valve station) because of an operational excursion in the production tubing 18 causing an unplanned or un-designed opening of one or of the PPO valves 30₁₋₅. Consequently all of the gas is not going through the lowest valve, and that reduces drawdown and therefore production. As far as production goes, choked flow refers to a situation where too much lift gas is being produced at the surface. In one example of an anomalous operation, an amount of lift gas flowing in the production tubing 18 exceeds a design flow-rate of the wellhead assembly 20, production line 50, or a production manifold (not shown) and impedes a flow of fluid F_{18} inside of or exiting the production tubing 18; impeding the flow of fluid F_{18} in turn increases pressure of fluid F_{18} at wellhead assembly 20, and/or the pressure of fluid F_{50} inside production line 50. This can lead to reduced production because there is subsequently reduced drawdown downhole at the formation 14. It can also lead to multi-pointing because the pressure in the production tubing 18 increases. It can also cause unstable pressures in the production tubing 18 which can lead to chatter (i.e. repeated open and closed cycling of a valve at a frequency greater than design frequency and that can lead to valve damage).

[0021] In a non-limiting example of operation, controller 40 of system 49 is configured to recognize multi-pointing, such as by analysis of readings obtained by the sensors 44, 46, 48 and in turn provides instructions to operate surface controlled valve 38 and inject an amount of lift gas 22 into production tubing 18. In the example of FIG. 6, an additional surface controlled valve 382 is illustrated at a depth uphole of surface controlled valve 38₁. There are a number of ways to determine multi-pointing. In one example, multi-pointing is determined by a reduced injection rate at a surface controlled unit 38 downhole while there is the same rate of injection uphole (i.e. a flowrate of lift gas 24 being injected into the annulus 28 through line 26); indicating an increased amount of lift gas 24 flowing through the PPO valves 30₁₋₅. In an alternative to this example, the injection rate downhole is determined by a known orifice size in the surface controlled valve 38 and a pressure differential across the orifice. Another option is to periodically and temporarily vary the orifice size (cross-sectional area) in the surface

controlled valve 38 and monitor pressure at locations in the production tubing 18 to develop a pressure profile; based on the pressure profile it is determined if lift gas 24 is being injected in more than one of the PPO valves 30₁₋₅. Correcting a multi-pointing situation depends on the particular scenario or operational anomaly. In an example, pressure in the production tubing 18 is at or above a value that creates multi-pointing or another anomalous situation, and that is identified by monitoring pressure downhole such as described above; an example of a corrective action is to open a choke (not shown) on surface 21 to reduce pressure in the production tubing 18 to a level so that the pressure in the production tubing 18 is correspondingly reduced and the PPO valves 30₁₋₅ that are in the multi-pointing condition close. In another alternative of a corrective action the downhole surface controlled valve 38 is shifted to a smaller orifice size to reduce lift gas 24 flow through the valve 38 to reduce the production manifold pressure by reducing the gas flow inside the production tubing 18 and through the wellhead assembly 20. Other similar options are available depending on the particular set of circumstances. An advantage of the method and system described herein is the ability to detect that an operational anomaly is occurring, either through monitoring pressure downhole or surface controlled variation of lift gas flow into the production tubing 18; a further advantage is the ability to take action to correct the anomaly, where the action is through sending control signals (either automatically from the controller 40, or manually from an operator on surface 21) which does not require intervention to correct the situation.

[0022] Shown in FIG. 7 is an example of operation of gas lift system 10 and in which PPO valves 30₁₋₄ are each in a closed configuration and not providing communication between the annulus 28 and inside of production tubing 18. Also in the example of FIG. 7, PPO valve 30₅ is in the open configuration and shown directing lift gas 24 into the production tubing 18 that forms gas bubbles 34. Further illustrated in FIG. 7 is that fluid F_{50} is flowing in the production line 50, and that production line 50 extends to a terminal 52 where the fluid F_{50} is delivered. Schematically illustrated within production line 50 is a restriction 54 that produces occasional pressure spikes that are transferred from within line 50 and back into fluid F_{18} within production tubing 18, as shown the pressure spikes causes PPO valve 30₅ to move into a closed configuration temporarily. This condition eventually cycles and causes rapid opening and closing of PPO valves 30₅ to induce a situation known as chattering. Chattering is an undesirable situation as it can cause damage to the valve 30₅, and by reducing the introduction of lift gas 24 also limits production of fluid F_{14} . In the example of FIG. 7 the sensors 44, 46, 48 deliver pressure information to controller 40 so that controller recognizes the chattering condition of PPO valve 30₅, which is another known anomaly of PPO valves, and initiates corrective action by opening surface controlled valve 38 via its communication through the communication circuit 42. There are numerous situations that can cause chatter, in an example valve chatter is caused by unstable flow in which there is a pressure imbalance and that causes fluctuations in tubing pressure. As mentioned above, in some examples a choking anomaly at the surface causes an upper PPO valve to open. This in turn causes lift gas 24 to bypass the lower PPO valves and inject into the production tubing 18 closer to the surface, leading to reduced drawdown and reduced produc-

tion. In some instances this eventually causes the production from the formation **14** to drop and reduces pressure in the production tubing **18**. Then gas lift injection reinitiates sequentially downhole through the PPO valves **30₁₋₅** back down and the process happens again. Further in this example, monitoring conditions in the well **12**, such as temperature, pressure, and flowrates provides information indicating a situation in which one or more of PPO valves **30₁₋₅** are in a state of chattering, are likely chattering, or tending to a chattering state. As noted above, the step of monitoring includes gathering information from one or more of surface controlled valve **38**, sensors **44**, **46**, **48**, and controller **42**. In addition to identifying when or if valve chatter is occurring, the monitoring described herein also provides indications if multi-pointing is occurring or tending to a situation in which multi-point would or could occur. In some instances multi-pointing and chattering have similar causes. In alternate examples of operation, the complex and varying properties of the fluid $F_{1,8}$ result in multi-pointing, and change to unsteady chatter with a change in pressure as low as a few pounds per square inch.

[0023] Advantages of the intelligent well system **49** is that injection depth is inferred from the sensors **44**, **46**, **48** and controller **40**. Alternatively, the sensors **44**, **46**, **48** include means for monitoring temperature. Examples exist in which additional sensors are located along the production tubing **18** and also in production line **50**. In an alternative pressure readings from the sensors **44**, **46**, **48** (and possibly others) are used in the calculation of a pressure gradient for the tubing **18** and annulus **28**. In an example of operation of this embodiment, during unloading a liquid level in the annulus **28** is inferred based a measured pressure gradient in the annulus **28** to indicate the depth of interface **36**. Alternatively, during production the pressure gradient of the production string **18** is used. Further in this example injection from a specific surface controlled valves **38_{1-n}** is identified based on a step change in pressure gradient. During unload and prior to the gas injection reaching an uppermost or lowest depth surface, controlled step changes in bottom hole flowing pressure is an indicator that gas injection has reached a new injection point (examples of injection points include depths of PPO valves **30₁₋₅**, surface controlled valves **38_{1-n}**, and combinations. In an alternative, at any point production models are used to compare the pressure gradients to theoretical to expose any anomalous behavior. Examples exist where changes in the temperature gradient indicate gas injection at a specific surface controlled unit **38_{1-n}**. It is pointed out that use of the gas lift system **10** with the PPO valves is not limited to unloading, but includes use for the production of hydrocarbon fluids from within a well.

[0024] In an embodiment of a hybrid system that includes a surface controlled system and PPO valves, full gas injection pressure is applied at the gas injection point; advantages of which include an improved drawdown. Optionally in this embodiment, the hybrid system remains in a stable operating mode at injection pressures at the surface that exceed injection pressures at which other systems having IPO valves would not be stable, and experience multi-pointing. Advantages of operating at higher pressures include increased drawdown and elimination of a need for a well workover to utilize additional injection pressure if it becomes available. Another advantage provided by the hybrid system is the ability to detect and correct an anomaly caused by the lift gas **24** having slugs of liquid (such as water

or condensate) which accumulate in the annulus **28**, and from the annulus **28** make their way into the production tubing **18** through surface operated valve **38** or one or more of the PPO valves **30₁₋₅**. In some operational scenarios, these slugs of liquid cause chatter and/or multi-pointing in one or more of valves **30₁₋₅**, which can be detected with the present system, and corrected with the injection of lift gas **24** through surface operated valve **38**.

[0025] In a non-limiting example of operation, data is interpreted to determine when the well has been unloaded to the surface controlled section, and then designated surface controlled units are actuated to direct flow into selected areas. More specifically, in this example information from surface controlled valve **38** or one or more of sensors **44**, **46**, **48** to determine when lift gas **24** or interface **36** reaches the surface controlled valve **38**. In an alternative, this information is obtained with information from a single one of sensors **44**, **46**, **48** in conjunction with a known surface pressure or watching the rate of change of the downhole pressure.

[0026] The present invention described herein, therefore, is well adapted to carry out the objects and attain the ends and advantages mentioned, as well as others inherent therein. While a presently preferred embodiment of the invention has been given for purposes of disclosure, numerous changes exist in the details of procedures for accomplishing the desired results. These and other similar modifications will readily suggest themselves to those skilled in the art, and are intended to be encompassed within the spirit of the present invention disclosed herein and the scope of the appended claims.

What is claimed is:

1. A method of lifting liquid from a well comprising:
 - injecting lift gas into production tubing through pressure production operated (“PPO”) valves that are in selective communication with a string of production tubing in the well;
 - monitoring conditions in the production tubing;
 - identifying a condition in the production tubing indicating one or more of the PPO valves is experiencing an anomaly; and
 - correcting the anomaly by altering a characteristic of fluid in the production tubing.
2. The method of claim 1 wherein the step of correcting the anomaly comprises directing a signal from surface to a surface controlled valve to adjust the amount of lift gas being injected into the production tubing.
3. The method of claim 1 wherein the step of identifying a condition in the production tubing indicating one or more of the PPO valves is experiencing an anomaly comprises monitoring pressure in the production tubing.
4. The method of claim 1 wherein correcting the anomaly comprises an action selected from the group consisting of adjusting a rate of lift gas injection into the production tubing through a surface controlled valve and adjusting pressure of fluid flowing from the production tubing.
5. The method of claim 1 further comprising adding lift gas into the production tubing through a surface controlled valve.
6. The method of claim 1, wherein the liquid comprises liquid produced from a formation and that is directed into an end of the production tubing.
7. The method of claim 1, wherein the liquid is directed into the production tubing through the PPO valves.

8. A method of well operations comprising:
providing lift gas into a well comprising production tubing, pressure production operated (“PPO”) valves on the production tubing, casing that lines the well, and an annulus defined between the producing tubing and the well, the PPO valves are selectively changed between an open configuration to define a path for a portion of the flow of the lift gas to enter into the production string from the annulus, and a closed configuration to block the flow of the lift gas to enter into the production string from the annulus;
directing the lift gas into the annulus;
maintaining a flow of the lift gas at a substantially constant rate into the annulus;
determining an anomalous operation of the PPO valves by monitoring conditions in the well; and
correcting the anomalous operation of the PPO valves by adding lift gas into the production tubing through a valve that is controlled from surface.

9. The method of claim **8** further comprising maintaining a pressure of the lift gas at which one of the PPO valves in designed to be in an open configuration and that PPO valves at a lesser depth are designed to be in a closed configuration.

10. The method of claim **8** wherein the condition comprises pressure.

11. The method of claim **10** wherein the anomalous operation is corrected by adjusting pressure in the production tubing.

12. The method of claim **10** wherein the anomalous operation is corrected by adjusting an amount of lift gas being injected into the production tubing by a surface controlled valve.

13. The method of claim **10**, wherein the pressure is monitored in one or more of the production tubing, and in an annulus around the production tubing.

14. A system for use in well operations comprising:
a source of lift gas having a line in communication with an annulus in the well that is defined between production tubing and casing that lines the well;
production pressure operated (“PPO”) valves provided at different depths along the production tubing that are selectively changed between an open configuration that forms a path through a sidewall of the production tubing and provides communication between the annulus and inside of the production tubing, and a closed configuration that forms a barrier in the path;
a surface actuated valve that is changeable between an open configuration that forms a path through a sidewall of the production tubing and provides communication between the annulus and inside of the production tubing, and a closed configuration that forms a barrier in the path; and
a controller that identifies an anomalous operation of the PPO valves, and corrects the anomalous operation of the PPO valves by selectively configuring the surface actuated valve into the open configuration.

15. The system of claim **14** wherein pressure in the production string is monitored by the controller.

16. The system of claim **15** wherein pressure in a flow production line on surface is monitored by the controller, and wherein the controller identifies the anomalous operation of the PPO valves based on the monitored pressures.

17. The system of claim **14** wherein the surface controlled valve is at a greater depth than the PPO valves.

18. The system of claim **14** further comprising pressure sensors and control lines, and wherein the controller, pressure sensors, and control lines define a communication circuit.

* * * * *