



US 20140326393A1

(19) **United States**

(12) **Patent Application Publication**  
**DENNIS**

(10) **Pub. No.: US 2014/0326393 A1**

(43) **Pub. Date: Nov. 6, 2014**

(54) **VANADIUM-BASED FRIT MATERIALS,  
AND/OR METHODS OF MAKING THE SAME**

*E06B 3/66* (2006.01)  
*C03C 8/04* (2006.01)  
*C03C 27/06* (2006.01)

(71) Applicant: **Guardian Industries Corp.**, Auburn Hills, MI (US)

(52) **U.S. Cl.**  
CPC ... *C03C 8/06* (2013.01); *C03C 8/04* (2013.01);  
*C03C 27/06* (2013.01); *E06B 3/6612*  
(2013.01); *E06B 3/673* (2013.01); *C03C*  
*2205/00* (2013.01)

(72) Inventor: **Timothy A. DENNIS**, Bloomdale, OH (US)

USPC ..... **156/109**; 501/26; 501/25

(21) Appl. No.: **14/332,448**

(22) Filed: **Jul. 16, 2014**

(57) **ABSTRACT**

**Related U.S. Application Data**

(62) Division of application No. 12/929,875, filed on Feb. 22, 2011, now Pat. No. 8,802,203.

Certain example embodiments relate to improved seals for glass articles. Certain example embodiments relate to a composition used for sealing an insulated glass unit. In certain example embodiments the composition includes vanadium oxide, barium oxide, zinc oxide, and at least one additional additive. For instance, another additive that is a different metal oxide or different metal chloride may be provided. In certain example embodiments, a vacuum insulated glass unit includes first and second glass substrates that are sealed together with a seal that includes the above-described composition.

**Publication Classification**

(51) **Int. Cl.**  
*C03C 8/06* (2006.01)  
*E06B 3/673* (2006.01)

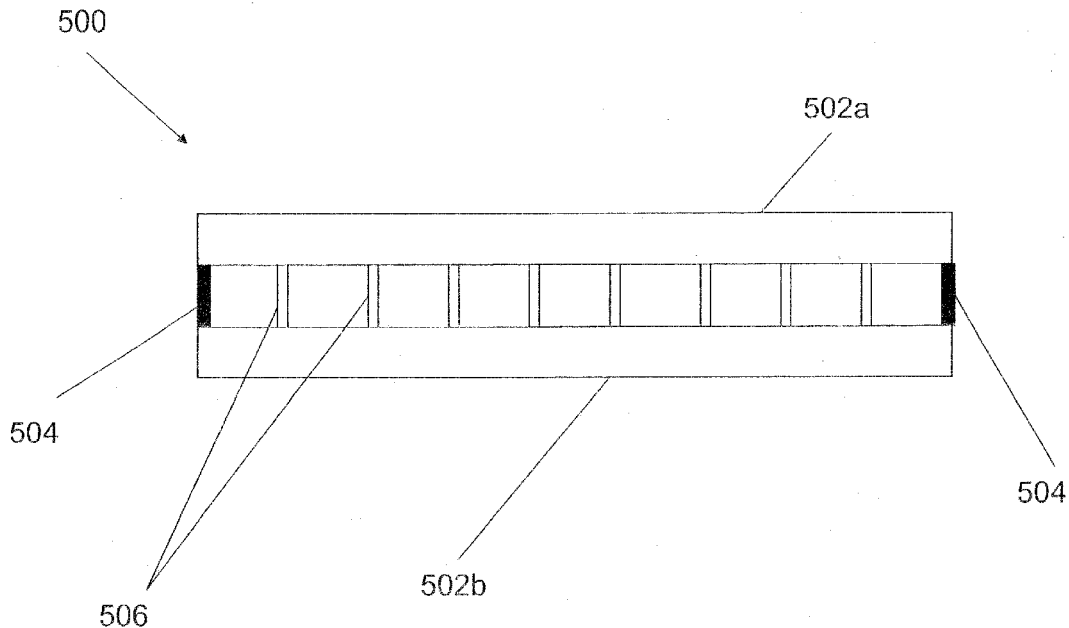

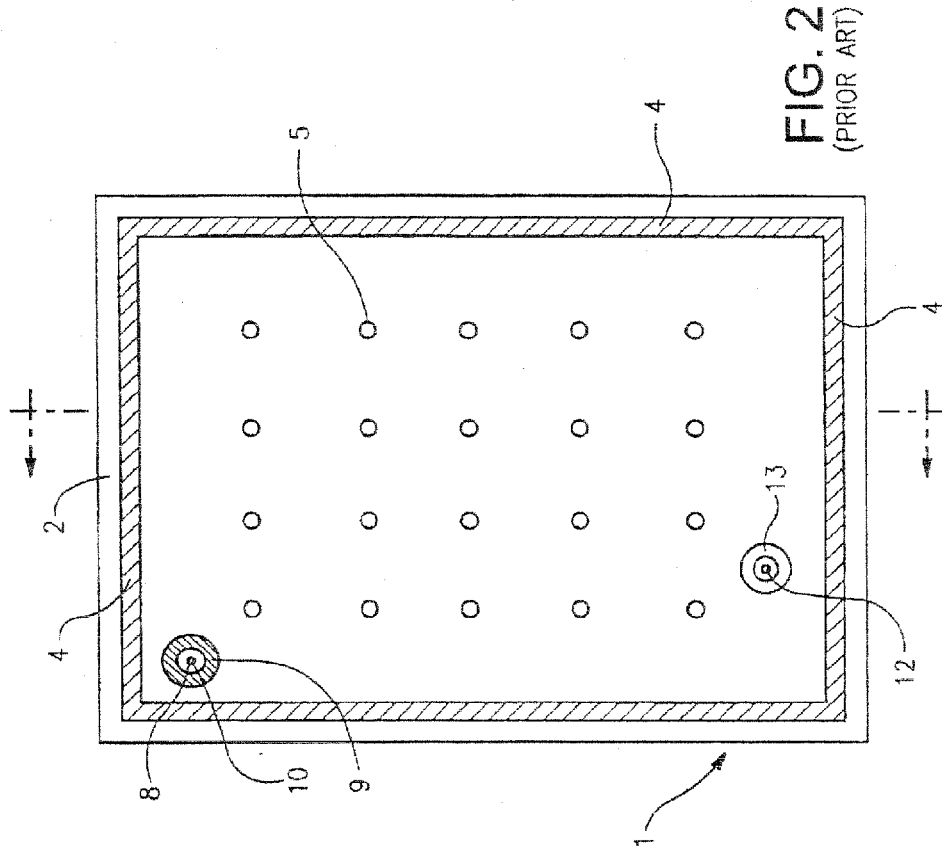

FIG. 1  
(PRIOR ART)

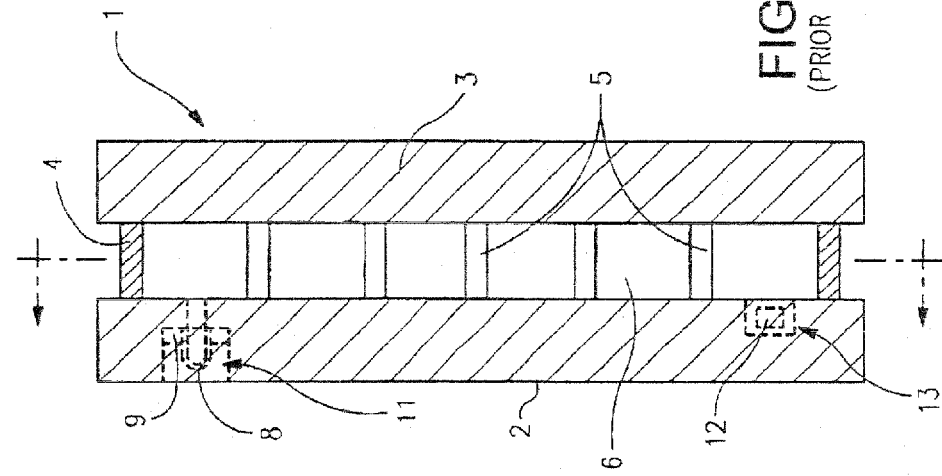

FIG. 2  
(PRIOR ART)

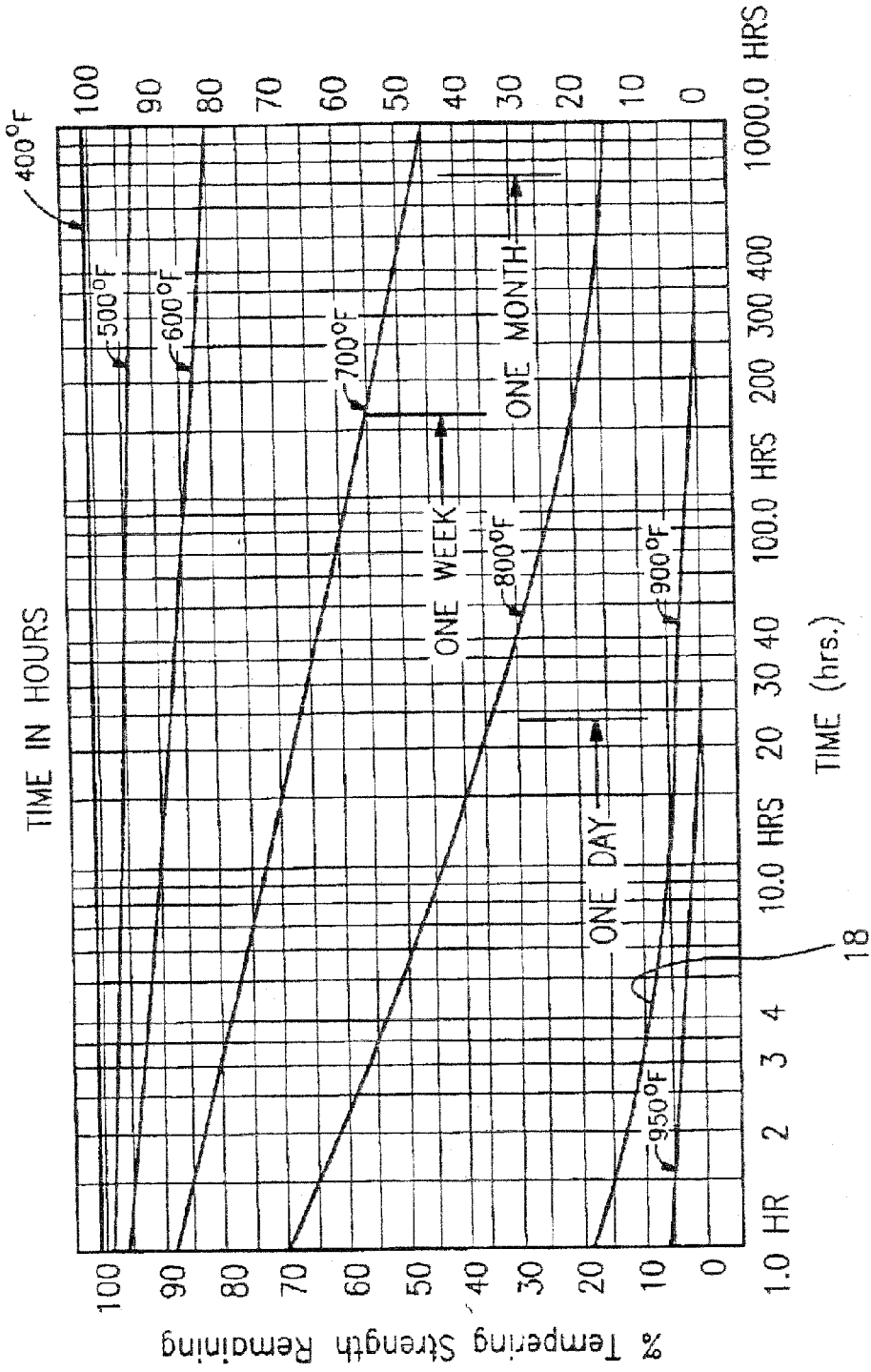

FIG. 3

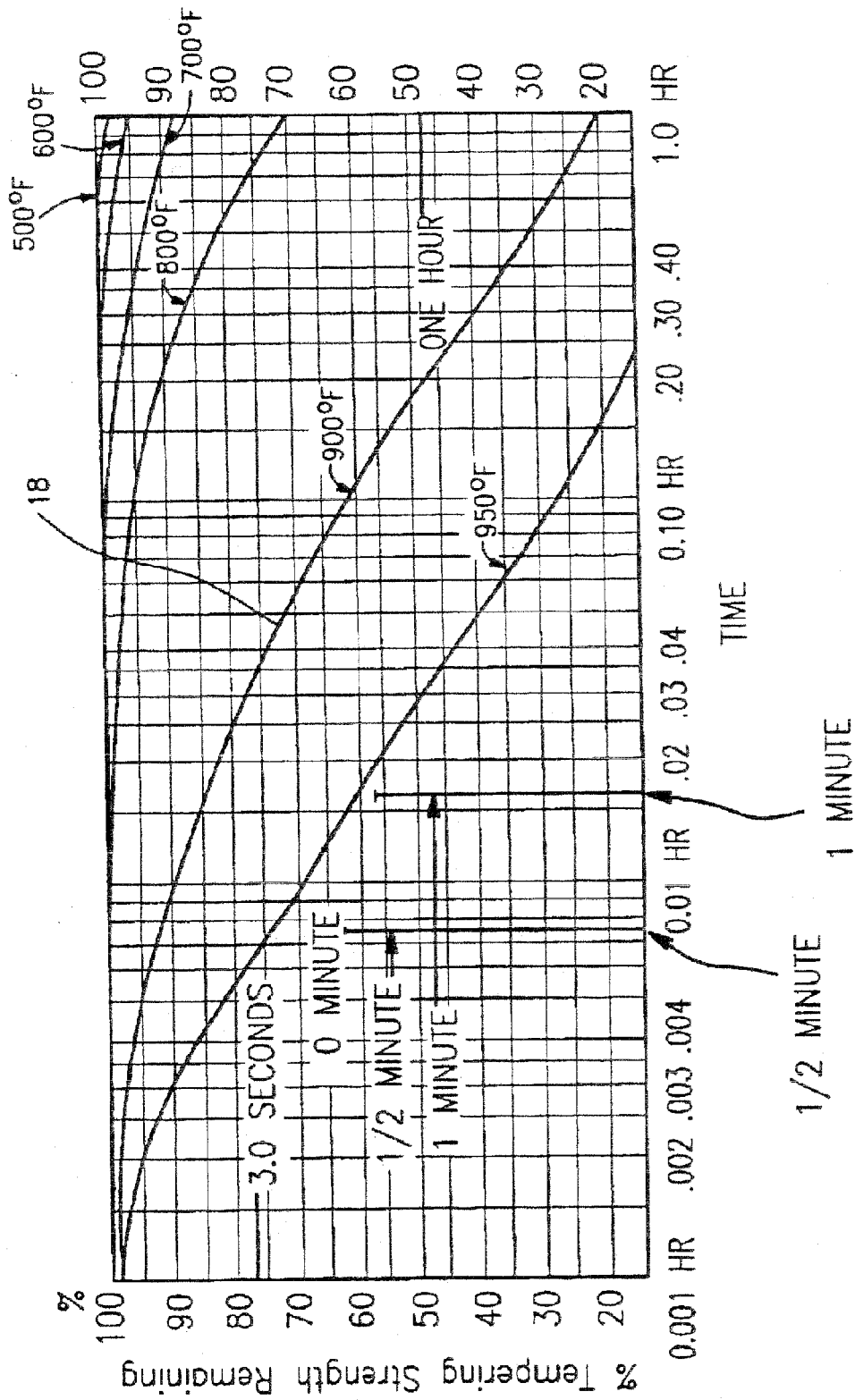

FIG. 4

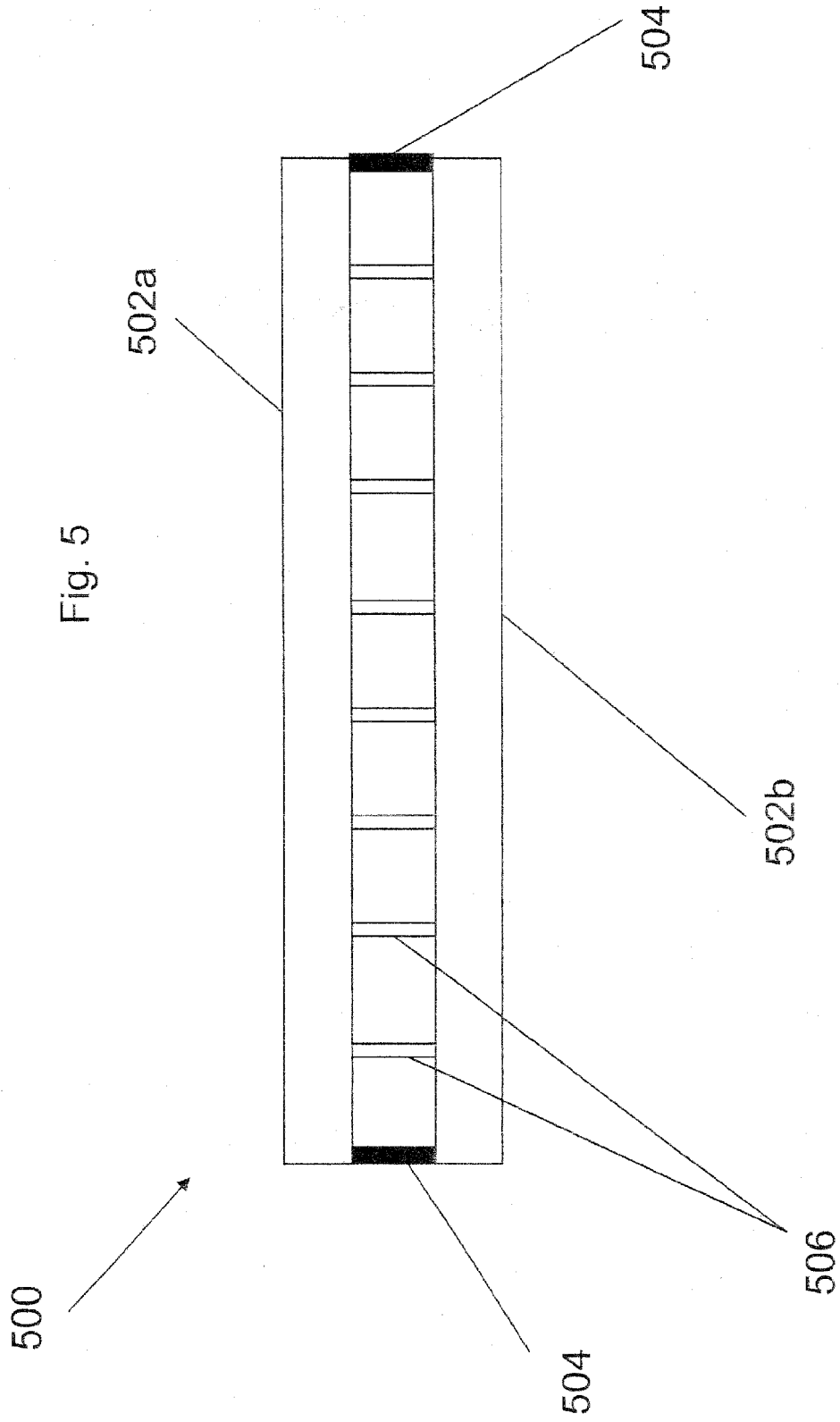

Fig. 6

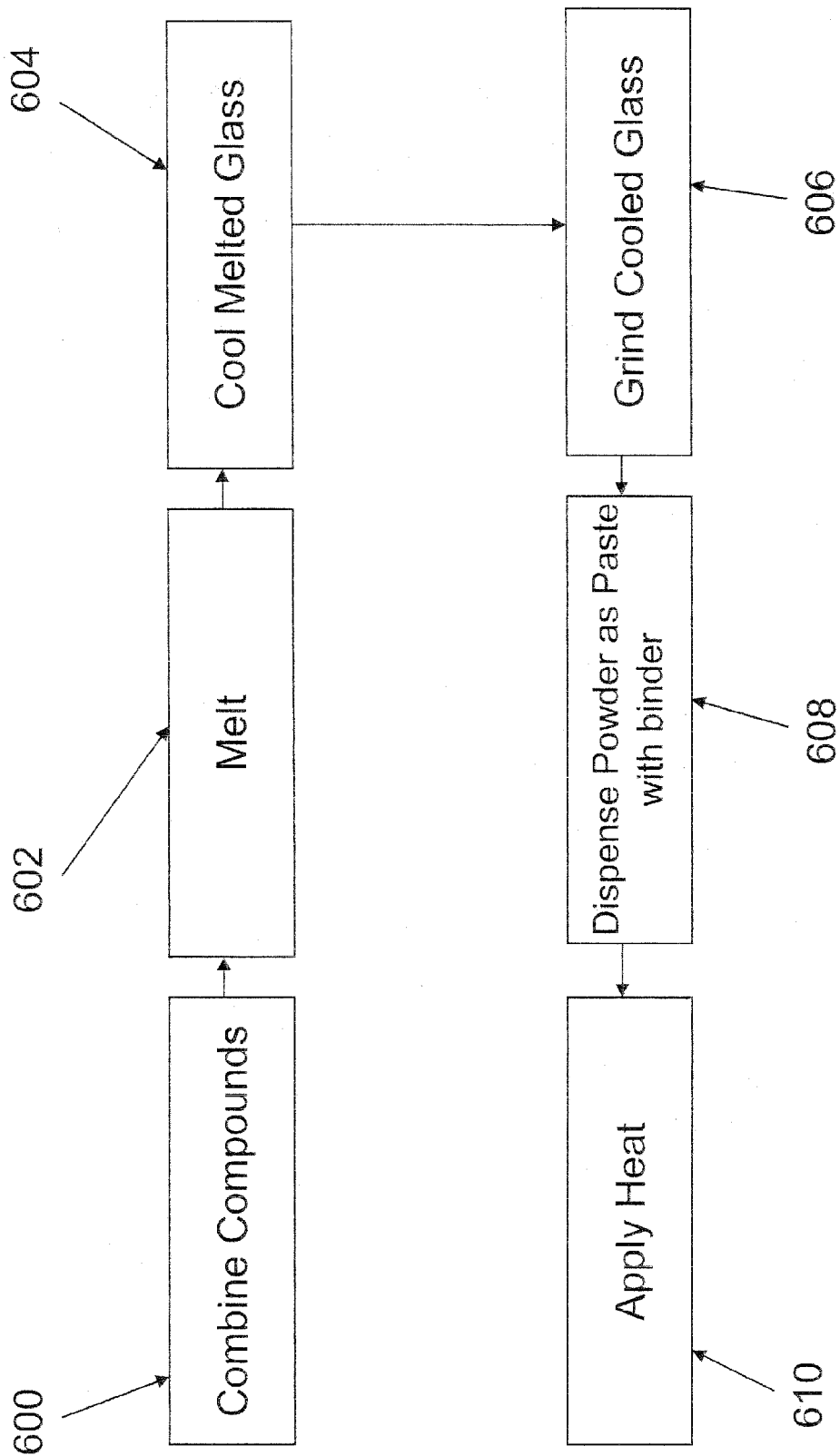



Fig. 7B

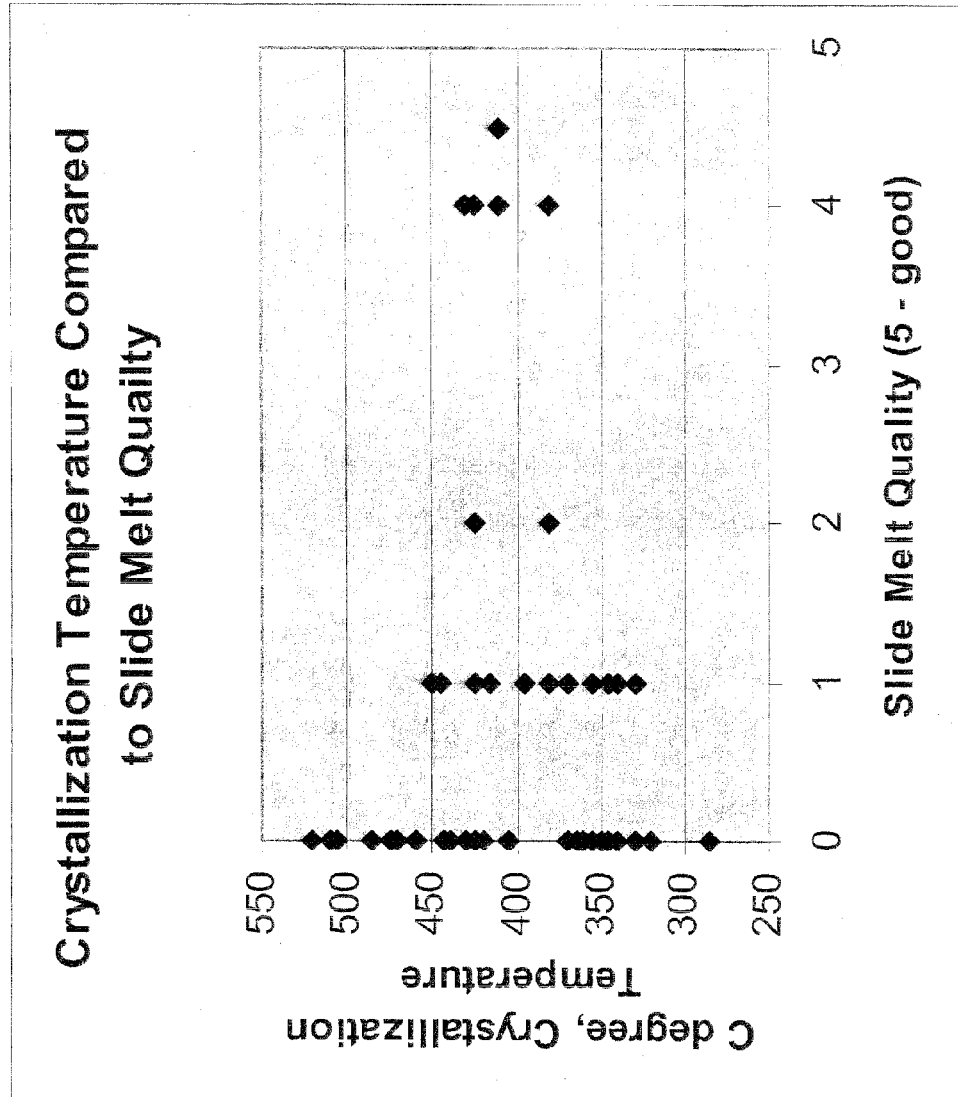



Fig. 7C

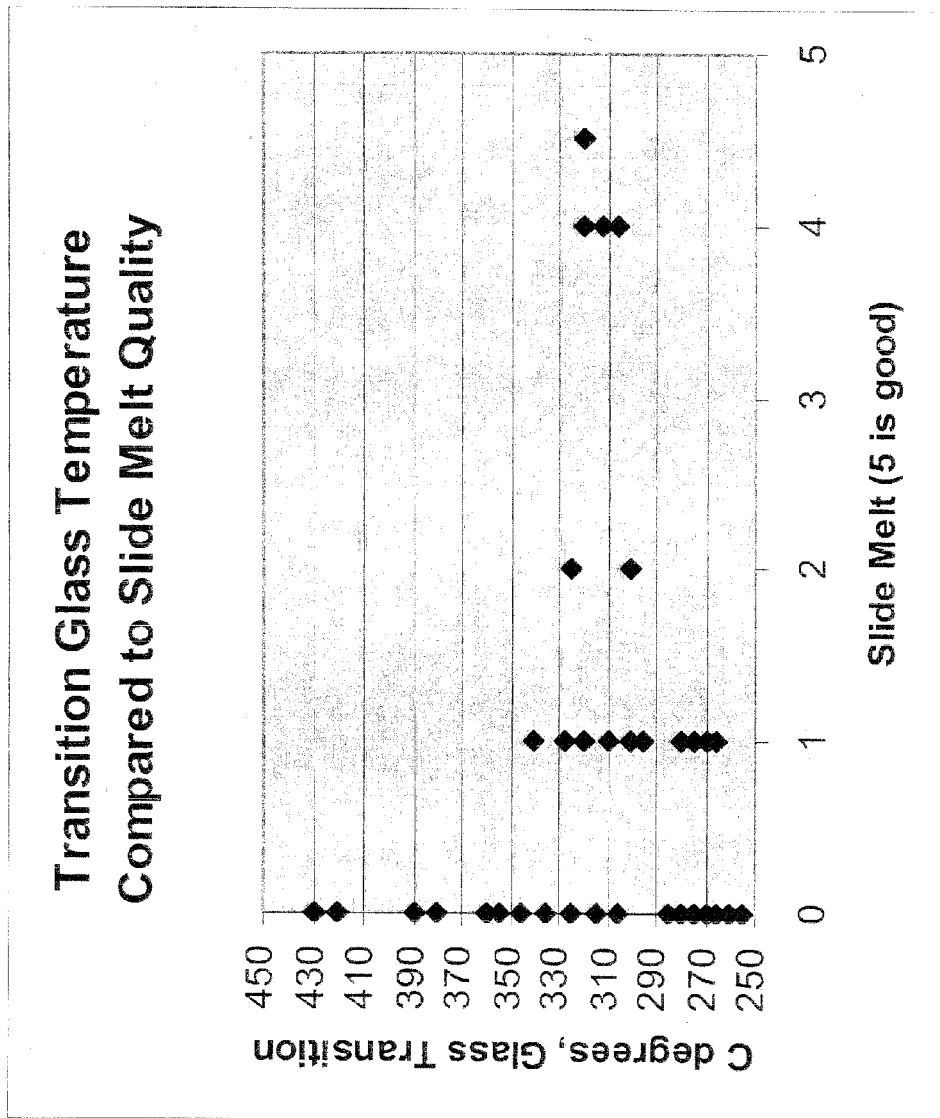

Fig. 7D

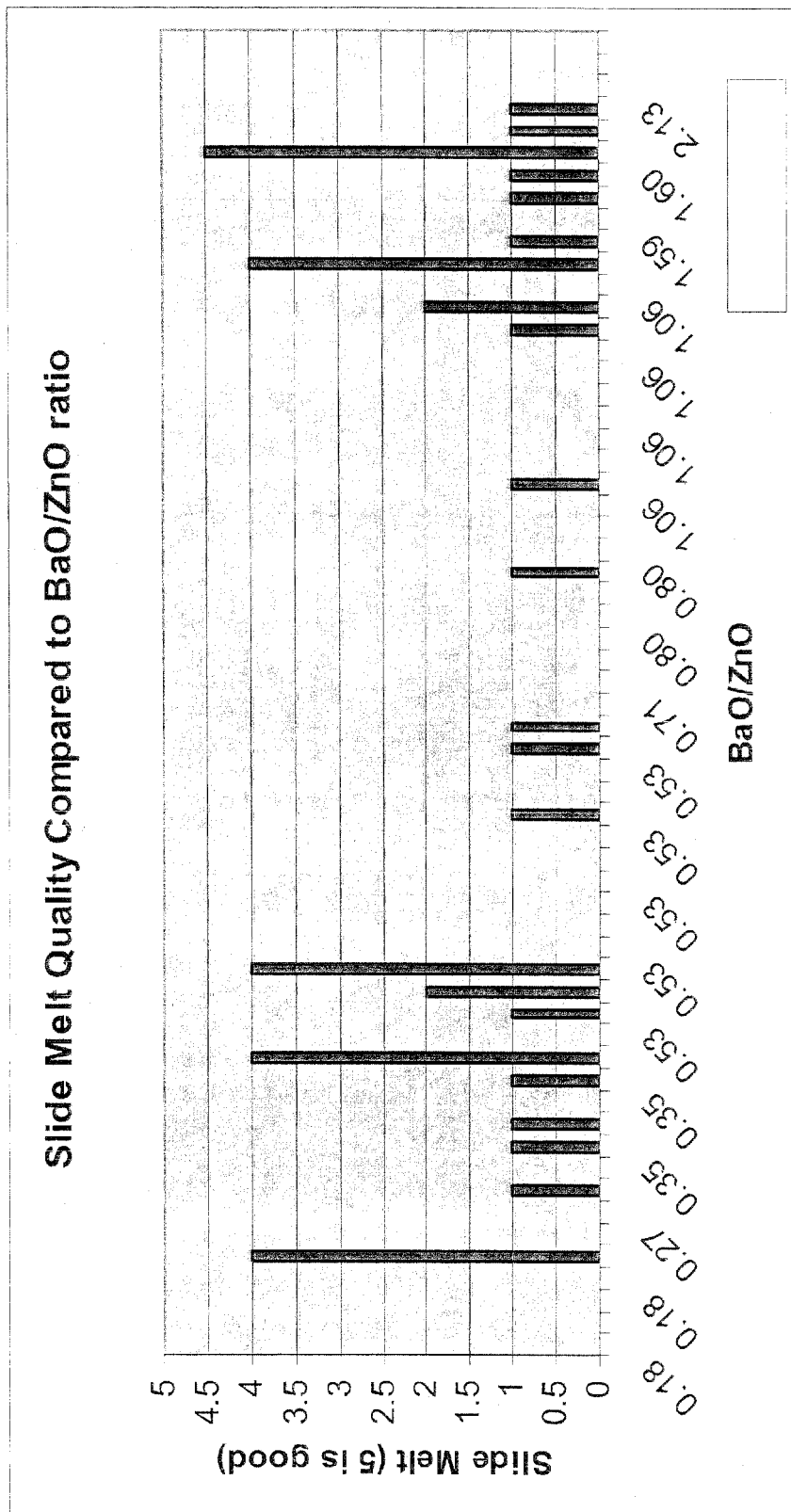

Fig. 8A

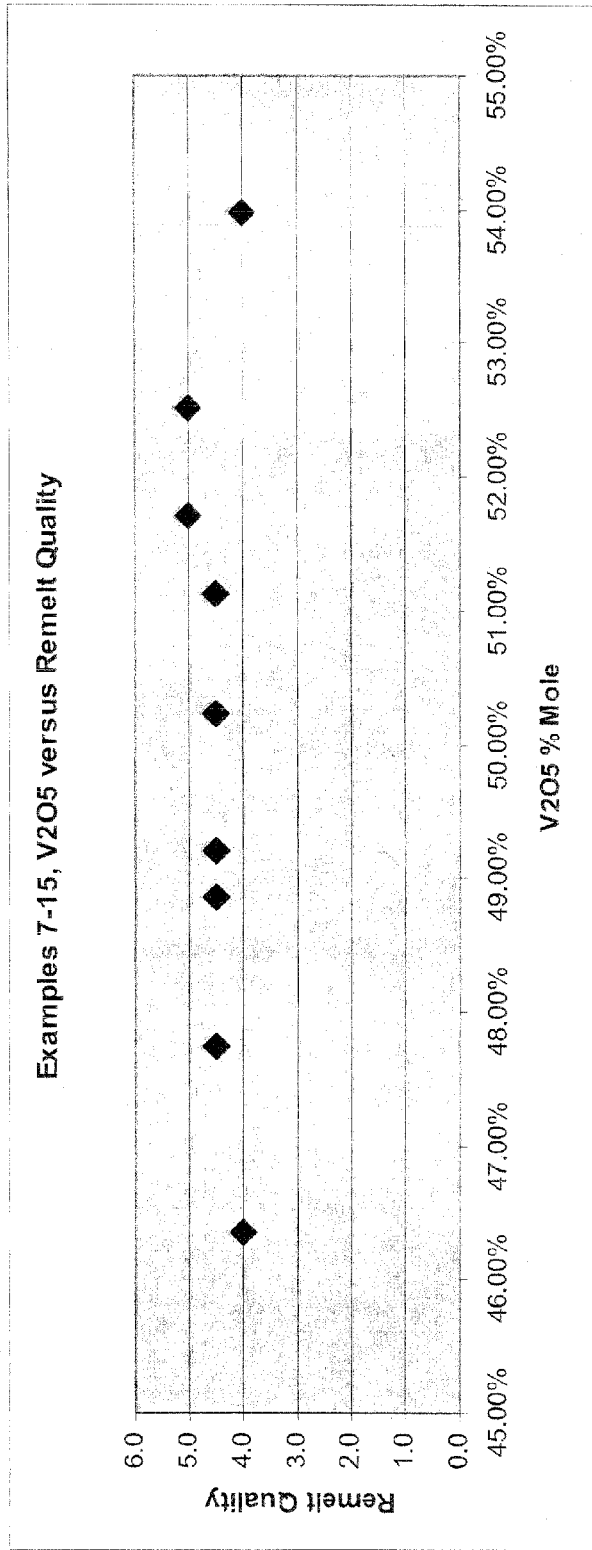

Fig. 8B

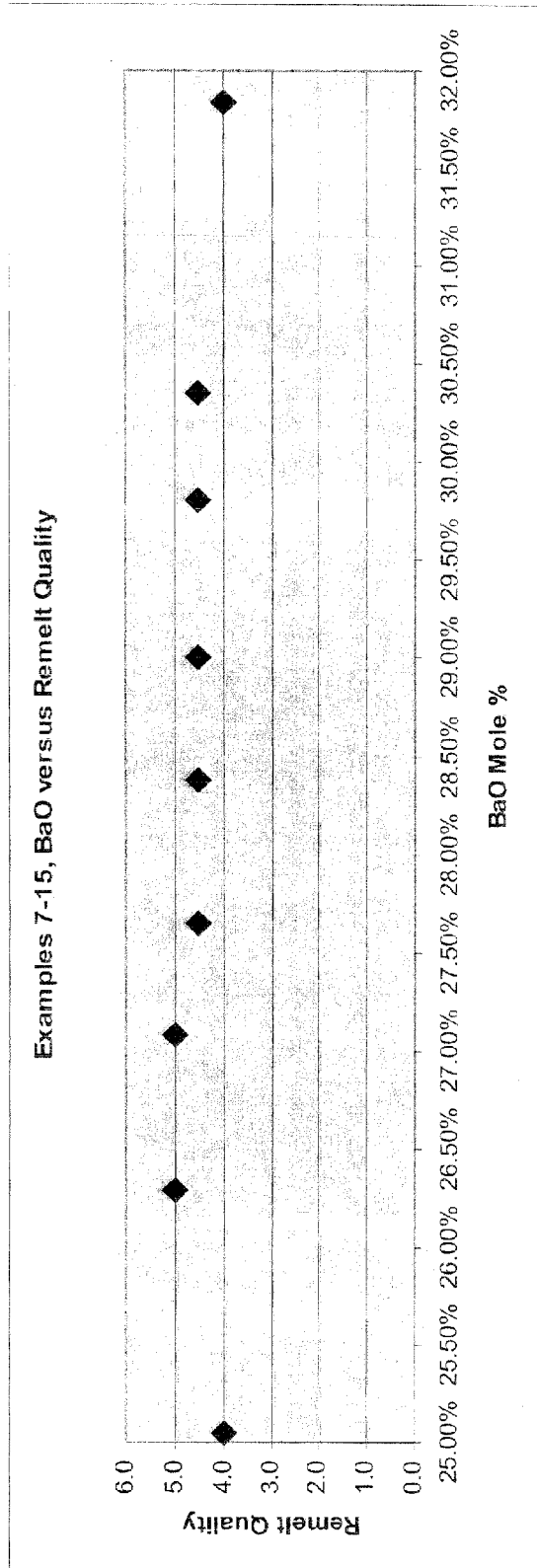

Fig. 8C

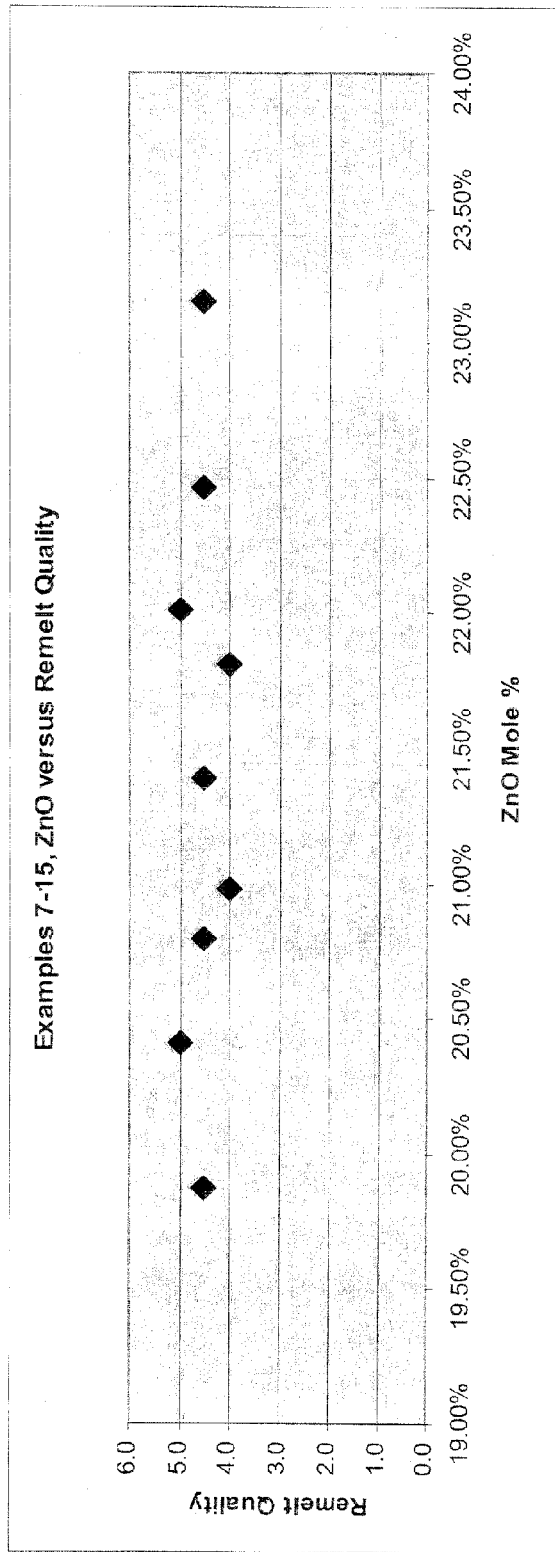

Fig. 9

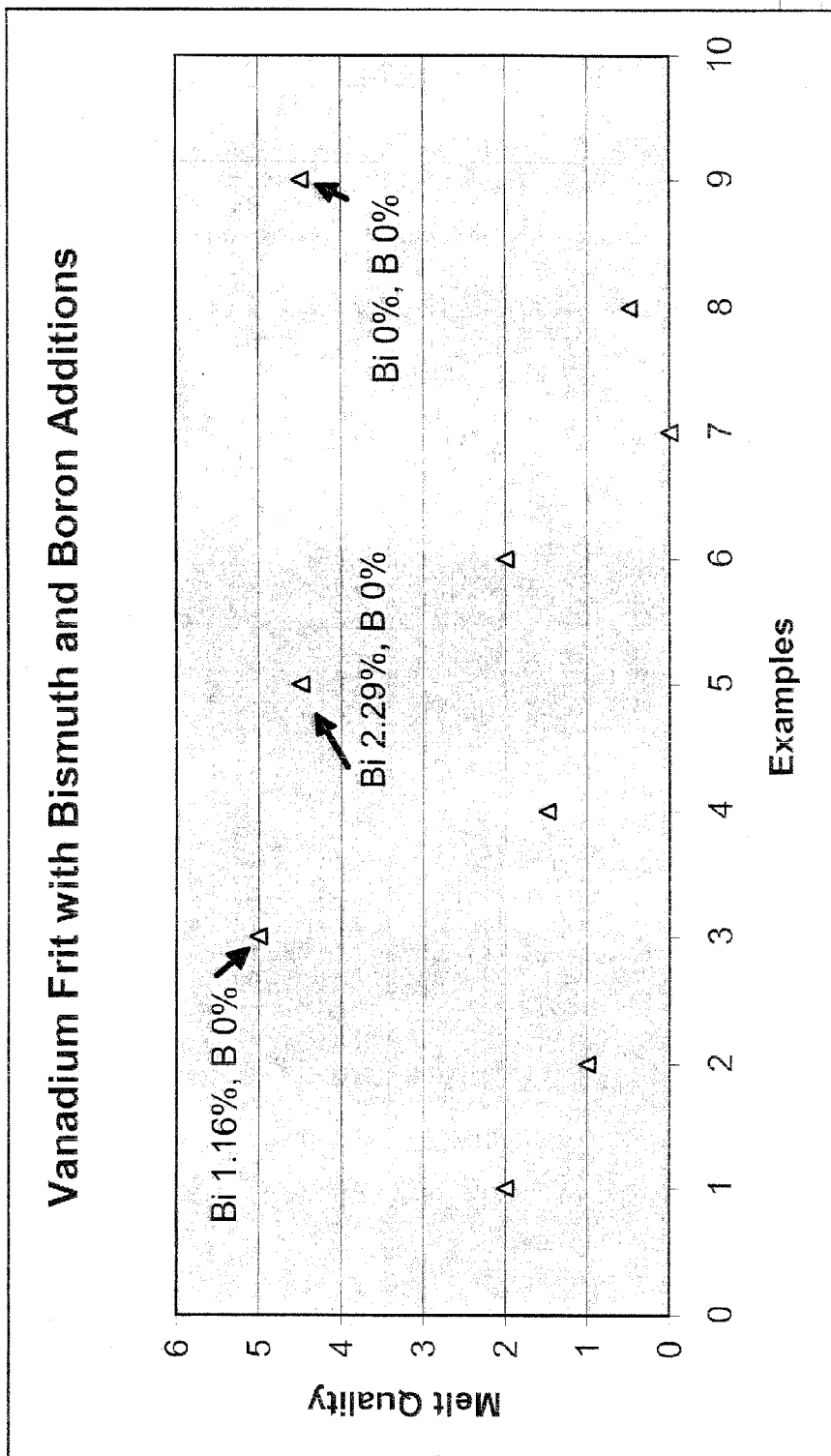

Fig. 10A

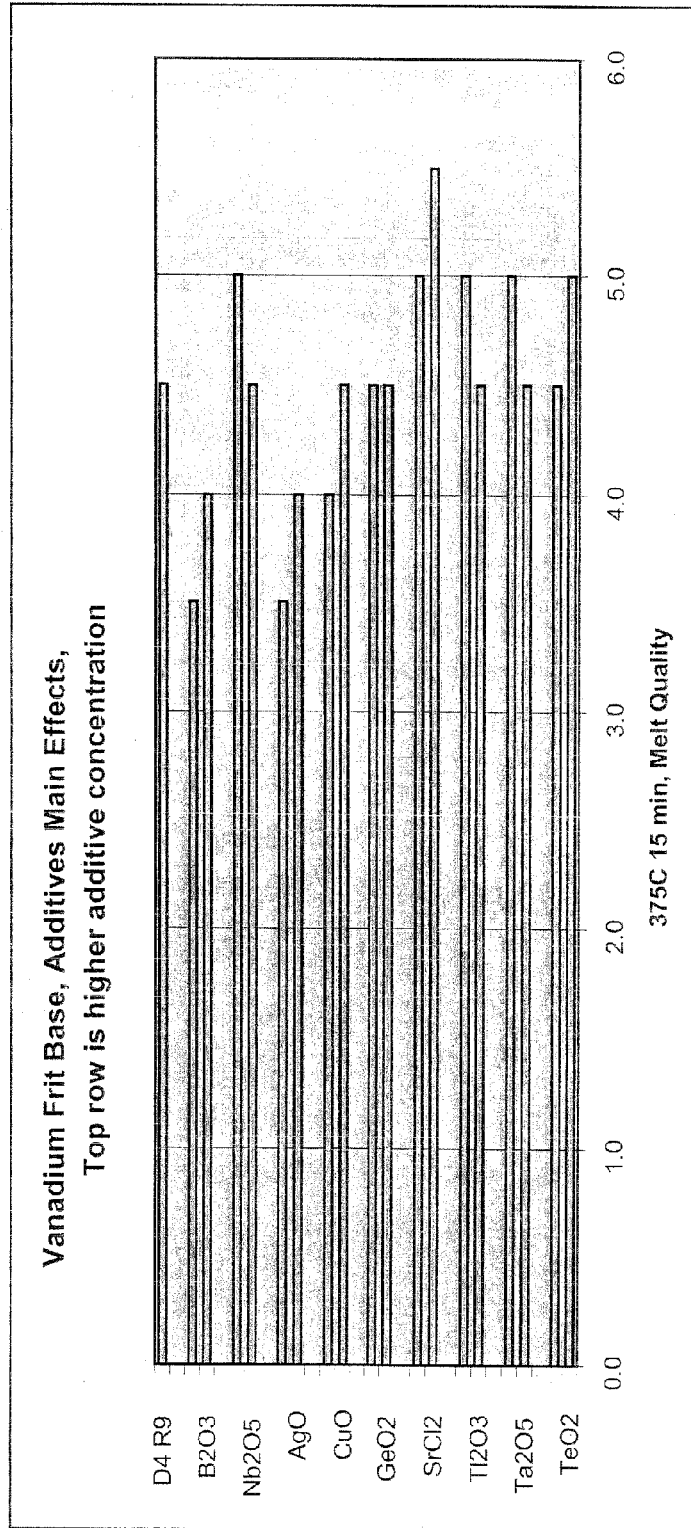

Fig. 10B

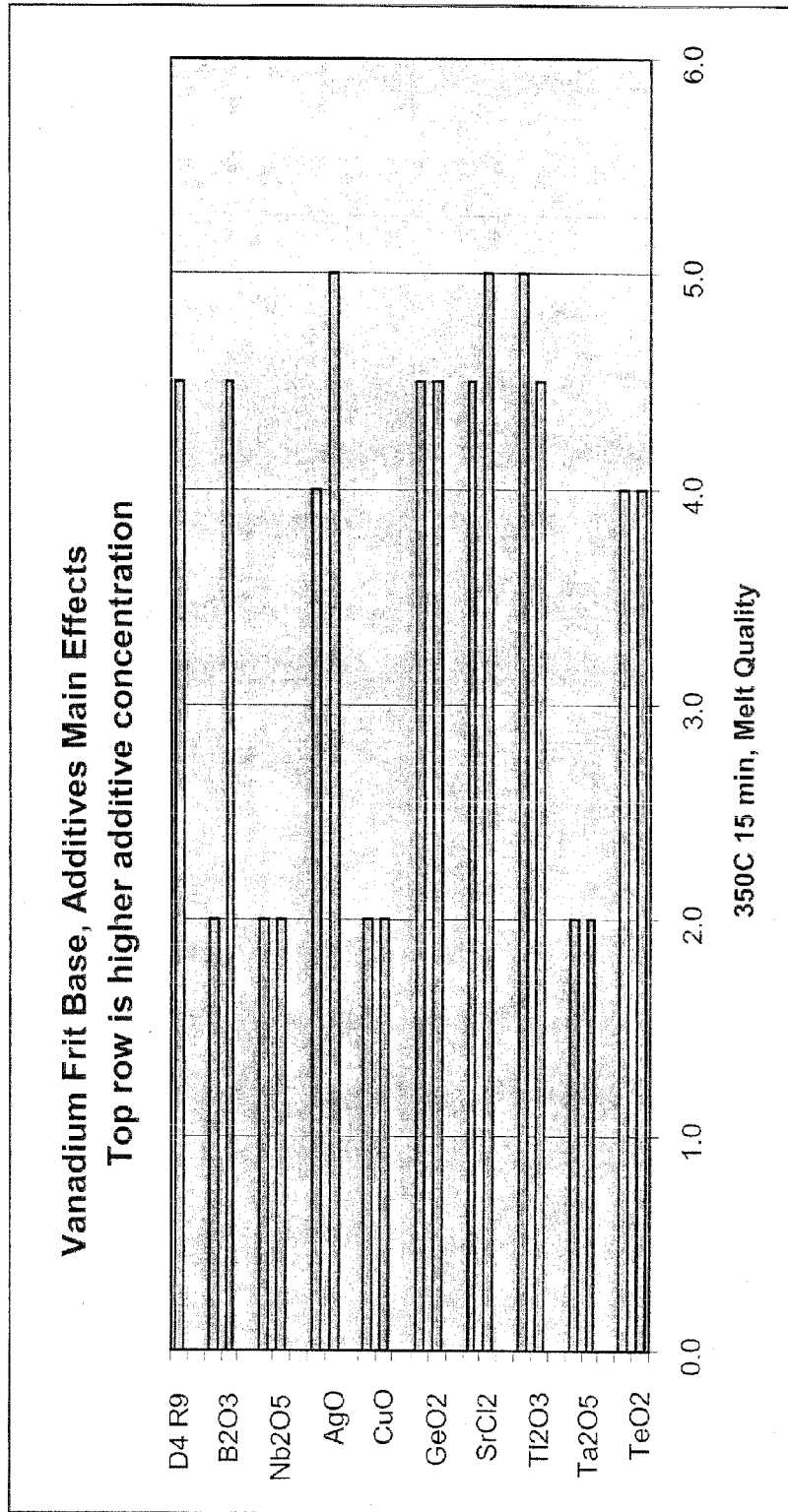



Fig. 10C

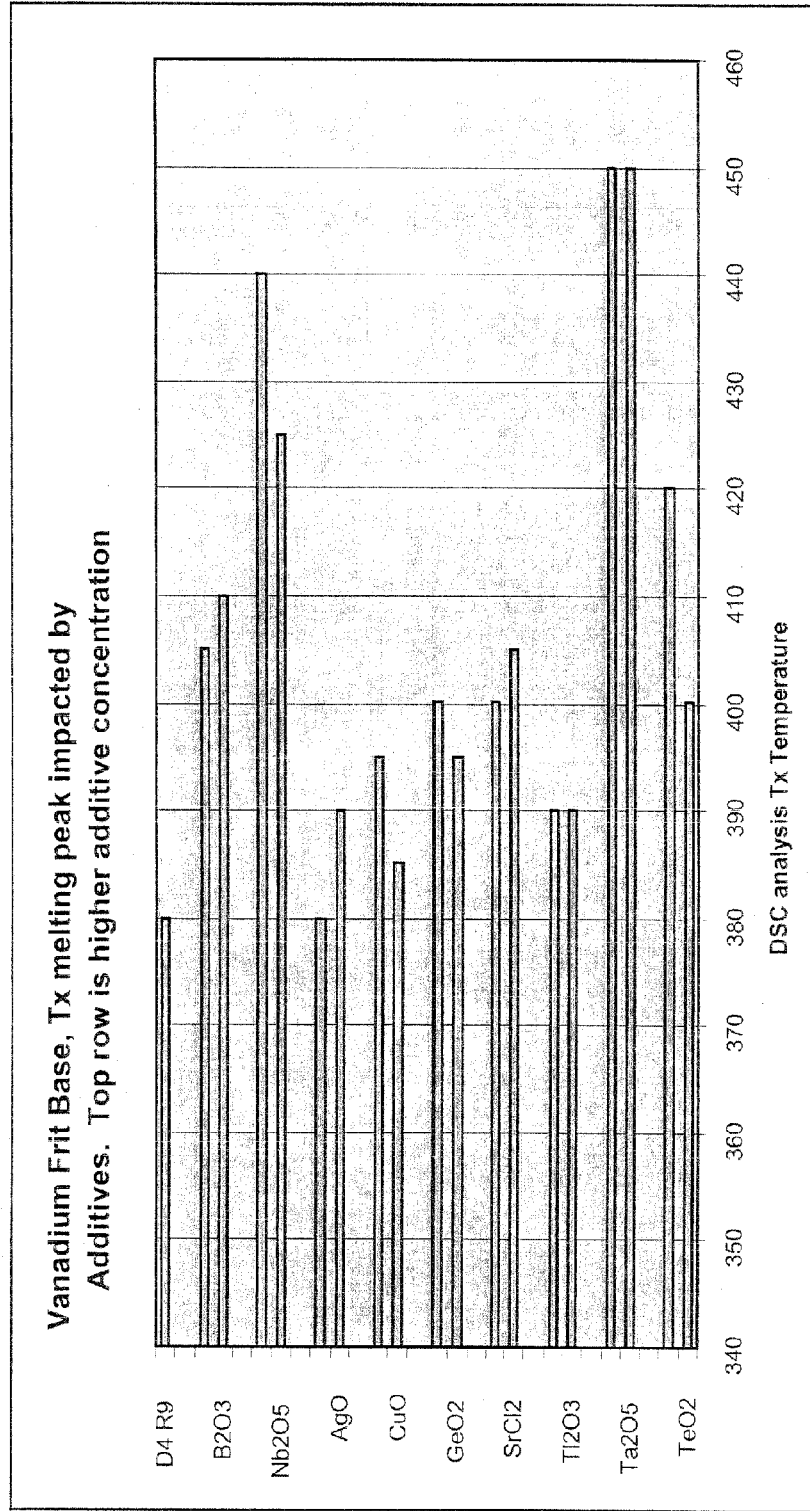

Fig. 11A

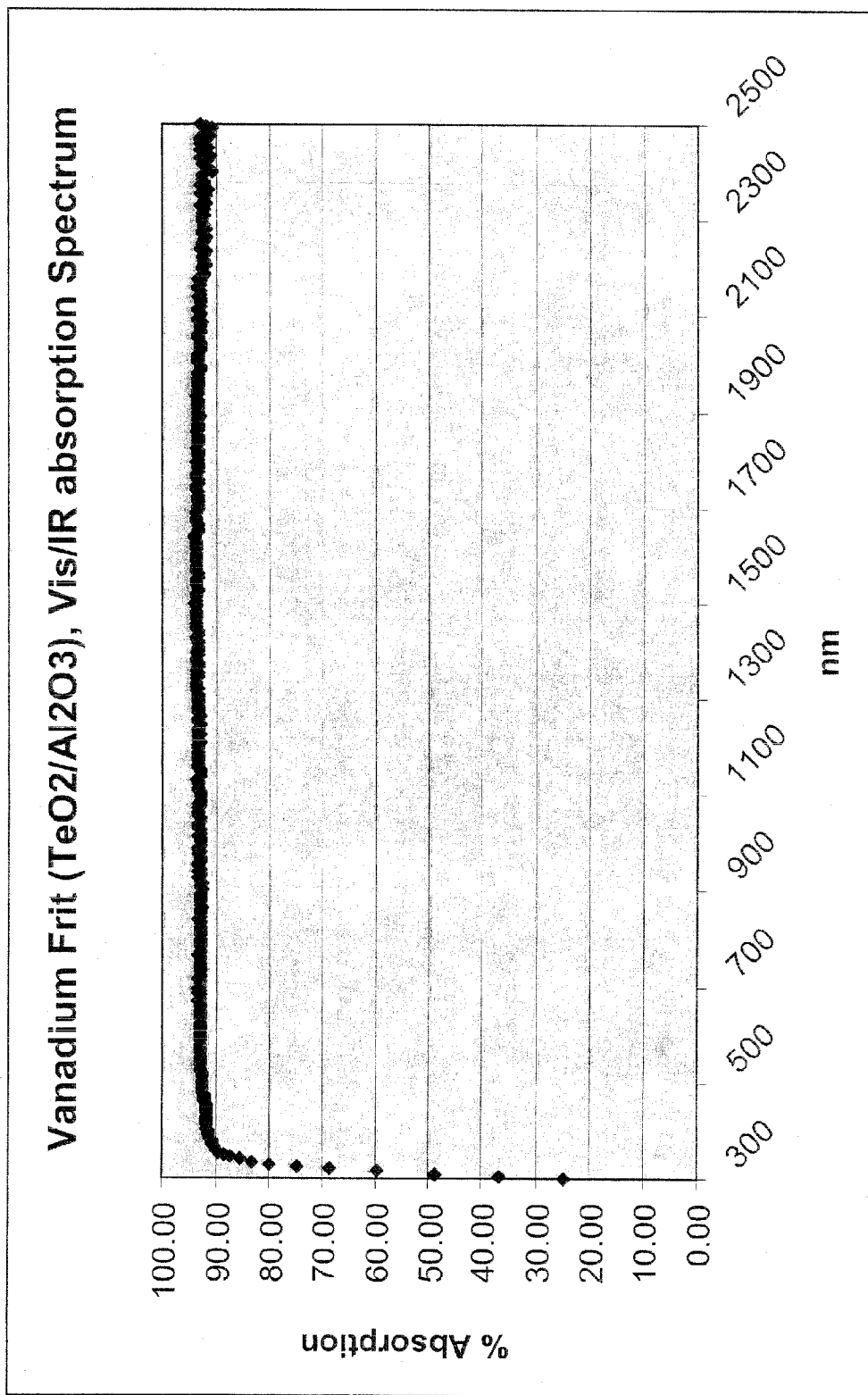

Fig. 11B

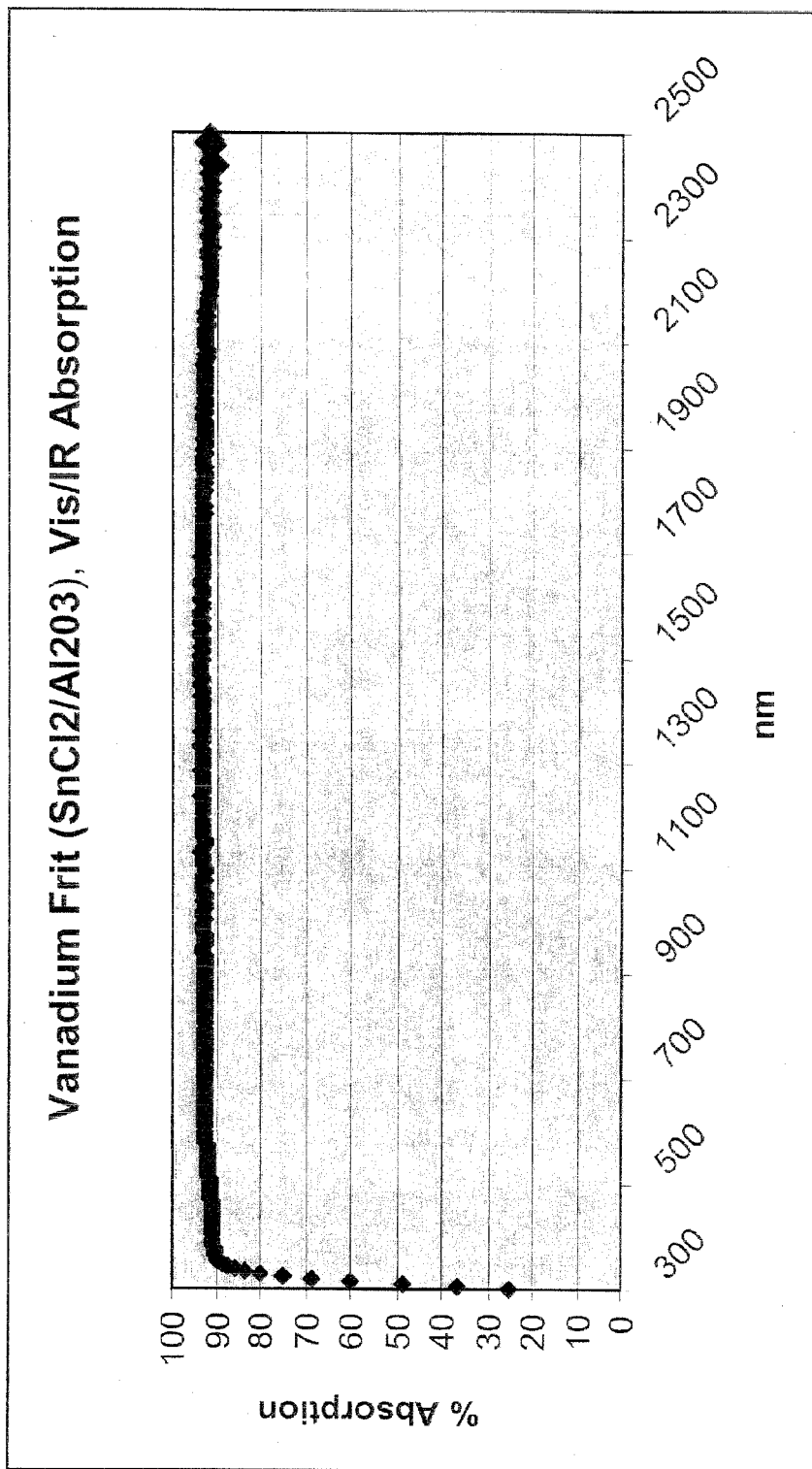
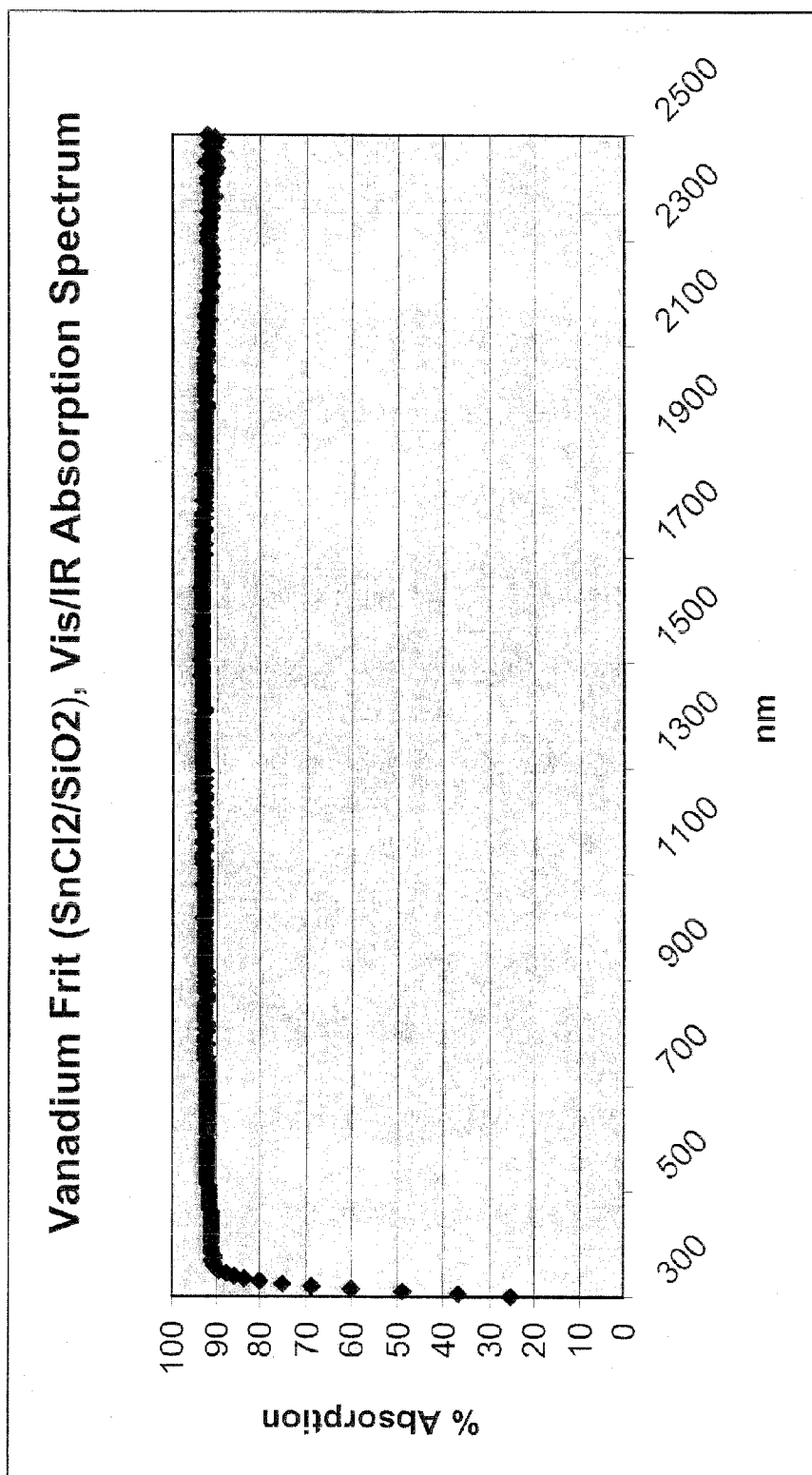

Fig. 11C



## VANADIUM-BASED FRIT MATERIALS, AND/OR METHODS OF MAKING THE SAME

### FIELD OF THE INVENTION

[0001] Certain example embodiments of this invention relate to improved frit materials for glass articles (e.g., for use in vacuum insulated glass or VIG units), and/or methods of making the same, as well as articles including such improved frit materials and/or methods of making the same. More particularly, certain example embodiments relate to vanadium-based frit materials having a reduced melting point, and/or methods of making the same. In certain example embodiments, the improved insulated seals are used in connection with vacuum insulated glass (VIG) units, and/or a method is provided for sealing VIG units with the improved seals.

### BACKGROUND AND SUMMARY OF EXAMPLE EMBODIMENTS OF THE INVENTION

[0002] Vacuum IG units are known in the art. For example, see U.S. Pat. Nos. 5,664,395, 5,657,607, and 5,902,652, the disclosures of which are all hereby incorporated herein by reference.

[0003] FIGS. 1-2 illustrate a conventional vacuum IG unit (vacuum IG unit or VIG unit). Vacuum IG unit 1 includes two spaced apart glass substrates 2 and 3, which enclose an evacuated or low pressure space 6 there between. Glass sheets/substrates 2 and 3 are interconnected by peripheral or edge seal of fused solder glass 4 and an array of support pillars or spacers 5.

[0004] Pump out tube 8 is hermetically sealed by solder glass 9 to an aperture or hole 10 which passes from an interior surface of glass sheet 2 to the bottom of recess 11 in the exterior face of sheet 2. A vacuum is attached to pump out tube 8 so that the interior cavity between substrates 2 and 3 can be evacuated to create a low pressure area or space 6. After evacuation, tube 8 is melted to seal the vacuum. Recess 11 retains sealed tube 8. Optionally, a chemical getter 12 may be included within recess 13.

[0005] Conventional vacuum IG units, with their fused solder glass peripheral seals 4, have been manufactured as follows. Glass frit in a solution (ultimately to form solder glass edge seal 4) is initially deposited around the periphery of substrate 2. The other substrate 3 is brought down over top of substrate 2 so as to sandwich spacers 5 and the glass frit/solution there between. The entire assembly including sheets 2, 3, the spacers, and the seal material is then heated to a temperature of approximately 500° C., at which point the glass frit melts, wets the surfaces of the glass sheets 2, 3, and ultimately forms hermetic peripheral or edge seal 4. This approximately 500° C. temperature is maintained for from about one to eight hours. After formation of the peripheral/edge seal 4 and the seal around tube 8, the assembly is cooled to room temperature. It is noted that column 2 of U.S. Pat. No. 5,664,395 states that a conventional vacuum IG processing temperature is approximately 500° C. for one hour. Inventors Lenzen, Turner and Collins of the '395 patent have stated that "the edge seal process is currently quite slow: typically the temperature of the sample is increased at 200° C. per hour, and held for one hour at a constant value ranging from 430° C. and 530° C. depending on the solder glass composition." After formation of edge seal 4, a vacuum is drawn via the tube to form low pressure space 6.

[0006] The composition of conventional edge seals are known in the art. See, for example, U.S. Pat. Nos. 3,837,866; 4,256,495; 4,743,302; 5,051,381; 5,188,990; 5,336,644; 5,534,469; 7,425,518, and U.S. Publication No. 2005/0233885, the disclosures of which are all hereby incorporated herein by reference.

[0007] Unfortunately, the aforesaid high temperatures and long heating times of the entire assembly utilized in the formulation of edge seal 4 are undesirable. This is especially the case when it is desired to use a heat strengthened or tempered glass substrate(s) 2, 3 in the vacuum IG unit. As shown in FIGS. 3-4, tempered glass loses temper strength upon exposure to high temperatures as a function of heating time. Moreover, such high processing temperatures may adversely affect certain low-E coating(s) that may be applied to one or both of the glass substrates in certain instances.

[0008] FIG. 3 is a graph illustrating how fully thermally tempered plate glass loses original temper upon exposure to different temperatures for different periods of time, where the original center tension stress is 3,200 MU per inch. The x-axis in FIG. 3 is exponentially representative of time in hours (from 1 to 1,000 hours), while the y-axis is indicative of the percentage of original temper strength remaining after heat exposure. FIG. 4 is a graph similar to FIG. 3, except that the x-axis in FIG. 4 extends from zero to one hour exponentially.

[0009] Seven different curves are illustrated in FIG. 3, each indicative of a different temperature exposure in degrees Fahrenheit (° F.). The different curves/lines are 400° F. (across the top of the FIG. 3 graph), 500° F., 600° F., 700° F., 800° F., 900° F., and 950° F. (the bottom curve of the FIG. 3 graph). A temperature of 900° F. is equivalent to approximately 482° C., which is within the range utilized for forming the aforesaid conventional solder glass peripheral seal 4 in FIGS. 1-2. Thus, attention is drawn to the 900° F. curve in FIG. 3, labeled by reference number 18. As shown, only 20% of the original temper strength remains after one hour at this temperature (900° F. or 482° C.). Such a significant loss (i.e., 80% loss) of temper strength may be undesirable.

[0010] As seen in FIGS. 3-4, the percentage of remaining tempering strength varies based on the temperature that is exposed to the tempered glass. For example, at 900° F. only about 20% of the original temper strength remains. When the temperature that the sheet is exposed to is reduced to 800° F., about 428° C., the amount of strength remaining is about 70%. Finally, a reduction in temperature to about 600° F., about 315° C., results in about 95% of the original temper strength of the sheet remaining. As will be appreciated, it is desirable to reduce any temper strength losses as a result of exposing a tempered sheet of glass to high temperatures.

[0011] As noted above, the creation of VIG units includes the creation of a hermetic seal that can withstand the pressure applied from the vacuum created on inside of the unit. As also discussed above, the creation of the seal may conventionally involve temperatures of at or above 500° C. These temperatures are required in order to obtain a high enough temperature in order for the frit material used for the seal to melt and form the required seal for the VIG units. As shown above, such a temperature can result in a strength reduction for VIG units using tempered glass.

[0012] One conventional solution to sealing glass substrates together is to use an epoxy. However, in the case of VIG units, epoxy compositions may be insufficient to hold a seal on a vacuum. Furthermore, epoxies may be susceptible to

environmental factors that may further reduce their effectiveness when applied to VIG units.

**[0013]** Another conventional solution is to use a frit solution that contains lead. As is known, lead has a relatively low melting point. Accordingly, temperatures for sealing the VIG units may not need to be as high for other frit materials, and thus the tempering strength of tempered glass substrates may not be reduced by the same amount required for other frit based materials. However, while lead based frits may resolve the above structural issues, the usage of lead in the frit may create new problems. Specifically, the health consequences to the population for products that contain lead. Additionally, certain countries (e.g., in the European Union) may impose strict requirements on the amount of lead that can be contained in a given product. Indeed, some countries (or customers) may require products that are completely lead-free.

**[0014]** Thus, it will be appreciated that techniques for creating improved seals for glass articles are continuously sought after. It also will be appreciated that there exists a need in the art for improved seals and the like that can be integrated with tempered glass units, such as, for example, VIG units. The seals may be designed to allow for reduced temperature sealing such that annealed or tempered glass can be sealed without detrimental impact on the properties of the glass.

**[0015]** In certain example embodiments, a frit material having a composition is provided. The frit material may include vanadium oxide between about 50% and 60% weight, barium oxide between about 27% and 33% weight, and zinc oxide between about 9% and 12% weight. In certain example embodiments, the frit material may also include at least one additive selected from among: Ta<sub>2</sub>O<sub>5</sub>, Ti<sub>2</sub>O<sub>3</sub>, SrCl<sub>2</sub>, GeO<sub>2</sub>, CuO, AgO, Nb<sub>2</sub>O<sub>5</sub>, B<sub>2</sub>O<sub>3</sub>, MgO, SiO<sub>2</sub>, TeO<sub>2</sub>, Ti<sub>2</sub>O<sub>3</sub>, Y<sub>2</sub>O<sub>3</sub>, SnF<sub>2</sub>, SnO<sub>2</sub>, CuCl, SnCl<sub>2</sub>, CeO<sub>2</sub>, AgCl, In<sub>2</sub>O<sub>3</sub>, SnO, SrO, MgO, and Al<sub>2</sub>O<sub>3</sub>.

**[0016]** In certain example embodiments, a vacuum insulated glass (VIG) unit is provided. The VIG unit may include first and second substantially parallel, spaced apart glass substrates. An edge seal is provided around a periphery of the first and second substrates to form a hermetic seal there between and at least partially defining a gap between the first and second substrates. The gap defined between the first and second substrates is at a pressure less than atmospheric. The edge seal includes a frit material, e.g., as made from a base composition as described herein.

**[0017]** In certain example embodiments, a method of making a frit material is provided. A base composition is provided to a holder. The base composition includes vanadium oxide between about 50% and 60% weight, barium oxide between about 27% and 33% weight, zinc oxide between about 9% and 12% weight, and at least one additive selected from among: Ta<sub>2</sub>O<sub>5</sub>, Ti<sub>2</sub>O<sub>3</sub>, SrCl<sub>2</sub>, GeO<sub>2</sub>, CuO, AgO, Nb<sub>2</sub>O<sub>5</sub>, B<sub>2</sub>O<sub>3</sub>, MgO, SiO<sub>2</sub>, TeO<sub>2</sub>, Ti<sub>2</sub>O<sub>3</sub>, Y<sub>2</sub>O<sub>3</sub>, SnF<sub>2</sub>, SnO<sub>2</sub>, CuCl, SnCl<sub>2</sub>, CeO<sub>2</sub>, AgCl, In<sub>2</sub>O<sub>3</sub>, SnO, SrO, MgO, and Al<sub>2</sub>O<sub>3</sub>. The base composition is melted. The base composition is cooled or allowed to cool, forming an intermediate glass article. The intermediate glass article is ground to make the frit material.

**[0018]** In certain example embodiments, a method of making a vacuum insulated glass (VIG) unit is provided. First and second glass substrates in substantially parallel, spaced apart relation to one another are provided. The first and second glass substrates using a frit material are sealed together, with a gap being defined between the first and second substrates. The sealing being performed by melting the frit material at a temperature of no more than about 375 degrees C. Where the

frit material has been formed from a base composition including vanadium oxide between about 50% and 60% weight, barium oxide between about 27% and 33% weight, zinc oxide between about 9% and 12% weight, and at least one oxide or chloride-base additive.

**[0019]** In certain example embodiments, a frit material having a composition is provided. The frit material may include vanadium oxide between about 50% and 60% weight, barium oxide between about 27% and 33% weight, and zinc oxide between about 9% and 12% weight. The frit material includes at least a first and second additive selected from among SiO<sub>2</sub>, SnCl<sub>2</sub>, Al<sub>2</sub>O<sub>3</sub>, and TeO<sub>2</sub>.

**[0020]** Certain example embodiments may include at least two additives. For example SnCl<sub>2</sub> and SiO<sub>2</sub>. Certain example embodiments may include three or four additives selected from among SiO<sub>2</sub>, SnCl<sub>2</sub>, Al<sub>2</sub>O<sub>3</sub>, and TeO<sub>2</sub>.

**[0021]** The features, aspects, advantages, and example embodiments described herein may be combined in any suitable combination or sub-combination to realize yet further embodiments.

#### BRIEF DESCRIPTION OF THE DRAWINGS

**[0022]** These and other features and advantages may be better and more completely understood by reference to the following detailed description of exemplary illustrative embodiments in conjunction with the drawings, of which:

**[0023]** FIG. 1 is a cross-sectional view of a conventional vacuum IG unit;

**[0024]** FIG. 2 is a top plan view of the bottom substrate, edge seal, and spacers of the FIG. 1 vacuum IG unit taken along the section line illustrated in FIG. 1;

**[0025]** FIG. 3 is a graph correlating time (hours) versus percent tempering strength remaining, illustrating the loss of original temper strength for a thermally tempered sheet of glass after exposure to different temperatures for different periods of time;

**[0026]** FIG. 4 is a graph correlating time versus percent tempering strength remaining similar to that of FIG. 3, except that a smaller time period is provided on the x-axis;

**[0027]** FIG. 5 is cross-sectional view of a vacuum insulated glass unit according to certain example embodiments;

**[0028]** FIG. 6 is a flowchart illustrating a process for making a vacuum insulated glass unit with a frit material according to certain example embodiments;

**[0029]** FIGS. 7A-7D are graphs summarizing properties of compositions according to certain example embodiments;

**[0030]** FIGS. 8A-8C are graphs summarizing the quality of compositions according to certain exemplary embodiments;

**[0031]** FIG. 9 is a graph showing results when additional elements are added to compositions according to certain example embodiments;

**[0032]** FIGS. 10A-10C show graphs summarizing impacts of additives being added to vanadium based frits according to certain example embodiments; and

**[0033]** FIGS. 11A-11C show graphs summarizing absorption in the visible and infrared wavelengths for vanadium based frits according to certain example embodiments.

#### DETAILED DESCRIPTION OF EXAMPLE EMBODIMENTS OF THE INVENTION

**[0034]** The following description is provided in relation to several example embodiments which may share common characteristics, features, etc. It is to be understood that one or

more features of any one embodiment may be combinable with one or more features of other embodiments. In addition, single features or a combination of features may constitute an additional embodiment(s).

**[0035]** Certain example embodiments may relate to glass units (e.g., VIG units) that include two glass substrates sealed with an improved seal, e.g., of or including a vanadium-based frit material. In certain example embodiments an improved seal may include the following materials: vanadium oxide, barium oxide, and zinc oxide. In addition, certain example embodiments may include one or more of the following compounds: Ta<sub>2</sub>O<sub>5</sub>, Ti<sub>2</sub>O<sub>3</sub>, SrCl<sub>2</sub>, GeO<sub>2</sub>, CuO, AgO, Nb<sub>2</sub>O<sub>5</sub>, B<sub>2</sub>O<sub>3</sub>, MgO, SiO<sub>2</sub>, TeO<sub>2</sub>, Ti<sub>2</sub>O<sub>3</sub>, Y<sub>2</sub>O<sub>3</sub>, SnF<sub>2</sub>, SnO<sub>2</sub>, CuCl, SnCl<sub>2</sub>, CeO<sub>2</sub>, AgCl, In<sub>2</sub>O<sub>3</sub>, SnO, SrO, MgO, and Al<sub>2</sub>O<sub>3</sub>.

**[0036]** FIG. 5 is cross-sectional view of a vacuum insulated glass unit according to certain example embodiments. VIG unit 500 may include first and second glass substrates 502a and 502b that are spaced apart and define a space therebetween. The glass substrates 502a and 502b may be connected via an improved seal 504, of or including a vanadium-based frit. Support pillars 506 may help maintain the first and second substrates 502a and 502b in substantially parallel spaced apart relation to one another. It will be appreciated that the

size of the particulates may be no larger than about 100 mesh. Once the glass is ground into a powder, it may be disposed between the substrates in step 608. In certain example embodiments, the powder may be dispensed as a paste with a binder. Heat may then be applied in step 610 to the glass substrate and the powder. In certain example embodiments, the heat may be between 300° C. and 400° C., or more preferably between 325° C. and 375° C. It will be appreciated that when heat of the above temperatures is applied to tempered glass that the tempered glass may lose a reduced amount of strength versus when heat of in excess of 350° C. is applied to the tempered glass. Thus, certain example embodiments preferably involve a frit melting temperature of less than 500° C., more preferably less than 425° C., and sometimes less than 350° C.

**[0039]** In certain example embodiments, the combined compounds include the following materials: vanadium oxide, barium oxide, and zinc oxide.

**[0040]** FIGS. 7A-7D show graphs summarizing properties of compositions according to certain example embodiments.

**[0041]** The table below corresponds to the data shown in FIG. 7A with those compositions with a melt quality of less than 4 (on a scale of 0 to 5) omitted from the table.

TABLE 1

Normalized Moles of Batch Composition								
V <sub>2</sub> O <sub>5</sub>	BaO	ZnO	BaO/ZnO	Bi <sub>2</sub> O <sub>3</sub>	B <sub>2</sub> O <sub>3</sub>	Tg(C.)	Tx1(C.)	Rating
43.66%	9.87%	46.47%	0.21			320	410	4
39.01%	13.25%	37.37%	.35	2.18%	8.20%	312	430	4
47.33%	12.96%	24.41%	0.53	9.95%	5.53%	305	380	4
50.24%	23.38%	21.39%	1.33			320	425	4
51.54%	26.26%	16.46%	1.60	5.75%		320	410	4.5

CTE of the improved seal 504 and the glass substrates 502a and 502b may substantially match one another. This may be advantageous in terms of reducing the likelihood of the glass cracking, etc. Although FIG. 5 is described in relation to a VIG unit, it will be appreciated that the improved seal 504, of or including a vanadium-based frit may be used in connection with other articles and/or arrangements including, for example, insulating glass (IG) units and/or other articles.

**[0037]** FIG. 6 is a flowchart illustrating a process for preparing a frit material to be used in making a vacuum insulated glass unit according to certain example embodiments. In step 600, base compounds are combined and disposed into an appropriate container (e.g., a heat resistant container such as, for example, a ceramic container). In step 602, the combined compound is melted. Preferably, the temperature to melt the combined material may be at least 1000° C. In certain exemplary embodiments, the combined compound is melted at 1000° C. for between 30 to 60 minutes. In certain exemplary embodiments, the combined compound is melted at 1100° C. for 60 minutes. In certain exemplary embodiments, the combined compound is melted at 1200° C. for 60 minutes. In certain exemplary embodiments, the melting temperature is a cycle that includes 500° C. for 15 minutes, 550° C. for 15 minutes, 600° C. for 15 minutes, and a ramp up to 1000° C. for 60 minutes.

**[0038]** After the combined compounds are melted, the material may be cooled in step 604, e.g., to form a glass sheet. After cooling, the glass may be crushed or ground into fine particulates in step 606. In certain example embodiments, the

**[0042]** The melts shown in FIG. 7A were applied to a microscope glass slide with a temperature of 375° C. applied for 15 minutes. FIG. 7B shows a graph that includes the crystallization temperature (first crystallization peak—Tx1—of the above table) of the above melts. According to certain exemplary embodiments, a preferred temperature for Tx1 may be between about 375° C. and 425° C., preferably about 400° C.

**[0043]** FIG. 7C shows the transition glass temperatures, Tg, compared the above melts. The graph showing exemplary data shows that Tg values between about 290 C and 335 C may be preferred for the above compositions.

**[0044]** FIG. 7D includes the above melts in a graph showing the melt quality versus the barium/zinc ratio.

**[0045]** FIGS. 8A-8C show graphs that summarize the quality of compositions according to certain exemplary embodiments. FIG. 8A summarizes the V<sub>2</sub>O<sub>5</sub> percentage used in certain exemplary compositions. FIG. 8B summarizes the BaO percentage used in certain exemplary compositions. FIG. 8C summarizes the ZnO percentage used in certain exemplary compositions. As shown in the illustrative graphs, a vanadium percentage of between about 51% and 53% may be preferable according to certain example embodiments.

**[0046]** Below, tables 2A-2C show exemplary compositions according to certain example embodiments. Additionally, examples 7-15 in the tables correspond to graphs 8A-8C. For the compositions shown in the below tables, BaCO<sub>3</sub> factor of 1.287027979 was used to convert to a BaO resulting compound.

TABLE 2A

Ex.	Weight Percentage			Weight Normal	Weights of Batch Composition for 25 grams			Normalized Weight Percentage		
	V <sub>2</sub> O <sub>5</sub>	BaO	ZnO		V <sub>2</sub> O <sub>5</sub>	BaO	ZnO	V <sub>2</sub> O <sub>5</sub>	BaO	ZnO
1	60	30	10	0.23	13.800	8.880	2.300	55.24	35.55	9.21
2	52.5	25	10	0.27	14.175	8.687	2.700	55.45	33.99	10.56
3	45	20	10	0.31	13.950	7.980	3.100	55.73	31.88	12.39
4	45	10	20	0.32	14.400	4.118	6.400	57.79	16.53	25.68
5	52.5	10	25	0.28	14.700	3.604	7.000	58.09	14.24	27.66
6	60	10	30	0.25	15.000	3.218	7.500	58.33	12.51	29.16
7	52.5	25	10	0.24	12.600	7.722	2.400	55.45	33.99	10.56
8	57.5	25	10	0.25	14.375	8.044	2.500	57.69	32.28	10.03
9	47.5	25	10	0.28	13.300	9.009	2.800	52.97	35.88	11.15
10	52.5	27.5	10	0.26	13.650	9.202	2.600	53.63	36.15	10.22
11	57.5	27.5	10	0.25	14.375	8.848	2.500	55.88	34.40	9.72
12	47.5	27.5	10	0.27	12.825	9.556	2.700	51.13	38.10	10.77
13	52.5	22.5	10	0.28	14.700	8.108	2.800	57.40	31.66	10.93
14	57.5	22.5	10	0.26	14.950	7.529	2.600	59.61	30.02	10.37
15	47.5	22.5	10	0.29	13.775	8.398	2.900	54.94	33.49	11.57

TABLE 2B

Ex.	Moles of Batch			Normalized Moles			Glass Type
	V <sub>2</sub> O <sub>5</sub>	BaO	ZnO	V <sub>2</sub> O <sub>5</sub>	BaO	ZnO	
1	0.3037	0.1801	0.1132	50.87%	30.17%	18.95%	amorphous
2	0.3049	0.1722	0.1298	50.24%	28.38%	21.39%	glassy
3	0.3064	0.1616	0.1522	49.41%	26.05%	24.54%	amorphous
4	0.3177	0.0838	0.3156	44.31%	11.68%	44.01%	amorphous
5	0.3194	0.0722	0.3400	43.66%	9.87%	46.47%	amorphous
6	0.3207	0.0634	0.3584	43.19%	8.54%	48.27%	amorphous
7	0.3049	0.1722	0.1298	50.24%	28.38%	21.39%	glassy
8	0.3172	0.1636	0.1233	52.51%	27.08%	20.41%	glassy
9	0.2912	0.1818	0.1370	47.74%	29.80%	22.46%	glassy
10	0.2949	0.1832	0.1255	48.85%	30.35%	20.80%	glassy
11	0.3073	0.1743	0.1194	51.12%	29.00%	19.87%	glassy
12	0.2811	0.1931	0.1323	46.35%	31.83%	21.81%	glassy
13	0.3156	0.1604	0.1344	51.70%	26.28%	22.01%	glassy
14	0.3278	0.1521	0.1274	53.97%	25.05%	20.98%	glassy
15	0.3021	0.1697	0.1421	49.20%	27.65%	23.15%	glassy

[0047] The rating shown in Table 2C is based off of depositing the ground composition on a microscope glass slide and heating the composition at about 375° C. for between 10 and 30 minutes.

TABLE 2C

Example	Tg (C. °)	Tx2 (C. °)	Tx2 (C. °)	Tx1 - Tg	Rating
1	280	330	540	50	0.0
2	320	425	525	105	4.0
3	280	430	550	150	0.0
4	280	320	365	40	0.0
5	320	410	560	90	4.0
6	285	425	560	140	0.0
7	315	390	530	75	4.5
8	295, 325	415	535	90	5.0
9	320	420	525	100	4.5
10	325	410	540	85	4.5
11	315	395	530	80	4.5
12	330	415	560	85	4.0
13	315	400	530	85	5.0
14	305	395	530	90	4.0
15	320	395	525	75	4.5

[0048] FIG. 9 shows a graph with results of adding additional elements (e.g., Bi<sub>2</sub>O<sub>3</sub> and B<sub>2</sub>O<sub>3</sub>) to a vanadium based fit. Corresponding data shown in FIG. 9 is also displayed below in Table 3.

TABLE 3

Ex.	V2O5	BaO	ZnO	Bi2O3	B2O3	Tg(C.)	Tx1(C.)	DSC Responses
1	65.39%	14.87%	12.46%	0.00%	7.28%	320	430	medium weak
2	60.96%	13.86%	11.61%	0.00%	13.57%	240	415	very weak
3	69.71%	15.85%	13.28%	1.16%	0.00%	315	405	strong peaks
4	64.69%	14.71%	12.32%	1.08%	7.20%	325	440	very weak
5	68.91%	15.67%	13.13%	2.29%	0.00%	320	410	medium weak
6	64.00%	14.56%	12.19%	2.13%	7.12%	320	425	very weak
7	59.74%	13.59%	11.38%	1.99%	13.30%	315	410	very weak
8	60.34%	13.72%	11.49%	1.00%	13.43%	315	400	very weak
9	70.53%	16.04%	13.43%	0.00%	0.00%	315	380	strong peaks



[0049] In certain example embodiments, a strong DSC response may correspond to a good remelt quality. In certain example embodiments, the addition of bismuth in concentrations of between about 0% and 3% may result in increased remelt flow quality.

[0050] In certain example embodiments, a frit that includes V<sub>2</sub>O<sub>5</sub>, BaO, and ZnO May further include one or more additives. In certain example embodiments, the additives may be between about 0.5% and 15% weight. According to certain example embodiments, the additives may be added to a base composition that includes between about 50% and 60% weight V<sub>2</sub>O<sub>5</sub>, 27% and 33% weight BaO, and 9% and 12% weight ZnO.

[0051] Below, Tables 4A-4D show results of including additives to the base composition of V<sub>2</sub>O<sub>5</sub>, BaO, and ZnO. Table 4D shows the melt quality on a scale of about 0 to 5 for each of the compositions. FIGS. 10A-10C show graphs corresponding to the data shown in the below tables. A BaCO<sub>3</sub> factor of 1.2870 was used to form the BaO used for the following examples.

TABLE 4C

Ex	Normalized Moles				Tg (C.)	(Tx1 (C.))	Tx2 (C.)	Tx1 - Tg
	V2O5	BaO	ZnO	Additive				
1	50.57%	25.71%	21.53%	2.20%	315	400	525	85
2	49.48%	25.16%	21.07%	4.30%	315	420	530	105
3	50.68%	25.76%	21.58%	1.99%	320	450		130
4	49.69%	25.26%	21.16%	3.90%	320	450	530	130
5	50.71%	25.78%	21.59%	1.92%	305	390	495	85
6	49.75%	25.29%	21.18%	3.77%	295	390	470	95
7	50.56%	25.70%	21.53%	2.21%	315	405	530	90
8	49.47%	25.15%	21.06%	4.32%	315	400	530	85
9	50.83%	25.84%	21.64%	1.68%	315	395	530	80
10	49.99%	25.41%	21.28%	3.31%	315	400	530	85
11	50.56%	25.71%	21.53%	2.20%	315	385	525	70
12	49.47%	25.15%	21.06%	4.31%	320	395	545	75
13	50.61%	25.73%	21.55%	2.12%	305	390	525	85
14	49.55%	25.19%	21.10%	4.16%	300	380		80
15	50.68%	25.76%	21.58%	1.98%	315	425	550	110
16	49.69%	25.26%	21.16%	3.89%	325	440	465	115

TABLE 4A

Ex	Weights (gm)					Normalized Weights				
	V2O5	BaO	ZnO	Additive Type	Amount	V2O5	BaO	ZnO	Additive	
1	52.5	22.5	10	TeO2	2	14.175	7.819	2.700	0.540	
2	52.5	22.5	10	TeO2	4	13.650	7.529	2.600	1.040	
3	52.5	22.5	10	Ta2O5	5	13.650	7.529	2.600	1.300	
4	52.5	22.5	10	Ta2O5	10	13.125	7.240	2.500	2.500	
5	52.5	22.5	10	Ti2O3	5	13.650	7.529	2.600	1.300	
6	52.5	22.5	10	Ti2O3	10	13.125	7.240	2.500	2.500	
7	52.5	22.5	10	SrCl2	2	14.175	7.819	2.700	0.540	
8	52.5	22.5	10	SrCl2	4	13.650	7.529	2.600	1.040	
9	52.5	22.5	10	GeO2	1	14.175	7.819	2.700	0.270	
10	52.5	22.5	10	GeO2	2	14.175	7.819	2.700	0.540	
11	52.5	22.5	10	CuO	1	14.175	7.819	2.700	0.270	
12	52.5	22.5	10	CuO	2	14.175	7.819	2.700	0.540	
13	52.5	22.5	10	AgO	1.5	14.175	7.819	2.700	0.405	
14	52.5	22.5	10	AgO	3	14.175	7.819	2.700	0.810	
15	52.5	22.5	10	Nb2O5	3	14.175	7.819	2.700	0.810	
16	52.5	22.5	10	Nb2O5	6	13.650	7.529	2.600	1.560	
17	52.5	22.5	10	B2O3	.8	14.175	7.819	2.700	0.216	
18	52.5	22.5	10	B2O3	1.6	14.175	7.819	2.700	0.432	

TABLE 4B

Ex	Normalized Weight Percentage				Moles of Batch Composition			
	V2O5	BaO	ZnO	Additive	V2O5	BaO	ZnO	Additive
1	56.17	30.99	10.70	2.14	0.309	0.157	0.131	0.013
2	55.00	30.34	10.48	4.19	0.302	0.154	0.129	0.026
3	54.43	30.02	10.37	5.18	0.299	0.152	0.127	0.012
4	51.75	28.54	9.86	9.86	0.285	0.145	0.121	0.022
5	54.43	30.02	10.37	5.18	0.299	0.152	0.127	0.011
6	51.75	28.54	9.86	9.86	0.285	0.145	0.121	0.022
7	56.17	30.99	10.70	2.14	0.309	0.157	0.131	0.013
8	55.00	30.34	10.48	4.19	0.302	0.154	0.129	0.026
9	56.78	31.32	10.82	1.08	0.312	0.159	0.133	0.010
10	56.17	30.99	10.70	2.14	0.309	0.157	0.131	0.020
11	56.78	31.32	10.82	1.08	0.312	0.159	0.133	0.014
12	56.17	30.99	10.70	2.14	0.309	0.157	0.131	0.027
13	56.48	31.15	10.76	1.61	0.311	0.158	0.132	0.013
14	55.58	30.66	10.59	3.18	0.306	0.155	0.130	0.026
15	55.58	30.66	10.59	3.18	0.306	0.155	0.130	0.012
16	53.87	29.71	10.26	6.16	0.296	0.151	0.126	0.023
17	56.91	31.39	10.84	0.87	0.313	0.159	0.133	0.012
18	56.42	31.12	10.75	1.72	0.310	0.158	0.132	0.025

TABLE 4C-continued

Ex	Normalized Moles				Tg (C.)	(Tx1 (C.))	Tx2 (C.)	Tx1 - Tg
	V2O5	BaO	ZnO	Additive				
17	50.66%	25.75%	21.57%	2.02%	315	410	540	95
18	49.66%	25.25%	21.14%	3.95%	320	405	545	85

TABLE 4D

Example	Melt Quality @ 375 C., 15 min	Melt Quality at 350 C., 15 min
1	5.0	4.0
2	4.5	4.0
3	4.5	2.0
4	5.0	2.0
5	4.5	4.5
6	5.0	5.0
7	5.5+	5.0
8	5.0	4.5
9	4.5	4.5

TABLE 4D-continued

Example	Melt Quality @ 375 C., 15 min	Melt Quality at 350 C., 15 min
10	4.5	4.5
11	4.5	2.0
12	4.0	2.0
13	4.0	5.0
14	3.5	4.0
15	4.5	2.0
16	5.0	2.0
17	4.0	4.5
18	3.5	2.0

**[0052]** In certain example embodiments, the molar composition of an additive to a base composition higher than is shown in tables 4A-4D. Table 5A shows additives with an increased additive amount (on a % mole basis). The base composition used with the additive amount may be based on, for example, the base composition shown in Row 1 of Tables 4A-4D. The additives shown in Table 5, in the selected quantities displayed, may improve melt quality when compared to the above base composition. A melt type of Glassy indicates that a “button” of the compound melted onto a glass plate, forming a homogenous glassy structure. Sinter indicates that the compound (in a powder form) fused together, but remained in a powder form.

TABLE 5

Example	Additive Type	Amount	Melt Type (350 C. for 20 minutes)	Adhesion to glass substrate.
1	CuCl	4.00%	Glassy	No Stick
2	SnCl <sub>2</sub>	3.99%	Glassy	No Stick
3	SnCl <sub>2</sub>	5.99%	Glassy, Slight Flow	Slight stick
4	SiO <sub>2</sub>	6.02%	More Glassy	No Stick
5	Al <sub>2</sub> O <sub>3</sub>	6.00%	Glassy	No Stick
6	CeO <sub>2</sub>	4.00%	Sinter	No Stick
7	TeO <sub>2</sub>	3.99%	Glassy	Slight stick
8	TeO <sub>2</sub>	6.01%	Glassy	Slight stick
9	Tl <sub>2</sub> O <sub>3</sub>	3.99%	Glassy, Slight Flow	No Stick
10	Tl <sub>2</sub> O <sub>3</sub>	6.01%	Glassy, Slight Flow	No Stick

**[0053]** Accordingly, in certain example embodiments, additives of a relatively increased amount (e.g., versus those shown in FIG. 4) may be added to a base composition. In certain example embodiments, the additives may include, for example, CuCl, SnCl<sub>2</sub>, SiO<sub>2</sub>, Al<sub>2</sub>O<sub>3</sub>, and TeO<sub>2</sub>. It will be appreciated that toxic nature of thallium oxide (Tl<sub>2</sub>O<sub>3</sub>) may preclude its use in certain instances.

**[0054]** In certain example embodiments, two or more additives may be included in a base compound. Table 6 shows the results of adding two additives to an exemplary base composition. Table 6 includes example melts at 375 and 350. Additionally, 13 mm buttons of the exemplary compounds were tested on a glass plate. The structural strength of the resulting exemplary compound are also shown in the far right column.

TABLE 6

Ex	Add 1	Add 2	Amount 1 (Mole %)	Amount 2 (Mole %)	Melt Quality (375 C. 15-20 Min)	Melt Quality (350 C. 15-20 Min)	13 mm Button 350 C. 20 Min	Strength
1	TeO <sub>2</sub>	Al <sub>2</sub> O <sub>3</sub>	3.01	3.01	4.5	5.5	glassy	Fractures
2	TeO <sub>2</sub>	Al <sub>2</sub> O <sub>3</sub>	2.99	5.01	5	4	glassy	Fractures
3	TeO <sub>2</sub>	Al <sub>2</sub> O <sub>3</sub>	4.02	3.01	6	5.5	glassy	Fractures
4	TeO <sub>2</sub>	Al <sub>2</sub> O <sub>3</sub>	3.99	5.00	5	4.5	glassy	Fractures
5	TeO <sub>2</sub>	Al <sub>2</sub> O <sub>3</sub>	5.01	2.99	4.5	4.5	glassy	Fractures
6	TeO <sub>2</sub>	Al <sub>2</sub> O <sub>3</sub>	5.00	5.00	5	4.5	glassy	Fractures
7	TeO <sub>2</sub>	SiO <sub>2</sub>	3.01	3.00	5	5.5	glassy	Fractures
8	TeO <sub>2</sub>	SiO <sub>2</sub>	2.99	5.02	5	4.5	glassy	Fractures
9	TeO <sub>2</sub>	SiO <sub>2</sub>	4.00	2.99	5	4	glassy	Fractures
10	TeO <sub>2</sub>	SiO <sub>2</sub>	3.99	4.99	5	4.5	Less glassy	Fractures
11	TeO <sub>2</sub>	SiO <sub>2</sub>	5.00	2.99	4.5	4.5	Less glassy	Hard
12	TeO <sub>2</sub>	SiO <sub>2</sub>	5.00	4.99	4.5	4.5	Less glassy	Hard
13	SnCl <sub>2</sub>	Al <sub>2</sub> O <sub>3</sub>	3.01	3.01	5	6	more glassy	Hard
14	SnCl <sub>2</sub>	Al <sub>2</sub> O <sub>3</sub>	3.00	5.01	5	5.5	glassy	Hard
15	SnCl <sub>2</sub>	Al <sub>2</sub> O <sub>3</sub>	4.01	3.01	4.5	6	glassy	Hard
16	SnCl <sub>2</sub>	Al <sub>2</sub> O <sub>3</sub>	4.00	4.99	5.5	6	glassy	Hard
17	SnCl <sub>2</sub>	Al <sub>2</sub> O <sub>3</sub>	5.00	2.99	5.5	5.5	glassy	Fractures
18	SnCl <sub>2</sub>	Al <sub>2</sub> O <sub>3</sub>	5.00	5.00	5.5	5.5	more glassy	Hard
19	SnCl <sub>2</sub>	SiO <sub>2</sub>	3.00	3.00	4.5	4.5	glassy	Hard
20	SnCl <sub>2</sub>	SiO <sub>2</sub>	3.00	4.99	5	6	glassy	Hard
21	SnCl <sub>2</sub>	SiO <sub>2</sub>	4.00	2.99	6	6	glassy	Fractures
22	SnCl <sub>2</sub>	SiO <sub>2</sub>	4.01	4.99	5.5	5.5	glassy	Fractures
23	SnCl <sub>2</sub>	SiO <sub>2</sub>	5.00	2.99	5	5.5	glassy	Hard
24	SnCl <sub>2</sub>	SiO <sub>2</sub>	5.00	4.99	5.5	5.5	glassy	Fractures
25	Al <sub>2</sub> O <sub>3</sub>	SiO <sub>2</sub>	3.01	3.00	4.5	4	less glassy	Hard
26	Al <sub>2</sub> O <sub>3</sub>	SiO <sub>2</sub>	2.99	4.99	5	5.5	less glassy	Hard

TABLE 6-continued

Ex	Add 1	Add 2	Amount 1 (Mole %)	Amount 2 (Mole %)	Melt Quality (375 C. 15-20 Min)	Melt Quality (350 C. 15-20 Min)	13 mm Button 350 C. 20 Min	Strength
27	Al <sub>2</sub> O <sub>3</sub>	SiO <sub>2</sub>	4.00	2.99	4.5	4.5	less glassy	Hard
28	Al <sub>2</sub> O <sub>3</sub>	SiO <sub>2</sub>	4.00	4.99	5	4.5	less glassy	Hard
29	Al <sub>2</sub> O <sub>3</sub>	SiO <sub>2</sub>	5.01	2.99	5	4.5	less glassy	Hard
30	Al <sub>2</sub> O <sub>3</sub>	SiO <sub>2</sub>	5.01	4.99	4	2	less glassy	Hard

**[0055]** Accordingly, certain example may include two additives similar to those found in examples 3, 16, and 21 as shown in Table 6 (e.g., TeO<sub>2</sub> with SiO<sub>2</sub>, SnCl<sub>2</sub> with Al<sub>2</sub>O<sub>3</sub>, and SnCl<sub>2</sub> with SiO<sub>2</sub>). In certain example embodiments, the addition of two or more additives may have beneficial results on an exemplary base composition. For example the addition of SiO<sub>2</sub> to another additive may increase the strength of the overall frit. Alternatively, or in addition, TeO<sub>2</sub> combined with other additives may increase the melt flow and glass wetting qualities of the frit when compared to a base frit.

**[0056]** In certain example embodiments, the combination of SnCl<sub>2</sub> with SiO<sub>2</sub> and/or Al<sub>2</sub>O<sub>3</sub> may result in an increase in structural strength for the resulting frit material.

**[0057]** In certain example embodiments, one or more additives may be added to a base composition where the amount is between 1% and 10% by weight or between about 1% and 6% normalized moles for a batch. In certain example embodiments, additives may be added in a smaller amount, for example between about 0.1% and 1% by weight. In certain example embodiments a batch for a base composition (in grams) may include V<sub>2</sub>O<sub>5</sub> at 52.5, BaO at 22.5, ZnO at 10. In certain example embodiments, additives added to the above base composition may include: 1) TeO<sub>2</sub> at 3.85 gm and Al<sub>2</sub>O<sub>3</sub> at 1.84 gm; 2) SnCl<sub>2</sub> at 4.65 gm and Al<sub>2</sub>O<sub>3</sub> at 3.12 gm; 3) SnCl<sub>2</sub> at 4.55 gm and SiO<sub>2</sub> at 1.08 gm. Correspondingly, the additives may then have a normalized weight percentage of: 1) TeO<sub>2</sub> at 1.00 and Al<sub>2</sub>O<sub>3</sub> at 0.48; 2) SnCl<sub>2</sub> at 1.21 and Al<sub>2</sub>O<sub>3</sub> at 0.81; 3) SnCl<sub>2</sub> at 1.18 and SiO<sub>2</sub> at 0.28. These examples may correspond to examples 3, 16, and 21 in the above table 6.

**[0058]** FIGS. 11A-11C show graphs illustrating absorption in the visible and infrared wavelengths for vanadium based frits according to certain example embodiments. As shown in the graphs, example vanadium based frits may have absorption of at least 90% across a substantial breath of the visible and IR spectrum. In certain example embodiments the absorption may be about 95%. As discussed in co-pending application Ser. No. 13/\_\_\_\_\_, entitled "IMPROVED FRIT MATERIALS AND/OR METHOD OF MAKING VACUUM INSULATING GLASS UNITS INCLUDING THE SAME" (atty. dkt. no. 3691-2307), the entire contents of which are incorporated herein by reference, frit materials with high visible/IR absorption may be advantageous.

**[0059]** FIG. 11A shows the absorption properties of a vanadium based frit with TeO<sub>2</sub> and Al<sub>2</sub>O<sub>3</sub> used as additives (e.g., Ex. 3 of Table 6). FIG. 11B shows the absorption properties of a vanadium based frit with SnCl<sub>2</sub> and Al<sub>2</sub>O<sub>3</sub> used as additives (e.g., Ex. 16 of Table 6). FIG. 11C shows the absorption

properties of a vanadium based frit with SnCl<sub>2</sub> and SiO<sub>2</sub> used as additives (e.g., Ex. 21 of Table 6).

**[0060]** In certain example embodiments, the application of IR energy to a frit material may be based on a heating profile where the IR energy applied to the frit varies over time. Exemplary heating profiles may be found in co-pending application Ser. No. 13/\_\_\_\_\_, (atty. dkt. no. 3691-2307), the entire contents of which are incorporated herein by reference.

**[0061]** In certain example embodiments, a base composition may be augmented by 3 or 4 additives. For example, a batch for a base composition (in grams) may include V<sub>2</sub>O<sub>5</sub> at 52.5, BaO at 22.5, ZnO at 10. Accordingly, three and/or more additives from among TeO<sub>2</sub>, SnCl<sub>2</sub>, Al<sub>2</sub>O<sub>3</sub>, and SiO<sub>2</sub> may be selected to augment the base composition. The ranges (in grams) for the additives may vary between 0 to 7.5 grams per additive. Thus, on a normalized molar percentage the above additives may be included at between 0% and 6%. Thus, the normalized molar percentage of a base composition may be V<sub>2</sub>O<sub>5</sub> at between about 43% and 50%, BaO between about 22% and 26%, ZnO between about 18% and 22%. In certain example embodiments, additives (on a normalized molar basis) of TeO<sub>2</sub> at around 2%, SnCl<sub>2</sub> around 2%, Al<sub>2</sub>O<sub>3</sub> around 2%, and SiO<sub>2</sub> around 4% may be added to the base composition.

**[0062]** The techniques, compositions, etc disclosed herein may be used other methods and/or systems for forming a VIG unit. For example, a vanadium based frit may be used to form an edge seal of a VIG unit. Systems, apparatuses, and/or methods used for creating a VIG unit may be described in co-pending application 13/\_\_\_\_\_, entitled "LOCALIZED HEATING TECHNIQUES INCORPORATING TUNABLE INFRARED ELEMENT(S) FOR VACUUM INSULATING GLASS UNITS, AND/OR APPARATUSES FOR THE SAME" (atty. dkt. no 3691-2108), the entire contents of which are hereby incorporated by reference.

**[0063]** It will be appreciated by those skilled in the art that CTE adjustments may be carried out on the overall frit material (e.g., the compound) for the wetting and bonding properties of the frit to cooperate with an underlying substrate (e.g., a glass substrate).

**[0064]** It will be appreciated that one or more metal oxide, chloride, and/or fluoride additives may be used as additives in different embodiments of this invention. Furthermore, in certain example implementations, the metal oxide, chloride, and/or fluoride additives may be stoichiometric or sub-stoichiometric.

**[0065]** As used herein, the terms "on," "supported by," and the like should not be interpreted to mean that two elements

are directly adjacent to one another unless explicitly stated. In other words, a first layer may be said to be “on” or “supported by” a second layer, even if there are one or more layers there between.

[0066] While the invention has been described in connection with what is presently considered to be the most practical and preferred embodiment, it is to be understood that the invention is not to be limited to the disclosed embodiment, but on the contrary, is intended to cover various modifications and equivalent arrangements included within the spirit and scope of the appended claims.

1-14. (canceled)

15. A method of making a frit material, the method comprising:

providing a composition to a holder, the composition comprising:

Ingredient	Wt. %
vanadium oxide	~50-60%,
barium oxide	~27-33%, and
zinc oxide	~9-12%;

and

at least one additive that is selected from the group consisting of: Ta<sub>2</sub>O<sub>5</sub>, Ti<sub>2</sub>O<sub>3</sub>, SrCl<sub>2</sub>, GeO<sub>2</sub>, CuO, AgO, Nb<sub>2</sub>O<sub>5</sub>, B<sub>2</sub>O<sub>3</sub>, MgO, SiO<sub>2</sub>, Tl<sub>2</sub>O<sub>3</sub>, Y<sub>2</sub>O<sub>3</sub>, SnF<sub>2</sub>, SnO<sub>2</sub>, CuCl, SnCl<sub>2</sub>, CeO<sub>2</sub>, AgCl, In<sub>2</sub>O<sub>3</sub>, SnO, SrO, and Al<sub>2</sub>O<sub>3</sub>;

melting the composition;

cooling the melted composition and/or allowing the melted composition to cool so as to form an intermediate glass article;

grinding the intermediate glass article in making the frit material.

16. The method of claim 15, wherein the at least one additive comprises Nb<sub>2</sub>O<sub>5</sub> and constitutes between about 2-8 wt. %.

17. The method of claim 15, wherein the at least one additive comprises SrCl<sub>2</sub> and constitutes between about 2-6 wt. %.

18. The method of claim 15, wherein the at least one additive comprises Ti<sub>2</sub>O<sub>3</sub> and constitutes between about 4.5-10 wt. %.

19. The method of claim 15, wherein the at least one additive comprises Ta<sub>2</sub>O<sub>5</sub> and constitutes between about 4.5-10 wt. %.

20. The method of claim 15, wherein the at least one additive comprises AgO and constitutes between about 1.5-3.5 wt. %.

21. The method of claim 15, wherein the at least one additive comprises CuO of between about 1% and 2.5% weight.

22. The method of claim 15, wherein the at least one additive further comprises SnCl<sub>2</sub> and constitutes between about 1-8 wt. %.

23. The method of claim 22, wherein the at least one additive further comprises Al<sub>2</sub>O<sub>3</sub> and constitutes between about 1-8 wt. %.

24. The method of claim 22, wherein the at least one additive further comprises SiO<sub>2</sub> of between about 0.5-5 wt. %.

25. The method of claim 15, wherein the at least one additive further comprises Al<sub>2</sub>O<sub>3</sub> and constitutes between about 1-8 wt. %.

26. The method of claim 25, wherein the composition further comprises TeO<sub>2</sub> of between about 1-8 wt. %.

27. The method of claim 15, wherein the frit material has a melting temperature less than or equal to about 375 degrees C.

28. The method of claim 27, wherein the frit material has a melting temperature less than or equal to about 350 degrees C.

29. The method of claim 15, wherein the base composition is melted at a temperature of at least about 1000 degrees C.

30. A method of making a vacuum insulated glass (VIG) unit, the method comprising:

providing first and second glass substrates in substantially parallel, spaced apart relation to one another;

sealing together the first and second glass substrates using a frit material, a gap being defined between the first and second substrates,

wherein the sealing is performed by melting the frit material at a temperature of no more than about 375 degrees C., the frit material having been formed from a base composition including:

Ingredient	Wt. %
vanadium oxide	~50-60%,
barium oxide	~27-33%, and
zinc oxide	~9-12%;

and

at least one oxide-, chloride-, or fluoride-based additive.

31. A frit material having a composition comprising:

Ingredient	Wt. %
vanadium oxide	~50-60%,
barium oxide	~27-33%, and
zinc oxide	~9-12%;

and

at least a first and second additive selected from the group consisting of: SiO<sub>2</sub>, SnCl<sub>2</sub>, Al<sub>2</sub>O<sub>3</sub>, and TeO<sub>2</sub>.

32. The frit material of claim 31, further comprising a third additive, different from the first and second additive, selected from the group consisting of: SiO<sub>2</sub>, SnCl<sub>2</sub>, Al<sub>2</sub>O<sub>3</sub>, and TeO<sub>2</sub>.

33. The frit material of claim 33, further comprising a fourth additive, different from the first, second additive, and third additive, selected from the group consisting of: SiO<sub>2</sub>, SnCl<sub>2</sub>, Al<sub>2</sub>O<sub>3</sub>, and TeO<sub>2</sub>.

34. The frit material of claim 31, wherein the first and the second additive comprise between about 0.5% and 5% by weight% of the frit material.

35. The frit material of claim 31, wherein the frit material has a melting temperature less than or equal to about 400 degrees C.

\* \* \* \* \*