

FORM P8(PCT)

(Lodge in Duplicate)

REPUBLIC OF SOUTH AFRICA

PATENTS ACT, 1978

PUBLICATION PARTICULARS AND ABSTRACT

[Section 32(3)(a) - Regulation 22(1)(g) and 31]

21	01	Official Application No.s	2004/0515			DrG Ref.: 52526	
22	Lodging date:		2004-01-23				
43	Acceptance date:		08-04-2005				
51	International Classification:		B27L				
		Not for publication.	WIPO				
		Classified by:					
71	Full name(s) of applicant(s): Key Knife Inc						
72	Full name(s) of inventor(s) SCHUH, Loren, R. SIMONSEN, Tobias, L.						
Earliest priority claimed		33	Country	31	Number	32	Date
			US		09/918,895		30 July 2001
54	Title of invention KNIFE AND APPARATUS FOR CLAMPING A KNIFE						
57	Abstract See next page.						
Number of sheets		38					

ADDRESS FOR SERVICE:
DR GERNTOLTZ INC
PATENT AND TRADE MARK ATTORNEYS
P O BOX 8 CAPE TOWN 8000 SOUTH AFRICA
30 UNION ROAD MILNERTON 7441
TELEPHONE: +27 21 551 2650
TELEFAX: +27 21 551 2960



WO 03/011541 A1

(54) Title: KNIFE AND APPARATUS FOR CLAMPING A KNIFE

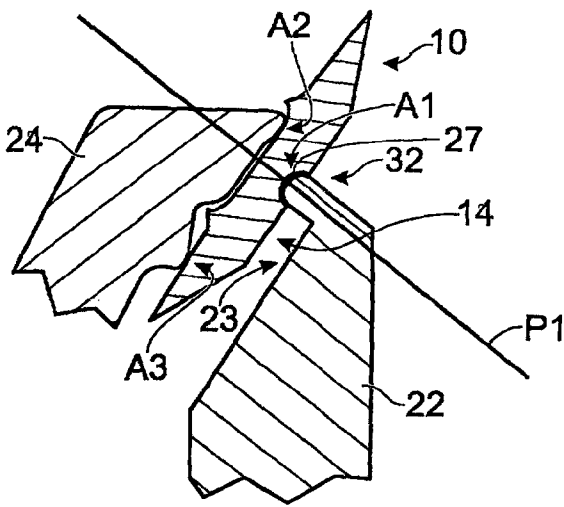

(57) Abstract: A knife (10) and apparatus for clamping the knife. The knife has front (12) and back sides (14) that, preferably, both include interlocking features adapted for interlocking engagement with corresponding inner and outer clamping members, to prevent slippage of the knife from the clamping members in orientations wherein the knife rests thereon in the chipping apparatus when the knife is unclamped. Preferably, the interlocking feature of the back side of the knife includes a semi-cylindrical groove, and the interlocking feature of the front side of the knife includes two spaced-apart deflector ridges (18A, 18B). Preferably the interlocking feature of the outer clamping member is a projection having a semi-cylindrical tip portion (27) wherein the semi-cylindrical shape is preferably half-cylindrical, and wherein the projection (32) extends from an inner surface (23) of the outer clamping member sufficiently far that most of the back side of the knife does not make contact therewith.

KNIFE AND APPARATUS FOR CLAMPING A KNIFE

The subject matter of the present application is related to that of the assignee's companion application entitled METHOD AND APPARATUS FOR CLAMPING A KNIFE, of Thomas Charles Hinchliff, incorporated by reference herein in its entirety.

5 Background of the Invention

The present invention relates to a knife and apparatus for clamping a knife in a wood chipper, such as a disc, drum or conical head chipper for use in the commercial processing of logs.

In wood chipping apparatus used in the forest products industry, a rotating
10 member is provided for receiving replaceable knives for cutting chips from the log. Each knife is typically clamped to the rotating member between an outer clamping member and an inner clamping member or counterknife, wherein the knife and counterknife together form a surface against which the log is forced to remove chips from the log. The chips themselves have commercial value, and their removal shapes
15 the log into lumber and finishes its surface. The clamping members essentially form a cassette for the knife, although the entire cassette is often referred to in the trade as a knife. Herein, the term "knife" is used to refer to the blade that is clamped between the outer and inner clamping members.

The spacing between the outer and inner clamping members is adjustable for
20 loading the knife into the apparatus, or unloading the knife from the apparatus, such as for replacing the knife or turning the knife end-to-end to position an alternative knife

edge in the chipper. A preferred mechanism for adjusting the spacing between an outer clamping member an inner clamping member is described in U.S. Patent No. 5,979,522, also incorporated herein by reference in its entirety.

As one example of a wood chipping apparatus, a chipper disc typically spins in a vertical plane. A number of identical knives are spaced around the periphery of the disc. The knives are elongate, and their elongate axes are oriented along radial lines passing approximately through the center of the disc, the axis of each knife becoming horizontal at respective 9:00 and 3:00 positions of the disc. When unclamped, the knives are typically unrestrained from sliding along these radial lines, so it is preferable to unclamp the knives when they are at least approximately in one of these two level positions.

A shroud is typically provided that covers the disc to retain chips and to shield personnel, the shroud including a closeable opening in a predetermined angular position of rotation of the disc, to provide access to a knife that has become aligned therewith. The position of the opening is selected so that the heavy and sharp knife will not slip forwardly out of the apparatus when it is unclamped; however, even so, the knife remains free to slip backwardly into the apparatus and still presents some risk of injury or damage. Such considerations are important as well to other types of wood chippers, such as the drum and conical head chippers.

Accordingly, there is a need for a knife and apparatus for clamping the knife in a chipping apparatus that provides for more safely and securely preventing movement of an unclamped knife along a line of slippage extending into and out of the apparatus.

Summary of the Invention

A knife and apparatus for clamping the knife according to the present invention solves the aforementioned problem and meets the aforementioned need by providing an elongate knife having front and back sides co-terminating in a cutting edge, and outer and
5 inner clamping members for clamping the knife therebetween adapted to receive, respectively, the back and front side of the knife. The back side of the knife and the outer clamping member have mutually interlocking features to prevent slippage of the knife from the outer clamping member in orientations wherein the knife rests thereon in the chipping apparatus when the knife is unclamped.

10 The front side of the knife and the inner clamping member preferably also have mutually interlocking features to prevent slippage of the knife from the inner clamping member in orientations wherein the knife rests thereon in the chipping apparatus when the knife is unclamped.

In one aspect of the invention, the interlocking feature of the back side of the
15 knife includes at least one semi-cylindrical groove, wherein the knife is preferably bilaterally symmetric about a plane parallel to the elongate axis of the knife and wherein the semi-cylindrical shape is preferably half-cylindrical.

In another aspect of the invention, the interlocking feature of the outer clamping
20 member is a projection having a semi-cylindrical tip portion wherein the semi-cylindrical shape is preferably half-cylindrical.

In yet another aspect of the invention, the projection of the outer clamping member extends from an inner surface thereof sufficiently far that most of the back side of the knife does not make contact therewith, to better control the point of application of clamping force.

5 Where the tip portion of the projection is semi-cylindrical, a degree of rotation of the knife about the projection is permitted which facilitates installation of the knife and which accommodates a greater degree of dimensional variance in the mating parts, further facilitating installation of the knife as well as reducing manufacturing costs.

10 Therefore, it is a principal object of the present invention to provide a novel and improved knife and apparatus for clamping the knife.

 It is another object of the present invention to provide a knife and apparatus for clamping the knife that provides for more safely holding the knife in position in a chipping apparatus when the knife is unclamped therein.

15 It is yet another object of the present invention to provide a knife and apparatus for clamping the knife that provides for more securely holding the knife in position in the chipping apparatus when the knife is unclamped therein.

 It is still another object of the present invention to provide a knife and apparatus for clamping the knife that facilitates installation and removal of the knife from the chipping apparatus.

It is a further object of the present invention to provide a knife and apparatus for clamping the knife that provides for reduced manufacturing costs of the knife and clamping members.

It is still a further object of the present invention to provide a knife and apparatus
5 for clamping the knife that provides for increased control over the application of clamping force to the knife.

The foregoing and other objects, features and advantages of the present invention will be more readily understood upon consideration of the following detailed description of the invention, taken in conjunction with the following drawings.

10 Brief Description of the Drawings

Figure 1A is a pictorial view of a knife according to the present invention, showing a front side of the knife in perspective.

Figure 1B is a pictorial view of the knife of Figure 1 showing a back side of the knife in perspective.

15 Figure 2A is an elevation of a disc chipper including a plurality of knives such as that shown in Figures 1A and 1B.

Figure 2B is a cross-section of the disc chipper of Figure 2A, taken through a knife that is in the 3:00 position of the disc along a line **2B-2B**, showing the knife clamped in the disc chipper.

Figure 3A is a cross-section of the disc chipper of Figure 2B, taken through another knife that is in the 9:00 position of the disc along a line 3A-3A thereof, showing the knife unclamped in the disc chipper.

Figure 3B is a cross-section of the disc chipper and knife of Figure 2B, showing the knife in the 3:00 position unclamped in the disc chipper.

Figure 4A is a partial cross-section, corresponding to the cross-section of Figure 3B in the 3:00 position, of a knife and outer clamping member according to the present invention.

Figure 4B is a partial cross-section of the knife and outer clamping member of Figure 4A, showing the knife clamped between the outer clamping member and an inner clamping member.

Detailed Description of a Preferred Embodiment

Referring to Figures 1A and 1B, a preferred knife 10 is shown modified according to the present invention. The knife without modification has been widely available as manufactured by Key Knife, Inc., of Tualatin, Oregon, and is described in detail in Schmatjen, U.S. Patent No. 5,819,826, herein incorporated by reference in its entirety. The knife 10 may be employed in any wood chipping apparatus, such as a disc, drum or conical head wood chipper. The knife has an elongate-axis "L", a front side 12 and a back side 14.



John L. Spicer
Patent Attorney

WO 03/011541

PCT/US02/22576

The front side 12 of the knife 10 includes spaced deflector ridges 18a and 18b that project therefrom. Each of the deflector ridges is characterized by a single linear edge 13a and 13b respectively. The deflector ridges define a channel 34 having a channel surface 34a. The channel 34 is effectively a recess in the front side of the knife, which may be provided in other configurations, such as a keyway. The deflector ridges also define two lower knife-edge-joining portions 38a and 38b that terminate in respective cutting edges 16a and 16b.

The back side 14 of the knife 10 includes a clamp-facing surface portion 14a that is substantially planar and parallel to the channel surface 34a, and two upper knife-edge-joining portions 35a and 35b that slope from opposite edges of the clamp-facing surface portion to the cutting edges 16a and 16b. The knife 10 is typically provided so that the lower knife-edge-joining portion 38a lies in the same plane as the lower knife-edge-joining portion 38b (and the channel surface 34a); however, these faces can be ground or otherwise provided according to the aforementioned companion application entitled METHOD AND APPARATUS FOR CLAMPING A KNIFE so that the lower knife-edge-joining portions are not coplanar.

As mentioned previously, the above features are described in the '826 Patent. While the invention is believed to provide maximum advantage when used in connection with the preferred knife, the invention will provide an advantage when used with other prior art knives as well, such as knives that do not have all of the aforementioned features, or knives which include additional features.

Referring to Figure 2A, a disc chipper 20 is shown employing a plurality of the knives 10. While a disc chipper is used herein to illustrate use of particular embodiments of the invention, the principles of the invention apply equally to other chipping apparatus including that employing a drum or a "conical" head, and application of those principles to alternative configurations of chipping apparatus will be readily apparent to those of ordinary skill in the art.

The knives are elongate, meaning herein that they have a shape in a cross-sectional plane that is maintained for some distance along an axis "A" that is perpendicular to the plane. For use in a disc chipper, the length of the knives along the axis "A" is typically large in comparison to the cross-sectional dimensions of the knives; however, the length of the knives may be small in comparison to these dimensions, such as where many discs are combined to form a drum in a drum chipping apparatus. In the disc chipper, the elongate axes "A" extend radially, approximately from the center of the disc. The disc spins in a vertical plane in the direction of the arrow, with an exposed cutting edge 16a of each knife being visible.

Figure 2B shows a cross-section of the disc chipper 20 taken through a particular knife 10a that is in the 3:00 position of the disc as it is shown in Figure 2A. The knife is shown clamped in the disc chipper between outer and inner clamping members 22a and 24a respectively, so that the disc is ready for use for cutting wood. The inner clamping member is often referred to as a "counterknife."

An insert 21 is received in a corresponding pocket in the disc chipper. The insert supports the outer and inner clamping members as well as means for adjusting the spacing between the clamping members for clamping and unclamping the knife. For clamping the knife as shown, at least a portion of the channel surface 34a (Figure 1A) is abuttably received by the inner clamping member 24a, and the clamp-facing surface portion 14a of the back side 14 of the knife (Figure 1B) is at least disposed proximate to (Figure 4B) and may be abuttably received by an inner surface 23 (Figure 3A) of the outer clamping member 22a.

Preferably, the outer clamping member 22a is fixedly disposed with respect to the insert 21, and a threaded adjustment member 26a is received in a corresponding threaded aperture through the outer clamping member which permits translating the adjustment member in the directions indicated by the arrows, for adjustably pivoting the inner clamping member 24a about a bearing surface 33 that is provided as part of the insert 21. Alternatively, the position of the inner clamping member may be fixed and the outer clamping member may be adapted to be adjustably spaced apart therefrom, and either or both clamping members may be adjustably movable by any desired means without departing from the principles of the invention.

Turning to Figure 3A, a cross-section similar to that of Figure 2B shows another knife 10b (see also Figure 2A) which is in the 9:00 position of the disc. By contrast to the knife 10a in Figure 2B, the knife 10b is unclamped in the disc chipper. The inner clamping member 24b for the knife 10b has been pivoted about the surface 33 to provide

a spacing from the outer clamping member 22b that is sufficient for removing the knife from, or installing the same knife or a different knife, between the clamping members.

When the clamping members 22b and 24b are separated, the knife 10b in the 9:00 position rests on the inner clamping member 24b under the influence of gravity.

5 More particularly, one of the deflector ridges 18a is disposed outside a toe 19 of the inner clamping member 24b at one end of the toe, the other end of the toe being defined by a recess 28 shaped to receive the other of the other deflector ridge 18b. The channel 34 as bounded by the deflector ridges defines a recess that, along with the relatively projecting toe of the inner clamping member, provide interlocking means which
10 cooperate to hold the knife 10b to the inner clamping member 24b against the influence of gravity when the knife is unclamped in the 9:00 position of the disc. Alternatively, a keyway may be provided in the knife for receiving the toe. However, if the knife is dislodged, it may fall outwardly from the disc chipper along a line of slippage "B," posing a substantial risk of injury or damage.

15 Interlocking the knife to the inner clamping member also provides for locating and positioning the knife ("indexing") so that it is accurately disposed for cutting when the clamping members are adjusted to clamp the knife therebetween.

Turning to Figure 3B, a cross-section similar to that shown in Figure 2B illustrates the knife 10a unclamped in the disc chipper in the 3:00 position of the disc. The inner
20 clamping member 24a has been pivoted about the surface 33 to provide a spacing from the outer clamping member 22a that is sufficient for removing the knife from, or

installing the same knife or a different knife, between the clamping members. When the clamping members 22a and 24a are separated, such as by use of the adjustment mechanism 26a, the knife 10a in the 3:00 position of the disc rests on the outer clamping member 24a under the influence of gravity as shown. It may be noted that the clamping members need not be maximally separated for this result to occur, the clamping members becoming separated at the point that the clamping force they exert on the knife is reduced to zero.

The knife 10a in the 3:00 position cannot be interlocked with the inner clamping member 24, hence the safety and indexing features provided by the deflector ridges of the knife and the recess 28 of the inner clamping member are lost in this position. Thence, the unclamped knife in the 3:00 position of the disc will ordinarily slip backwardly into the apparatus along the line of slippage "B," against interior portions of the outer and inner clamping members. While the risk of injury to personnel is much reduced as compared to that posed by slippage of the knife in the 9:00 position, such slippage may cause damage to the knife or the apparatus, and may make removal of the knife somewhat difficult. Moreover, installation of the knife is also difficult, and indexing the knife into proper position while clamping the knife is very difficult.

With additional reference to Figure 1A, to improve the safety and security of holding the unclamped knife in the 3:00 position of the disc as well as to provide for indexing of the knife, the knife and outer clamping members are provided with interlocking features to prevent slippage of the knife into or out of the apparatus along the

axis "B" (Figure 3B) when the knife is unclamped, providing an outstanding advantage over the prior art.

In a preferred embodiment of the invention, the otherwise substantially planar clamp-facing surface portion 14a of the back side 14 of the knife includes a recess 30 that is particularly a groove, and the outer clamping member 22 includes a complementary elongate projection 32 adapted to fit into the groove, where persons of ordinary skill will immediately recognize the equivalence of providing the knife with a projection and the outer clamping member 22 with a complementary and corresponding groove. According to the invention, the interlocking features of the knife and outer clamping member may be any interlockingly cooperating male or female structures that permit removing the knife from the outer clamping member while preventing the aforementioned slippage.

Preferably, the interlocking features interlock or retain one another in the direction or plane of slippage "B" while providing for free movement of the knife in one or both perpendicular directions. As mentioned, the recess 30 and projection 32 are preferably elongate, and at least a portion of each is preferably semi-circular as seen in a cross-section perpendicular to the elongate axis "L" (Figure 1A), to provide surfaces that are semi-cylindrical. Most preferably and particularly as shown, the shape of the recess 30 and the shape of a distal tip 27 (best seen in Figure 4B) of the projection in cross-section are half-circular, to provide surfaces that are half-cylindrical.

These shapes are believed to be especially advantageous for easing installation of the knife, by permitting the knife to pivot on the projection about the elongate axis of the

knife which facilitates manipulating the knife into position, and by accommodating greater manufacturing tolerances, which further reduces the effort required to place the knife into position as well as manufacturing costs.

Referring to Figures 4A and 4B, the preferred form of the interlocking features provides that the projection 32 extends far enough from the inner surface 23 of the outer clamping member so that a “three-point” contact is provided for clamping the knife, wherein the projection 32 provides one of the points of contact. In Figure 4A, the inner clamping member 24 has been moved away from the outer clamping member 22, and the knife 10 is held loosely by the projection 32. In Figure 4B, the clamping member 24 has been pivoted to receive the front side 12 of the knife and clamp the knife to the projection 32 of the clamping member 22, wherein the projection 32 has sides 32a and 32b that are substantially perpendicular to the inner surface 23 of the clamping member 22, terminating in a tip 27 having the semi-circular cross-section, and extending far enough from the surface 23 so that the knife can rotate (compare Figures 4A and 4B) about its elongate axis at the tip 27, and so that the back side of the knife is not otherwise in contact with the surface 23 when the knife is clamped (Figure 4B).

Permitting a minimal but significant (“substantial”) degree of rotation of the knife on the projection facilitates installation of the knife while not defeating the purpose of the projection to interlock with the recess 30 to prevent slippage. The semi-cylindrical surface of the projection may extend over an arc that is greater or less than a half-cylindrical 180 degrees, while the semi-cylindrical surface of the recess 30 should have an arc that is about 180 degrees or less, to prevent the recess 30 from

pinching or capturing the projection, which would decrease the efficacy of the connection between the parts and make both removal and installation of the knife difficult.

As mentioned, providing that most of the back side of the knife does not
5 contact the surface 23 when the knife is clamped provides for a "three-point" contact, i.e., a point of contact "A1" at the tip 27 falls between, with respect to a line "P1," two other points of contact "A2" and "A3," so that contact is not being made, and force is not being transmitted, between most of the back side of the knife 14 and the clamping member 22. This provides a means for applying the clamping force that is consistent
10 in spite of manufacturing variations in the dimensions of the parts.

The semi-cylindrical shapes for the projection and recess 30 are also believed to decrease manufacturing cost by rendering the capability to index the knife accurately to the outer clamping member less sensitive to manufacturing tolerances in these features.

15 While in the preferred embodiment these features extend over the entire length of the knife (determined in the direction of the axis "L"), this is not essential, and it may provide some additional indexing capability to limit the lateral extent of the interlocking features, so that the knife is retained laterally (into and out of the plane of Figure 3A) as well as with respect to slippage in the direction or plane "B." However,
20 the knife may be freely moved away from the inner clamping member 22a along the perpendicular direction "C," for changing the knife.

Preferably, the interlocking feature of the knife is located so that the knife is or remains bilaterally symmetric with respect a plane "P" (Figure 1B) that is parallel to

the elongate axis of the knife, so that the knife may be turned end-to-end in a perpendicular plane, rather than rotated about the elongate axis, such as is required in Valo, U.S. Patent No. 4,271,882 or Svensson, U.S. Patent No. 4,047,670, for example, to obtain a fresh cutting edge from the knife. In view of the sharp edges of the knives and their great weight, it is believed that the former operation is easier to perform than the latter as it can be performed without touching the cutting edges, without holding both sides of the knife, and without requiring a rotation of the wrist.

It should be noted that to provide such symmetry does not require a single interlocking feature that is centered on or in the back side 14 of the knife such as shown in Figure 1B. For example, bilateral symmetry with respect to the plane "P" may be obtained by providing an interlocking feature of the knife consisting of two, or any even number of recesses 30 that are symmetrically disposed with respect to the plane, either alone or in combination with a recess 30 that is centrally disposed in the plane. This provides the option of applying clamping force to the back side of the knife off its center.

To permit the aforementioned pivoting of the knife about the projection, it is preferable that only one projection is provided that is adapted to be received in just one of the one or more recesses 30 that are provided. However, providing this advantage is not essential, and additional projections may be provided without departing from the principles of the invention.

Other forms and shapes of the interlocking features may be provided also without departing from the principles of the invention. For example, the one or more projections could be formed as pins and the one or more recesses as complementary

apertures, holes or cavities providing for free movement along the axis "C" even though sliding the knife laterally is not permitted without first separating the pins from the holes by movement of the knife along the axis "C." A similar effect is obtained, as mentioned above, by forming the preferred groove so that it does not extend the
5 entire length of the knife.

Provision of the recesses 30 (Figure 3A) and projections 32 makes it particularly advantageous to access the knife for changing or other purposes at the 3:00 position of the disc. According to the invention, then, the opening in the shroud is preferably situated at this position. Moreover, providing the interlocking features of
10 the knife and outer clamping member in combination with the interlocking features of the knife and counterknife provides for safely holding the knife in the apparatus as well as indexing the knife to the apparatus in either or both the 9:00 and 3:00 positions of the disc, resulting in outstanding flexibility.

It is to be recognized that, while a specific method and apparatus for clamping
15 a knife has been shown and described as preferred, other configurations could be utilized, in addition to configurations already mentioned, without departing from the principles of the invention.

The terms and expressions which have been employed in the foregoing specification are used therein as terms of description and not of limitation, and there is
20 no intention in the use of such terms and expressions to exclude equivalents of the features shown and described or portions thereof, it being recognized that the scope of the invention is defined and limited only by the claims which follow.

WO 03/011541

PCT/US02/22576

Claims:

1. A knife for a wood chipping apparatus, comprising opposed front and back sides co-terminating in two spaced apart cutting edges lying in a plane, said front side including, in correspondence with said cutting edges, a respective two spaced apart deflector ridges, each deflector ridge terminating in a single linear edge, parallel to the respective said cutting edge, and maximally spaced from said plane, said back side including a semi-cylindrical interlocking feature.

2. The knife of claim 1, wherein said semi-cylindrical interlocking feature is a groove.

3. A clamp for clamping a knife in a wood chipping apparatus, the knife having a back side terminating in at least one cutting edge, the back side having a recess therein, the clamp comprising an inner surface for disposition proximate the back side of the knife and a projection depending therefrom for engaging the recess, said projection terminating in a semi-cylindrical tip portion of said projection.

4. The clamp of claim 3, wherein said tip portion is convex.

5. A wood chipping apparatus, comprising:

a knife having a back side terminating in at least one cutting edge, said back side having a first semi-cylindrical interlocking feature therein; and

an inner clamping member comprising a projection terminating in a second semi-cylindrical interlocking feature that is complementary in form to said first interlocking feature for engagement therewith, for clamping said knife in the wood chipping apparatus, said projection extending from said inner

WO 03/011541

PCT/US02/22576

clamping member so as to permit rotation of said knife relative thereto during said engagement.

6. The apparatus of claim 5, wherein said first interlocking feature is a recess, and wherein said second interlocking feature is convexly curved.

7. The apparatus of claim 5, wherein said knife has a front side, wherein said front and back sides co-terminate in two spaced apart cutting edges lying in a plane, said front side including, in correspondence with said cutting edges, a respective two spaced apart and similar projecting interlocking features that project a maximum distance from said plane.

8. The apparatus of claim 7, wherein said projecting interlocking features include deflector ridges, each deflector ridge terminating in a single linear edge, parallel to the respective said cutting edge, and maximally spaced from said plane.

9. The apparatus of claim 8, further comprising an outer clamping member adapted to interlockingly receive at least one of said deflector ridges during said engagement.

10. The apparatus of claim 8, wherein said first interlocking feature is a recess, and wherein said second interlocking feature is convex.

11. The apparatus of claim 5, wherein said knife has a front side, said front and back sides co-terminating in said cutting edge, said front side including a projecting interlocking feature, the apparatus further comprising an outer clamping member adapted to interlockingly receive said projecting interlocking feature.

12. A wood chipping apparatus, comprising:

a knife having a back side terminating in at least one cutting edge, said back side having a first semi-cylindrical interlocking feature therein; and

WO 03/011541

PCT/US02/22576

a clamp for clamping said knife by applying a clamping force thereto, said clamp comprising a projection terminating in a second semi-cylindrical interlocking feature that is complementary in form to said first interlocking feature for engagement therewith, substantially the entirety of said clamping force being transmitted through said engagement.

13. The apparatus of claim 12, wherein said first interlocking feature is a recess, and wherein said second interlocking feature is convexly curved.

14. The apparatus of claim 12, wherein said knife has a front side, wherein said front and back sides co-terminate in two spaced apart cutting edges lying in a plane, said front side including, in correspondence with said cutting edges, a respective two spaced apart and similar projecting interlocking features that project a maximum distance from said plane.

15. The apparatus of claim 14, wherein said projecting interlocking features include deflector ridges, each deflector ridge terminating in a single linear edge, parallel to the respective said cutting edge, and maximally spaced from said plane.

16. The apparatus of claim 15, further comprising an outer clamping member adapted to interlockingly receive at least one of said deflector ridges during said engagement.

17. The apparatus of claim 15, wherein said first interlocking feature is a recess, and wherein said second interlocking feature is convex.

18. The apparatus of claim 12, wherein said knife has a front side, said front and back sides co-terminating in said cutting edge, said front side including a projecting interlocking feature, the apparatus further comprising an outer clamping member adapted to interlockingly receive said projecting interlocking feature.

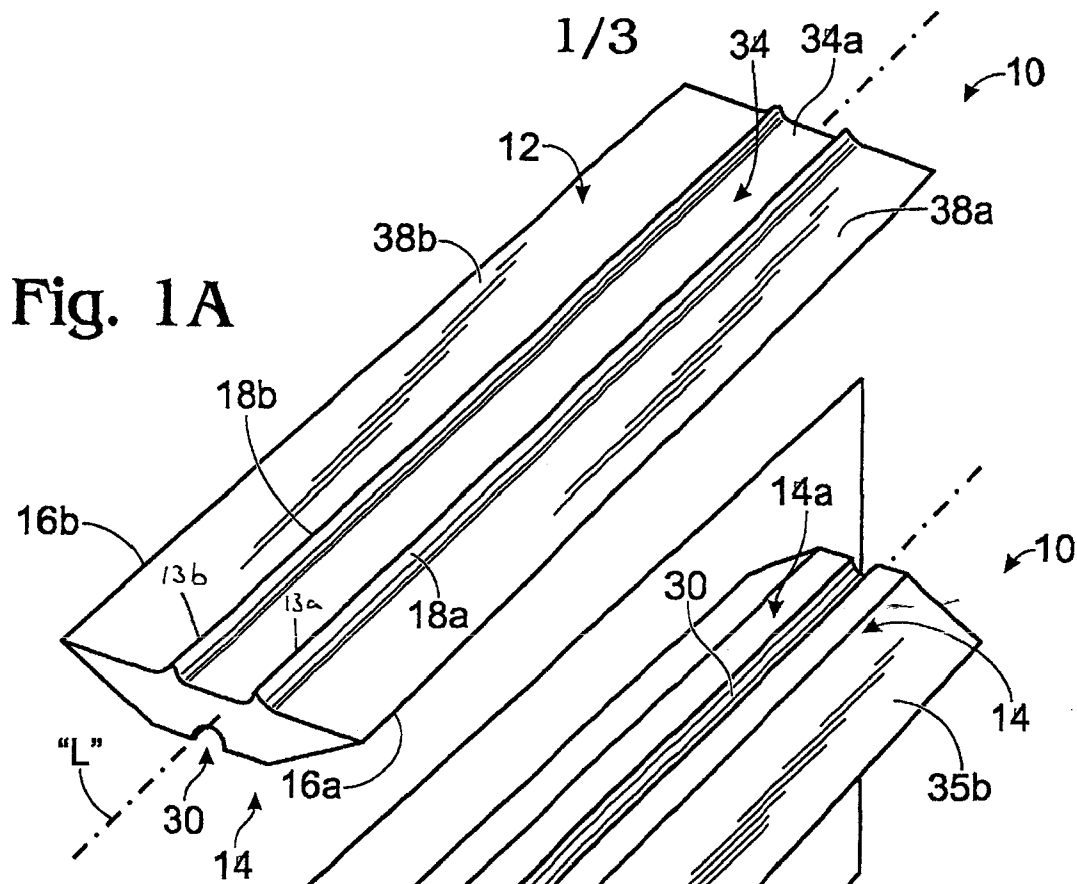

Fig. 1A

Fig. 1B

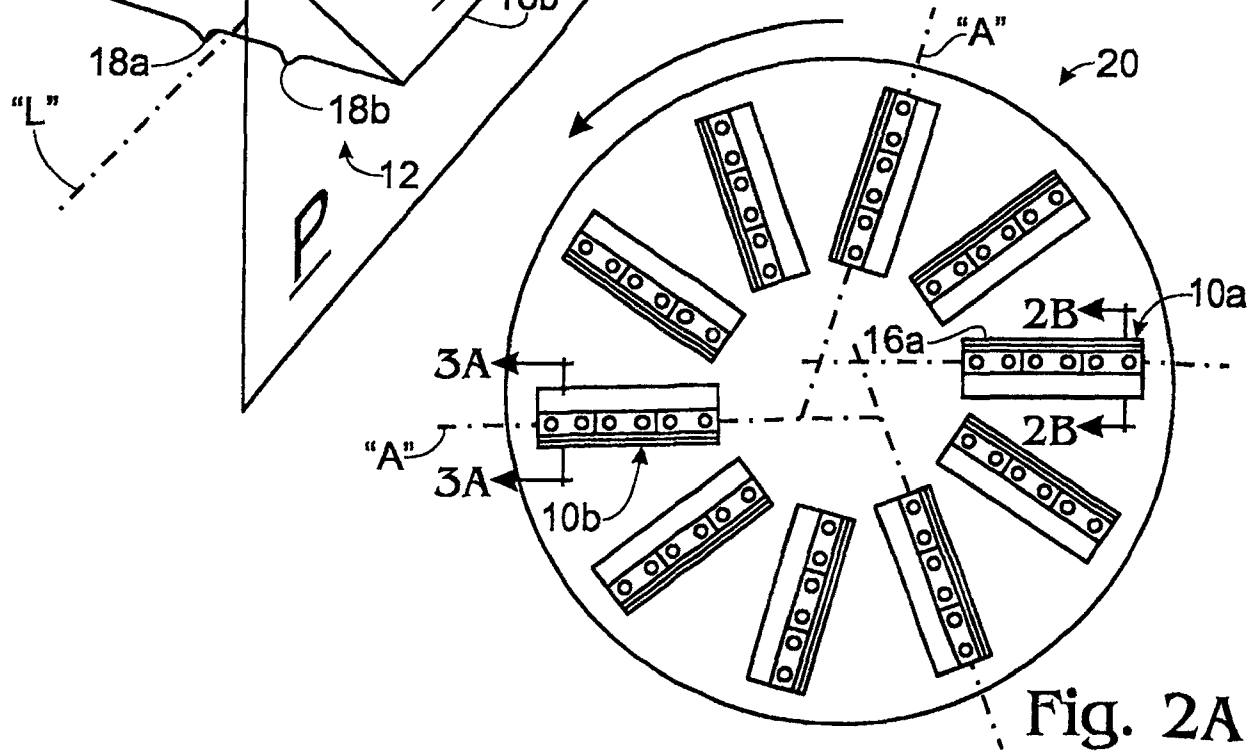

Fig. 2A

Fig. 3A

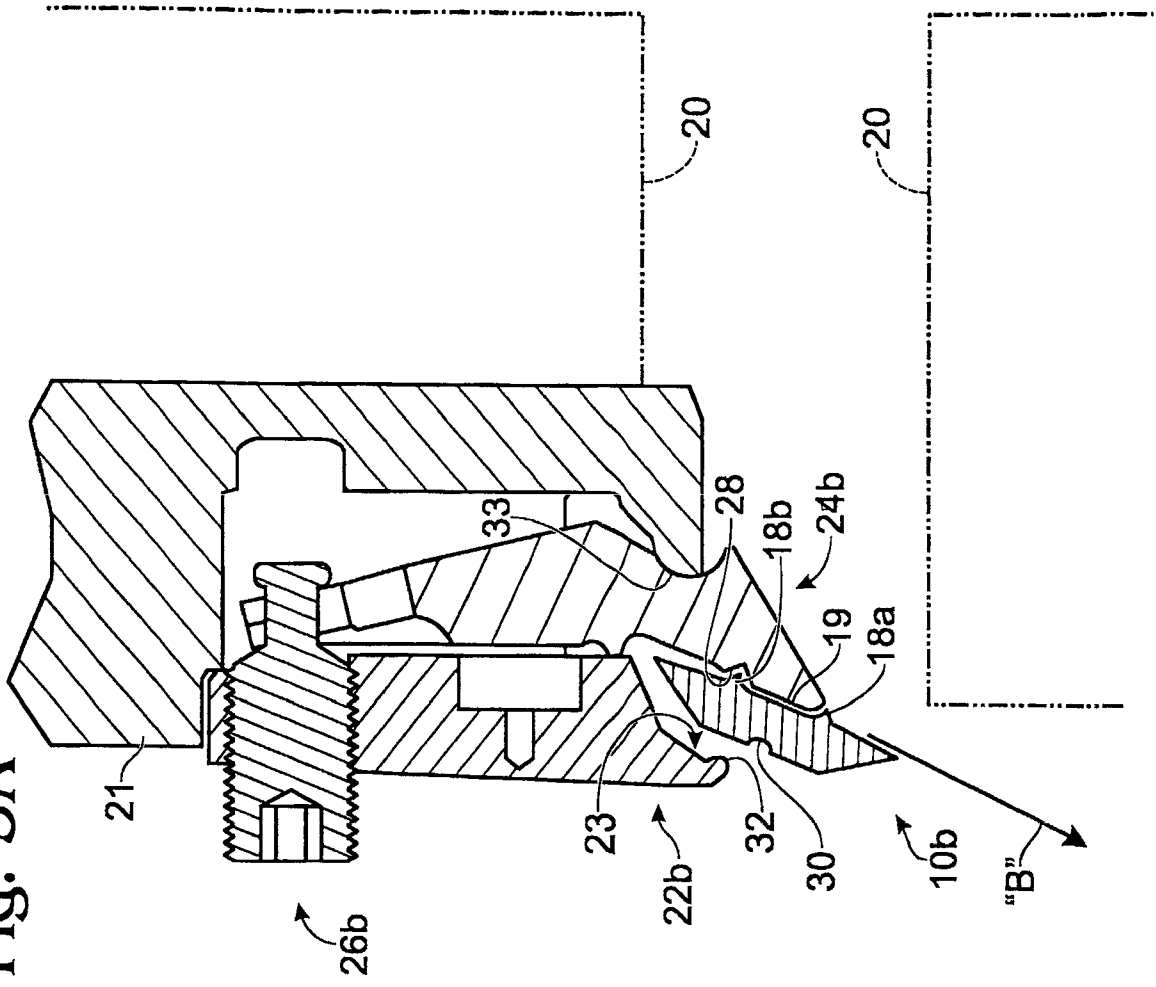

Fig. 2B

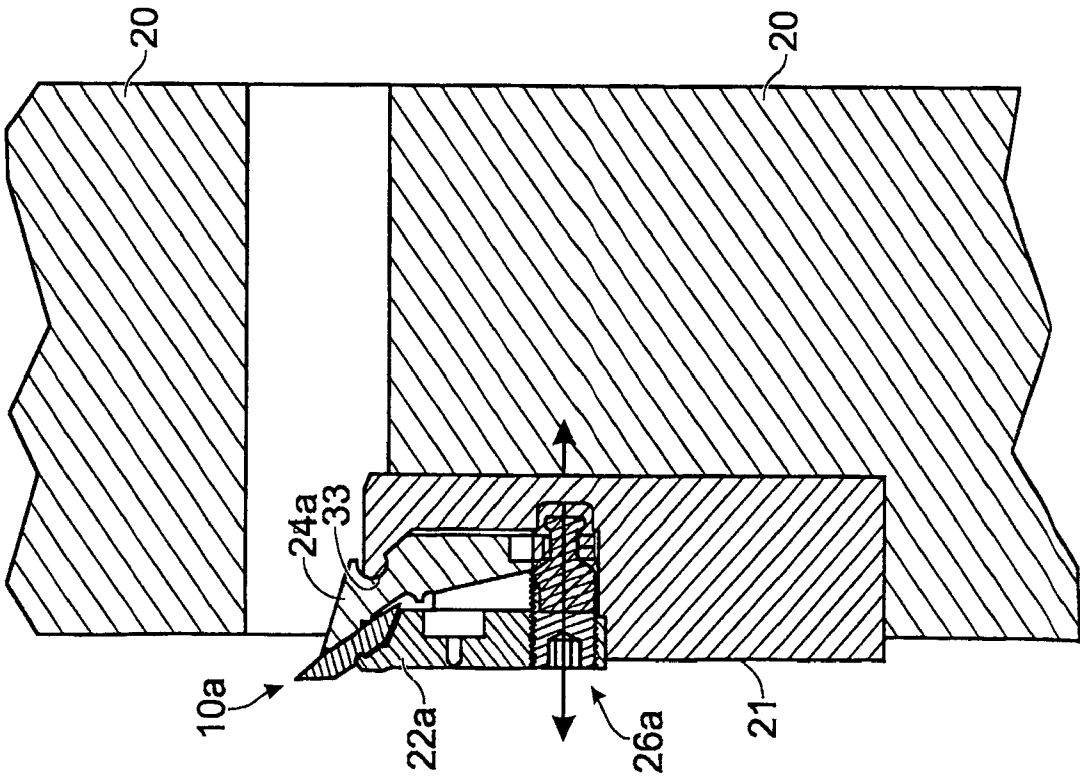

Fig. 3B

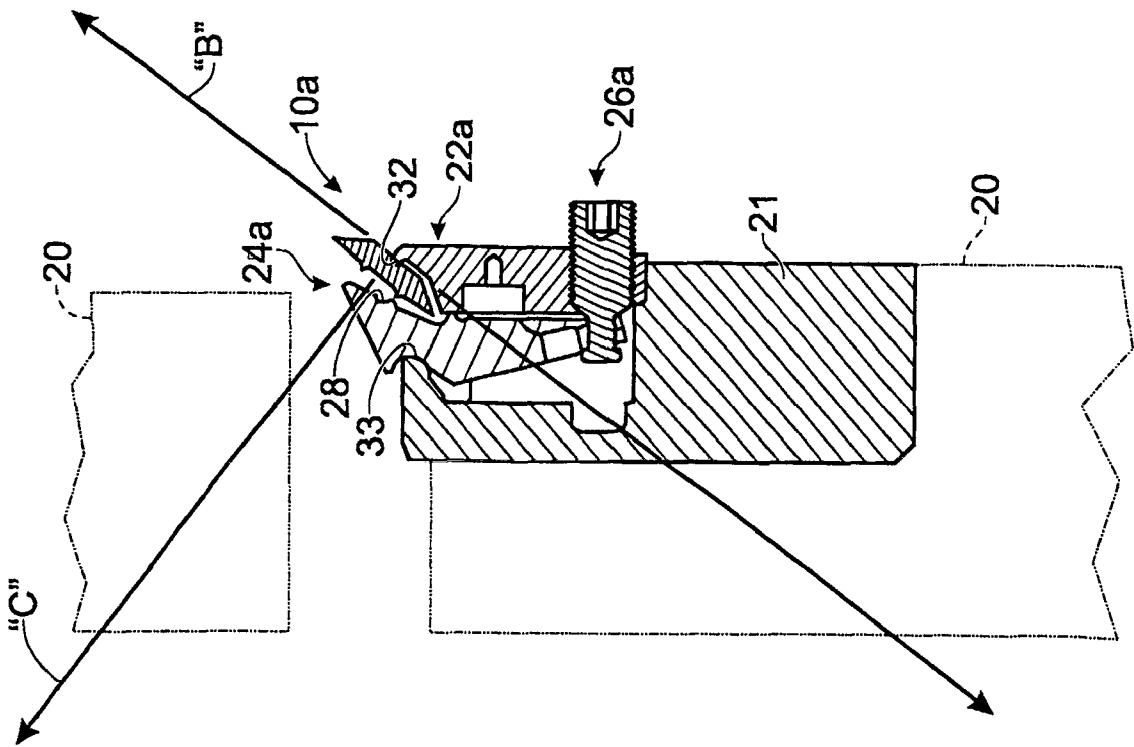

Fig. 4A

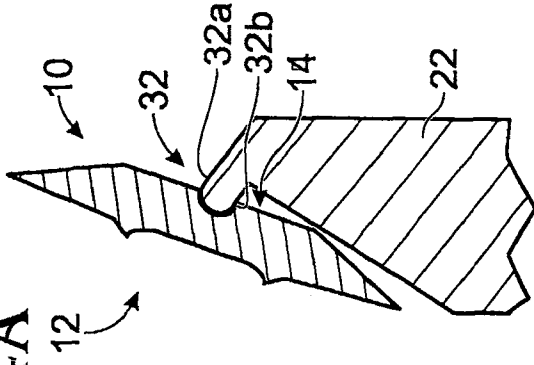

Fig. 4B

