



(19) **United States**

(12) **Patent Application Publication**  
**Paradis**

(10) **Pub. No.: US 2016/0242992 A1**

(43) **Pub. Date: Aug. 25, 2016**

(54) **SYSTEM FOR DYNAMICALLY STABILIZING THE CHEST WALL AFTER INJURY, FRACTURE, OR OPERATIVE PROCEDURES**

(52) **U.S. Cl.**  
CPC ..... *A61H 9/0078* (2013.01); *A61B 5/08* (2013.01); *A61B 5/1135* (2013.01); *A61B 5/4836* (2013.01)

(71) Applicant: **Norman A. Paradis**, Putney, VT (US)

(72) Inventor: **Norman A. Paradis**, Putney, VT (US)

(21) Appl. No.: **15/051,383**

(22) Filed: **Feb. 23, 2016**

**Related U.S. Application Data**

(60) Provisional application No. 62/119,588, filed on Feb. 23, 2015.

**Publication Classification**

(51) **Int. Cl.**  
*A61H 9/00* (2006.01)  
*A61B 5/113* (2006.01)  
*A61B 5/00* (2006.01)  
*A61B 5/08* (2006.01)

(57) **ABSTRACT**

A method for treating chest wall injuries, including rib fractures, flail chest injuries or surgical incisions. The method comprising creating a localized airtight compartment external to the chest wall and fully covering the area of injury, varying the pressure within the compartment, and providing dynamic real-time counter forces that act reciprocal to the intrathoracic pressure changes that occur during ventilation. In a preferred embodiment, the apparatus has the capability of sensing the patient's chest wall motion created by ventilation, a pressure control component capable of varying the pressure within the airtight compartment such that it opposes pressure changes within the chest. Said apparatus would be particularly useful in preventing the paradoxical movement of flail chest injuries. The method would also lessen pain experienced by patients with thoracic injuries such as rib fractures and post operative suffering.

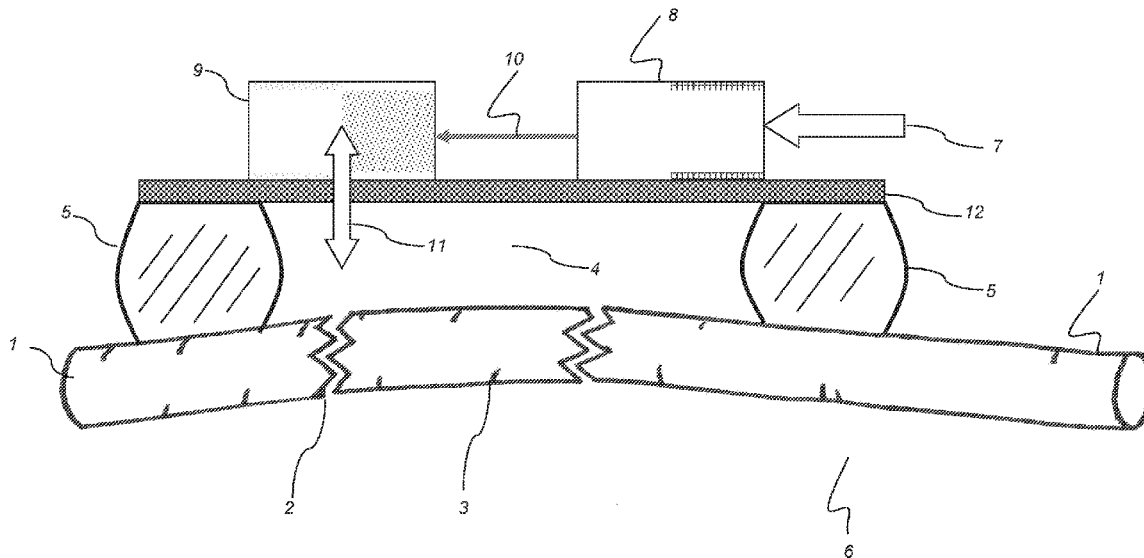

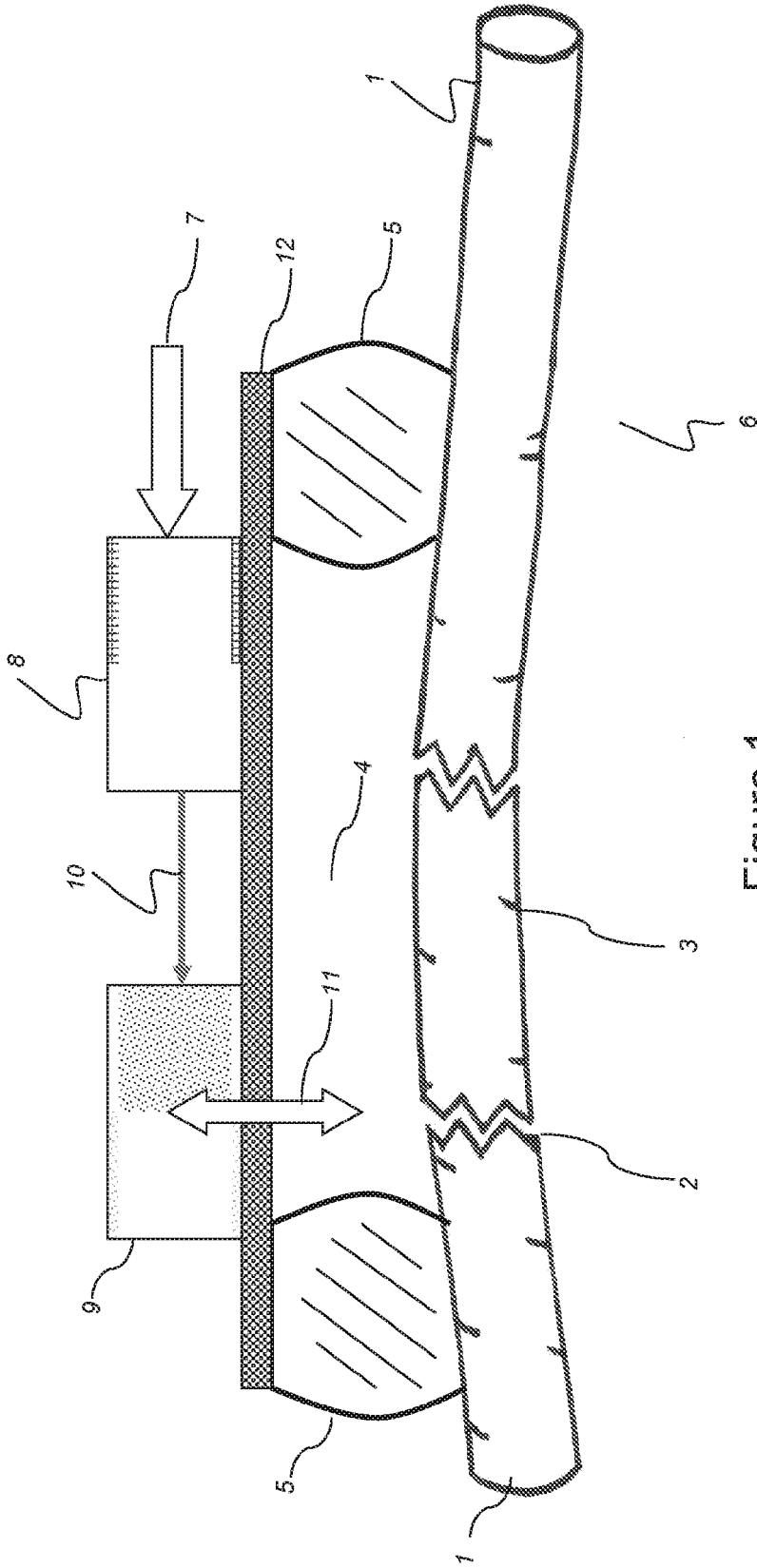

Figure 1

**SYSTEM FOR DYNAMICALLY STABILIZING  
THE CHEST WALL AFTER INJURY,  
FRACTURE, OR OPERATIVE PROCEDURES**

FIELD OF THE INVENTION

**[0001]** The invention disclosed herein relates in general to the fields of devices used in medicine, surgery and emergency trauma therapy, and in particular to methods for stabilizing the chest wall after injuries such as rib fractures, flail chest, or surgery.

BACKGROUND OF THE INVENTION

**[0002]** The need to create negative intrathoracic pressures so as to allow ventilation has necessitated that the human chest be a rigid structure. This is achieved via the ribs, the spine and connecting cartilage, all of which form components of the thorax. The rigid and semi-rigid component of the thorax may be damaged as a result of injury or operative surgical procedure. Rib fractures may involve one or more than one ribs. Surgical entry into the chest may cause fracture or injury to the ribs or sternum. During ventilation, intrathoracic pressure is alternated between positive and negative pressure so as to achieve air movement. After injury to the chest wall, this phasic change in intrathoracic pressure is associated with pain. This pain may cause splinting and interference with normal ventilation.

**[0003]** Flail chest injury in particular is among the most serious traumatic injuries of the thorax. In Flail chest injury a sufficient number of ribs are broken in multiple locations such that a portion of the chest wall is no long structurally attached to the thorax. It is among the most clinically challenging of chest wall injuries not involving actual penetration. (Ciraulo et al. 466-70)

**[0004]** Flail chest injury is significant in particular because pathologic movement of the free segment may result in additional injury. The ends of the fractured ribs may lacerate intercostal vessels and lung tissue. Injury to the underlying lung may cause and exacerbate pulmonary contusion. Movement of the free segment is very painful to the patient.

**[0005]** Movement of the free segment may be paradoxical to the remainder of the chest wall with ventilation. When the patient inhales and exhales, the uninjured chest wall moves outward and inward respectively. The free segment in flail chest injury may move reciprocally, moving in with inspiration and out with expiration. This paradoxical movement may be particularly painful and will act to exacerbate visceral injuries.

**[0006]** Currently, Flail chest injury is definitively stabilized surgically in the operating room. There is currently no effective noninvasive method or device to treat, or even stabilize, flail chest injury. (Dehghan et al. 462-68)

**[0007]** Rib fractures are among the most common chest wall injuries and are associated with significant morbidity and pain. Cardiac surgery is frequently undertaken via an artificial cut through the sternum called a median sternotomy. Both rib fractures and median sternotomy are painful for patients and this pain is difficult to treat. They are also associated with significant morbidity as the pain associated with each of the components of the ventilatory cycle cause the patient to limit chest wall motion which interferes with pulmonary toilet. Similarly, this pain interferes with the normal sighing required for pulmonary toilet.

**[0008]** The changes in intrathoracic pressure created during inspiration exacerbate the pain of rib fractures, median sternotomy, and flail chest injuries. In the case of flail chest injury the changes in intrathoracic pressure associated with the ventilatory cycle exacerbate movement of the free segment and contribute to further injury.

**[0009]** It is now possible to measure ventilation noninvasively using techniques such as impedance, and plethysmography, among others. Such measurement makes possible dynamic treatment of chest wall injuries in a manner that the device acts to provide force reciprocal to intrathoracic changes in pressure.

PRIOR ART

**[0010]** There is no prior art teaching the local dynamic stabilization of the chest wall by varying of the extra thoracic air pressure. The vast majority of previous devices and methods are limited to direct mechanical stabilization such as is achieved with screw, clamps or direct pressure.

**[0011]** The prior art fails to teach localized treatment of chest wall injuries by creation of an airtight extrathoracic compartment and application of dynamic positive and negative pneumatic counter forces. Additionally, the prior art fails to teach real-time sensing of ventilation as an input to the device controller.

**[0012]** Shaffer (U.S. Pat. No. 8,034,011 B2) teaches dynamic stabilization of only the anterior chest by mechanical pressure applied to the lateral surfaces. He does not teach: localized treatment, creation of an airtight extrathoracic compartment, or application of dynamic positive and negative pneumatic counterforce. Of particular significance, Schaffer teaches away from treatment of conditions other than injury to the anterior chest

**[0013]** Kochamba (WO1999047085 A1) teaches fixation of tissue and broken bones via a pneumatic bladder. He does not teach: creation of an airtight extrathoracic compartment, sensing of ventilation, or application of dynamic positive and negative pneumatic counterforce.

**[0014]** Others (CN 103431934 A) teach an adjustable air column for fixation or protection of thoracic injury. They do not teach: sensing of ventilation, or application of positive and negative dynamic pneumatic counterforce.

**[0015]** Palmer extensively teaches (US 006059742A, WO 201-515-7154 A1) the use of negative distending force to the anterior chest for purposes such as ventilation. Attachment is adhesive although movement of the device may be pneumatic. He does not teach: creation of an airtight extrathoracic compartment, sensing of ventilation, or application of dynamic positive and negative pneumatic counterforce.

**[0016]** The artificial lungs used during the early to mid 20th century achieved ventilation by varying the extrathoracic pressure of the whole thorax. These were not intended toward the purposes described and none of the related art or literature teaches the current technique.

BRIEF DESCRIPTION OF THE DRAWINGS

**[0017]** For a fuller understanding of the nature of the present invention, reference should be had to the following detailed description and preferred embodiment taken in connection with the accompanying drawing in which:

**[0018]** FIG. 1 is a diagrammatic representation of one embodiment of the method. This figure bisects a stylized

cross section of the device placed over a human rib fractured in two locations. Such fractures may represent a component of a flail chest injury.

#### DETAILED DESCRIPTION OF THE PREFERRED EMBODIMENT

**[0019]** Described is a method for dynamically treating and stabilizing the chest wall after injury or surgery. The device adjusts the air pressure in the region over the injury **4** in a manner reciprocal to the ventilatory respirophasic changes in intrathoracic pressure. This counteracts the intrathoracic forces that exacerbate pain or cause movement of fractures or free segments.

**[0020]** The device is a system that includes a number of components and capabilities that a practitioner of ordinary skill in the art would have little difficulty manufacturing using off-the-shelf components once having been taught the invention:

**[0021]** 1. An adjustable stabilizing platform **12** that may be applied to the rib cage **1** of a patient over the chest wall **2**, **3** injury, rib fracture **2**, flail segment **3** or incision. Other components of the system may be incorporated into this platform. The platform may be adjustable so as to optimize function.

**[0022]** 2. The patient-side surface of the device **4** have a bladder or adherent component at its circumferential edge **5**. Application to the chest wall creates an airtight compartment between the platform itself and the thorax **4**.

**[0023]** 3. The device may have a component **9** capable of placing this compartment **4** under negative and positive pressure and of rapidly varying the pressure in the enclosed space so as to minimize the pain or paradoxical motion of chest wall injuries, rib fractures, flail segments or incisions. Such a component would be likely to be an air pump and associated valves and connecting hoses.

**[0024]** 4. The device may have a mechanism **8** for measuring ventilation or, alternatively, receive inputs **7** from any system that measures patient respiration. Ventilation can be measured using multiple existing technologies, in particular electrical impedance and plethysmography.

**[0025]** 5. A control system capable, in combination with the pump, of varying the patient-side compartment pressure in a manner reciprocal to ventilation induced intrathoracic pressure **9**, **11**. Thus, this is a system for dynamically opposing the changes in intrathoracic pressure that accompany ventilation. Such a component is very likely to be a standard electrical control system or computer board.

**[0026]** 6. A harness system for stabilization during periods of positive pressure within the airtight compartment.

**[0027]** A practitioner of ordinary skill in the art would be able to obtain or construct all components of the system once taught the invention, including:

**[0028]** 1. The adjustable stabilizing frame or platform **12**.

**[0029]** 2. The adjustable circumferential component **5**, pliable and/or adherent material that is applied to the patient side circumference to create an airtight compartment **4**.

**[0030]** 3. The component or mechanism for varying the pressure within the airtight compartment **9**, **11**.

**[0031]** 4. The component or mechanism for measuring the intrinsic ventilation of the patient **8**.

**[0032]** 5. The component or mechanism for receiving inputs from other devices measuring patient ventilation and physiology **7**. Existing technologies such as electrical impedance or plethysmography are readily available for this purpose.

**[0033]** 6. The controller that interfaces between the measurement of patient ventilation and the component that varies pressure within the airtight compartment **10**.

#### Usefulness of the Disclosed Invention

**[0034]** This method and its preferred embodiments are intended to treat injuries to the thorax so as to lessen the pain suffered by the patient or further injury to the chest wall or underlying visceral organs. Once it is appreciated that the invention disclosed herein provides the capability to non-invasively treat or stabilize chest wall injuries, rib fractures, flail segments or incisions, the usefulness will be obvious to anyone with ordinary skill in the art of medicine, surgery or traumatology.

#### Non-Obviousness

**[0035]** The non-obviousness of the invention herein disclosed is demonstrated by the absence of any similar devices within the medical or intellectual property literature. Additionally, a number of large commercial enterprises produce devices for treatment or stabilization of injuries in prehospital, emergency department, operating room or battlefield settings, none of these companies have disclosed or developed devices or systems such as disclosed herein. None of the prior art or medical literature suggest combination of detecting ventilation associated changes in intrathoracic pressure so as to dynamically counteract it via an extrathoracic pneumatic compartment.

**[0036]** The non-obvious inventive step in discovery of the described method includes understanding that thoracic injuries, such as rib fractures and flail chest segments, may be treated regionally by means of real-time dynamic alteration of extrathoracic air pressure.

#### Other Publications Incorporated in the Current Application by Reference

**[0037]** Ciraulo, D. L., et al. "Flail chest as a marker for significant injuries." *J.Am.Coll.Surg.* 178 (1994): 466-70.

**[0038]** Dehghan, N., et al. "Flail chest injuries: a review of outcomes and treatment practices from the National Trauma Data Bank." *J.Trauma Acute.Care Surg.* 76.2 (2014): 462-68.

#### Modifications

**[0039]** It will be understood that many changes in the details, materials, steps and arrangements of elements, which have been herein described and illustrated in order to explain the nature of the invention, may be made by those skilled in the art without departing from the scope of the present invention.

**[0040]** Since many modifications, variations and changes in detail can be made to the described preferred embodiment of the invention, it is intended that all matters in the foregoing description be interpreted as illustrative and not in a limiting sense. Thus, the scope of the invention should be determined by the appended claims and their legal equivalents.

What is claimed is:

1. A method for treating chest wall injuries, the method comprising:

creating a localized airtight compartment external to the chest and fully covering the area of injury;

varying the pressure within the compartment real-time so as to provide a dynamic counterforce to the changes in intrathoracic pressure that occur during each ventilatory cycle.

2. A device as in claim 1 further comprising the real-time sensing of ventilation or chest wall motion and dynamic variation of the pressure within the localized airtight compartment in such a manner that the pressure within the airtight compartment opposes pressure changes within the chest.

3. A device as in claim 2 further comprising real-time sensing of paradoxical flail chest free-segment movement and dynamic variation of the pressure within the localized airtight compartment in such a manner that the pressure within the airtight compartment opposes such paradoxical motion.

4. A device as in claim 2 also incorporating an adherent material on the patient-side surface of the apparatus at its circumference such that an adherent airtight compartment is created between the frame and the thorax.

5. A device as in claim 2 also incorporating an adjustable bladder component on the patient-side surface of the appara-

tus at its circumference such that the airtight compartment may adjust to chest wall anatomy.

6. A device as in claim 2 also incorporating the capability of receiving input signals from other devices measuring ventilation or chest wall movement.

7. A device as in claim 2 in which the frame is adjustable so as to better configure to the shape of the chest wall.

8. A device as in claim 2 in which the power source is contained within the device in the form of a battery.

9. A device as in claim 2 in which the apparatus incorporates a patient side sensor capable of detecting or measuring paradoxical chest wall motion and incorporating that data in the variation of pressure within the airtight compartment.

10. A device as in claim 2 in which the controller may be adjusted by an operator based on the patient's subjective sense of painful paradoxical movement.

11. A device as in claim 2 in which the controller is of the form of general purpose computer and algorithm capable of synthesizing inputs from the patient and operator so as to minimize paradoxical chest wall motion.

\* \* \* \* \*