



(19) **United States**

(12) **Patent Application Publication**  
**Hagihara et al.**

(10) **Pub. No.: US 2006/0256043 A1**

(43) **Pub. Date: Nov. 16, 2006**

(54) **PLASMA DISPLAY DEVICE**

**Publication Classification**

(76) Inventors: **Sojiro Hagihara**, Yokohama (JP);  
**Akihiro Machida**, Kyonan (JP);  
**Hidegori Ohnuki**, Kawasaki (JP);  
**Hideaki Ohki**, Tokyo (JP)

(51) **Int. Cl.**  
**G09G 3/28** (2006.01)  
(52) **U.S. Cl.** ..... **345/67**

(57) **ABSTRACT**

The plasma display device includes connecting means for connecting the X/Y electrodes of the plasma display panel and the X/Y electrode drive circuits. In the X electrode pattern and the Y electrode pattern on the printed board in the connecting means, a current path connecting the center electrodes of the plasma display panel and the X electrode drive circuit or Y electrode drive circuit is longer than a current path connecting the peripheral electrodes and the X electrode drive circuit or Y electrode drive circuit. The current paths at the plasma display panel side are in the U-shape folded in the upper part and the lower part in the periphery of the plasma display panel, respectively. Also, the current paths are first connected to the upper or lower electrodes, and then sequentially connected to the center electrodes via the upper part and the lower part.

Correspondence Address:  
**ANTONELLI, TERRY, STOUT & KRAUS,**  
**LLP**  
**1300 NORTH SEVENTEENTH STREET**  
**SUITE 1800**  
**ARLINGTON, VA 22209-3873 (US)**

(21) Appl. No.: **11/418,141**

(22) Filed: **May 5, 2006**

(30) **Foreign Application Priority Data**

May 13, 2005 (JP) ..... 2005-141134

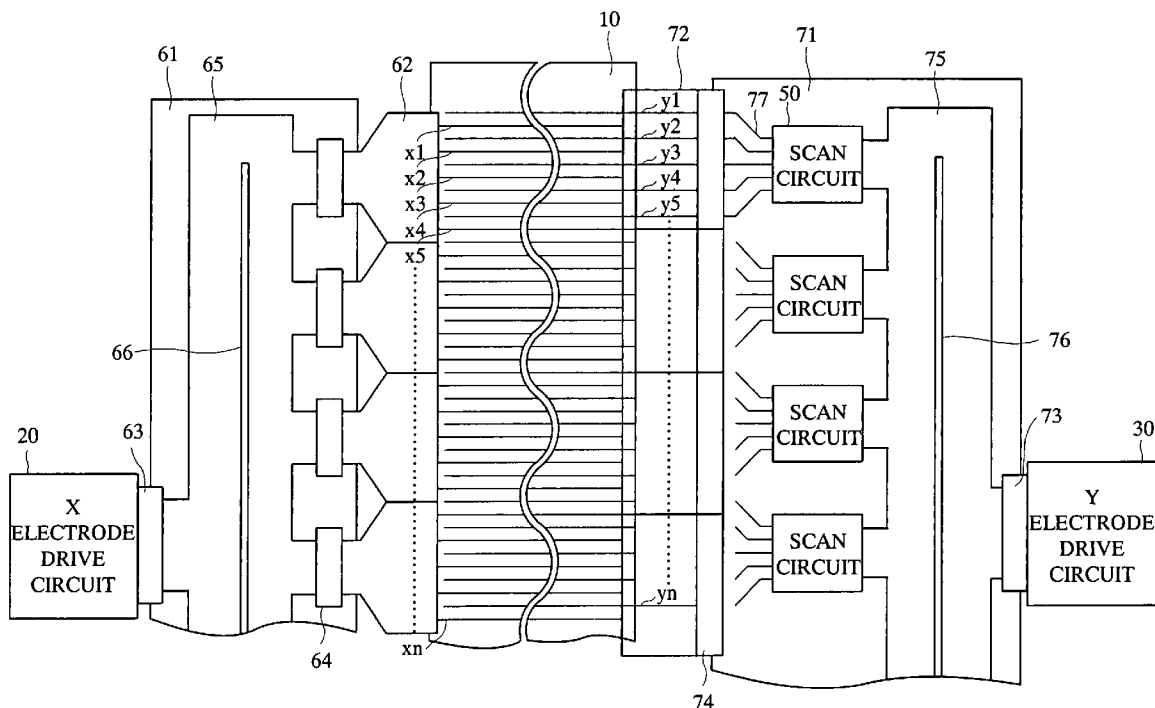

FIG. 1

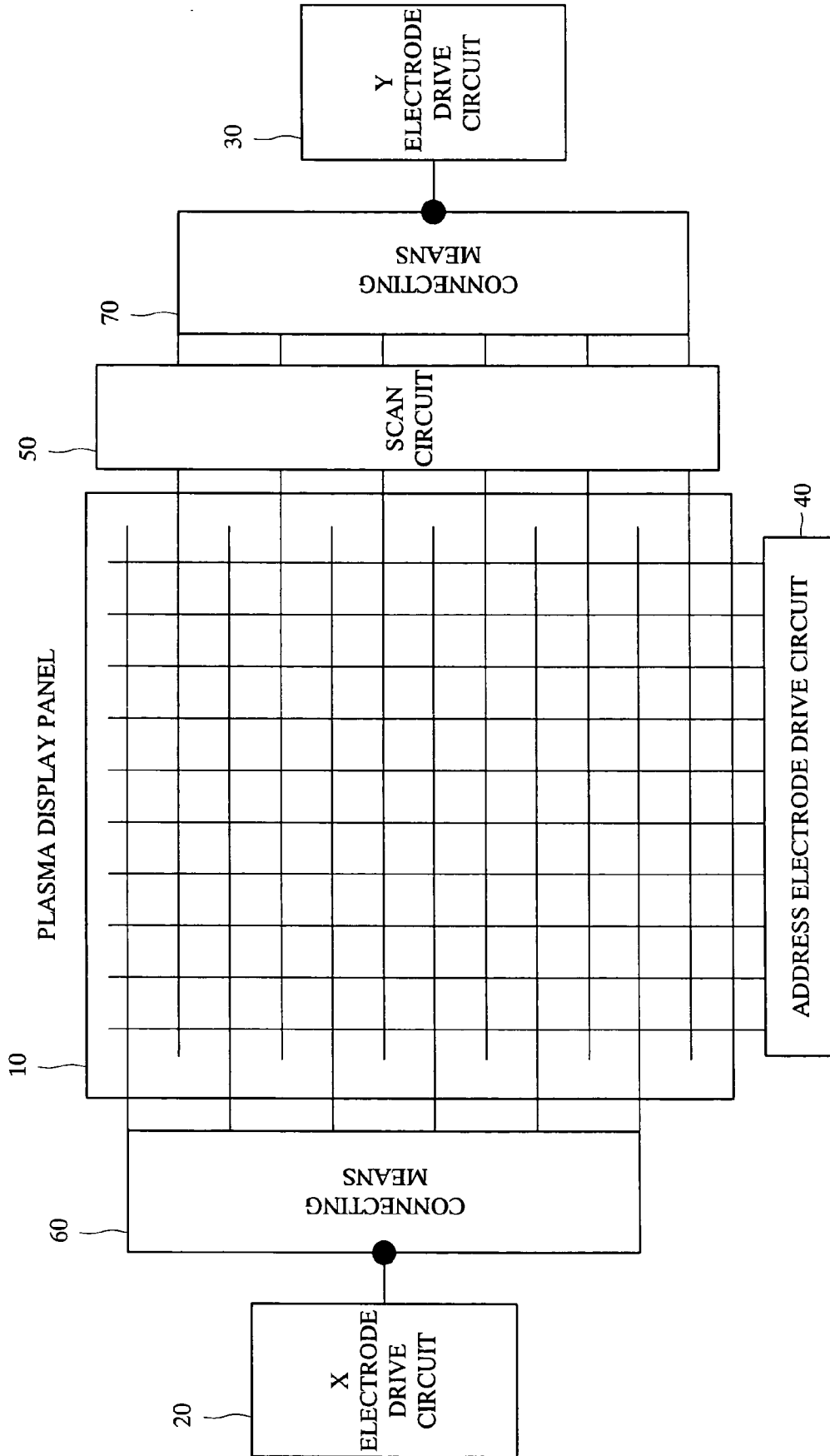

FIG. 2

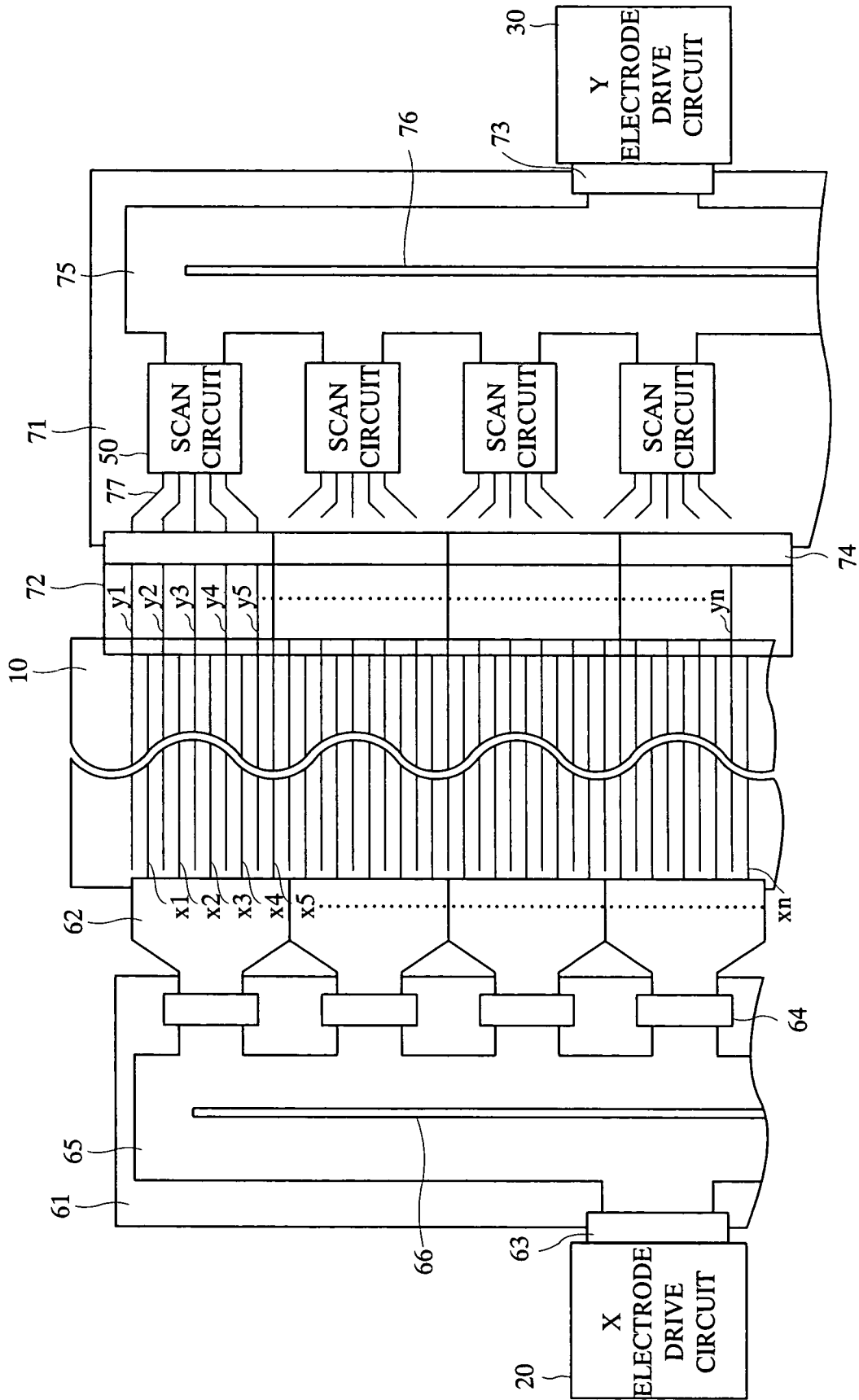

FIG. 3

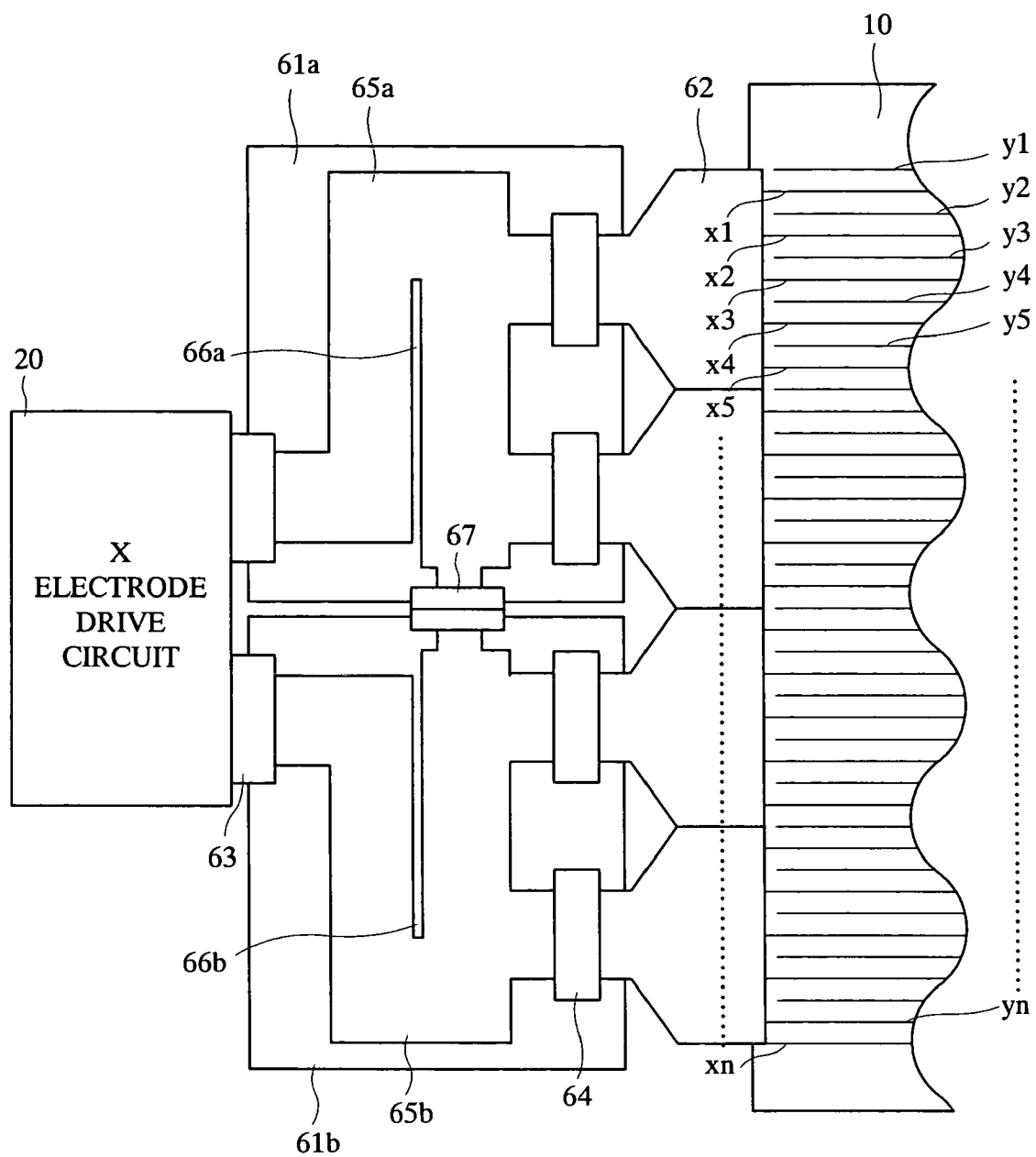

FIG. 4

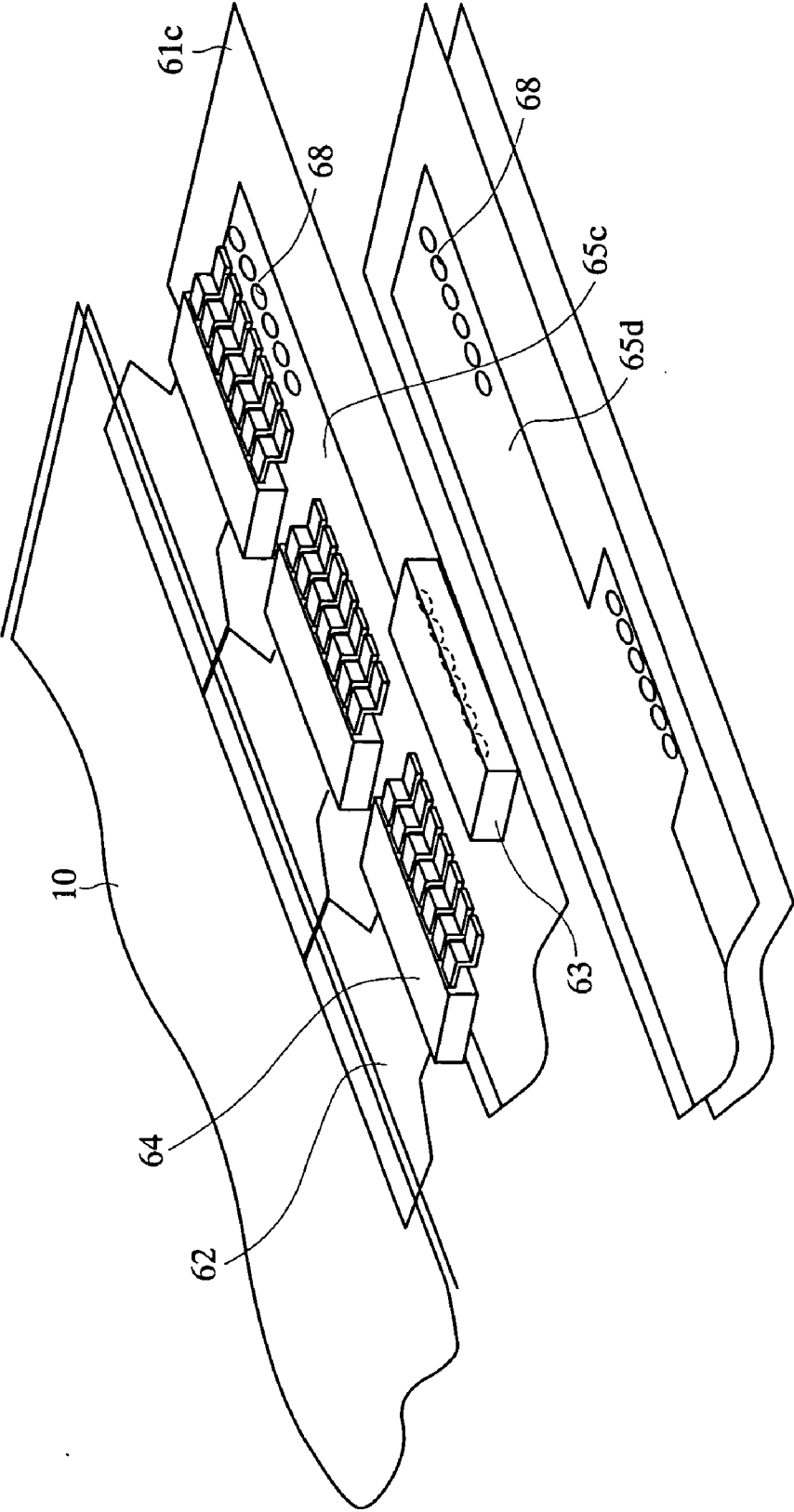

FIG. 5

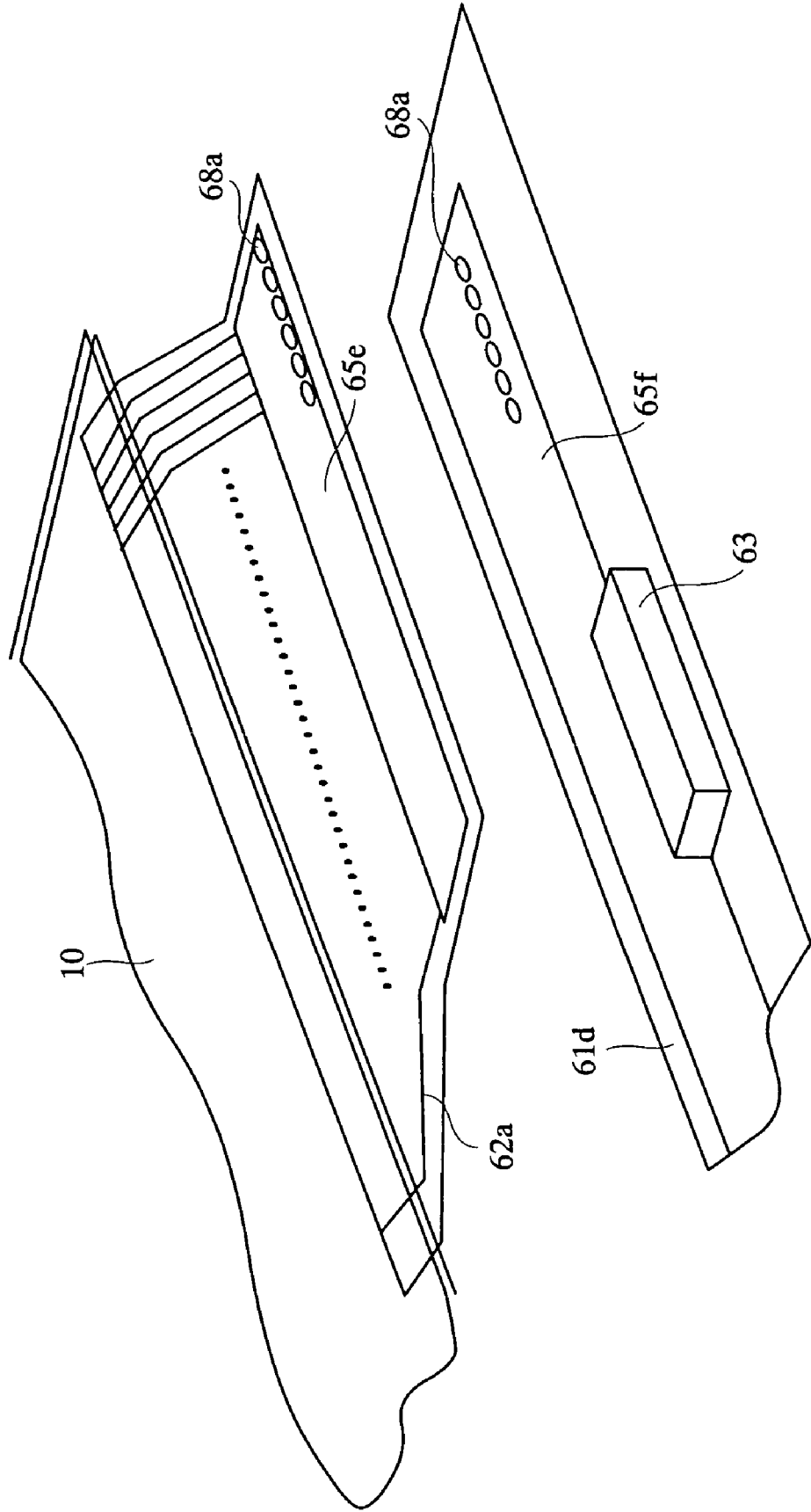

FIG. 6

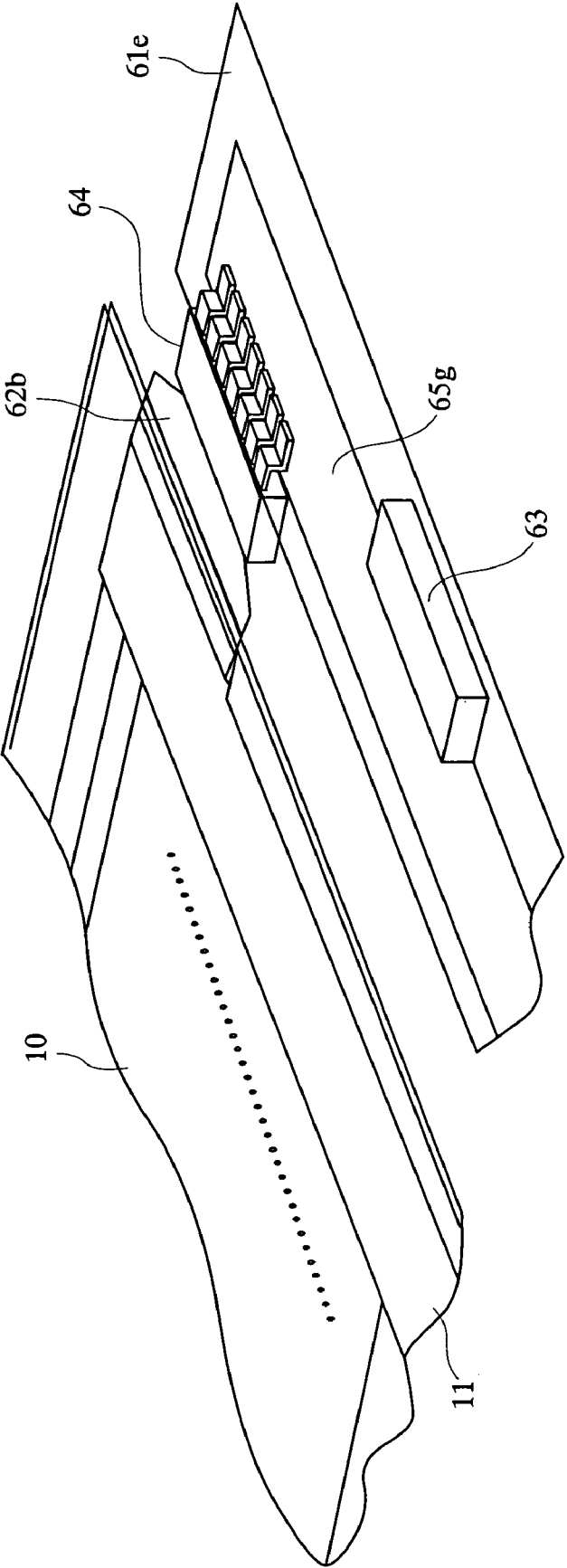

FIG. 7

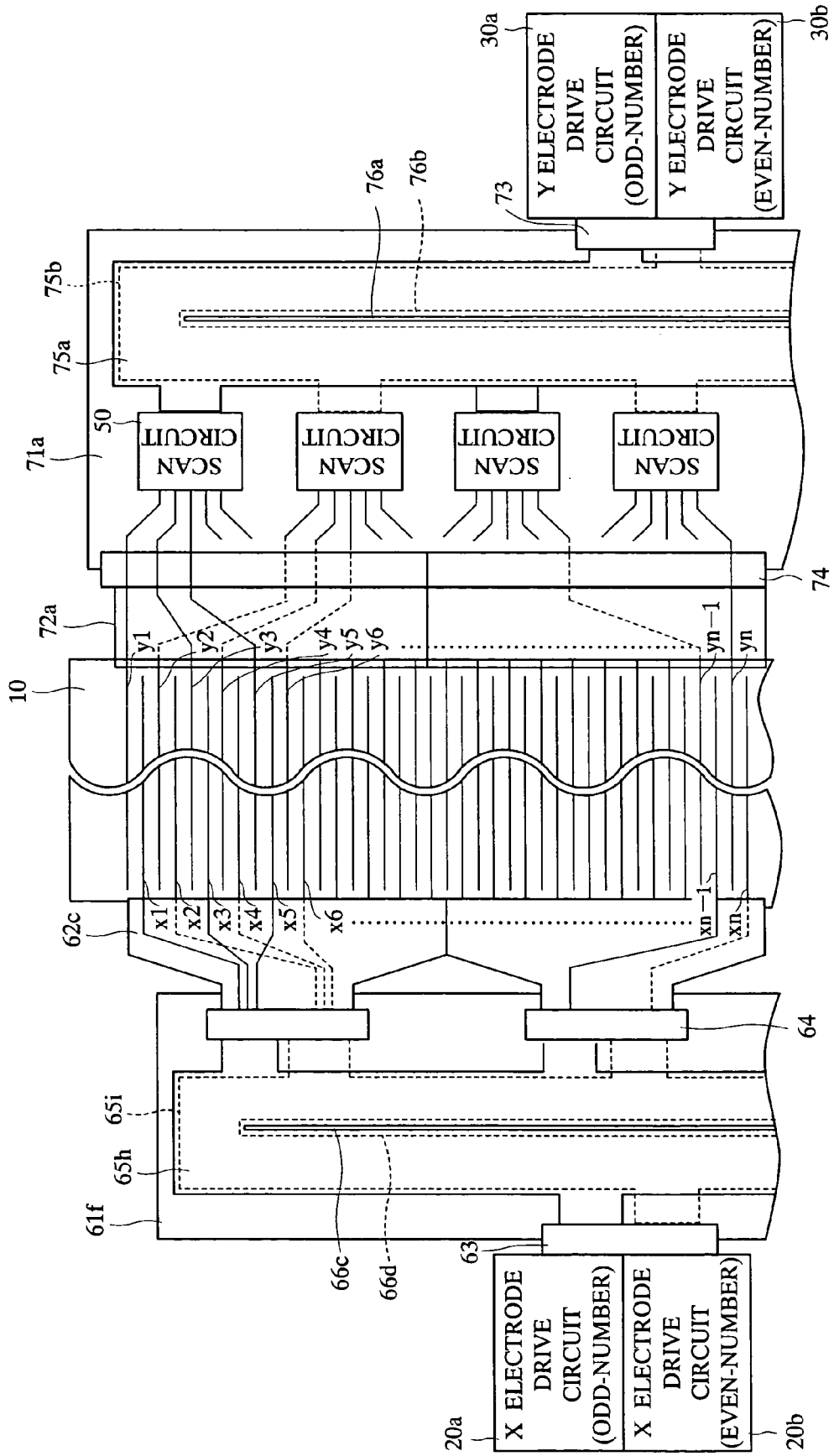



FIG. 8

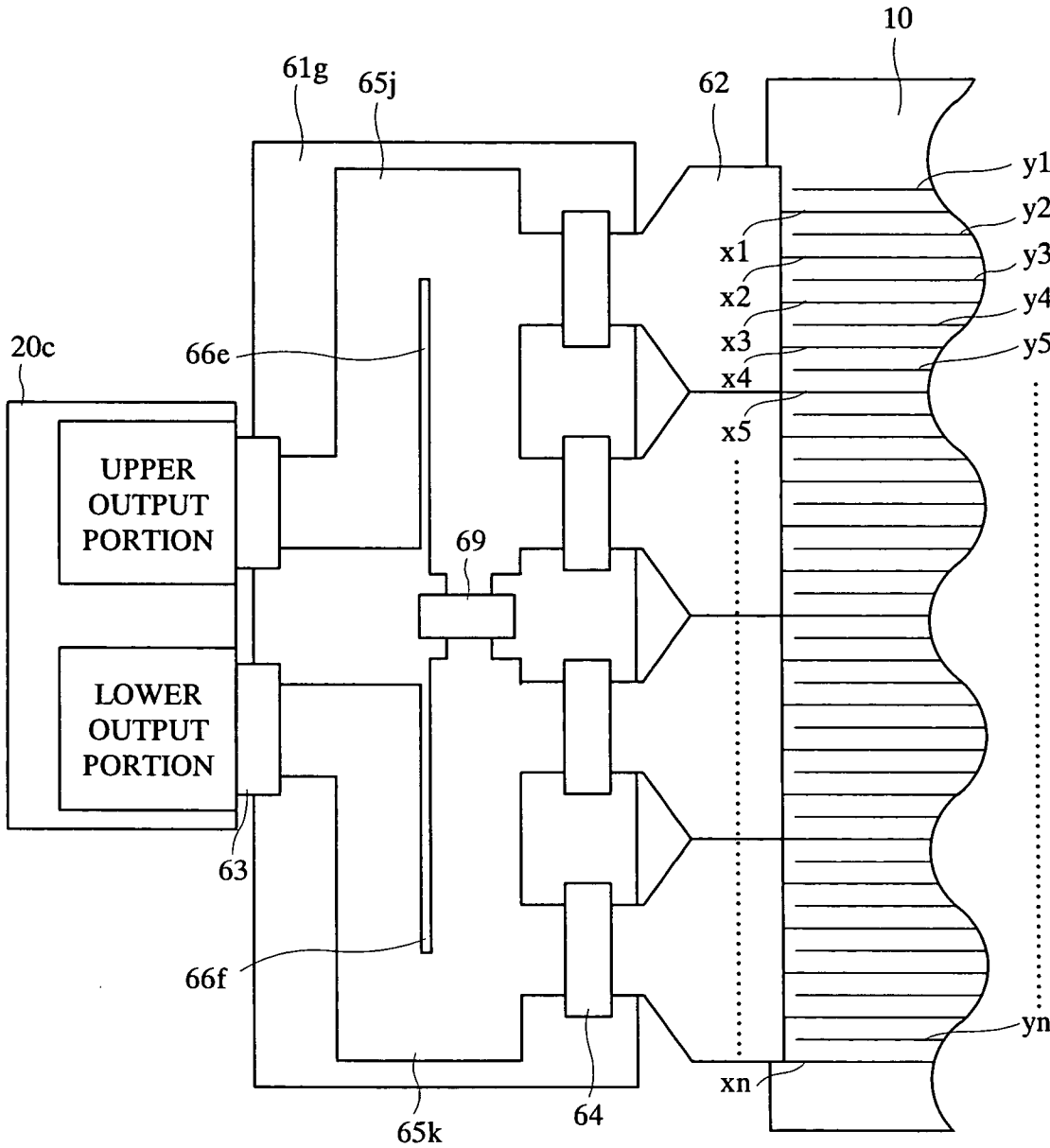

FIG. 9A

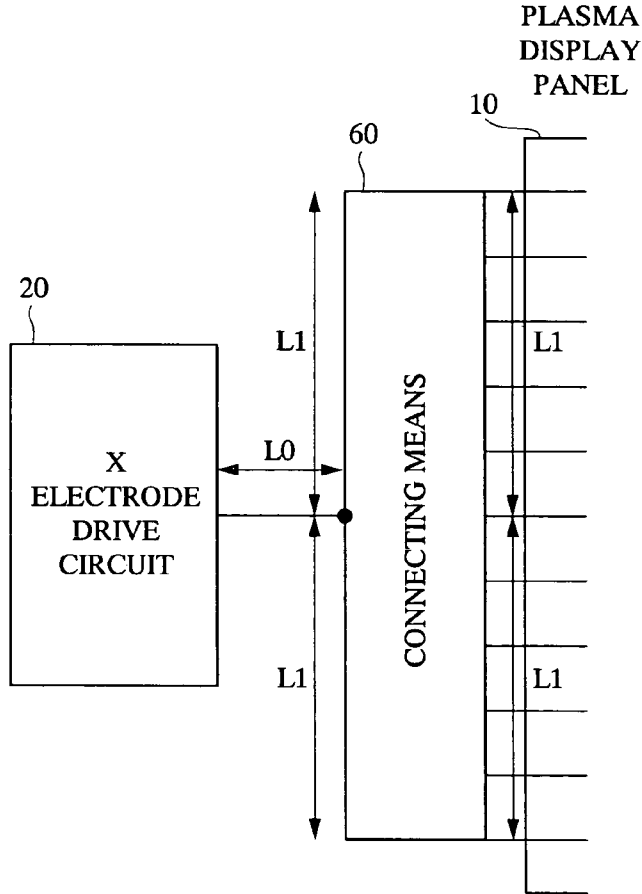

FIG. 9B

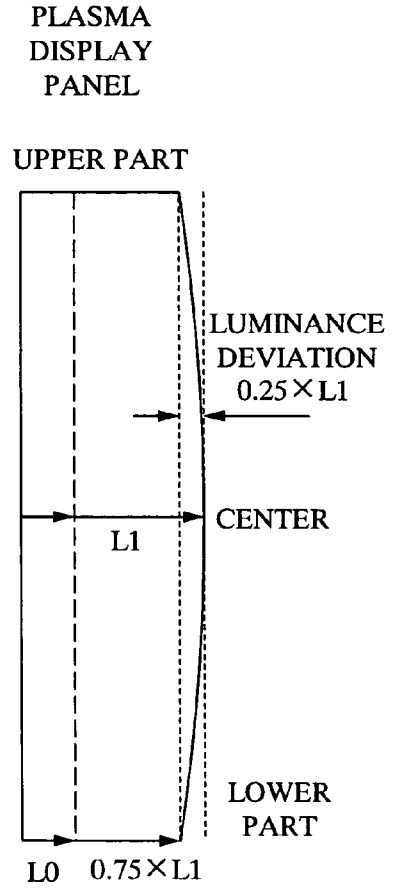

FIG. 10A

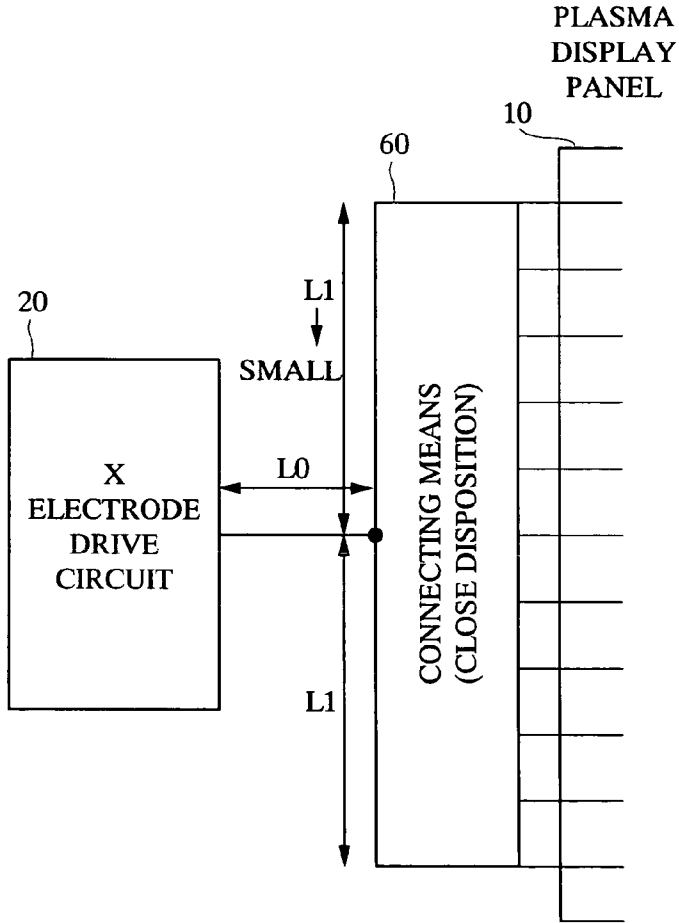

FIG. 10B

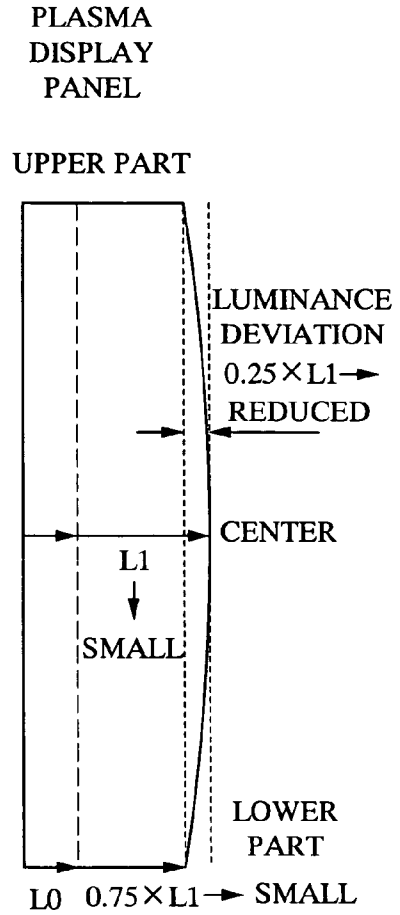

FIG. 11A

FIG. 11B

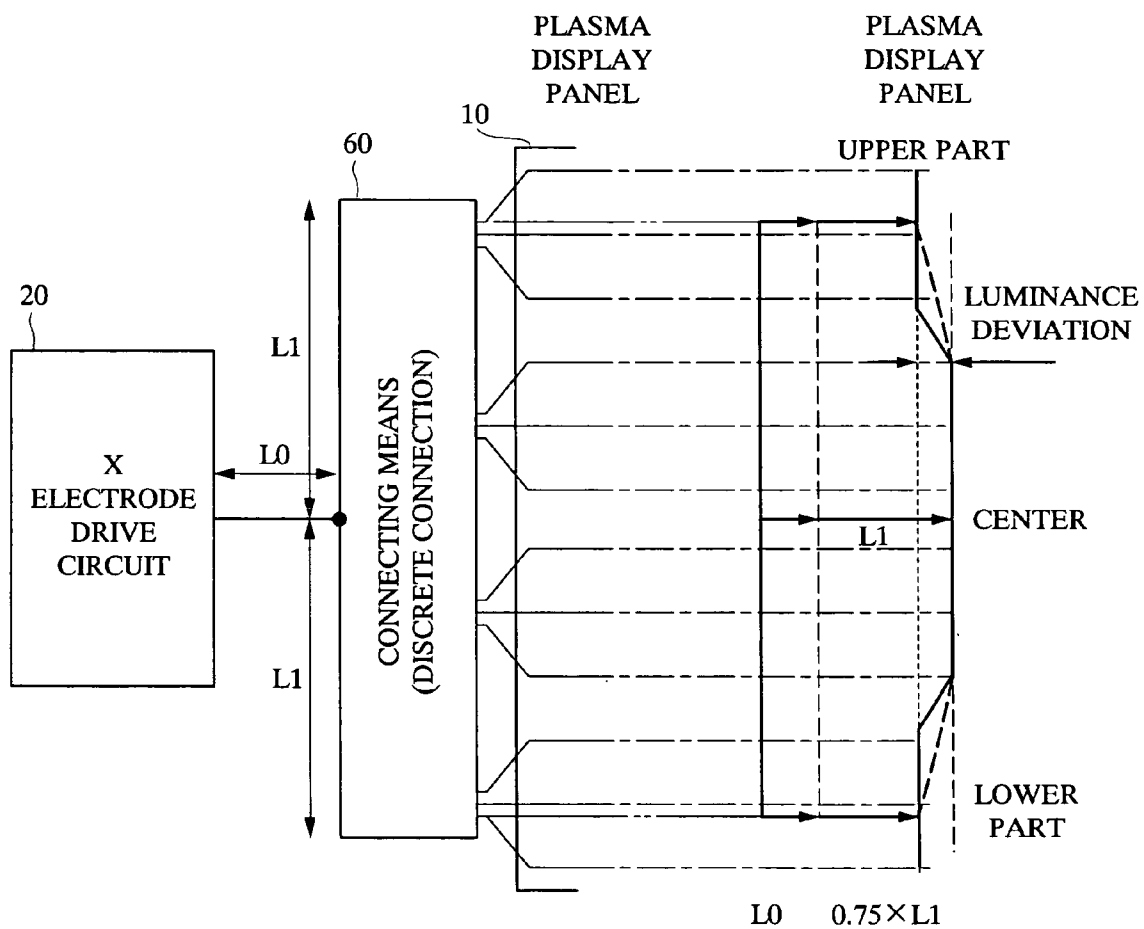

FIG. 12

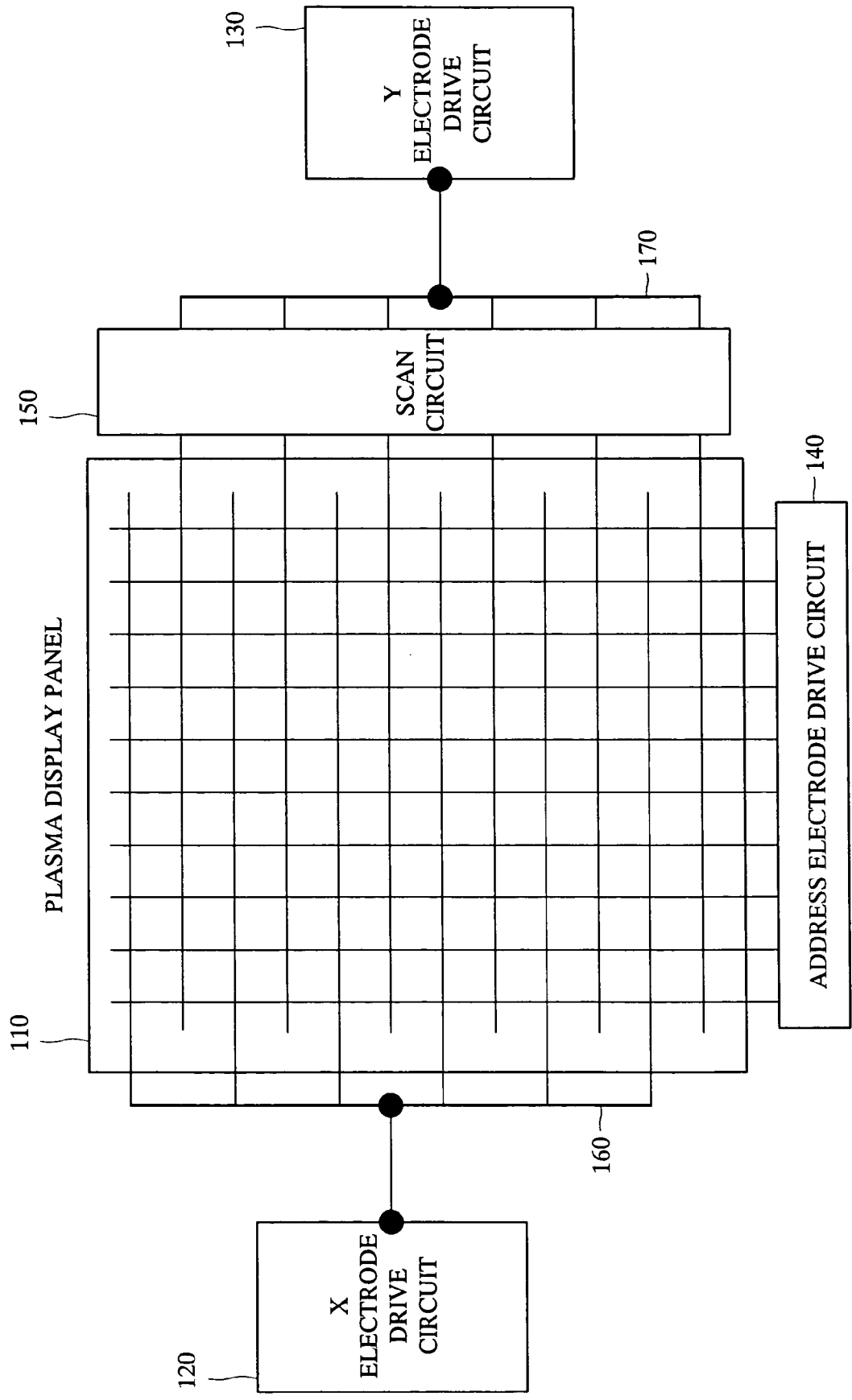

FIG. 13

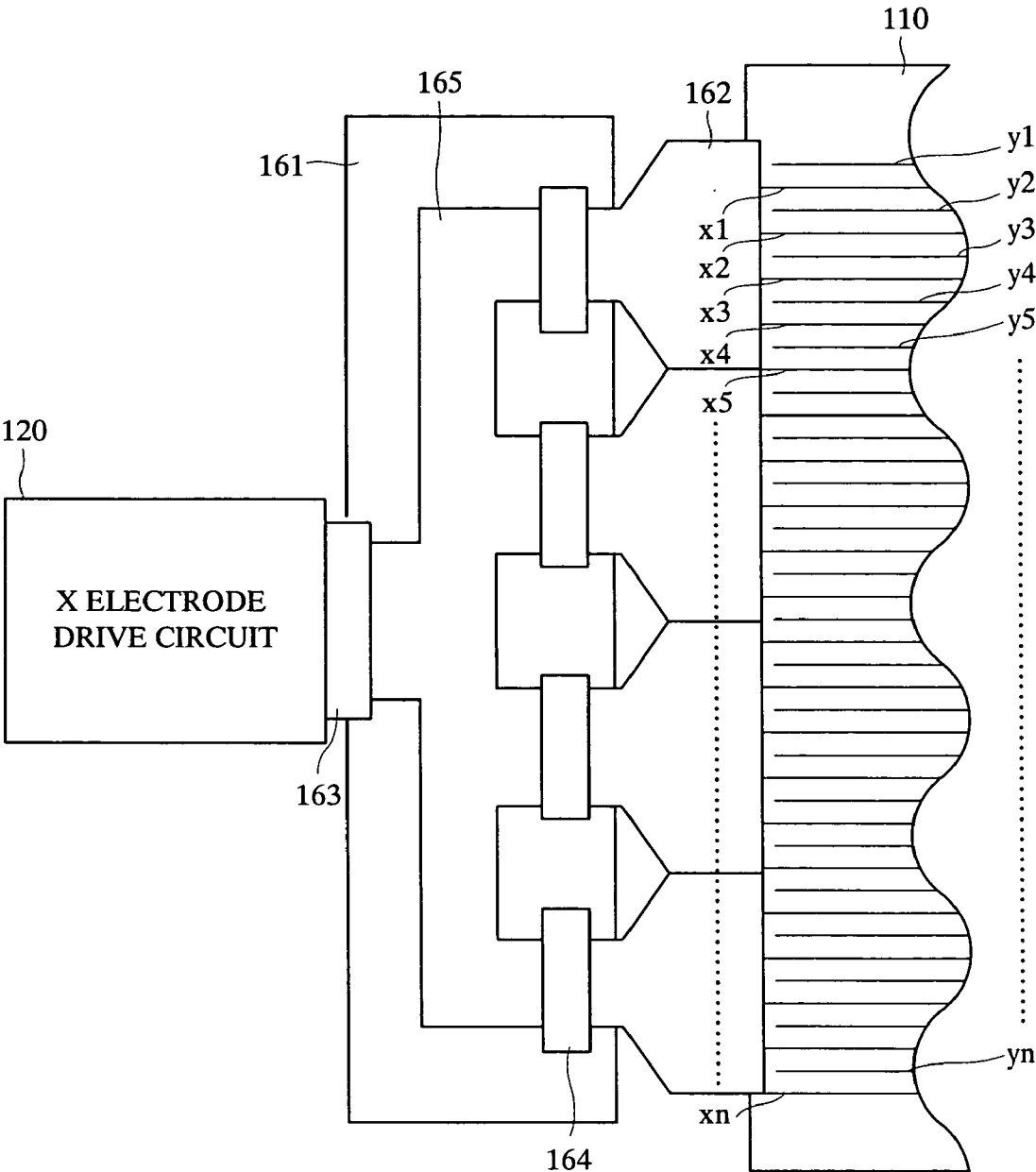

FIG. 14

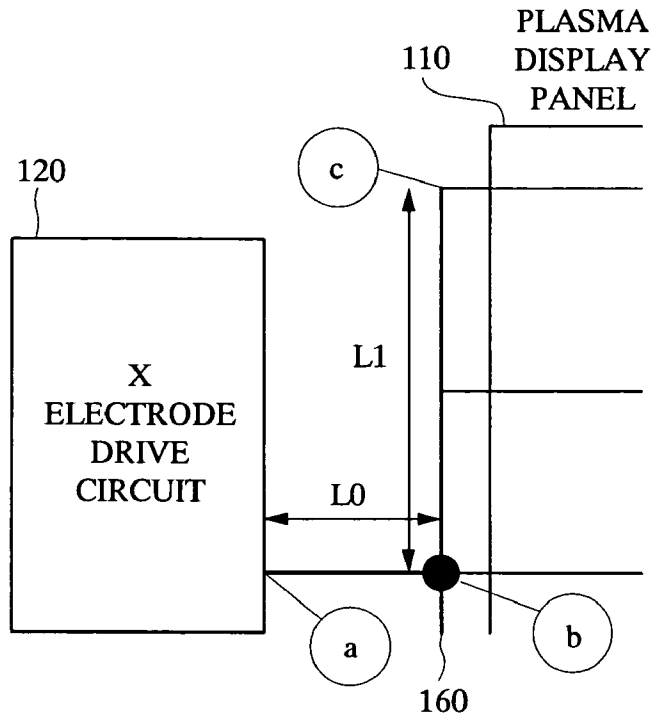

FIG. 15

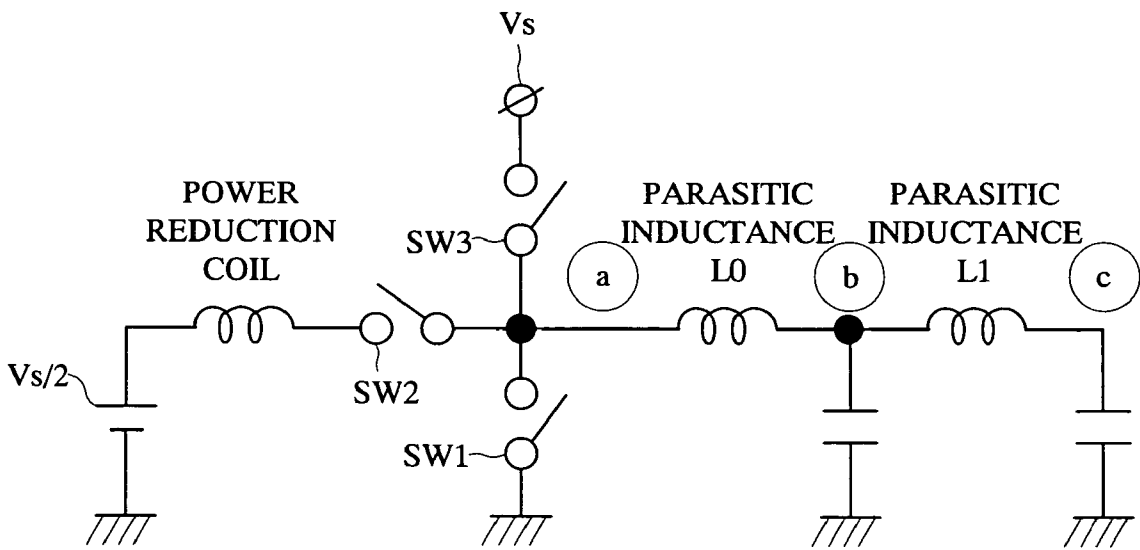

FIG. 16

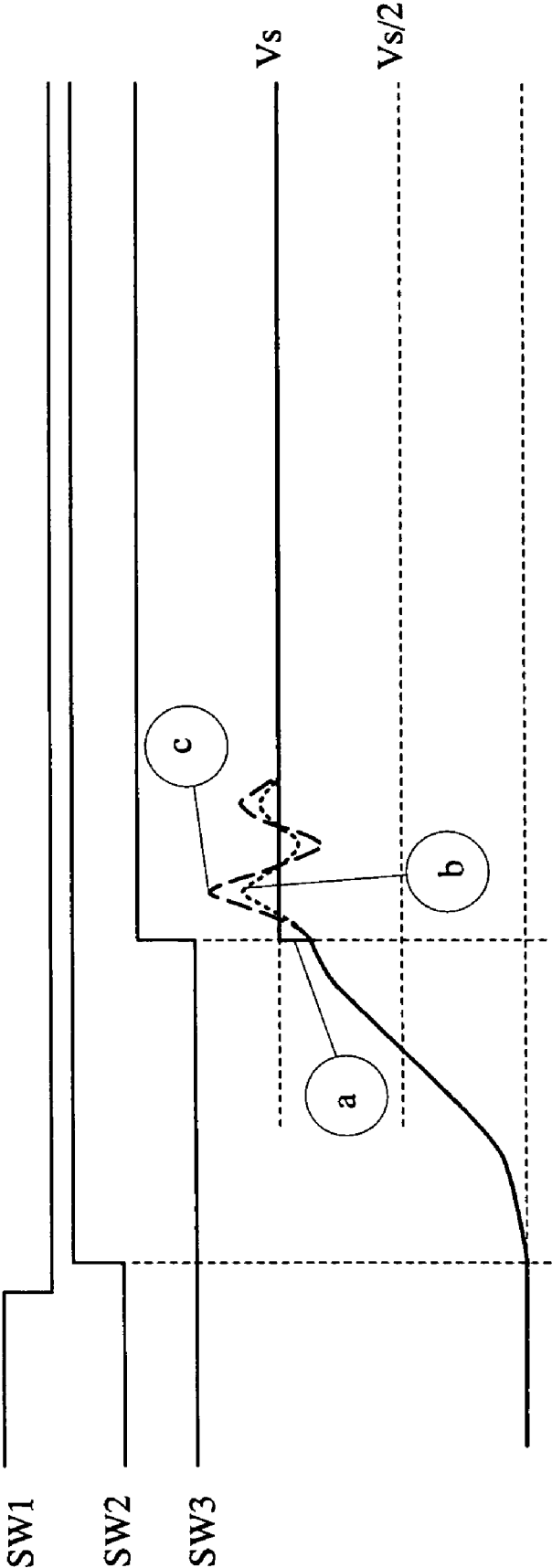



FIG. 17A

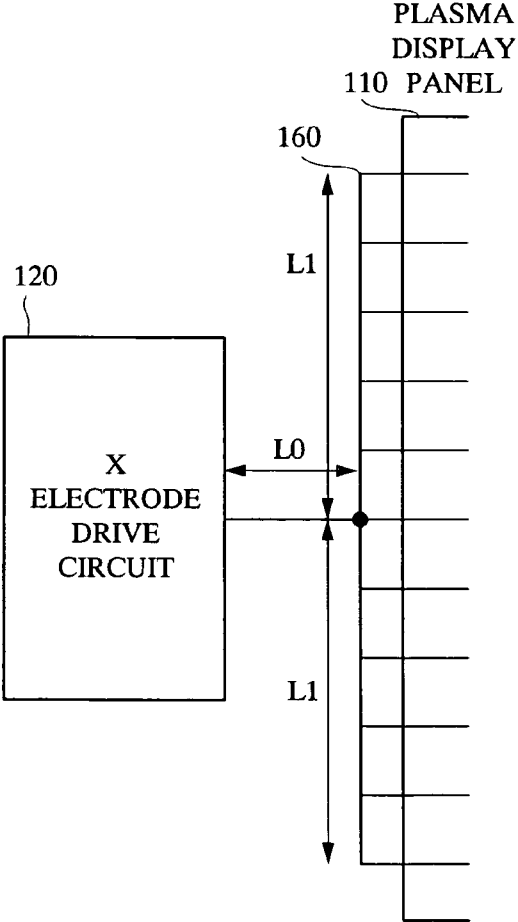

FIG. 17B

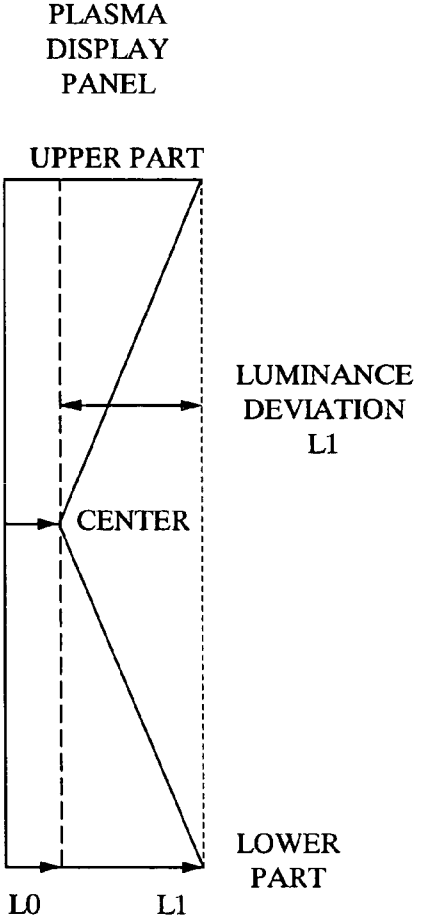
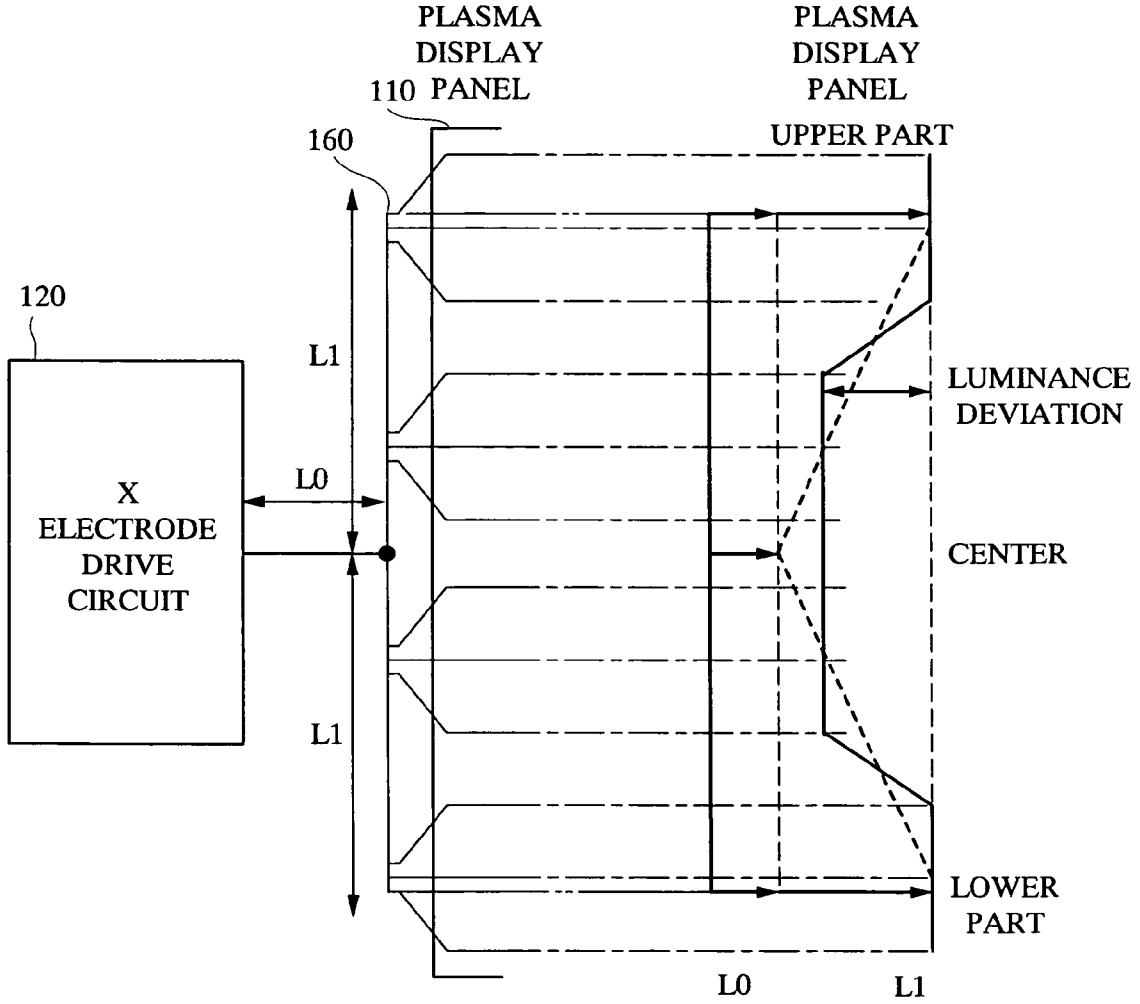

FIG. 18A

FIG. 18B



## PLASMA DISPLAY DEVICE

### CROSS-REFERENCE TO RELATED APPLICATION

[0001] The present application claims priority from Japanese Patent Application No. JP 2005-141134 filed on May 13, 2005, the content of which is hereby incorporated by reference into this application.

### TECHNICAL FIELD OF THE INVENTION

[0002] The present invention relates to a technology for a plasma display device. More particularly, it relates to a technology effectively applied to a connection structure between X/Y electrodes and X/Y electrode drive circuits in a plasma display panel.

### BACKGROUND OF THE INVENTION

[0003] For example, a conventional plasma display device is comprised of, as shown in FIG. 12, a plasma display panel 110, an X electrode drive circuit 120 for driving a plurality of X electrodes of the plasma display panel 110, a Y electrode drive circuit 130 for driving a plurality of Y electrodes thereof, an address electrode drive circuit 140 for driving a plurality of address electrodes thereof, a scan circuit 150 for scanning a plurality of Y electrodes thereof, and others. In such a structure, each X electrode and the X electrode drive circuit 120, and each Y electrode and the Y electrode drive circuit 130 in the plasma display panel 110 are electrically connected through connecting means 160 and 170 such as a printed board and flexible substrate, respectively.

[0004] More specifically, the connection between each X electrode of the plasma display panel 110 and the X electrode drive circuit 120 will be described as an example with reference to FIG. 13. Each X electrode of the plasma display panel 110 is connected to the X electrode drive circuit 120 through a printed board 161 and a flexible substrate 162. The X electrode drive circuit 120 and the printed board 161, and the printed board 161 and the flexible substrate 162 are connected via connectors 163 and 164, respectively, and a conductor of the flexible substrate 162 is connected to each X electrode of the plasma display panel 110 by thermocompression or the like. Further, an X electrode pattern 165 for connecting the connector 163 and the connectors 164 is formed on the printed board 161.

[0005] As a technology which focuses attention on a luminance difference between regions in a screen in such a plasma display device, a technology described in Japanese Patent Application Laid-Open Publication No. 2000-284747 (Patent Document 1) is known.

### SUMMARY OF THE INVENTION

[0006] In the plasma display device described above, the X electrode drive circuit and the Y electrode drive circuit are electrically connected to the plasma display panel through a printed board and a flexible substrate. However, due to the difference in wiring length of the physical current paths, an inductance deviation occurs, and a phenomenon occurs in which a luminance difference becomes apparent in uniform display on the entire screen. In particular, it is a notable trend in the enlargement of the screen size of the plasma display panel.

[0007] For example, in the connection between the X electrode drive circuit 120 and the plasma display panel 110 (from the center to the upper part) shown in FIG. 14 in the above-described connection form of FIG. 13, an inductance in the current path between the X electrode drive circuit (a) and the center electrode (b) of the plasma display panel is L0, and an inductance in the current path between the center electrode (b) and the upper electrode (c) is L1.

[0008] An equivalent circuit in this case can be expressed by a circuit structure shown in FIG. 15 in which power supplies (Vs, Vs/2), a power reduction coil, switches (SW1 to SW3), parasitic inductances (L0, L1) and others are connected. Point (a) corresponds to a connection point between the switches SW1, SW2, and SW3 and L0, point (b) corresponds to a connection point between L0 and L1, and point (c) corresponds to an open point of L1. Drive waveforms at each of the points (a), (b), (c) are as shown in FIG. 16, in which overshoot and undershoot relative to a drive waveform (Vs) at point (a) occur at point (b) and overshoot and undershoot voltages over those at the point (b) occur at point (c).

[0009] Such a parasitic inductance distribution can be also considered as a phenomenon of luminance distribution. In considering this phenomenon for the entire plasma display panel 110, as shown in a parasitic inductance distribution of FIG. 17A and a luminance distribution of FIG. 17B, the center of the plasma display panel 110 has the luminance corresponding to L0, and the upper and lower parts of the plasma display panel 110 have the luminance corresponding to L0+L1. Therefore, a luminance difference corresponding to a deviation by L1 occurs between the center part and the upper and lower parts. Hence, it has been desired to suppress this luminance difference below a permissible value in the trend of enlargement of the screen size of the plasma display panel 110.

[0010] In particular, in the case where the flexible substrate is separated into those for the X electrodes and the Y electrodes along with the enlargement in the screen size of the plasma display panel, further techniques are required. In promoting the separation of the flexible substrate, the luminance difference is apt to occur due to the inductance deviation caused by the discretization of common impedance. For example, a luminance distribution in the case of the discrete connection of the flexible substrates corresponds to a parasitic inductance distribution of FIG. 18A and a luminance distribution of FIG. 18B (a dashed line in the luminance distribution is that of FIG. 17B).

[0011] The parasitic inductance increases more in the upper and lower parts of the plasma display panel. Thus, a resonance voltage generated by the parasitic inductance and the panel capacitance becomes larger in the upper and lower parts. Consequently, there arises a problem that a luminance ratio is higher in the upper and lower parts than that in the center of the plasma display panel.

[0012] The technology in Patent Document 1 focuses attention on the luminance difference between regions in the screen. However, it does not describe a connection structure between the X/Y electrodes and the X/Y electrode drive circuits in the plasma display panel.

[0013] Therefore, an object of the present invention is to provide a plasma display device capable of increasing the

luminance in the center part of a screen, by suppressing an inductance deviation to reduce a luminance difference in the entire screen below a permissible value in order to solve the problems described above.

[0014] The above and other objects and novel characteristics of the present invention will be apparent from the description of this specification and the accompanying drawings.

[0015] The typical ones of the inventions disclosed in this application will be briefly described as follows.

[0016] The plasma display device according to the present invention comprises: connecting means for connecting each X electrode of a plasma display panel and an X electrode drive circuit and connecting each Y electrode of the plasma display panel and a Y electrode drive circuit, respectively, and the plasma display device has features as follows.

[0017] (1) In the connecting means, a current path connecting center electrodes of the plasma display panel and the X electrode drive circuit or Y electrode drive circuit is longer than a current path connecting peripheral electrodes of the plasma display panel and the X electrode drive circuit or Y electrode drive circuit.

[0018] (2) The current paths at the plasma display panel side of the connecting means are in a U-shape folded in the upper part and the lower part in the periphery of the plasma display panel, respectively. The current paths are first connected to the upper electrodes and lower electrodes of the plasma display panel, respectively, extend through an upper part and a lower part, and then sequentially connected to the center electrodes of the plasma display panel.

[0019] (3) A first current path extending through the upper part of the plasma display panel and a second current path extending through the lower part of the plasma display panel are connected near the center electrodes of the plasma display panel. The means for connecting the first current path and the second current path is a conductor, a semiconductor device or a device to be conducted in a high frequency region such as a capacitor.

[0020] (4) A pair of current paths in the folded U-shape are disposed so closely that electromagnetic induction occurs. As a method of closely disposing the pair of current paths, a slit-like cutout is formed on a conductor so that the current paths are disposed in parallel, adjacent layers of a multilayer substrate are used, or different types of substrates are attached to each other.

[0021] (5) A common electrode portion in which a plurality of X electrodes disposed on the plasma display panel are connected at an end face of the plasma display panel is used in place of the connection portion in the folded U-shape at the plasma display panel side.

[0022] (6) The connecting means and the plurality of X electrodes and Y electrodes are connected via a semiconductor device, respectively.

[0023] The effects obtained by typical aspects of the present invention will be briefly described below.

[0024] According to the present invention, it is possible to provide a plasma display device capable of increasing the luminance in the center part of a screen, by suppressing an

inductance deviation to reduce a luminance difference in the entire screen below a permissible value.

#### BRIEF DESCRIPTIONS OF THE DRAWINGS

[0025] FIG. 1 is a diagram showing a schematic structure of a plasma display device according to one embodiment of the present invention;

[0026] FIG. 2 is a diagram showing a connection form between a plasma display panel and X and Y electrode drive circuits in the plasma display device according to one embodiment of the present invention;

[0027] FIG. 3 is a diagram showing a connection form in which a current path extending through the upper part of the plasma display panel and a current path extending through the lower part thereof are connected near center electrodes in the plasma display device according to one embodiment of the present invention;

[0028] FIG. 4 is a diagram showing a connection form in which adjacent layers of a multilayer substrate are used to closely dispose a pair of current paths in the plasma display device according to one embodiment of the present invention;

[0029] FIG. 5 is a diagram showing a connection form in which different types of substrates are attached to each other to closely dispose a pair of current paths in the plasma display device according to one embodiment of the present invention;

[0030] FIG. 6 is a diagram showing a connection form in which a common electrode portion connected at an end face of the plasma display panel is used in place of a connection portion in a folded U-shape at the plasma display panel side in the plasma display device according to one embodiment of the present invention;

[0031] FIG. 7 is a diagram showing a connection form between a plasma display panel having an odd/even separation structure and the X and Y electrode drive circuits in the plasma display device according to one embodiment of the present invention;

[0032] FIG. 8 is a diagram showing a connection form in which a current path extending through the upper part and a current path extending through the lower part are connected near center electrodes when an output portion of the X electrode drive circuit is separated into an upper part and a lower part in the plasma display device according to one embodiment of the present invention;

[0033] FIG. 9A is a diagram showing a parasitic inductance distribution when a current path in an X electrode pattern and a current path in a Y electrode pattern are formed into a U-shape folded in the periphery of the plasma display panel in the plasma display device according to one embodiment of the present invention;

[0034] FIG. 9B is a diagram showing a luminance distribution when a current path in an X electrode pattern and a current path in a Y electrode pattern are formed into a U-shape folded in the periphery of the plasma display panel in the plasma display device according to one embodiment of the present invention;

[0035] FIG. 10A is a diagram showing a parasitic inductance distribution when a pair of current paths in a folded

U-shape are disposed in parallel and so closely that electromagnetic induction occurs in the plasma display device according to one embodiment of the present invention;

[0036] **FIG. 10B** is a diagram showing a luminance distribution when a pair of current paths in a folded U-shape are disposed in parallel and so closely that electromagnetic induction occurs in the plasma display device according to one embodiment of the present invention;

[0037] **FIG. 11A** is a diagram showing a parasitic inductance distribution when flexible substrates are discretely connected in the plasma display device according to one embodiment of the present invention;

[0038] **FIG. 11B** is a diagram showing a luminance distribution when flexible substrates are discretely connected in the plasma display device according to one embodiment of the present invention;

[0039] **FIG. 12** is a diagram showing a schematic structure of a conventional plasma display device studied as a premise of the present invention;

[0040] **FIG. 13** is a diagram showing a connection form between a plasma display panel and an X electrode drive circuit in the conventional plasma display device studied as a premise of the present invention;

[0041] **FIG. 14** is a diagram showing a parasitic inductance distribution in a connection portion between the plasma display panel and the X electrode drive circuit in the conventional plasma display device studied as a premise of the present invention;

[0042] **FIG. 15** is a diagram showing an equivalent circuit in the connection portion between the plasma display panel and the X electrode drive circuit in the conventional plasma display device studied as a premise of the present invention;

[0043] **FIG. 16** is a diagram showing drive waveforms in the connection portion between the plasma display panel and the X electrode drive circuit in the conventional plasma display device studied as a premise of the present invention;

[0044] **FIG. 17A** is a diagram showing a parasitic inductance distribution in the connection portion between the plasma display panel and the X electrode drive circuit in the conventional plasma display device studied as a premise of the present invention;

[0045] **FIG. 17B** is a diagram showing a luminance distribution in the connection portion between the plasma display panel and the X electrode drive circuit in the conventional plasma display device studied as a premise of the present invention;

[0046] **FIG. 18A** is a diagram showing a parasitic inductance distribution when flexible substrates are discretely connected in the conventional plasma display device studied as a premise of the present invention; and

[0047] **FIG. 18B** is a diagram showing a luminance distribution when flexible substrates are discretely connected in the conventional plasma display device studied as a premise of the present invention.

#### DESCRIPTIONS OF THE PREFERRED EMBODIMENTS

[0048] Hereinafter, embodiments of the present invention will be described in detail with reference to the accompa-

nying drawings. Note that components having the same function are denoted by the same reference symbols throughout the drawings for describing the embodiment, and the repetitive description thereof will be omitted.

[0049] First, an example of a structure of a plasma display device according to one embodiment of the present invention will be described with reference to **FIG. 1**. **FIG. 1** shows a schematic structure of the plasma display device.

[0050] The plasma display device according to the present embodiment includes a plasma display panel **10**, an X electrode drive circuit **20** for driving a plurality of X electrodes of the plasma display panel **10**, a Y electrode drive circuit **30** for driving a plurality of Y electrodes of the plasma display panel **10**, an address electrode drive circuit **40** for driving a plurality of address electrodes of the plasma display panel **10**, a scan circuit **50** for scanning a plurality of Y electrodes of the plasma display panel **10**, and others. In such a structure, each X electrode in the plasma display panel **10** and the X electrode drive circuit **20**, and each Y electrode in the plasma display panel **10** and the Y electrode drive circuit **30** are electrically connected through connecting means **60** and **70** such as a printed board and flexible substrate, respectively.

[0051] In the plasma display device formed as described above, X electrodes and Y electrodes which are disposed in parallel are formed and address electrodes are formed orthogonally thereto in the plasma display panel **10**. The X electrodes and the Y electrodes mainly perform sustain discharge for the display light emission. A voltage pulse is repeatedly applied between the X electrodes and the Y electrodes to perform the sustain discharges. Further, the Y electrode functions also as a scan electrode when writing display data. On the other hand, the address electrode is used to select a discharge cell to emit light, and a voltage for performing write discharge for selecting a discharge cell is applied between the Y electrodes and the address electrodes.

[0052] Since the discharge of the plasma display panel **10** uses only a binary state of ON and OFF, brightness contrast, that is, grayscale is expressed by the number of times of light emission. Thus, a frame is divided into a plurality of subfields. Each subfield is composed of a reset period, an address period, a sustain discharge period (sustain period) and the like. In the reset period, all the discharge cells are set into an initial state, for example, into a state where wall charges are erased irrespective of a light state in a previous subfield. In the address period, selective discharge (address discharge) is performed for determining ON or OFF state of the discharge cells in accordance with the display data, and wall charges for setting the discharge cells into the ON state are selectively formed. In the sustain discharge period, discharge is repeated in the discharge cells in which wall charges are formed by the address discharge to emit a predetermined light. Such driving is controlled by the X electrode drive circuit **20**, the Y electrode drive circuit **30**, the address electrode drive circuit **40**, and the scan circuit **50**.

[0053] Next, an example of a connection form between the plasma display panel and the X and Y electrode drive circuits will be described with reference to **FIG. 2**. **FIG. 2** shows a connection form between the plasma display panel and the X and Y electrode drive circuits.

[0054] The X electrodes (x1 to xn) of the plasma display panel **10** are connected to the X electrode drive circuit **20**

through a printed board **61** and a flexible substrate **62**. The X electrode drive circuit **20** and the printed board **61**, and the printed board **61** and the flexible substrate **62** are connected via connectors **63** and **64**, respectively, and a conductor of the flexible substrate **62** is connected to each X electrode of the plasma display panel **10** by thermocompression or the like. Also, an X electrode pattern **65** for connecting the connector **63** and the connectors **64** is formed on the printed board **61**.

[0055] In particular, the X electrode pattern **65** has a structure in which a current path connecting the center electrodes of the plasma display panel **10** and the X electrode drive circuit **20** is longer than a current path connecting peripheral electrodes and the X electrode drive circuit **20**. More specifically, the current path of this X electrode pattern **65** is formed in a U-shape folded in the upper part (or lower part: shown in **FIG. 3**) in the periphery of the plasma display panel **10**, and is first connected to the electrodes of the upper part (or those of lower part) and then is sequentially connected to the center electrodes via the upper part (or lower part). Thus, in the X electrode pattern **65**, a slit-like cutout **66** is formed on a conductor of the X electrode pattern **65** so that a pair of current paths in the folded U-shape are disposed in parallel and so closely that electromagnetic induction occurs. In other words, the slit-like cutout **66** is formed thin so that conductors at the right and left sides of the cutout **66** generate electromagnetic induction.

[0056] On the other hand, the Y electrodes (y1 to yn) of the plasma display panel **10** are connected to the Y electrode drive circuit **30** through a printed board **71** and a flexible substrate **72** in the same manner as the X electrodes of the plasma display panel **10** and the X electrode drive circuit **20**. The Y electrode drive circuit **30** and the printed board **71**, and the printed board **71** and the flexible substrate **72** are connected via connectors **73** and **74**, respectively, and a conductor of the flexible substrate **72** and each Y electrode of the plasma display panel **10** are connected by thermocompression or the like. Different from the printed board **61** at the X electrode side, the printed board **71** is mounted with the scan circuits **50**. Also, a Y electrode pattern **75** for connecting the connector **73** and the scan circuits **50** is formed and wiring patterns **77** for connecting the scan circuits **50** and the connectors **74** are further formed on the printed board **71**.

[0057] Particularly, similar to the X electrode pattern **65**, the Y electrode pattern **75** also has a structure in which a current path connecting center electrodes of the plasma display panel **10** and the Y electrode drive circuit **30** is longer than a current path connecting peripheral electrodes and the Y electrode drive circuit **30**. More specifically, the current path of this Y electrode pattern **75** is formed in a U-shape folded in the upper part (or lower part) in the periphery of the plasma display panel **10**, and is first connected to the electrodes of the upper part (or those of lower part) and then is sequentially connected to the center electrodes via the upper part (or lower part). Thus, in the Y electrode pattern **75**, a slit-like cutout **76** is formed on a conductor of the Y electrode pattern **75**, and the slit-like cutout **76** is formed thin so that conductors at the right and left sides of the cutout **76** generate electromagnetic induction.

[0058] Next, one example of the connection form between the plasma display panel and the X electrode drive circuit

will be described with reference to **FIG. 3**, in which a current path extending through the upper part of the plasma display panel and a current path extending through the lower part thereof are connected near the center electrodes of the plasma display panel. **FIG. 3** shows a connection form in which the current path extending through the upper part of the plasma display panel and the current path extending through the lower part thereof are connected near the center electrodes.

[0059] The printed board **61** is separated into an upper printed board **61a** and a lower printed board **61b**. An X electrode pattern **65a** serving as a first current path extending through the upper part of the plasma display panel **10** is formed on the upper printed board **61a**, and an X electrode pattern **65b** serving as a second current path extending through the lower part of the plasma display panel **10** is formed on the lower printed board **61b**.

[0060] Similar to the case in **FIG. 2** described above, slit-like cutouts **66a** and **66b** are formed in the X electrode pattern **65a** formed on the upper printed board **61a** and the X electrode pattern **65b** formed on the lower printed board **61a**, respectively. A conductor of the X electrode pattern **65a** extending through the upper part of the plasma display panel **10** and a conductor of the X electrode pattern **65b** extending through the lower part of the plasma display panel **10** are connected near the center electrodes of the plasma display panel **10** via a connector **67**. A part for the connection can be applied to other conductor, a semiconductor device, or a device to be conducted in a high frequency region such as a capacitor other than the connector **67**.

[0061] For example, when the screen size of the plasma display panel **10** is enlarged, one printed board **61** is not enough to form the screen in some cases, and the printed board **61** has to be divided into the upper and lower parts. In this case, as means for connecting the center parts, a conductor such as a connector or a metal fitting is simply used for the connection in some cases. Also, when the X electrode drive circuit **20** and the Y electrode drive circuit **30** are divided into the upper and lower parts and operate separately in the period other than the sustain period as described later, the connection therebetween is required in the sustain period, and a semiconductor device or a capacitor to be conducted in a high frequency region is used in such a case.

[0062] Though not shown, also in the connection form between the plasma display panel **10** and the Y electrode drive circuit **30**, a conductor of the Y electrode pattern serving as a first current path extending through the upper part of the plasma display panel **10** and a conductor of the Y electrode pattern serving as a second current path extending through the lower part of the plasma display panel **10** are connected near the center electrodes of the plasma display panel **10** via a connector.

[0063] Next, another example of the connection form between the plasma display panel and the X electrode drive circuit will be described with reference to **FIG. 4** and **FIG. 5**, in which a pair of current paths in the folded U-shape are disposed. **FIG. 4** shows a connection form in which adjacent layers of a multilayer substrate are used to closely dispose a pair of current paths. **FIG. 5** shows a connection form in which different types of substrates are attached together so as to closely dispose a pair of current paths.

[0064] In FIG. 4, a printed board 61c is made of a multilayer substrate having several layers. In this printed board 61c, one X electrode pattern 65c, which forms a pair of current paths together with the connector 63 for the X electrode drive circuit 20 and the connectors 64 for the flexible substrate 62, is formed on an insulator of the first layer and the other X electrode pattern 65d is formed on an insulator of the second layer. The X electrode patterns 65c and 65d of the first layer and second layer are partially connected via through holes 68. Thus, a structure in which a pair of current paths in the folded U-shape are closely disposed is formed in the adjacent layers of the first and second layers in the printed board 61c.

[0065] FIG. 5 shows a structure composed of different types of substrates, in which a flexible substrate 62a and a printed board 61d are attached to each other. In this structure, one X electrode pattern 65e which forms a pair of current paths is formed on the flexible substrate 62a connected to the X electrodes of the plasma display panel 10, and the other X electrode pattern 65f is formed on an insulator of the printed board 61d on which the connector 63 for the X electrode drive circuit 20 is mounted. Also, the X electrode patterns 65e and 65f of the flexible substrate 62a and the printed board 61d are partially connected through a conductive material such as solder filled in conductive lands 68a. Thus, in the structure in which different types of substrates such as the flexible substrate 62a and the printed board 61d are attached to each other, a pair of current paths in the folded U-shape are closely disposed.

[0066] Though not shown, also in the connection form between the plasma display panel 10 and the Y electrode drive circuit 30, a pair of current paths in the folded U-shape are closely disposed in the adjacent layers of the first and second layers of the printed board or in the structure in which different types of substrates such as the flexible substrate and printed board are attached to each other.

[0067] Next, another example of the connection form between the plasma display panel and the X electrode drive circuit will be described with reference to FIG. 6, in which a common electrode portion connected at an end face of the plasma display panel is used in place of the connection portion in the folded U-shape at the plasma display panel side. FIG. 6 shows a connection form in which a common electrode portion connected at an end face of the plasma display panel is used in place of the connection portion in the folded U-shape at the plasma display panel side.

[0068] The plasma display panel 10 is provided with a common electrode portion 11 in which a plurality of X electrodes are connected at an end face of the plasma display panel 10, and the common electrode portion 11 is used in place of the connection portion in the folded U-shape at the plasma display panel 10 side. Thus, the common electrode portion 11 on the plasma display panel 10 and an X electrode pattern 65g on the printed board 61e can be connected by the flexible substrate 62b and a pair of current paths in the folded U-shape can be formed without forming a slit-like cutout in the printed board 61e. Also in this case, it is desirable that the pair of current paths are closely disposed.

[0069] Next, one example in which the X electrode drive circuit for driving the X electrodes and the Y electrode drive circuit for driving the Y electrodes of the plasma display panel are separated into several parts will be described with reference to FIG. 7. FIG. 7 shows a connection form between the plasma display panel and the X and Y electrode drive circuits in an odd/even separation structure as one example of the separation.

[0070] In the structure in which a plurality of X electrodes and Y electrodes of the plasma display panel 10 are separated into odd-numbered electrodes (x1, x3, . . . , xn-1 and y1, y3, . . . , yn-1) and even-numbered electrodes (x2, x4, . . . , xn, and y2, y4, . . . , yn), two X electrode drive circuits 20a and 20b and two Y electrode drive circuits 30a and 30b are provided for the odd-numbered electrodes and the even-numbered electrodes. Further, also in the printed boards 61f and 71a, the X electrode pattern 65 and the Y electrode pattern 75 are separated into those for the odd-numbered electrodes and the even-numbered electrodes and are formed in different layers. For example, in FIG. 7, an X electrode pattern 65h and a Y electrode pattern 75a for the odd-numbered electrodes are formed on the front surface (shown by solid lines) and an X electrode pattern 65i and a Y electrode pattern 75b for the even-numbered electrodes are formed on the rear surface (shown by dashed lines).

[0071] Similarly, also in the flexible substrates 62c and 72a, wiring patterns for the odd-numbered electrodes are formed on the front surface (shown by solid lines) and wiring patterns for the even-numbered electrodes are formed on the rear surface (shown by dashed lines).

[0072] Also in this structure, similar to FIG. 2, the current paths by the X electrode patterns 65h and 65i and the current paths by the Y electrode pattern 75a and 75b are formed in the U-shape folded in the periphery of the plasma display panel 10. Therefore, the X electrode patterns 65h and 65i and the Y electrode patterns 75a and 75b have slit-like cutouts 66c, 66d, 76a and 76b formed on the conductors of each electrode pattern, and conductors at the right and left sides of the cutouts 66c, 66d, 76a, and 76b are formed so closely that electromagnetic induction occurs.

[0073] Next, another example of the connection form between the plasma display panel and the X electrode drive circuit will be described with reference to FIG. 8, in which an output portion of the X electrode drive circuit is separated into the upper part and the lower part and a current path extending through the upper part of the plasma display panel and a current path extending through the lower part thereof are connected near the center electrodes. FIG. 8 shows a connection form in which the output portion of the X electrode drive circuit is separated into an upper part and a lower part and the current path extending through the upper part and the current path extending through the lower part are connected near the center electrodes.

[0074] In the structure in which the output portion of the X electrode drive circuit 20c is separated into the upper part and the lower part, the X electrode pattern 65 of the printed board 61g is formed to be separated into the upper part and the lower part. Also in this structure, an upper X electrode pattern 65j and a lower X electrode pattern 65k have slit-like cutouts 66e and 66f formed on a conductor of each electrode pattern, and the conductors at the right and left sides of the cutouts 66e and 66f are formed so closely that electromagnetic induction occurs. Further, the conductor of the upper X electrode pattern 65j and the conductor of the lower X electrode pattern 65k are connected near the center electrodes of the plasma display panel 10 via a semiconductor device 69.

[0075] Though not shown, also in a connection form between the plasma display panel 10 and the Y electrode drive circuit 30, a conductor of an upper Y electrode pattern and a conductor of a lower Y electrode pattern are connected near the center electrodes of the plasma display panel 10 via a semiconductor device.

[0076] Effects shown in FIG. 9 to FIG. 11 can be obtained from the plasma display device according to the present embodiment described above. FIG. 9 shows a parasitic inductance distribution (FIG. 9A) and a luminance distribution (FIG. 9B) when the current path in the X electrode pattern (also the current path in the Y electrode pattern) has a U-shape folded in the periphery of the plasma display panel. FIG. 10 shows a parasitic inductance distribution (FIG. 10A) and a luminance distribution (FIG. 10B) when a pair of current paths in the folded U-shape are disposed in parallel and so closely that electromagnetic induction occurs. FIG. 11 shows a parasitic inductance distribution (FIG. 11A) and a luminance distribution (FIG. 11B) when flexible substrates are discretely connected.

[0077] As shown in FIG. 9, when the current path in the X electrode pattern (also the current path in the Y electrode pattern) is formed in the U-shape folded in the periphery of the plasma display panel 10, in the luminance distribution determined by the parasitic inductance distribution, the center of the plasma display panel 10 has the luminance corresponding to  $L_0+L_1$  and the upper and lower parts of the plasma display panel 10 have the luminance corresponding to  $L_0+0.75 \times L_1$ . Accordingly, a luminance difference between the center and the upper and lower parts can be suppressed to that corresponding to a deviation by  $0.25 \times L_1$ . When comparing this luminance distribution with that of a conventional structure in FIG. 17, a luminance at the center of the plasma display panel 10 is increased from  $L_0$  to  $L_0+L_1$  and a luminance in the upper and lower parts of the plasma display panel 10 is decreased from  $L_0+L_1$  to  $L_0+0.75 \times L_1$ . As a result, a luminance deviation between the center and the upper and lower parts can be reduced from  $L_1$  to  $0.25 \times L_1$ .

[0078] A basis of each value 0.75 and 0.25 is as follows. That is, with respect to the inductance from the X electrode drive circuit 20 and the Y electrode drive circuit 30, in the current paths extending from a brunch point between upper and lower paths to the center through the upper part and the lower part, respectively, the inductance of the upper path is twice the inductance  $L_1$  ( $L_1 \times 2$ ) because the path goes to and from the upper part. Since the inductance is combined with the inductance of the lower path ( $L_1 \times 2$ ), the inductance becomes  $L_1$  ( $(L_1 \times 2) \times \frac{1}{2} = L_1$ ). Next, in the paths from the brunch point between upper and lower paths to the upper part, the inductance of the shortest path ( $L_1$ ) and an inductance through the lower part ( $L_1 \times 3$ ) are combined, and the inductance becomes  $0.75 \times L_1$  ( $L_1 \times (3 \times L_1) / (L_1 + (3 \times L_1)) = 0.75 \times L_1$ ). Therefore, a deviation between the center and the upper and lower parts is defined as  $0.25 \times L_1$  ( $L_1 - 0.75 \times L_1 = 0.25 \times L_1$ ).

[0079] As shown in FIG. 10, when a pair of current paths in the folded U-shape are disposed in parallel and so closely that electromagnetic induction occurs, in comparison with the case where they are in the simply folded U-shape, a luminance at the center of the plasma display panel 10 can be decreased from  $L_0+L_1$  by reducing  $L_1$  and a luminance in the upper and lower parts of the plasma display panel 10 can be decreased from  $L_0+0.75 \times L_1$  by reducing  $0.75 \times L_1$ . As a result, it is possible to reduce the luminance deviation between the center and the upper and lower parts to be smaller than  $0.25 \times L_1$ . This is because, since the inductance of the connecting means 60 (70) can be reduced by the close disposition of in-phase and bidirectional current in the current paths, the luminance deviation between the center and the upper and lower parts of the screen can be reduced.

[0080] As shown in FIG. 11, when the flexible substrates are discretely connected, in comparison with a conventional structure of FIG. 18, the luminance at the center of the plasma display panel 10 is increased from  $L_0$  to  $L_0+L_1$  and the luminance at the upper and lower parts of the plasma display panel 10 is decreased from  $L_0+L_1$  to  $L_0+0.75 \times L_1$ . As a result, it is possible to alleviate the luminance deviation between the center and the upper and lower parts (a dashed line in the luminance distribution is that of FIG. 9B).

[0081] Therefore, according to the plasma display device of the present embodiment, it is possible to achieve the increase in the luminance at the center of the screen, while suppressing an inductance deviation and reducing a luminance difference in the entire screen below a permissible value. In particular, the plasma display device is further preferable in the case where the flexible substrates for the X electrodes and the Y electrodes are separately provided along with enlargement of the screen size of the plasma display panel 10.

[0082] In the foregoing, the invention made by the inventors of the present invention has been concretely described based on the embodiments. However, it is needless to say that the present invention is not limited to the foregoing embodiments and various modifications and alterations can be made within the scope of the present invention.

[0083] The present invention relates to a technology for the plasma display device and is applied to a connection structure between the X/Y electrodes and the X/Y electrode drive circuits in the plasma display panel. In particular, it is effectively applied to the case where the flexible substrates for the X electrode and the Y electrodes are separately provided along with enlargement in the screen size of the plasma display panel.

What is claimed is:

1. A plasma display device comprising: a plasma display panel; an X electrode drive circuit for driving a plurality of X electrodes of said plasma display panel; a Y electrode drive circuit for driving a plurality of Y electrodes of said plasma display panel; and an address electrode drive circuit for driving a plurality of address electrodes of said plasma display panel,

wherein said plasma display device further comprises: connecting means for connecting each X electrode of said plasma display panel and said X electrode drive circuit and connecting each Y electrode of said plasma display panel and said Y electrode drive circuit, respectively, and

said connecting means has a structure in which a current path connecting center electrodes of said plasma display panel and said X electrode drive circuit or Y electrode drive circuit is longer than a current path connecting peripheral electrodes of said plasma display panel and said X electrode drive circuit or Y electrode drive circuit.

2. The plasma display device according to claim 1,

wherein current paths at the plasma display panel side of said connecting means are in a U-shape folded in the upper part and the lower part in the periphery of said plasma display panel, respectively, and

said current paths are first connected to the upper electrodes and lower electrodes of said plasma display panel, respectively, extend through an upper part and a



lower part, and then sequentially connected to the center electrodes of said plasma display panel.

**3.** The plasma display device according to claim 2, wherein a first current path extending through the upper part of said plasma display panel and a second current path extending through the lower part of said plasma display panel are connected near the center electrodes of said plasma display panel.

**4.** The plasma display device according to claim 3, wherein a pair of current paths in the folded U-shape are disposed so closely that electromagnetic induction occurs.

**5.** The plasma display device according to claim 4, wherein a common electrode portion in which a plurality of X electrodes disposed on said plasma display panel are connected at an end face of said plasma display panel is used in place of the connection portion in the folded U-shape at the plasma display panel side.

**6.** The plasma display device according to claim 4, wherein, as a method of closely disposing said pair of current paths, a slit-like cutout is formed on a conductor so that the current paths are disposed in parallel.

**7.** The plasma display device according to claim 4, wherein, as a method of closely disposing said pair of current paths, adjacent layers of a multilayer substrate are used.

**8.** The plasma display device according to claim 4, wherein, as a method of closely disposing said pair of current paths, different types of substrates are attached to each other.

**9.** The plasma display device according to claim 3, wherein means for connecting said first current path and said second current path is a conductor, a semiconductor device or a device to be conducted in a high frequency region such as a capacitor.

**10.** The plasma display device according to claim 2, wherein said connecting means and said plurality of X electrodes and Y electrodes are connected via a semiconductor device, respectively.

**11.** The plasma display device according to claim 3, wherein said connecting means and said plurality of X electrodes and Y electrodes are connected via a semiconductor device, respectively.

**12.** The plasma display device according to claim 4, wherein said connecting means and said plurality of X electrodes and Y electrodes are connected via a semiconductor device, respectively.

**13.** The plasma display device according to claim 5, wherein said connecting means and said plurality of X electrodes and Y electrodes are connected via a semiconductor device, respectively.

**14.** The plasma display device according to claim 6, wherein said connecting means and said plurality of X electrodes and Y electrodes are connected via a semiconductor device, respectively.

**15.** The plasma display device according to claim 7, wherein said connecting means and said plurality of X electrodes and Y electrodes are connected via a semiconductor device, respectively.

**16.** The plasma display device according to claim 8, wherein said connecting means and said plurality of X electrodes and Y electrodes are connected via a semiconductor device, respectively.

**17.** The plasma display device according to claim 9, wherein said connecting means and said plurality of X electrodes and Y electrodes are connected via a semiconductor device, respectively.

**18.** The plasma display device according to claim 2, wherein a pair of current paths in the folded U-shape are disposed so closely that electromagnetic induction occurs.

**19.** The plasma display device according to claim 2, wherein a common electrode portion in which a plurality of X electrodes disposed on said plasma display panel are connected at an end face of said plasma display panel is used in place of the connection portion in the folded U-shape at the plasma display panel side.

**20.** The plasma display device according to claim 3, wherein a common electrode portion in which a plurality of X electrodes disposed on said plasma display panel are connected at an end face of said plasma display panel is used in place of the connection portion in the folded U-shape at the plasma display panel side.

\* \* \* \* \*