



(19) **United States**

(12) **Patent Application Publication**
MATOS

(10) **Pub. No.: US 2019/0233132 A1**

(43) **Pub. Date: Aug. 1, 2019**

(54) **SYSTEMS AND METHODS FOR DETECTING AND MANAGING THE UNAUTHORIZED USE OF AN UNMANNED AIRCRAFT**

G06K 9/00 (2006.01)
B64C 39/02 (2006.01)
G05D 1/00 (2006.01)
G05D 1/04 (2006.01)
G05D 1/08 (2006.01)

(71) Applicant: **JEFFREY A. MATOS**, NEW ROCHELLE, NY (US)

(52) **U.S. Cl.**

(72) Inventor: **JEFFREY A. MATOS**, NEW ROCHELLE, NY (US)

CPC .. *B64D 45/0015* (2013.01); *B64D 2045/0055* (2013.01); *G08G 5/003* (2013.01); *G08G 5/006* (2013.01); *G08G 5/0056* (2013.01); *G08G 5/0052* (2013.01); *G08G 5/0034* (2013.01); *G08G 5/0026* (2013.01); *G08G 5/0021* (2013.01); *G08G 5/0013* (2013.01); *G08G 5/0008* (2013.01); *H04W 48/02* (2013.01); *G06K 9/00* (2013.01); *G08G 5/0069* (2013.01); *B64C 39/024* (2013.01); *G05D 1/0022* (2013.01); *G05D 1/042* (2013.01); *G05D 1/0808* (2013.01); *B64C 2201/146* (2013.01); *G08C 2201/61* (2013.01); *G08G 5/0078* (2013.01)

(21) Appl. No.: **16/199,881**

(22) Filed: **Nov. 26, 2018**

Related U.S. Application Data

(63) Continuation of application No. 14/331,415, filed on Jul. 15, 2014, now Pat. No. 10,138,000, which is a continuation of application No. 13/195,268, filed on Aug. 1, 2011, now Pat. No. 8,788,118, which is a continuation-in-part of application No. 12/946,254, filed on Nov. 15, 2010, now Pat. No. 7,991,517, which is a continuation of application No. 11/899,827, filed on Sep. 6, 2007, now Pat. No. 7,835,824.

(60) Provisional application No. 60/842,600, filed on Sep. 6, 2006.

Publication Classification

(51) **Int. Cl.**

B64D 45/00 (2006.01)
G08G 5/00 (2006.01)
H04W 48/02 (2006.01)

(57)

ABSTRACT

A method for policing and managing the operation of a flying, unmanned aircraft in the event of usurpation of control of, malfunction of, or ill-intentioned use of, this aircraft includes the steps of (a) detecting inappropriate operation of the aircraft; (b) transmitting a takeover command to the aircraft to interrupt control of the operation of this aircraft by a first pilot and relinquish control of the aircraft to a second pilot; and (c) transmitting control commands to the aircraft to control its operation by the second pilot, until the need for alternate pilot control of the aircraft has ended or until the aircraft has landed safely.

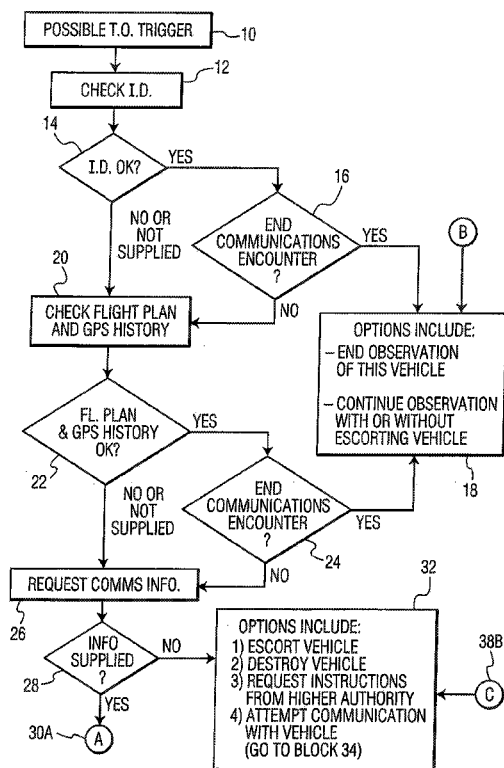

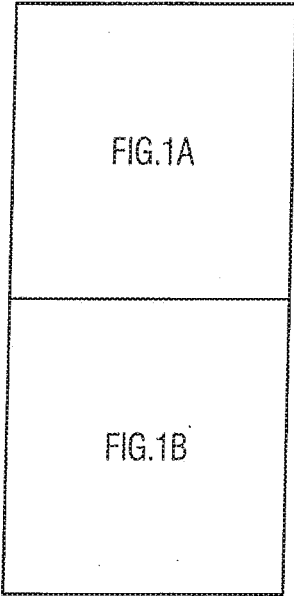

FIG. 1

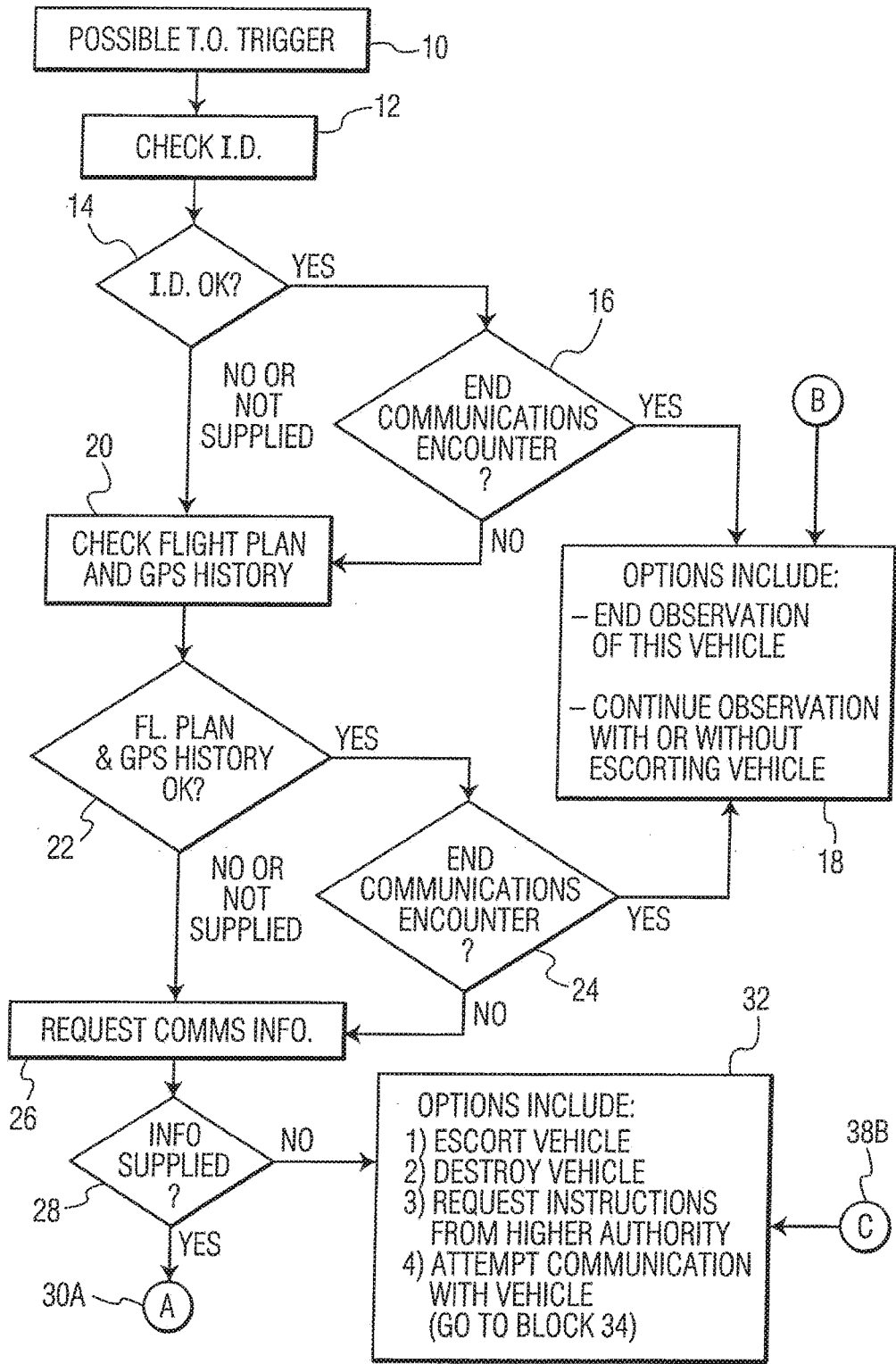

FIG. 1A

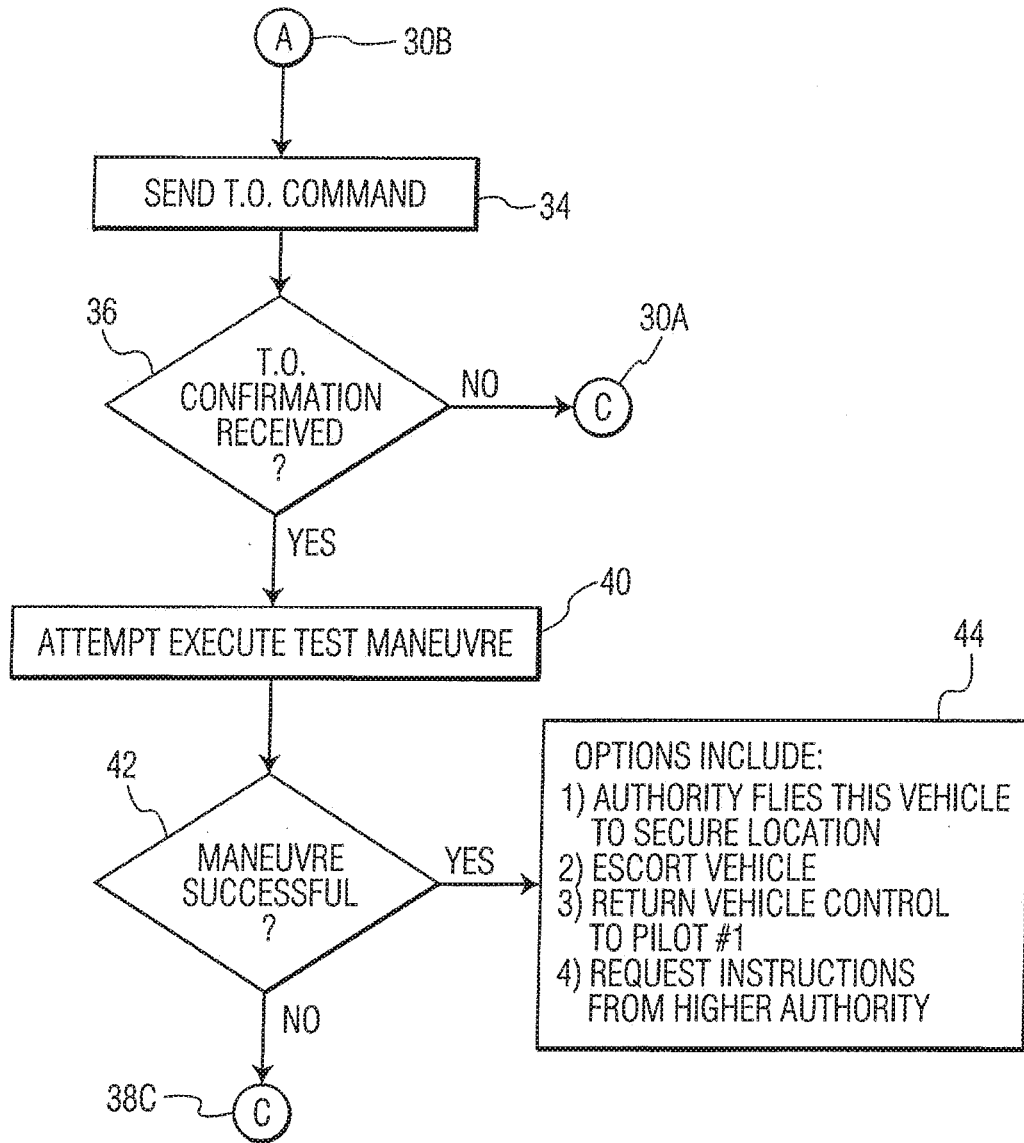

FIG. 1B

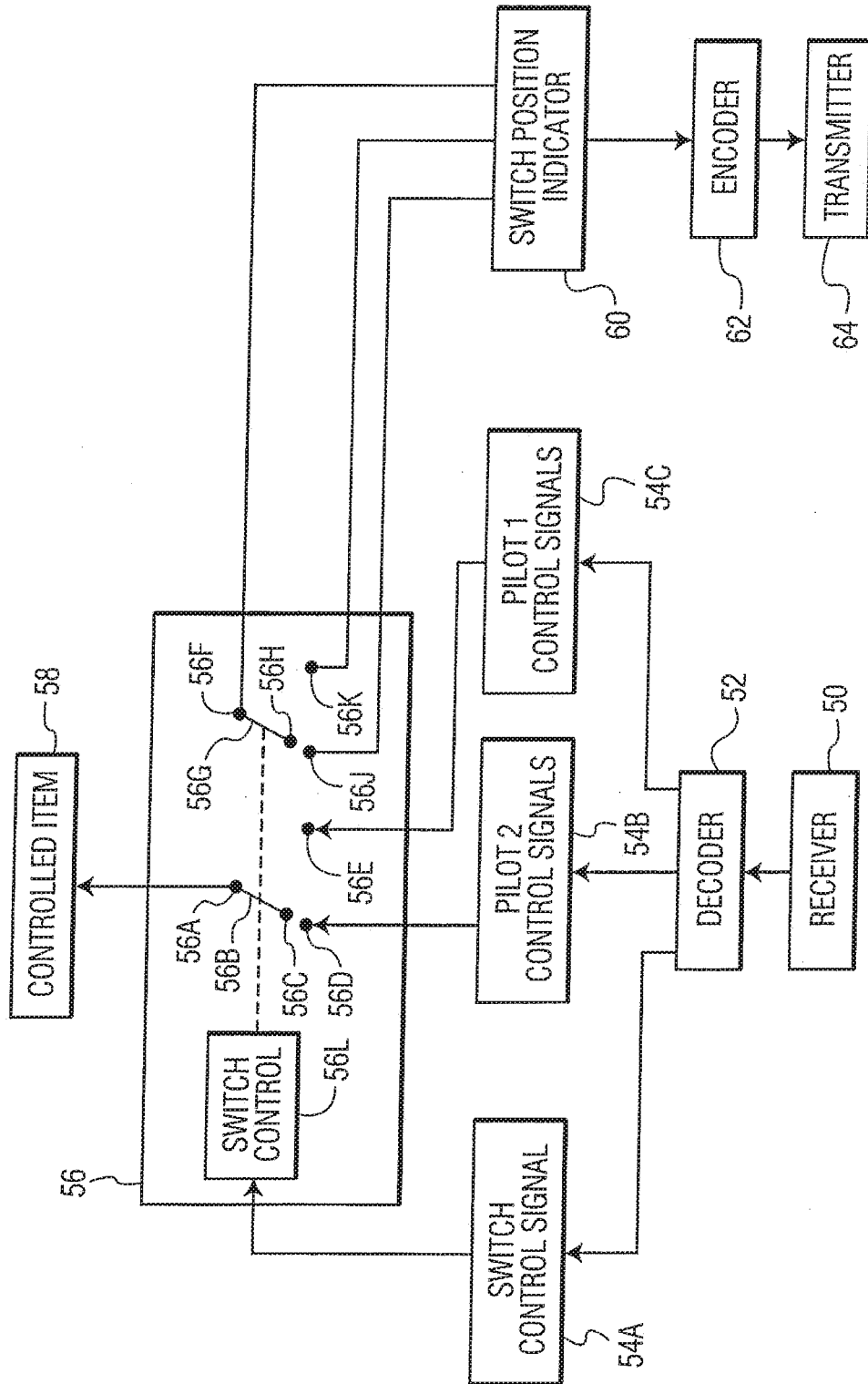

FIG. 2

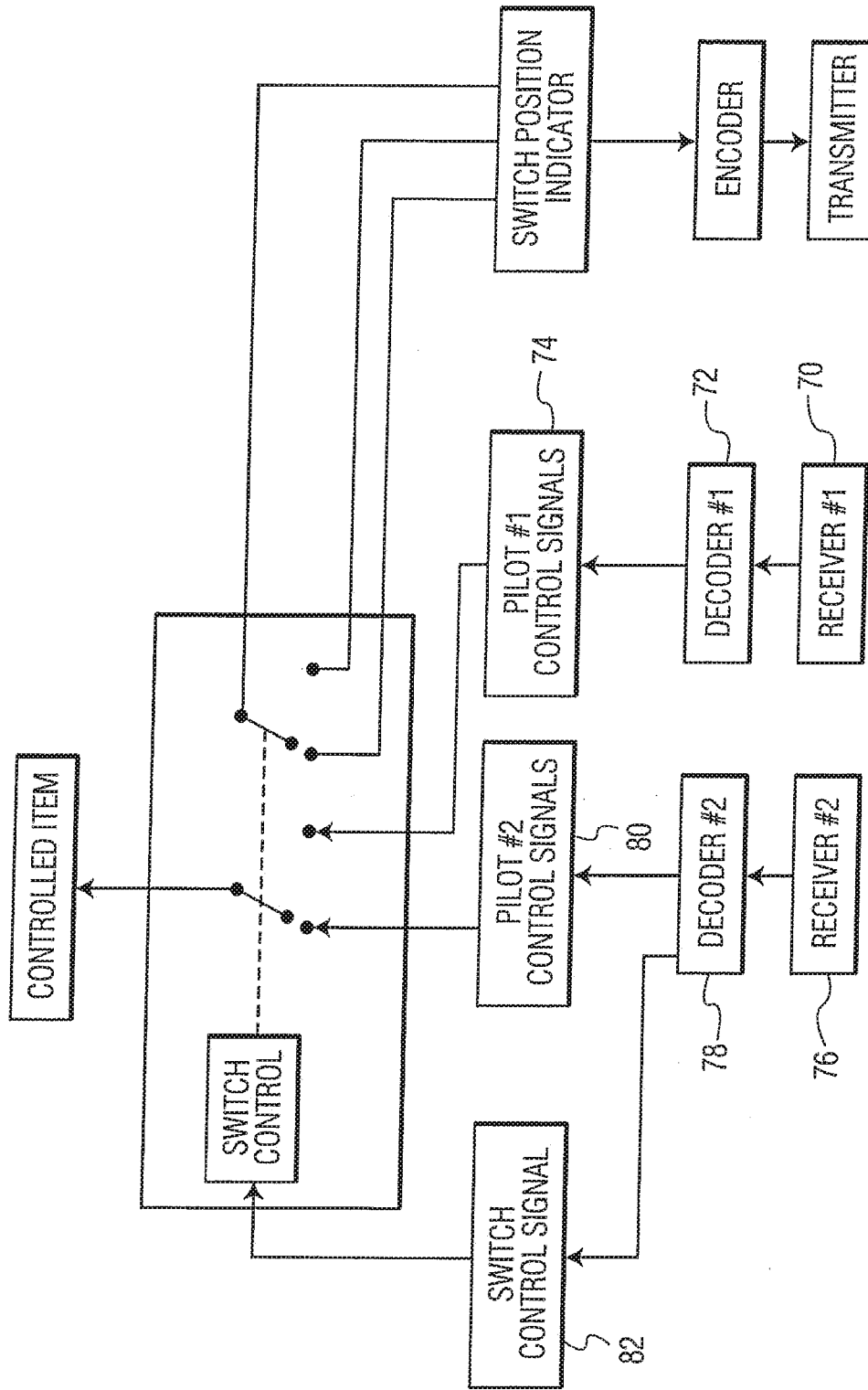

FIG. 3

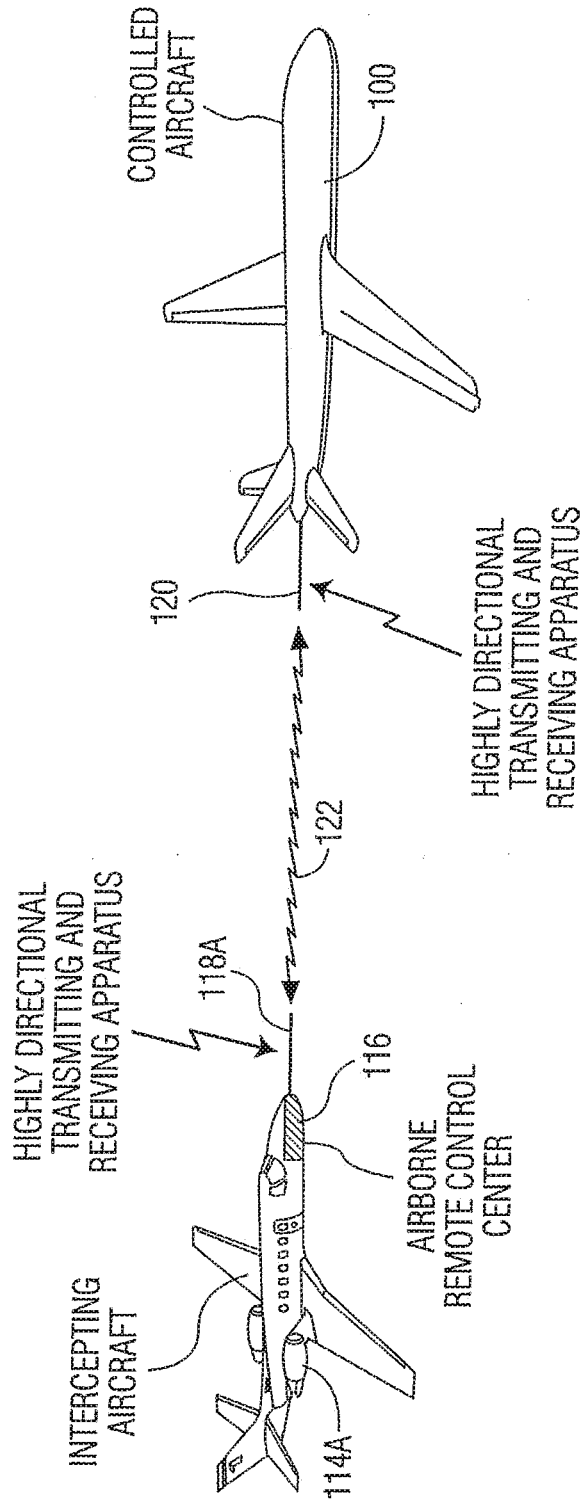

FIG. 4

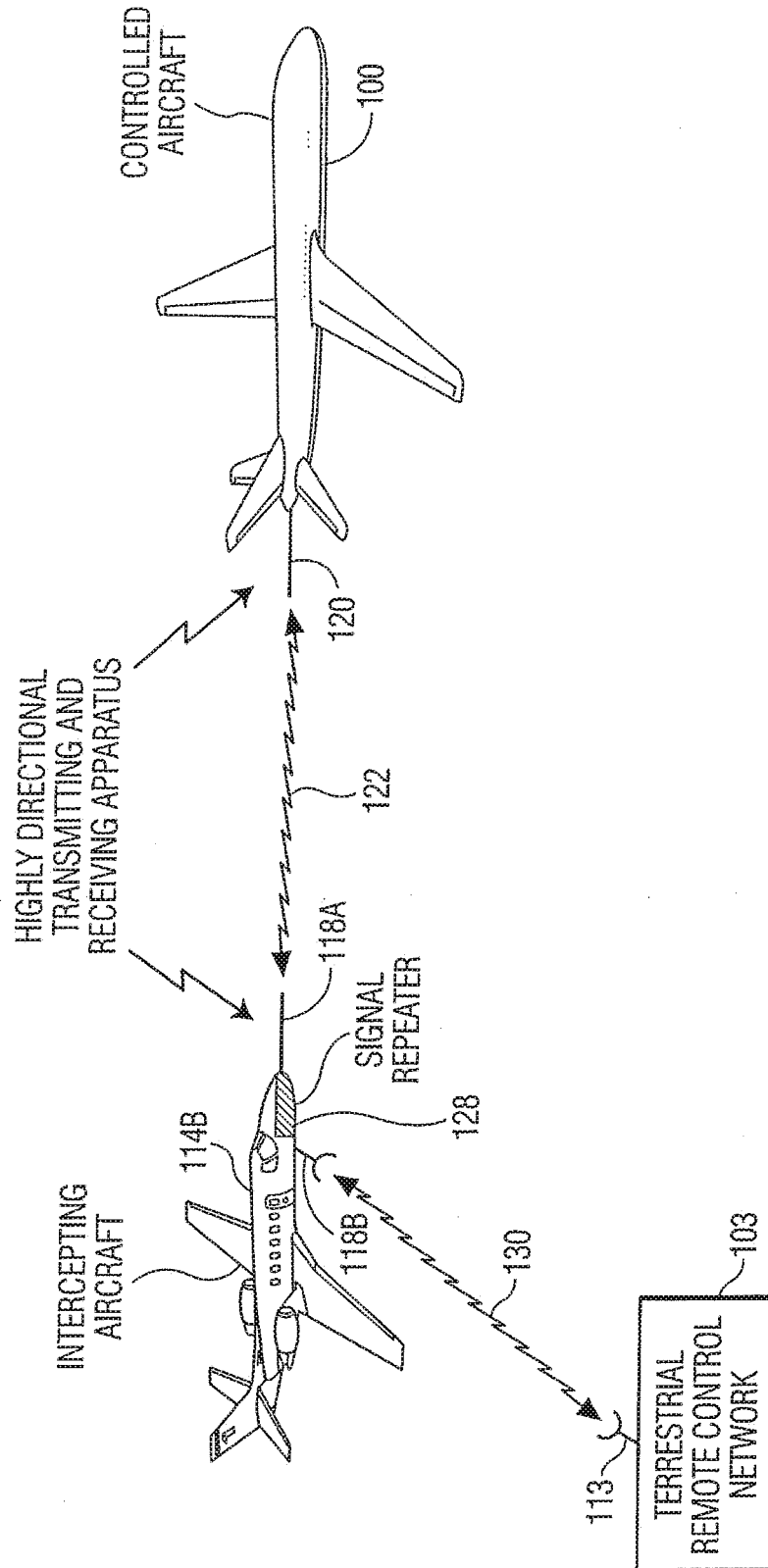

FIG. 5

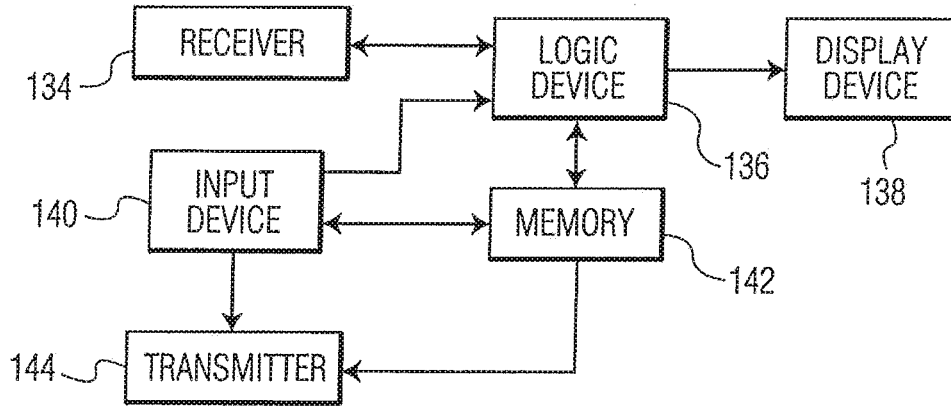

FIG. 6

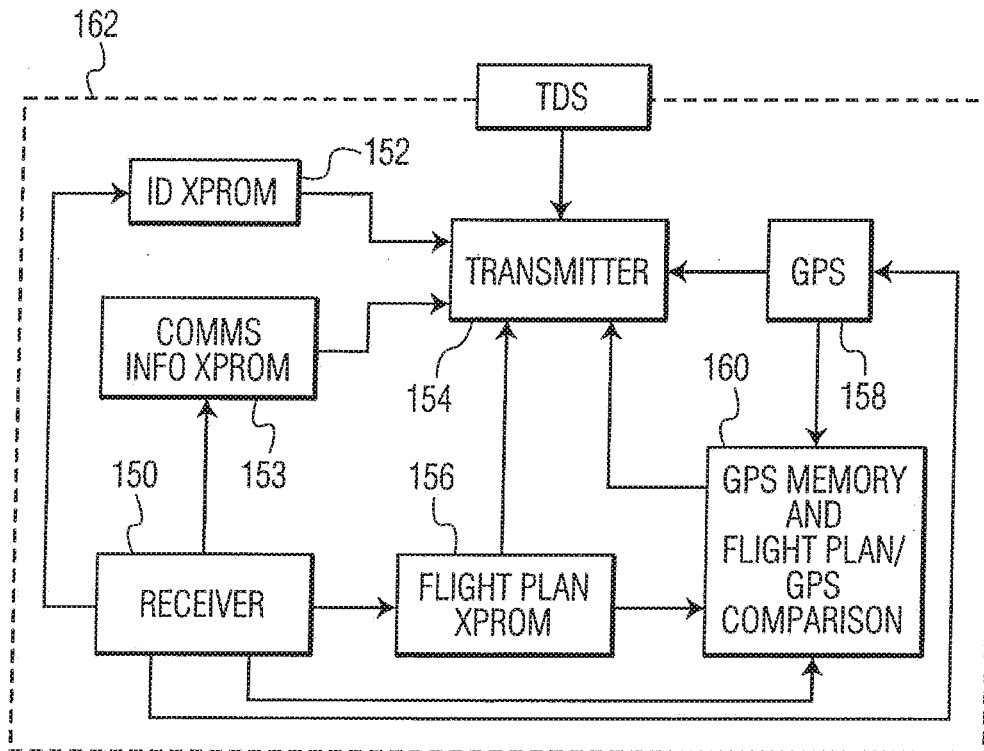

FIG. 7

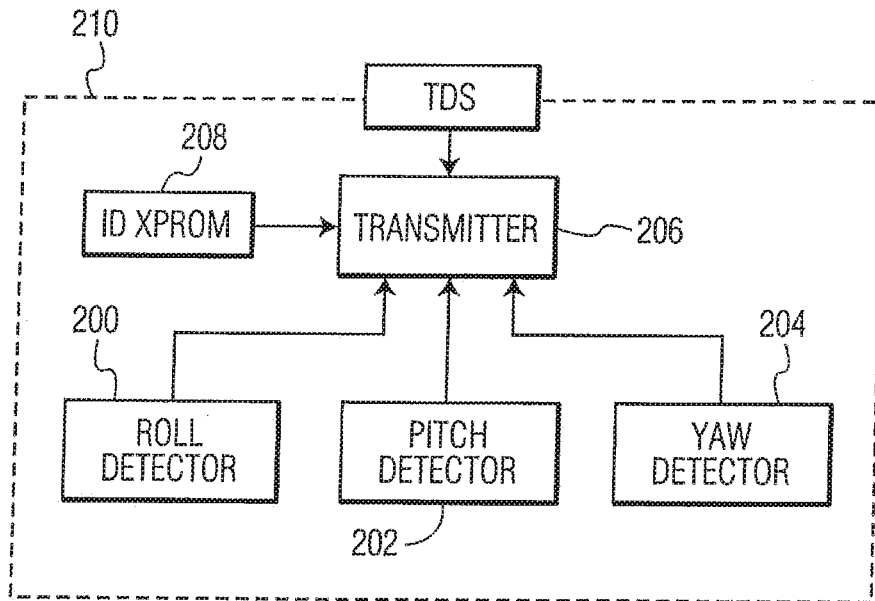

FIG. 8

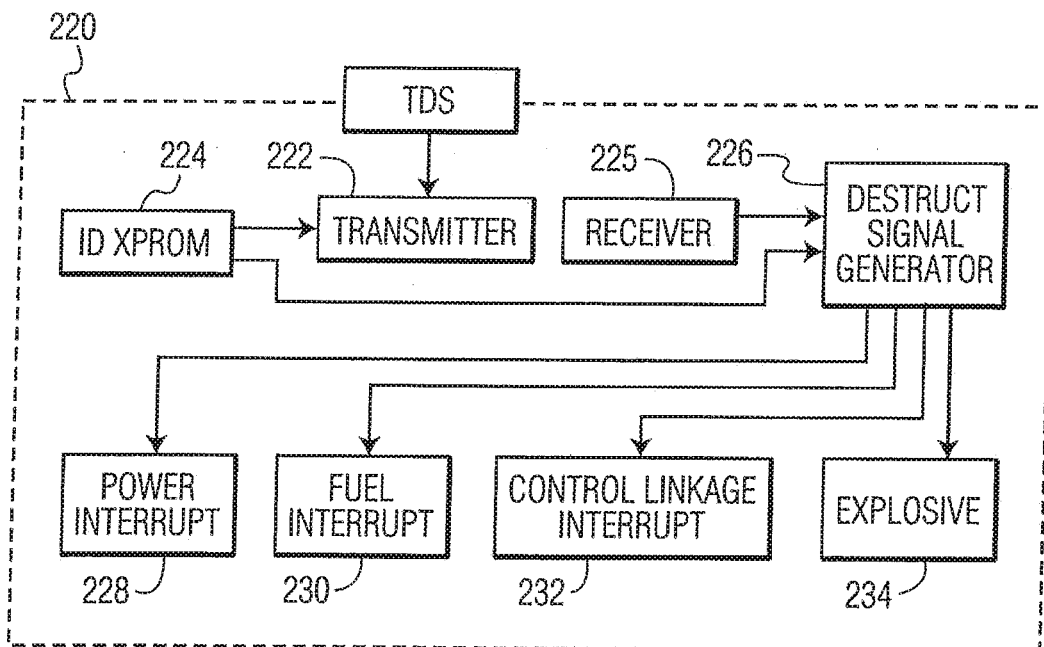

FIG. 9

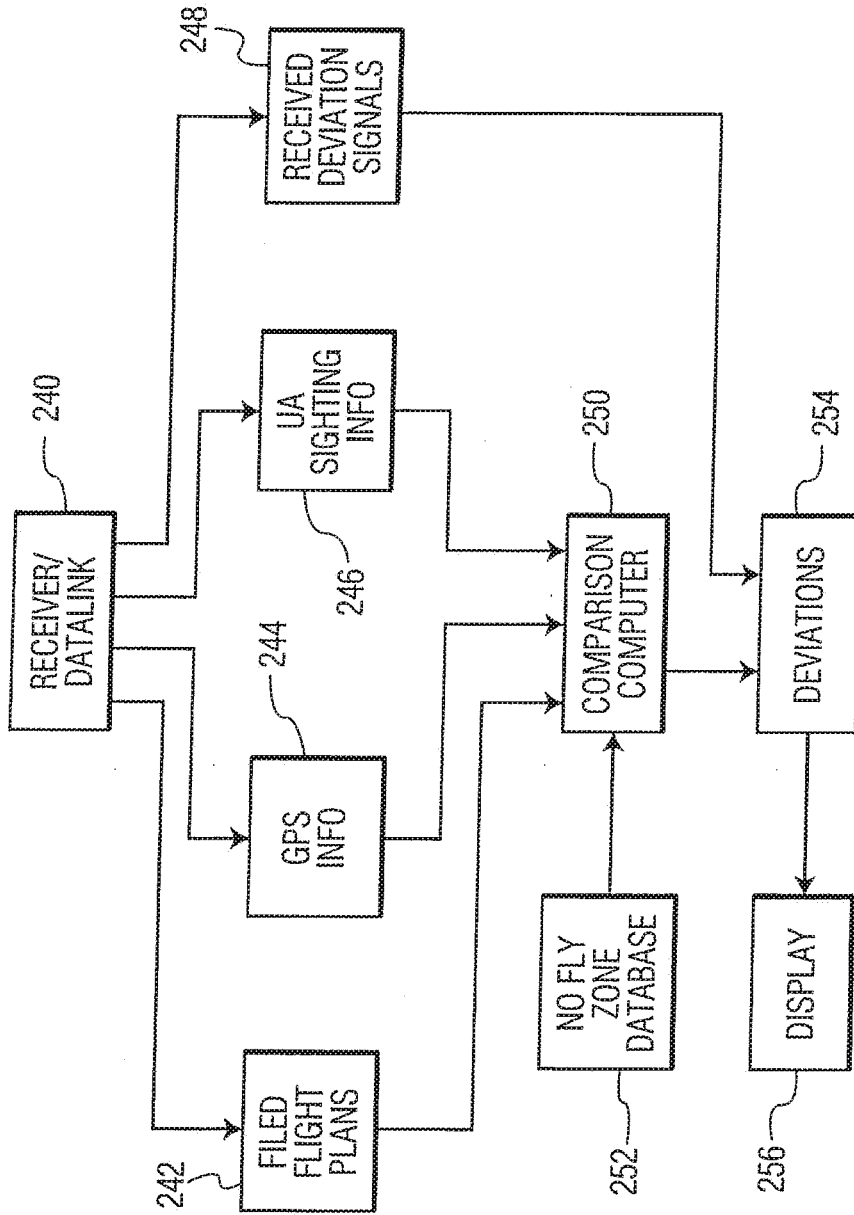

FIG. 10

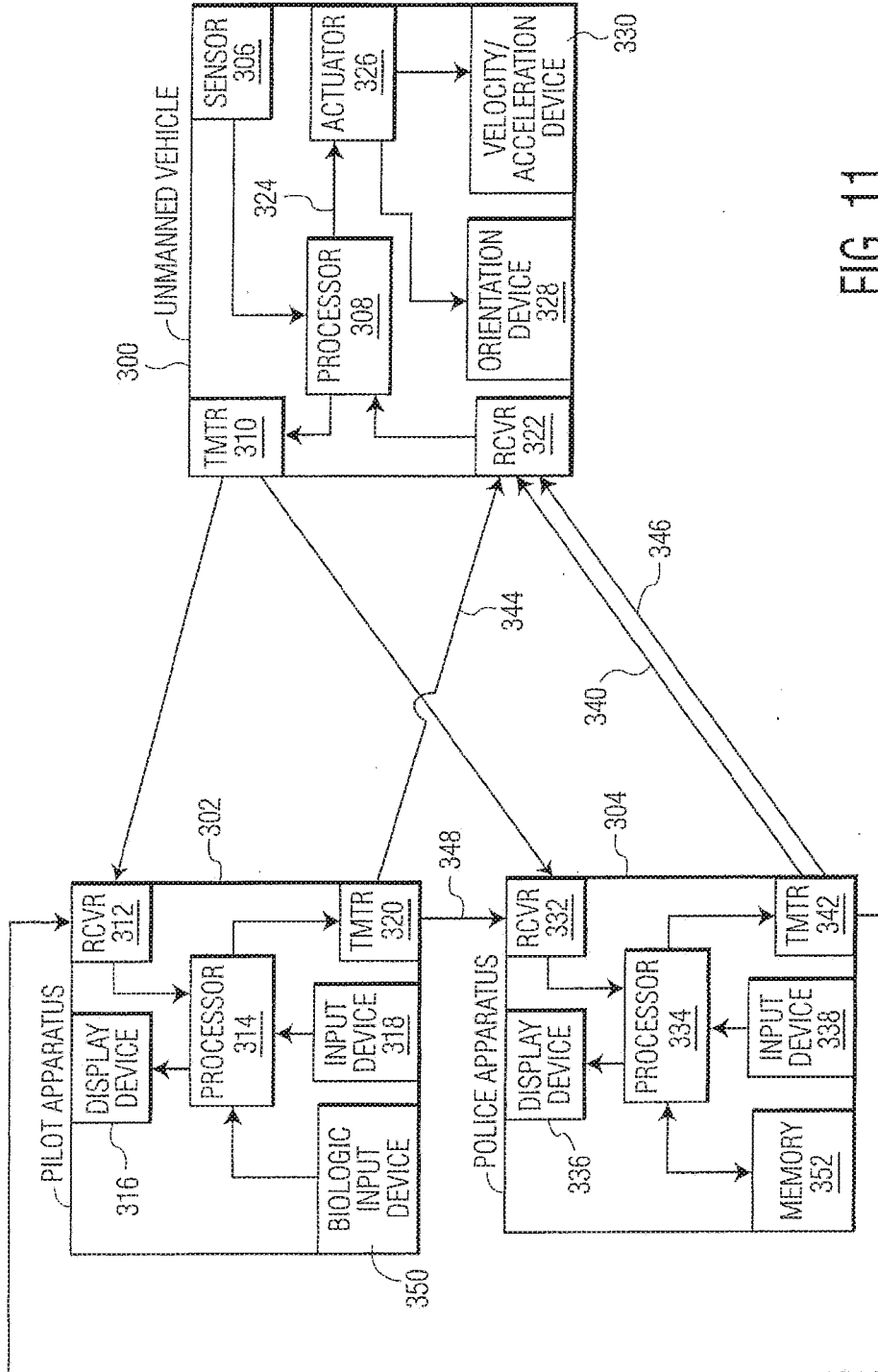

FIG. 11

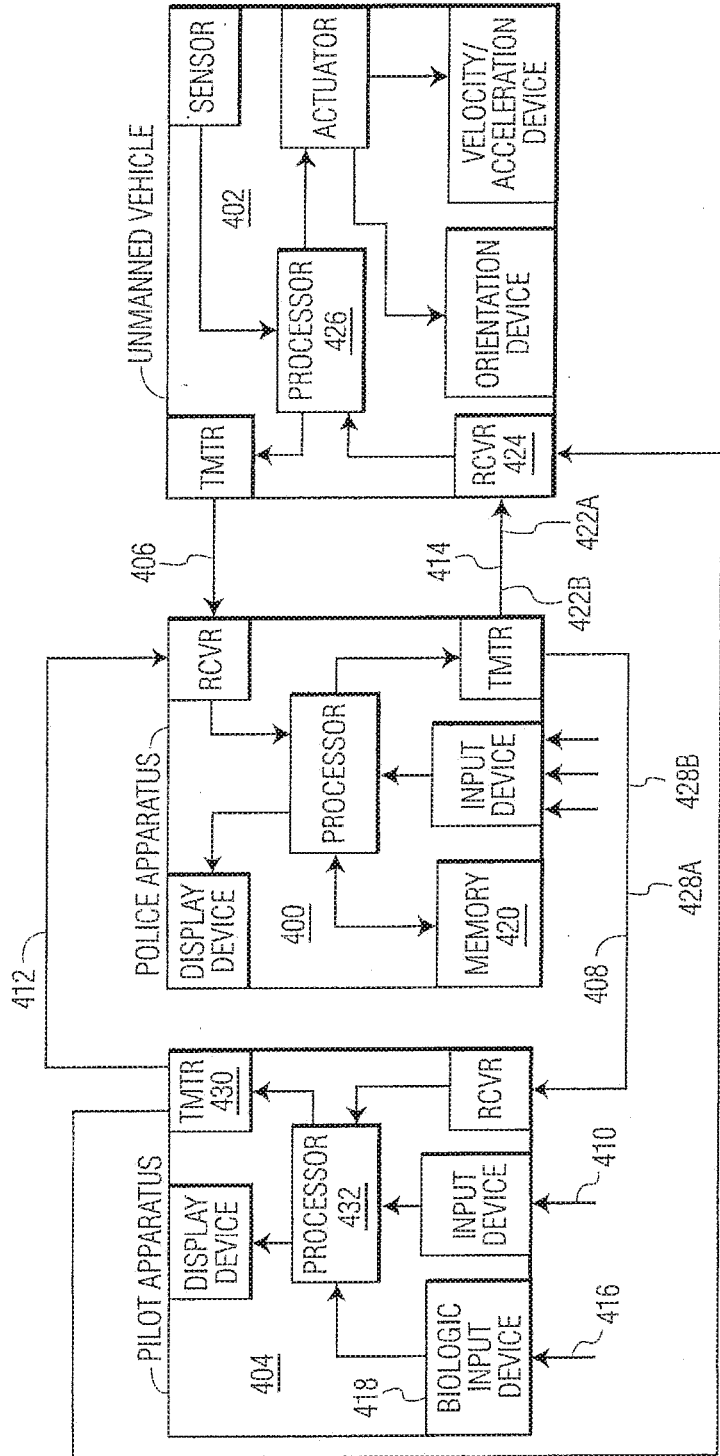

FIG. 12

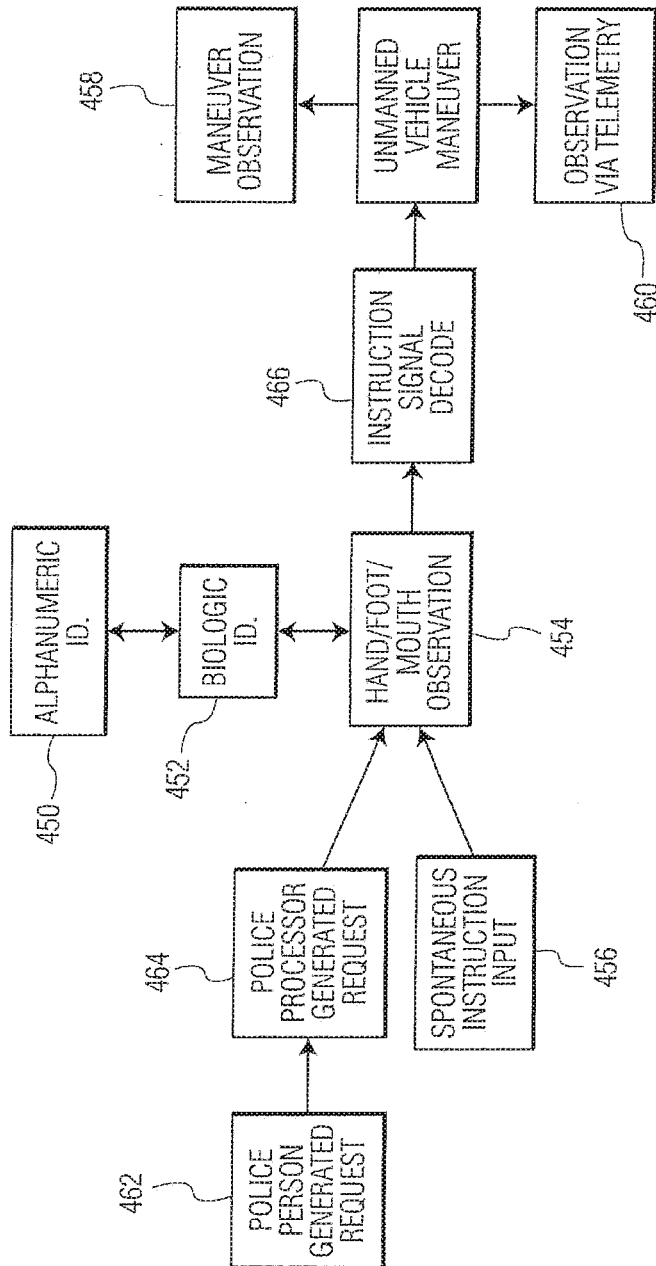

FIG. 13

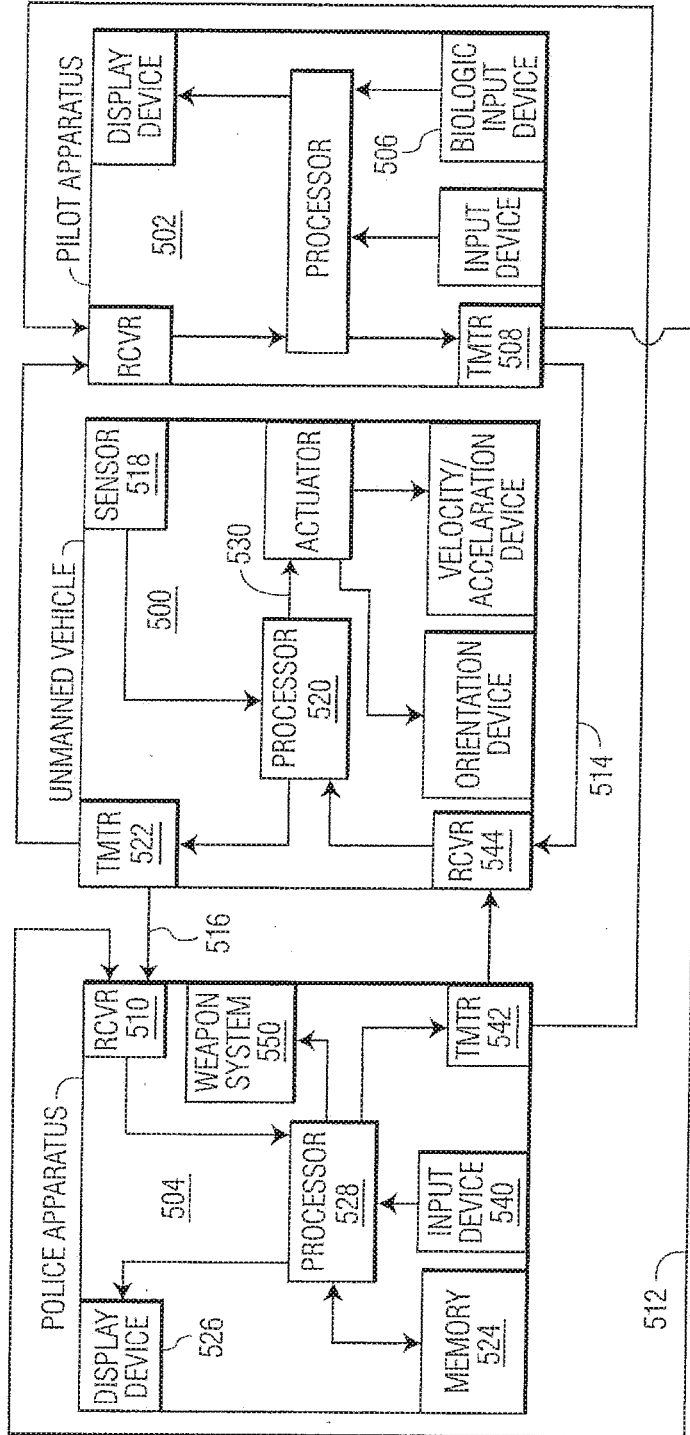

FIG. 14

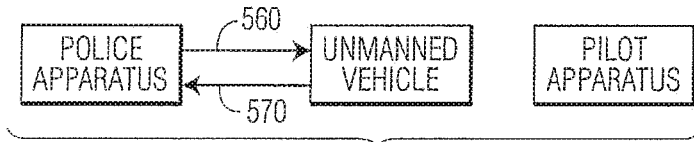

FIG. 15A

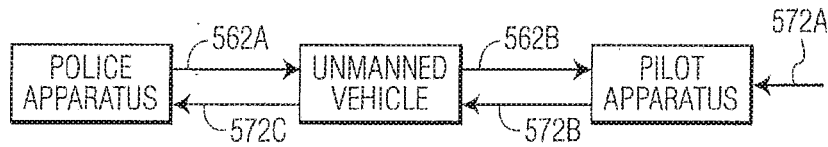

FIG. 15B

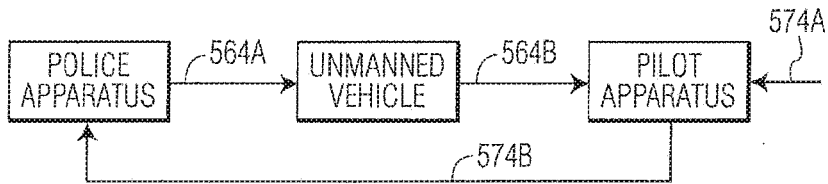

FIG. 15C

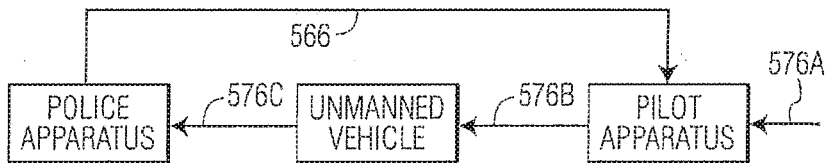

FIG. 15D

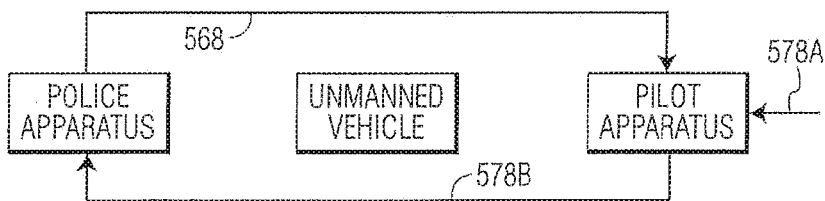

FIG. 15E

**SYSTEMS AND METHODS FOR DETECTING
AND MANAGING THE UNAUTHORIZED
USE OF AN UNMANNED AIRCRAFT**

CROSS-REFERENCE TO RELATED
APPLICATIONS

[0001] This application is a continuation of U.S. patent application Ser. No. 14/331,415, filed on Jul. 15, 2014, which in turn is a continuation of U.S. patent application Ser. No. 13/195,268, filed Aug. 1, 2011 (now U.S. Pat. No. 8,788,118), which in turn is a continuation-in-part of U.S. patent application Ser. No. 12/946,254, filed Nov. 15, 2010 (now U.S. Pat. No. 7,991,517), which, in turn, was a continuation of U.S. patent application Ser. No. 11/899,827, filed Sep. 6, 2007 (now U.S. Pat. No. 7,835,824).

[0002] This application claims priority from provisional application No. 60/842,600 filed Sep. 6, 2006; U.S. patent application Ser. No. 11/899,827, filed Sep. 6, 2007 (now U.S. Pat. No. 7,835,824), issued Nov. 16, 2010; U.S. patent application Ser. No. 12/157,469, filed Jun. 11, 2008 (now U.S. Pat. No. 8,233,672); and U.S. patent application Ser. No. 12/946,254, filed Nov. 15, 2010 (now U.S. Pat. No. 7,991,517). This application also incorporates by reference U.S. Pat. No. 6,917,863 and the subject matter of each of the U.S. patent application Ser. No. 10/919,169 (now U.S. Pat. No. 7,840,317), Ser. No. 11/373,712 (now U.S. Pat. No. 7,837,143), Ser. No. 11/385,270 (now U.S. Pat. No. 7,350,748), Ser. No. 11/388,311 (now U.S. Pat. No. 8,164,464) and Ser. No. 12/157,469 (now U.S. Pat. No. 8,233,672).

BACKGROUND OF THE INVENTION

[0003] The present invention concerns a method and apparatus for “policing” unmanned aircraft, such as “untanned aerial vehicles” (UAs) and “unmanned aerial systems” (UASs). The invention is specifically directed to the problems posed by (1) a usurpation of control of an unmanned aircraft by an unauthorized third party, (2) the operation of a malfunctioning unmanned aircraft, and/or (3) the ill-intentioned use of an unmanned aircraft thus posing a danger to person and/or property.

SUMMARY OF THE INVENTION

[0004] The systems and methods described herein are intended to prevent the use of unmanned aircraft, e.g. UAs and UASs, hereinbelow “UA”, for unauthorized and possibly ill-intentioned purposes.

[0005] The approaches to such prevention, set forth in applicant’s parent application Ser. No. 12/946,254, filed Nov. 15, 2010, and U.S. patent application Ser. No. 11/899,827, include: A) Approach #1: Failure to provide a unique identification or password on request makes the VA subject to destruction.

[0006] This approach requires:

[0007] 1) that all UA have a unique identification, “UI”, consisting of digits, numbers, both or any reproducible information carrying identifier; and

[0008] 2) that such identification is either permanently unalterable, or alterable only by an authorized person or entity; and

[0009] 3) that such identification must be able to be presented at any time that an authorized person or entity requests;

[0010] The UI may be either:

[0011] 1) supplied to the UA at the time of aircraft manufacture, or some later time substantially prior to takeoff;

[0012] 2) supplied to the UA immediately prior to takeoff. Such pre-takeoff UI supply approaches parallel the encryption key supply approaches described in U.S. Pat. No. 6,917,863, and include generation of the UI:

[0013] a) onboard the UA;

[0014] b) from a remote control center “RCC”; or

[0015] c) from a freestanding generation device; or

[0016] 3) both: In this case the UI is supplied at some early instance and a password, “PW”, is supplied immediately prior to takeoff. The password may have the same three possible sources as the UI.

[0017] A request for UI or PW presentation may be made at the time of takeoff, or at any time during a UA flight. If there is either no response or an incorrect response, corrective actions include:

[0018] 1) dispatch an interceptor aircraft, “IAC”, which may:

[0019] a) further/better identify the UA; and/or

[0020] b) determine that the UA flight should be terminated.

[0021] If flight termination is selected, IAC options include:

[0022] a) disable or shoot down the UA using a weapon system aboard the IAC; or

[0023] b) activate a self-destruct system—if included in the UA design [discussed hereinbelow]; and

2) activate a self-destruct system—if included—from the RCC.

[0024] B) Approach #2: Failure to comply with a pre-registered flight plan makes the VA subject to destruction. In this approach, the UA is required to file a flight plan prior to takeoff. If the flight plan is unacceptable, takeoff is unauthorized, and any of the means for aircraft destruction or incapacitation discussed hereinabove and hereinbelow may be enacted. Methods of monitoring compliance with the flight plan during flight include:

[0025] 1) Equipment onboard the UA, continually compares the UA position as derived from GPS data or other aircraft locating means as is known in the art, (and the UA velocity vector) with the expected one, based on the flight plan. Any significant deviation from the flight plan is thus detected by onboard equipment and transmitted to an authority at a RCC, who has the options of further observation, investigation or action as described hereinabove;

[0026] 2) The UA reports only a continuous, semi-continuous or intermittent stream of GPS data (or reports it on request). Personnel within the RCC then compare such data with either:

[0027] a) the previously filed flight plan;

[0028] b) known no-fly zones; or

[0029] c) both a) and b). If the position or track of the UA is deemed unsatisfactory, RCC authority options are as stated above.

[0030] 3) Visual or radar sightings of the VA are compared with either:

[0031] a) the previously filed flight plan;

[0032] b) known no-fly zones; or

[0033] c) both a) and b).

[0034] If the position or track of the UA is deemed unsatisfactory, RCC authority options are as stated above. The sighting information is obtained by any of the following “monitoring means”:

[0035] a) other aircraft, including:

[0036] i) passenger, commercial or military aircraft who site the UA incidentally;

[0037] ii) other UA, which are in place to police UA (and other) air traffic;

[0038] iii) an IAC, if dispatched; and

[0039] b) terrestrial stations, including RCCs and air traffic control installations; Furthermore, the VA may carry a locator beacon which assists tracking of it and serves a purpose similar to that of visual/radar sightings.

[0040] In a preferred embodiment of the invention, Approach #2 is carried out with a UA with a UI (with or without a PW). (If the UA transmits its location and/or transmits deviations from flight plan, the transmission is meaningless without a UI.) Obviously, remotely controlled destruction requires a UI.

[0041] In an alternate embodiment of the invention, an aircraft which does not have a UI, which is detected by any of the aforementioned monitoring means may be requested to present a flight plan. Such request may be transmitted to it by

[0042] 1) an IAC in close proximity, on a recognized/commonly agreed upon frequency allocation; or

[0043] 2) a non-local RCC, on such a frequency allocation, in which case coordinates with sufficient precision to identify the UA in question would be used as the identifier.

[0044] Failure to comply with the request for flight an would result in either:

[0045] 1) destruction of the UA; or

[0046] 2) escort of the VA by the IAC until such time as:

[0047] a) the UA is no longer deemed to be a threat; or

[0048] b) a decision is made to destroy the UA. C) Approach #3: Each UA is required to allow itself to be controlled by an alternate pilot, upon the request of the alternate pilot. The alternate pilot, representing a known/safe/recognized/responsible authority can:

[0049] 1) test whether the UA has such capability; and

[0050] 2) if necessary, assume control of the VA.

[0051] This approach allows policing of UAs by adding the option of alternate pilot, “Alt-P”, control. The alternate pilot controls the UA by any means of information exchange as is known in the art including radiofrequency, optical, and infrared means.

[0052] The Alt-P first determines whether the aircraft is controllable by the Alt-P. This may be determined in one or more of the following ways:

[0053] 1) The Alt-P may interrogate the UA and determine from its UI whether the UA is controllable. To do this, the Alt-P may access a database containing the UIs of known controllable UAs.

[0054] 2) The Alt-P may send a test signal on a frequency and with modulation and coding format known to be used for UAs. if the UA is a controllable one, the UA sends back a confirmation signal indicating that it is controllable.

[0055] 3) The Alt-P may send a test control signal on a frequency and with modulation and coding format

known to be used for UAs. The test control signal includes a flight control command which results in a test motion (e.g. momentarily roll five degrees one way and then momentarily roll five degrees the other way and then return to previous course). The Alt-P confirms that the desired result has occurred by either:

[0056] a) visual inspection, if the Alt-P is in the near vicinity of the UA; or

[0057] b) a telemetry signal from the UA, originating from sensors within the UA.

[0058] Test control signals may control pitch, yaw, throttles, etc.

[0059] If the Alt-P deems necessary, the Alt-P may take control of the UA and fly it to an appropriate destination.

[0060] If the Alt-P determines that the UA has been modified (e.g. post production, or even post take-off) so that the Alt-P cannot fly the UA in a way that was allowed for in the initial specifications, the Alt-P may take action to cause the destruction of the UA. (If not in visual range of the UW the Alt-P can make such a determination with a UA that has a UI.) If the UA was not designed to be controllable by an Alt-P, the Alt-P will then decide (based on existing regulations concerning controllability of a UA, and based on the actions of the particular UA) whether to allow the current UA flight to continue.

[0061] The Alt-P may be located within the vicinity of the UA, or at a greater distance. In parallel to the discussions of remote aircraft control in U.S. Pat. No. 6,917,863 and in U.S. patent application Ser. Nos. 10/919,169 and 11/373,712, the advantage of limiting Alt-P actions to local Alt-Ps is the security means available to a short range communications link (i.e. using methods such as a high output controller transmitter and a low sensitivity UA receiver, and using highly directional transmission/reception means). A short range communications link is therefore much less likely to be accessed by an unauthorized person than is a long range link. The advantage of using a long range link is that it can be accessed immediately, upon the detection of a suspicious UA; the delays implicit in

[0062] 1) sending an IAC; and

[0063] 2) awaiting its arrival at the vicinity of the UA are not encountered.

[0064] UAs which allow Alt-P systems give the UA policing community another option beyond either:

[0065] 1) further observe the UA; or

[0066] 2) destroy the UA.

[0067] Alt-P systems may be used with or without systems and with or without systems which compare aircraft position and velocity vectors with those called for by the flight plan.

[0068] The aforementioned system functions are enabled/facilitated and rendered more secure/robust by sub-systems including:

[0069] tamper detecting seals;

[0070] write-once-only-memory (e.g. so called PROMs (programmable read-only memories), EPROMs, EEPROMs, etc. as are known in the art, and as are, hereinbelow referred to as “XPROMs”);

[0071] encryption/encoding circuits and techniques;

[0072] destructive means aboard the UA. These are further discussed hereinbelow.

[0073] As a further extension and elaboration of the features of the present invention, in addition to those described above and set forth in the patent application Ser. Nos.

12/946,254 and 11/899,827, the following novel apparatus and methods are proposed and described hereinbelow.

[0074] In order to prevent the use of an unmanned vehicle (“UV”) for inappropriate or unsafe action, and to police an environment with a multiplicity of such vehicles, a dual control UV is described wherein both

- (a) the UV pilot operating pilot apparatus, and
- (b) the police operating police apparatus, may each control the UV.

B) In one embodiment of the invention, both the UV pilot and the police may transmit signals to the UV which control the UV. In a first operating state, the UV is responsive to pilot signals received from pilot apparatus for control of the motion of the UV. In a second operating state, the UV is responsive to police signals received from police apparatus for control of the motion of the UV. In a third operating state, the UV is responsive to pilot signals which are

- (a) initially transmitted from the pilot apparatus to the police apparatus, and
- (b) then relayed by the police apparatus to the UV if they contain instructions which are acceptable to the police.

[0075] In this embodiment, the police transmit another type of control signal to the UV which determines which operating state is selected.

A) Referring to the aforementioned embodiment, information from vehicle sensors necessary to for the UV pilot to control the UV

- (a) may be transmitted directly from the UV to the pilot apparatus, or
- (b) may be transmitted instead to the police apparatus, wherein the police have the option of either passing the information on to the UV pilot, or not doing so.

[0076] This allows the police another technique for interrupting pilot control of a UV.

A) In another embodiment to the invention, the primary operating state of the system comprising the UV, the pilot apparatus and the police apparatus is one in which all information (aircraft control signals and aircraft sensor information) between the pilot apparatus and the UV must pass through the police apparatus.

B) Determining the appropriateness of the action of an unmanned vehicle is related to determining the identity of the pilot of the vehicle. The actions of a vehicle controlled by a pilot known to have appropriate credentials will generally be framed or viewed differently from that of a vehicle piloted by someone with either unknown identity or credentials, or piloted by someone with an identity indicating a risk of inappropriate vehicular activity. Clearly, such identity determination is not nearly as straightforward as it is with a manned vehicle. Another embodiment of the invention utilizes means and methods to determine the identity of the UV pilot.

C) In particular, another preferred embodiment of the invention determines the identity of the pilot by linking each of:

- (1) one or more biologic identifiers of a person inputting UV pilot control commands to the motion of the UV; and
- (2) the aforementioned biologic identifiers to known biologic identifiers in a database (which in turn links these identifiers to alphanumeric and other information).

[0077] The composite of these two links thereby associates a name with the pilot of the UV, with a high degree of certainty.

A) Additional means and methods are discussed for providing strong evidence for aforementioned linkage (1). These include:

[0078] within a single image, showing (a) pilot body parts which carry a biologic identifier and (b) the inputting of UV commands by the pilot;

[0079] demonstrating that the inputted UV commands correspond to observed UV actions;

[0080] demonstrating that the inputted UV commands correspond to observed UV control signals; and

[0081] demonstrating that a UV control action requested to the UV pilot is carried out by the UV pilot.

B) The information which demonstrates pilot identifying features and actions may be transmitted to the police apparatus:

- (a) from the UV;
- (b) directly from the pilot apparatus; and
- (c) from the pilot apparatus via the UV.

[0082] Similarly, the request for such information may be transmitted from the police apparatus:

- (a) to the UV;
- [0083]** (b) directly to the pilot apparatus; and
- (c) to the pilot apparatus via the UV.

BRIEF DESCRIPTION OF THE DRAWINGS

[0084] FIG. 1, comprising FIGS. 1A and 1B in combination shows a flow diagram of the operation of an algorithm for the policing of UAs.

[0085] FIG. 2 shows a block diagram for determining the source of control of a UA.

[0086] FIG. 3 shows another block diagram for determining the source of control of a UA.

[0087] FIG. 4 shows a system of highly directional transmission between a UA and an aircraft for policing UAs.

[0088] FIG. 5 shows another system of highly directional transmission between a UA and an aircraft for policing UAs, which includes a terrestrial station.

[0089] FIG. 6 shows a block diagram of apparatus for policing UAs.

[0090] FIG. 7 shows a block diagram of apparatus aboard a UA which allows it to be policed.

[0091] FIG. 8 shows a block diagram of apparatus aboard a UA which allows the assessment of its response to a policing authority command.

[0092] FIG. 9 shows a block diagram of apparatus aboard a UA which allows its destruction, if appropriately commanded.

[0093] FIG. 10 shows apparatus to be used by a policing authority, for identifying UAs which may need assessment, because of potential, possible or actual inappropriate behavior by the UA.

[0094] FIG. 11 shows a block diagram of an unmanned vehicle system with two sources of control and with three operating states.

[0095] FIG. 12 shows a block diagram of an unmanned vehicle system with a police unit interposed between the pilot and the vehicle.

[0096] FIG. 13 shows a block diagram of the relationship among biologic identification information, signals which traverse a system for remotely controlling a vehicle, and events involved in the remote control process.

[0097] FIG. 14 shows a block diagram of another unmanned vehicle system in which a police unit may obtain information from either the vehicle or the pilot.

[0098] FIG. 15, comprising FIGS. 15A to 15E shows five different approaches to police gathering of information, in an unmanned vehicle system.

DESCRIPTION OF THE PREFERRED EMBODIMENTS

[0099] FIG. 1 consists of FIG. 1A and FIG. 1B, and shows an algorithm for policing UAs. The algorithm begins with block 10, an indication of a possibly improper UA. The basis of the impropriety could be: a) information provided to a policing authority (PA) from one of many possible sources of security information; b) information from a computer (or person who operates the computer), which tracks the position of UAs; c) information from a computer (or person who operates the computer), which tracks the flight plans of UAs; d) information from a computer (or person who operates the computer), which compares the positions and flight plans of UAs, and e) GPS or radar or other sighting information (from a ground-based, sea-based, air-based or space-based observer or observation apparatus, indicating encroachment of a UA into a sensitive space. "Possible T.O. Trigger" 10 indicates an indication, such as listed hereinabove, for possible takeover (TO) of the UA. The takeover would result in a) removal of the UA pilot (first pilot herein) control; and b) institution of control by either a local or remote pilot (second pilot) who is part of a PA. In one embodiment of the invention, the first pilot PA checks the identification of the UA, block 12. The check could entail any one of a variety of methods known in the art, including: a) interrogating an identifying device aboard the UA; and b) observing the exterior of the UA, which may include:

[0100] i) identifying alphanumeric or other surface based pattern, using visible light,

[0101] ii) using a laser to identify coded paint, as is known in the art.

[0102] The interrogation of the identifying device, above, may take place by radiofrequency communication on a channel which has been designated specifically for the purpose of UA identification (ID) and policing. If one or more such channels are allocated, the PA may need to attempt communication on each such channel. The ideal situation would be statutory requirement that every UA (or almost every UA) be outfitted with equipment which allows communication on a known, agreed upon channel, using an agreed upon communication protocol known to at least the PA and the UA operator.

[0103] At block 14, the PA determines if the ID is acceptable. Such determination may be based on: a) a list, appropriately disseminated, of properly registered UAs; and/or b) a list, appropriately disseminated, of UAs which are on a "watch list," indicating the potential for inappropriate UA behavior.

[0104] If the ID is acceptable, block 16, the PA:

[0105] a) may end the communication encounter, in which case the PA options, block 18, would be:

[0106] i) ending the observation of this particular UA; or

[0107] ii) continuing observation (with some enhancement of the level of surveillance above that of other UAs), with or without escorting the vehicle. If the PA is aboard an aircraft in proximity to the UA,

such escorting may begin promptly. If the PA is not in proximity to the UA, escorting may consist of dispatching a chase aircraft which flies to the location of the UA and stays in proximity until there is no longer any need for escort.

[0108] If the identification is unsatisfactory, or if—at block 16—the PA chooses not to end the communications encounter with the UA, the PA, block 20, may request one or more of:

[0109] a) a UA flight plan; b) the UA GPS history (i.e. a history of each previous location that the UA has been, indicated by space and time coordinates); and c) a comparison of the UA flight plan and the GPS history, the comparison indicating whether the UA has complied with its flight plan. Each of a) b), and c) may be stored in a memory unit within the UA, or stored in a ground based facility that tracks UAs, see hereinbelow.

[0110] If the PA finds that the flight plan, the GPS history, and/or the comparison of the two is acceptable, then block 22 leads to 24, at which point the PA may choose to end the communications encounter, with options then per block 18, as discussed hereinabove.

[0111] If (a) the flight plan/GPS history analysis yields unsatisfactory results, or is not responded to at block 22: or if (b) at block 24 the PA decides that not enough information has been presented to reach a decision about whether the UA flight should be allowed to continue under the control of the first pilot, then, at block 26, the PA requests communications information from the UA. This information may include one or more of:

a) the frequency or channel on which the UA transmits telemetry to the UA pilot; b) the frequency or channel on which the UA receives commands from the UA pilot; c) the system or methodology that the UA and the UA pilot use for channel hopping; d) the system or methodology that the UA and the UA pilot use for encoding and decoding exchanged information; e) the system or methodology that the UA and the UA pilot use for encrypting and decrypting exchanged information; f) passwords, if any; and g) any other communication formatting or executing information necessary for the PA pilot to fly the UA.

[0112] The step of requesting the communications information may come earlier in the algorithm shown in FIG. 1. It may come between blocks 10 and 12, or it may come immediately before block 20. Furthermore, the request for information may be from another UA or the pilot of another UA.

[0113] If the requested information is not supplied, block 28 to block 32, the PA options include:

a) escorting the UA (with the option of more aggressive action at a later time); b) destroying the UA; c) requesting instructions from a higher authority; and d) attempting communication with the UA; If this leads to establishment of a working communications link, the algorithm proceeds as described hereinbelow for block 34; If this does not lead to a working link, options a), b) and c) remain as choices. The attempt d) may entail a trial-and-error effort to determine the needed communication parameters, or may entail use of information stored in a database.

[0114] The PA may skip to the options listed in block 32 if an unsatisfactory result occurs at the time of either ID checking or the assessment of flight plan and/or GPS history.

[0115] If the requested communication information is supplied, block 28 to 30A to 30B (FIG. 1A, and continuing on

FIG. 1B) to 34, the PA sends a takeover command to the UA. In one preferred embodiment of the invention, the takeover (TO) command causes

a) the UA to allow piloting by the PA; b) the UA to exclude piloting by the UA pilot (the first pilot); and c) the UA to send a confirmation signal that the TO command has been executed. Apparatus which allows for the execution of such a commands is presented hereinbelow.

[0116] In other embodiments of the invention:

a) there may not be a TO confirmation signal; b) there may not be a lockout of the first pilot from control; and c) there may not be a unique TO command; Rather, specific commands (e.g. move rudder by a specific amount) would be sent to the UA.

[0117] Referring again to the embodiment in which a confirmation signal is sent when a TO command is enacted, if the TO confirmation is not received following the transmission of a TO command, block 34 to 36 to 38A to 38B (FIG. 1A) to 32 with options including: include:

a) escorting the UA (with the option of more aggressive action at a later time); b) destroying the UA; c) requesting instructions from a higher authority; and d) again transmitting a TO command.

[0118] If a TO confirmation signal is received, block 34 leads to 36 and then to 40, at which time the PA may attempt to execute a test maneuver. The test maneuver is the transmission of a command which causes a change in aircraft attitude which may either be directly observed by a local PA (e.g. bank five degrees), or may be detected by apparatus onboard the UA (see below).

[0119] The purpose of the maneuver is to attempt to distinguish ill-intentioned UA pilots/vehicles from those with benign intentions; The assumption is that an ill-intentioned UA pilot would be much less likely to comply with a request to allow takeover of the UA by the PA. (Though it may be the case that an ill-intentioned UA pilot would not allow for the transmission of information requested in blocks 12, 20 and 26, such denials are dealt with by the algorithm [and lead to block 32].) It may be that an ill-intentioned pilot would have allowed the transmission of information at blocks 12, 20 and 26 hoping to avoid detection.

[0120] If the test maneuver is not executed successfully, block 40 leads to 42, then to 38C and then to 38B (in FIG. 1A), with PA options including:

a) escorting the UA (with the option of more aggressive action at a later time); b) destroying the UA; c) requesting instructions from a higher authority; and d) again transmitting a test maneuver.

[0121] If the test maneuver is successful (indicating that the PA is indeed capable, at this point, of piloting the UA) then block 40 leads to 42, and then to 44 with PA options including:

a) the PA, now in control of the UA, flying the vehicle to a more secure location; b) escorting the UA (with the option of more aggressive action at a later time); c) returning control of the vehicle to the first (i.e. UA) pilot; d) requesting instructions from a higher authority. The reasoning behind option c) is that if the first pilot permitted each of the aforementioned steps/requests by the PA, the likelihood of his being an ill-intentioned pilot is substantially decreased, compared to the pre-evaluation likelihood.

[0122] FIG. 2. shows a form of apparatus which may be aboard a UA which allows for the aforementioned tasks

including the transfer of control from the first pilot to the PA following a TO signal, and the transmission of a TO confirmation. The switching apparatus shown is intended to be viewed schematically; though an “old technology” double-pole-double-throw relay may accomplish the task of switching control from the VA pilot (also referred to herein as “pilot 1”) to the PA (also referred to as “pilot 2”), more sophisticated switching arrangements, including computer hardware and/or software based approaches, are possible and are known in the art.

[0123] In the figure, signals to the UA are received by 50, and decoded (and decrypted, as necessary) by 52. Under ordinary circumstances, the UA first pilot control signals 54C pass to the appropriate item to be controlled 58 (e.g. rudder, throttles etc.) via the path 54C to 56E to 56C to 56B to 56A to 58. (The poles in the figure are shown in the other position, i.e. allowing control by the PA pilot.)

[0124] When the PA wishes to take control of the aircraft, a switch control signal is sent along the path 50 to 52 to 54A to 56L. Switch control 56L causes the two components of the switch to move to the pilot 2/PA pilot (i.e. the left-most position in the figure). The result is that pilot 1 control signals can no longer pass beyond 56E, and that pilot 2 signals control items 58 along the path 50 to 52 to 54B to 56D to 56C to 56B to 56A to 58. If, at a later time, the PA is satisfied that control of the UA can safely be returned to the first pilot (option 3 in block 44 of FIG. 1B), a switch control signal sent to 54A restores control to the first pilot.

[0125] The switch components 56F, 56G, 56H, 56J and 56K allow the PA to know the switch position: Switch position indicator 60 senses which of two positions the switch is in, via 56F-56K, the information is encoded and preferably encrypted at 62 and transmitted to the PA by 64.

[0126] An alternate embodiment of the switching arrangement is shown in FIG. 3. FIG. 3 differs from FIG. 2 only in that FIG. 3 contain separate receiver/decoder elements for the pilot 41 signals and for the pilot #2 signals. One way of limiting the chance that an unauthorized person/hacker could usurp the authority of the PA and attempt to obtain control over a UA would be to use one or more of:

a) high output transmitters for PA control signals; b) low sensitivity receivers for PA control signals; c) highly directional antennae at each end of the PA-VA communication link; d) upwardly oriented UA antennae, to communicate with a PA aircraft located at a higher altitude than the UA (This might require an antenna for UAV-PA communication which is separate than the one for LA-first pilot communications. [The separate antenna is not shown in the figure]; and e) time dependent varying of the orientation of either the PA antenna or the UA antenna (with corresponding adjustments by the PA pilot to compensate for such orientation changes). In addition, the aforementioned unauthorized controller exclusion would employ encoding and encryption techniques as are known in the art.

[0127] Referring again to FIG. 3, first pilot signals are received along the path 70 to 72. to 74, PA pilot signals are received by a low sensitivity receiver 76, decoded by 78, thereby giving rise to pilot #2 (PA pilot) control signals 80 and pilot #2 switch control signals 82. Embodiments of the invention with two receivers (70 and 76) and a single decoder are possible. Embodiments of the invention which share not only a decoder but which also share all but the “front end” of the receiver are possible.

[0128] FIG. 4 shows the use of highly directional apparatus aboard the UA 100 and a PA aircraft 114A. Control signals 122 are sent from an airborne remote control center 116 via directional antenna 118A aboard 114A to directional antenna 120. Directional apparatus may also be for transmission from 100 to 114A.

[0129] FIG. 5 shows an embodiment of the invention in which an intercepting aircraft 114B acts as a repeater unit, allow a terrestrial (land or sea-based) remote control network 103 to control a UA 100. Signals to the UA traverse the path 103 to 113 to 118B to 128 (signal repeater equipment) to 118A giving rise to signals 122 to 120 to 100. (The reversed sequence pertains to telemetry and other signals from 100 to 103.) Antennae 113 and 118B would be operative to vary their orientation to optimize signal strength based on the positions of 103 and 114B.

[0130] FIG. 6 shows apparatus which comprises a preferred embodiment of the PA apparatus for communicating with a UA. The PA inputs commands via input device 140, which are transmitted by 144. The PA receives UA signals via 134 which may be linked directly to display device 138, or to 138 via logic device 136. 136 allows for the comparison, if desired by the PA, of GPS history and intended flight plans. The flight plans may be stored in memory 142 or received at the time that the GPS history is received. 142 may also store a list of potentially problematic UAVs, i.e. UAVs to be watched more carefully than others. 142 may also store flight routines which allow a PA pilot to fly a UA to a specific destination with a minimum of control activity; 140 may input the control signals which allow for these flight routines to go directly to 144, or to go to 144 from 142. 142 may also serve to record all PA actions that issue from 140. The combination of 136 and 142 may act as a flight management computer and/or autopilot for the UA when it is controlled by the PA who provides input via 140.

[0131] FIG. 7 shows a system aboard the UA which communicates with that of the system shown in FIG. 6. The system in FIG. 7 contains receiver 150, which,

[0132] 1) on receipt of a suitable signal, 150 causes identification XPROM 152 (which is either a PROM, an EPROM, an EEPROM or similar write-once-only-memory device as is known in the art) to signal transmitter 154 (and/or causes transmitter 154 to send the UI contained in 152);

[0133] 2) on receipt of another type of signal, and of flight plan information, causes the writing of flight plan information into flight plan XPROM 156;

[0134] 3) on receipt of another type of signal, causes the transmission of flight plan information from 156 to 154 to the PA;

[0135] 4) on receipt of another type of signal, causes the transmission of communications information from XPROM 153 to 154 to the PA;

[0136] 5) on receipt of another type of signal, causes the transmission of real-time GPS information from 158 to 154 and then to the UA;

[0137] 6) on receipt of another type of signal, causes the transmission of either:

[0138] i) GPS history stored in 160, to 154, to the PA;

[0139] ii) a comparison of the GPS history stored in 160 and the flight plan information, to 154, to the PA. 160 may be a computer, part of a computer, a microprocessor, part of a microprocessor or a logic device or system of logic devices as is known in the

art. GPS or other locator system information may be: a) transmitted to a remote control center (RCC); b) used as a basis for assessing compliance with the flight plan. The GPS data may be used to generate both the expected UA position and the expected UA velocity,

[0140] 160 may cause the transmission of:

a) all "raw data" related to the comparison of GPS data and the flight plan; b) only the results of such comparisons that indicate significant deviation from the flight plan.

[0141] In a preferred embodiment of the invention, the apparatus consisting of elements 150 through 160 is enclosed within tamper detecting seal (TDS) 162.

[0142] FIG. 8 shows apparatus aboard the UA which allows the RCC to determine if a test command sent by it has been received and executed. Not shown in the figure is:

a) the receiver which receives the command; b) the aircraft apparatus which carries out the command; and c) the linkage between a) and b).

[0143] If and when the command is executed, one of roll detector 200, pitch detector 202 or yaw detector 204 will register a change in sensed input corresponding to which of these was associated with the test command. (Other test commands are possible.) The output of these detectors is transmitted at 206. In a preferred embodiment of the invention, the transmission is accompanied by a UI from XPROM 208. In a preferred embodiment of the invention, the apparatus comprising elements 200-208 is enclosed in TDS 210.

[0144] FIG. 9 shows an apparatus which allows remotely triggered destruction of a UA. The apparatus is enclosed in TDS 220. Transmitter 222 confirms the identity of the UA with a UI from 224. In the event that an authorized person determines that it is not appropriate for the UA to continue its flight, and in the event that such authorized person does not wish to or cannot take control of the UA as a second pilot and fly it to an appropriate destination, the authorized person would have the option of destroying or incapacitating the UA using apparatus aboard the UA shown in the figure.

[0145] If the authorized person makes a destruct decision, a destruct signal, "DS" is sent. The DS is received by 225, from which, after appropriate decoding and decryption, a destruct signal is generated, indicated by element 226. Four options for executing such destruction are illustrated in the figure:

a) 228, indicating apparatus for interrupting electrical power distribution to critical elements within the UA; b) 230, indicating apparatus for the interruption of fuel flow within the UA; c) 232, indicating apparatus for interrupting the linkage to moving aircraft control elements (throttle, rudder, ailerons, flaps, etc.); and d) 234, indicating one or more explosive charges carried by the UA, which may be detonated in response to a signal 226.

[0146] FIG. 10 shows apparatus with which a remote control center (either terrestrial or airborne) may determine whether UA location and/or UA flight plans are appropriate. Receiver or datalink 240 receives four types of information:

a) filed flight plans 242; b) GPS information 244, transmitted from GPS apparatus aboard UAs; c) UA sighting information 246 (e.g. other aircraft reporting on the presence of a particular UA at a particular time and location); and d) deviation signals 248 (such as those generated by element 160 in FIG. 7).

[0147] Comparison computer microprocessor/logic system 250 compares:

a) actual UA position information from 244 and 246 with expected UA position information from 242; b) actual UA position information with known “no-fly” zones (stored in database 252); and c) filed flight plans with no-fly locations.

[0148] 254, i.e. (A) 248, and (B) the output of 250, indicating any of the three types of aforementioned deviations are displayed by 256. In a preferred embodiment of the invention, the display may also indicate one or more of:

a) the UI of the deviated UA; b) the magnitude of the deviation; c) historical information about the flight: i.e. details about the portions of the flight, if any, prior to the deviation; d) historical information about the particular UA including:

[0149] 1) prior flights; and

[0150] 2) the owner; and

[0151] e) enroute weather information for the UA, as a possible explanation for an off-course location.

[0152] The airspace may be patrolled for inappropriate UA activity by:

a) existing patrol networks; b) one or many unmanned aircraft for the specific purpose of policing UAs; c) one or many manned aircraft whose primary purpose is either passenger/commercial or military, but which may be outfitted with UA policing equipment; and d) combinations of a), b) and c).

[0153] Each of FIGS. 11-15E refers to an unmanned vehicle (“UV”) system which is policed for inappropriate action by the pilot or the vehicle. Such UV’s may be air vehicles, (UAs), ground vehicles, underwater vehicles or space vehicles. For convenience, in each case, the person who is the primary controller of the vehicle is referred to as the “pilot,” while the person or device which monitors and, if necessary, takes control away from the pilot is referred to as the “police,” or “police person.”

[0154] The police may be any monitoring agency. The term police is intended in a generic sense, and may include law enforcement, private monitoring and enforcement organizations, and teaching entities (who teach new pilots to operate UVs).

[0155] Although the specific type of telemetry signals sent to the pilot(s), and control signals sent to the UV will depend on the particular type of vehicle, the system concepts and apparatus interactions are largely independent of whether the vehicle is an air vehicle, a ground vehicle, a space vehicle, an underwater vehicle, or a vehicle capable of navigating more than one of such media.

[0156] FIG. 11 shows an unmanned vehicle system in which UV 300 is controlled by pilot apparatus 302. The pilot receives vehicle data signals via the route vehicle sensor 306 to vehicle processor 308 to vehicle transmitting device 310, to pilot receiving device 312 to pilot processor 314, after which the sensor information is available for display by device 316. In the case of an aircraft such data includes but is not limited to GPS information, airspeed, horizontal velocity, vertical velocity, roll, pitch, yaw information, derivatives of each of the aforesaid. The pilot inputs commands to control the vehicle to input device 318. The inputted commands are passed to the vehicle along the route 318 to processor 314 to transmitting device 320 to vehicle receiving device 322 to processor 308. The processor provides actuator control signals 324 for actuators 326, which control various vehicle control devices as are known in the

art. Such control devices include but are not limited to devices which control the orientation of a vehicle 328 (e.g. steering apparatus in a ground vehicle, a rudder in an air or underwater vehicle, steering jets in a space vehicle, etc.); and devices which control the velocity and acceleration of a vehicle 330 (e.g. throttles in a hydrocarbon burning propulsion system, voltage of an electric engine whose speed is voltage dependent, etc.).

[0157] Vehicle 300 is monitored by police apparatus 304 for inappropriate actions which may be caused (a) intentionally by the pilot, (b) unintentionally by the pilot, (c) by vehicle malfunction, or (d) due to problematic interaction with another vehicle. This police monitoring is accomplished in a manner which is analogous to that by which information reaches the pilot: Telemetry signals from vehicle sensors 306 provide information along the path 306 to vehicle processor 308, to vehicle transmitting device 310 to police receiving device 332 to police processor 334 to police display device 336. In one embodiment of the invention, a police person observes the display (and may observe one or more other vehicle information displays), and, if necessary inputs commands via input device 338 to (a) take control of the vehicle away from the pilot, and (b) control the vehicle from apparatus 304. In another embodiment of the invention, processor 334 may perform such function without human intervention. In yet another embodiment, both human and processor analysis and/or decision making occurs. The commands to control the motion of the vehicle are transmitted as signals 340 by police transmitting device 342 to vehicle receiving device 332, and thence traverse the same path as did signals 344 from device 302.

[0158] The vehicle processor is operative to receive another control signal 346 from the police unit which determines the source of control of the UV. The control input which determines the UV source of control is inputted at 338 (which may be a single input device or, in a preferred embodiment of the invention, is a plurality of input devices).

[0159] There are three control scenarios, and the choice of control scenario is determined by signal 346:

[0160] (1) vehicle instructions 344 from pilot unit 302 directly control the UV,

[0161] (2) vehicle instructions 340 from police unit 304 control the UV, and

[0162] (3) vehicle instructions 348 from pilot unit 302 are passed to police unit 304, and, if continuing access to UV control by 302 is allowed, these instructions are passed on to the UV. The route for such signals in this third scenario is 318 to 314 to 320 to 332 (as signals 348) to 334 to 342 to 322 (as signals 340).

[0163] Scenario (3) is a probationary one for the pilot/UV. In the event that there is a high level of concern that a police intervention will be necessary, and/or when an additional degree of isolation of the pilot from the UV is desirable, then control scenario (3) may be selected. For example, in the case of intermittent malfunction of processor 308, by allowing the pilot control interruption to take place at the police unit, scenario (3) offers additional opportunity for interrupting pilot control.

[0164] Other approaches to manipulating pilot access include the control of pilot access to vehicle telemetry signals. The figure shows a direct link between 310 and 312, but embodiments of the invention are possible in which control of access to these signals is accomplished by routing

them through the police unit. Scenarios in which processor 308 is operative to lockout telemetry signal transmission to unit 302 are possible.

[0165] In the event that additional verification of who is piloting the vehicle is required, the pilot may input biologic information to 350 such as a fingerprint; an image of a face, a palm, a voiceprint, an iris, and a retina; a DNA sample; and other biologic identification inputs as are known in the art. The biologic information is passed to the police unit for comparison with a database 352 of biologic identifying information of certified pilots. The comparison of the stored and received biologic information may be performed by processor 334 or by a person observing 336.

[0166] If the UV or pilot action is deemed to be inappropriate, threatening or dangerous, the police have a variety of options for supplementing control scenarios (2) and (3) [presented hereinabove] including notification of various authorities. They may also be equipped with a weapon device (e.g. element 550 of 14 and elements 225, 226 and 234 of FIG. 9) which can disable or destroy the UV. The inclusion of such apparatus is applicable to each of the embodiments of the invention discussed hereinbelow.

[0167] FIG. 12 shows an embodiment of the invention in which police apparatus 400 is interposed between UV 402 and pilot apparatus 404. Vehicle telemetry signals 406 destined to the pilot apparatus must pass sequentially through the receiver, processor and transmitter of the police apparatus 400, emerging as signal 408, and may be interrupted by the police apparatus if necessary. Inputted pilot signals 410 which are intended to control the UV are transmitted as 412, traverse the police apparatus, and may thus be interrupted if interruption is deemed necessary; if interruption is not deemed necessary, the control signals are transmitted as 414 to the UV.

[0168] Biologic identification 416, as discussed hereinabove and hereinbelow may be inputted to device 418, transmitted to the police, and compared with certified and/or registered pilots whose information is stored in 420.

[0169] In the event that at some point the pilot and the UV are deemed to be sufficiently reliable that police monitoring is no longer appropriate, in one embodiment of the invention, the police may alter the control scenario so that the pilot may directly communicate with the UV. This may be accomplished by:

[0170] a) sending a signal 422A which alters UV receiver 424 characteristics so that the receiver is operative to receive signals from 404;

[0171] b) sending a signal 422B which alters UV processor 426 characteristics so that the processor is operative to process signals from 404;

[0172] c) sending a signal 428A which causes pilot processor 432 to alter pilot transmitter 430 characteristics so that the receiver 424 is operative to receive signals from 430;

[0173] d) sending a signal 428B which alters pilot processor 432 characteristics so that the processor is operative to process outgoing signals from 404 so that they may be received and processed by the UV;

[0174] e) informing the pilot of various security measures, passwords, identification numbers, secure channel information, etc. that would allow the pilot to directly communicate with the UV; and

[0175] f) combinations of a)-e).

[0176] Having given the pilot direct access, the police may rescind this access at a future time. Signals analogous to, but opposite in effect to the aforementioned a)-d) may accomplish this task, as would altering passwords, ID numbers, etc.

[0177] Other techniques for heightening police-to-UV communication security, as are known in the art, facilitate the accomplishment of the aforementioned tasks including highly directional antennae, frequency hopping, low sensitivity receivers and high output transmitters, and schemes for encrypting and encoding as are known in the art. Each of these techniques is applicable to each of the inventions discussed hereinabove and hereinbelow.

[0178] The ability to identify exactly who the UV pilot is, is important for safe operation of UVs. As the number of UVs, UV pilots, and UV-using organizations increases over time, this will become increasingly important.

[0179] As is shown diagrammatically in FIG. 13, the simplest approaches to pilot identification involve the pilot inputting alphanumeric information 450, e.g. a name, an identification number, a password, etc. But none of these assure that the person inputting the information is the person they claim to be. A higher level of security involves the aforementioned examples of requiring the input of a biologic identifier 452 as well as an alphanumeric one. This allows for a more secure identification, i.e. it allows for the demonstration that the person who is at the controls of a pilot control station is properly identified. But even this approach is defeatable, since such biologically identified person may not be the one actually controlling the UV.

[0180] Additional methods, as indicated in FIG. 13, which allow for even greater certainty that the biologically identified person is controlling the UV entail one or more of:

[0181] a) as indicated by 454: imaging a body part (e.g. the hand) of the pilot as the hand inputs vehicle control commands 456, 462 and 464; this technique is rendered more secure if images which show the body part which inputs the commands also include contiguous body parts which include an identifiable feature (e.g. face, iris, etc.) of the pilot. This matter is the subject of U.S. Pat. No. 8,233,672;

[0182] b) determining the result of the input which was verified as above by observing one or more of (i) the performance 458 of the UV immediately following the inputting of the command, and/or (ii) the outputted signal 466 (e.g. 324 of FIG. 11) at the UV, if accessible. The performance of the UV may be observed directly 458 by a nearby observer, observed indirectly by techniques such as radar, or observed 460 by receiving telemetry signals from the UV sensors that supply the UV pilot with information for flying the vehicle;

[0183] c) providing the UV pilot with a command 462 to be inputted to the UV, and thereafter observing (by any of the techniques in b)) the results. The resulting UV motion, for example, could thus be compared with the police-requested UV motion. The demonstration that the requested motion 462 is similar to or substantially the same as the observed motion following the request 458, 460, along with evidence that a biologically identified person inputted a vehicle command to carry out the motion in the same time frame (452, 454), serves as strong evidence that the pilot of the vehicle is known (and is cooperating).

[0184] The relationship between these identifiers, the techniques for applying them and the flow of information and signals underlying the aforementioned identifications is shown in FIG. 13.

[0185] FIG. 14 shows apparatus which utilizes the aforementioned relationships for policing UV 500. The UV is controlled by a pilot utilizing pilot apparatus 502. The police apparatus 504 may obtain information from either UV 500 or pilot apparatus 502.

[0186] For example, if the police wish to obtain biologic information showing a pilot's face, the pilot's hand inputting vehicle controls, and contiguous body parts in the same image as the hand and face, video camera information would be inputted to 506 and transmitted by 508. It could be transmitted directly to receiver 510 by signal 512, or via the UV, by signals 514 and 516. The information would be supplemented by imaging within the same image as face, hand and contiguous body parts—the input device, preferably with enough detail to allow a police person to determine the command that was inputted. The identification process may be further supplemented by also showing the pilot display device in the same image.

[0187] The incoming biologic information at 504 is compared to that stored in a database 524. The results of the comparison may be displayed as side by side images by 526. Alternatively, processor 528 may analyze the extent of a match and display information showing such analysis on 526. It may also show alternative choices for a match to the image.

[0188] If the police wish to have confirmatory information that the pilot's command was inputted to the UV under observation, then simultaneous police observation of the UV sensor output (by the signal path 518 to 520 to 522 to 510) and of a biologically identified pilot inputting this command, as per 454 of FIG. 13 (and the method of the aforementioned U.S. Pat. No. 8,233,672), would allow for this.

[0189] Another approach to confirmation would be to transmit a copy of the actuator inputs 530 for the UV. The signal path to the police unit would be 520 to 522 to 510.

[0190] Referring to FIGS. 13 and 14, any two or more of the following types of identification data may be compared:

- a) alphanumeric data pertaining to the pilot 450;
- b) biologic identification data pertaining to the pilot 452;
- c) biologic data pertaining to known registered pilots 524;
- d) video information showing the pilot inputting a command to control the UV 454;
- e) audio information containing voiced pilot commands 456, and analyzed for voiceprint data 452;
- f) UV motion 460 (i.e. following either a spontaneously inputted command 456, or a requested command: 462 and 464 of FIG. 13; and e.g. along the route 540 to 528 to 542 to 544 to 520 to 522 to pilot apparatus receiver of FIG. 14);
- g) external observation 458 of the UV following either a spontaneously inputted command 456, or a requested command 464 (as discussed hereinabove); and
- h) decoded output signals 466, 530, from the UV processor intended for a UV actuator.

[0191] FIGS. 15A-E show a variety of possible information routes for police (POL.) request of information, and for supplying the information to the police. FIG. 15A shows communication (signals 500, 570) between police apparatus and a UV, with exclusion of communication between the pilot apparatus and the UV, such as [i] scenario (2) with respect to the apparatus of FIG. 11, and [ii] during exclusion

of the pilot with respect to the apparatus of FIGS. 12 and 14. FIGS. 15B-15E show four formats for communication between pilot apparatus and police apparatus exemplified in FIGS. 11 and 14. FIG. 15B shows a communications format in which each of a signal requesting pilot identification (562A, 562B), and a signal providing such identification (572A, 572B, 572C) traverses the UV communications apparatus. FIG. 15E shows a communications format in which each of a signal requesting pilot identification (568), and a signal providing such identification (578A, 578B) is exchanged without traversing the UV communications apparatus. FIGS. 15C and 15D are hybrid versions of FIGS. 15B and 15E: FIG. 15C shows a communications format in which the signal requesting pilot identification (564A, 564B) traverses the LV communications apparatus, and in which the signal providing such identification (574A, 574B) does not traverse the UV communications apparatus. FIG. 15D shows a format in which the signal requesting pilot identification (566) does not traverse the UV communications apparatus, and in which the signal providing such identification (576A, 576B and 576C) does traverse the UV communications apparatus.

[0192] There has thus been shown and described a novel method and apparatus for managing unauthorized use of an unmanned aircraft which fulfills all the objects and advantages sought therefor. Many changes, modifications, variations and other uses and applications of the subject invention will, however, become apparent to those skilled in the art after considering this specification and the accompanying drawings which disclose the preferred embodiments thereof. All such changes, modifications, variations and other uses and applications which do not depart from the spirit and scope of the invention are deemed to be covered by the invention, which is to be limited only by the claims which follow.

1.-116. (canceled)

117. A method of confirming the identification of a pilot of an unmanned, remotely controlled vehicle ("UV"), said method comprising the steps of:

- (1) certifying that both alphanumeric and biologic identification information of a person who is a registered UV pilot, each pertain to the same person;
- (2) storing said certified identification information as the person's identification information in a computer memory of registered UV pilots ("stored II");
- (3) transmitting a request from a UV police authority to a UV for a presentation of pilot identification information ("pilot II") pertaining to a pilot ("pilot II") of said UV;
- (4) transmitting said request from said UV to a remote control station ("RCS") adapted to control said UV in response to commands inputted thereto by said pilot;
- (5) transmitting said pilot II from said RCS to said UV;
- (6) transmitting said pilot II from said UV to said UV police authority and receiving at said police authority, said pilot II ("received pilot II");
- (7) said police authority utilizing a computational device to compare said received pilot II with said stored II of registered UV pilots; and
- (8) based on the results of said step (7), indicating at said police authority whether or not said UV pilot is a registered UV pilot.

118. The method of claim 117, further including a step (9) taking a police action selected from the group consisting of

(a) destroying the UV, (b) escorting the UV, and (c) taking control of the UV, if said step (8) indicates that said pilot is not a registered UV pilot.

119. The method defined in claim **117**, wherein said biologic identification information is selected from the group consisting of:

- (a) an image of a face;
- (b) an image of a retina;
- (c) an image of an iris;
- (d) an image of at least one fingerprint;
- (e) an image of a palm print;
- (f) a voice print; and
- (g) a DNA sample.

120. The method defined in claim **117**, wherein

- (A) said step (5) further includes transmitting a plurality of images showing:
 - (i) a hand of said UV pilot actuating an input device for controlling said UV,
 - (ii) at least one body part having a visible biologic identifier selected from the group consisting of: a face, a retina, an iris, a fingerprint and a palm print of said UV pilot, and
 - (iii) contiguous UV pilot body parts situated between said hand and said body part having said visible biologic identifier;

wherein, an analysis of the combination of said images (i), (ii) and (iii) allow an identification of said UV pilot actuating said input device;

(B) said step (5) further includes transmitting data representing a control instruction inputted by said pilot for controlling a motion or an orientation of said UV from said RCS to said UV;

(C) said step (6) further includes transmitting said images and said control instruction from said UV to said police authority;

(D) said step (7) further includes utilizing said computational device to determine an inputted control instruction from said at least one image of the hand of said UV pilot actuating an input device;

and further comprising

a step (10) comparing the received control instruction with said determined control instruction of said step (7), and

a step (11) said police authority determining whether the vehicle under observation is being piloted by the pilot whose biologic identification has been inputted, in dependence upon whether said received control instruction substantially matches said determined control instruction.

121. The method defined in claim **117**, wherein

said step (3) further comprises transmitting a request from said police authority to said UV for said UV pilot to input a first police-requested instruction (“PI”) to a RCS input device;

said step (4) further comprises transmitting said first requested PI from said UV to said RCS;

said step (5) further includes transmitting data representing a control instruction for controlling a motion or an orientation of said UV, inputted by said pilot in response to said PI, from said RCS to said UV;

said step (6) further includes transmitting a control instruction representing the instruction inputted by said pilot, from said UV to said police authority;

and further comprising a step (12) comparing an instruction represented by said police authority-received control instruction with said first requested PI; and a step (13) said police authority determining if said first requested PI was inputted by said UV pilot.

122. (canceled)

123. The method defined in claim **117**, wherein

(A) said step (5) further includes transmitting a plurality of images showing:

- (i) a hand of said UV pilot actuating an input device for controlling said UV,
- (ii) at least one body part having a visible biologic identifier selected from, the group consisting of: a face, a retina, an iris, a fingerprint and a palm print of said UV pilot, and
- (iii) contiguous UV pilot body parts situated between said hand and said body part having said visible biologic identifier; wherein said images allow an identification of said UV pilot actuating said input device;

(B) said step (5) further includes transmitting control instruction inputted by said pilot for controlling a motion or an orientation of said UV from said RCS to said UV;

(C) said step (6) further includes transmitting telemetry signals from said UV, indicating an effect of said control instruction upon said UV, to said police authority;

(D) said step (7) further includes utilizing said computational device to perform a first determination of an instruction, represented by said inputted control instruction, by analyzing the effect of said inputted instruction on a motion of said UV; and said step (7) further includes utilizing said computational device to perform a second determination of an instruction, represented by said inputted control instruction, by analyzing said at least one image of the hand of said UV pilot actuating said input device;

and further comprising

a step (15) of comparing said first determination based on said effected UV motion with said second determination based on an analysis of said at least one image of the hand of said UV pilot actuating an input device for controlling said UV; and

a step (16) said police authority determining whether the vehicle under observation is being piloted by the pilot whose biologic identification has been inputted, in dependence upon whether said first determination substantially matches said second determination.

124. The method defined in claim **117**, wherein

said step (3) further comprises transmitting a request from said police authority to said UV for said pilot to input a second police-requested instruction (“PI”) to a RCS input device;

said step (4) further comprises transmitting said second requested PI from said UV to said RCS;

said step (6) further includes transmitting telemetry signals from said UV, indicating an effect of said requested instruction to said police authority;

said step (7) further includes utilizing said computational device to perform a first determination of an instruction, represented by said inputted control instruction, by analyzing the effect of said inputted instruction on a motion of said UV;

and further comprising
 a step (17) comparing said first determination based on said effected UV motion with said second requested PI; whereby said police authority determines if said second requested PI was inputted by said UV pilot.

125. (canceled)

126. The method defined in claim **117**, wherein said UV is selected from the group consisting of an unmanned aerial vehicle, an unmanned ground vehicle, and unmanned underwater vehicle, and an unmanned space vehicle.

127. The method defined in claim **123**, wherein said telemetry signals convey vehicle information including at least one of: an altitude, a latitude, a longitude, GPS coordinates, a velocity, a rate of climb, a rate of descent, a horizontal acceleration, a vertical acceleration, an attitude, a pitch, a yaw, a rate of roll, a rate of change of pitch, and a rate of change of yaw.

128. A method of confirming the identification of a pilot of an unmanned, remotely controlled vehicle (“UV”), said method comprising the steps of:

- (1) certifying that both alphanumeric and biologic identification information of a person who is a registered UV pilot, each pertain to the same person;
- (2) storing said certified identification information as the person’s identification information in a computer memory of registered UV pilots (“stored II”);
- (3) transmitting a request from a UV police authority for a presentation of pilot identification information (“pilot II”), pertaining to a pilot of a UV, to a remote control station (“RCS”) adapted to control said UV in response to commands inputted thereto by said pilot;
- (4) transmitting said pilot II from said RCS to said UV police authority and receiving, at said police authority, said pilot II (“received pilot II”);
- (5) said police authority utilizing a computational device to compare said received pilot II with said stored II of registered UV pilots; and
- (6) based on the results of said step (5), indicating at said police authority whether or not said UV pilot is a registered UV pilot.

129.-179. (canceled)

180. The method of claim **120**, wherein

said step (7) further comprises utilizing said computational device to analyze said combination of images (i), (ii) and (iii) to determine whether or not said hand and said biologic identifier belong to the same person, thereby to determine whether the person identified by said biologic identifier is the person inputting said control instruction.

181. The method defined in claim **117**, wherein said step (3) further comprises transmitting a request from said police authority to said UV for said UV pilot to input a first police-requested instruction (“PI”) to a RCS input device;

said step (4) further comprises transmitting said first requested PI from said UV to said RCS; and

said step (5) further includes transmitting a plurality of images showing:

- (i) a hand of said UV pilot actuating an input device for controlling said UV,
- (ii) at least one body part having a visible biologic identifier selected from the group consisting of: a face, a retina, an iris, a fingerprint and a palm print of said UV pilot, and

(iii) contiguous UV pilot body parts situated between said hand and said body part having said visible biologic identifier;

wherein said images allow an identification of said UV pilot actuating said input device;

said step (7) further includes utilizing said computational device to determine an inputted control instruction from said at least one image of the hand of said UV pilot actuating said input device;

and further comprising

a step (14) comparing said determined control instruction of said step (7) with said first requested PI;

whereby said police authority determines if said first requested PI was inputted by said UV pilot.

182. The method of claim **181**, wherein said step (7) further comprises utilizing said computational device to analyze said combination of images (i), (ii) and (iii) to determine whether or not said hand and said biologic identifier belong to the same person,

thereby to determine whether the person identified by said biologic identifier is the person inputting said control instruction.

183. The method of claim **123**, wherein said step (7) further comprises utilizing said computational device to analyze said combination of images (i), (ii) and (iii) to determine whether or not said hand and said biologic identifier belong to the same person,

thereby to determine whether the person identified by said biologic identifier is the person inputting said control instruction.

184. The method defined in claim **117**, wherein

said step (5) further includes transmitting data representing a control instruction inputted by said pilot from said RCS to said UV;

said step (6) further comprises transmitting (i) data represented by said control instruction from said UV to said police authority, and (ii) telemetry signals from said UV, indicating an effect of said control instruction, to said police authority;

said step (7) further includes utilizing said computational device to perform a first determination of an instruction, represented by said inputted control instruction by analyzing the effect of said inputted instruction on a motion of said UV;

and further comprising

a step (18) comparing said first determination based on said effected UV motion with said received control instruction;

whereby said police authority determines if said inputted control instruction is controlling said UV.

185. The method defined in claim **128**, wherein said biologic identification information is selected from the group consisting of (a) an image of a face; (b) an image of a retina; (c) an image of an iris; (d) an image of at least one fingerprint; (e) an image of a palm print; (f) a voice print; and (g) a DNA sample.

186. The method defined in claim **128**, wherein:

said step (4) further includes transmitting a plurality of images showing:

- (i) a hand of said UV pilot actuating an input device for controlling said UV,

(ii) at least one body part having a visible biologic identifier selected from the group consisting of: a face, a retina, an iris, a fingerprint and a palm print of said UV pilot, and

(iii) contiguous UV pilot body parts situated between said hand and said body part having said visible biologic identifier;

wherein an analysis of the combination of said images (i), (ii) and (iii) allow an identification of said UV pilot actuating said input device; and

said step (4) further includes transmitting data representing a control instruction from said RCS to said UV, and to said UV police authority;

and further comprising:

a step (7) utilizing said computational device to determine an inputted control instruction from said at least one image of the hand of said UV pilot actuating an input device;

a step (8) comparing the received control instruction with said determined control instruction of said step (7) and

a step (9) said police authority determining whether the vehicle under observation is being piloted by the pilot whose biologic identification has been inputted, in dependence upon whether said received control instruction substantially matches said determined control instruction.

187. The method of claim **186**, wherein said step (7) further comprises utilizing said computational device to analyze said combination of images (i), (ii) and (iii) to determine whether or not said hand and said biologic identifier belong to the same person,

thereby to determine whether the person identified by said biologic identifier is the person inputting said control instruction.

188. The method defined in claim **128**, wherein said step (3) further comprises transmitting a request from said police authority to said RCS for said UV pilot to input a first police-requested instruction ("PI") to a RCS input device;

said step (4) further includes transmitting data representing a control instruction for controlling a motion or an orientation of said UV, inputted by said pilot in response to said PI, from said RCS to said UV, and to said UV police authority;

and further comprising

a step (10) comparing an instruction represented by said police authority-received control instruction with said first requested PI; and

a step (11) said police authority determining if said first requested PI was inputted by said UV pilot.

189. The method defined in claim **128**, wherein said step (3) further comprises transmitting a request from said police authority to said RCS for said UV pilot to input a first police-requested instruction ("PI") to a RCS input device; and

said step (4) further includes transmitting a plurality of images showing:

(i) a hand of said UV pilot actuating an input device for controlling said UV,

(ii) at least one body part having a visible biologic identifier selected from the group consisting of: a face, a retina, an iris, a fingerprint and a palm print of said UV pilot, and

(iii) contiguous UV pilot body parts situated between said hand and said body part having said visible biologic identifier; wherein said images allow an identification of said UV pilot actuating said input device;

and further comprising

a step (12) utilizing said computational device to determine an inputted control instruction from said at least one image of the hand of said UV pilot actuating said input device; and

a step (13) comparing said determined control instruction of said step (12) with said first requested PI; whereby said police authority determines if said first requested PI was inputted by said UV pilot.

190. The method of claim **189**, wherein said step (12) further comprises utilizing said computational device to analyze said combination of images (i), (ii) and (iii) to determine whether or not said hand and said biologic identifier belong to the same person,

thereby to determine whether the person identified by said biologic identifier is the person inputting said control instruction.

191. The method defined in claim **128**, wherein said step (4) further includes transmitting a control instruction inputted by said pilot for controlling a motion or an orientation of said UV from said RCS to said UV; and

said step (4) further includes transmitting a plurality of images to said UV police authority, showing:

(i) a hand of said UV pilot actuating an input device for controlling said UV,

(ii) at least one body part having a visible biologic identifier selected from the group consisting of a face, a retina, an iris, a fingerprint and a palm print of said UV pilot, and

(iii) contiguous UV pilot body parts situated between said hand and said body part having said visible biologic identifier; wherein said images allow an identification of said UV pilot actuating said input device;

and further comprising

a step (14) transmitting telemetry signals from said UV, indicating an effect of said control instruction upon said UV, to said police authority;

a step (15) utilizing said computational device to perform a first determination of an instruction, represented by said inputted control instruction, by analyzing the effect of said inputted instruction on a motion of said UV;

a step (16) utilizing said computational device to perform a second determination of an instruction, represented by said inputted control instruction, by analyzing said at least one image of the hand of said UV pilot actuating said input device;

a step (17) of comparing said first determination based on said effected UV motion with said second determination based on an analysis of said at least one image of the hand of said UV pilot actuating said input device for controlling said UV; and

a step (18) said police authority determining whether the vehicle under observation is being piloted by the pilot whose biologic identification has been inputted, in dependence upon whether said first determination substantially matches said second determination.

192. The method of claim **191**, wherein said step (16) further comprises utilizing said computational device to analyze said combination of images (i), (ii) and (iii) to determine whether or not said hand and said biologic identifier belong to the same person,

thereby to determine whether the person identified by said biologic identifier is the person inputting said control instruction.

193. The method defined in claim **128**, wherein said step (3) further comprises transmitting a request from said police authority to said RCS for said pilot to input a second police-requested instruction (“PI”) to a RCS input device;

and further comprising:

a step (19) transmitting telemetry signals from said UV, indicating an effect of said requested instruction, to said police authority;

a step (20) utilizing said computational device to perform a first determination of an instruction, represented by said inputted control instruction, by analyzing the effect of said inputted instruction on a motion of said UV; and a step (21) comparing said first determination based on said effected UV motion with said second requested PI; whereby said police authority determines if said second requested PI was inputted by said UV pilot.

194. The method defined in claim **128**, wherein said step (4) further includes transmitting data representing a control instruction inputted by said pilot from said RCS to said UV;

and further comprising:

a step (22) transmitting data represented by said control instruction from said UV to said UV police authority;

a step (23) transmitting telemetry signals from said UV, indicating an effect of said control instruction, to said police authority;

a step (24) utilizing said computational device to perform a first determination of an instruction, represented by said inputted control instruction by analyzing the effect of said inputted instruction on a motion of said UV; and a step (25) comparing said first determination based on said effected UV motion with said received control instruction;

whereby said police authority determines if said inputted control instruction is controlling said UV.

195. The method defined in claim **128**, wherein said UV is selected from the group consisting of an unmanned aerial vehicle, an unmanned ground vehicle, and unmanned underwater vehicle, and an unmanned space vehicle.

196. The method of claim **128**, wherein said step (3) comprises the transmission of information directly from said police authority to said RCS.

197. The method of claim **128**, wherein said step (3) comprises the transmission of information from said police authority to said UV, followed by the transmission of said information from said UV to said RCS.

198. The method of claim **128**, wherein said step (4) comprises the transmission of information directly from said RCS to said police authority.

199. The method of claim **128**, wherein said step (4) comprises the transmission of information from said RCS to said UV, followed by the transmission of said information from said UV to said police authority.

* * * * *