



(19) **United States**

(12) **Patent Application Publication**
SHETTY et al.

(10) **Pub. No.: US 2018/0241632 A1**

(43) **Pub. Date: Aug. 23, 2018**

(54) **SYSTEMS AND METHODS FOR NETWORK TOPOLOGY DISCOVERY**

Publication Classification

(71) Applicant: **Dell Products L.P.**, Round Rock, TX (US)

(51) **Int. Cl.**
H04L 12/24 (2006.01)
H04L 12/721 (2006.01)

(72) Inventors: **Sudhir Vittal SHETTY**, Cedar Park, TX (US); **Sanjay SANE**, Fremont, CA (US); **Balaji RAJAGOPALAN**, Sunnyvale, CA (US); **Jacob R. HUTCHESON**, Round Rock, TX (US); **Prakash NARA**, Round Rock, TX (US); **Babu CHANDRASEKHAR**, Round Rock, TX (US)

(52) **U.S. Cl.**
CPC *H04L 41/12* (2013.01); *H04L 45/26* (2013.01); *H04L 41/22* (2013.01)

(73) Assignee: **Dell Products L.P.**, Round Rock, TX (US)

(57) **ABSTRACT**

(21) Appl. No.: **15/441,005**

An information handling system may include a processor, a memory coupled to the processor, the memory having program instructions stored thereon that, upon execution by the processor, cause the processor to: (i) responsive to a physical connection being made between components of a system comprising multiple information handling system chassis, receive a message; (ii) process information present in the message indicative of a topology of connectivity among the components of the system; and (iii) update a data structure defining the topology of connectivity of the various components of the system based on the information present in the message.

(22) Filed: **Feb. 23, 2017**

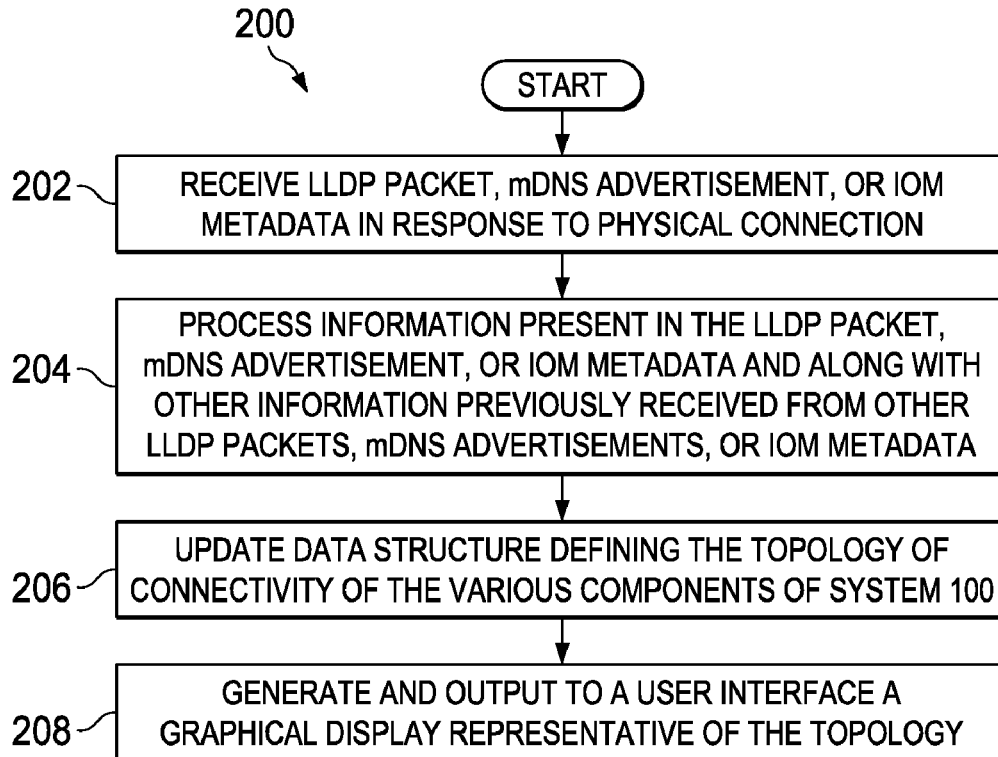

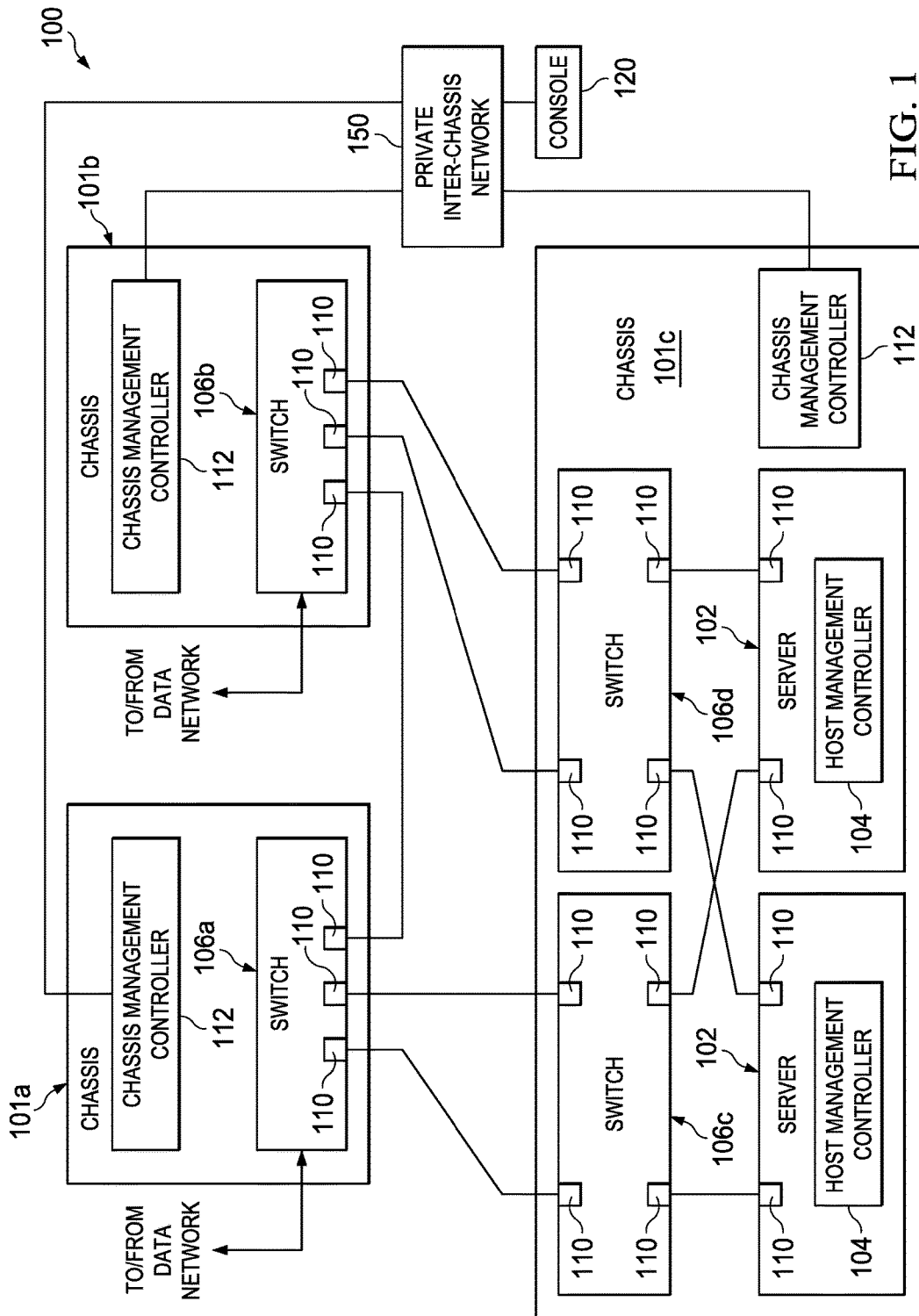

FIG. 1

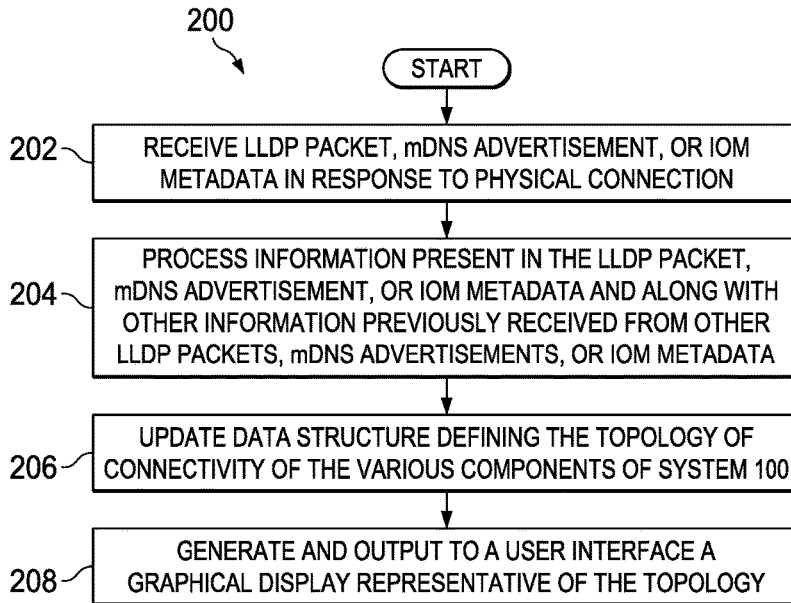

FIG. 2

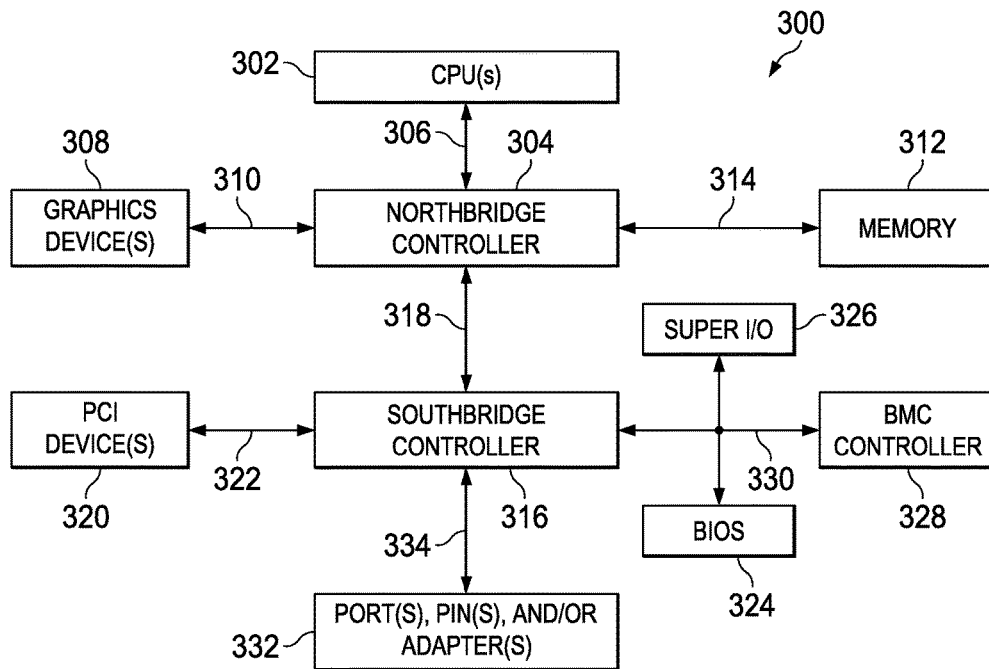

FIG. 3

SYSTEMS AND METHODS FOR NETWORK TOPOLOGY DISCOVERY

TECHNICAL FIELD

[0001] The present disclosure relates in general to information handling systems, and more particularly to providing for network topology discovery in a system comprising multiple information handling system chassis.

BACKGROUND

[0002] As the value and use of information continues to increase, individuals and businesses seek additional ways to process and store information. One option available to users is information handling systems. An information handling system generally processes, compiles, stores, and/or communicates information or data for business, personal, or other purposes thereby allowing users to take advantage of the value of the information. Because technology and information handling needs and requirements vary between different users or applications, information handling systems may also vary regarding what information is handled, how the information is handled, how much information is processed, stored, or communicated, and how quickly and efficiently the information may be processed, stored, or communicated. The variations in information handling systems allow for information handling systems to be general or configured for a specific user or specific use such as financial transaction processing, airline reservations, enterprise data storage, or global communications. In addition, information handling systems may include a variety of hardware and software components that may be configured to process, store, and communicate information and may include one or more computer systems, data storage systems, and networking systems.

[0003] In a system comprising multiple information handling system chassis, the various chassis may be of different types and may be cabled and wired together in a particular manner. A console for managing the system may need to determine the connectivity among the various chassis and components internal to the chassis in order to determine a topology of the system.

SUMMARY

[0004] In accordance with the teachings of the present disclosure, certain disadvantages and problems associated with determining a topology in a multi-chassis environment have been reduced or eliminated.

[0005] In accordance with embodiments of the present disclosure, an information handling system may include a processor, a memory coupled to the processor, the memory having program instructions stored thereon that, upon execution by the processor, cause the processor to: (i) responsive to a physical connection being made between components of a system comprising multiple information handling system chassis, receive a message; (ii) process information present in the message indicative of a topology of connectivity among the components of the system; and (iii) update a data structure defining the topology of connectivity of the various components of the system based on the information present in the message.

[0006] In accordance with these and other embodiments of the present disclosure, a method may include responsive to a physical connection being made between components of a

system comprising multiple information handling system chassis, receiving a message. The method may further include processing information present in the message indicative of a topology of connectivity among the components of the system. The method may also include updating a data structure defining the topology of connectivity of the various components of the system based on the information present in the message.

[0007] In accordance with these and other embodiments of the present disclosure, an article of manufacture may include a non-transitory computer readable medium and computer-executable instructions carried on the computer readable medium, the instructions readable by a processor, the instructions, when read and executed, for causing the processor to: (i) responsive to a physical connection being made between components of a system comprising multiple information handling system chassis, receive a message; (ii) process information present in the message indicative of a topology of connectivity among the components of the system; and (iii) update a data structure defining the topology of connectivity of the various components of the system based on the information present in the message.

[0008] Technical advantages of the present disclosure may be readily apparent to one skilled in the art from the figures, description and claims included herein. The objects and advantages of the embodiments will be realized and achieved at least by the elements, features, and combinations particularly pointed out in the claims.

[0009] It is to be understood that both the foregoing general description and the following detailed description are examples and explanatory and are not restrictive of the claims set forth in this disclosure.

BRIEF DESCRIPTION OF THE DRAWINGS

[0010] A more complete understanding of the present embodiments and advantages thereof may be acquired by referring to the following description taken in conjunction with the accompanying drawings, in which like reference numbers indicate like features, and wherein:

[0011] FIG. 1 illustrates a block diagram of a system comprising multiple information handling system chassis, in accordance with embodiments of the present disclosure;

[0012] FIG. 2 illustrates a flow chart of an example method for network topology discovery, in accordance with embodiments of the present disclosure; and

[0013] FIG. 3 illustrates a block diagram of an information handling system, in accordance with embodiments of the present disclosure.

DETAILED DESCRIPTION

[0014] Preferred embodiments and their advantages are best understood by reference to FIGS. 1 through 3, wherein like numbers are used to indicate like and corresponding parts. For the purposes of this disclosure, an information handling system may include any instrumentality or aggregate of instrumentalities operable to compute, classify, process, transmit, receive, retrieve, originate, switch, store, display, manifest, detect, record, reproduce, handle, or utilize any form of information, intelligence, or data for business, scientific, control, entertainment, or other purposes. For example, an information handling system may be a personal computer, a personal digital assistant (PDA), a consumer electronic device, a network storage device, or

any other suitable device and may vary in size, shape, performance, functionality, and price. The information handling system may include memory, one or more processing resources such as a central processing unit (“CPU”) or hardware or software control logic. Additional components of the information handling system may include one or more storage devices, one or more communications ports for communicating with external devices as well as various I/O devices, such as a keyboard, a mouse, and a video display. The information handling system may also include one or more buses operable to transmit communication between the various hardware components.

[0015] For the purposes of this disclosure, information handling resources may broadly refer to any component system, device or apparatus of an information handling system, including without limitation processors, buses, memories, I/O devices and/or interfaces, storage resources, network interfaces, motherboards, electro-mechanical devices (e.g., fans), displays, and power supplies.

[0016] For the purposes of this disclosure, computer-readable media may include any instrumentality or aggregation of instrumentalities that may retain data and/or instructions for a period of time. Computer-readable media may include, without limitation, storage media such as a direct access storage device (e.g., a hard disk drive or floppy disk), a sequential access storage device (e.g., a tape disk drive), compact disk, CD-ROM, DVD, random access memory (“RAM”), read-only memory (“ROM”), electrically erasable programmable read-only memory (“EEPROM”), and/or flash memory; as well as communications media such as wires, optical fibers, microwaves, radio waves, and other electromagnetic and/or optical carriers; and/or any combination of the foregoing.

[0017] FIG. 1 illustrates a block diagram of a system 100 comprising multiple information handling system chassis 101, in accordance with embodiments of the present disclosure. As depicted in FIG. 1, system 100 may comprise a plurality of chassis 101 (e.g. chassis 101a, 101b, and 101c), each chassis 101 including information handling systems and/or information handling resources, a private inter-chassis network 150, and a console 120. For example, chassis 101a may include a switch 106a and a chassis management controller 112. As another example, chassis 101b may include a switch 106b and a chassis management controller 112. As a further example, chassis 101c may include switches 106c and 106d, one or more servers 102, and a chassis management controller 112. The various servers 102 and switches 106 may each comprise ports 110 for interfaces with one another, with example connectivity among ports 110 depicted in FIG. 1. For the purposes of clarity and exposition, chassis 101a and 101b are shown without servers (e.g., servers 102). However, in some embodiments, one or both of chassis 101a and 101b may include one or more servers 102.

[0018] A server 102 may generally be operable to receive data from and/or communicate data to one or more information handling resources of chassis 101c. In certain embodiments, a server 102 may comprise a blade server having modular physical design. In these and other embodiments, server 102 may comprise an M class server.

[0019] Each server 102 may include a host management controller 104. Host management controller 104 may be implemented by, for example, a microprocessor, microcontroller, DSP, ASIC, EEPROM, or any combination thereof.

Host management controller 104 may be configured to communicate with chassis management controller 112. Such communication may be made, for example, via a private management network fabric integral to server 102 (not explicitly shown). Host management controller 104 may be configured to provide out-of-band management facilities for management of information handling system 102. Such management may be made by information handling resources of chassis 101 even if information handling system 102 is powered off or powered to a standby state. Host management controller 104 may include a processor, memory, and network connection separate from the rest of information handling system 102. In certain embodiments, host management controller 104 may include or may be an integral part of a baseboard management controller (BMC) or an Integrated Dell Remote Access Controller (iDRAC).

[0020] A switch 106 may comprise any suitable system, device, or apparatus for receiving, processing, and forwarding packets. For example, each of switch 106a and 106b may serve as an interface between chassis 101c and a data network and may process and route packets between chassis 101c and such data network. As another example, switches 106c and 106d may each serve as an interface between servers 102 and other chassis 101 (e.g., 101a and 101b) external to chassis 101c.

[0021] Each port 110 may comprise a connector, slot, or another interface for receiving one end of a physical connection (e.g., wire, cable) coupled to a corresponding port 110 of another information handling resource.

[0022] A chassis management controller 112 may comprise any system, device, or apparatus configured to facilitate management and/or control of system 100 embodied by chassis 101, its information handling systems 102, and/or one or more of its component information handling resources. Chassis management controller 112 may be configured to issue commands and/or other signals to manage and/or control an information handling system 102 and/or information handling resources of system 100. Chassis management controller 112 may comprise a microprocessor, microcontroller, DSP, ASIC, field programmable gate array (“FPGA”), EEPROM, or any combination thereof. In some embodiments, chassis management controller 112 may provide a management console for user/administrator access to these functions. For example, chassis management controller 112 may implement Representational State Transfer (“REST”) or another suitable management protocol permitting a user to remotely access chassis management controller 112 to configure system 100 and its various information handling resources. In such embodiments, chassis management controller 112 may interface with a network interface, thus allowing for “out-of-band” control of chassis 101, such that communications to and from chassis management controller 112 are communicated via a management channel physically isolated from an “in-band” communication channel of chassis 101 for which non-management communication may take place. Thus, for example, if a failure occurs in chassis 101 that prevents an administrator from interfacing with chassis 101 via the in-band communication channel or a user interface associated with chassis 101 (e.g., power failure, etc.), the administrator may still be able to monitor and/or manage chassis 101 (e.g., to diagnose problems that may have caused failure) via chassis management controller 112. In the same or alternative embodiments, chassis management controller 112 may allow an administrator to

remotely manage one or more parameters associated with operation of chassis **101** and its various information handling resources (e.g., power usage, processor allocation, memory allocation, security privileges, etc.). In some embodiments, chassis management controller **112** may include a management services module. Although beyond the scope of this disclosure, in some embodiments, one of the chassis management controllers **112** of the various chassis **101** may be selected as a “lead” chassis management controller **112**, such that an administrator may manage the entirety of system **100** by interfacing with a single chassis management controller **112**.

[0023] Private inter-chassis network **150** may comprise a network and/or fabric configured to couple information chassis management controllers **112** of the various chassis **101** in system **100** to each other. In these and other embodiments, inter-chassis network **150** may include a communication infrastructure, which provides physical connections, and a management layer, which organizes the physical connections and chassis management controllers **112** communicatively coupled to private inter-chassis network **150**. Private inter-chassis network **150** may be implemented as, or may be a part of, an Ethernet local area network (LAN) or any other appropriate architecture or system that facilitates the communication of signals, data, and/or messages.

[0024] Console **120** may be communicatively coupled to private inter-chassis network **150** and may comprise an information handling system or a program executable on an information handling system for monitoring and management of the various chassis **101** of system **100** and their various components. For example, as described in greater detail below, console **120** may be able to, based on messages communicated among chassis **101** and management controllers **112**, determine the topology of connectivity among the various components of system **100**. In some embodiments, console **120** may also be capable of rendering a graphical representation of the topology of connectivity to a user via a user interface (not explicitly shown) of console **120**. Although FIG. 1 depicts console **120** as a stand-alone component of system **100**, in some embodiments, console **120** may be integral to or otherwise embodied in a chassis management controller **112**.

[0025] In operation, console **120** may leverage payload information of packets (e.g., Link Layer Discovery Protocol or “LLDP” packets) communicated among switches **106** and/or servers **102** in response to a switch **106** or server **102** being coupled to another device in system **100** and may also leverage advertisements (e.g., multicast Domain Name Service or mDNS) communicated via private inter-chassis network **150** in order to extract information from such payloads and advertisements and process such information to determine topology of connectivity of devices of system **100**.

[0026] For example, in response to a server **102** being added to system **100**, a host management controller **104** of such server may communicate LLDP packets which may be received not only by switches **106c** and **106d** of the chassis **101c** comprising the server **102**, but may be also passed-through from switches **106c** and **106d** to switches **106a** and **106b** of chassis **101a** and **101b**, respectively. The payload of each such LLDP packet may include various identifying information, including without limitation identifying information (e.g., service tag or serial number) of the server **102** from which the LLDP packet originated, identifying infor-

mation (e.g., service tag or serial number) of the chassis **101** comprising the server **102**, identifying information (e.g., fully-qualified device descriptor) of the port **110** of the server **102** originating the LLDP packet, and the switch fabric (e.g., **106c** or **106d**) to which the packet-originating port **110** is coupled. Thus, based on such payload, a console **120** may be able to determine the chassis **101** housing the server **102**, a switch fabric to which the server **102** is coupled, and connectivity between the server **102** and a switch **106** receiving the LLDP packet external to the chassis **101**.

[0027] As another example, chassis management controllers **112** may communicate mDNS advertisements on private inter-chassis network **150**. Such advertisements may include various identifying information, including without limitation identifying information (e.g., service tag or serial number) of a chassis **101** including a switch fabric, identifying information (e.g., slot number) of a switch **106** of the switch fabric, and a switch type for the switch **106**. Accordingly, console **120** may correlate such information from mDNS advertisements to the information from LLDP payloads to determine the switch type of each switch fabric.

[0028] As a further example, a switch **106** may include metadata information (e.g., an I/O module or “IOM” descriptor file) that is specific to a switch type and uplink (e.g., connectivity between a server and switch **106c/106d**) and downlink connectivity (connectivity between a switch **106c/106d** and a switch **106a/106b**) of a switch **106**. Accordingly, console **120** may correlate such IOM metadata information to information from mDNS advertisements and/or information from LLDP payloads to determine the complete topology of each switch fabric.

[0029] Inter-switch connectivity (e.g., between switches **106a** and **106b**) and external network connectivity (e.g., between an external data network and switches **106a/106b**) may be determined based on LLDP payloads communicated between switches (e.g., between switches **106a** and **106b**) and between individual switches (e.g., between switches **106a** and **106b**) and the external data network.

[0030] FIG. 2 illustrates a flow chart of an example method **200** for network topology discovery, in accordance with embodiments of the present disclosure. According to some embodiments, method **200** may begin at step **202**. As noted above, teachings of the present disclosure may be implemented in a variety of configurations of system **100**. As such, the preferred initialization point for method **200** and the order of the steps comprising method **200** may depend on the implementation chosen.

[0031] At step **202**, console **120** may receive an LLDP packet, mDNS advertisement, or IOM metadata in response to a physical connection being made in system **100**. At step **204**, console **120** may process information present in the LLDP packet, mDNS advertisement, or IOM metadata and along with other information previously received from other LLDP packets, mDNS advertisements, or IOM metadata. At step **206**, based on such processing, console **120** may update a table, list, map, database, or other data structure defining the topology of connectivity of the various components of system **100**. At step **208**, in some embodiments, console **120** may generate and output to a user interface a graphical display representative of the topology.

[0032] Although the foregoing contemplates that console **120** receives various traffic, it is noted that console **120** may not receive all of such traffic (e.g., console **120** may not

receive LLDP packets). Instead, a switch 106 may receive LLDP packets and determine topology based on such packets. Thus, a complete topology of a system may be determined by the aggregate of traffic received by switches 106 and console 120.

[0033] Although FIG. 2 discloses a particular number of steps to be taken with respect to method 200, method 200 may be executed with greater or lesser steps than those depicted in FIG. 2. In addition, although FIG. 2 discloses a certain order of steps to be taken with respect to method 200, the steps comprising method 200 may be completed in any suitable order.

[0034] Method 200 may be implemented using system 100, and/or any other system operable to implement method 200. In certain embodiments, method 200 may be implemented partially or fully in software and/or firmware embodied in computer-readable media.

[0035] FIG. 3 illustrates a block diagram of an information handling system 300, in accordance with embodiments of the present disclosure. Information handling system 300 is an instance of console 120 and/or a server 102 illustrated in FIG. 1. As shown, information handling system 300 includes one or more CPUs 302. In various embodiments, information handling system 300 may be a single-processor system including one CPU 302, or a multi-processor system including two or more CPUs 302 (e.g., two, four, eight, or any other suitable number). CPU(s) 302 may include any processor capable of executing program instructions. For example, in various embodiments, CPU(s) 302 may be general-purpose or embedded processors implementing any of a variety of instruction set architectures (ISAs), such as the x86, POWERPC, ARM, SPARC, or MIPS ISAs, or any other suitable ISA. In multi-processor systems, each of CPU(s) 302 may commonly, but not necessarily, implement the same ISA. In such an embodiment, a motherboard may be configured to provide structural support, power, and electrical connectivity between the various aforementioned components. Such a motherboard may include multiple connector sockets in various configurations, adapted to receive pluggable circuit cards, component chip packages, etc.

[0036] CPU(s) 302 are coupled to northbridge controller or chipset 304 via front-side bus 306. Northbridge controller 304 may be configured to coordinate I/O traffic between CPU(s) 302 and other components. For example, in this particular implementation, northbridge controller 304 is coupled to graphics device(s) 308 (e.g., one or more video cards or adaptors, etc.) via graphics bus 310 (e.g., an Accelerated Graphics Port or AGP bus, a Peripheral Component Interconnect or PCI bus, etc.). Northbridge controller 304 is also coupled to system memory 312 via memory bus 314. Memory 312 may be configured to store program instructions and/or data accessible by CPU(s) 302. In various embodiments, memory 312 may be implemented using any suitable memory technology, such as static RAM (SRAM), synchronous dynamic RAM (SDRAM), nonvolatile/Flash-type memory, or any other type of memory.

[0037] Northbridge controller 304 is coupled to southbridge controller or chipset 316 via internal bus 318. Generally, southbridge controller 316 may be configured to handle various of computing device information handling system 300's I/O operations, and it may provide interfaces such as, for instance, Universal Serial Bus (USB), audio, serial, parallel, Ethernet, etc., via port(s), pin(s), and/or

adapter(s) 332 over bus 334. For example, southbridge controller 316 may be configured to allow data to be exchanged between information handling system 300 and other devices, such as other information handling systems attached to a network. In various embodiments, southbridge controller 316 may support communication via wired or wireless general data networks, such as any suitable type of Ethernet network, for example; via telecommunications/telephony networks such as analog voice networks or digital fiber communications networks; via storage area networks such as Fiber Channel SANs; or via any other suitable type of network and/or protocol.

[0038] Southbridge controller 316 may also enable connection to one or more keyboards, keypads, touch screens, scanning devices, voice or optical recognition devices, or any other devices suitable for entering or retrieving data. Multiple I/O devices may be present in information handling system 300. In some embodiments, I/O devices may be separate from information handling system 300 and may interact with information handling system 300 through a wired or wireless connection. As shown, southbridge controller 316 is further coupled to one or more PCI devices 320 (e.g., modems, network cards, sound cards, video cards, etc.) via PCI bus 322. Southbridge controller 316 is also coupled to Basic I/O System (BIOS) 324, Super I/O Controller 326, and Baseboard Management Controller (BMC) 328 via Low Pin Count (LPC) bus 330.

[0039] BIOS 324 includes non-volatile memory having program instructions stored thereon. Those instructions may be usable for CPU(s) 302 to initialize and test other hardware components and/or to load an Operating System (OS) onto information handling system 300. As such, BIOS 324 may include a firmware interface that allows CPU(s) 302 to load and execute certain firmware, as described in more detail below. In some cases, such firmware may include program code that is compatible with the Unified Extensible Firmware Interface (UEFI) specification, although other types of firmware may be used.

[0040] BMC controller 328 may include non-volatile memory having program instructions stored thereon that are usable by CPU(s) 302 to enable remote management of information handling system 300. For example, BMC controller 328 may enable a user to discover, configure, and manage BMC controller 328, setup configuration options, resolve and administer hardware or software problems, etc. Additionally or alternatively, BMC controller 328 may include one or more firmware volumes, each volume having one or more firmware files used by the BIOS' firmware interface to initialize and test components of information handling system 300.

[0041] Super I/O Controller 326 combines interfaces for a variety of lower bandwidth or low data rate devices. Those devices may include, for example, floppy disks, parallel ports, keyboard and mouse, temperature sensor and fan speed monitoring, etc. For example, the super I/O controller 326 may be coupled to the one or more upstream sensors and to the one or more downstream sensors.

[0042] In some cases, information handling system 300 may be configured to access different types of computer-accessible media separate from memory 312. Generally speaking, a computer-accessible medium may include any tangible, non-transitory storage media or memory media such as electronic, magnetic, or optical media—e.g., magnetic disk, a hard drive, a CD/DVD-ROM, a Flash memory,

etc. coupled to information handling system **300** via northbridge controller **304** and/or southbridge controller **316**.

[0043] As used herein, when two or more elements are referred to as “coupled” to one another, such term indicates that such two or more elements are in electronic communication or mechanical communication, as applicable, whether connected indirectly or directly, with or without intervening elements.

[0044] This disclosure encompasses all changes, substitutions, variations, alterations, and modifications to the example embodiments herein that a person having ordinary skill in the art would comprehend. Similarly, where appropriate, the appended claims encompass all changes, substitutions, variations, alterations, and modifications to the example embodiments herein that a person having ordinary skill in the art would comprehend. Moreover, reference in the appended claims to an apparatus or system or a component of an apparatus or system being adapted to, arranged to, capable of, configured to, enabled to, operable to, or operative to perform a particular function encompasses that apparatus, system, or component, whether or not it or that particular function is activated, turned on, or unlocked, as long as that apparatus, system, or component is so adapted, arranged, capable, configured, enabled, operable, or operative.

[0045] All examples and conditional language recited herein are intended for pedagogical objects to aid the reader in understanding the disclosure and the concepts contributed by the inventor to furthering the art, and are construed as being without limitation to such specifically recited examples and conditions. Although embodiments of the present disclosure have been described in detail, it should be understood that various changes, substitutions, and alterations could be made hereto without departing from the spirit and scope of the disclosure.

What is claimed is:

1. An information handling system comprising:
 - a processor;
 - a memory coupled to the processor, the memory having program instructions stored thereon that, upon execution by the processor, cause the processor to:
 - responsive to a physical connection being made between components of a system comprising multiple information handling system chassis, receive a message;
 - process information present in the message indicative of a topology of connectivity among the components of the system; and
 - update a data structure defining the topology of connectivity of the various components of the system based on the information present in the message.
2. The information handling system of claim **1**, the instructions for further causing the processor to generate a graphical display to a user interface representative of the topology of connectivity.
3. The information handling system of claim **1**, the instructions for further causing the processor to update the data structure based on the information present in the message and previous messages generated in response to other physical connections being made between components of the system.
4. The information handling system of claim **1**, wherein the message comprises a message communicated from another information handling system integral to a first one of

the multiple information handling system chassis to a second one of the multiple information handling system chassis.

5. The information handling system of claim **1**, wherein the message comprises a Link Layer Discovery Protocol packet.

6. The information handling system of claim **1**, wherein the message comprises an advertisement communicated on a private inter-chassis network communicatively coupled to each of the multiple information handling system chassis, wherein the private inter-chassis network is configured to carry network traffic for managing the multiple information handling system chassis.

7. The information handling system of claim **1**, wherein the message comprises a multicast Domain Name Service advertisement.

8. The information handling system of claim **1**, wherein the message comprises metadata associated with a switch fabric.

9. The information handling system of claim **1**, wherein the message comprises an input/output module descriptor file.

10. A method comprising:

- responsive to a physical connection being made between components of a system comprising multiple information handling system chassis, receiving a message;
- processing information present in the message indicative of a topology of connectivity among the components of the system; and
- updating a data structure defining the topology of connectivity of the various components of the system based on the information present in the message.

11. The method of claim **10**, further comprising generating a graphical display to a user interface representative of the topology of connectivity.

12. The method of claim **10**, further comprising updating the data structure based on the information present in the message and previous messages generated in response to other physical connections being made between components of the system.

13. The information handling system of claim **10**, wherein the message comprises a message communicated from another information handling system integral to a first one of the multiple information handling system chassis to a second one of the multiple information handling system chassis.

14. The information handling system of claim **10**, wherein the message comprises a Link Layer Discovery Protocol packet.

15. The information handling system of claim **10**, wherein the message comprises an advertisement communicated on a private inter-chassis network communicatively coupled to each of the multiple information handling system chassis, wherein the private inter-chassis network is configured to carry network traffic for managing the multiple information handling system chassis.

16. The information handling system of claim **10**, wherein the message comprises a multicast Domain Name Service advertisement.

17. The information handling system of claim **10**, wherein the message comprises metadata associated with a switch fabric.

18. The information handling system of claim **10**, wherein the message comprises an input/output module descriptor file.

19. An article of manufacture comprising:
a non-transitory computer readable medium; and
computer-executable instructions carried on the computer
readable medium, the instructions readable by a pro-
cessor, the instructions, when read and executed, for
causing the processor to:

responsive to a physical connection being made
between components of a system comprising mul-
tiple information handling system chassis, receive a
message;

process information present in the message indicative
of a topology of connectivity among the components
of the system; and

update a data structure defining the topology of con-
nectivity of the various components of the system
based on the information present in the message.

20. The article of claim **19**, the instructions for further
causing the processor to generate a graphical display to a
user interface representative of the topology of connectivity.

* * * * *