

(19) World Intellectual Property Organization
International Bureau



(43) International Publication Date
6 March 2003 (06.03.2003)

PCT

(10) International Publication Number
WO 03/019883 A2

- (51) International Patent Classification⁷: **H04L 12/58**, 29/06, 12/24
- (21) International Application Number: PCT/EP02/09035
- (22) International Filing Date: 13 August 2002 (13.08.2002)
- (25) Filing Language: English
- (26) Publication Language: English
- (30) Priority Data:
01870183.9 24 August 2001 (24.08.2001) EP
- (71) Applicant (for all designated States except US): **WINDMILL MICROSYSTEMS HOLDING BV** [NL/NL]; Beurtschipper 20, NL-3861 SC Nijkerk (NL).
- (81) Designated States (national): AE, AG, AL, AM, AT, AU, AZ, BA, BB, BG, BR, BY, BZ, CA, CH, CN, CO, CR, CU, CZ, DE, DK, DM, DZ, EC, EE, ES, FI, GB, GD, GE, GH, GM, HR, HU, ID, IL, IN, IS, JP, KE, KG, KP, KR, KZ, LC, LK, LR, LS, LT, LU, LV, MA, MD, MG, MK, MN, MW, MX, MZ, NO, NZ, OM, PH, PL, PT, RO, RU, SD, SE, SG, SI, SK, SL, TJ, TM, TN, TR, TT, TZ, UA, UG, US, UZ, VN, YU, ZA, ZM, ZW.
- (84) Designated States (regional): ARIPO patent (GH, GM, KE, LS, MW, MZ, SD, SL, SZ, TZ, UG, ZM, ZW), Eurasian patent (AM, AZ, BY, KG, KZ, MD, RU, TJ, TM), European patent (AT, BE, BG, CH, CY, CZ, DE, DK, EE, ES, FI, FR, GB, GR, IE, IT, LU, MC, NL, PT, SE, SK, TR), OAPI patent (BF, BJ, CF, CG, CI, CM, GA, GN, GQ, GW, ML, MR, NE, SN, TD, TG).

- (72) Inventor; and
- (75) Inventor/Applicant (for US only): **VAN DALEN, Rutger, H.J.** [NL/NL]; Corlaerstraat 6, NL-3863 ZD Nijkerk (NL).
- (74) Agent: **BRANTS, Johan, Philippe, Emile**; De Clercq, Brants & partners cv, Edgard Gevaertdreef 10a, B-9830 Sint-Martens-Latem (BE).

Published:

— without international search report and to be republished upon receipt of that report

For two-letter codes and other abbreviations, refer to the "Guidance Notes on Codes and Abbreviations" appearing at the beginning of each regular issue of the PCT Gazette.



WO 03/019883 A2

(54) Title: SYSTEM FOR REMOTE DATA ACQUISITION BASED ON E-MAIL MESSAGE COMMUNICATION THROUGH PUBLIC AND PRIVATE NETWORKS

(57) Abstract: The present invention relates to a method for transferring generic data acquired at a remote location to a central database based on e-mail communication, comprising the steps of: a. encapsulating the acquired data in an electronic mail message; and b. sending the electronic mail through a network (public or private) to a central database server; and c. extracting the data from the electronic mail message by the central database server; and d. storing the extracted data in the central database, whereby said acquired data is communicated directly to said database server by providing an architecture for Internet communication software for embedded platforms, said architecture being based on a network of software multiplexers and demultiplexers, controlled by an integrated protocol engine.

System for remote data acquisition based on e-mail message communication through public and private networks

The invention relates to a method and client apparatus for directly transferring generic data acquired at a remote location to a central database through a public or private network based on e-mail communication.

The invention further relates to a scalable and modular TCP/IP protocol stack architecture designed for said method.

The invention further relates to a server definition for said method.

The invention further relates to a serial communication architecture for configuration of said apparatus.

The invention further relates to an e-mail communication method for remote management of said apparatus.

DESCRIPTION

Field of the invention

The invention relates to a method for generic remote data acquisition, TCP/IP protocol stack architecture, application programming interface, apparatus therefor, and a serial communication architecture for configuration of said apparatus.

In a first aspect the present invention relates to a method and apparatus of transferring generic data acquired at a remote location to a central database by:

1. Encapsulating the data acquired by said apparatus in an electronic mail message,
 2. Sending the electronic mail message by said apparatus through a network (public or private) to a central database server,
 3. Extracting the data from the electronic mail message by the central database server,
 4. Storing the extracted data in the designated database,
- where all communication complies with Internet standards.

The preferred embodiment of the invention is referred to as bf3RDAQ data acquisition method and bf3RDAQ data acquisition client device.

New is that the method and apparatus allow development of any remote data acquisition without any limitation on applications or the nature of the data by providing a transparent database interface and modular design architecture approach for said applications.

A second aspect of the invention relates to a scalable and modular TCP/IP protocol stack architecture designed for the client-side Internet communication of the bf3RDAQ remote data acquisition application, and other applications, which incorporate Internet-type communication. Such architecture enables the bf3RDAQ data acquisition client application to communicate directly with the bf3RDAQ server.

A third aspect of the invention relates to a communication architecture for configuration and maintenance of the data acquisition client application, and other (embedded) applications.

A fourth aspect of the invention relates to an e-mail communication method for remote management of the data acquisition client application by the server.

A fifth aspect of the invention relates to an HTML based configuration interface which is accessible through the communications interface of the data acquisition client device.

The sixth aspect of the invention relates to FTP-based or HTTP-based updating of the data acquisition client software.

The seventh aspect invention relates to a definition for a cable which integrates RS232-to-TTL signal level conversion.

Background of the invention

Currently, architectures for remote data acquisition applications are either based on proprietary communication protocols or infrastructures, or both. In many cases, custom hardware is developed to acquire the data and send it to the server application. This has four important disadvantages:

1. Proprietary protocols require extensive development and testing, both on the client and server end.
2. Proprietary infrastructures are expensive in terms of development, implementation and maintenance, and often require great effort in achieving general acceptance.
3. Long-distance data transfer is either impossible, or requires conversion to other communication protocols (e.g. Public Switched Telephone Network).
4. Custom hardware implementations require extensive development and testing, and offers little reuse possibilities.

The first and second item make development of remote data acquisition applications unnecessary expensive, and both may imply a great development risk.

The third item makes developing applications which collect data from scattered locations in large areas (e.g. the global inventory or sales sites of a company) extremely difficult, and expensive.

5 The fourth item increases the overall development time of the application, and the limited reuse possibility results in additional cost to the application.

Methods for transferring collected data by means of email messages have been described in the art. EP 1,045,549 describes a method for monitoring and management of distributed networks. The performance data is gathered by a designated served in each network, which sends the accumulated performance data to one or more central servers. The
10 central servers together constitute the supervisory system for monitoring and management of the distributed networks.

EP 964,325 describes a method for managing field devices in industrial process systems.

Both above-described methods are based on a gateway architecture. In the method
15 according to EP 1,045,549, for instance, a designated server in the client network assumes the gateway architecture task: it collects the data from the hosts in the client network and transfers the accumulated data to the central server. In the method according to EP 964,325 field devices submit data to a gateway through proprietary or non-Internet protocols. The gateway processes and formats the data and forwards this data to a central server on behalf
20 of the field devices, which stores the received data in a database.

However, the use of a gateway architecture requires extensive development and testing and involves a time-consuming process.

Also, both above-described methods relate to particular fields of application. The method described in EP 1,045,549 is related to the management of distributed networks,
25 while the method described in EP 964,325 is related to the management of field devices in an industrial process system. Neither of the cited documents claims a method for remote acquisition of generic data.

To avoid the difficulties and drawbacks of the prior art methods, it would be desirable to provide a method and apparatus which reduce the time and effort required for the
30 development of remote data acquisition applications. Also, it would be advantageous to provide a method and apparatus, which enable the acquisition of generic data at a remote location, without limitations on the nature of the data or on applications.

The invention provides therefor a method according to claim 1. The apparatus of the invention is given in claim 2. Preferred embodiments of the invention are given in claims 3 to 5.

5 Regarding the second aspect of the invention, currently, architectures of TCP/IP protocol stacks for embedded applications are usually based on a model of stacked protocol layers. This model is derived from conventional design concepts used for high-performance processor environments. As such, it is not well suited for embedded applications which are based on processors with limited processing bandwidth and memory resources. The TCP/IP communication architecture of the present invention provides a modular and scalable concept
10 for the development of embedded systems with Internet connectivity. The preferred embodiment of the invention is given in claim 6.

Regarding the third aspect of the invention, currently, configuration interfaces for embedded applications are generally developed on a per-application basis. Because developing and testing the underlying communication is a time-consuming task, it increases
15 the development risk. The serial communication architecture of the present invention allows development times of configuration interfaces, which are significantly shortened. The preferred embodiments of the invention are given in claims 7 to 11.

Regarding the fourth aspect of the invention, currently, management of remote systems from a central location is usually implemented with custom applications. By making
20 use of the e-mail communication method of the present invention, the same architecture which is used for the remote data acquisition application can be used for management of the client data acquisition apparatus. The client-server nature of such architecture enables the data acquisition client application to communicate directly with the server. The preferred embodiment of the invention is given in claim 12.

25 Regarding the fifth aspect of the invention, currently, configuration and management of data acquisition clients from a remote device is usually done with custom hardware, software and protocols. By making use of an embedded HTTP server (web server), the configuration and management interface for access from a remote device can be based on TCP/IP communication and be implemented with a standard HTTP client (web browser), such
30 as Microsoft Internet Explorer. The preferred embodiment of the invention is given in claim 13.

Regarding the sixth aspect of the invention, currently, the updating of software versions from remote locations is usually performed with proprietary bootloader protocols. By making use of the FTP protocol, the software update can be based on TCP/IP communication

and be implemented with any FTP-compliant server. The preferred embodiment of the invention is given in claim 14.

Regarding the seventh aspect of the invention, currently RS-232-to-TTL signal level conversion is either provided by the embedded system hardware, or through additional external conversion circuitry. By integrating this function in the cable connector, the total product cost and the system complexity can be reduced. The preferred embodiment of the invention is given in claim 15.

Summary of the invention

The present invention is a system, method and apparatus (consisting of hardware, firmware and software) for transferring generic data acquired by said apparatus from a remote location to a central database.

The system of the present invention consists of a central database server, and a number of bf3RADQ data acquisition clients, which can establish communication connections to the server through any network which is capable of accommodating Internet communication. The data acquisition clients process and store the locally acquired data until it needs to be conveyed to the server application. The server application has access to the database.

Importantly, the system, method and apparatus according to the invention are suitable for acquiring generic data, without any limitations for application or the nature of the data.

An essential feature of the invention is the fact that the bf3RADQ data acquisition clients can establish direct communication connections to the server by using a client-server architecture. The system, method and apparatus according to the invention do not require the use of gateway architecture.

Another essential feature of the invention is the use of electronic mail for the encapsulation of the acquired data, and for transferring the encapsulated acquired data to the central server which hosts or connects to the target database. For physical layer communication, any network which allows Internet communication (e.g. LAN, WAN) can be used. This implies that any remote data acquisition application can be based on existing infrastructures and widely accepted (Internet) communication standards. It therefore is a new genuine universal data acquisition method and system, not based on proprietary communication concepts or infrastructures.

The apparatus provides the following functions:

1. Generic data processing (incl. RAM and ROM for data/program storage)
2. Physical layer communications interface (e.g. V.series modem, Ethernet, ISDN)

3. Real-time clock
4. Power-management
5. Non-volatile data storage
6. Interfaces with the data acquisition hardware (e.g. SPI, I²C)
- 5 7. UART serial interface

By providing a well-defined application programming interface API, the development of the remote data acquisition client is limited to the application-specific hardware and software.

The second aspect of the present invention is the architecture on which the client application Internet communication software is based. Rather than following a conventional stack model, the bf3Net Internet communication software is based on a design approach which is used in designing hardware signal routing structures. The bf3Net Internet communication architecture (TCP/IP communication architecture) of the present invention is based on a network of multiplexers and demultiplexers controlled by an embedded protocol engine. This architecture has the following advantages:

1. It is platform-independent (processor or operating system),
2. It is well-structured and modular
3. It is highly configurable
4. It is well-suited for embedded applications

By providing such an Internet communication architecture, data acquisition clients can be tailored and optimized for the application requirements. The same applies for other embedded applications.

The third aspect of the present invention is the bf3Scp serial communication architecture with which the bf3RDAQ data acquisition client can be configured through the UART serial interface provided by the apparatus of the invention. The chosen architecture has the following advantages:

1. The communication protocol is implemented by a host and target protocol engine, which can be reused for every application.
2. The development of the host implementation of the configuration interface is limited to the user interface functions (e.g. Windows user interface elements with underlying functions).
3. The development of the target application is limited to the processing of the received messages, and providing a reply.

It is mentioned that for other embedded applications the serial communication architecture of the present invention can be used as well.

An essential feature of the invention is the use of a target database which contains all the parameters associated with the target application (e.g. timing parameters and message
5 identifiers). By identifying the target application with the following, globally unique, identifiers:

1. 32-bit vendor identifier,
2. 32-bit application identifier,

these parameters can be retrieved from the target database. In particular, sets of messages can be assigned to a target application. The target unit can further be identified by
10 a 32-bit serial number.

The fourth aspect of the invention is a method for indirect configuration of the data acquisition client by the server application. The bf3RDAQ data acquisition client can be configured to retrieve electronic mail messages from its mailbox at the server by means of the POP3 protocol. These messages contain configuration data, which the POP3 client evaluates
15 to adjust their locally stored configuration settings. Advantageously, as mentioned above, by making use of the e-mail communication method of the present invention, the same TCP/IP communication architecture that is used for the remote data acquisition application can be used for management of the client data acquisition apparatus.

The fifth aspect of the invention is a method for direct configuration of the bf3RDAQ
20 data acquisition client from a remote location. A person or machine can establish an Internet-based communication session based on the TCP/IP communication architecture with the bf3RDAQ client through the network to which both connect. By interacting through an HTML file which is served by the bf3RDAQ data acquisition client embedded HTTP server, the configuration and status settings can be monitored or adjusted.

25 The sixth aspect of the invention is a method for updating of the data acquisition client software version by downloading a software image from the central server with the FTP or HTTP protocol. By making use of the FTP protocol, the software update can be based on TCP/IP communication and be implemented with any FTP-compliant server.

The seventh aspect of the invention is a serial communications cable with integrated
30 RS232-to-TTL signal level conversion.

Brief description of the drawings

In the drawings three sets of figures are given. The same reference numbers have been used for each of the separate sets 1, 2 and 3. Figures 1, 2 and 3 respectively are illustrations of embodiments of the first, second and third aspect of the invention.

5 Figure 1.A is a system overview of the bf3RDAQ remote data acquisition system according to the present invention, including two (2) bf3RDAQ data acquisition clients [DAC1] and [DAC2] at the remote locations, and a bf3RDAQ data acquisition server [DAS1], all with access and connected to the same Internet Protocol-compatible network.

10 Figure 1.B is a decomposition of all the elements which together constitute the bf3RDAQ remote data acquisition system according to the present invention.

Figure 1.C is a functional block diagram of an embodiment of a bf3RDAQ data acquisition client [DAC3], according to the present invention.

Figure 1.D is an architecture diagram of the bf3RDAQ data acquisition client application software [AS1], according to the present invention.

15 Figure 1.E is an architecture diagram of the bf3RDAQ data acquisition server application software [AS2], according to the present invention.

Figure 2.A is a general architecture diagram [AD1] of the bf3Net Internet communication software, according to the present invention.

20 Figure 2.B shows the layout of the path descriptor within the bf3Net Internet communication software, according to the present invention.

Figure 2.C is a datalink architecture diagram [AD2] of the bf3Net Internet communication software for Point-to-Point Protocol (PPP) connections, according to the present invention.

25 Figure 2.D is a datalink architecture diagram [AD3] of the bf3Net Internet communication software for Ethernet connections, according to the present invention.

Figure 3.A is a system overview of a configuration interface application based on the bf3Scp serial communication architecture, according to the present invention.

30 Figure 3.B is a protocol layer model of a bf3Scp communication session between a host and target implementation based on the bf3Scp serial communication architecture, according to the present invention.

Figure 3.C is the datagram format of the messages of the bf3Scp serial communication architecture, according to the present invention.

Figure 3.D is the datalink establishment procedure of the bf3Scp serial communication architecture, according to the present invention.

Figure 3.E is the datagram exchange procedure of the bf3Scp serial communication architecture, according to the present invention.

Figure 3.F is the block diagram of an embodiment of the communication cable with integrated signal conversion, according to the present invention.

5

Detailed description of the invention

Figure 1.A shows two bf3RDAQ data acquisition clients **101** and **102** of the present invention, and the system in which they operate. Both devices have access to a network **106**. The system further consists of a bf3RDAQ data acquisition server **103**, which connects to a database **105**. In Figure 1.A a bf3RDAQ data acquisition client **101** establishes a connection **107** through the network **106** to the bf3RDAQ data acquisition server **103**. Depending on the type of network, a Remote Access Server **104** may be needed (e.g. for modem/ISDN connections) as a router between the server and the clients.

Figure 1.B provides more detailed overview of the elements which constitute the bf3RDAQ remote data acquisition system **201** of the present invention. The system consists of the following building blocks:

1. The bf3RDAQ embedded software module **208**
2. The bf3Net Internet Communication software module **207**
3. The bf3RDAQ communication hardware module **206**
4. The bf3RDAQ server software module **202**
5. An operating system platform **203** (e.g. Microsoft Windows, UNIX)
6. An optional Remote Access Server **204**

20

The bf3RDAQ server software module **202** has access to a database **214**.

On the client side, to create a custom data acquisition application **213**, the application developer must design the application-specific data acquisition hardware **210** to retrieve data from the data source **212**. On the server side, the application developer must design a database application which interacts with database **214**.

25

The bf3RDAQ remote data acquisition system of the present invention can further be enhanced by adding the bf3Scp target software module **209** which interacts with a bf3Scp User-Interface application **211** through the bf3RDAQ communication hardware module **206**.

30

A block diagram of an embodiment of a modem bf3RDAQ data acquisition client communication hardware module, according to the present invention, is shown in Figure 1.C. All data and communication processing is performed by the digital signal processor **301**. The

digital signal processor has access to data memory **303** and program memory **302**, and is clocked by a clock device **304**. A real-time clock (RTC) **311** serves as time reference.

The communication channel of the modem bf3RDAQ data acquisition client communication hardware module, according to the present invention, consists of a telecommunications line interface (LIF) **308** together with a Direct Access Arrangement (DAA) **307**. The receive path further consists of a low-pass filter (LPF) **309** and an analog-to-digital (A-D) converter **310**. The transmit path further consists of a digital-to-analog (D-A) converter **305** and a low-pass filter (LPF) **306**. The line interface circuitry **308** is able to detect an incoming call, and the identifier of the calling party. Thus, the bf3RDAQ data acquisition client can selectively act as a receiver. The line interface circuitry **308** also detects if the telephone line is in use prior to establishing a connection or requested during an active connection by another party. Thus, the bf3RDAQ data acquisition client can be configured not to interfere with other equipment and to release the line in case of emergency conditions.

For serial communication, a Universal Asynchronous Receiver and Transmitter (UART) interface **313** is provided. To interface with the application-specific data acquisition hardware, a data acquisition interface **312** is provided.

An architecture block diagram of the bf3RDAQ data acquisition client software, according to the present invention, is shown in Figure 1.D. The central element of the architecture is the bf3RDAQ Application Programming Interface (API) software module **407**. It interfaces with an embedded database **408**, which acts as local storage of the data acquired by the client, and of configuration data which controls the operation of the data acquisition client.

The bf3RDAQ Application Programming Interface (API) software module **407** further interfaces with the bf3Net Internet Communication software module **402**, according to the present invention, through the following Internet application protocol modules:

1. Simple Mail Transfer Protocol (SMTP) client application module **403**,
2. Post Office Protocol Version 3 (POP3) client application module **404**,
3. HyperText Transfer Protocol (HTTP) server application module **405**,
4. File Transfer Protocol (FTP) client application module **406**.

The Simple Mail Transfer Protocol (SMTP) **403** is used to transfer the data acquired by the bf3RDAQ client, encapsulated in an electronic mail message, from the bf3RDAQ data acquisition client embedded database **408** to the bf3RDAQ central database, according to the present invention.

The Post Office Protocol Version 3 (POP3) **404** is used to transfer data (e.g. configuration data), encapsulated in an electronic mail message, from the bf3RDAQ central database to the bf3RDAQ data acquisition client embedded database **408**.

5 The HyperText Transfer Protocol (HTTP) server **405** is used to provide HTML configuration interfaces which can be accessed through a compliant web browser (e.g. Microsoft Internet Explorer).

The File Transfer Protocol (FTP) **406** is used to transfer new software versions from the bf3RDAQ Server, according to the present invention, to the bf3RDAQ data acquisition client. The new software version can then be stored in the program memory of the bf3RDAQ data acquisition client, according to the present invention.

10 The bf3Net Internet Communication software module **402** further interfaces with the physical layer communications driver (PHY) **401** which interacts with the communications hardware **409** (e.g. modem or ISDN interface).

The bf3RDAQ Application Programming Interface (API) software module **407** further provides programming interface functionality to facilitate the design of the custom data acquisition application software **410**.

An architecture block diagram of the bf3RDAQ data acquisition server software, according to the present invention, is shown in Figure 1.E. The central element of the architecture is the bf3RDAQ Server software module **505**. It interfaces with the central database **506**, which acts as the storage of the data acquired by all clients of the data acquisition application system, according to the present invention.

20 The bf3RDAQ Server software module **505** further interfaces with a standard SMTP- and POP3-compliant Internet Mail Server **504**, from which it retrieves the acquired data which is sent to the server by a bf3RDAQ data acquisition client, according to the present invention.

25 The Internet Mail Server **504** provides dedicated electronic mailboxes with associated electronic mail addresses for the reception of data messages from the bf3RDAQ data acquisition clients.

The Internet Mail Server **504** can also be used to send data from the central database **506** to a bf3RDAQ data acquisition client. For this purpose, each bf3RDAQ client in the bf3RDAQ data acquisition application system must have a POP3 mailbox at the Internet Mail Server **504**.

30 The Internet Mail Server makes use of the Transmission Control Protocol (TCP) **503**, the Internet Protocol (IP) **502**, and an Internet-compatible datalink **501** (e.g. Ethernet) for communication through the network, according to the present invention.

A custom database application **507** is the only component that needs to be provided by the application developer to complete the server-side of the bf3RDAQ-based data acquisition application, according to the present invention.

Figure 2.A shows the architecture of the bf3Net Embedded Internet Communication software, according to the present invention, as a conceptual network of multiplexers and demultiplexers (or mxDmx network, for short), controlled by a protocol engine (bf3Net Engine) **101**.

A node in the mxDmx network is either a multiplexer or a protocol module. Each multiplexer has a number of input ports. By making the number of ports statically configurable for each multiplexer, the topology of the mxDmx network can be customized for the application.

The bf3Net architecture, according to the present invention, is subdivided into a number of functional layers. These layers are defined as follows:

1. Layer 0: Datalink and Frame Encapsulation Layer
2. Layer 1: Internet Protocol Layer
3. Layer 2: Transport protocol and socket layer

It is important to stress that this layer structure is based on functional properties, not on communication layer assignments.

Layer 0 of the bf3Net architecture, according to the present invention, is only discussed in general terms in the context of Figure 2.A. Please refer to one of the description of Figures 2.C.and 2.D for the specific details of the datalink layer implementations. The datalink is conceptually depicted as a datalink multiplexer **104** with a number of datalink protocol modules (DL-Px) **105**, together with a frame encapsulation module **103**.

Layer 1 of the bf3Net architecture, according to the present invention, consists of the Internet Protocol multiplexer **105**, and the application protocol modules which reside at this layer, such as the Internet Control Message Protocol (ICMP) module **111**.

Layer 2 of the bf3Net architecture, according to the present invention, consists of the Universal Datagram Protocol (UDP) multiplexer **107**, and the Transmission Protocol (TCP) multiplexer **108**. Both multiplexers connect to the bf3Net Socket Interface module **109**, which is also part of Layer 2 of the bf3Net architecture.

The bf3Net socket interface module **109** acts as a cross-connect between the UDP and TCP multiplexers and the application protocol modules **110** (indicated as APP-Py in Figure 2.A). The bf3Net Socket Interface module **109** is part of the bf3Net Application Programming Interface **114**.

To each input of a multiplexer, either a protocol module or another multiplexer is connected. Each multiplexer port is identified by a number which is unique for a multiplexer. Which node is connected to which port can also be (statically) configured. The port identifiers at each layer are used to describe a path through the mxDmx network. Such a path descriptor
5 can be an 8-bit or 16-bit value with a field for each functional layer. The path descriptor format is shown in Figure 2.B. For example, the path **113** from the engine to TCP socket 1 is identified as 7-2-1 (or 0xF1) in an 8-bit configuration (3:2:3 bits).

Port 0 of every multiplexer in the mxDmx network of the bf3Net architecture (e.g. port 0 **112** of the IP multiplexer **106**), according to the present invention is reserved and serves as
10 a data sink for incoming data which must be discarded. The reason for this will be explained below.

The central element of the bf3Net architecture is the bf3Net Engine **101**. It performs the following tasks:

1. Management of the bf3Net communication session,
- 15 2. Management of the physical communication layer **102**,
3. Operation of the multiplexers and demultiplexers,
4. Management of the data buffers,
5. Timer management,
6. Collection of debug and profiling information.

20 The interface between the bf3Net Engine **101** and the mxDmx network is implemented by the datalink multiplexer **104**. The bf3Net Engine also interfaces with the Frame Encapsulation module **103** in a similar way.

The bf3Net Engine **101** can be seen as a Central Processing Unit (CPU) of the bf3Net software. As such, the bf3Net Engine **101** requires a clock signal to keep it running. This
25 clock signal must be offered externally as a timer tick or an operating system task. The bf3Net Engine **101** is able to (re)schedule itself in the latter case.

The nodes in the mxDmx network, according to the present invention, interact with the bf3Net Engine **101** by sending messages to the bf3Net Engine **101** through the mxDmx network. To identify the originator of the message, the path descriptor is used. The following
30 messages types are defined:

1. Data buffer request
2. Data buffer grant
3. Timer request
4. Timer expiration

5. Status messages
6. Event notifications
7. Error reports

The bf3Net Engine **101** processes the messages and responds accordingly. The
5 bf3Net engine **101** has two types of messages it can send upstream through the mxDmx
network: routed messages (using a path descriptor), or broadcast messages. Each node in
the network is required to pass broadcast messages to all connected upstream nodes, and to
route other messages to the appropriate node.

Data is passed through the mxDmx network by means of data buffers (not depicted in
10 Figure 2.A), which are identified by a unique number. These buffers are managed by the
bf3Net Engine **101**. Before a buffer can be used, a node needs to request access by sending
the corresponding message to the bf3Net Engine **101**. The same applies for the use of
timers.

Access to a data buffer is granted on priority and age (first come, first serve). The
15 responses to the nodes are also routed through the mxDmx network based on path
descriptors. When a node no longer requires access to a buffer, it must release the buffer;
again, this is done by sending a message to the bf3Net engine **101** through the mxDmx
network.

When data is received from the physical layer **102**, the bf3Net Engine **101** is notified
20 through the bf3Net Physical Layer Interface (PLI) **113**. The bf3Net Engine notifies the Frame
Encapsulation module **103**, which retrieves the data from the physical layer, and stores it in a
data buffer (which was requested from and granted by the bf3Net Engine **101**).

Once a complete frame has been received, bf3Net Engine **101** is notified by the
Frame Encapsulation module **103**, and the following three-step procedure is invoked:

- 25 1. The bf3Net Engine forwards the data buffer to mxDmx network to setup the path
descriptor.
2. The path identifier is masked depending on the state of the communication session.
3. The data buffer is processed, based on the (masked) path identifier.

The first step is based solely on the parameters in the received frame (datalink, IP,
30 and TCP/UDP protocol identifier). Since a protocol is mapped to a port, a demultiplexer needs
to do nothing more than fill the appropriate field of the path descriptor and pass the buffer to
an upstream multiplexer if applicable, or terminate if the path leads to a protocol module at its
layer. If a protocol is not supported or recognized, a value of '0' should be entered. During this

step, the data integrity verification is also done (e.g. IP checksum). If this verification fails, the path is also set to '0'.

The second step is done by the bf3Net Engine **101** to mask the upstream path in case a path is not available (e.g. to avoid processing of an incoming TCP segment when the datalink has not yet been established). All unsupported path fields are set to '0'.

The third step is the actual data processing. Because the 'zero port' is reserved as universal sink for data which must be discarded, all erratic data buffers are led to this port, which simply releases the data buffer. If the data is correct in the general sense, it is led to appropriate protocol module, based on the established path descriptor.

This procedure (in combination with the zero ports) is the key to simplifying the design of the multiplexers, as they need to have no knowledge of other protocol layers (apart from the routing information) whatsoever. Also, by choosing this design approach, a protocol module can easily be exchanged, because the demultiplexing and protocol functions are isolated from each other. Another powerful feature of this architecture is the fact that the mxDmx network is used for both the control and data communication. The design of the protocol nodes can all be based on a common design framework.

When data must be transmitted, the applicable protocol node must fill its part of the requested data buffer (once access is granted), and pass it to the downstream multiplexer node. Please note that this statement implies two things: (a) a multiplexer will never request a data buffer, (b) a protocol node will never pass a buffer to another protocol node. This again simplifies the design of the mxDmx network nodes. Before a node passes a data buffer downstream, it must set the downstream port number in the path descriptor for the buffer. All downstream multiplexers will add their protocol information (e.g. IP header), using the path descriptor. When a completed buffer has been sent by the physical layer, the originating node will be notified.

If a physical layer communication channel needs to be opened (e.g. a modem connection), the bf3Net socket interface module **109** will directly signal the bf3Net Engine **101** to do so. A channel identifier can be passed with this request. The bf3Net Engine **101** will instruct the physical layer to start opening the connection, and notify the mxDmx network once the physical layer indicates it is ready. The bf3Net Engine **101** will then coordinate establishment of the datalink, and manage it afterwards, based on the event notifications it receives from the mxDmx network nodes.

The bf3Net Engine **101** can individually or collectively enable and disable multiplexers with the 'enable signals' shown in Figure 2.A. Each multiplexer in the mxDmx network has an

MUX_ENABLE input for this purpose. This way, if needed, the bf3Net Engine **101** can selectively stop data processing (e.g. in case the communication link is lost).

Finally, the bf3Net Engine **101** collects and maintains information, which can be used for profiling and debugging (e.g. buffer usage and error history). This information can be retrieved from the bf3Net Engine **101** with API commands. Also, parameters can be changed through the API, allowing run-time profiling.

Figure 2.B shows the layout of the bf3Net mxDmx network path descriptor, according to the present invention. The functional description of this path descriptor has already been given in the discussion of Figure 2.A. The path descriptor consists of three bitfields (one for each layer of the bf3Net architecture), each with a variable length. Together the lengths of the bitfields for each layer must equal 8 or 16 bits.

Figure 2.C shows the datalink architecture for Point-to-Point Protocol (PPP) connections in the bf3Net architecture, according to the present invention. The Frame Encapsulation functionality is implemented by the High Level Datalink Control module **302**. The datalink multiplexer is implemented by the Point-to-Point Protocol (PPP) multiplexer **301**.

A number of protocol modules can reside at this layer of the bf3Net architecture, according to the present invention, such as: Link Control Protocol (LCP), No authentication (AUTH), Password Authentication Protocol, Challenge Handshake Authentication Protocol (CHAP), Microsoft CHAP (MS-CHAP), and the Internet Protocol Control Protocol (IPCP).

Figure 2.D shows the datalink architecture Ethernet connections in the bf3Net architecture, according to the present invention. The Frame Encapsulation functionality is implemented by the Ethernet Encapsulation module **402**. The datalink multiplexer is implemented by the Ethernet multiplexer **401**.

A number of protocol modules can reside at this layer of the bf3Net architecture, according to the present invention, such as: Address Resolution Protocol (ARP) **403**, and Reverse Address Resolution Protocol (RARP) **404**.

Figure 3.A shows the general architecture of a bf3Scp Serial Communication Protocol session, according to the present invention. In the bf3Scp terminology, both sides of the communication session are referred to as implementations. A communication session consists of the exchange of messages and replies, according to a handshake definition.

The host implementation **101** consists of a graphical user-interface (GUI) program **103** that has access to a target database **104**, and communicates with the target implementation through the built-in COM port **105** of the Personal Computer on which it runs.

The bf3Scp target implementation **102** consists of the target software **108** which communicates with the host implementation through the serial port **107** of the target processor on which it runs.

5 The RS232-to-TTL signal level conversion **106** is not regarded as part of either implementation, although because of to the bf3Scp signal definitions it must be provided. A cable which has been defined for this purpose will be described in the discussion of Figure 3.F.

10 The target database **104** is provided to minimize the number of communication parameters that need to be configured to establish a communication session. It contains the parameters which are fixed at design-time. These parameters may also be stored in the GUI application, if this is more advantageous.

An overview of a user-interface application based on the bf3Scp architecture, according to the present invention, is shown in Figure 3.B.

15 Enclosed by the dashed line are the elements of which the bf3Scp invention **201** consists:

1. bf3Scp host protocol engine **202**,
2. bf3Scp target serial port driver **203**,
3. bf3Scp target protocol engine **204**.

20 The bf3Scp host protocol engine **202** is an ActiveX object which handles all the protocol-related serial communication through the RS-232 COM port **205**. It runs on any Microsoft Windows-compatible platform, and is independent of the host user-interface implementation **209**. It comes in two versions: a local server which must run on the same host PC as the user-interface, or a remote server which can interact with the user-interface through a network, making use of Microsoft's DCOM technology.

25 The bf3Scp target serial port driver **203** handles physical layer communication through the Target serial port **207** on the target side. It must be developed for every processor that makes use of bf3Scp. For communication between the PC COM port **205** and the Target Serial Port **207**, the RS-232-to-TTL level conversion **206** is required.

30 The bf3Scp target engine **204** is processor-independent; it handles all protocol-related communication on the target side which is not covered by the engine. It passes the received messages to the Custom Target application software **208** which must take appropriate action. With bf3Scp, the development of a custom user-interface for embedded target is limited to the following steps:

1. Development of the Custom User-Interface software **209**,

2. Definition of the target-specific message and reply codes,
3. Sending messages to the target from the user-interface to the target through the bf3Scp host engine **202**,
4. Processing received messages on the target side by the Custom Target Application software **208**.
5. Sending a standard or custom reply
6. Processing the received reply in the Custom User-Interface software **209**.

This makes developing user-interfaces a straight-forward task. An application can optionally make use of the target database **210** (discussed in the context of Figure 3.A).

Figure 3.C shows the format **301** of the bf3Scp message, according to the present invention. The bf3Scp message consists of the following fields:

1. Fixed header (value 0xBF) **302**
2. 4-bit sequence field SEQ **303**
3. 4-bit flags field FLAGS **304**
4. 1-bit sync field S **305**
5. 7-bit length field LENGTH **306**
6. 8-bit message type field MESSAGE **307**
7. Byte-multiple payload **308**
8. 8-bit frame checksum field FCS **309**
9. Fixed trailer (value 0x03) **310**

The fixed header **302**, in combination with the LENGTH field **306**, the FCS field **309**, and the fixed trailer **310** make it simple for (embedded) applications to detect the end of a frame: if the accumulated sum of all received bytes equals '0', the last received byte is equal to 0x03, and the number of bytes received equals the value in the LENGTH field, the frame has been completely and correctly received.

The MESSAGE field **307** contains the qualification of the payload **308**. Odd-numbered values represent messages, even-numbered values are reserved for replies. This also simplifies processing of incoming frames.

The SEQ field **303** is used to detect duplicate or out-of-order reception of messages and replies. Its value is incremented with each message sent (modulo-16) for a certain direction (target-host or host-target).

The FLAGS field **304** has a fixed value of 0x05. It is reserved for future applications.

The sync field S **305** is used for synchronization of the datalink. When its value is '1', the bf3Scp message is used for this purpose.

Figure 3.D shows the synchronization procedure for a bf3Scp communication session, according to the present invention. The datalink is only (re)synchronized by the host implementation, thus simplifying the design of the target implementation.

5 A synchronization procedure starts by the sending of a SYNCREQ message **401** by the host to the target. The S field is set when this message is sent. The target must respond by sending a SYNCACK reply **402** (again with the S bit set) to the host. The host will acknowledge the reception of the SYNCACK reply **402**, by sending an ACKNOWLEDGE **403** message (once more with the S bit set) to the target. This completes the synchronization procedure.

10 Figure 3.E shows the handshake procedure for the exchange of messages and replies in a bf3Scp communication session, according to the present invention. Each implementation can send messages. The receiving implementation must always respond to the reception of a message according to the described handshake procedure.

A message transfer starts by the sending of a message **501** by implementation A to the implementation B. The S field is cleared when a normal message is sent. Implementation B must respond by sending a reply **502** (also with the S bit cleared) to implementation A, which will acknowledge the reception of the reply **502**, by sending an ACKNOWLEDGE **503** message (once more with the S bit cleared) to the target. This completes the message transfer

20 Figure 3.F shows schematically the general mechanical design of a cable with integrated RS232-to-TTL level conversion.

The design consists of a 9-pin or 25-pin SUB-D type female connector **601**, which plugs directly into the serial COM ports of personal computers. The connector is mounted on a printed circuit board (PCB) **606**, which is small enough to fit into the enclosure of the connector **601**.

25 The PCB **606** accomodates an integrated circuit **605** which provides the RS232-to-TTL level conversion, and a board-to-cable connector **604**, which connects to a cable (e.g. a flatcable) **603**. On the other end of the cable **603**, a cable socket connector is mounted.

Claims

1. A method for transferring generic data acquired at a remote location to a central database based on e-mail communication, comprising the steps of:
 - 5 a. encapsulating the acquired data in an electronic mail message; and
 - b. sending the electronic mail through a network (public or private) to a central database server; and
 - c. extracting the data from the electronic mail message by the central database server; and
 - 10 d. storing the extracted data in the central database,whereby said acquired data is communicated directly to said database server by providing an architecture for Internet communication software for embedded platforms, said architecture being based on a network of software multiplexers and demultiplexers, controlled by an integrated protocol engine.
- 15 2. An apparatus which is able to perform steps a and b presented in the previous claim 1.
3. A definition for a server application, which is able to perform steps c and d presented in the previous claim 1.
4. A format of an electronic mail message for encapsulation of the acquired data
- 20 according to claim 1 as plain text.
5. A format of an electronic mail message for encapsulation of the acquired data according to claim 1 as an attached file.
6. An architecture for Internet communication software for embedded platforms based on a network of software multiplexers and demultiplexers, controlled by an integrated
- 25 protocol engine.
7. An architecture for message-based serial communication for creation of configuration interfaces, based on a host and target protocol engine.
8. A format for a message datagram according to the previous claim 7.
9. A communication protocol, comprising physical layer and datalink layer specifications
- 30 for the exchange of message datagrams according to the previous claim 7.
10. A target identification method based on the combination of the following parameters:
 - a. 32-bit vendor identifier
 - b. 32-bit application identifier
 - c. 32-bit unit identifier

11. Storage of parameters a and/or b of the previous claim 10 in a database for the assignment of a set of messages according to the previous claim 7, to an application identifier of the previous claim 10b.
- 5 12. Configuration and management of the apparatus of claim 2 by sending an electronic mail message containing configuration data and management instructions to the mailbox of said apparatus, and POP3-compliant retrieval and evaluation of this message by the apparatus from the server.
- 10 13. Configuration and management from a remote device of the apparatus presented in the previous claim 2 through an HTML-based configuration interface accessible by establishing a communication session and interaction with the HTML file through the network to which both connect with the embedded HTTP server hosted by the apparatus.
- 15 14. Updating of the software version of the apparatus presented in the previous claim 2 by downloading a software image from the server application presented in claim 3 through the network to which both connect by means of the FTP or HTTP protocol.
- 15 15. Integration of an RS232-to-TTL conversion circuit in the connector housing of a communication cable.

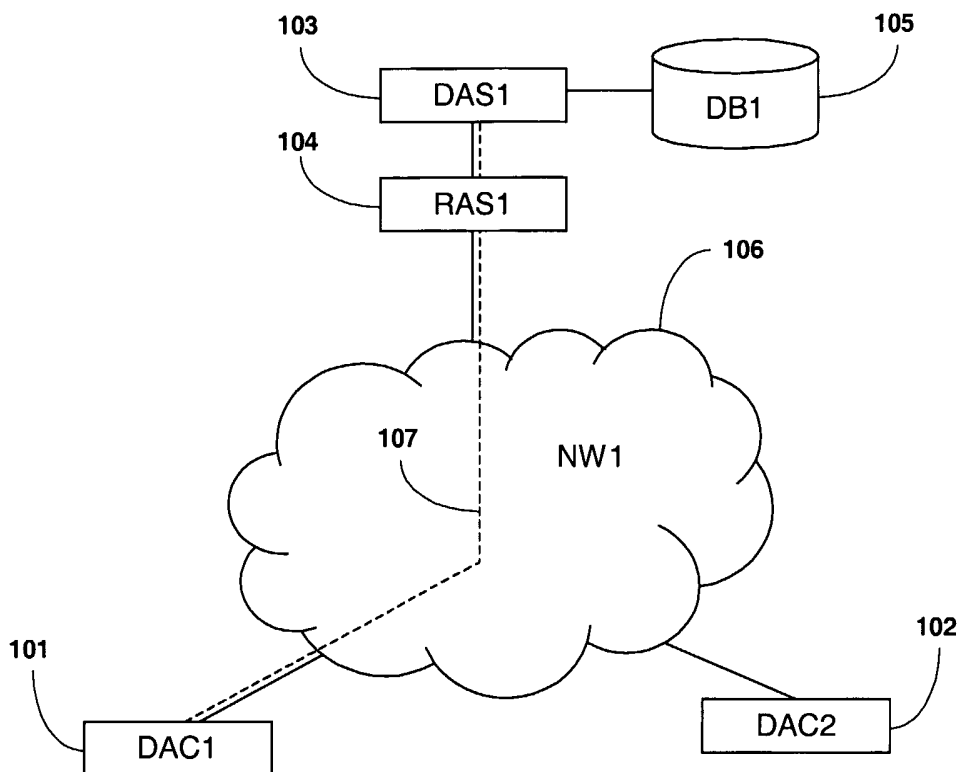

Figure 1.A

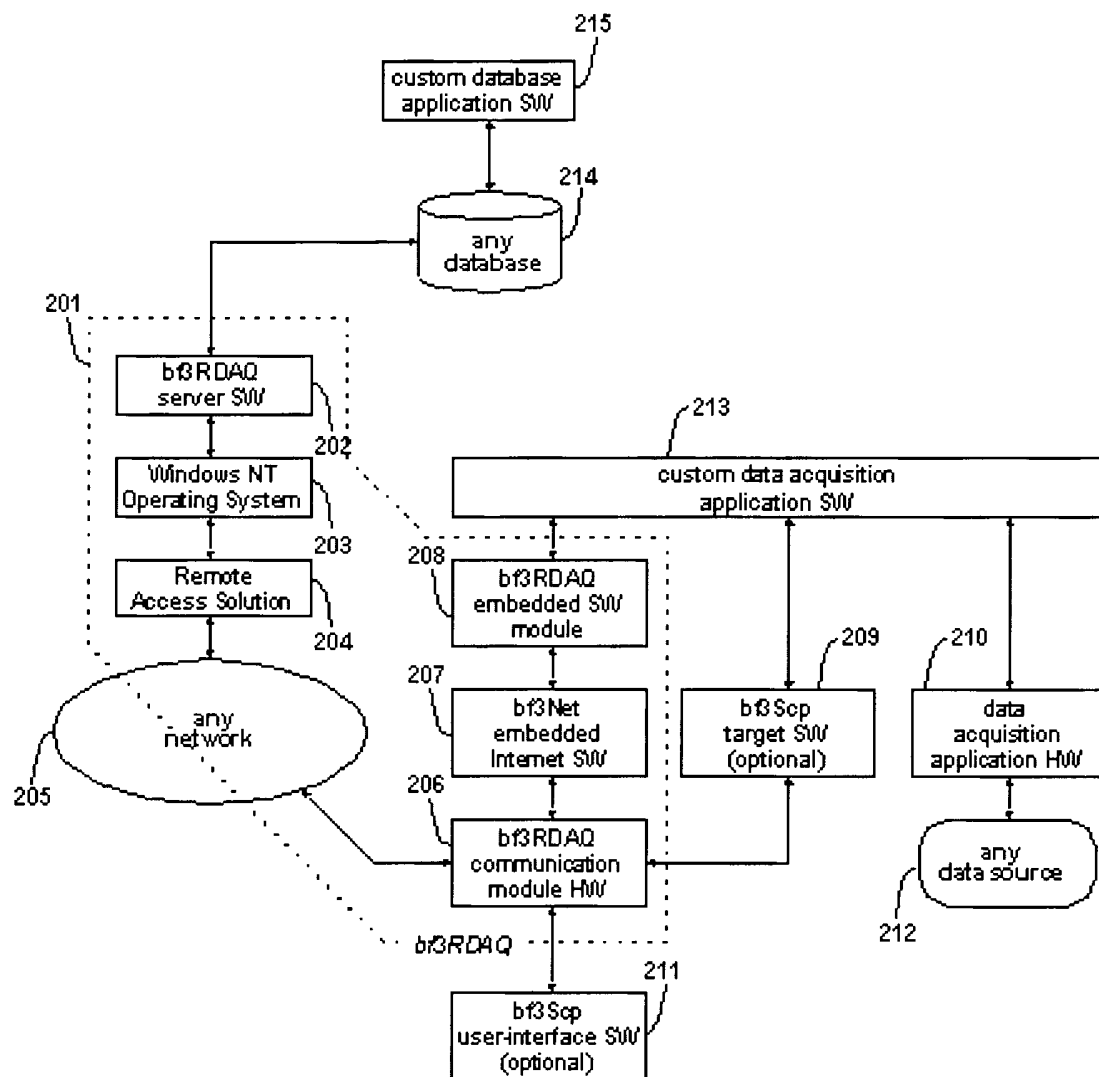

Figure 1.B

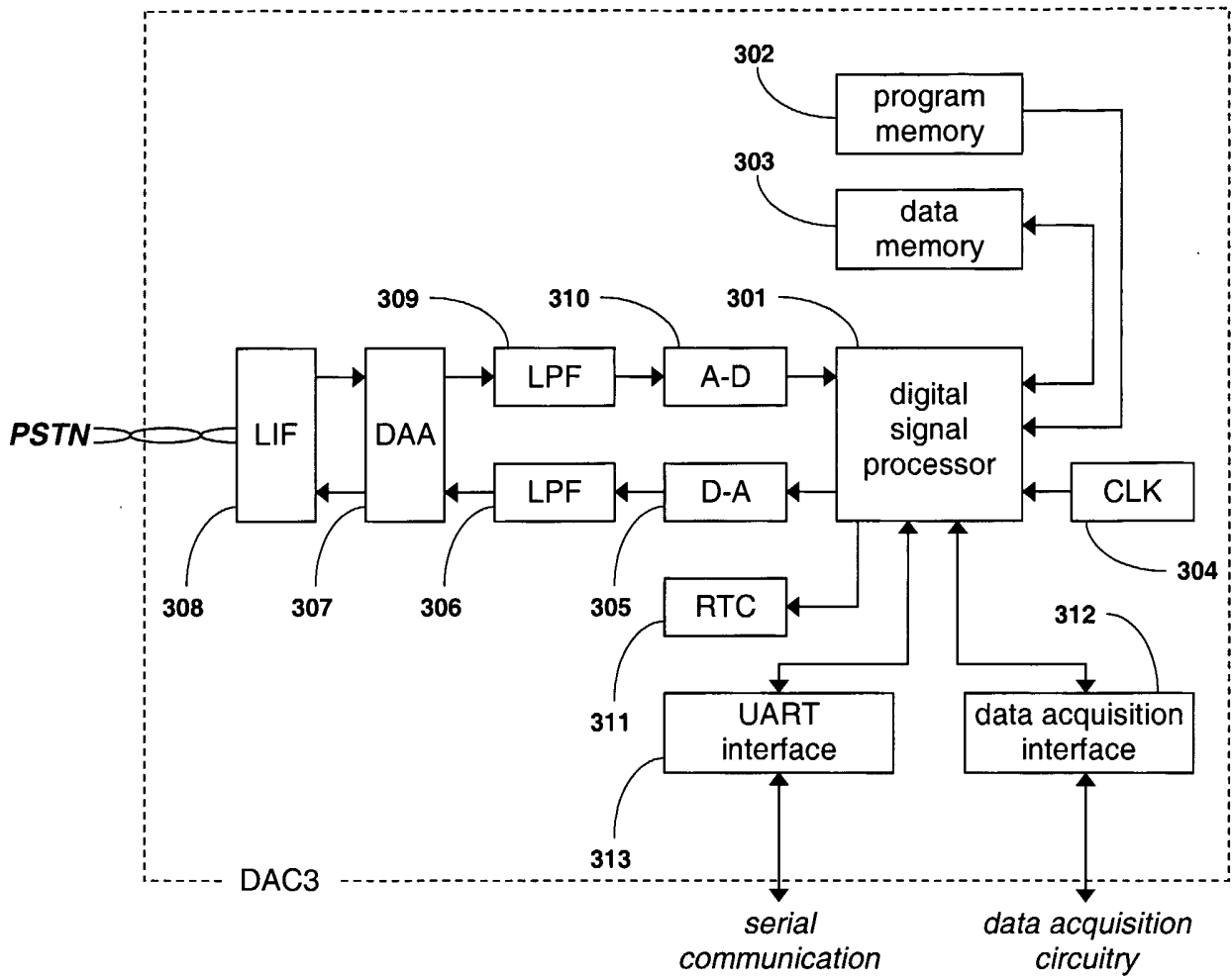

Figure 1.C

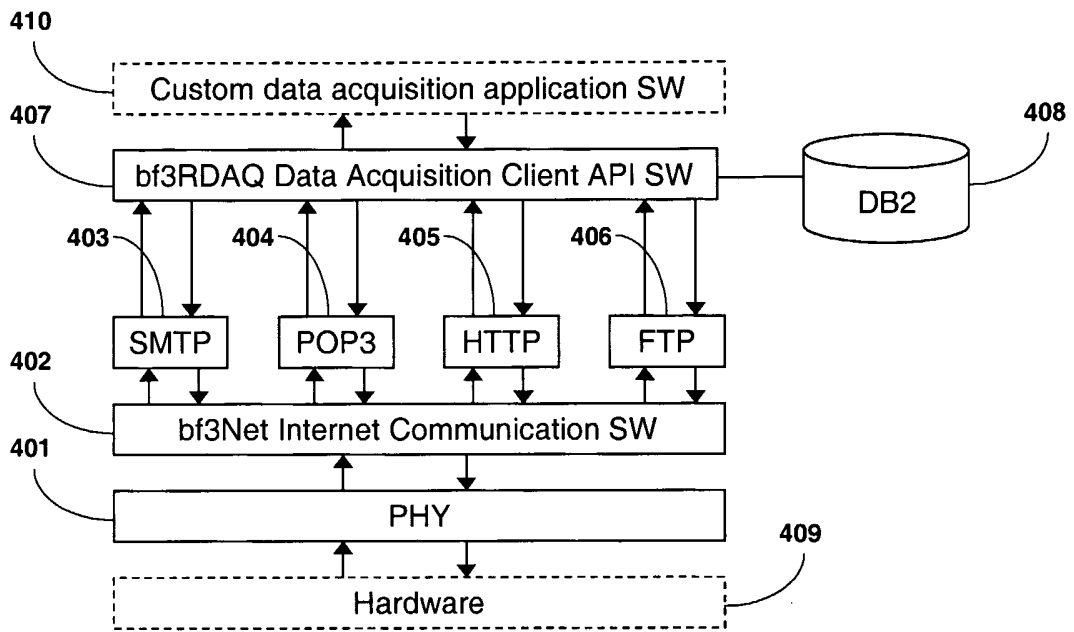

Figure 1.D

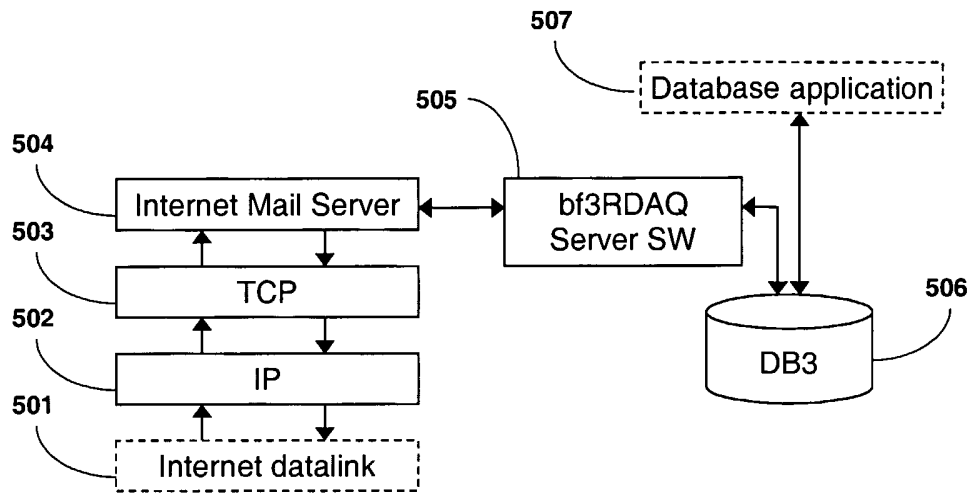

Figure 1.E

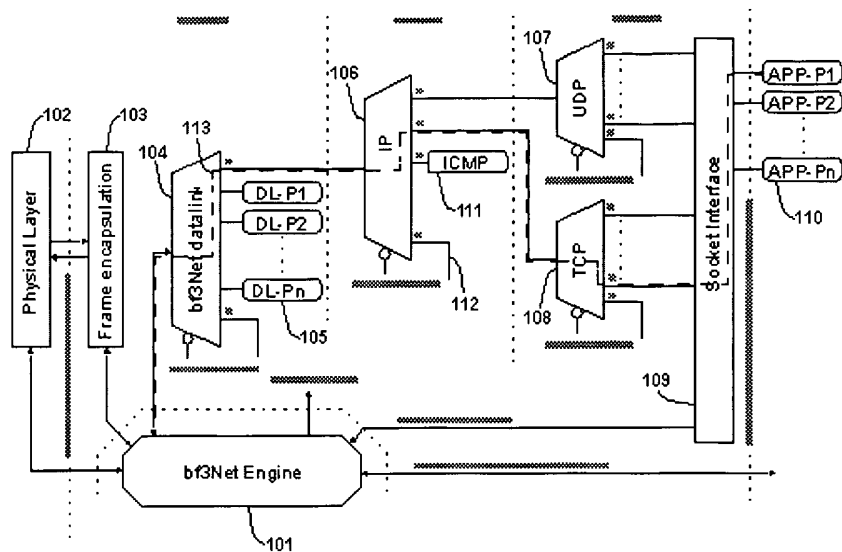

Figure 2.A

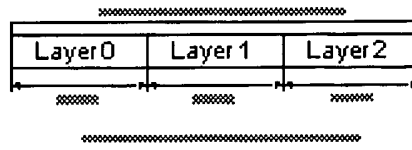

Figure 2.B

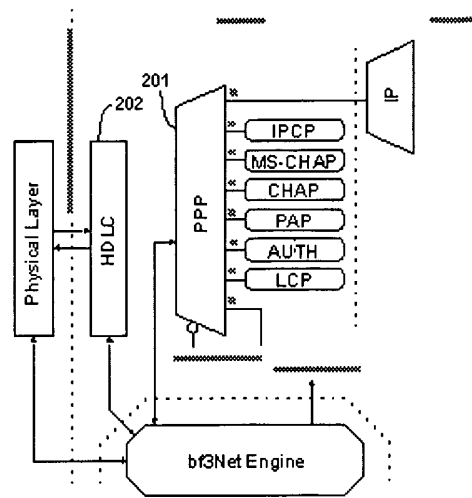

Figure 2.C

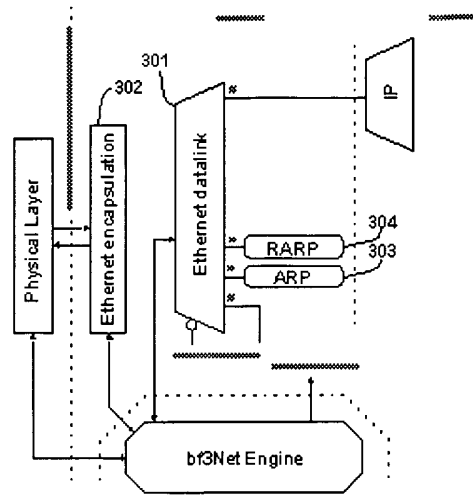

Figure 2.D

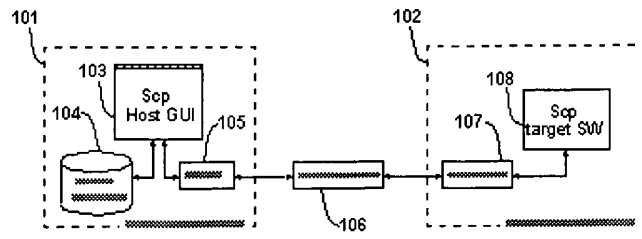

Figure 3.A

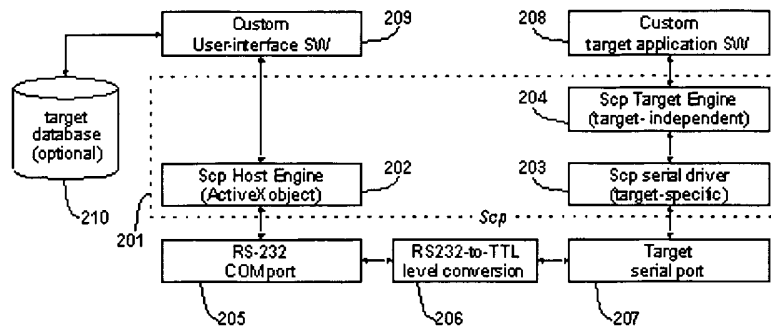

Figure 3.B

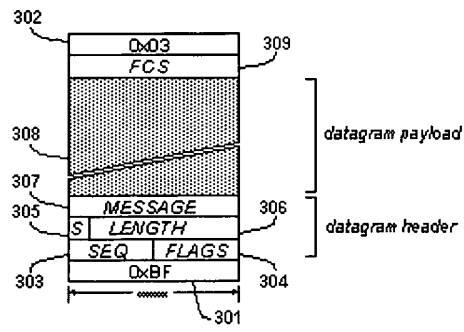

Figure 3.C

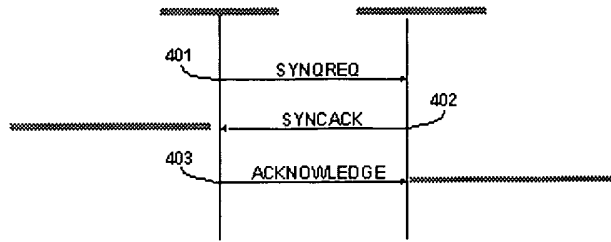

Figure 3.D

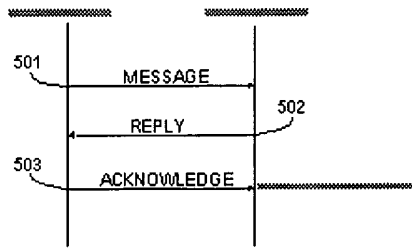

Figure 3.E

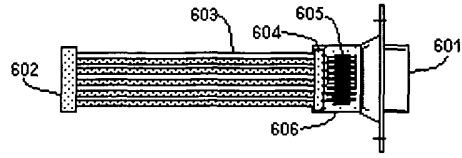

Figure 3.F