



US 20140338416A1

(19) **United States**

(12) **Patent Application Publication**
Song

(10) **Pub. No.: US 2014/0338416 A1**

(43) **Pub. Date: Nov. 20, 2014**

(54) **FOLDING SYSTEM FOR A CUTTING BLADE**

Publication Classification

(71) Applicant: **Seoul Laser Dieboard System Co., Ltd.**, Anyang City (KR)

(51) **Int. Cl.**
B21D 5/16 (2006.01)
B21D 7/022 (2006.01)
B21D 37/20 (2006.01)

(72) Inventor: **Byung-Jun Song**, Anyang City (KR)

(52) **U.S. Cl.**
CPC **B21D 5/16** (2013.01); **B21D 37/205** (2013.01); **B21D 7/022** (2013.01)

(73) Assignee: **Seoul Laser Dieboard System Co., Ltd.**, Anyang City (KR)

USPC **72/387**

(21) Appl. No.: **14/252,324**

(22) Filed: **Apr. 14, 2014**

(57) **ABSTRACT**

Related U.S. Application Data

(63) Continuation of application No. 13/679,917, filed on Nov. 16, 2012, which is a continuation of application No. 11/558,316, filed on Nov. 9, 2006, now Pat. No. 8,327,679, which is a continuation of application No. 10/445,467, filed on May 27, 2003, now abandoned, which is a continuation of application No. 09/575,095, filed on May 19, 2000, now Pat. No. 6,405,574, which is a continuation of application No. 09/247,408, filed on Feb. 10, 1999, now Pat. No. 6,128,940, which is a continuation of application No. 09/049,391, filed on Mar. 27, 1998, now Pat. No. 5,870,919, which is a continuation of application No. 08/668,379, filed on Jun. 21, 1996, now Pat. No. 5,787,750.

Foreign Application Priority Data

Jun. 22, 1995 (KR) 1995-16975

A bending apparatus including: a transferring unit for transferring a metallic rule through a passage formed by a guide, said passage defining a longitudinal axis; a folding unit having first and second rotary bodies spaced to receive said metallic rule therebetween; and a pair of bending fingers including a first bending finger and a second bending finger, said pair of bending fingers supported to revolve and move in a direction substantially transverse to the longitudinal axis for applying force against the metallic rule passing through the guide, said pair of bending fingers positioned adjacent to the guide, and for bending the metallic rule to desired angles, wherein each finger of said pair of bending fingers is each configured for arcuate rotational motion relative to said guide from a first position toward at least one second position to bend a portion of said metallic rule, and wherein said pair of bending fingers rotate about a single rotational axis relative to said guide.

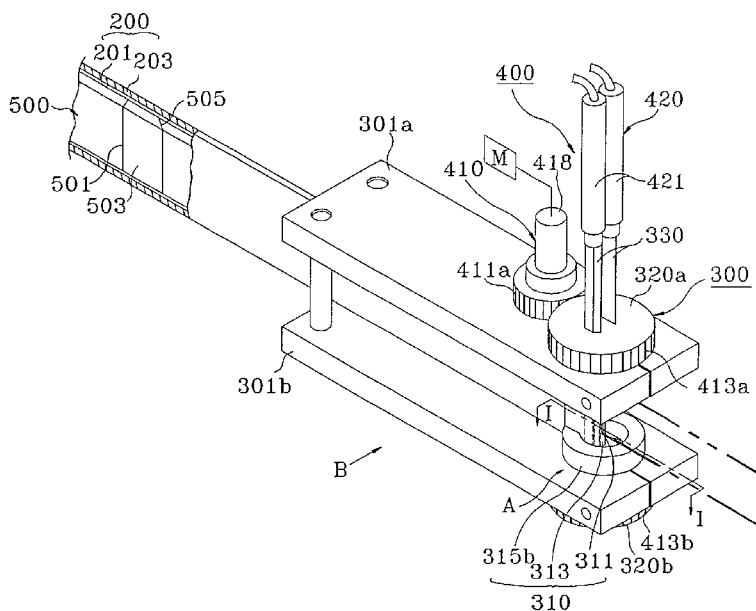

FIG. 1

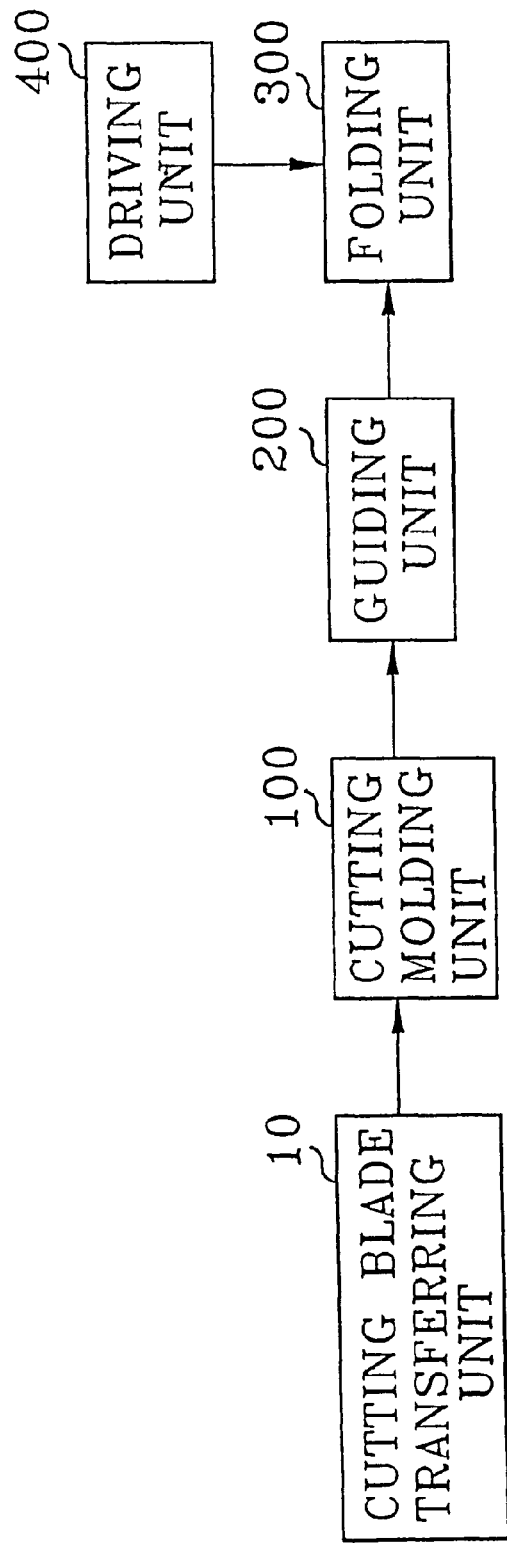

FIG. 2

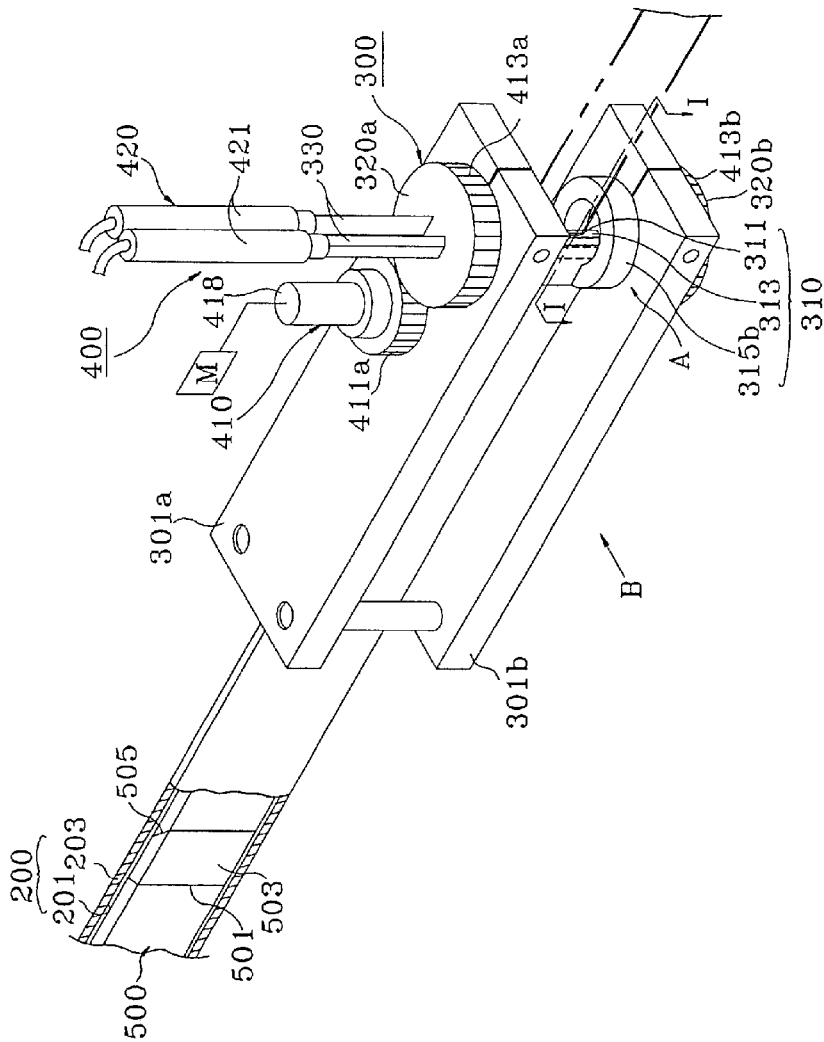

FIG. 3

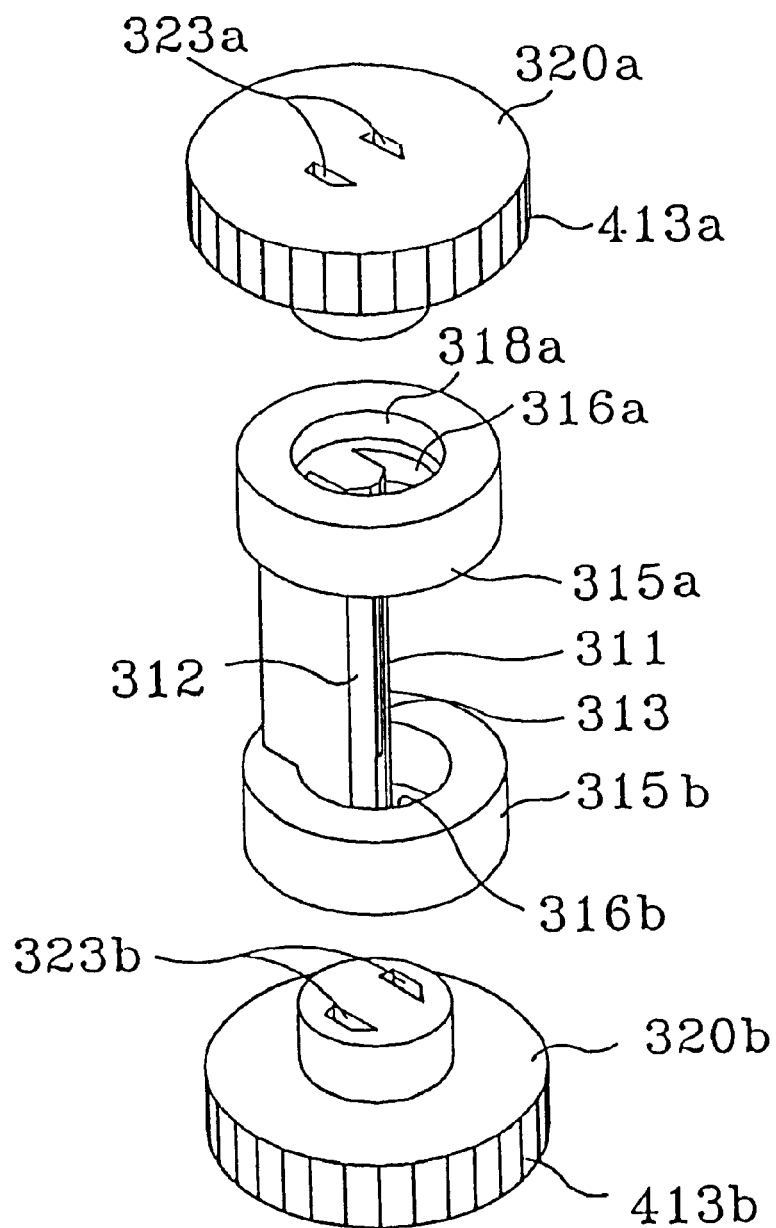

FIG. 4

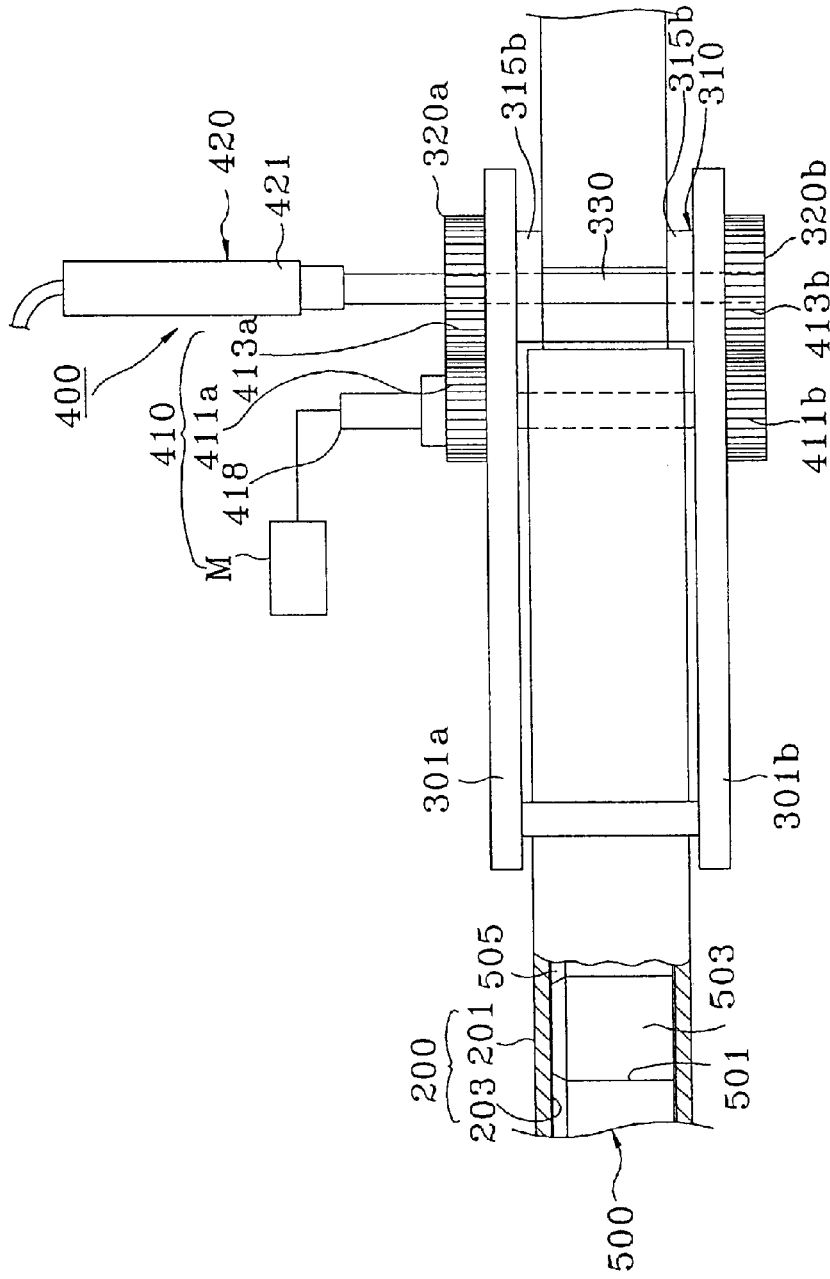

FIG. 6

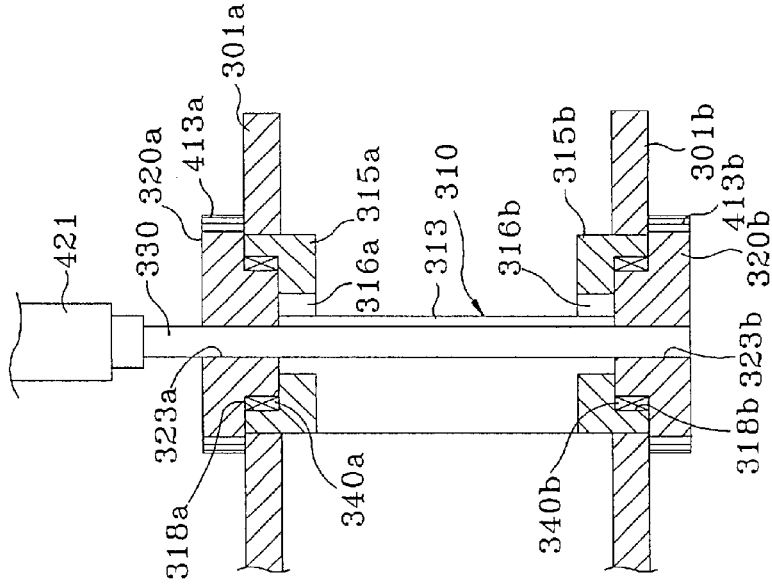
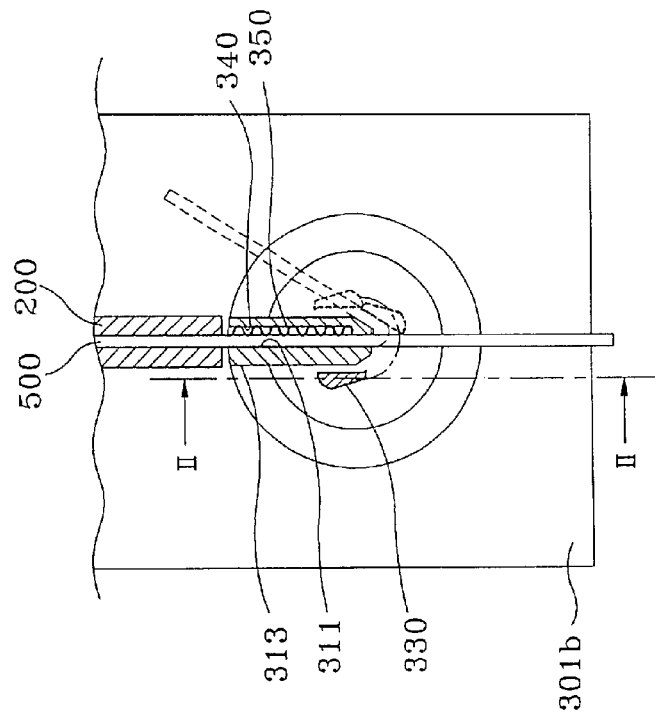

FIG. 5



FOLDING SYSTEM FOR A CUTTING BLADE

CROSS-REFERENCE TO RELATED APPLICATIONS

[0001] This application is a continuation application of co-pending U.S. patent application Ser. No. 13/679,917 filed on Nov. 16, 2012, which is a continuation of U.S. patent application Ser. No. 11/558,316 filed on Nov. 9, 2006 now U.S. Pat. No. 8,327,679, which is a continuation of U.S. application Ser. No. 10/445,467 filed on May 27, 2003 (now abandoned), which is a continuation of Ser. No. 09/575,095 filed on May 19, 2000 now U.S. Pat. No. 6,405,574, which is a continuation of U.S. application Ser. No. 09/247,408 filed on Feb. 10, 1999 now U.S. Pat. No., 6,128,940, which is a continuation of U.S. application Ser. No. 09/049,391 filed on Mar. 27, 1998 now U.S. Pat. No., 5,870,919, which is a continuation of U.S. application Ser. No. 08,668,379 filed on Jun. 21, 1996 now U.S. Pat. No.: 5,787,750, which claimed priority benefit to Korean Application No. 1995-16975, filed 22 Jun. 1995.

BACKGROUND

[0002] 1. Field of the Invention

[0003] The present invention relates to a folding system of a cutting blade used in forming a folding line on a sheet matter so that the sheet matter, such as paper or plastic, etc., may be made into a predetermined shape, and more particularly to a folding system of the cutting blade being used so that cutting and folding functions associated with the cutting blade can be performed in one process.

[0004] 2. Description of the Related Art

[0005] Generally, the cutting blade is attached to a pattern for use in pressing a folding or a cutting line on plate matters such as paper, canvas, leather, plastic, etc. The plate matters with such pressed lines can be used in a folded shape like a box. Accordingly, in order to assemble and process the plate matter into a predetermined box shape with the cutting blade, it is necessary that the cutting blade is folded in a shape suitable to forming the processing line in the box shape.

[0006] Conventional art for the folding device of a cutting blade is disclosed, for example, in Japan Patent No. 1988-309328 and No. 1990-20619. In the conventional art, however, a folded member used as a cutting blade is constructed by a rotary body that converts only a straight line movement into an orthogonal direction against the folded member on an end part of the folded member, or performs only a revolving movement centered about one point. Therefore, a disadvantage along with the use of the prior art cutting blade assemblies is that the folded angle of a processed member is limited to a single range of motion. Also, since two discrete functions are required, namely after a cutting work in separated places, then moving it into a folding device individually, and then the folding work is performed, or after the folding work, then moving it into a cutting device one by one, and then the cutting work is performed, additional time and labor are required, and the overall efficiency of the process decreases.

SUMMARY

[0007] Therefore, to address the above problem, embodiments of the present invention provide apparatus, method, and system for folding a cutting blade to improve work efficiency and productivity by continuously performing all work

elements needed in the cutting and folding works of the cutting blade provided in a sheet matter molding.

[0008] In one embodiment, a bending apparatus is disclosed. The bending apparatus includes: a transferring unit for transferring a metallic rule through a passage formed by a guide, the passage defining a longitudinal axis; a folding unit having first and second rotary bodies spaced to receive the metallic rule therebetween; and a pair of bending fingers including a first bending finger and a second bending finger, the pair of bending fingers supported to revolve and move in a direction substantially transverse to the longitudinal axis for applying force against the metallic rule passing through the guide, the pair of bending fingers positioned adjacent to the guide, and for bending the metallic rule to desired angles, wherein each finger of the pair of bending fingers is each configured for arcuate rotational motion relative to the guide from a first position toward at least one second position to bend a portion of the metallic rule, and wherein the pair of bending fingers rotate about a single rotational axis relative to the guide.

BRIEF DESCRIPTION OF THE DRAWINGS

[0009] The preferred embodiments are described with reference to the drawings wherein:

[0010] FIG. 1 is a block diagram for a folding system of a cutting blade according to the present invention;

[0011] FIG. 2 is a detailed perspective view showing a guiding unit and a folding unit of the cutting blade shown in FIG. 1;

[0012] FIG. 3 is a separated perspective view showing a unit "A" separated from FIG. 2;

[0013] FIG. 4 is a side view shown from a direction "B" of an arrow marking of FIG. 2;

[0014] FIG. 5 is a cross-sectional view taken along a line I-I of FIG. 2; and

[0015] FIG. 6 is a longitudinal sectional view taken along a line II-II of FIG. 5.

DETAILED DESCRIPTION

[0016] A preferred embodiment of the present invention will be described below in more detail with reference to the accompanying drawings.

[0017] FIG. 1 shows a block diagram of a folding system according to the present invention. In FIG. 1, the folding system of the cutting blade comprises a transferring unit **10** for transferring the cutting blade of a roll shape, a cutting molding unit **100** for cutting and processing the transferred cutting blade in a length suitable to a sheet material molding (not shown), a guiding unit **200**, positioned between the cutting molding unit **100** and a folding unit **300** for the cutting blade so as to be connected mutually, for stably guiding the cutting blade which is passed through cutting molding unit **100** to folding unit **300**, the folding unit **300** positioned adjacent to the guiding unit **200**, for folding the cutting blade transferred through the guiding unit **200** with a predetermined angle, and a driving unit **400** for driving the folding unit **300**, and thus a process work of the cutting blade provided to a sheet material molding is performed in succession. The detailed construction and operation of the above embodiment are explained below. The above cutting molding unit **100** is applied from Korean Patent No. 80607 entitled "Multi-purpose Cutter of a Cutting Blade for Die Cutter" filed by the present applicant on Dec. 11, 1991 and incorporated by ref-

erence herein. A detailed explanation for the cutting molding unit is therefore omitted below.

[0018] FIG. 2 is a detailed perspective view showing only a portion of the guiding unit associated with the cutting blade and the folding unit, shown schematically in FIG. 1. FIG. 3 is an exploded perspective view showing only a unit "A" separated from FIG. 2. FIG. 4 is a side view shown from a direction "B" of an arrow marking of FIG. 2. The guiding unit 200 is constructed by a guide nozzle 201 of a hollow structure configured and dimensioned to stably transfer a cutting blade 500 passed through the cutting molding unit to the folding unit 300.

[0019] Referring now to FIG. 2, guide nozzle 201 has a guiding passage 203 of a size such that cutting blade 500 can pass through freely, and two openings situated near the cutting molding unit 100 and the folding unit 300, respectively. The guide nozzle 201 is configured so that the cutting blade 500 may be moved together with a cutting tip 503 of a cutting portion 501.

[0020] Referring now to FIG. 3, folding unit 300 includes a fixing body 310 connected to folding and rotary bodies 320a and 320b for the folding, which are set on substantially rectangular shaped supporting frames 301a and 301b. The supporting frames 301a and 301b are situated spaced apart with an interval therebetween wherein the guide nozzle 201 can be situated. The fixing body 310 for the folding function is constructed by a folding body 313 having a guiding entrance 311 of a size through which the cutting blade 500 can be passed, and by annular support portions 315a and 315b formed on both ends of the folding body 313. The guiding entrance 311 of the folding body 313 is connected with the guiding passage 203 of the guide nozzle 201 such that the cutting blade 500 may enter inside the guiding entrance 311 freely. An end side portion of the guiding entrance 311 is preferably a slant side 312 to enhance the folding of the cutting blade 500.

[0021] The annular support portions 315a and 315b are provided to fixedly attach the folding body 313 to supporting frames 301a and 301b. As described later in FIG. 6 in detail, the annular support portions 315a and 315b include guiding slots 316a and 316b of a round shape, and round housing units 318a and 318b for housing rotary bodies 320a and 320b which may be rotated to facilitate the folding function. The rotary bodies 320a and 320b are configured to be rotatably housed within the round housing units 318a and 318b arranged on both sides of the fixing body 310. For a smooth revolving operation of the rotary bodies 320a and 320b, it is preferable to set bearings 340a and 340b on the inside circumference portion of the housing units 318a and 318b, as shown in FIG. 6. The rotary bodies 320a and 320b have guide holes 323a and 323b pierced therein and are configured to contact with the guide slots 316a and 316b.

[0022] The guide holes 323a and 323b are provided to insertably receive a folding member 330 to facilitate movement thereof, and are configured and dimensioned corresponding to a cross-sectional shape of the folding member 330. Although an example of the guide holes 323a and 323b is shown in the figures wherein each guide hole has a folding member set therein, it is preferable that only one folding member is set at a given time during operation. Referring now to FIG. 6, the folding member 330 is dimensioned to connect the rotary bodies 320a and 320b to each other while being positioned on the outer sides of supporting frames 301a and 301b. Accordingly, the folding member 330 is inserted

through guide hole 323a of rotary body 320a, passes through a lateral side of the fixing body 310, and is inserted into guide hole 323b inside of rotary body 320b and is capable of being moved upwards and downwards. The folding member 330 inserted for mutual connection of rotary bodies 320a and 320b is provided for the folding work of the cutting blade 500, revolving together with the rotary bodies 320a and 320b. When the folding work is not being performed, the folding member 330 is completely apart from folding body 313 and is moved towards an upper side. These operations are performed by the driving unit 400 mentioned later.

[0023] Although two folding members 330 are shown in the drawings, for exemplary purposes, only one can be set.

[0024] Referring now to FIGS. 2 and 4, driving unit 400 includes a first driving unit 410 provided to revolve the rotary bodies 320a and 320b and a second driving unit 420 provided to move folding member 330 upwards and downwards from the folding body 313. The first driving unit 410 includes first toothed portions 411a and 411b which are fixed at both ends of a rotating shaft 418 which is rotatably within the supporting frames 301a and 301b. Second toothed portions 413a and 413b which are set on the outer circumference surface of the revolving bodies 320a and 320b are configured to mesh with the first toothed portions 411a and 411b. A servo motor M is operatively connected to the rotating shaft 418. The second driving unit 420 is a cylinder 421 connected to one end of the folding member 330 to be moved upwards and downwards for the purpose of performing an expansion operation. As an operating source of the cylinder 421 any one of either oil-hydraulic pressure or air pressure can be used.

[0025] FIG. 5 is a cross-sectional view taken along a line I-I of FIG. 2. FIG. 6 is a longitudinal sectional view taken along a line II-II of FIG. 5. Folding member 330 has a substantially triangular shape, which enables the cutting blade 500 to be folded easily even without applying an immoderate force. To fold the cutting blade 500 easily, an application of any other shape excepting the triangulate shape doesn't matter. On any one side of the guiding entrance 311 of the fixing body 313, which is supported to enable passing of the cutting blade 500, a fixation hole 340 is set. In the inside of the fixation hole 340, a steel wire spring 350 is set with one portion jutting out to a center position of the guiding entrance 311 through which the cutting blade 500 passes.

[0026] The steel wire spring 350 elastically supports the cutting blade 500 as it passes through the guiding entrance 311, and moves the cutting blade 500 within a predetermined channel, thereby heightening a precision of the folding work. Also, by setting a magnetic substance instead of the steel wire spring 350, the same effect as the steel wire spring can be achieved.

[0027] Though FIG. 5 shows, as an example, a structure in which the steel wire spring 350 is set on any one side of the guiding entrance 311, it is contemplated that it may be positioned on both sides. As shown in FIG. 6, the folding member 330 is extended when the cylinder 421 is driven, and is inserted into the guide holes 323a and 323b inside rotary bodies 320a and 320b, which are formed in the housing units 318a and 318b of the round shape of the fixing body 310 for rotational movement therein. When the rotary bodies 320a and 320b are rotated, the folding member 330 is integrally rotated along the guide slots 316a and 316b together with the folding member 330.

[0028] An operation embodiment of the folding system and an effect according to the present invention with the construction as above-mentioned are re-explained in detail referring to FIGS. 1 to 6.

[0029] The cutting blade 500 wound in a roll shape is transferred to the folding unit 300, which performs the folding work, by the transferring unit 10, having a transfer roller, through the cutting molding unit 100 and the guide nozzle 201. At this time, the cutting molding unit 100 performs a cutting work for cutting the cutting blade 500, passing through the cutting molding unit 100, in the length necessary for the sheet matter molding. Herewith, the cutting tip 503 is kept and maintained on the cutting blade 500 without detachment from the cutting portion 501 of the cutting blade 500. This is to prevent damage to blade unit 505 which may be caused by a collision during a transfer of the cutting blade 500 through the guide nozzle 201. The cutting molding unit 100 is applied from Korean Patent No. 80607 issued to the present applicant, and, therefore, the detailed operating description thereof is omitted.

[0030] Even if the cutting tip 503, formed on the cutting blade 500, is detached from the cutting molding unit 100, the cutting tip 503 passes through the guide nozzle 201 continuously and thereby there is no cause for its detachment. As shown in FIGS. 2 and 4, the cutting blade 500 passed through the guide nozzle 201 pierces through the guiding entrance 311 of the fixing body 313, and then goes out to the outer side of the supporting frames 301a and 301b.

[0031] The cutting blade 500 passing through the guiding entrance 311 contacts with the steel wire spring 350 as shown in FIG. 5, but the steel wire spring 350 has an elastic force, so it doesn't become an obstacle to pass the cutting blade 500 at all. The steel wire spring 350 is provided to support the cutting blade 500 with the elastic force to dampen or prevent a fluctuation in the cutting blade 500 which may be caused by a sudden stop of the transfer roller 10. The cutting blade 500 passed through the guiding entrance 311 is then folded in the shape suitable to a molding of the sheet material. In folding the cutting blade 500, the transfer roller 10 stops and the transferring work of the cutting blade 500 is temporarily in a stopped state. At the same time as the stop of the transfer roller 10, the second driving unit 420 between the driving units 400 operates first.

[0032] If only one cylinder 421 out of the second driving unit 420 falls in the operation, the second driving unit 420 remains situated in a position as shown in FIG. 2. The folding member 330 of one body with the cylinder 421 is inserted into the guide holes 323a and 323b inside of the rotary bodies 320a and 320b as shown in FIGS. 4 and 6, and is also situated on any one side of the fixing body 313 adjacent to the cutting blade 500. The guide holes 323a and 323b are formed on the same position, therefore the folding member 330 is inserted naturally when the cylinder 421 performs the falling operation. When the folding member 330 moved and is completed in moving to the position adjacent the cutting blade 500, the first driving unit 410 operates. The first driving unit 410 is rotated by driving the servo motor M. By driving the servo motor M, the first toothed portions 411a and 411b are simultaneously rotated by means of the rotating shaft 418. By a meshing operation between the first toothed portions 411a and 411b and the second toothed portions 413a and 413b, the revolving bodies 320a and 320b are rotated about a supporting point of the fixing body 310. When the revolving bodies 320a and 320b are rotated, the folding member 330 is also rotated. That is, the folding member 330 is rotated and moved

around a periphery of the fixing body 313 along the guide slot 316b from any one side of the fixing body 313 for the folding operation as shown in FIG. 5. At this time, the moved folding member 330 contacts with the cutting blade 500 which extends through the guiding entrance 311, thereby the cutting blade 500 is naturally folded by a rotating force of the folding member 330 along a slant face 312 of the fixing body 313. Meanwhile, the cutting tip 503 put on the cutting blade 500 is automatically separated by a tare and is collected when the cutting blade 500 extends through the outside of the guiding entrance 311.

[0033] Since the servo motor M stops the operation when the cutting blade 500 completes the folding, an immoderate rotation force of the rotary bodies 320a and 320b connected with the folding member 330 is not required. When the folding work of the cutting blade 500 is completed, the folding member 330 returns to an original position by an operation of the cylinder 421 of the second driving unit 420 as shown in FIG. 2. When the transfer roller 10 begins to operate again, the cutting blade 500 moves to the outer side of the guiding entrance 311 of the fixing body 313. While in that position, if a need exists to fold a predetermined unit of the cutting blade 500 in a direction opposite that which was described above, an operation of the transfer roller 10 stops, and at the same time the other folding member 330 falls and moves, and then the same steps as discussed above are repeated. As long as the cutting blade 500 is supplied, it may continuously be formed into any desired configuration. In the above-mentioned embodiment, though each step is explained separately for the understanding of the step for the folding work of the cutting blade, all processes such as a supply, a cutting, a folding work of the cutting blade, etc. can be performed by an automation controlled by a computer, etc.

[0034] As afore-mentioned, according to the present invention, all works necessary for the cutting and the folding of the cutting blade in the shape corresponding to the sheet material molding are performed in succession by one process with a unified construction, thereby resulting in an improvement of the cutting and folding works of the cutting blade and a productivity increase.

[0035] While only certain embodiments of the invention have been specifically described herein, it will apparent that numerous modifications may be made thereto without departing from the spirit and scope of the invention.

1. A bending apparatus comprising:

- a transferring unit for transferring a metallic rule through a passage formed by a guide, said passage defining a longitudinal axis;
- a folding unit having first and second rotary bodies spaced to receive said metallic rule therebetween; and
- a pair of bending fingers including a first bending finger and a second bending finger, said pair of bending fingers supported to revolve and move in a direction substantially transverse to the longitudinal axis for applying force against the metallic rule passing through the guide, said pair of bending fingers positioned adjacent to the guide, and for bending the metallic rule to desired angles, wherein each finger of said pair of bending fingers is each configured for arcuate rotational motion relative to said guide from a first position toward at least one second position to bend a portion of said metallic rule, and

wherein said pair of bending fingers rotate about a single rotational axis relative to said guide.

* * * * *