

(No Model.)

B. C. ROWELL.

AUTOMATIC TRAIN PIPE VENT VALVE FOR AIR BRAKES.

No. 584,963.

Patented June 22, 1897.

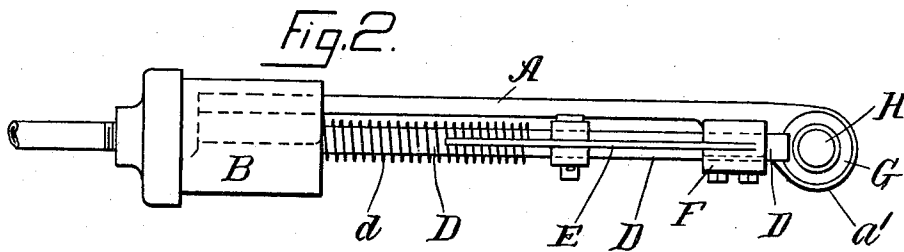
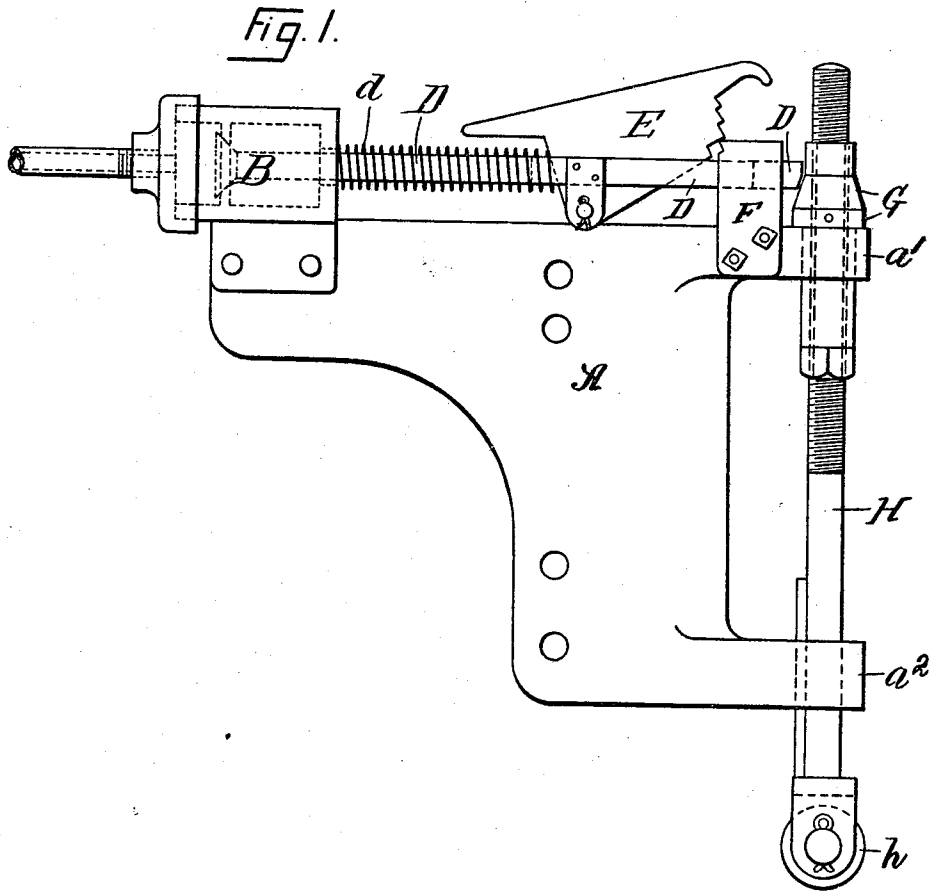

WITNESSES:

A. V. Emilio.
John Brown.

INVENTOR

Benton C. Rowell

BY

Maynard & Mitchell,

his ATTORNEYS.

UNITED STATES PATENT OFFICE.

BENTON C. ROWELL, OF BOSTON, MASSACHUSETTS, ASSIGNOR TO THE ROWELL-POTTER SAFETY STOP COMPANY, OF PORTLAND, MAINE.

AUTOMATIC TRAIN-PIPE VENT-VALVE FOR AIR-BRAKES.

SPECIFICATION forming part of Letters Patent No. 584,963, dated June 22, 1897.

Application filed October 12, 1896. Serial No. 608,548. (No model.)

To all whom it may concern:

Be it known that I, BENTON C. ROWELL, of Boston, Suffolk county, Massachusetts, have invented an Improved Automatic Train-Pipe Vent-Valve for Air-Brake Systems, of which the following is a specification, reference being had to the accompanying drawings, in which—

Figure 1 is a side elevation of my mechanism. Fig. 2 is a plan.

Stop systems for the protection of railways in which by means of a track member secured close to the track and a train member secured upon the train cooperating with the track members the train-pipe of an air-brake system might be vented and the brakes set when the train member was brought in contact with the track member are well known, such a system in which the track member is an inclined plate being shown in my Patent No. 534,244, dated February 12, 1895.

My present invention is an improved train member for use in such a combination.

In the drawings, A is a frame-plate having bolt-holes by which the frame-plate and the parts carried by the frame-plate may be secured to the locomotive or to a car in a suitable position to cooperate with the track member, as will be plain without more description.

B is the valve, of any suitable construction, one form of which is shown in dotted lines in Fig. 1, the opening of which vents the train-pipe, causing the brakes to be set.

D is the valve-stem, and *d* a spring which tends to return the valve to its seat when forced off it.

E is a detent fulcrumed upon a lug fast to the valve-stem, the fulcrum being below the line of the stem and the end of spring *d* pressing upon one end of the detent E and tending always to throw the other end of the detent down.

F serves as a support for valve-stem D, and also serves as an abutment for the detent E. The free end of valve-stem D is suitably beveled and is nearly in contact with the cam-surface of a cam-nut G, which is supported by a bracket *a'*, fast to frame-plate A. The

cam-nut G consists of a nut proper carrying the frustum of a cone. The contact-stem H is supported by the cam-nut G, being guided at its lower end by a bracket *a*², fast to frame-plate A, and having a feather working in a groove in bracket *a*² to prevent the turning of the contact-stem. The cam-nut G and contact-stem H are connected together by screw-threads upon the stem H and within the nut G. Upon the bottom of stem H is mounted a roll *h*, which is designed to come in contact with the cam-surface of the track member.

The operation of the mechanism is as follows: When the roll *h* strikes the cam-surface of the track member, the stem H is forced up, and the cam-surface of nut G forces valve-stem D and its valve back against the force of the air contained in the train-pipe and of spring *d*, detent E dropping under the force of gravity and of spring *d* and preventing the valve closing again. When it is desired to close the valve again, the detent E is tripped and spring *d* returns the valve to its seat.

It will be obvious that for various reasons some degree of adjustability of the contact-stem H is highly desirable, as the adjustment of the track members may vary upon different sections of railway, and also that the mechanism when first applied to an engine may be secured permanently and the adjustment be made afterward. My present invention provides this adjustability by means of the cam-nut G, the turning of the cam-nut raising or lowering the contact-stem H, as may be desired, the cone shape of the cam-surface of cam-nut G always presenting a proper face to the cam-surface of valve-stem D.

What I claim is—

The automatic train-pipe vent-valve above described, consisting of a valve; a valve-stem; a detent; a screw-threaded contact-stem carrying a cam-nut; that cam-nut and means to support the parts in their proper relation, all organized substantially as described.

BENTON C. ROWELL.

Witnesses:

F. W. BRINCKERHOFF,
W. LUXMORE.