



US 20120102635A1

(19) **United States**

(12) **Patent Application Publication**
Cheng

(10) **Pub. No.: US 2012/0102635 A1**

(43) **Pub. Date: May 3, 2012**

(54) **MULTI-USER PORTABLE TOILET**

(52) **U.S. Cl. 4/476**

(76) **Inventor: Kevin Cheng, San Francisco, CA (US)**

(21) **Appl. No.: 13/281,176**

(57) **ABSTRACT**

(22) **Filed: Oct. 25, 2011**

Related U.S. Application Data

(60) **Provisional application No. 61/407,805, filed on Oct. 28, 2010.**

Publication Classification

(51) **Int. Cl. A47K 11/04 (2006.01)**

An improved portable toilet for simultaneous, private use by two persons, the portable toilet which contains an internal compartment having a commode, a waste containment chamber disposed below the commode for receiving waste, an external shell enclosing the compartment and the waste containment chamber, at least one urinal disposed externally upon the external shell and drainage system connecting the external urinal to the waste containment chamber. The portable toilet of the present invention has a cross-section and footprint in the shape of a pentagon.

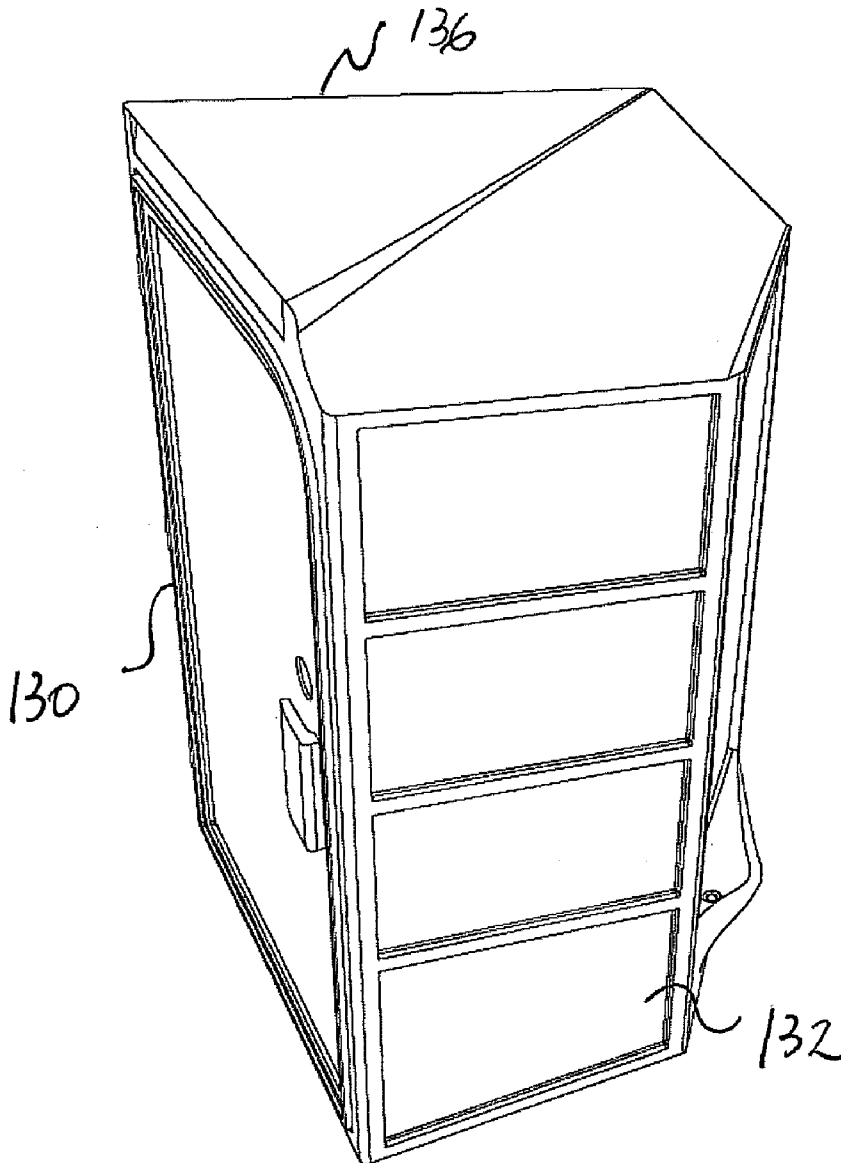

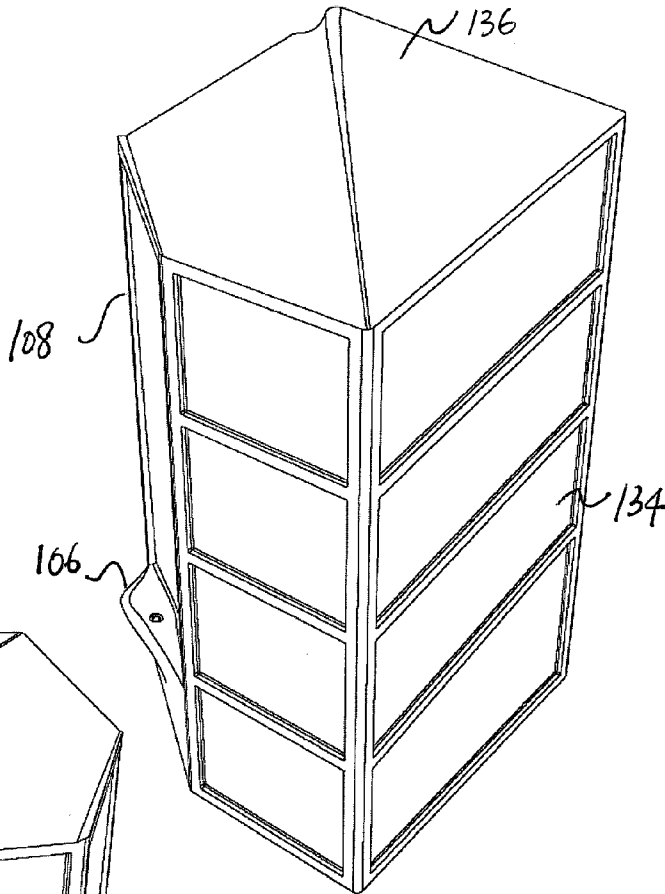
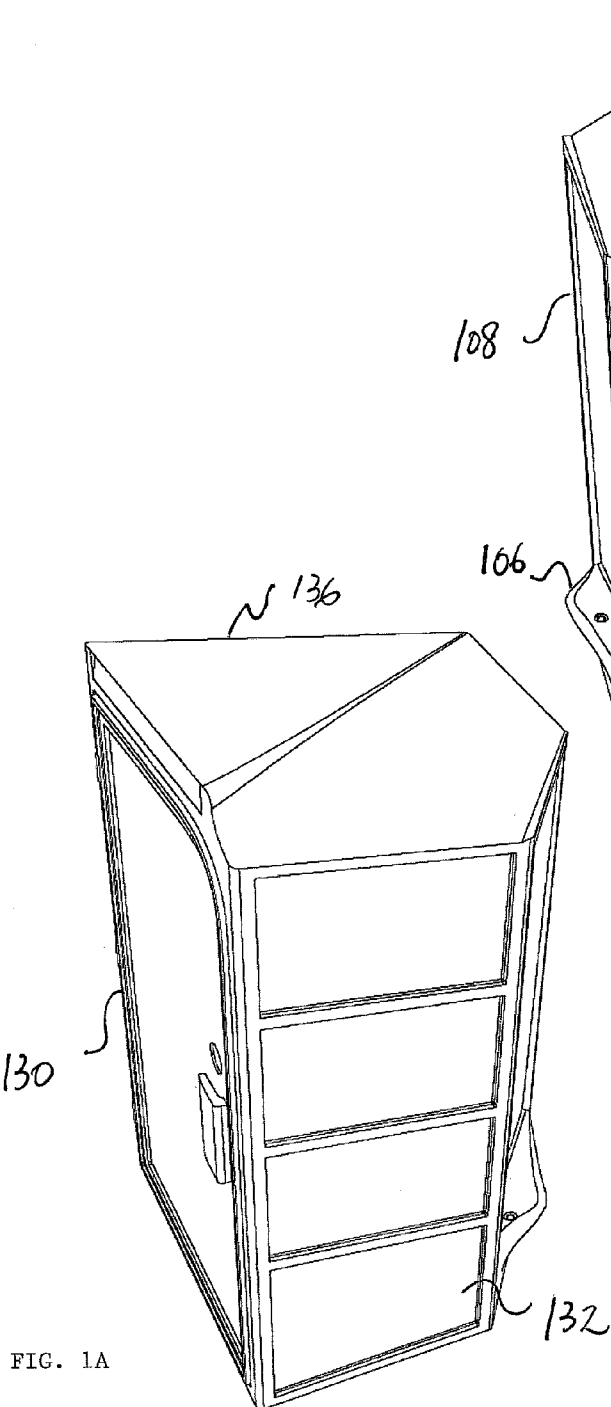

FIG. 1B

FIG. 1A

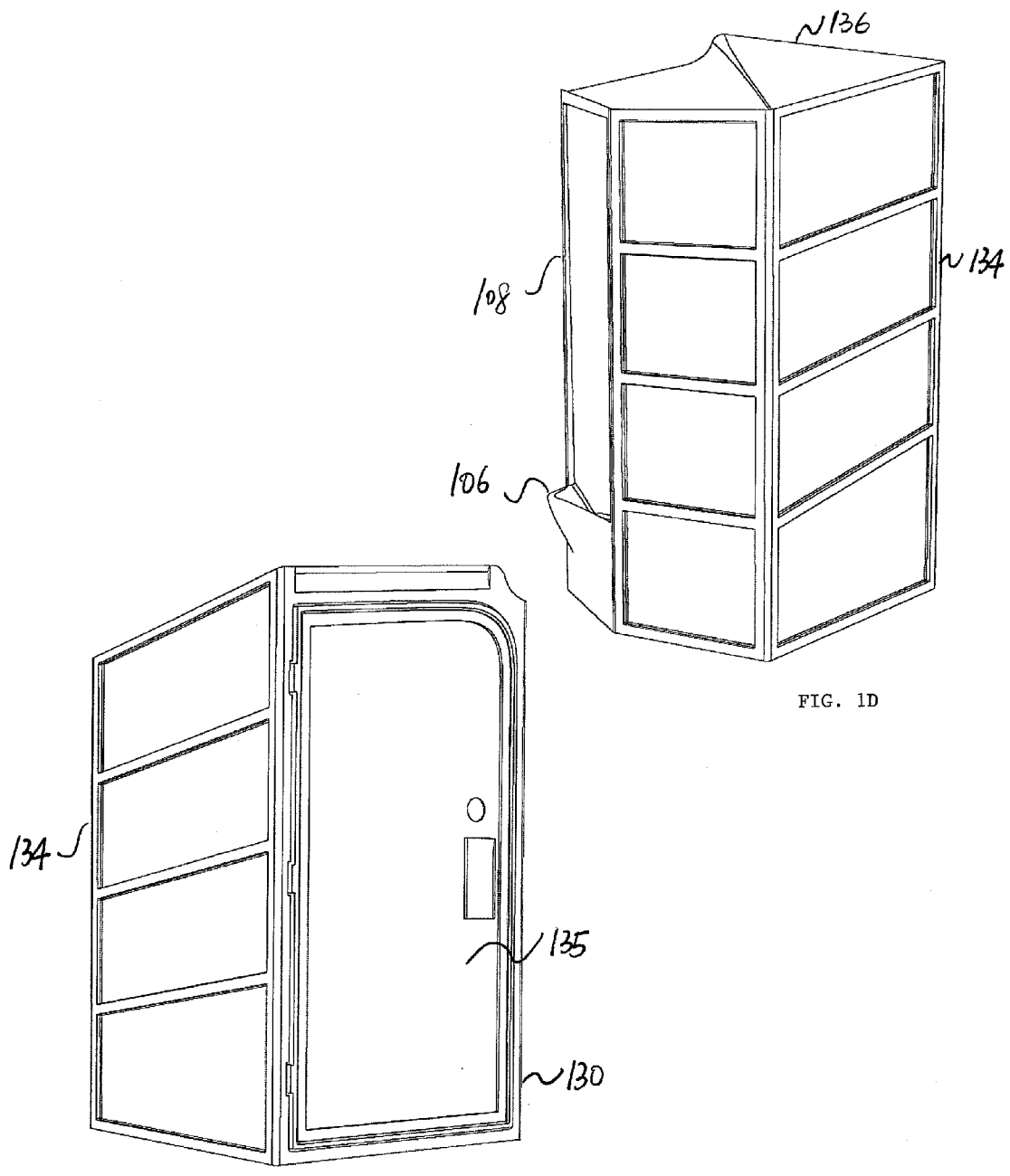

FIG. 1D

FIG. 1C

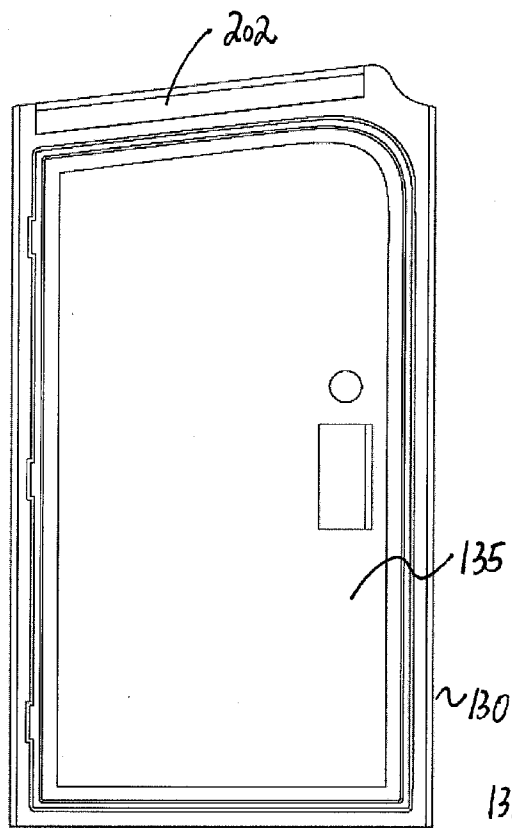

FIG. 2A

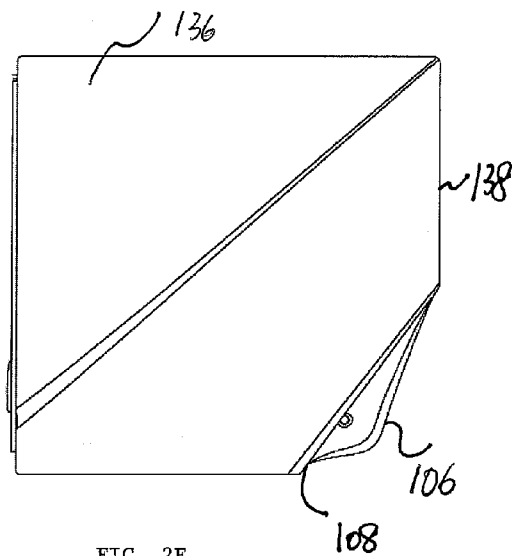

FIG. 2E

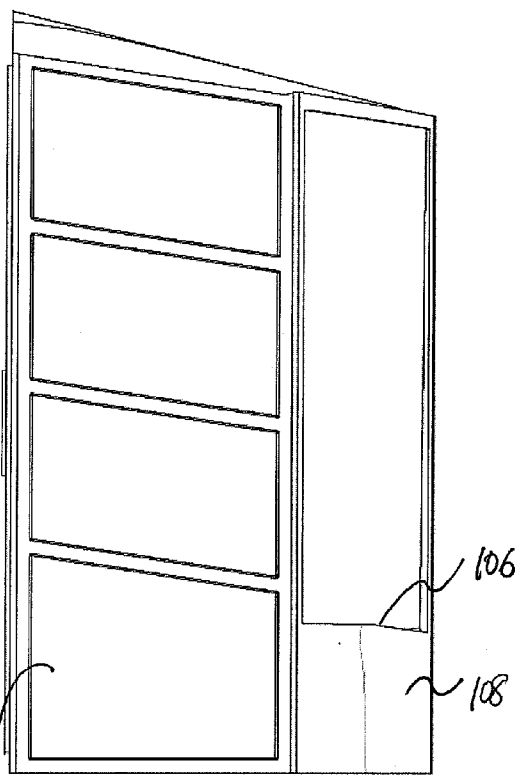

FIG. 2B

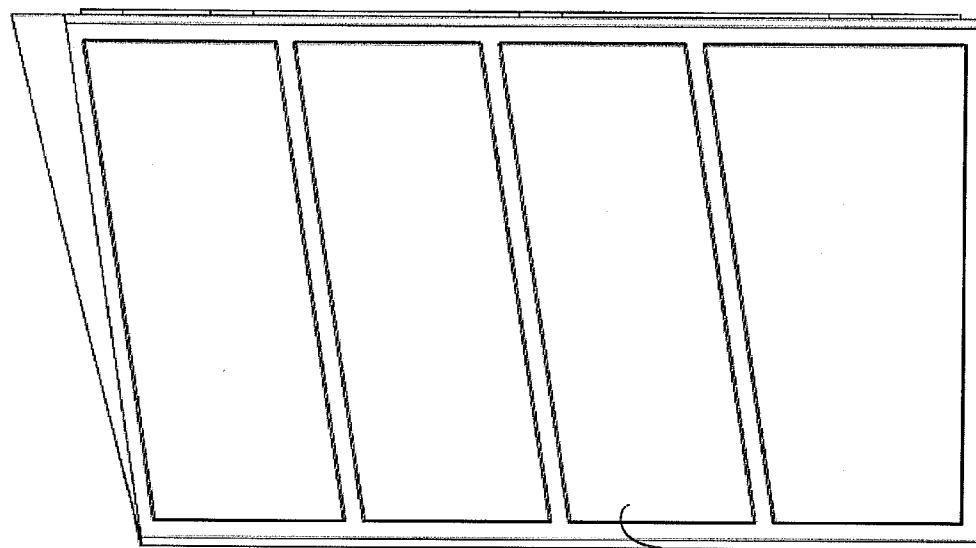

FIG. 2D

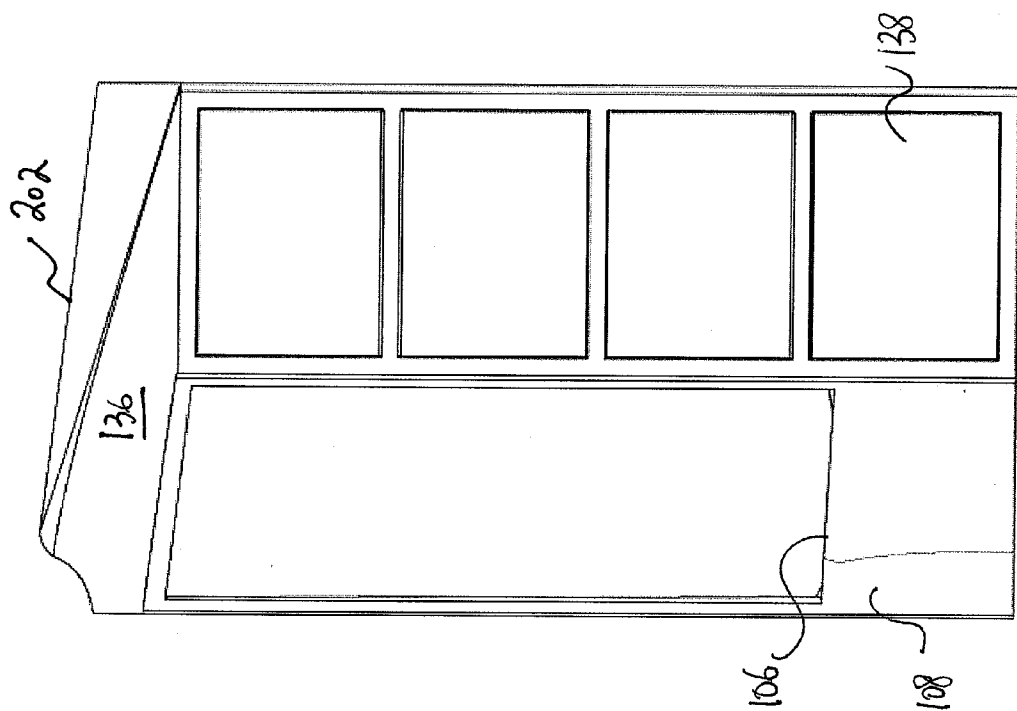

FIG. 2C

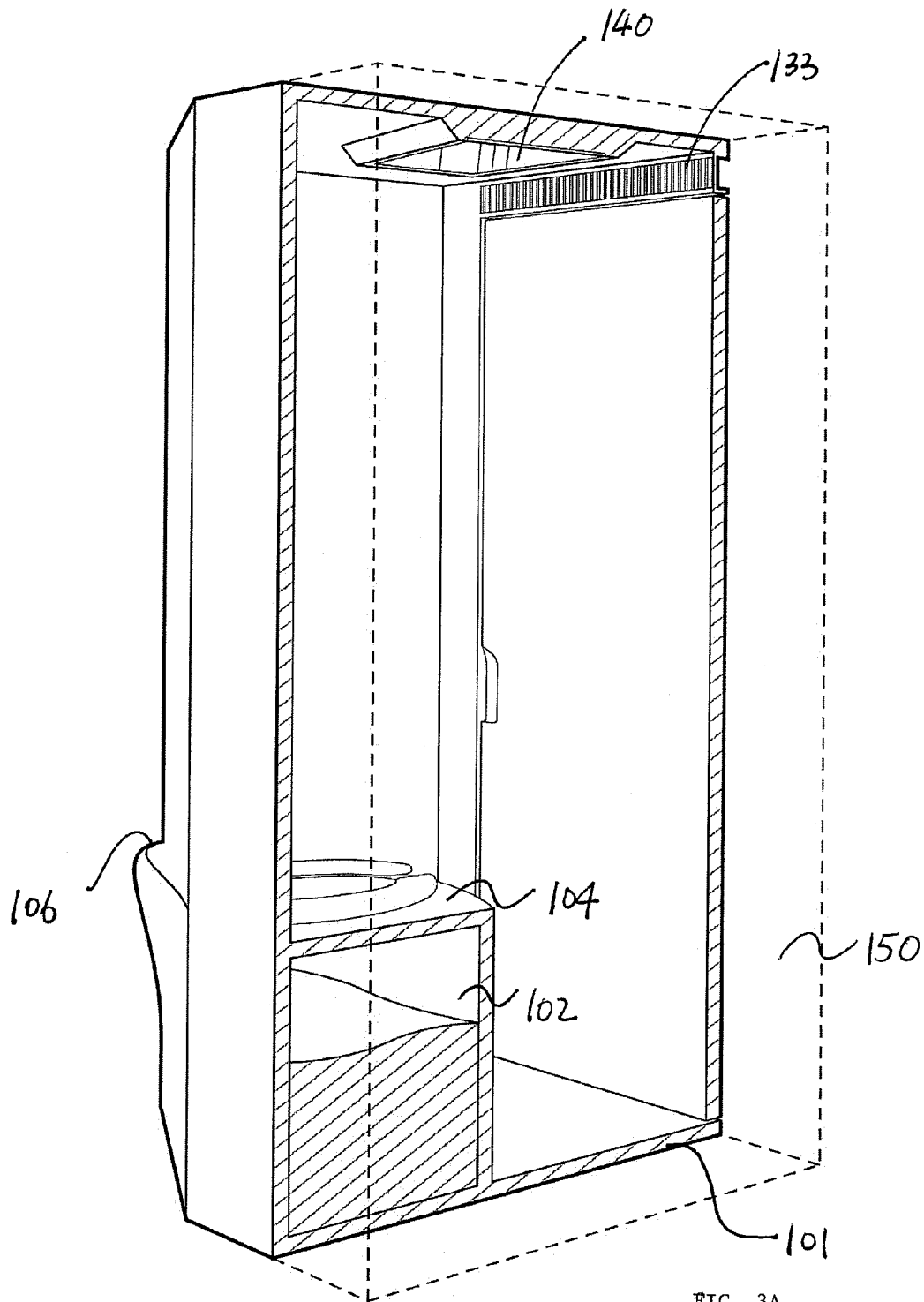

FIG. 3A

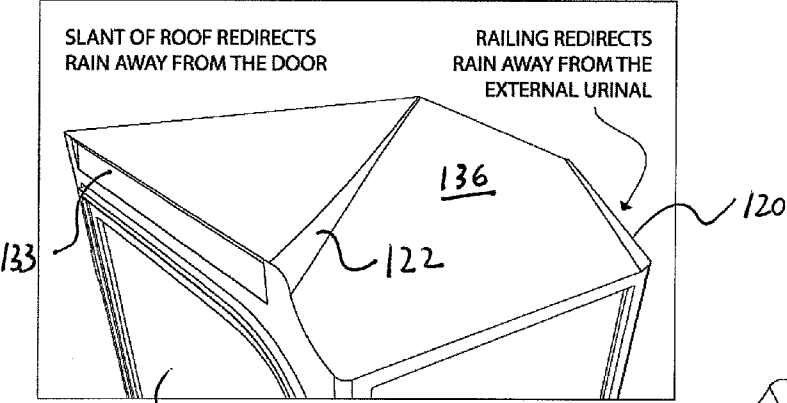

FIG. 3C

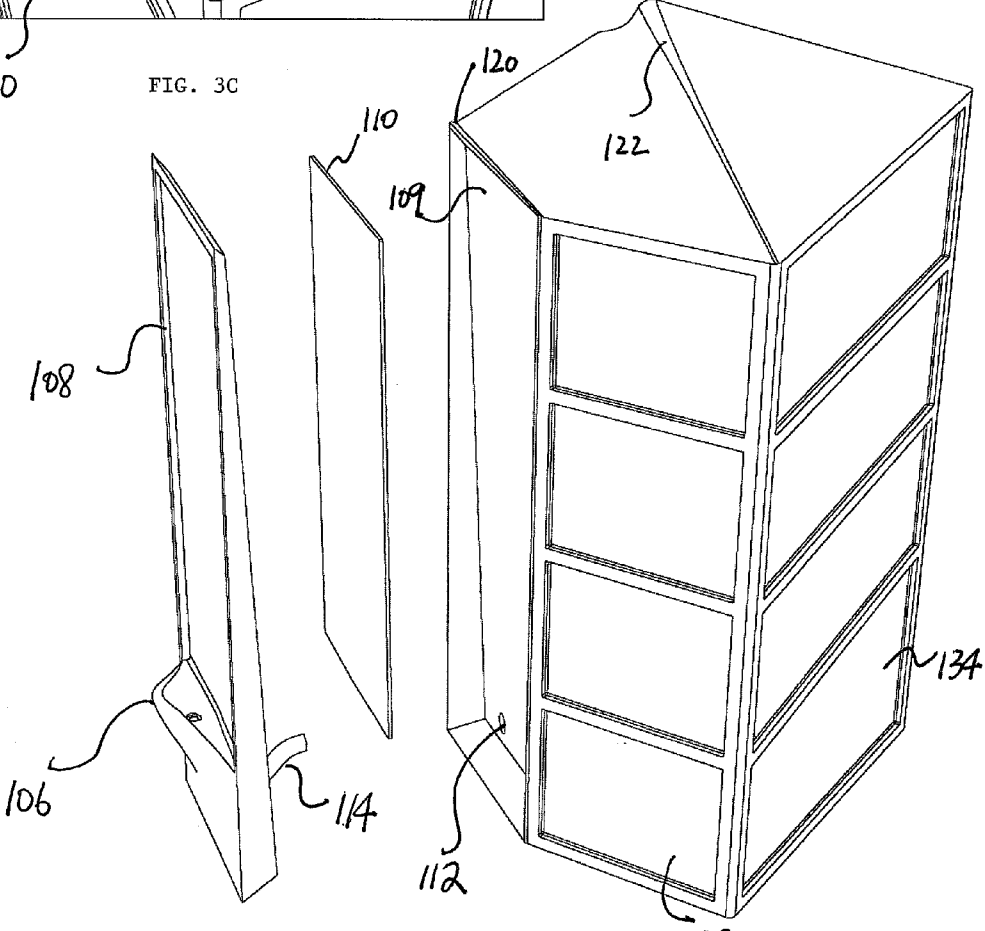

FIG. 3B

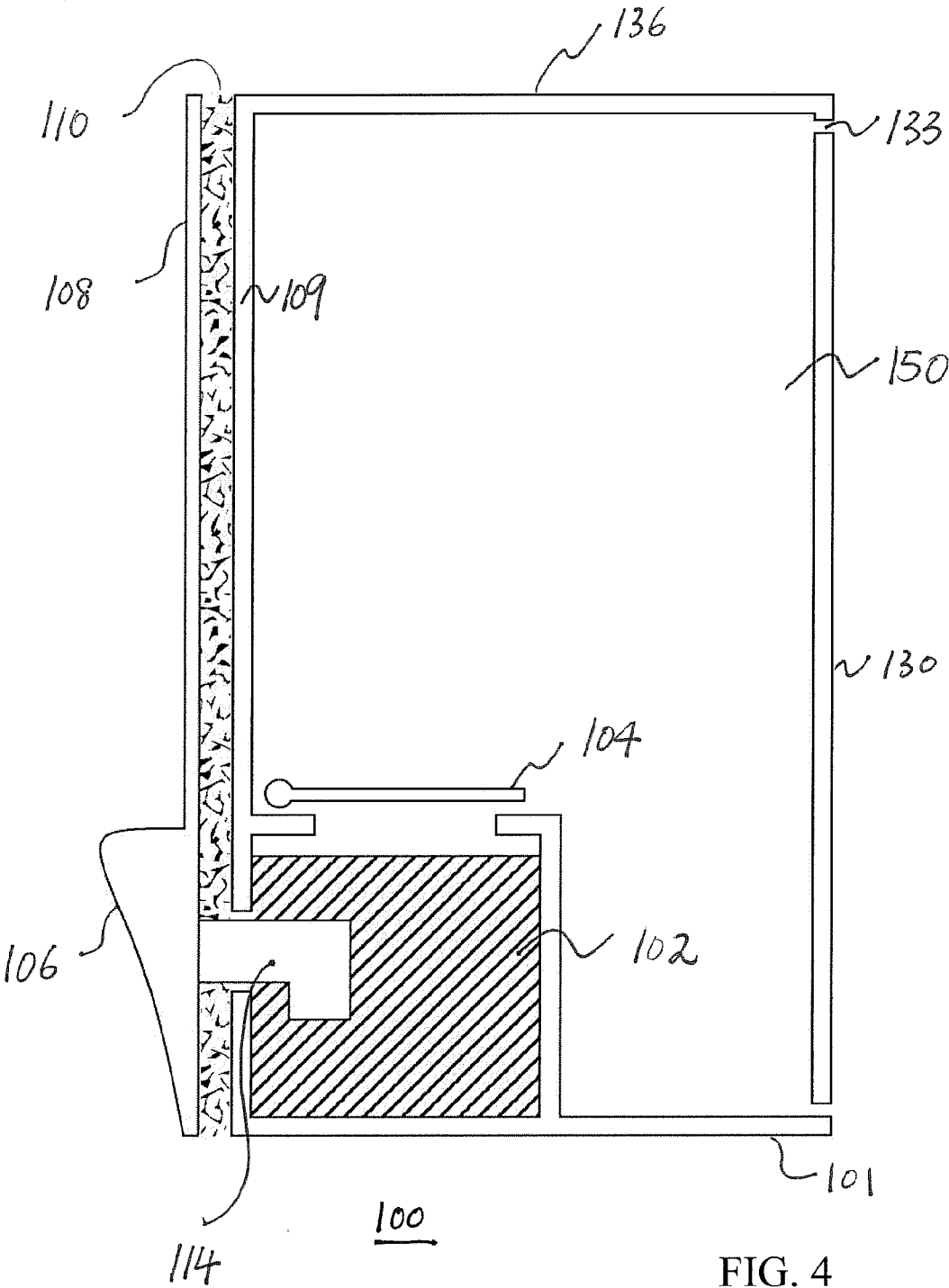

FIG. 4

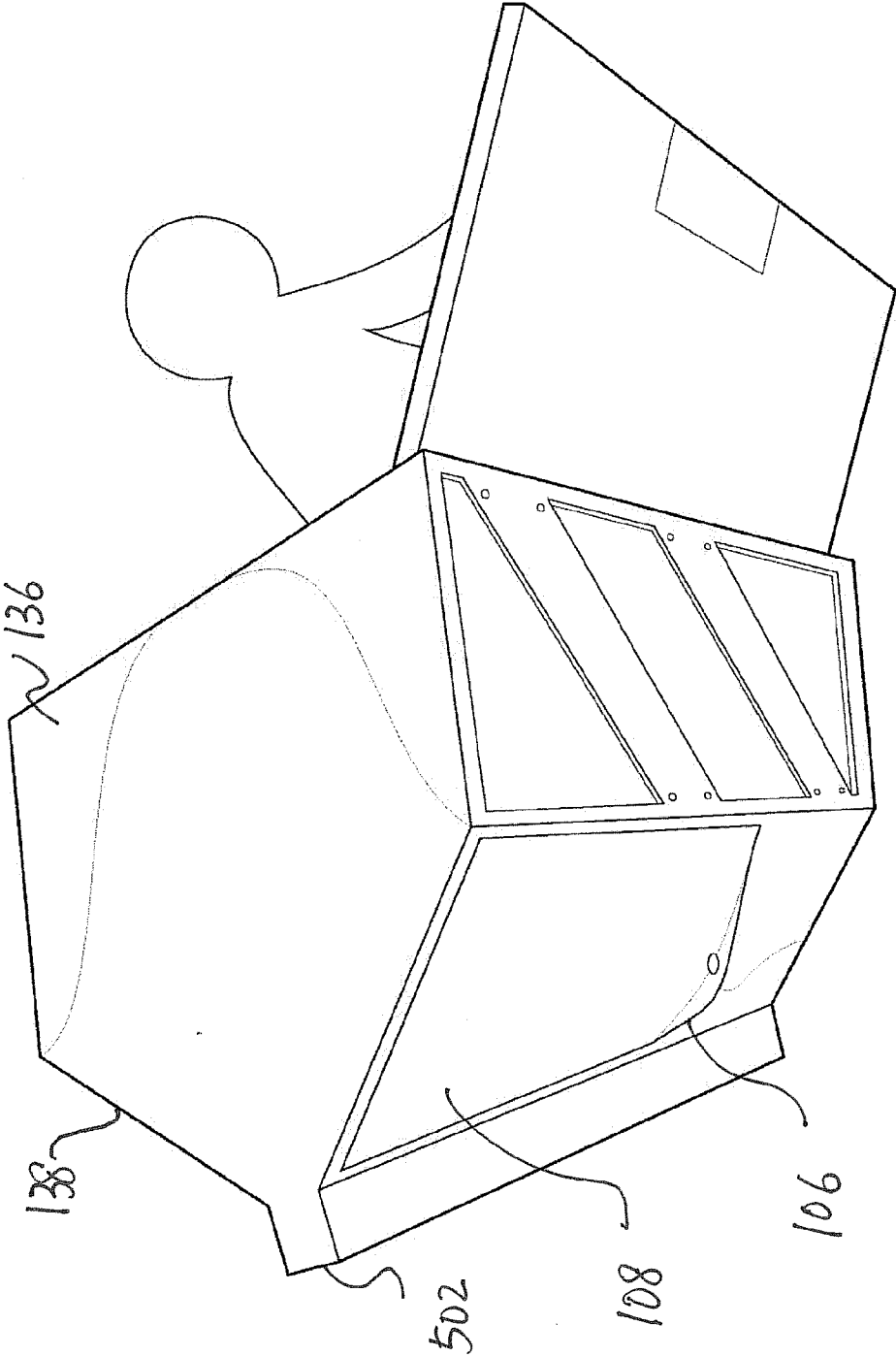

FIG. 5

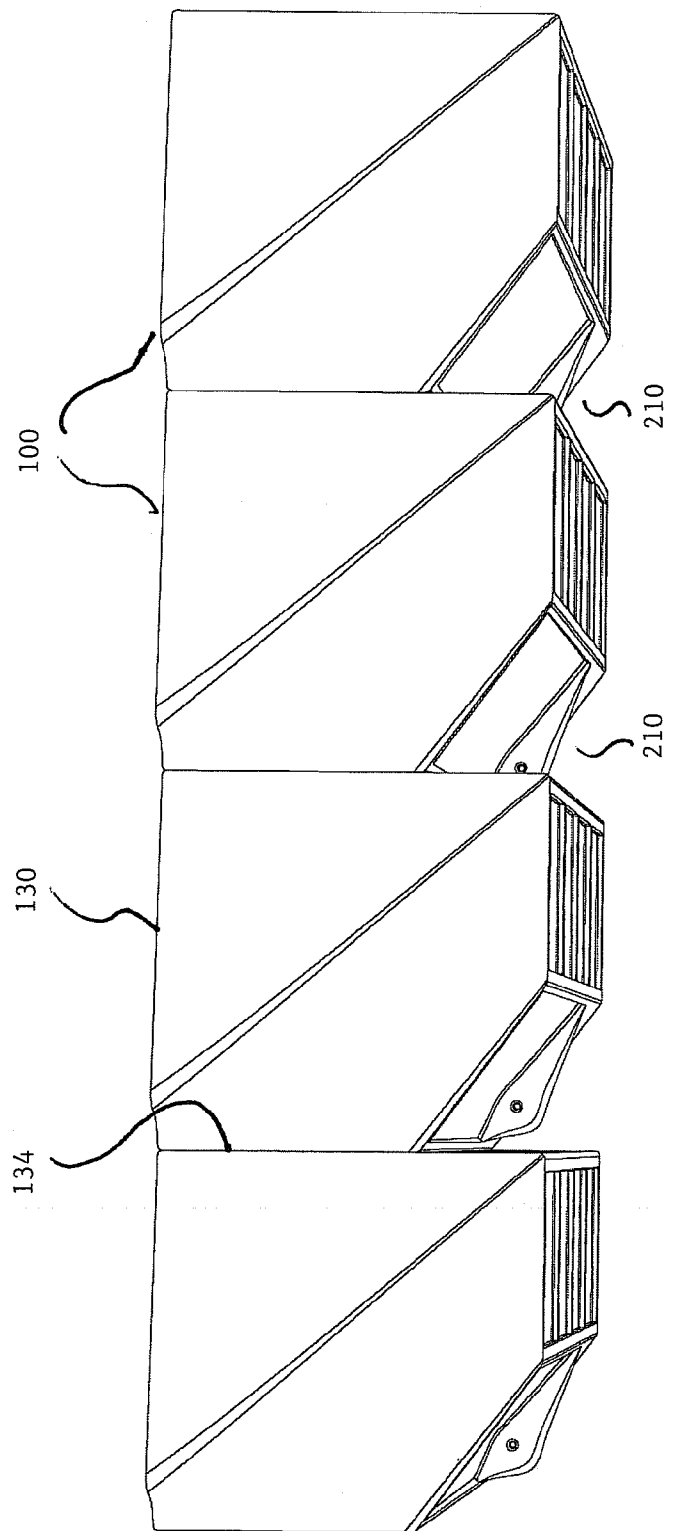

FIG. 6A

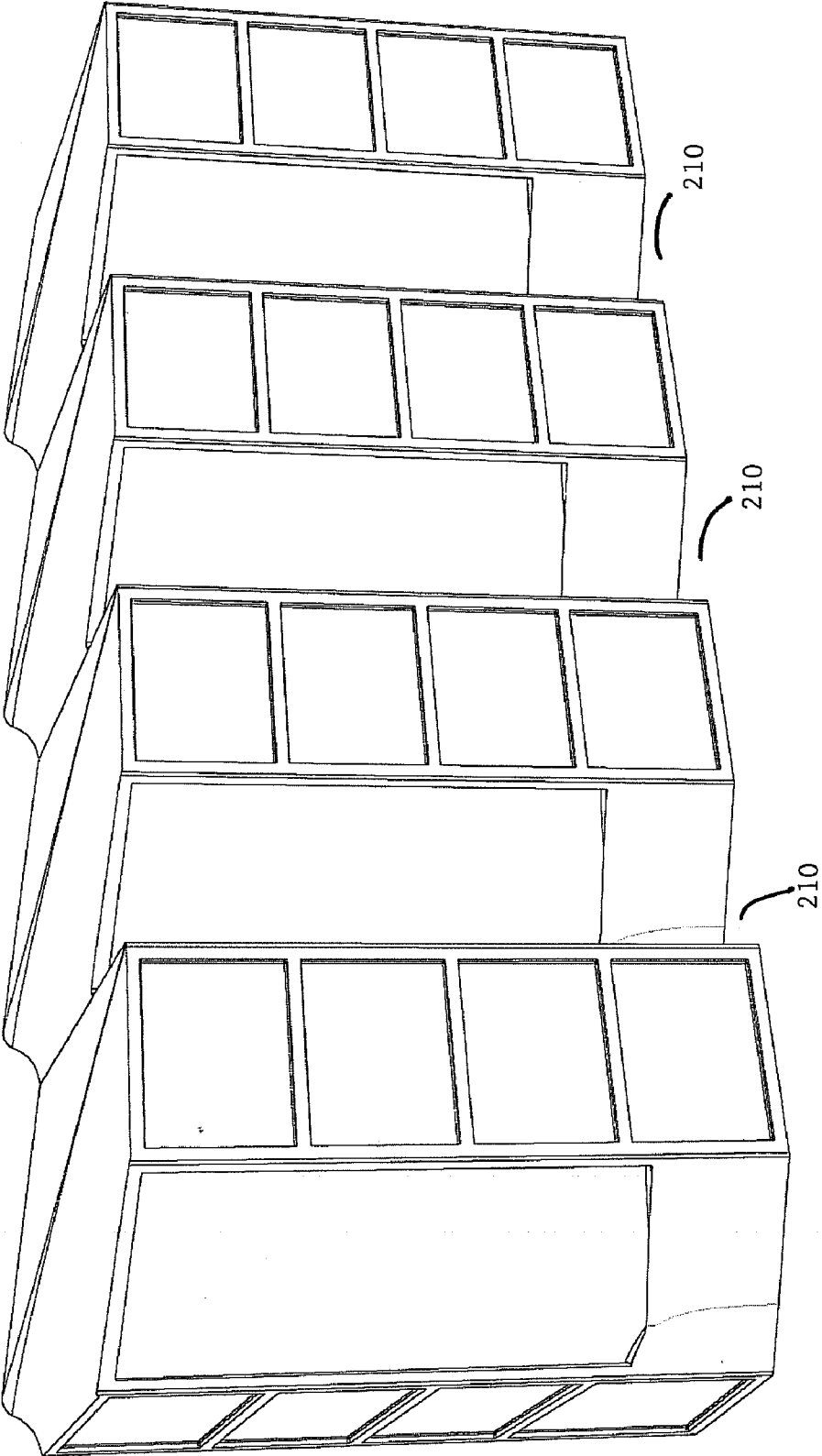

FIG. 6B

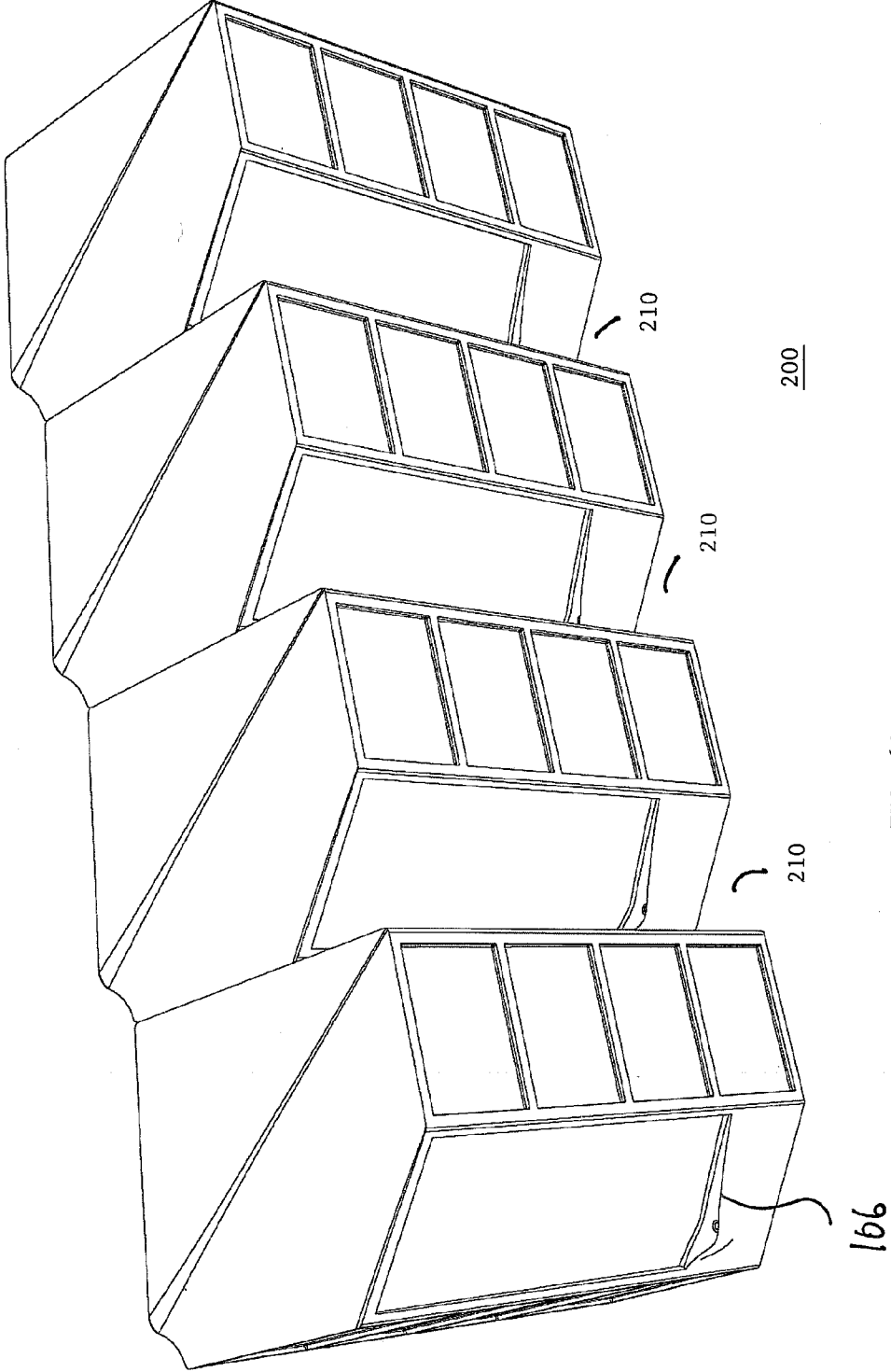
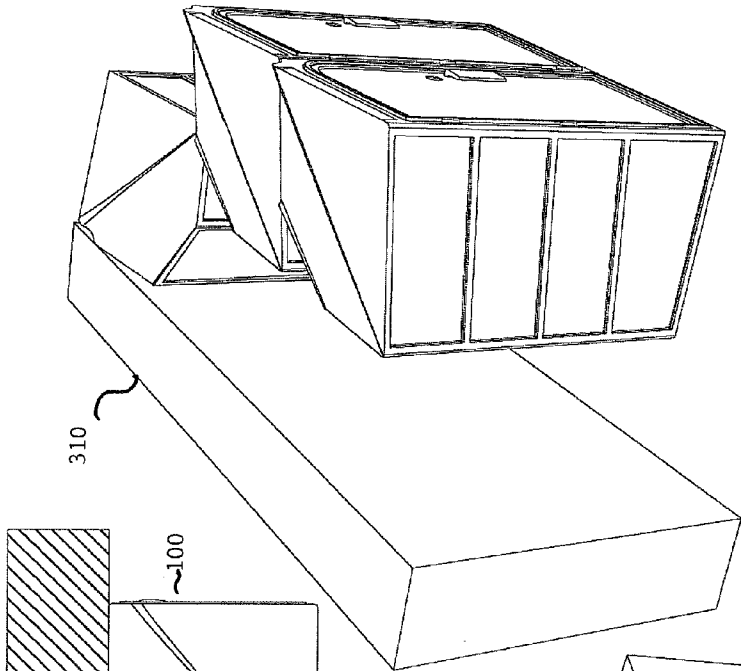

FIG. 6C



300

FIG. 7B

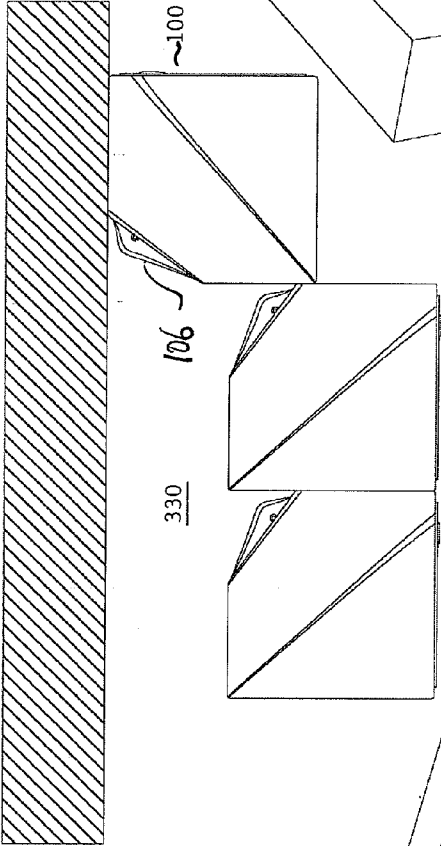
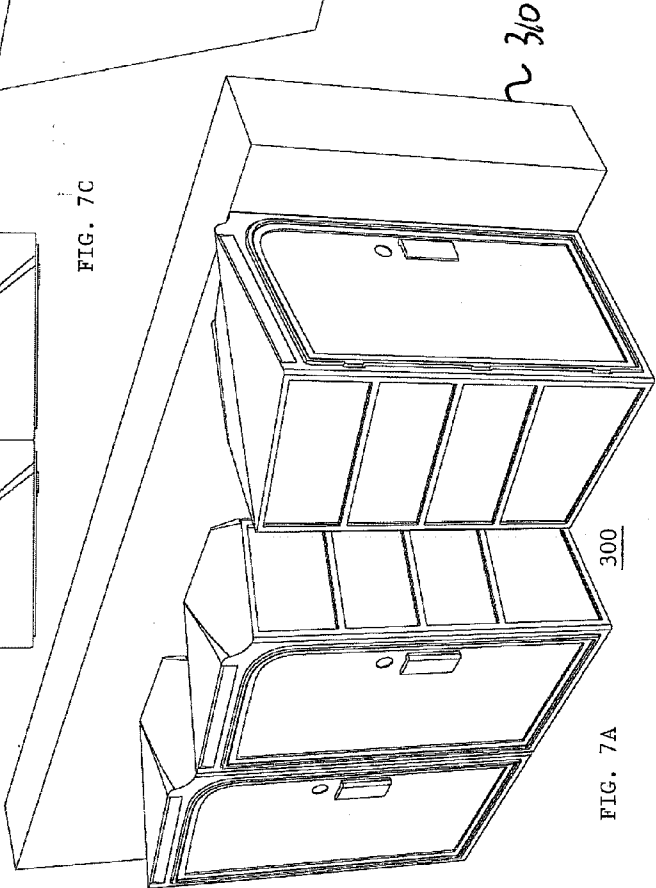

FIG. 7C



310

300

FIG. 7A

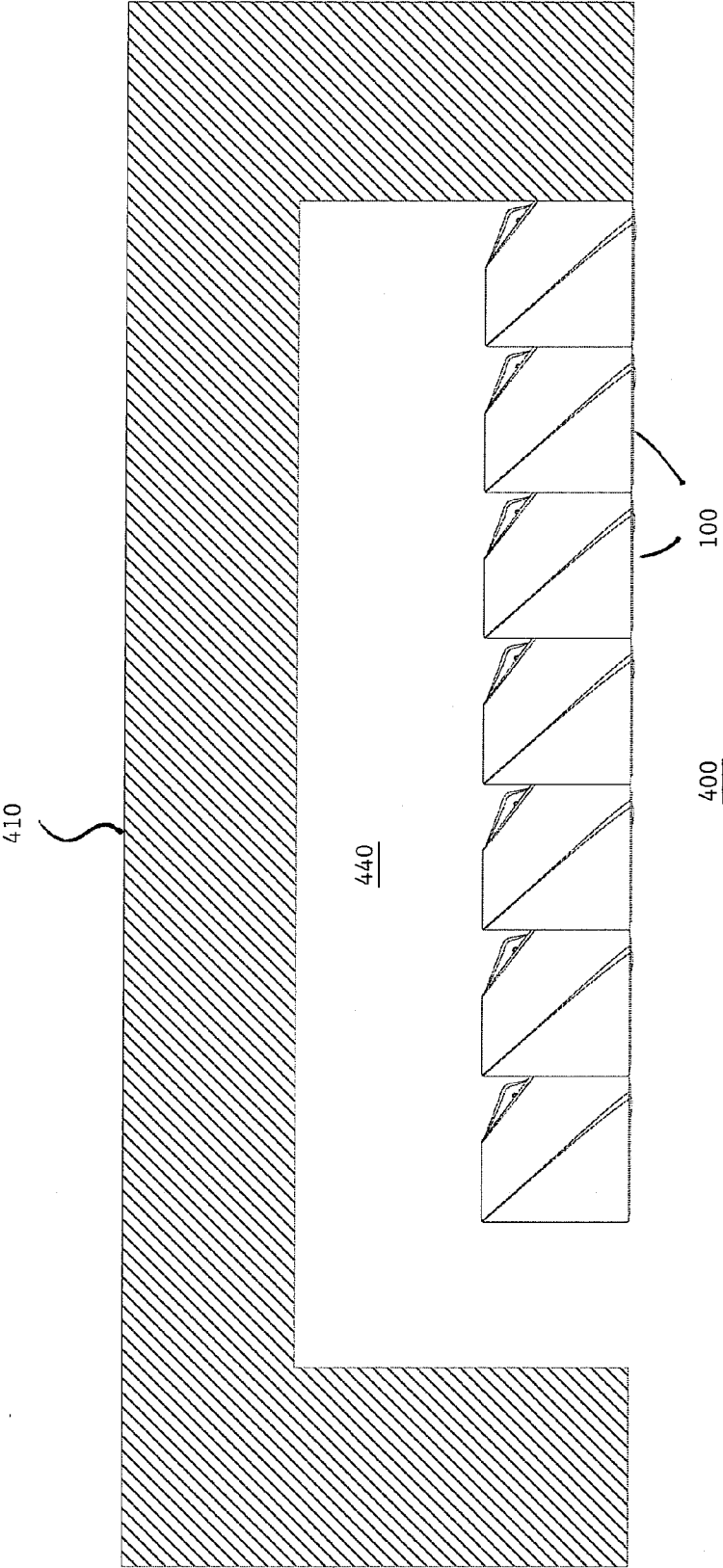

FIG. 8A

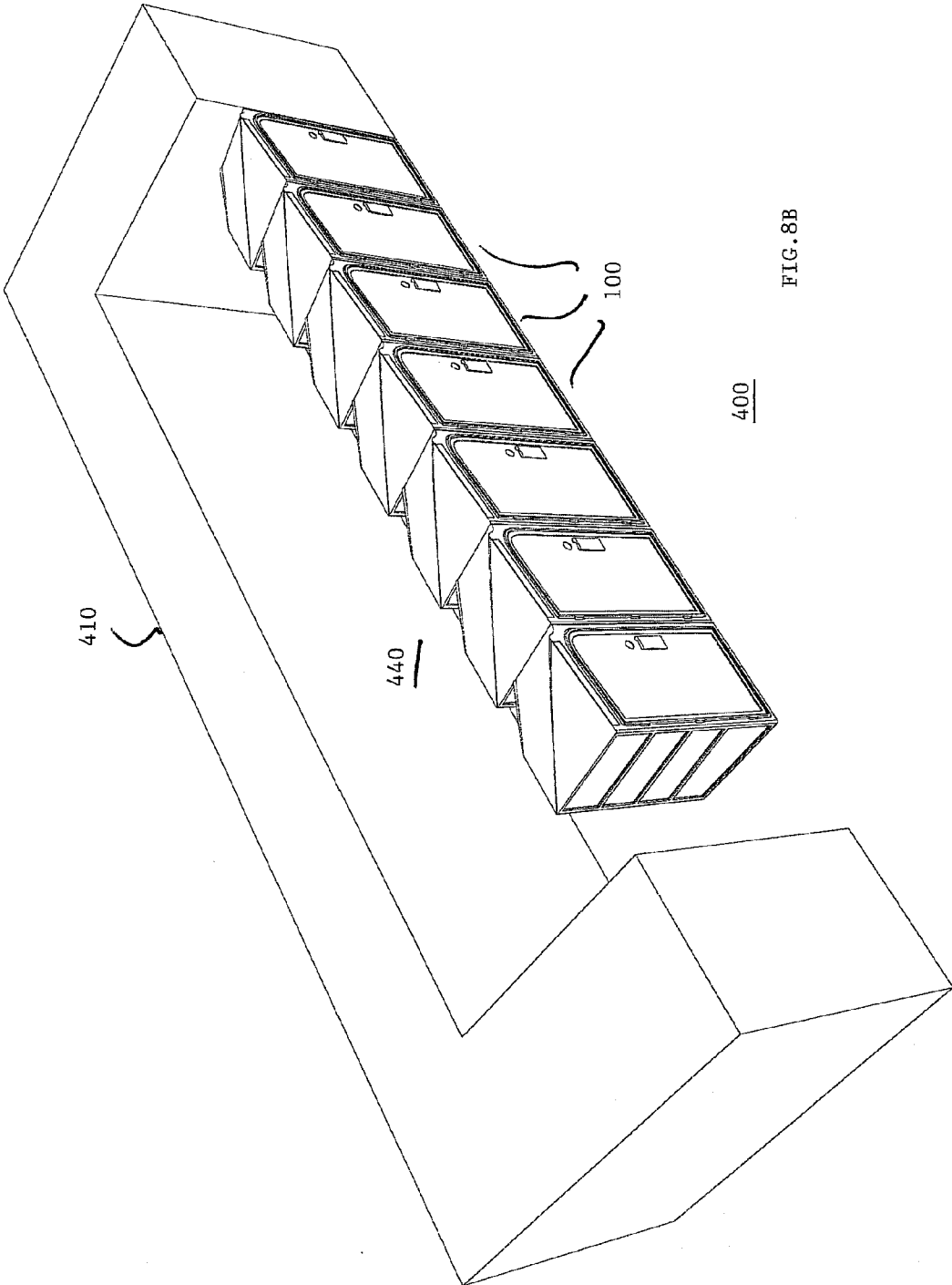

FIG. 8B

410

440

100

400

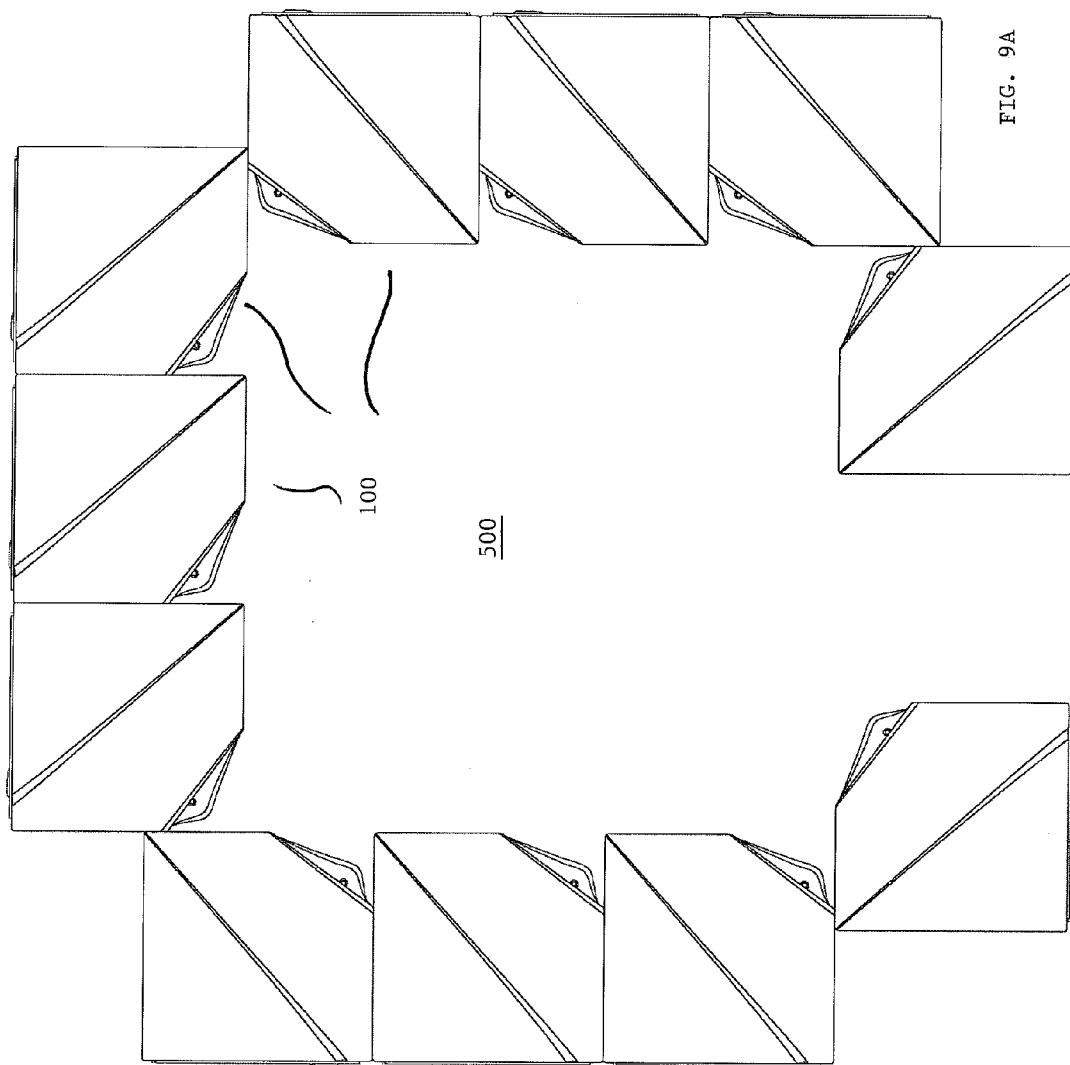

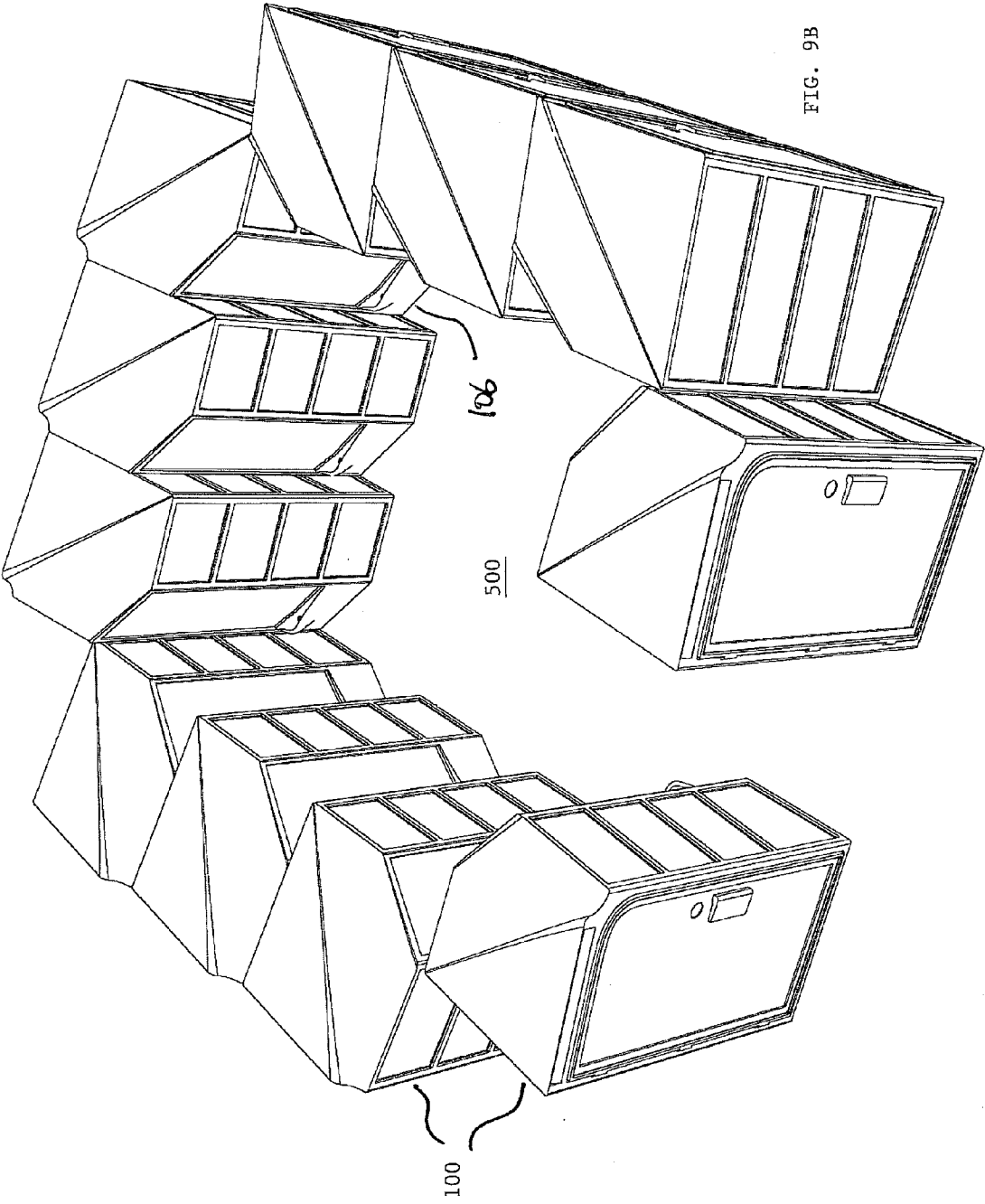

MULTI-USER PORTABLE TOILET

RELATED APPLICATIONS

[0001] This Application is a Nonprovisional Patent Application related to U.S. Provisional Patent Application Ser. No. 61/407,805 filed Oct. 28, 2010 entitled “MULTI-USER PORTABLE TOILET”, which is incorporated herein by reference in its entirety, and claims any and all benefits to which it is entitled therefrom.

FIELD OF THE INVENTION

[0002] The present invention relates to an improved multi-user portable toilet, and more particularly, to an outdoor portable toilet with external urinal, and arrangements thereof, to meet public needs more efficiently.

BACKGROUND OF THE INVENTION

[0003] Portable toilets are simple enclosures containing a chemical or holding tank-type toilet. They are typically used at construction sites, outdoor sporting events, fairs, markets, and other temporary or infrequent gatherings and events. Most portable toilets have the typical open-front-U-shaped toilet seat with cover with or without an optional internal urinal system. They are often constructed out of light weight molded plastic.

[0004] The present invention is part of the next generation of portable restrooms, designed to counter the problems that arise due to massive attendance at popular outdoor events such as concerts, fairs, and festivals. Large music festivals which generate traffic of up to 80,000 people per half day should provide up to 1,190 portable restroom units. This alone amounts to more than 26,000 square feet that the venue is required to set aside for the restroom area or areas. Often, events are unable to meet these quotas due to rental cost or space restraints, which result in long lines and rapidly degenerating hygienic conditions. Moreover, with long lines, impatience often leads to inappropriate behavior, such as users urinating on the nearby structure or landscaping.

[0005] Portable urinal units are brought in sometimes to meet overwhelming public demands at outdoor events. However, often these systems compromise the user’s privacy. Also, almost all portable urinal units need their own waste tank, which increases difficulty in cleaning.

[0006] U.S. Publication No. 20090235445, published Sep. 24, 2009 to Goldstein teaches an addition of an external urinal to a conventional portable toilet. It however fails to address the issue of privacy. Additional portable screens may be introduced to alleviate the associated problems, but add to installation and break down time and costs.

ADVANTAGES AND SUMMARY OF INVENTION

[0007] Through innovative use and placement of an external urinal, the present invention allows two people to use a single unit simultaneously, while maintaining privacy of both users. The present invention is a portable toilet assembly with an internal chamber, an external urinal and a shared waste container located beneath the internal chamber.

[0008] The simultaneous use of the present invention by 2 users drastically reduces wait times by redirecting urinal users to the back side areas of the units, an area which is generally un-used on the standard portable toilet. The present invention also has the ability to accommodate more users

with fewer units which not only reduces the amount of space needed for restrooms at outdoor events or other events in which sufficient indoor restroom facilities are lacking, but also reduces costs, thus allowing extra budget allowance to be spent elsewhere. With less units required per event, less are manufactured and transported, greatly reducing the carbon footprint of portable restrooms. The present invention’s external curvature design, integrated into both its overall form and into its structural support are reminiscent of water and gentle waves when multiple units are place side by side.

[0009] The portable toilets of the present invention can be arranged in rows, circular and other configurations to best suit the spatial and/or aesthetic requirements and considerations of the venue. Due to the unique design of the present invention, a singular unit in itself can provide acceptable privacy to users of the external urinal. When multiple units are arranged strategically, they create not only a natural private space for the external urinal users, but each adjacent unit provides additional privacy for all users.

[0010] Further details, objects and advantages of the present invention will become apparent through the following descriptions, and will be included and incorporated herein.

BRIEF DESCRIPTION OF THE DRAWINGS

[0011] FIGS. 1A through 1D are representative isometric views of an embodiment of the multi-user portable toilet 100 of the present invention.

[0012] FIGS. 2A through 2D are representative side views of an embodiment of the multi-user portable toilet 100 of the present invention. FIG. 2E is a representative top view of an embodiment of the multi-user portable toilet 100 of the present invention.

[0013] FIG. 3A is a representative cross-sectional view of an embodiment of the multi-user portable toilet 100 of the present invention showing the privacy compartment 150.

[0014] FIG. 3B is a representative isometric view of an embodiment of the multi-user portable toilet 100 of the present invention showing assembly of external urinal panel 108.

[0015] FIG. 3C is a representative top isometric view of an embodiment of the multi-user portable toilet 100 of the present invention showing the contour design of top panel 136.

[0016] FIG. 4 is a representative lateral, cut-away schematic view showing an embodiment of the portable toilet 100 of the present invention showing the internal commode, waste containment chamber, external urinal, drainage means connecting the external urinal to said waste containment chamber and acoustic insulation/sound-proofing disposed along the compartment shell to provide additional privacy for multiple simultaneous users.

[0017] FIG. 5 is a representative isometric view of an alternative embodiment of multi-user portable toilet 600.

[0018] FIG. 6A is a representative top side view of multiple multi-user portable toilets 100 of the present invention in a row arrangement 200.

[0019] FIG. 6B is a representative back side view of multiple multi-user portable toilets 100 of the present invention in a row arrangement 200.

[0020] FIG. 6C is a representative upper back side view of multiple multi-user portable toilets 100 of the present invention in a row arrangement 200.

[0021] FIGS. 7A through 7C are representative side top isometric and top views, respectively, of multiple multi-user portable toilets 100 of the present invention in a stall arrangement 300.

[0022] FIGS. 8A and 8B are the representative top and upper isometric views, respectively, of multiple multi-user portable toilets 100 of the present invention in a chamber arrangement 400.

[0023] FIGS. 9A and 9B are the representative top and upper isometric views, respectively, of multiple multi-user portable toilets 100 of the present invention in a ring arrangement 500.

[0024] For a better understanding of the invention reference is made to the following detailed description of the preferred embodiments thereof which should be taken in conjunction with the prior described drawings.

DETAILED DESCRIPTION OF THE PREFERRED EMBODIMENT

[0025] The description that follows is presented to enable one skilled in the art to make and use the present invention, and is provided in the context of a particular application and its requirements. Various modifications to the disclosed embodiments will be apparent to those skilled in the art, and the general principals discussed below may be applied to other embodiments and applications without departing from the scope and spirit of the invention. Therefore, the invention is not intended to be limited to the embodiments disclosed, but the invention is to be given the largest possible scope which is consistent with the principals and features described herein.

[0026] FIGS. 1A through 1D are representative isometric views of an embodiment of the multi-user portable toilet 100 of the present invention. In one embodiment, multi-user portable toilet 100 of the present invention is a simple portable enclosure consisting essentially of an internal toilet chamber 150, as best shown in FIG. 3A, an external receptacle/urinal 106 and a shared waste container 102 disposed within the internal toilet chamber 150. In one embodiment, essential portions of multi-user portable toilet 100 are often constructed out of light weight molded plastic, for easy transportation and cost effectiveness. As best shown in FIGS. 1A to 1D, instead of having four side panels to create a rectangular internal chamber, the multi-user portable toilet of the present invention 100 has five side panels, viz., door panel 130 at the front, right panel 132 and left panel 134, both adjacent to door panel 130, back panel 138, and urinal panel 108 that connects right panel 132, or left panel 134, to back panel 138. All five side panels leave a footprint, and connect to the top panel 136, in the shape of a pentagon.

[0027] FIGS. 2A through 2D are representative side views of an embodiment of the multi-user portable toilet 100 of the present invention. FIG. 2E is a representative top view of an embodiment of the multi-user portable toilet 100 of the present invention. As best shown in FIGS. 1B and 2E, the top panel 136 is a pentagon resembling a rectangle with one of its corners cut away, that corner replaced with urinal panel 108. As best shown in FIGS. 1C and 2A, a door 135 is installed on door panel 130 so users can enter and exit multi-user portable toilet 100. In one embodiment, a lock or other mechanical closures [not shown] can be installed on door 135 to enhance privacy. A slanting or sloped roof line 202 assists in preventing water pooling on the upper panel 136 during rain, etc.

[0028] FIG. 3A is a representative vertical cross-sectional view of an embodiment of the multi-user portable toilet 100 of the present invention showing the privacy compartment 150. In one embodiment, five side panels, viz.: door panel 130 at the front, right panel 132 and left panel 134, back panel 138, and urinal panel 108; and top panel 136, and optionally floor panel 101, create an enclosure i.e. privacy compartment 150. As best shown in FIG. 3A, privacy compartment 150 is an enclosed space which further equipped therein a commode or toilet 104 emptying into a waste containment chamber 102. In one alternative embodiment, water basin which also emptying into waste containment chamber 102, a cold/hot water tap, a soap dispenser could be included within privacy compartment 150. In another embodiment, commode with flushing and plumbing can be introduced to make the present invention 100 more pleasant. In yet another embodiment, lighting fixtures 140 can be installed within privacy compartment 150 for evening events. In yet another embodiment, electric fan, air-conditioning unit 133 and music loudspeakers [not shown] can be installed to further enhance the present invention 100. In one embodiment, speakers [not shown] can also be useful for providing audio instructions for use of the toilet 100, radio performance, emergency news broadcast, etc. optional equipment for the portable toilet 100 include auxiliary plumbing service hookups, hot water service, hot water heater, internal steam or chemical cleaning, holding tank for water, hot water and/or chemical cleaners.

[0029] FIG. 3B is a representative isometric view of an embodiment of the multi-user portable toilet 100 of the present invention showing assembly of external urinal panel 108. In one embodiment, the external urinal panel 108 further has an urinal 106 installed. The urinal 106 is also equipped with drainage means 114 such that it empties into the shared waste container 102 within privacy compartment 150 through drainage hole 112. In one embodiment, urinal panel 108 may be recessed, i.e., disposed within a cut-out or alcove in the external wall 109 surrounding the chamber to afford privacy to users. Further, the external wall 109 separating urinal panel 108 from privacy compartment 150 may include sound barrier or sound proofing layer 110 for further privacy between two simultaneous users of toilet 104, i.e., one within privacy compartment 150 and one using external urinal 106. It will be understood that sound proofing layers can also be installed, clad or lined on right panel 132, left panel 134 and/or back panel 138 to provide further privacy to users. In one embodiment, sound proofing layers increase acoustic separation between the inside and outside of privacy compartment 150. Examples of construction material of sound proofing layers or other sound reducing means 110 include "QUIET BARRIERS" Specialty Composite, which is an engineered acoustical composite of 1/2 inch decoupling foam, 1/8 inch high-mass sound-blocking barrier, and 3/4 inch noise absorbing foam with 3 mm reinforced mylar facing, as well as other active and passive noise disturbance and cancelling technologies, designed to provide significant air and structure borne noise reduction in a low-profile configuration.

[0030] FIG. 3C is a representative top isometric view of an embodiment of the multi-user portable toilet 100 of the present invention showing the contour design of top panel 136. In one embodiment, top panel 136 has vents 133 which are openings that improve air ventilation of privacy compartment 150. In one alternative embodiment, an electric fan [not shown] can be installed around vents 133 to further enhance ventilation. Moreover, one function of top edge panel 120 is

to divert falling rain away from door panel **130** and urinal panel **108**. External gutters can also be located to divert rain or other water fall to one side or another or to any intermediate, drainage point from the roof and top panel **136** as desired. Downspouts or scuppers can also be installed on the sides or corners of the portable toilet **100** of the present invention to collect and divert rain as desired. Directed drainage is also achieved by the contoured surface of top panel **136** which may have one or more ridges **122** to drain or divert moisture to right panel **132**, left panel **134** and/or back panel **138**. It is important to divert rain water away from the user. As for the urinal panel **108**, since it has urinal **106** that empties into waste containment chamber **102**, it is imperative to divert as much rain water away from urinal panel **108** as possible to avoid overflowing waste containment chamber **102**. In one embodiment, gutter or railing **120** can be installed at edge of top panel **136** at top of urinal panel **108**, acting as a dam to rain water.

[0031] FIG. **4** is a representative lateral, cut-away schematic view showing an embodiment of the portable toilet **100** of the present invention. In this embodiment, two users can multi-user portable toilet **100** simultaneously. The drainage means **114** connecting urinal **106** to waste containment chamber **102** within privacy compartment **150** and sound proofing layers **110** disposed along the side panels to provide additional privacy for simultaneous users.

[0032] FIG. **5** is a representative isometric view of an alternative embodiment of multi-user portable toilet **250** of the present invention where two external urinals **106** and **107** [not shown] are disposed upon the external shell, separated by a privacy protrusion **502**. In one alternative embodiments, urinals **106** are installed on both the urinal panel **108** and back panel **138** such that three users can use multi-user portable toilet **600** simultaneously.

[0033] FIG. **6A** is a representative top side view of multiple multi-user portable toilets **100** of the present invention in a row arrangement **200**. FIG. **6B** is a representative back side view of multiple multi-user portable toilets **100** of the present invention in a row arrangement **200**. FIG. **6C** is a representative upper back side view of multiple multi-user portable toilets **100** of the present invention in a row arrangement **200**. FIG. **6D** is a representative upper, isometric view showing a method of use of multiple multi-user portable toilets **100** of the present invention in a row arrangement **200**. In outdoor events, it is common to arrange multiple portable toilets together to create a temporary lavatory area. When a number of multi-user portable toilets **100** of the present invention are arranged in a row arrangement **200** as best shown in FIGS. **6A** to **6D**, left panel **134** of each multi-user portable toilet **100** acts as a screen, creating an external urinal area **210** within each multi-user portable toilet **100**. The external urinal area **210** provide even more privacy to urinal users.

[0034] FIGS. **7A** through **7C** are representative side, top isometric and top views, respectively, of multiple multi-user portable toilets **100** of the present invention in a stall arrangement **300**. In events held in places where outside walls **310** are available, multiple multi-user portable toilets **100** can be arranged in stall arrangement **300** as best shown in FIGS. **7A** to **7C**, creating a temporary stall **330** for the users of the external urinals **106**.

[0035] FIGS. **8A** and **8B** are representative top and upper isometric views, respectively, of multiple multi-user portable toilets **100** of the present invention in a chamber arrangement **400**. Multiple multi-user portable toilets **100** can be installed,

as best shown in FIGS. **8A**, to block on end of an event venue that has barricades **410** to create an instant outdoor lavatory **440** for urinal users.

[0036] FIGS. **9A** and **9B** are representative top and upper isometric views, respectively, of multiple multi-user portable toilets **100** of the present invention in a ring arrangement **500**. At event venues that no walls or barricades are available, multiple multi-user portable toilets **100** of the present invention can be installed in a ring arrangement **500**. Instantaneously creating a larger area for users to use urinals **106**.

[0037] For a better understanding of the invention reference is made to the following detailed description of the preferred embodiments thereof which should be taken in conjunction with the prior described drawings.

[0038] Unless defined otherwise, all technical and scientific terms used herein have the same meaning as commonly understood by one of ordinary skill in the art to which the present invention belongs. Although any methods and materials similar or equivalent to those described can be used in the practice or testing of the present invention, the preferred methods and materials are now described. All publications and patent documents referenced in the present invention are incorporated herein by reference.

[0039] While the principles of the invention have been made clear in illustrative embodiments, there will be immediately obvious to those skilled in the art many modifications of structure, arrangement, proportions, the elements, materials, and components used in the practice of the invention, and otherwise, which are particularly adapted to specific environments and operative requirements without departing from those principles. The appended claims are intended to cover and embrace any and all such modifications, with the limits only of the true purview, spirit and scope of the invention.

I claim:

1. An improved portable toilet for simultaneous, private use by two persons, the portable toilet comprising:
 - an internal compartment having a commode;
 - a waste containment chamber disposed below the commode for receiving waste;
 - an external shell enclosing the compartment and the waste containment chamber;
 - at least one urinal disposed externally upon the external shell; and
 - a drainage system connecting the external urinal to the waste containment chamber.
2. The portable toilet of claim **1**, wherein said external shell includes sound-proof insulation to increase acoustic separation between the internal compartment and the external urinal.
3. A portable toilet unit for accommodation of simultaneous use by one or more users, the portable toilet unit having a pentagonal footprint and comprising:
 - an outer shell portion formed integrally by a front door panel, two side panels extending perpendicularly from both sides of the front door panel, a back panel extending perpendicularly from one of the side panels and a urinal panel extending from the back panel at an angle, closing out the outer shell portion by connecting integrally to the opposite side panel;
 - a pentagonal top panel sealing the top of the outer shell portion;
 - an internal compartment created by the outer shell portion and the top panel, the internal compartment further hav-

- ing a commode disposed therein, and a waste containment chamber disposed below the commode; and at least one external urinal unit disposed upon the urinal panel, each of the external urinal unit further connected to and emptying into the waste containment chamber via a drainage system.
4. The portable toilet unit of claim 3 further comprising a floor portion separating the internal compartment from the ground.
5. The portable toilet unit of claim 3 wherein the front door panel further comprises a door, the door further comprises a mechanical closure.
6. The portable toilet unit of claim 3 wherein the top panel further comprises one or more openings for ventilation.
7. The portable toilet unit of claim 3 wherein the urinal panel further comprises a sound proofing layer.
8. The portable toilet unit of claim 3 wherein the front door panel, the two side panels and the back panel all further comprise a sound proofing layer.
9. The portable toilet unit of claim 7 wherein the sound proofing layer constructed of material including but not limited to QUIET BARRIERS specialty composite, other engineered acoustical composite, decoupling foam, high-mass sound-blocking barrier, noise absorbing foam, reinforced mylar facing designed to provide significant air and structure borne noise reduction in a low-profile configuration.
10. The portable toilet unit of claim 3 wherein the top panel has a contoured profile, including a plurality of slants and railings to divert rain away from the front door panel and the urinal panel.
11. The portable toilet unit of claim 3 further comprising a system for ventilation of the internal compartment of the portable toilet.
12. The portable toilet unit of claim 3 further comprising an additional external urinal unit disposed upon the back panel, the external urinal unit connected and emptying to the waste containment chamber via a drainage pipe.
13. The portable toilet unit of claim 12 further comprising an elongated screen panel extending outwardly at eye-level, from between the back panel and the urinal panel.
14. A temporary outdoor restroom area complex for events, the temporary outdoor restroom area complex comprising:
a plurality of multiple-users portable toilet units, each multiple-users portable unit further comprises an internal compartment further having a commode disposed therein, a waste containment chamber disposed below said commode for receiving waste, an external shell further having a front door panel, two side panels and a back panel, enclosing said internal compartment, at least one external urinal disposed upon the back panel, the urinal drainage means connecting said external urinal to said waste containment chamber, all multiple-users portable toilet units arranged in a partial circular configuration, leaving an entrance to the inner circular area, all multiple-users portable toilet units installed having each of its front door panel facing outwardly.

* * * * *