



US 20150261995A1

(19) **United States**

(12) **Patent Application Publication**
HUDGINS

(10) **Pub. No.: US 2015/0261995 A1**

(43) **Pub. Date: Sep. 17, 2015**

(54) **STYMIEING OF FACIAL RECOGNITION SYSTEMS**

(52) **U.S. Cl.**
CPC **G06K 9/00248** (2013.01); **G06K 9/00281** (2013.01)

(71) Applicant: **J. Stephen HUDGINS**, Blacksburg, VA (US)

(57) **ABSTRACT**

(72) Inventor: **J. Stephen HUDGINS**, Blacksburg, VA (US)

For surreptitiously stymieing a recognition of facial characteristics by a facial recognition system using a camera, a user wears an object in front of at least one eye, where the object includes a light displacer. The light displacer optically displaces light radially relative to the original light direction, but still parallel to the original light direction so that a view by the eye through the light displacer is not distorted. With the light displacer, there is an apparent position of the eye perceived by the camera which is shifted relative to other features of the face and relative to the actual position of the eye. Consequently, an image of the face obtained by the camera locates the eye at the apparent position which is substantially different from an image which would have been obtained with the actual position of the eye, so that the facial recognition system is stymied.

(21) Appl. No.: **14/025,229**

(22) Filed: **Sep. 12, 2013**

Publication Classification

(51) **Int. Cl.**
G06K 9/00 (2006.01)

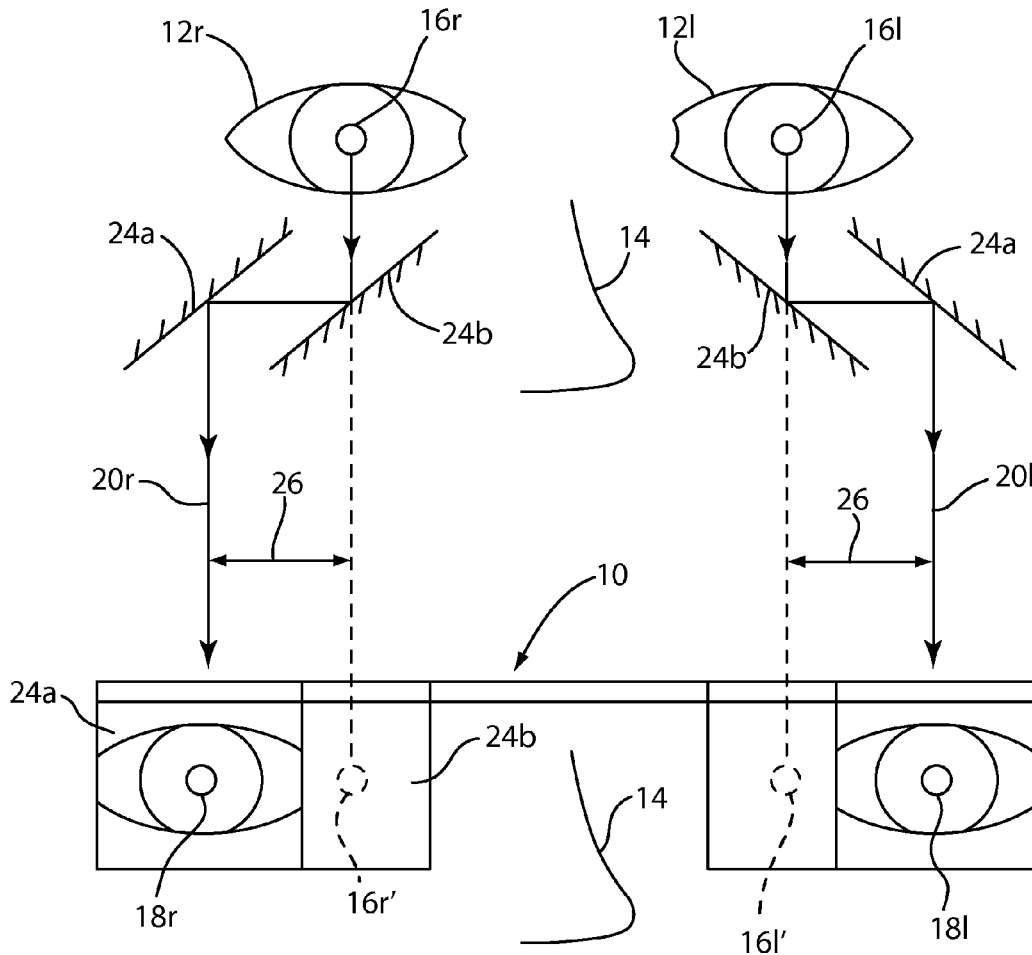

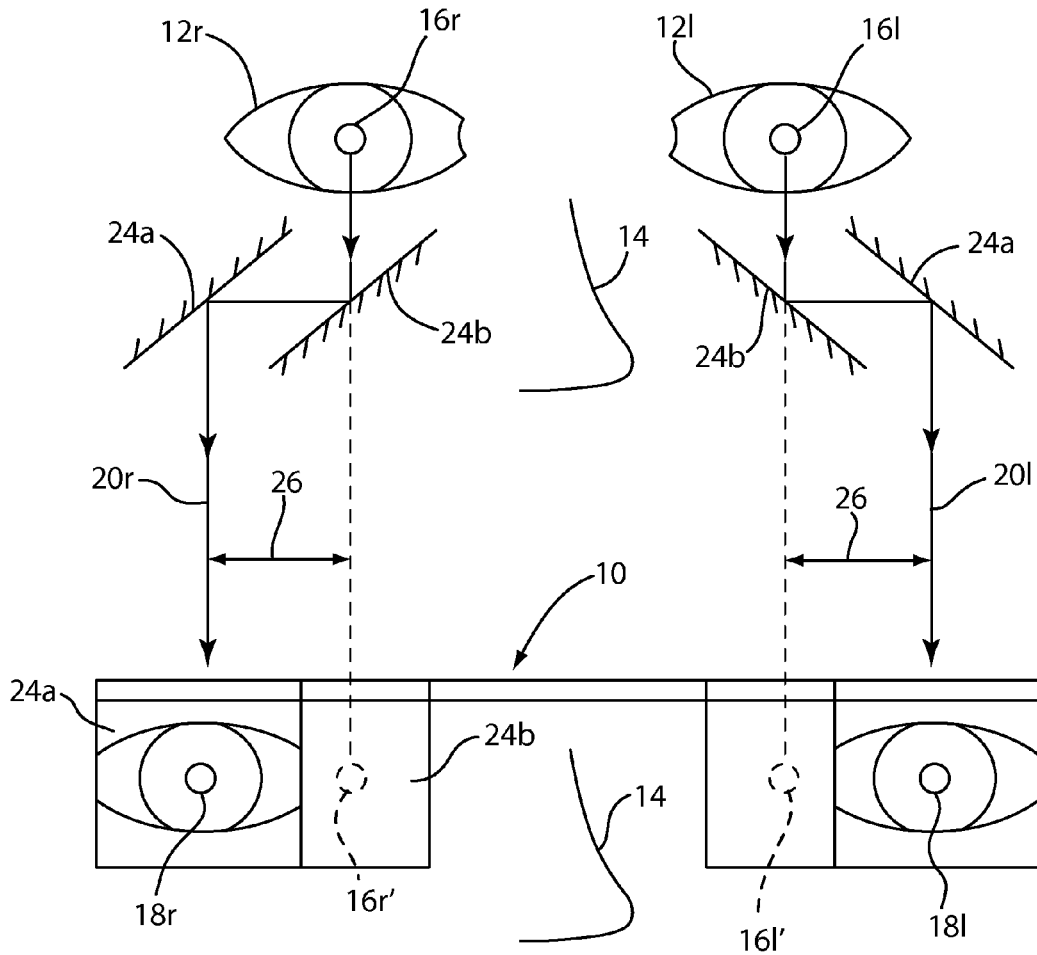

FIG. 1

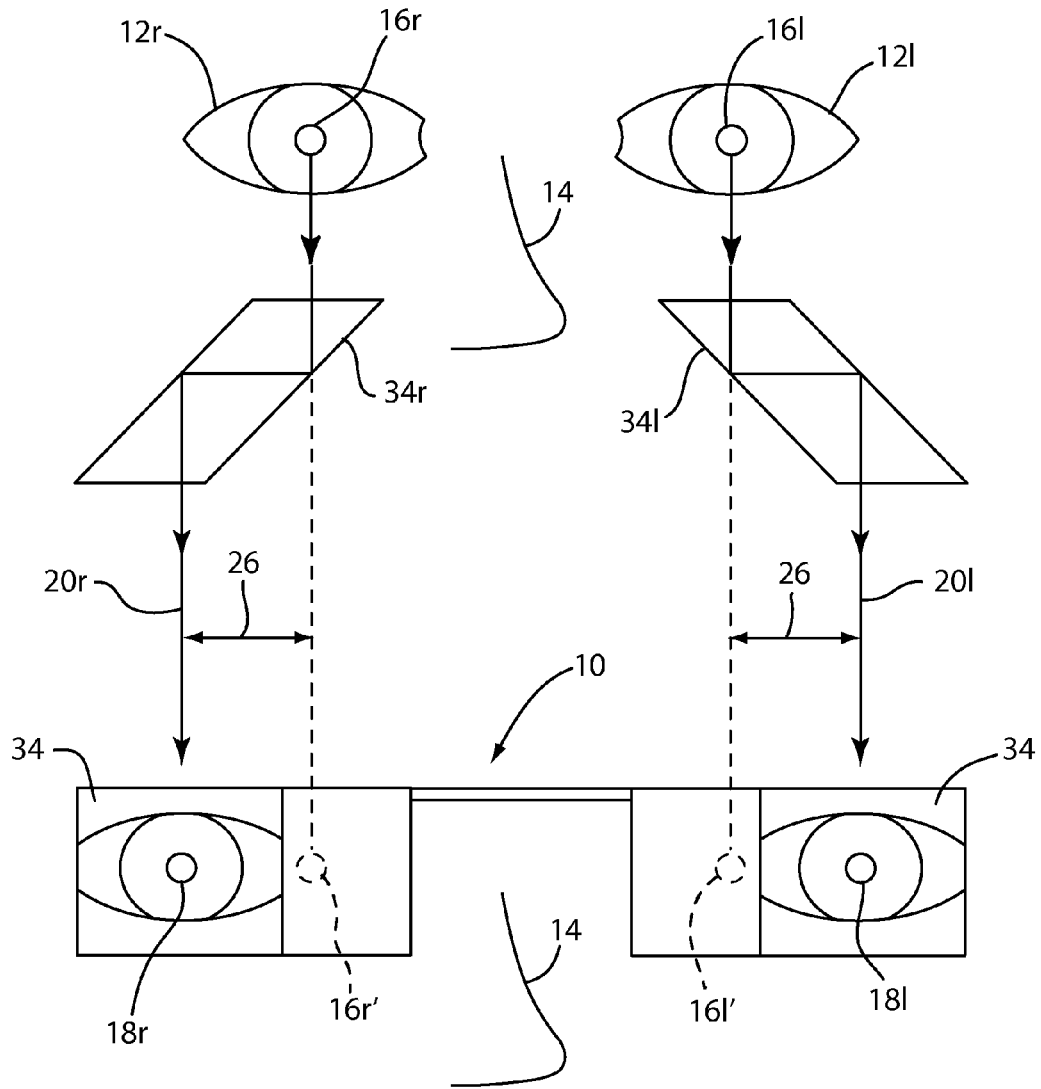

FIG. 2

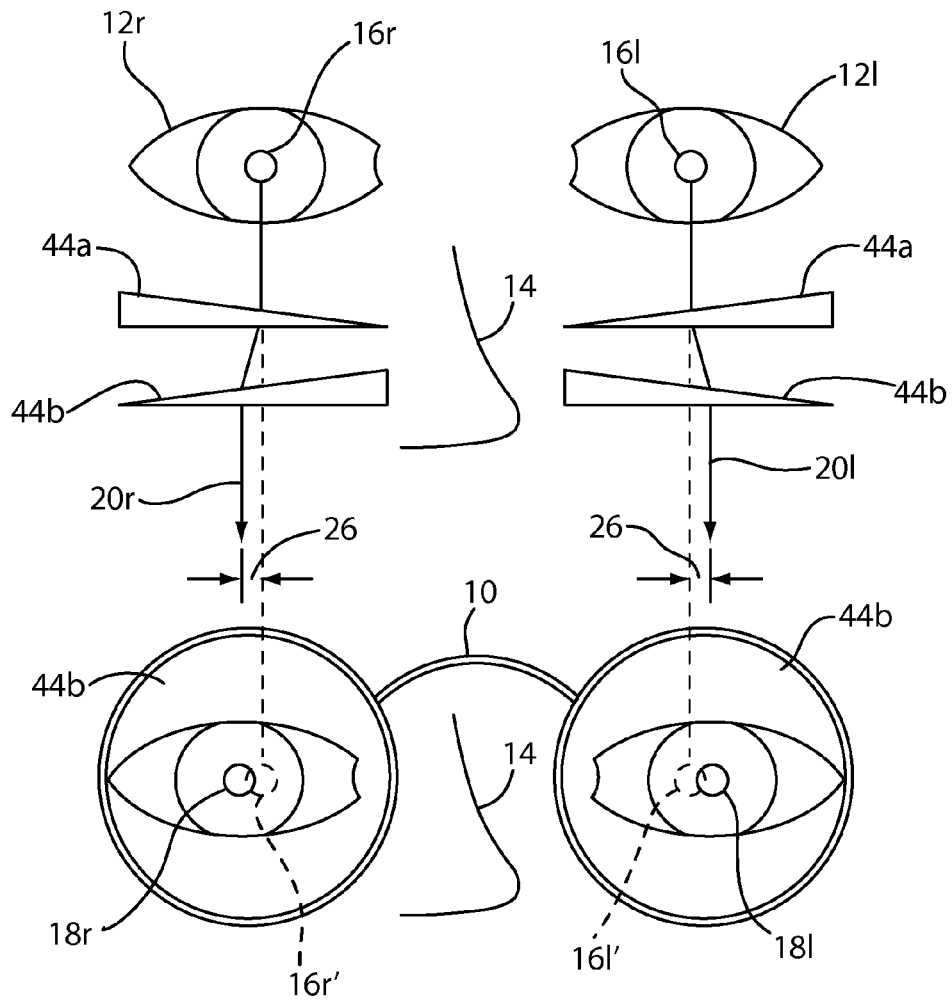

FIG. 3

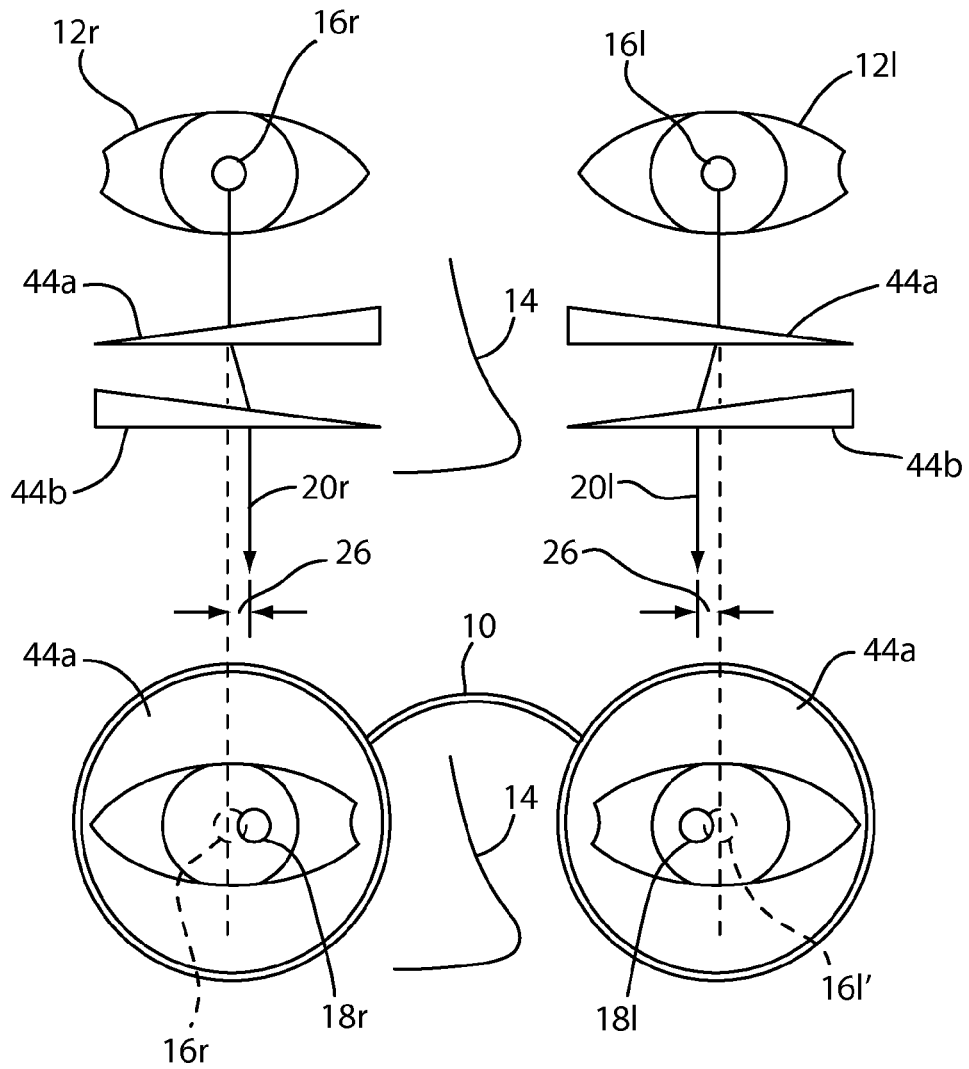

FIG. 4

STYMIEING OF FACIAL RECOGNITION SYSTEMS

BACKGROUND OF THE INVENTION

[0001] Facial recognition technology has, at the time of filing of this application, mainly been used in the United States by various national security agencies and police forces. While there has been some use of facial recognition technology in the private sector, these have been fairly limited. However, facial recognition technology has recently been incorporated in private security systems, such as those used for gambling casinos, and as a component in other software systems such as FACEBOOK, just to name a few of those applications. Fortunately, or unfortunately, depending on one's perspective, technology prognosticators have predicted an explosion in commercial products employing facial recognition technology in the fairly near future.

[0002] Facial recognition technology generally requires three functional components: a) an image of a face, which is taken from a digital camera or a video frame taken from a video camera, or any other image taken by a suitable camera and which can be digitized; b) facial recognition software to analyze the acquired image of the face; and c) a computer or other computational equipment needed to run the software and provide a database or a link to a database. Because all three of these components are becoming increasingly powerful, cheaper, and smaller quickly, it is believed that facial recognition is no longer going to be primarily limited to governmental security functions but instead will find itself incorporated in a wide array of other government and non-government activities and in particular commercial applications.

[0003] It will be appreciated that many facial recognition systems operate by obtaining an image of the person's face to be identified, and then by quantifying the location of various anatomical points or nodal points (landmarks) of the face, including the location(s) of the eye(s) as well as parts of and around the eye(s). The dimensions, locations and/or ratios of these points typically make up a "faceprint", which is then compared to a database of similar metrics (faceprints) to determine, where there is a match from the database, the identity of the face being scanned.

[0004] Thus, while the legitimate security functions of government and police agencies should not be circumvented, there are many individuals that would desire not to have their identity automatically and secretly determined in a non-security setting, such as inside a shopping mall. Fortunately, facial recognition technology is still not foolproof. Obviously, if one wears a mask over one's face, covers one's face with one's hand, or wears a fake nose and glasses, the recognition systems can be easily disrupted or potentially defeated. However, most people would not desire to walk around with a sock cap or the like pulled down over their face or with their hand or a magazine held up in front of their face for this obvious purpose, and in doing so would likely be recognized as doing so for the purpose of facial recognition system disruption.

[0005] Large dark sunglasses can also be worn in an attempt to disrupt a facial recognition system. However, the problem with large dark sunglasses is that they can be seen by others, and can be seen as an attempt to hide identity in locations such as a shopping mall where dark glasses are not typically used. Furthermore, dark sunglasses tend to reduce

light levels, and therefore reduce vision under lower light conditions such as at night or indoors.

[0006] Thus, it would be useful to have a method or device which would not be obvious to passersby or a facial recognition system as a facial recognition stymier or an attempt to defeat a facial recognition system, but which would alter ones appearance or facial characteristics as one passes by a facial recognition system surreptitiously.

BRIEF SUMMARY OF THE INVENTION

[0007] In accordance with the present invention, there is provided a method and apparatus for surreptitiously stymieing a recognition of facial characteristics of an individual by a facial recognition system, where the facial recognition system is designed to determine the locations of the eyes of a face of the individual as well as the location of other facial features of the individual when viewed by a camera of the facial recognition system. Stymieing of the facial recognition system is achieved by wearing of an object by the individual in front of the eyes of the individual, where the object includes a light displacer located adjacent at least one of the eyes of the individual but otherwise not covering other facial features. The light displacer optically displaces light passing there-through radially relative to the original light direction, but with the emerging radially displaced light being parallel to the original light direction. As a result, light reflected from the at least one of the eyes of the individual and passing through the light displacer to the camera is displaced radially but parallel relative to a direction of the reflected light received by the camera of the facial recognition system. With these effects, an individual's view by the at least one eye through the light displacer is not distorted. In addition, there is an apparent position of the at least one eye perceived by the camera looking through the light displacer which is shifted relative to other features of the face perceived by the camera by light not passing through the light displacer and relative to the actual position of the at least one eye. Consequently, an image of the face of the individual obtained by the camera of the facial recognition system locates the at least one eye at the apparent position which is substantially different from an image which would have been obtained with the actual position of the at least one eye, so that facial recognition by the facial recognition system is stymied.

[0008] In a preferred embodiment of the invention, a second light displacer is also located adjacent the other at least one of the eyes of the individual but otherwise not covering other facial features the face. As with the first-mentioned light displacer, the second light displacer also optically displaces light passing therethrough radially relative to the original light direction, but with the emerging radially displaced light being parallel to the original light direction. Consequently, an image of the face of the individual obtained by the camera of the facial recognition system locates both eyes at the apparent positions, which is substantially different from an image which would have been obtained with the actual position of both eyes, so that facial recognition by the facial recognition system is stymied. Where two light displacers are used, each can displace the light laterally or medially, or a combination of various directions including upwards and downwards.

[0009] In one preferred embodiment of the invention, the object worn is a pair of glasses with the light displacer or light displacers located where the lenses of the pair of glasses would typically be located. The light displacer is conveniently: two mirrors which together serve to radially but par-

allely displace light reflected thereby; a prism; or a pair of prisms which can be conventional prisms or Fresnel prisms or a combination of both. While the robustness of facial recognition systems vary, it is believed that displacing of the light by at least about 1 mm per eye, or 2 mm total, would be sufficient for satisfactory stymieing in most commercial situations.

[0010] It is an advantage of the present invention that an individual can change the appearance of their facial image as picked up by a camera of a facial recognition system without making the change apparent or noticeable to other passersby, and with this change thereby stymie recognition of their facial characteristics by the facial recognition system.

[0011] It is also an advantage of the present invention that the object which is worn to stymie the facial recognition system is a commonly worn object, so the use of the object to stymie would also not be apparent to passersby.

[0012] It is a further advantage of the present invention that the normal sight of the user is not affected.

[0013] It is still another advantage of the present invention that all features viewed by a facial recognition system through the light displacer will be displaced.

[0014] Other features and advantages of the present invention are stated in or apparent from detailed descriptions of presently preferred embodiments of the invention found hereinafter.

BRIEF DESCRIPTION OF THE SEVERAL VIEWS OF THE DRAWINGS

[0015] FIG. 1 is a front elevation view of a pair of glasses with the associated components shown schematically relative to the eyes of the user and is thus used for surreptitiously stymieing a facial recognition system in accordance with the present invention.

[0016] FIG. 2 is a front elevation view of an alternative embodiment of a pair of glasses with the associated components shown schematically as in FIG. 1.

[0017] FIG. 3 is a front elevation view of another alternative embodiment of a pair of glasses with the associated components shown schematically as in FIG. 1.

[0018] FIG. 4 is a front elevation view of still another alternative embodiment of a pair of glasses with the associated components shown schematically as in FIG. 1.

DETAILED DESCRIPTION OF THE INVENTION

[0019] With reference now to the drawings in which like numerals represent like elements throughout the views, there is schematically depicted in FIG. 1 a pair of glasses 10 having a typical frame which is worn by an individual or user, which user is schematically depicted by eyes 12/ and 12r and nose 14 only. It will be appreciated that glasses 10 are an exemplary embodiment of an object to be worn by the user for stymieing a facial recognition system in accordance with the present invention. While glasses 10 are considered the most likely object to be used for this purpose, other similar objects can also be used for the same effect which would be obvious to those of ordinary skill, such as a monocle, goggles, dark glasses (mostly for outside use) or a clip-on addition to normal glasses. But a simple pair of ordinary looking glasses is considered the preferred embodiment, since people wearing glasses are so ubiquitous, and so embodiments utilizing glasses 10 are described below to serve the purpose of surreptitiously stymieing a facial recognition system.

[0020] The schematic depiction in FIG. 1 shows eyes 12/ and 12r (above glasses 10) of the individual as they would be imaged by a facial recognition system when not looking through glasses 10. In particular, the facial recognition system image would determine the correct or actual separation of pupils 16/ and 16r (and/or other viewable features of or around the eyes, or the eyes as a whole, as desired, but for convenience reference is just made to the pupils hereafter) as viewed relative to one another and the locations of the eyes relative to nose 14 and any other selected anatomical points or features of the individual as typically utilized by the facial recognition system. Such an image would readily allow a proper identification of the individual by the facial recognition system if that individual was part of the facial recognition system database of individuals.

[0021] However, with glasses 10 appearing as normal glasses and being worn as usual by the user, the facial recognition system image would instead determine an incorrect (not actual) separation of pupils 16/ and 16r (and all other features viewed through glasses 10), as viewed relative to one another, and their locations relative to nose 14 and other selected features of the individual as typically utilized by the facial recognition system. As shown, the image of glasses 10 obtained by the facial recognition system would show pupils 16/ and 16r at apparent or perceived locations 18/ and 18r, which as evident are different from the actual pupil positions 16/ and 16r behind glasses 10 as shown in broken lines (that is, actual pupil positions 16/ and 16r are where pupils 16/ and 16r would have been imaged if not for the present invention and when regular glasses were worn). Such a distorted image would not readily allow a proper identification of the individual by the facial recognition system if that individual was part of the facial recognition system database of individuals, so that facial recognition of the individual would be stymied.

[0022] The present invention achieves this stymieing of the facial recognition system by shifting light beams 20/ and 20r reflected from eyes 16/ and 16r toward the camera or the like of the facial recognition system by use of light displacers 22/ and 22r. As the construction and effects of light displacers 22/ and 22r are the same, only light displacer 22r will be described in detail. Initially, it will be appreciated that light displacer 22r is depicted as it would be rotated 90° out of the page, in order to schematically show the effect light dispenser 22r has on light beam 20r. As thus shown, light displacer 22r includes two mirrors 24a and 24b which are mounted where lenses would normally be in glasses 10, and which mostly otherwise appear as lenses of glasses would appear since eye 12r of the user is mostly viewable.

[0023] As schematically shown in FIG. 1, mirrors 24 are carefully mounted or constructed relative to one another cause light beam 20r to be displaced radially relative to the original light beam 20r direction (in this case laterally or rightward) but otherwise parallel relative to the original light beam 20r direction and parallel to the direction of other light reflected from the face to the camera, such as from nose 14. As a result of this radial but parallel displacement, it will be important to appreciate that the user's view as seen through eye 12r and light displacer 22r is not distorted, so the user is not discomforted nor does the user have any perception problems relating to the user's normal vision. However, for a camera of the facial recognition system, there is a perceived pupil position 18r of pupil 16r of eye 12r viewed through glasses 10 which is different (radially displaced) from the actual pupil position 16r shown by broken lines (or an actual

position of eye **12_r** which is not shown by broken lines for convenience) which would be seen with normal lenses in glasses (or without glasses **10**). The perceived pupil position **18_r** is thus seen to be shifted rightward or laterally relative to the actual pupil position **16_r** (or actual right eye position), and this shifting distance is shown by distance arrow **26**. This shifting is relative to other features of the face perceived by the camera by reflected light not passing through light displacer **22_r** as well.

[0024] In operation, by use of light displacer **22_r**, an image of the face of the individual obtained by the camera of the facial recognition system locates eye **12_r** or pupil **16_r** at the apparent position identified by perceived pupil position **18_r**. This perceived pupil position **18_r** is substantially different from an image which would have been obtained with the actual pupil position **16_r** shown for pupil **16_r** of eye **12_r** without light displacer **22_r**, so that facial recognition by the facial recognition system is stymied by having improper or incorrect data. The lateral displacement is schematically shown by distance arrow **26**.

[0025] A similar displacement is achieved by light displacer **22_l** as noted above for light dispenser **22_r** and as shown. While one displacement using only one light displacer **22** would be possible and effective, in the preferred embodiment, paired light displacers **22_l** and **22_r** are used for double the displacement effect as shown and to maintain the same symmetry of the location of the eyes of the user. It will also be appreciated that due to having light beams going through light displacers **22** ending up parallel when the light beams leave light displacers **22**, the vision of the user is not distorted, and those viewing the user's face would not see the eyes or face as having been distorted since there is a wide variety of pupil spacings in the human population.

[0026] In the exemplary embodiment of the present invention in FIG. 1, the appearance of the back or non-mirrored side of mirror **24_b** in glasses **10** will be potentially appear a little abnormal to a viewer, since the back side would not be transparent. The amount of this abnormal appearance is exaggerated in FIG. 1 for convenience, and thus in an actual embodiment would be more modest. And while the mirrored side of mirror **24_a** would not be transparent either, the viewable portion would appear as if it were transparent since a viewer will simply see the eye (in mirror **24_a**) as expected behind the normal appearing glasses **10**, without any indication that a mirror is present and that the eye location has been displaced. It will also be appreciated that the size and effect of mirrors **24** have been exaggerated for an easier explanation of the effects achieved.

[0027] Depicted in FIG. 2 is a more preferred embodiment of the present invention which eliminates somewhat the problem of an appearance of a non-transparent portion being viewed in glasses **10**. In this embodiment, which is thus considered more practical, the same elements have been labeled with the same numbers as in FIG. 1. Thus, it will be seen that this FIG. 2 embodiment utilizes, instead of mirrors **24**, oblique rectangular prisms **34_l** and **34_r** which effect an internal reflection of light beams **20_l** and **20_r**. The effect of prisms **34** is thus the same as mirrors **24**, in that the light beams **20_l** and **20_r** are internally reflected therein and hence radially shifted as shown by distance arrow **26**; and thus there are perceived pupil positions **18_l** and **18_r** which are different from actual pupil positions **16_l** and **16_r**. In this embodiment, there would still be a small area adjacent the nose of glasses **10** where no reflected light is seen to pass through prisms **34**.

But as this area would seem to be transparent, it would appear to be simply a distorted part of what would be assumed by a viewer to be a lens of glasses **10**, and so it is submitted that it would raise little attention.

[0028] In another more preferred embodiment depicted in FIG. 3, the problem of an appearance of a non-transparent or distorted portion being seen next to the nose of glasses **10** is eliminated. In this embodiment, which is thus considered still more practical, the same elements have been labeled with the same numbers as in FIGS. 1 and 2. Thus, it will be seen that this FIG. 3 embodiment utilizes, instead of mirrors **24** or prisms **34**, paired right triangular prisms **44_a** and **44_b** which are shown spaced apart. Each prism **44_a** and **44_b** effects an equal but opposite deflection of light beams **20_l** and **20_r**, so that together radial but parallel displacement of light beams **20_l** and **20_r** is achieved as shown. The effect of prisms **44_a** and **44_b** is thus the same as in the previous embodiments, in that the light beams **20_l** and **20_r** are shifted as shown by distance arrow **26**; and thus there is a perceived pupil position **18_l** and **18_r** which is different from the actual pupil position **16_l** and **16_r**. Since prisms **44_a** and **44_b** would have a small thickness, there would effectively be no area adjacent the nose where no reflected light is seen to pass through, so that prisms **44_a** and **44_b** would appear to be a part of what would be assumed to be a normal lens of glasses **10** and thus they would raise no attention from a viewer.

[0029] In still another preferred embodiment depicted in FIG. 4, a setup similar to that of FIG. 3 is employed and utilized to the same basic effect and with the same elements labeled with the same numbers as in FIGS. 1, 2 and 3. However, it will be appreciated that in this embodiment, instead of shifting or displacing pupils **16** radially outward (laterally), pupils **16** are shifted radially inward (medially) as shown. This is achieved by reversing the positions of prisms **44_a** and **44_b** from that shown in FIG. 3.

[0030] As noted above, it is a critical feature of the present invention that the visual axis of the user is not disturbed, so that only small radial but ultimately parallel displacements of light beams are effected. It will thus be appreciated that while the displacements described above have all been radially rightward or leftward (lateral or medial), it is also within the scope of the present invention to effect upward and/or downward displacements, or any combination of the same or different (e.g., up and left for one eye, down and left for the other eye) radial displacements from the normal viewing axis. It is also considered that only one pupil (or eye) displacement might be sufficiently effective, but that two symmetrical displacements would be more effective and appear less artificial even upon closer scrutiny.

[0031] The various elements of the embodiments shown in the figures, and the size of displacement arrows **26** of light beams **20**, have been depicted for ease of illustration and are not necessarily to any scale. It will be appreciated that a minimum displacement of a light beam by at least about 1 mm per eye (but not in the same direction), or 2 mm total for only one eye, is considered to be sufficient for most commercial situations where the present invention would be used. However, a displacement of at least about 2 mm per eye or 4 mm total would be preferred for surer stymieing. And while greater displacements are possible, it is also considered that a single displacement of no more than about 5 mm per eye, or 1 cm total, would be more than a sufficient distance for satisfactory stymieing in most commercial situations.

[0032] Obviously, greater displacements are possible, and different embodiments would lend themselves to different displacements. For example, the embodiment of FIG. 1 where mirrors are used for the light displacers could achieve an eye displacement greater than a centimeter, though at some point beyond a centimeter of displacement the glasses 10 would not look much like a normal pair of glasses and that would not be desired. Similar large displacements could be achieved with the embodiment of FIG. 2 using oblique rectangular prisms, with the same limitation on size of displacement versus appearance. The embodiments of FIGS. 3-5 provide a more limited displacement relative to the other two embodiments. However, these embodiments are considered to be the more practical embodiments, or the more likely commercial embodiments, since the above noted minimum and maximum displacements are still easily achieved but with a more normal appearance of glasses 10.

[0033] Various light displacers have been disclosed above, but it will be appreciated that other light displacers with the same effects are also possible. For example, a Fresnel element (s) achieving a light displacement as described above could be used for a relatively thinner light displacer. Of course, Fresnel elements are seen to have small visible lines therein due to the grooves thereof, and so this appearance would be somewhat of a drawback to their use in a surreptitious system.

[0034] Thus, while the present invention has been described with respect to exemplary embodiments thereof, it will be understood by those of ordinary skill in the art that variations and modifications can be effected within the scope and spirit of the invention.

I claim:

1. A method for surreptitiously stymieing a recognition of facial characteristics of an individual by a facial recognition system designed to determine the locations of the eyes of a face of the individual as well as the location of other facial features of the individual when viewed by a camera of the facial recognition system, said method comprising the steps of:

wearing an object by the individual in front of the eyes of the individual, the object including a light displacer located adjacent at least one of the eyes of the individual but otherwise not covering other facial features the face;

optically displacing, with the light displacer, light passing therethrough radially relative to the original light direction but with the emerging radially displaced light being parallel to the original light direction,

whereby light reflected from the at least one of the eyes of the individual and passing through the light displacer to the camera is displaced radially but parallel relative to a direction of the reflected to the camera so that a) a view by the at least one eye through the light displacer is not distorted, and b) there is an apparent position of the at least one eye perceived by the camera looking through the light displacer which is shifted i) relative to other features of the face perceived by the camera by light not passing through the light displacer and ii) relative to the actual position of the at least one eye;

whereby an image of the face of the individual obtained by the camera of the facial recognition system locates the at least one eye at the apparent position which is substantially different from an image which would have been obtained with the actual position of the at least one eye, so that facial recognition by the facial recognition system is stymied.

2. A method for surreptitiously stymieing a recognition of facial characteristics of an individual by a facial recognition system as claimed in claim 1:

wherein said wearing step further includes the step of providing a second light displacer located adjacent the other at least one of the eyes of the individual but otherwise not covering other facial features the face; and

further including the steps of:

optically displacing, with the second light displacer, light passing therethrough radially relative to the original light direction but with the emerging radially displaced light being parallel to the original light direction,

whereby light reflected from the other at least one of the eyes of the individual and passing through the light displacer to the camera is displaced radially but parallel relative to a direction of the reflected to the camera so that a) a view by the other at least one eye through the second light displacer is not distorted, and b) there is an apparent position of the other at least one eye perceived by the camera looking through the second light displacer which is shifted i) relative to other features of the face perceived by light not passing through the second light displacer, and ii) relative to the actual position of the other at least one eye;

whereby an image of the face of the individual obtained by the camera of the facial recognition system locates the other at least one eye at the apparent position which is substantially different from an image which would have been obtained with the actual position of the other at least one eye, so that facial recognition by the facial recognition system is additionally stymied.

3. A method for surreptitiously stymieing a recognition of facial characteristics of an individual by a facial recognition system as claimed in claim 1, wherein the object worn is a pair of glasses with the light displacer located where one of the lenses of the pair of glasses would typically be located.

4. A method for surreptitiously stymieing a recognition of facial characteristics of an individual by a facial recognition system as claimed in claim 2, wherein the object worn is a pair of glasses with the first-mentioned and second light displacers are respectively located where the lenses of the pair of glasses would typically be located.

5. A method for surreptitiously stymieing a recognition of facial characteristics of an individual by a facial recognition system as claimed in claim 1, wherein the light displacer includes one of: two mirrors which together serve to radially but parallelly displace light reflected thereby, a prism, or a pair of prisms.

6. A method for surreptitiously stymieing a recognition of facial characteristics of an individual by a facial recognition system as claimed in claim 1, wherein said displacing step displaces the light by at least about 1 mm.

7. A method for surreptitiously stymieing a recognition of facial characteristics of an individual by a facial recognition system as claimed in claim 2, wherein the first-mentioned and second light displacers each displace the associated light laterally.

8. A method for surreptitiously stymieing a recognition of facial characteristics of an individual by a facial recognition system as claimed in claim 2, wherein the first-mentioned and second light displacers each displace the associated light medially.

9. A device worn by an individual to surreptitiously stymie a recognition of facial characteristics of the individual by a facial recognition system designed to determine the locations of the eyes of the individual as well as the location of other facial features of the individual when viewed by a camera of the facial recognition system, said device comprising:

an object which is worn by the individual, said object including

a light displacer located adjacent at least one of the eyes of the individual but otherwise leaving a majority of the face viewable thereabout, said light displacer optically displacing light passing therethrough radially relative to an original light direction but with the emerging radially displaced light being parallel to the original light direction, whereby light reflected from the at least one of the eyes of the individual and passing through said light displacer to the camera is displaced radially but parallel relative to a direction of the reflected light to the camera so that a) a view by the at least one eye through said light displacer is not distorted, and b) there is an apparent position of the at least one eye perceived by the camera looking through said light displacer which is shifted i) relative to other features of the face perceived by the camera by light not passing through the light displacer and ii) relative to the actual position of the at least one eye;

whereby an image of the face of the individual obtained by the camera of the facial recognition system locates the at least one eye at the apparent position which is substantially different from an image which would have been obtained with the actual position of the at least one eye, so that the facial recognition by the facial recognition system is stymied.

10. A device worn by an individual to disrupt recognition as claimed in claim **9**, wherein said object is a pair of glasses, and wherein said light displacer is located where one of the lenses of the pair of glasses would typically be located.

11. A device worn by an individual to disrupt recognition as claimed in claim **9**, wherein said light displacer includes two mirrors which together serve to radially but parallelly displace light reflected thereby.

12. A device worn by an individual to disrupt recognition as claimed in claim **9**, wherein said light displacer is a prism.

13. A device worn by an individual to disrupt recognition as claimed in claim **9**, wherein said light displacer is a pair of prisms.

14. A device worn by an individual to disrupt recognition as claimed in claim **9**, wherein there are a left and a right said light displacers, said left and right light displacers being located where the left and right lenses of the pair of glasses would be expected to be found.

15. A device worn by an individual to disrupt recognition as claimed in claim **9**, wherein said light displacer displaces the light by at least about 1 mm.

16. A pair of glasses which is worn by an individual to surreptitiously stymie a recognition of facial characteristics of the individual by a facial recognition system designed to determine the location of the eyes of the individual relative as well as the location of other facial features of the individual when viewed by a camera of the facial recognition system, said pair of glasses comprising:

a glasses frame;

a first lens mounted in said frame to be adjacent a first eye of the individual, said first lens displacing light passing therethrough radially relative to an original light direction but with the emerging radially displaced light being parallel to the original light direction, whereby light reflected from the first eye of the individual and passing through said first lens to the camera is displaced radially but parallel relative to a direction of the reflected light to the camera so that

a) a view by the first eye through the first lens is not distorted, and

b) there is an apparent position of the first eye perceived by the camera looking through said first lens which is shifted i) relative to other viewed features of the face perceived by the camera by light not passing through the light displacer and ii) relative to the actual position of the first eye; and

a second lens mounted in said frame to be adjacent a second eye of the individual;

whereby an image of the face of the individual obtained by the camera of the facial recognition system locates the first eye at the apparent position which is thus substantially different from an image which would have been obtained with the actual position of the first eye, so that facial recognition by the facial recognition system is stymied.

17. A pair of glasses which is worn by an individual to disrupt recognition as claimed in claim **16**, wherein said light displacer is a prism or a pair of prisms.

18. A pair of glasses which is worn by an individual to disrupt recognition as claimed in claim **16**, wherein there are a left and a right said light displacers, said left and right light displacers being located where the left and right lenses of the pair of glasses would be expected to be found.

19. A pair of glasses which is worn by an individual to disrupt recognition as claimed in claim **18**, wherein said left and right light displacers each displace the associated light one of laterally or medially.

20. A pair of glasses which is worn by an individual to disrupt recognition as claimed in claim **16**, wherein said first lens displaces the light by at least about 1 mm.

* * * * *